

**ROLLON**<sup>®</sup>  
Linear Evolution

**Modline**

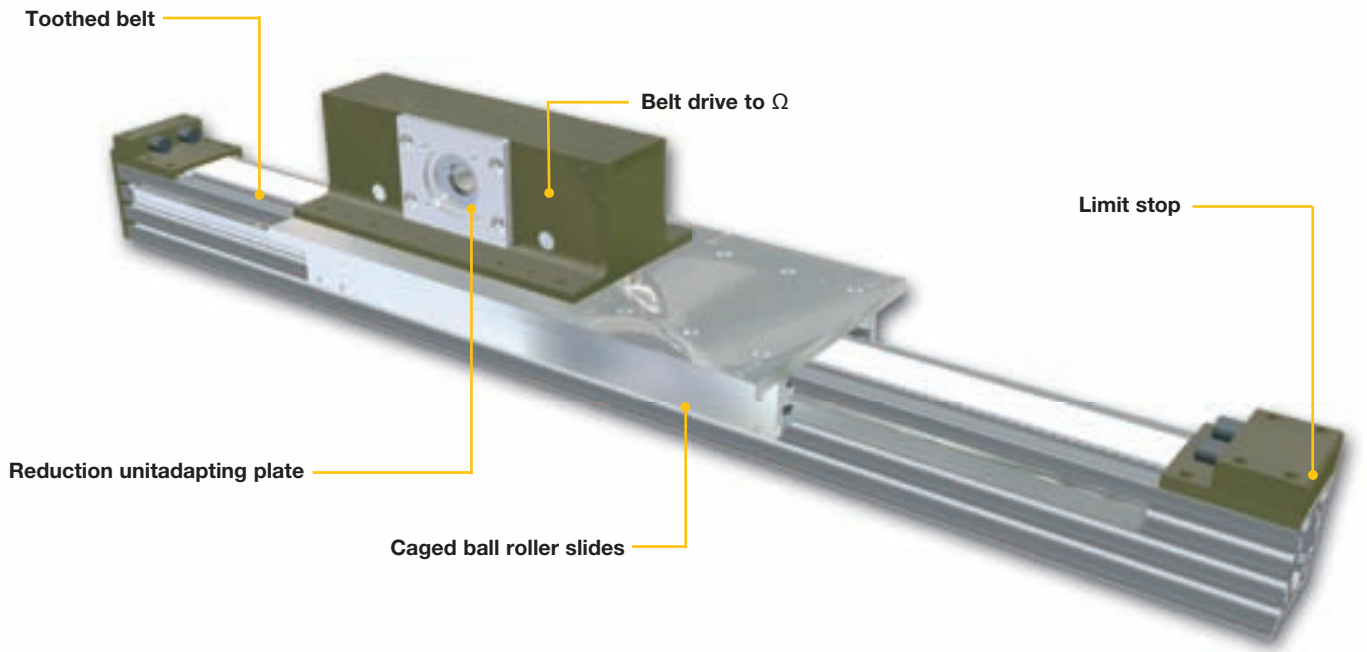

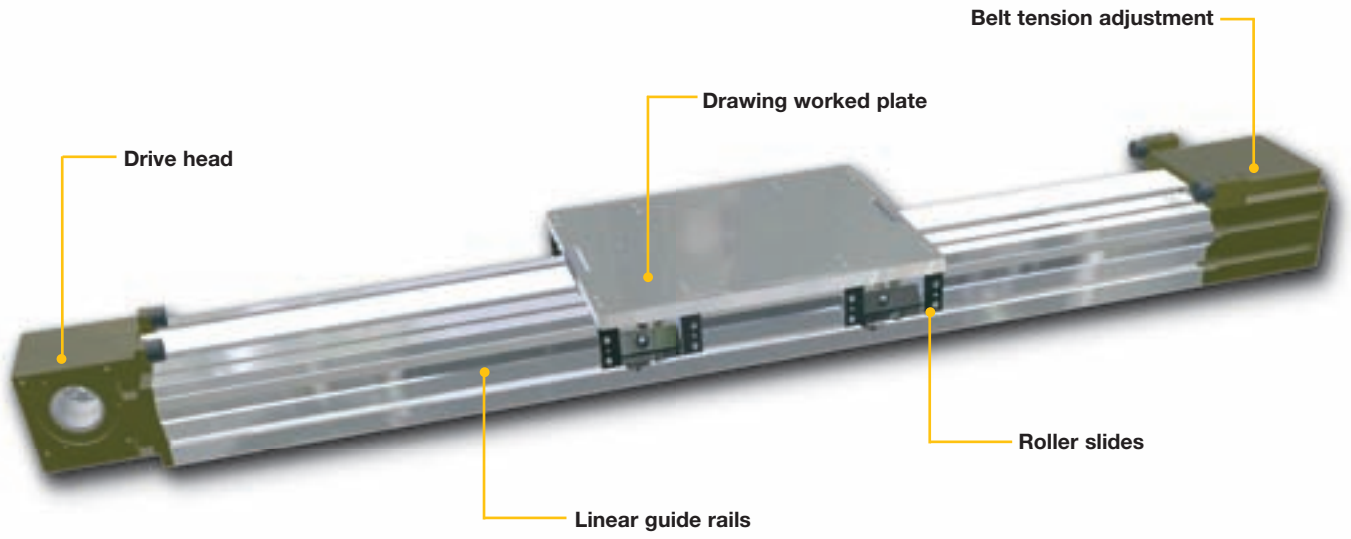



**Modline** linear modules are ready-to-use linear guide systems with high accuracy, speeds and load performances.

Our experience in the fields of the automotive plants, painting, plate working, manufacturing machines and palletization systems has allowed us to widen our product range with the most advanced technical solutions.

Our products stand out for their:

- high quality and **competitive performances** (profiles up to 12m)
- **without play transmissions** achieved by high torque couplings
- **beams** with transversal stiffening ribs and preset for threads on profile ends
- **accurate scaling** and consequent reduced maintenance
- **fast** and accurate **belt** or without play screw drives
- the most **complete range** of accessories

**The Modline linear module strong points are:**

- A complete series of linear units to build up 3 or more axis cartesian robots
- Linear modules with linear guides suitable for parallel assembling
- Choice between strong steel linear guides with rollers or accurate caged ball roller slides and guides
- Choice between mobile carriage or fixed carriage and mobile profile
- Wide and complete solutions for control systems; programmable cards on request
- On request: assembling of E-chain cable carriers, reduction units, stiffening angle bars
- Drawing worked carriage plates
- Accessories and compatibility for pinion/rack drive unit integrated assembling

## INTRODUCTION



Construction Features	ML-2
Assembly and lubrication specifications	ML-3
Introduction – operation and control unit - tightening specifications	ML-4
Standard assembly solutions	ML-5
Sizing template	ML-6
Sizing request form	ML-7
Preliminary selection table (1-2-3 axes)	ML-8
Special applications with standard modules	ML-9
Assembly positions and order code setting	ML-10
Order Code	ML-11
Profile specifications	ML-12

## M MODULES WITH BELT DRIVE



MCR 65 with rollers	ML-16
MCH 65 with caged ball roller slides	ML-17
MCR 80 with rollers	ML-18
MCH 80 with caged ball roller slides	ML-19
MCR 105 with rollers	ML-20
MCH 105 with caged ball roller slides	ML-21
MCLL 105 with twin guide and caged ball roller slides	ML-22

## MODULES WITH SCREW DRIVE



MVR 80 - MTR 80 trapezoidal screw and rollers	ML-23
MVR 105 - MTR 105 with ball / trapezoidal screw and rollers	ML-24
MVS 105 - MVH 105 with ball / trapezoidal screw and rollers	ML-25
MVHH 105 with ball screw and caged ball roller slides	ML-26
TVH 180 with ball screw and caged ball roller slides	ML-27
TVS 170 with ball screw and caged ball roller slides	ML-28
TVS 220 with ball screw and caged ball roller slides	ML-29

## T MODULES WITH BELT DRIVE



TCG 100 with shaped rollers	ML-30
TCH 100 - TCS 100 with caged ball roller slides	ML-31
TCR 180 - TCG 180 with rollers	ML-32
TCH 180 - TCS 180 with caged ball roller slides	ML-33
TCRQ 170 with rollers	ML-34
TCH 170 - TCS 170 with caged ball roller slides	ML-35
TCRQ 200 with rollers	ML-36
TCH 200 - TCS 200 with caged ball roller slides	ML-37
TCRQ 220 with rollers	ML-38
TCH 220 - TCS 220 with caged ball roller slides	ML-39
TCRQ 280 - TCRP 280 with rollers	ML-40
TCH 280 - TCS 280 with caged ball roller slides	ML-41
TCRP 360 with rollers	ML-42
TCH 360 - TCS 360 with caged ball roller slides	ML-43
TECRQ - TECH 170 (EASY) with roller or recirculating ball slides	ML-44
TECRR 180 - TECH 180 (EASY) with trapezoidal guides and roller slides	ML-45

## Z MODULES WITH OMEGA BELT DRIVE



ZCG 60 with shaped rollers	ML-46
ZCL 60 with caged ball roller slides	ML-47
ZCG 90 with shaped rollers	ML-48
ZCRR 90 with rollers	ML-49
ZCL 90 with caged ball roller slides	ML-50

This document replaces all previous editions.  
 Due to the constant progress of our research we reserve the right to modify drawings or features without notice.  
 No part of this catalogue may be reproduced without written permission of the copyright owner.  
 All rights reserved.  
 This catalogue has been accurately checked before publishing.  
 However, we disclaim all responsibility in case of errors and omissions.

<b>ZCY 180</b> with guide profile and shaped rollers	ML-51
<b>ZCRQ 100</b> with rollers	ML-52
<b>ZCL 100</b> with caged ball roller slides	ML-53
<b>ZCRQ 170 - ZCERQ 170</b> with rollers	ML-54
<b>ZCL 170 - ZCEL 170</b> with caged ball roller slides	ML-55
<b>ZCRQ 220 - ZCERQ 220</b> with rollers	ML-56
<b>ZCL 220 - ZCEL 220</b> with caged ball roller slides	ML-57
<b>ZMCPLL 105 - ZMCLL 105</b> with pneumatic counter balance	ML-58
<b>ZMCH 105</b> with pneumatic counter balance	ML-59



**K MODULES WITH BELT DRIVE**

<b>KCH 100 - 150 - 200</b> with recirculating ball slides	ML-60
---	-------

**ACCESSORIES AND APPLICATIONS**



Drive Pulley Bores for Shrink Discs	ML-61
Adapter Flanges	ML-62
Connecting shafts for parallel modules	ML-63
Spare rollers - mounting brackets	ML-64
Accessories and screws	ML-65
Front insertable nuts and plates	ML-66
Threaded nuts and plates	ML-67
Alignment nuts	ML-68
Micro-switch supports - cams and cam-holders for micro-switches	ML-69
Special Options	ML-70
Special applications	ML-71
Anti-drop system - lock-pin device	ML-72
Index	ML-74

# Construction Features

---

## Beams

Obtained from Rollon extruded and anodised aluminium alloy profiles. Material features: Al Mg Si 0.5 hardened and tempered, F25 quality, Rm 245 N/mm<sup>2</sup>, tolerance as per EN 755-9 and EN 12020-2. Profiles have been specially designed to achieve high stiffness and long lengths (up to 12 m), in order to obtain solid, lightweight structures, suitable for the construction of linear transfer machines.

## Plates

Obtained from aluminium alloy rolled sections, tensile strength Rm 290 N/mm<sup>2</sup>, HB 77, high performance. On request we perform machining work on all standard plates (D code) and according to detailed customer drawings.

## V-shaped guide rails

In hardened and ground high carbon steel (min. hardness 58 HRC). (Anti-oxidation coating upon request).

## Guide rails for caged ball roller slides

S version: high performance, with cage, primary producers. L version: high dynamics, medium loads. H version: standard performance and limited dynamics.

## Roller slides

Body in aluminium alloy G AL SI 5 hardened and tempered according to UNI 3600 or Alloy 6082, rollers with double rows of angular contact ball bearings, backlash-free, long life lubrication: Ø 30, Ø 40, Ø 52, Ø 62 mm rollers. Adjustable tolerance between rollers and guide rails. Complete with new felt scrapers.

## Toothed drive and driven pulleys

In C40 steel with coupling toothing on the polyurethane belt, backlash-free, with anti-oxidation treatment. Equipped with large, watertight bearings, capable of withstanding high work performance, due to the use of the multicarriage with durable, alternating backlash-free movements.

## Toothed belts

In durable polyurethane, fitted with high-resistance reinforced with high tensile strength steel cords, which prevent the belt from lengthening over time. They are grease, oil and gasoline-proof and can work at temperatures from - 30° up to +80°. The belt is fastened to the plate by means of a hooked support. The belt can be serviced without disassembling the equipment on the plate (standard versions).

## Shrink-discs, shafts and pulleys

All models shown in the catalogue work with the standard conical shrink-disc drive system to lock the driving shaft and the driven shaft if present. Gearbox or shaft adapting plates are supplied upon request, as per drawing.

## Bumper Stops

Important: the rubber stop pads provided with standard linear models are suitable and regarded as static limit switches. For special needs, such as stops if the drive breaks, please specify loads, dynamics, details and discuss the use of specific parts, accessories and devices (reinforced plates and attachments - shock absorbers, anti-drop devices, etc.) with our technical dept.

## Anodizing

We supply all linear modules equipped with: natural, anodised aluminium alloy profiles (min. 11µ), driving heads, driven heads, carriages (MC series), counter plates, in dark bronze anodizing (min. 11µ).

## Anti-oxidation parts and coatings

Modules are also available with anti-oxidation coating. Materials and coatings are selected according to the environment of use (food industry, marine environment, etc.).



## Main features of the roller translation system

The translation system consists of a plate to which two roller slides with concentric pins and two with eccentric pins are fixed. The eccentric pins are suitable for adjusting backlash between the roller slide and the sliding track. Check that the angular position of the rollers is such that they can support the max. working load (page ML-10).

Guide rails and roller slides are particularly suitable for use in dusty and aggressive environments.

**Important:** during adjustment, overloading is easily achieved: this may result in premature wear.

**NB: always keep friction low. If friction is high, loosen and repeat the adjustment.**

## Main features of the caged ball roller slides translation system

The sliding system guarantees high performance in terms of precision and load resistance, reduced maintenance and stiffness thanks to the connecting slots of the profile.

**All guide rails are directly fixed onto the profile surface, appropriately machined to guarantee geometric and dimensional tolerances, paying attention to the parallelism between them. In large modules, any profile flatness or parallelism errors are corrected by means of the appropriate machining procedures. Please inform our technical dept. of any specific application requirements.**

**When mounting the linear axes in parallel, it is necessary to not only verify the parallelism between the linear units themselves, but also the coplanarity of the surfaces of the heads so that the maximum error does not exceed 0.3 mm per meter between the parallel modules and within  $\pm 0.03$  mm compared to the parallelism.**

## Lubrication

### Roller slides and caged ball roller slides

Roller slides are provided with a permanent lubrication system which, if properly used, eliminates the need for any further maintenance, also considering the average life of any handling device. As for screw modules, the caged ball or V screw requires periodical lubrication.

For applications on plants with a high number of daily cycles, or with a significant build-up of impurities, please check the need for lubrication, seals and additional tanks with our technical dept. Do not use solvents to clean rollers or roller slides, as you could unintentionally remove the grease lubricating coat applied to the rolling elements during assembly.

Use lithium soap based mineral grease according to DIN 51825 - K3N. Read the instruction manual



*Complete central lubrication system. Grease cartridge upon request.*

### Guide rails

If properly assembled, guide rails do not require any lubrication, which would attract impurities and have negative consequences. Should there be any surface defects on the guide rails and/or on the rolling parts, such as pitting or erosion, this might be due to an excessive load. In this case, all worn parts must be replaced and the load geometry and alignment checked.

## **Introduction - operation and control unit**

---

These units can be equipped with gearboxes, servomotors, mechanical limit switches, proximity switches and various accessories, such as energy chains, interface plates, fixing supports.

Our technical dept. is at your complete disposal for any scaling requirements and the choice of linear actuator suitable to achieve the required performance levels. We can draw on our experience to help our customers in their choice of linear unit and the following parts:

gearboxes: worm screw, planetary, bevel;

motors: stepper, brushless, DC, asynchronous.

### **Application examples:**

glue dispensing units

paint or resin distribution units

load/unload of manufacturing machines

pick and place systems

control and sensing instrument handling

drilling PCB boards

cartesian robots with 2, 3 or more axes

## **Tightening specifications**

---

During set-up, make sure all parts are locked with the appropriate screws and with the right tightening torques.



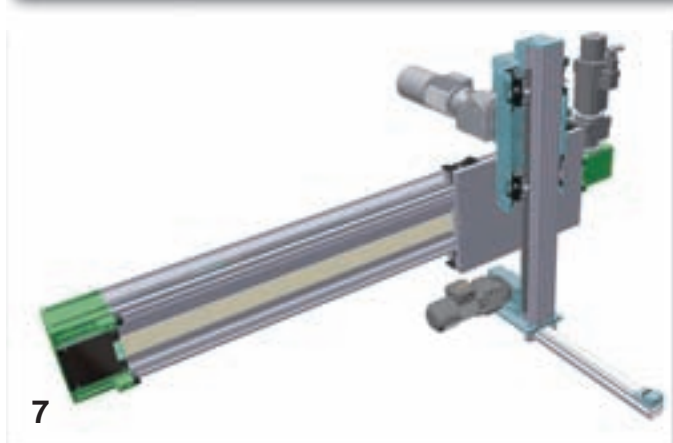
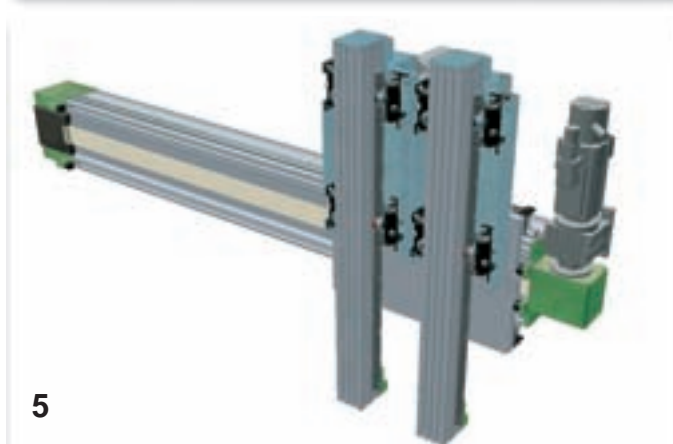
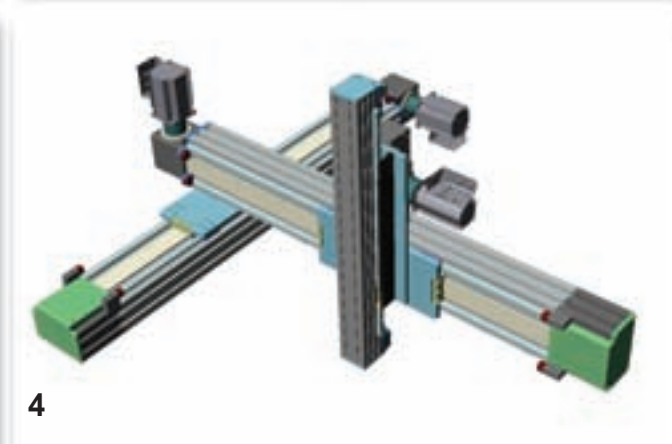
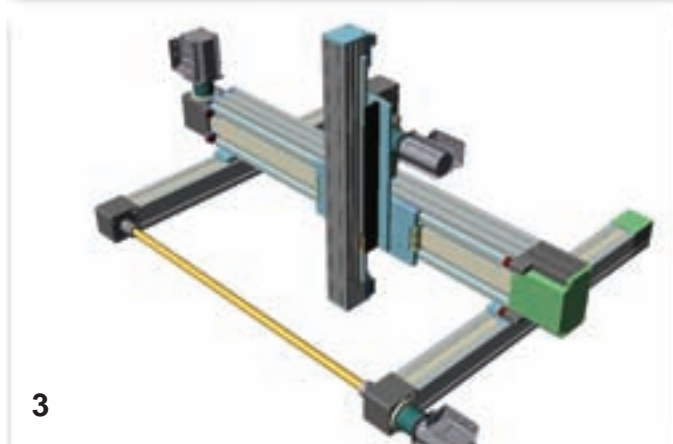
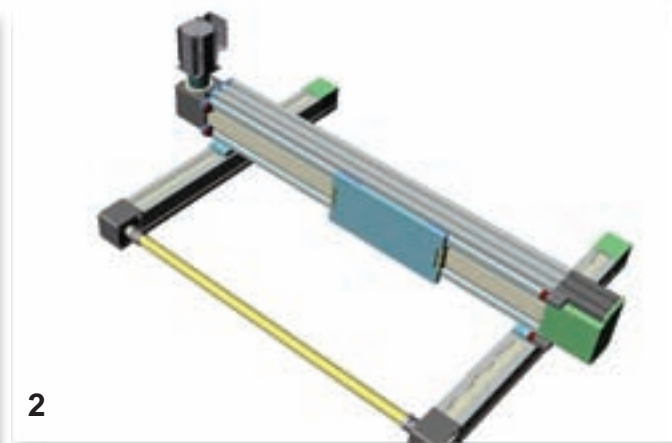
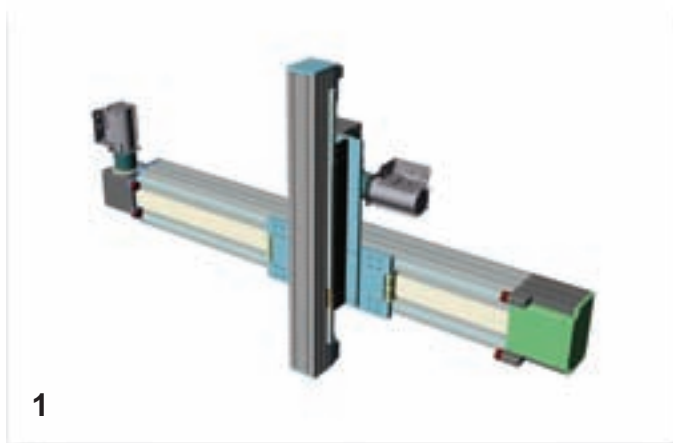

M  
L

# Sizing template

Our **Technical Support dept.** is available to check sizing calculations. Please fill in the form with all the necessary data and send it to our technical dept., which will suggest the most suitable size according to the forces applied and precision required.

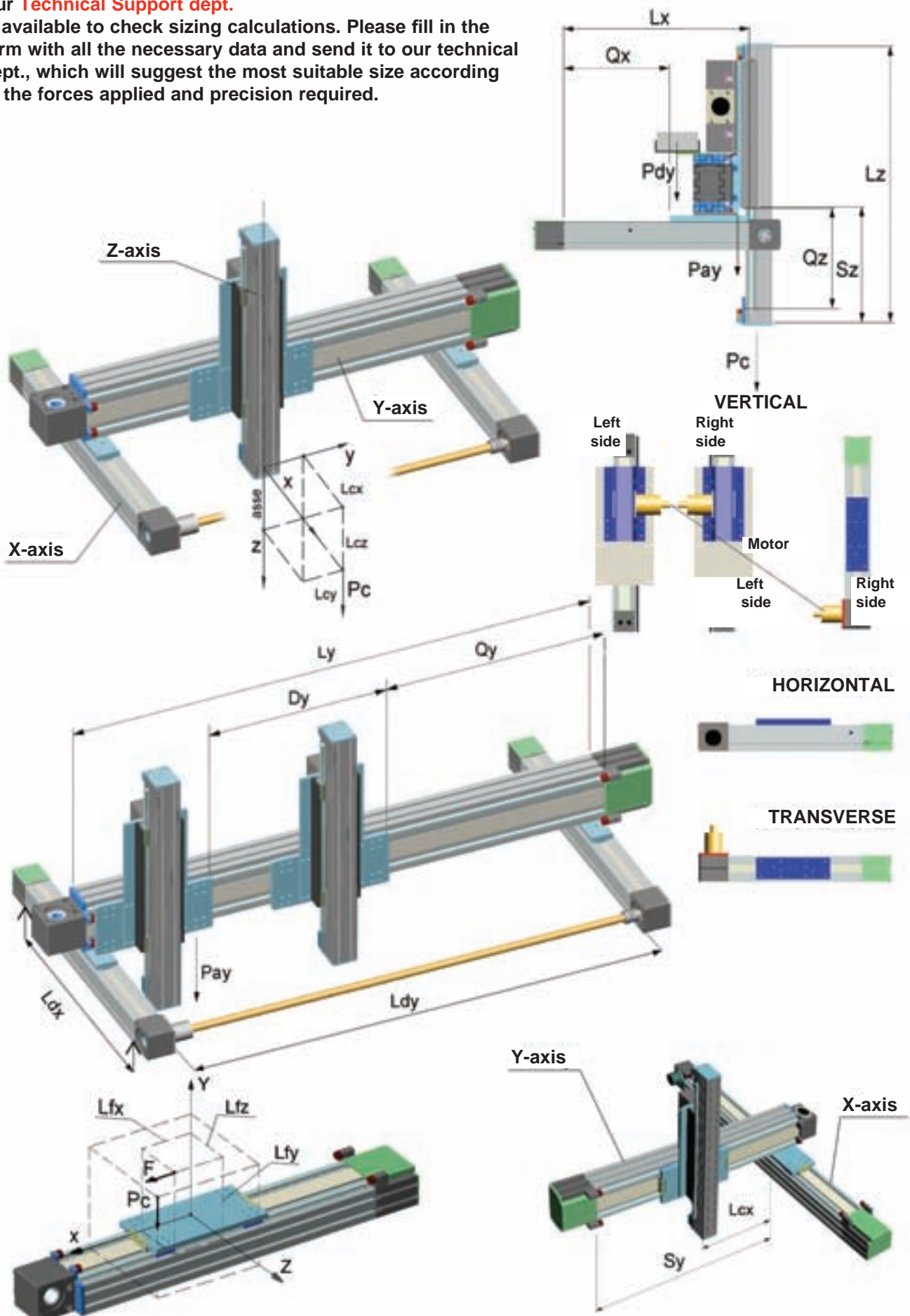

# Sizing request form

For a proper definition of the linear units, fill in the scaling request form and send it to the Technical Support Department.

Date: .....Request n°.....

Filled in by.....

Company.....

Address.....

Phone .....Fax.....

E-mail .....

## Sizing template

required data    optional data

## MODLINE linear modules

ASSEMBLY SOLUTIONS (see page ML-5) no. \_\_\_\_\_

- Total length
- Total working load including EOAT (add Z axis for Y and X axes)
- Equipment weight on carriage (gearbox, cylinder, OPTIONAL)
- Weight distributed on the beam (energy chain)
- Profile supports
- Max. projection (any cantilever, the largest)
- Max. span
- Offset load's centre of gravity (X-axis)
- Offset load's centre of gravity (Y-axis)
- Offset load's centre of gravity (Z-axis)
- Any additional force
- Offset additional force (X-axis)
- Offset additional force (Y-axis)
- Offset additional force (Z-axis)
- Possible distance between the carriages
- Transmission performance
- Assembly: vertical= 90° - slope = 30°, 45°, 60° - horizontal
- Stroke
- Speed
- Acceleration
- Cycle time
- Positioning accuracy
- Repeatability
- Work environment (temperature and cleanliness)
- Daily working cycles
- Minimum service life requested

	Z-axis	Y-axis	X-axis		
Lz	<input type="text"/>	Ly	<input type="text"/>	Lx	<input type="text"/> [mm]
Pc	<input type="text"/>	Py	<input type="text"/>	Px	<input type="text"/> [kg]
Paz	<input type="text"/>	Pay	<input type="text"/>	Pax	<input type="text"/> [kg]
Pdz	<input type="text"/>	Pdy	<input type="text"/>	Pdx	<input type="text"/> [kg/m]
		n°		n°	
Sz	<input type="text"/>	Sy	<input type="text"/>	Sx	<input type="text"/> [mm]
		Ldy		Ldx	<input type="text"/> [mm]
Lcx	<input type="text"/>				<input type="text"/> [mm]
Lcy	<input type="text"/>				<input type="text"/> [mm]
Lcz	<input type="text"/>				<input type="text"/> [mm]
F		F		F	<input type="text"/> [N] +/-
Lfx	<input type="text"/>				<input type="text"/> [mm]
Lfy	<input type="text"/>				<input type="text"/> [mm]
Lfz	<input type="text"/>				<input type="text"/> [mm]
Dz	<input type="text"/>	Dy	<input type="text"/>	Dx	<input type="text"/> [mm]
η	<input type="text"/>				
α=	<input type="text"/>				
Qz	<input type="text"/>	Qy	<input type="text"/>	Qx	<input type="text"/>
Vz	<input type="text"/>	Vy	<input type="text"/>	Vx	<input type="text"/> [m/s]
Az	<input type="text"/>	Ay	<input type="text"/>	Ax	<input type="text"/> [m/s <sup>2</sup> ]
Tz	<input type="text"/>	Ty	<input type="text"/>	Tx	<input type="text"/> [s]
+/-	<input type="text"/>				<input type="text"/> [mm]
+/-	<input type="text"/>				<input type="text"/> [mm]
n°	<input type="text"/>	<input type="text"/>	<input type="text"/>	<input type="text"/>	<input type="text"/> [Km]

**Working cycle**

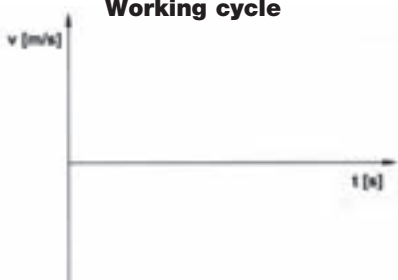

**Example working cycle**

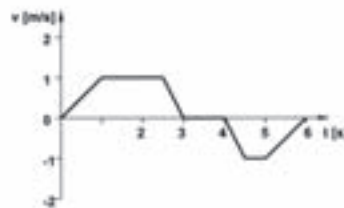

**Notes:**.....  
 .....  
 .....  
 .....



## Special applications with standard modules

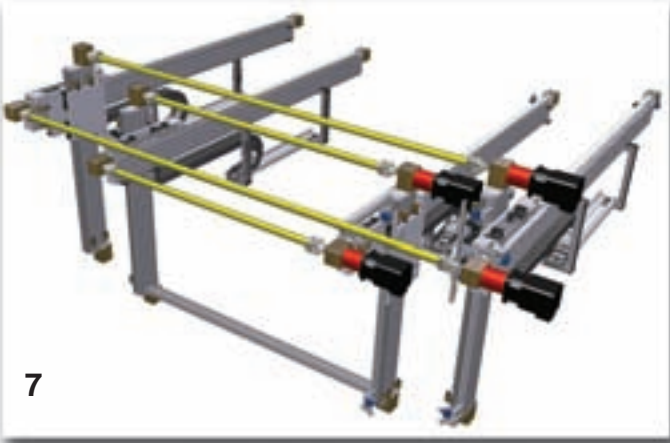
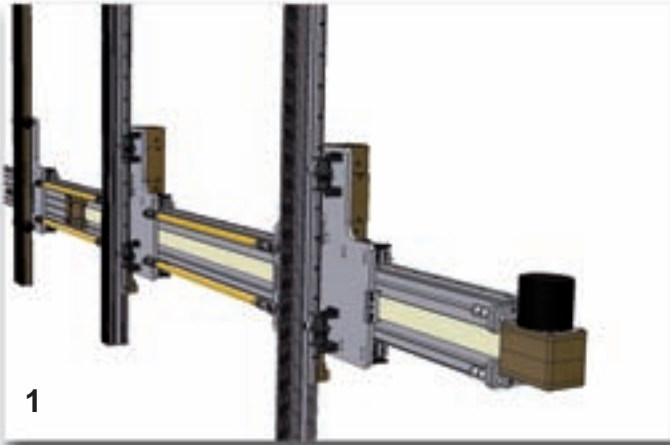

- 1 Multi-gripper handling system with belt drive
- 2 Panel handling system, construction industry
- 3 Tool handling system in the iron and steel industry
- 4 Pick and place system for storage battery production plant
- 5 Pick and place system for packaging plant
- 6 Pick and place system for breadboards
- 7 Pick and place system for production plant

# Assembly positions and load direction

For rollers profiles.

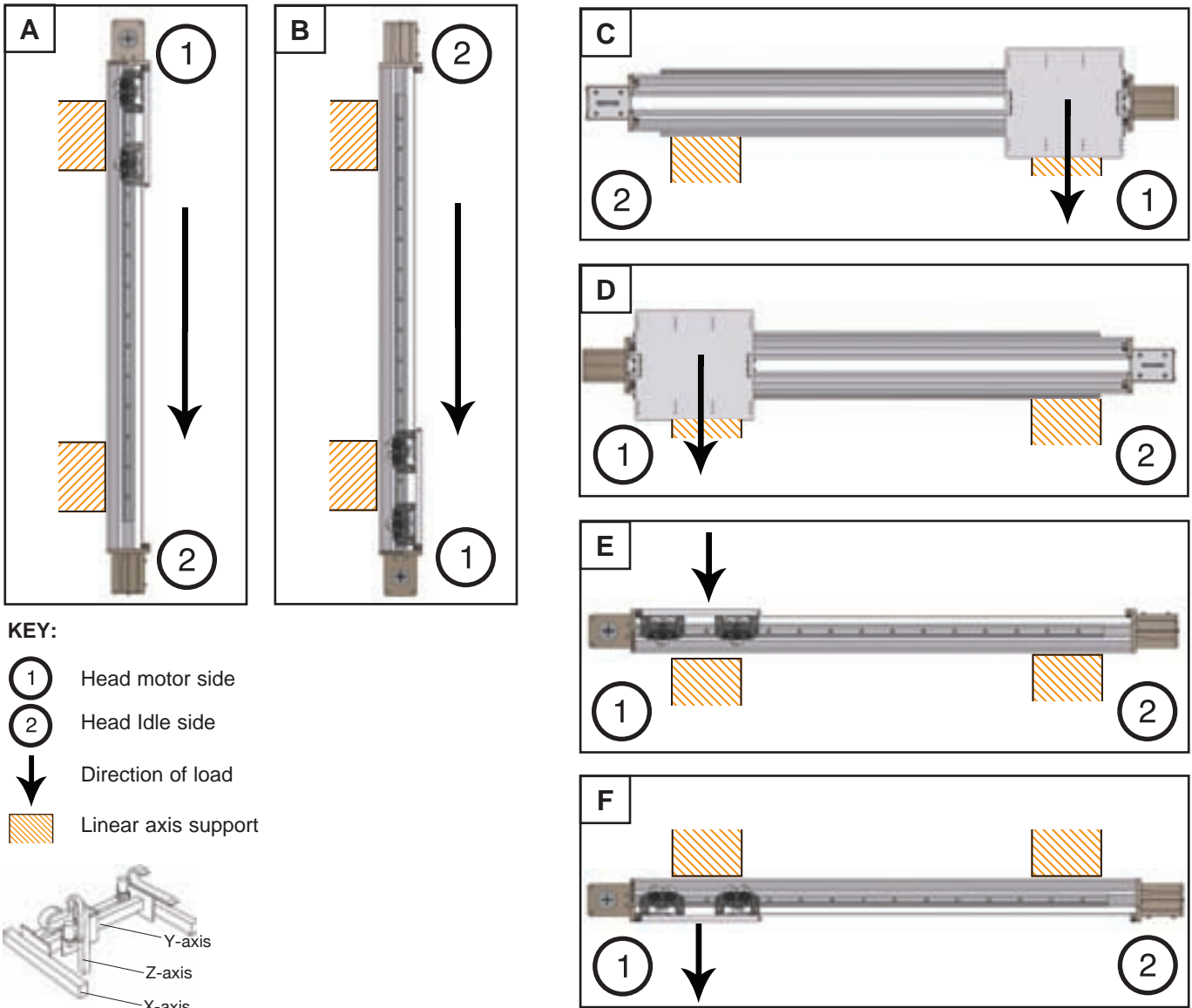

## Simplified code setting of the module

<b>EXAMPLE</b>		<b>T</b>	<b>C</b>	<b>S</b>	<b>M</b>	<b>280</b>	<b>mm/mm/</b>	<b>...</b>
<b>SERIES</b>	<b>K=</b> light <b>M=</b> compact closed section <b>T=</b> heavy <b>Z=</b> vertical omega belt							
<b>HANDLING</b>	<b>C=</b> belt <b>CE=</b> large belt <b>V=</b> ball screw <b>T=</b> trapezoidal screw <b>N=</b> idle							
<b>SLIDE</b>	<b>RR / RQ / RP =</b> guide rails for roller sl. Ø30 / Ø40 / Ø52 o Ø62 <b>S=</b> guide rails for caged balls roller slides <b>H=</b> guide rails for caged ball roller slides <b>G=</b> guide rails for cylindrical shaped rollers <b>Y=</b> guide rails for polyamide shaped rollers							
<b>MACHINING PROFILE</b>	<b>M=</b> profile with machined guide plane and rack plane							
<b>PROFILE SIZE</b>								
<b>STROKE / Length</b>	"mm" = X-axis / Y-axis / Z-axis							
<b>ACCESSORY CODES</b>	Various accessory codes							





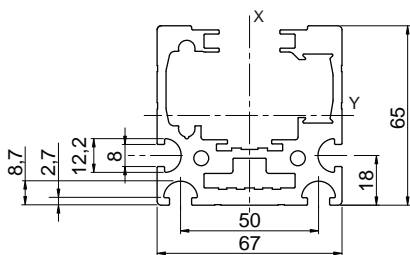

Profile	M 65x67	
Weight per metre	4.5	[kg/m]
Max. length	9	[m]
Moment of inertia I <sub>y</sub>	683,900	[mm <sup>4</sup> ]
Moment of inertia I <sub>x</sub>	796,750	[mm <sup>4</sup> ]
Module	MCR/L/H 65	

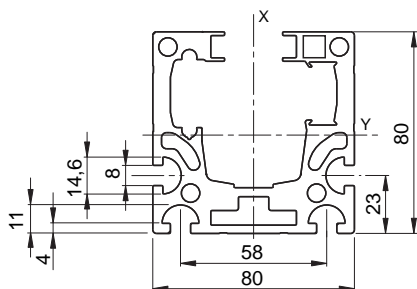

Profile	M 80x80	
Weight per metre	6.3	[kg/m]
Max. length	8	[m]
Moment of inertia I <sub>y</sub>	1,430,000	[mm <sup>4</sup> ]
Moment of inertia I <sub>x</sub>	1,780,000	[mm <sup>4</sup> ]
Module	MCR/S/H 80 - MVR/S/T 80	

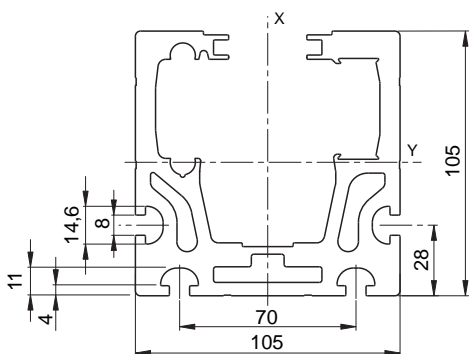

Profile	M 105x105	
Weight per metre	11	[kg/m]
Max. length	7,6	[m]
Moment of inertia I <sub>y</sub>	4,466,000	[mm <sup>4</sup> ]
Moment of inertia I <sub>x</sub>	5,660,000	[mm <sup>4</sup> ]
Module	MCR/S/H - MVR/S/T 105	

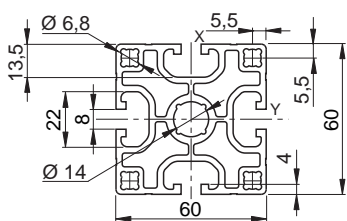

Profile (60x60)	F01-1	
Weight per metre	3.6	[kg/m]
Max. length	6	[m]
Moment of inertia I <sub>y</sub>	466,600	[mm <sup>4</sup> ]
Moment of inertia I <sub>x</sub>	466,600	[mm <sup>4</sup> ]
Module	ZCG/L 60	

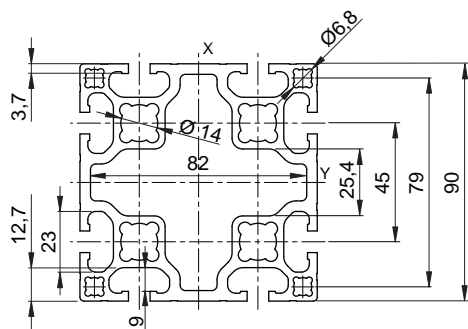

Profile (90x90)	E01-4	
Weight per metre	6	[kg/m]
Max. length	6	[m]
Moment of inertia I <sub>y</sub>	2,027,000	[mm <sup>4</sup> ]
Moment of inertia I <sub>x</sub>	2,027,000	[mm <sup>4</sup> ]
Module	ZCG - ZCL - ZCRR 90	

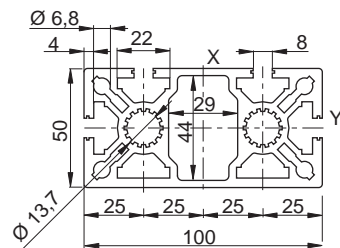
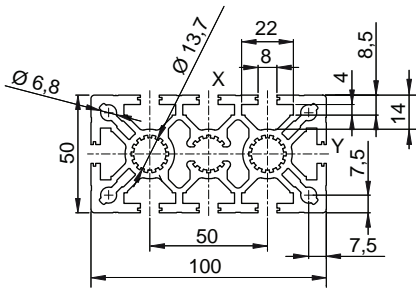

Profile (50x100)	MA 1-2	MA 1-4	
Weight per metre	5.3	5.2	[kg/m]
Max. length	6	6	[m]
Moment of inertia I <sub>y</sub>	502,800	543,100	[mm <sup>4</sup> ]
Moment of inertia I <sub>x</sub>	1,986,600	2,036,700	[mm <sup>4</sup> ]
Module	ZCR/L 100H	TCG/TCS/H 100	

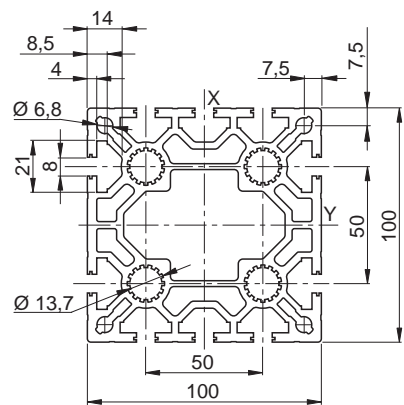

Profile (100x100)	MA 1-5	
Weight per metre	9.5	[kg/m]
Max. length	6	[m]
Moment of inertia I <sub>y</sub>	3,650,000	[mm <sup>4</sup> ]
Moment of inertia I <sub>x</sub>	3,800,000	[mm <sup>4</sup> ]
Module	ZCR/L 100	

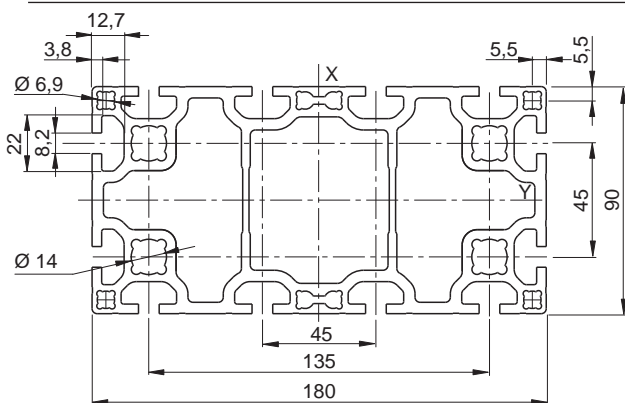

Profile (90x180)	E01-5	
Weight per metre	12.4	[kg/m]
Max. length	8	[m]
Moment of inertia I <sub>y</sub>	4,420,000	[mm <sup>4</sup> ]
Moment of inertia I <sub>x</sub>	15,180,000	[mm <sup>4</sup> ]
Module	TCR/G/S/H/ 180	

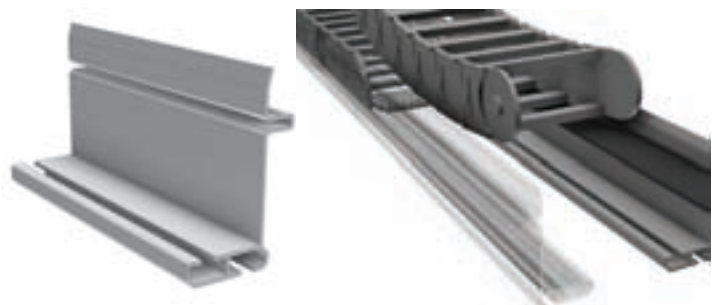
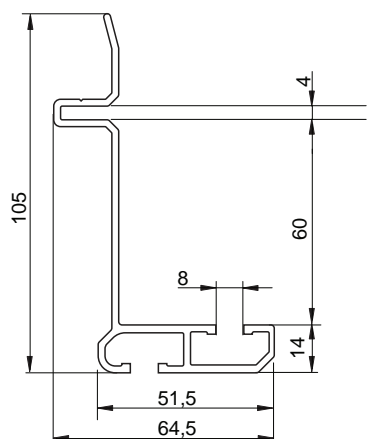

7400568 energy chain support profile		
Weight	1.5	kg/m
Available length	6	m

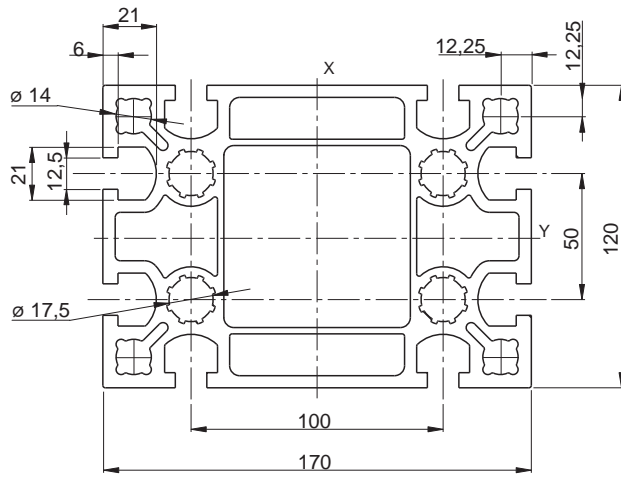

**Statyca (120x170)**

Weight per metre	17	[kg/m]
Max. length	12	[m]
Moment of inertia Iy	10,200,000	[mm <sup>4</sup> ]
Moment of inertia Ix	20,360,000	[mm <sup>4</sup> ]
Module	TCR/S/H 170 - ZCR/L 170	

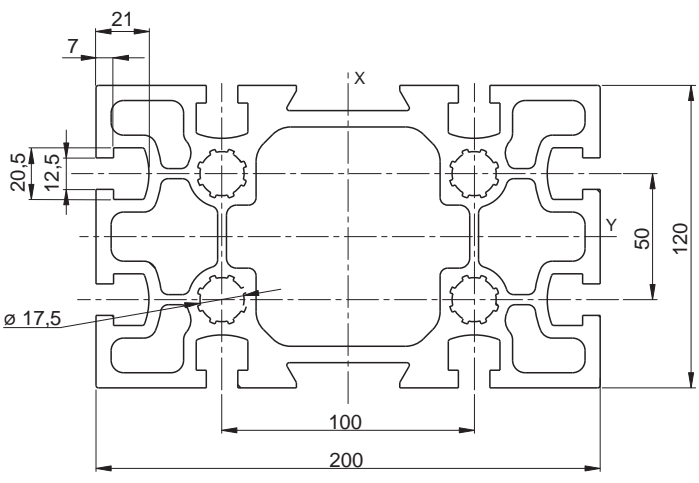

**Valyda (120x200)**

Weight per metre	21	[kg/m]
Max. length	12	[m]
Moment of inertia Iy	12,980,000	[mm <sup>4</sup> ]
Moment of inertia Ix	32,980,000	[mm <sup>4</sup> ]
Module	TCR/S/H 200	
Anodised up to	9	[m]

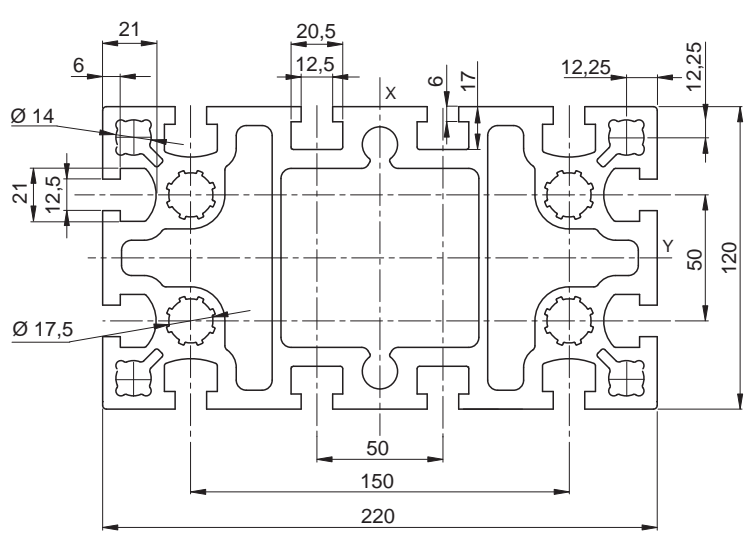

**Logyca (120x220)**

Weight per metre	25	[kg/m]
Max. length	12	[m]
Moment of inertia Iy	15,650,000	[mm <sup>4</sup> ]
Moment of inertia Ix	46,550,000	[mm <sup>4</sup> ]
Module	TCR/S/H 220-ZCR/L/ 220	
Anodised up to	9	[m]

M  
L

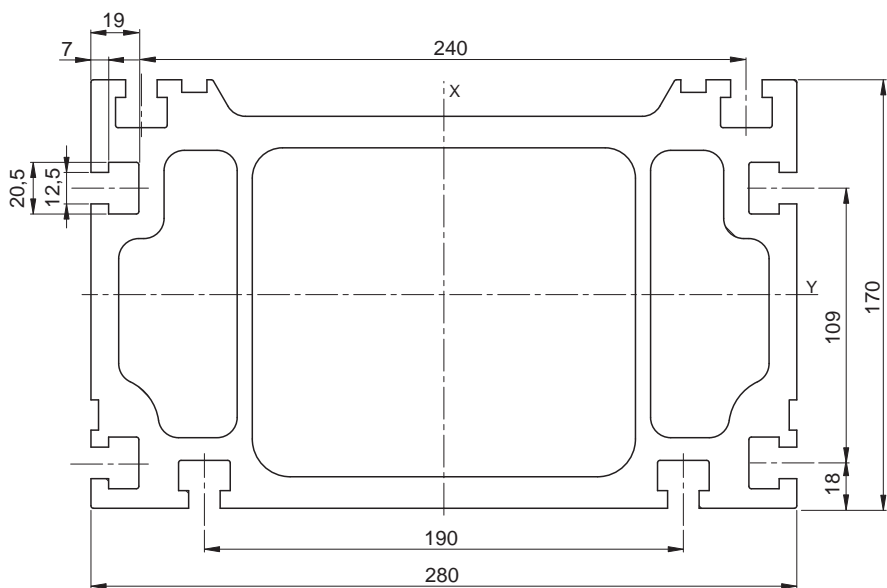

### Pratyca (170x280)

Weight per metre	40	[kg/m]
Max. length	12	[m]
Moment of inertia Iy	50,288,000	[mm <sup>4</sup> ]
Moment of inertia Ix	134,103,000	[mm <sup>4</sup> ]
Module	TCR/RP/S/H 280	
Usually not anodised		

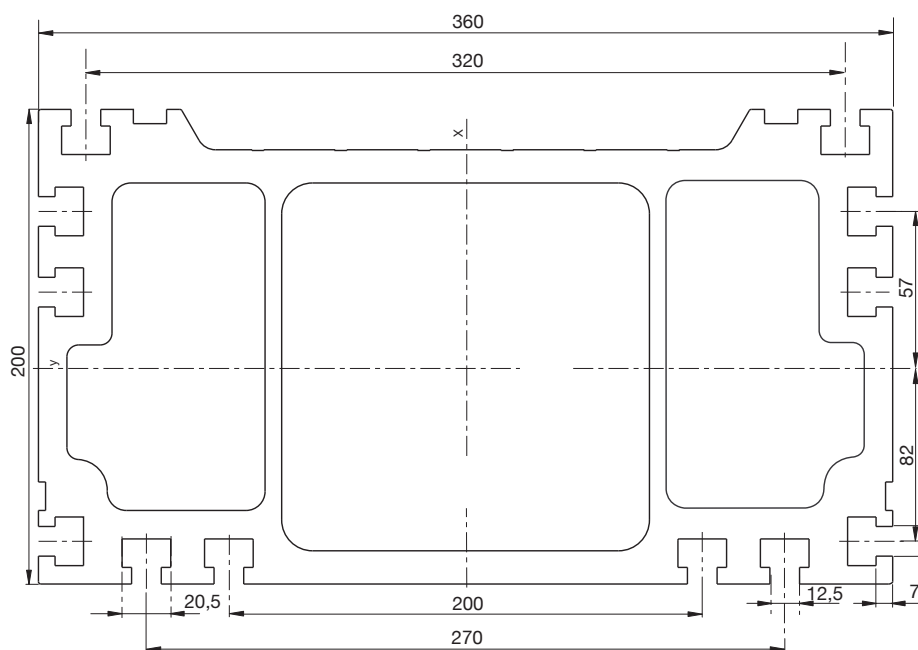

### Solyda (200x360)

Weight per metre	60	[kg/m]
Max. length	12	[m]
Moment of inertia Iy	105,533,000	[mm <sup>4</sup> ]
Moment of inertia Ix	318,687,000	[mm <sup>4</sup> ]
Module	TCRP/S/H 360	
Usually not anodised		

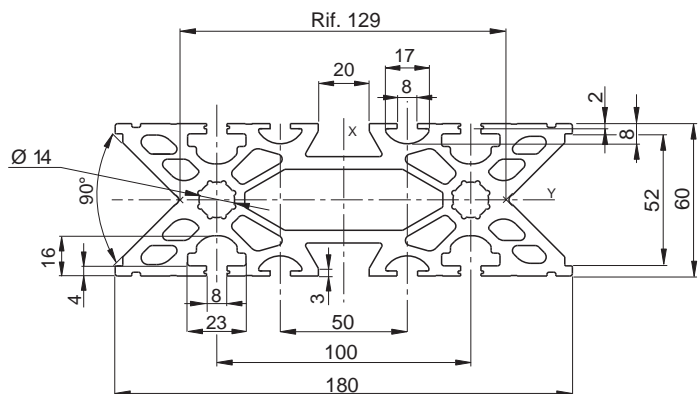

### SYS 1-G

Weight per metre	12	[kg/m]
Max. length	7.5	[m]
Moment of inertia Iy	1,600,000	[mm <sup>4</sup> ]
Moment of inertia Ix	12,350,000	[mm <sup>4</sup> ]
Module	ZCY180	

\*Holes for M16 thread and for PVS connecting elements

## MCR 65

Registered model

HARDENED GUIDE RAILS AND PROFILED ROLLERS

Option: lighter version with pulley seats integrated within the profile

Accessories: see page ML-10

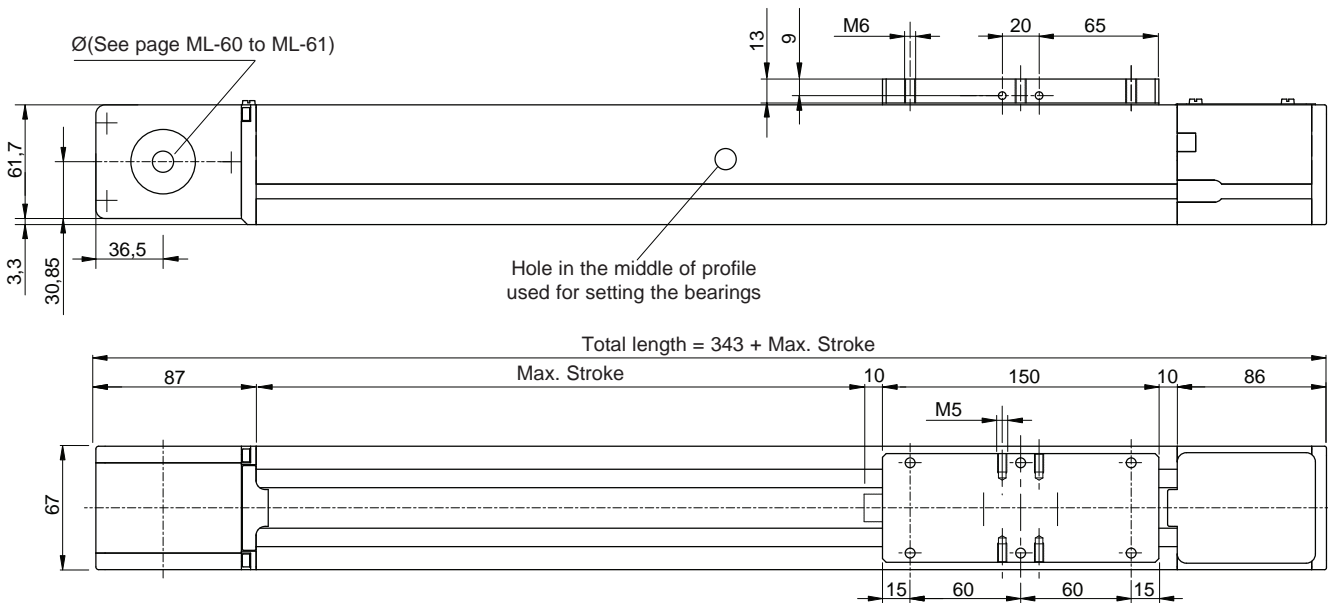

SCREWS FOR BELT TENSION

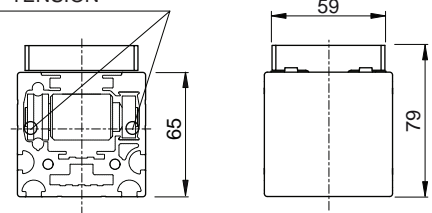

Performances	MCR 65	
Max. stroke	5,830	[mm]
Max. speed	4	[m/s]
Max. acceleration	20	[m/s <sup>2</sup> ]
Repeatability	± 0,1	[mm]
No load torque	-	[mm]

### Suggested working load conditions

Module	M <sub>x</sub> [Nm]	M <sub>y</sub> [Nm]	M <sub>z</sub> [Nm]	F <sub>x</sub> [N]	F <sub>y</sub> [N]	F <sub>z</sub> [N]
MCR 65	45	94	34	1,180	670	1,000

The dynamic values shown do not refer to the max. theoretical load capacity. They include a safety coefficient for automated machinery. In case of peak forces acting together please ask the technical dept

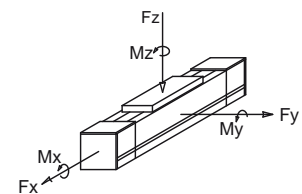

F<sub>x</sub>= Max belt strength

Data	
Belt	32AT05
Slide	Rollers: 4 Ø 24 - 4 Ø 22 [mm]
Load bearing profile	65x67 (see page ML-11)
Pulley Ø	50.93 [mm]
Lead	160 [mm/rev]

Weights	
Inertia of the pulley	- [kgm <sup>2</sup> ]
Belt weight	0.22 [kg/m]
Carriage weight	1 [kg]
Base module (stroke=0)	M <sub>base</sub> =4.4 [kg]
1,000 mm profile	q=5.4 [kg]

To calculate the module weight use the following formula:  $M = M_{base} + q \cdot stroke_{max} / 1,000$  Stroke<sub>max</sub> [mm]

Registered model

Option: lighter version with pulley seats integrated within the profile  
Accessories: see page ML-10

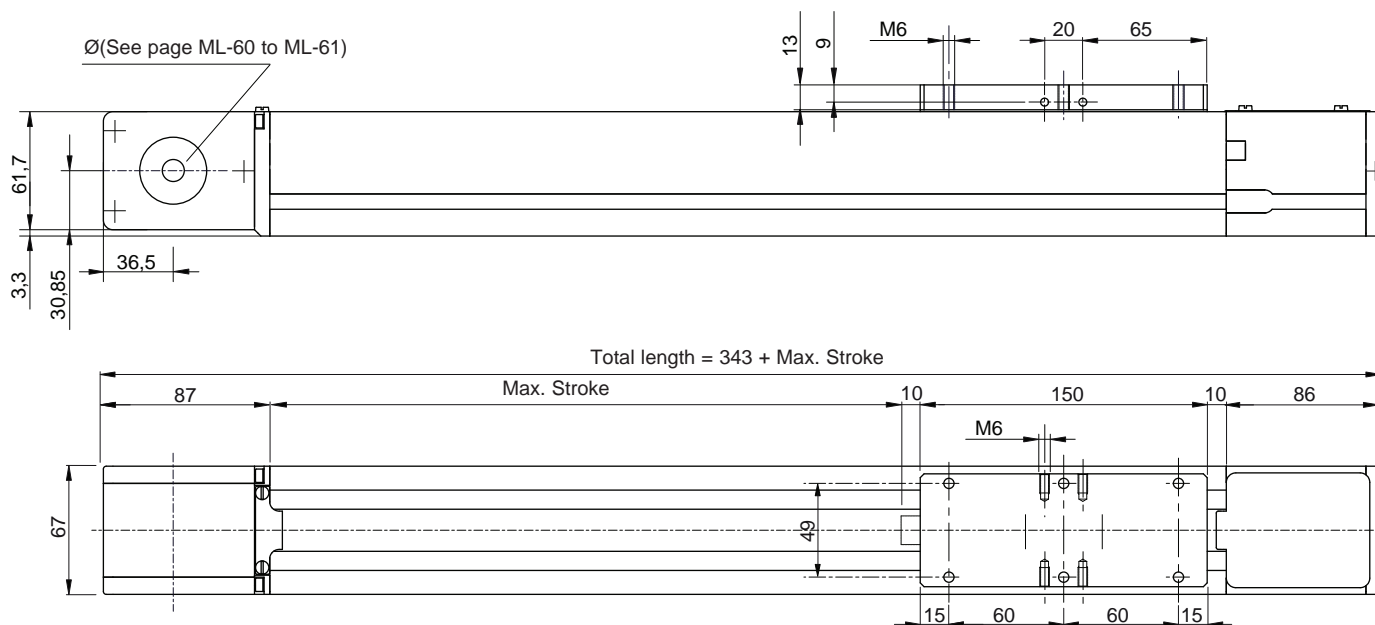

SCREWS FOR BELT TENSION

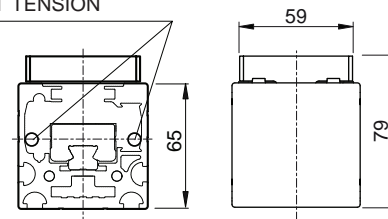

Performances	MCH 65	
Max. stroke	7,830	[mm]
Max. speed	3	[m/s]
Max. acceleration	30	[m/s <sup>2</sup> ]
Repeatability	± 0.1	[mm]
No load torque	-	[mm]

### Suggested working load conditions

Module	M <sub>x</sub> [Nm]	M <sub>y</sub> [Nm]	M <sub>z</sub> [Nm]	F <sub>x</sub> [N]	F <sub>y</sub> [N]	F <sub>z</sub> [N]	F <sub>zB</sub> [N]
MCH 65	19	120	120	1,180	1,960	1,960	1,960

The dynamic values shown do not refer to the max. theoretical load capacity. They include a safety coefficient for automated machinery. In case of peak forces acting together please ask the technical dept

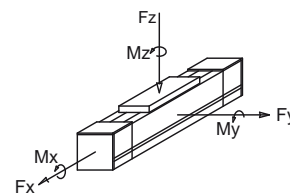

F<sub>x</sub>= Max belt strength

Data	
Belt	32AT05
Slide	2 caged balls roller slides15[mm]
Load bearing profile	65x67 (see page ML-11)
Pulley Ø	50.93 [mm]
Lead	160 [mm/rev]

Weights	
Inertia of the pulley	- [kgm <sup>2</sup> ]
Belt weight	0.22 [kg/m]
Carriage weight	1,1 [kg]
Base module (stroke=0)	M <sub>base</sub> =4.2 [kg]
1,000 mm profile	q=6.2 [kg]

To calculate the module weight use the following formula:  $M = M_{base} + q \cdot stroke_{max} / 1,000$  Stroke<sub>max</sub> [mm]



Registered model

Option: version with additional belt protection (see page ML-70)

Option: short carriage version - code C

Accessories: see page ML-10

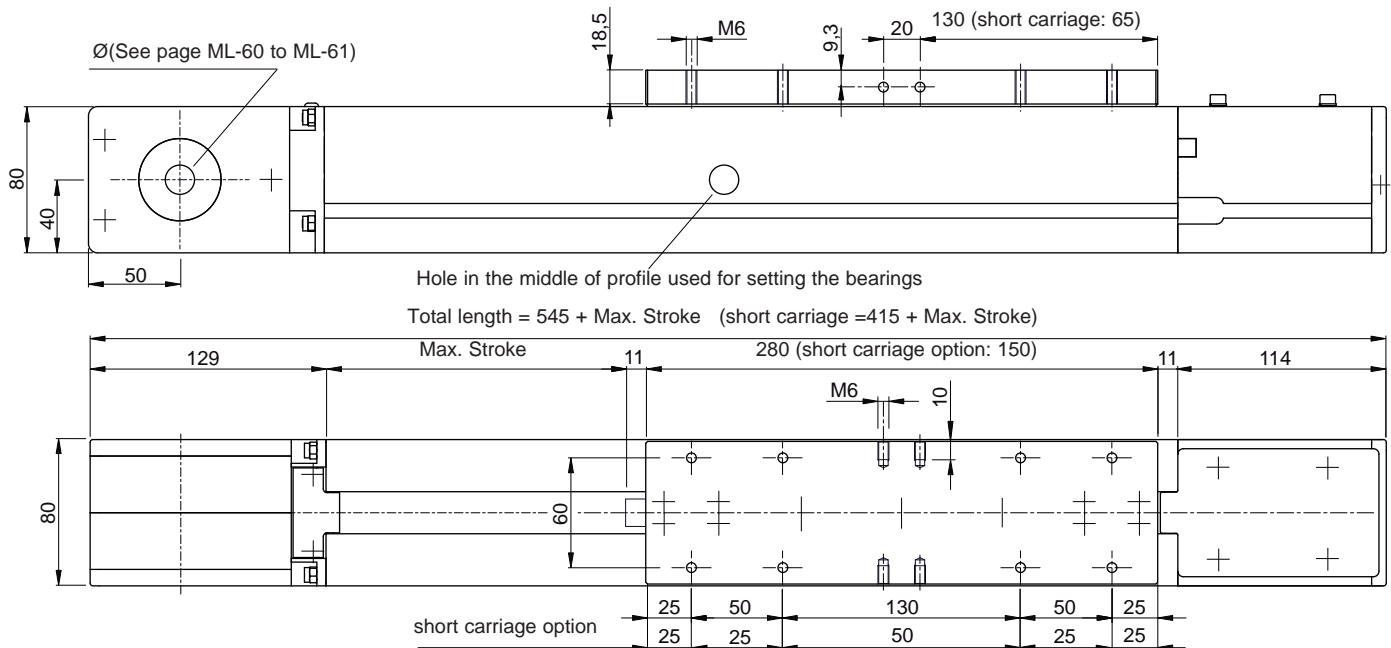

SCREWS FOR BELT TENSION

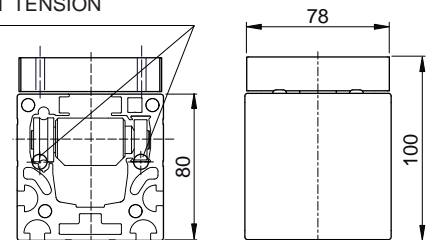

Performances	MCR 80	
Max. stroke	5,700	[mm]
Max. speed	5	[m/s]
Max. acceleration	20	[m/s <sup>2</sup> ]
Repeatability	± 0.1	[mm]
No load torque	0.7	[Nm]

Suggested working load conditions						
Module	M <sub>x</sub> [Nm]	M <sub>y</sub> [Nm]	M <sub>z</sub> [Nm]	F <sub>x</sub> [N]	F <sub>y</sub> [N]	F <sub>z</sub> [N]
MCR 80	51	200	80	2,150	850	1,400

Suggested working load conditions short carriage option						
Module	M <sub>x</sub> [Nm]	M <sub>y</sub> [Nm]	M <sub>z</sub> [Nm]	F <sub>x</sub> [N]	F <sub>y</sub> [N]	F <sub>z</sub> [N]
MCR 80...C	51	100	40	2,150	850	1,400

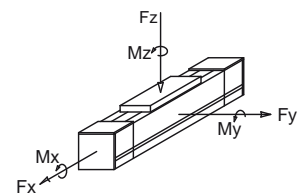

F<sub>x</sub> = Max belt strength

The dynamic values shown do not refer to the max. theoretical load capacity. They include a safety coefficient for automated machinery. In case of peak forces acting together please ask the technical dept

Data	
Belt	32AT10
Slide	Rollers: 4 Ø 24 - 4 Ø 22 [mm]
Load bearing profile	80x80 (see page ML-11)
Pulley Ø	70.03 [mm]
Lead	220 [mm/rev]

Weights	
Inertia of the pulley	0.0010 [kgm <sup>2</sup> ]
Belt weight	0.38 [kg/m]
Carriage weight	2 [kg]
Base module (stroke=0)	M <sub>base</sub> =8 [kg]
1,000 mm profile	q=7 [kg]

To calculate the module weight use the following formula:  $M = M_{base} + q \cdot stroke_{max} / 1,000$  Stroke<sub>max</sub> [mm]

# MCH 80

## GUIDE RAILS WITH CAGED BALL RUNNER BLOCKS

Registered model

Option: version with additional belt protection (see page ML-70)

Option: short carriage version - code C

Accessories: see page ML-10

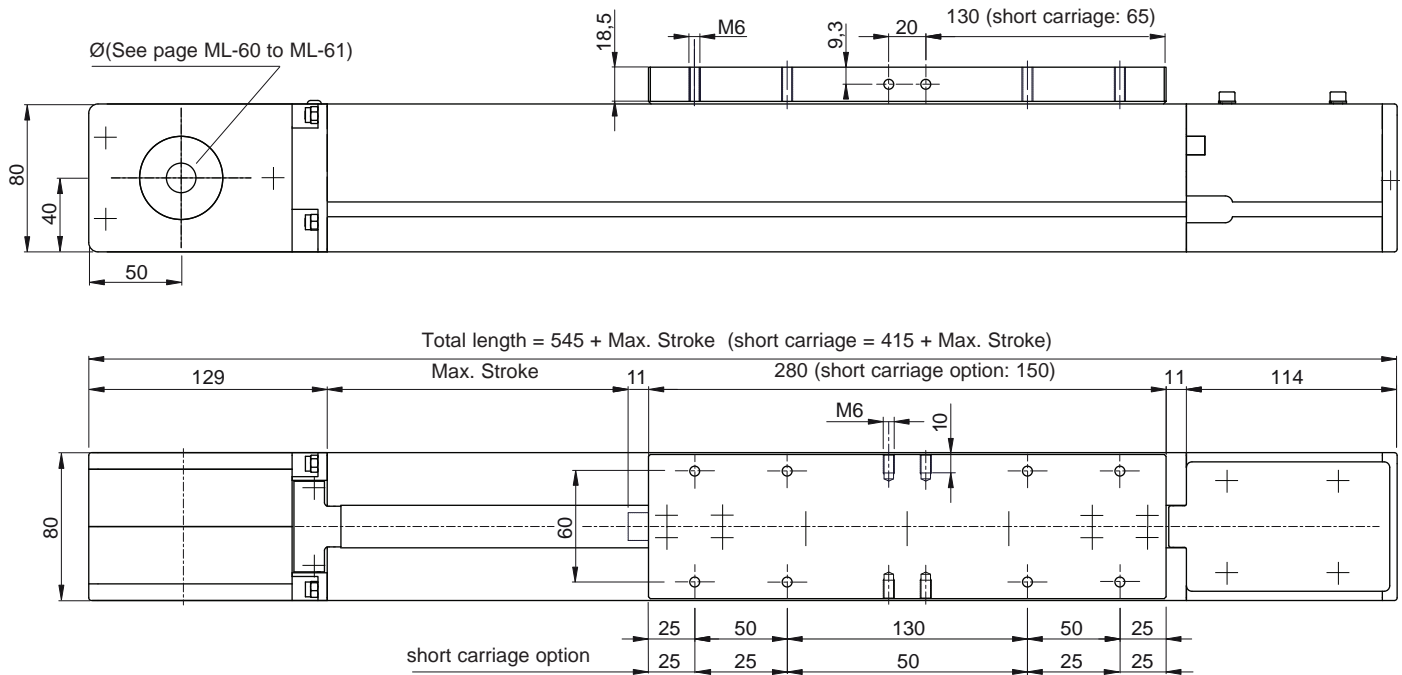

SCREWS FOR BELT TENSION

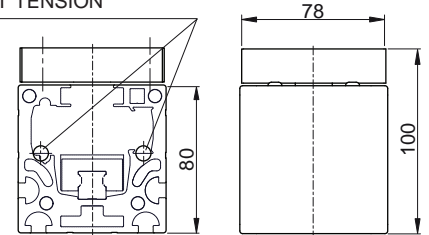

Performances	MCH 80	
Max. stroke	5,700	[mm]
Max. speed	5	[m/s]
Max. acceleration	40	[m/s <sup>2</sup> ]
Repeatability	± 0,1	[mm]
No load torque	0.9	[Nm]

Suggested working load conditions						
Module	M <sub>x</sub> [Nm]	M <sub>y</sub> [Nm]	M <sub>z</sub> [Nm]	F <sub>x</sub> [N]	F <sub>y</sub> [N]	F <sub>z</sub> [N]
MCH 80	30	290	290	2,150	2,900	2,900

Suggested working load conditions						
Module	M <sub>x</sub> [Nm]	M <sub>y</sub> [Nm]	M <sub>z</sub> [Nm]	F <sub>x</sub> [N]	F <sub>y</sub> [N]	F <sub>z</sub> [N]
MCH 80...C	14	15	12	2,150	1,450	1,450

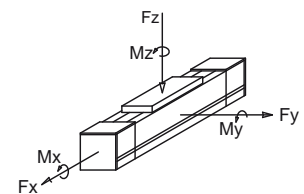

F<sub>x</sub> = Max belt strength

The dynamic values shown do not refer to the max. theoretical load capacity. They include a safety coefficient for automated machinery. In case of peak forces acting together please ask the technical dept

Data	MCS80 - MCH80
Belt	32AT10
Slide	2 caged ball roller slides size 15*
Load bearing profile	80x80 (see page ML- 11)
Pulley Ø	70.03 [mm]
Lead	220 [mm/rev]
* Short carriage option	1 pad

Weights	MCS80 - MCH80	
Inertia of the pulley	0.0010	[kgm <sup>2</sup> ]
Belt weight	0.38	[kg/m]
Carriage weight	2.6	[kg]
Base module (stroke=0)	M <sub>base</sub> =9	[kg]
1,000 mm profile	q=8.2	[kg]

To calculate the module weight use the following formula:  $M = M_{base} + q \cdot \text{stroke}_{max} / 1,000$  Stroke<sub>max</sub> [mm]

Registered model

Option: version with additional belt protection (see page ML-70)  
 \*Option: short carriage version - (code C) or long carriage (code L)  
 Accessories: see page ML-10

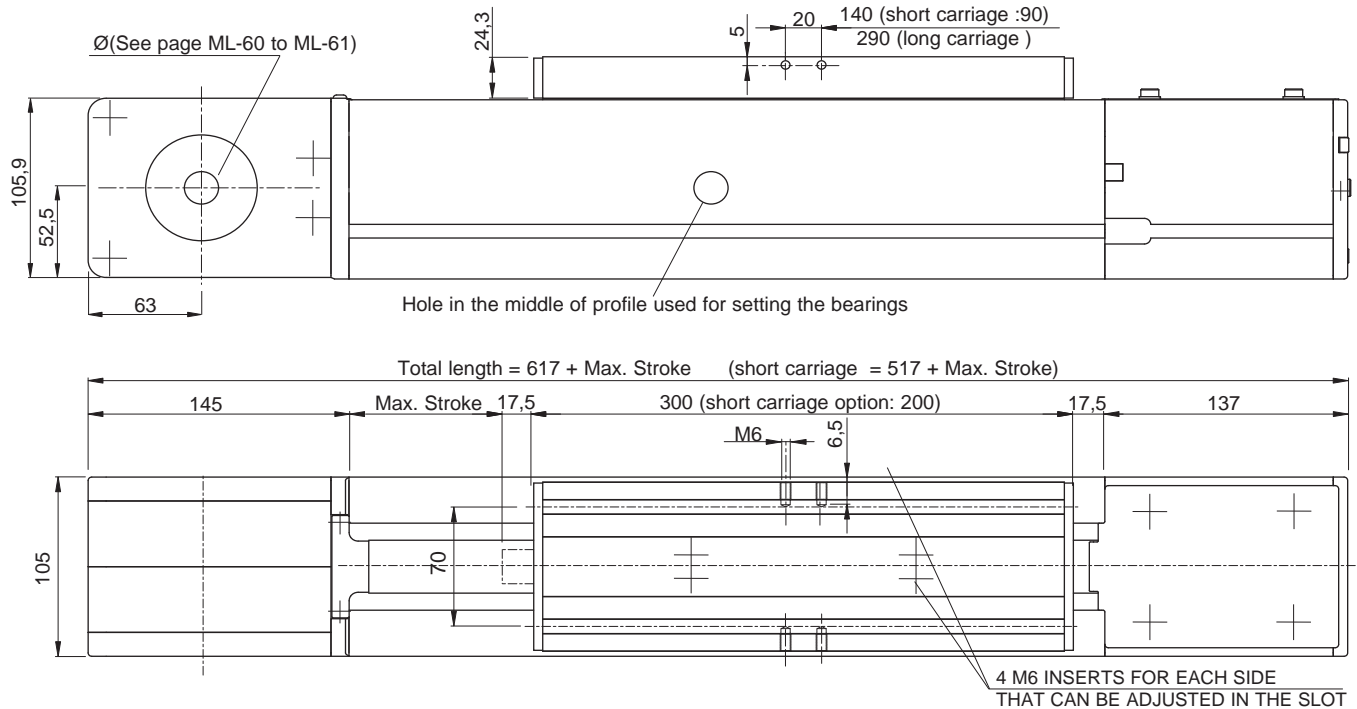

SCREWS FOR BELT TENSION

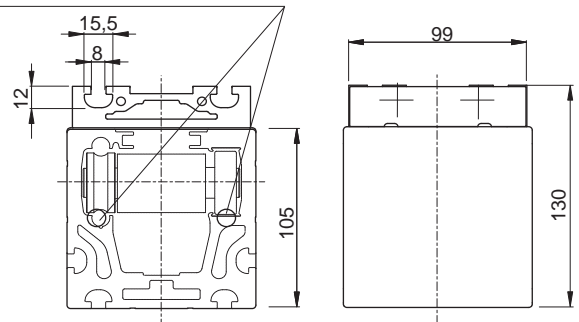

Performances	MCR 105	
Max. stroke	10,100	[mm]
Max. speed	5	[m/s]
Max. acceleration	20	[m/s <sup>2</sup> ]
Repeatability	± 0.1	[mm]
No load torque	1.2	[Nm]

Suggested working load conditions						
Module	M <sub>x</sub> [Nm]	M <sub>y</sub> [Nm]	M <sub>z</sub> [Nm]	F <sub>x</sub> [N]	F <sub>y</sub> [N]	F <sub>z</sub> [N]
MCR 105	185	580	220	3,300	1,500	2,950

Suggested working load conditions short carriage option						
Module	M <sub>x</sub> [Nm]	M <sub>y</sub> [Nm]	M <sub>z</sub> [Nm]	F <sub>x</sub> [N]	F <sub>y</sub> [N]	F <sub>z</sub> [N]
MCR 105...C	185	330	130	3,300	1,450	2,950

The dynamic values shown do not refer to the max. theoretical load capacity. They include a safety coefficient for automated machinery. In case of peak forces acting together please ask the technical dept

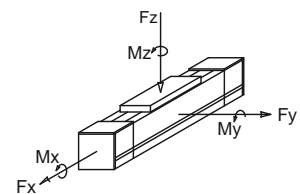

F<sub>x</sub>= Max belt strength

Data	
Belt	40AT10
Slide	Rollers: 4 Ø 37 - 4 Ø 35 [mm]
Load bearing profile	105x105 (see page ML-11)
Pulley Ø	92.31 [mm]
Lead	290 [mm/rev]

Weights		
Inertia of the pulley	0.0037	[kgm <sup>2</sup> ]
Belt weight	0.47	[kg/m]
Carriage weight	3.5	[kg]
Base module (stroke=0)	M <sub>base</sub> =16.5	[kg]
1,000 mm profile	q=13	[kg]

To calculate the module weight use the following formula:  $M = M_{base} + q \cdot stroke_{max} / 1,000$  Stroke<sub>max</sub> [mm]

# MCH 105

## GUIDE RAILS WITH CAGED BALL RUNNER BLOCKS

Registered model

Option: version with additional belt protection (see page ML-70)

\*Option: short carriage version - (code C)

Accessories: see page ML-10

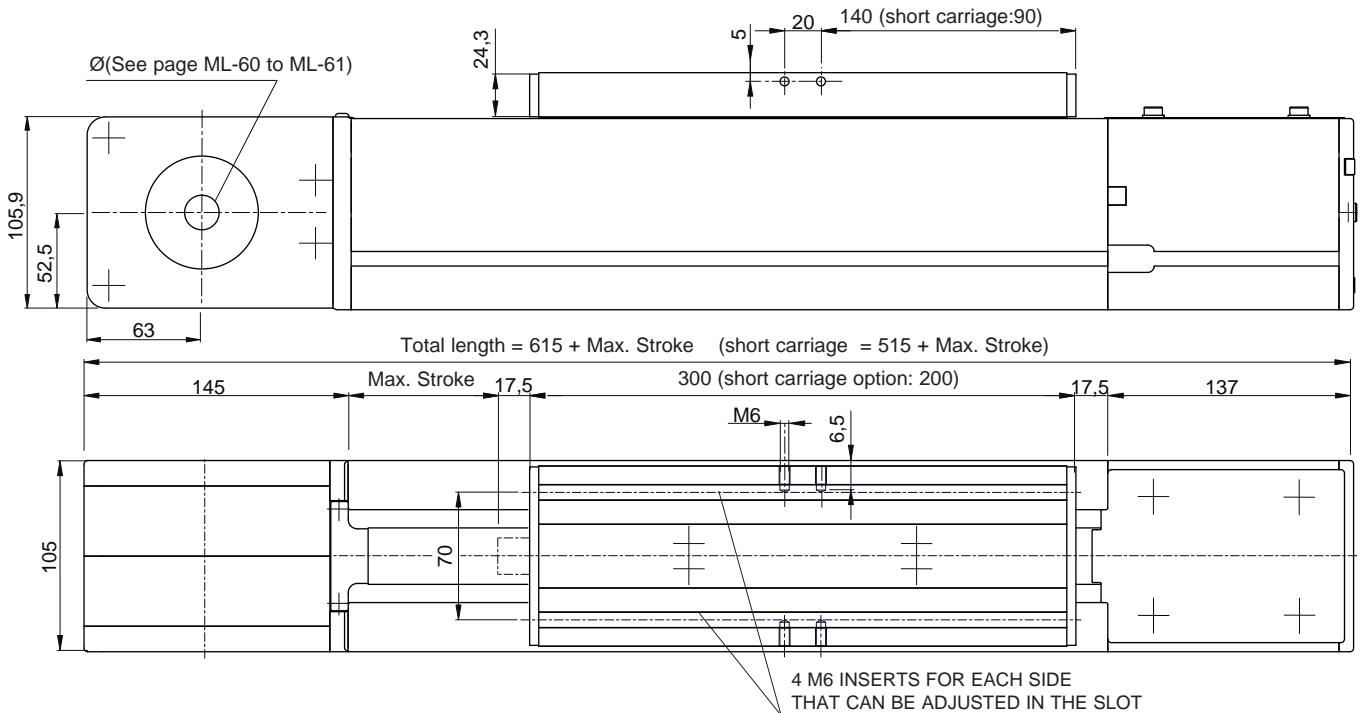

### SCREWS FOR BELT TENSION

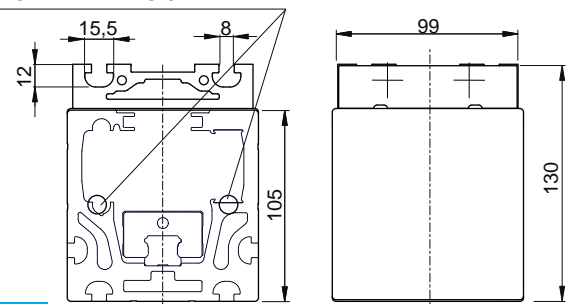

Performances	MCH 105	
Max. stroke	10,100	[mm]
Max. speed	5	[m/s]
Max. acceleration	50	[m/s <sup>2</sup> ]
Repeatability	± 0.1	[mm]
No load torque	1.5	[Nm]

### Suggested working load conditions

Module	M <sub>x</sub> [Nm]	M <sub>y</sub> [Nm]	M <sub>z</sub> [Nm]	F <sub>x</sub> [N]	F <sub>y</sub> [N]	F <sub>z</sub> [N]
MCH 105	116	600	600	3,300	6,030	6,030

### Suggested working load conditions short carriage option

Module	M <sub>x</sub> [Nm]	M <sub>y</sub> [Nm]	M <sub>z</sub> [Nm]	F <sub>x</sub> [N]	F <sub>y</sub> [N]	F <sub>z</sub> [N]
MCH 105...C	36	30	30	3,300	3,018	3,018

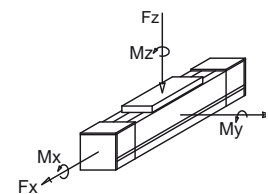

F<sub>x</sub> = Max belt strength

The dynamic values shown do not refer to the max. theoretical load capacity. They include a safety coefficient for automated machinery. In case of peak forces acting together please ask the technical dept

### Constuctive data

Belt	40AT10
Slide	2 caged ball roller slides size 20*
Load bearing profile	105x105 (see page ML- 11)
Pulley Ø	92.31 [mm]
Lead	290 [mm/rev]

\* Short carriage option 1 pad

### Weights

Inertia of the pulley	0.0037	[kgm <sup>2</sup> ]
Belt weight	0.47	[kg/m]
Carriage weight	4.5	[kg]
Base module (stroke=0)	M <sub>base</sub> =18	[kg]
1,000 mm profile	q=14.3	[kg]

To calculate the module weight use the following formula:  $M = M_{base} + q \cdot stroke_{max} / 1,000$  Stroke<sub>max</sub> [mm]

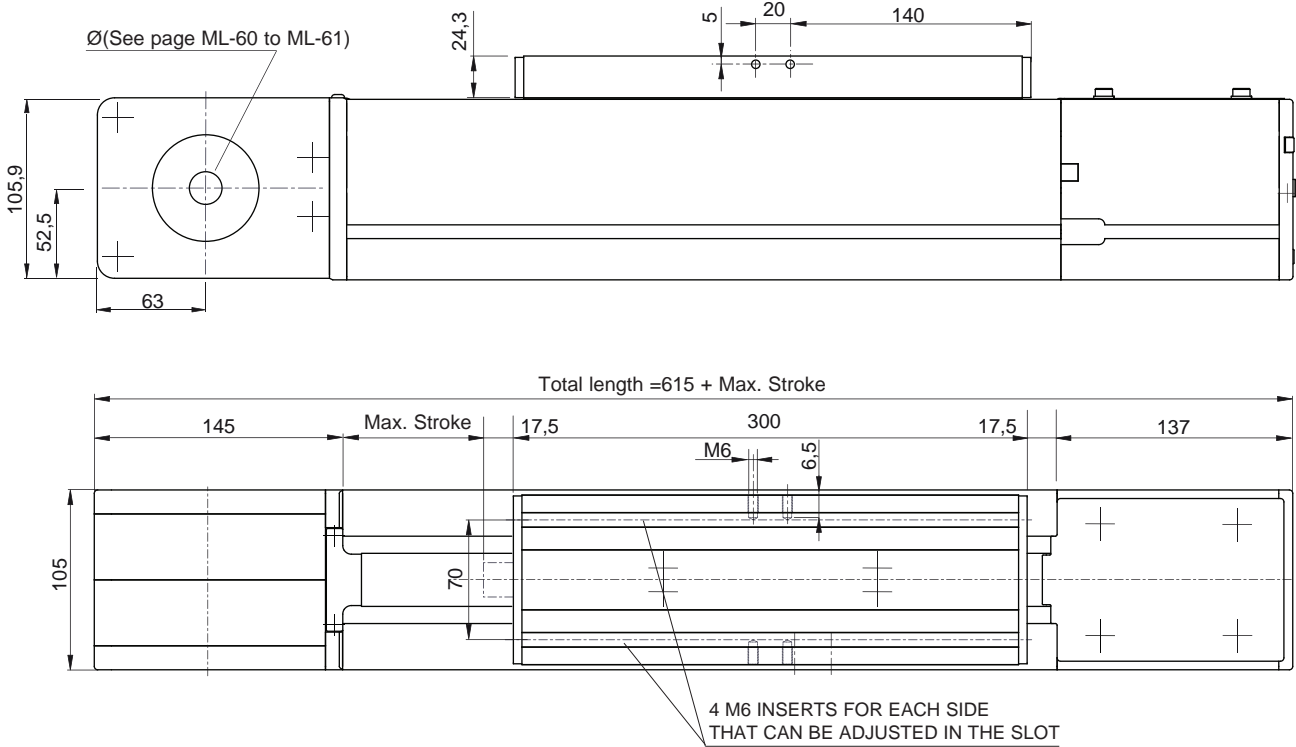

SCREWS FOR BELT TENSION

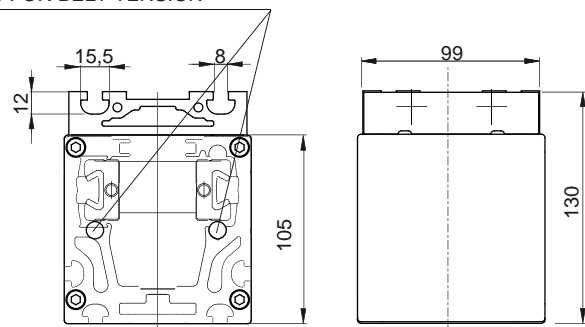

Performances	MCHH 105	
Max. stroke	7,400	[mm]
Max. speed	5	[m/s]
Max. acceleration	50	[m/s <sup>2</sup> ]
Repeatability	± 0.1	[mm]
No load torque	2.2	[Nm]

Suggested working load conditions						
Module	M <sub>x</sub> [Nm]	M <sub>y</sub> [Nm]	M <sub>z</sub> [Nm]	F <sub>x</sub> [N]	F <sub>y</sub> [N]	F <sub>z</sub> [N]
MCHH 105 210	210	1.033	700	3,300	7,200	6,210

The dynamic values shown do not refer to the max. theoretical load capacity. They include a safety coefficient for automated machinery. In case of peak forces acting together please ask the technical dept

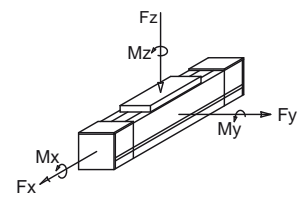

F<sub>x</sub>= Max belt strength

Data	
Belt	40ATL10
Slide	4 caged ball roller slides size 15
Load bearing profile	105x105 (see page ML- 11)
Pulley Ø	92.31 [mm]
Lead	290 [mm/rev]

Weights	
Inertia of the pulley	0.0037 [kgm <sup>2</sup> ]
Belt weight	0.47 [kg/m]
Carriage weight	4.5 [kg]
Base module (stroke=0)	M <sub>base</sub> =18 [kg]
1,000 mm di profile	q=14 [kg]

To calculate the module weight use the following formula:  $M = M_{base} + q \cdot stroke_{max} / 1,000$  Stroke<sub>max</sub> [mm]

# Modules with Screw Drive

## MVR 80

HARDENED GUIDES  
WITH CYLINDRICAL ROLLERS - TRAPEZOIDAL BALL SCREW

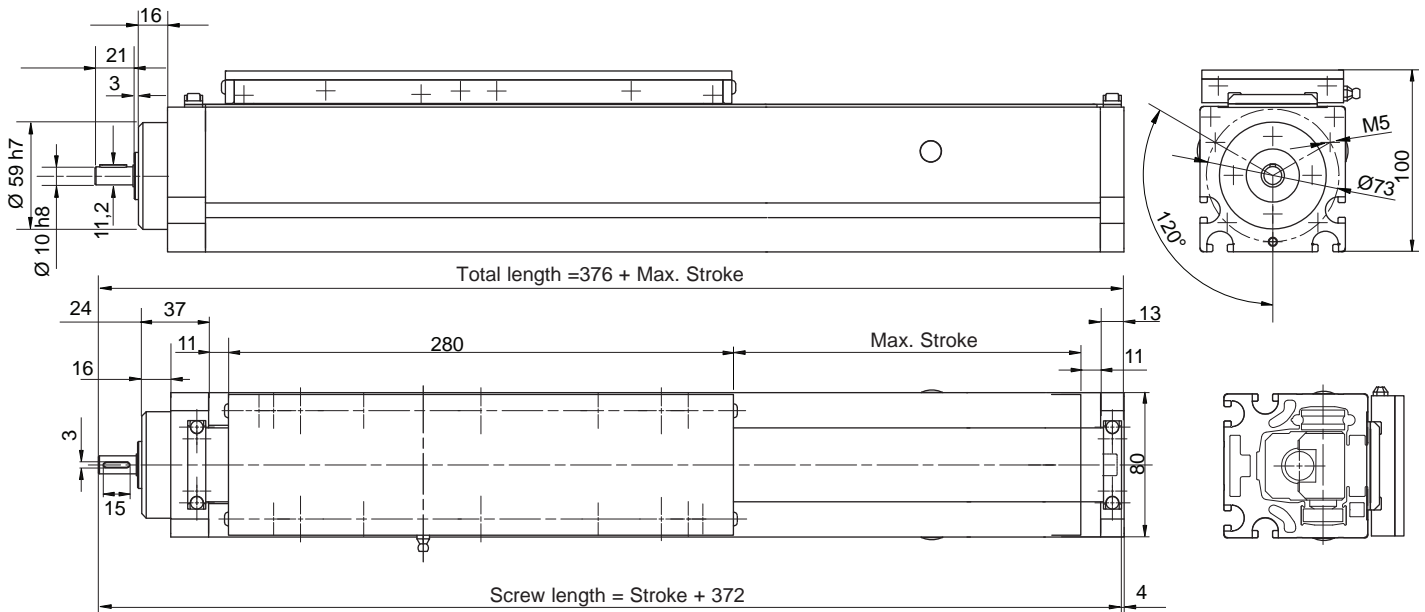

Code	M	V	R				
V = Ball screw							
R = Rollers							
Max. Stroke						[mm]	
Module total length							[mm]
Type of carriage							N/D
Screw pitch							5-10
Pedestal bearings							SI

Critical Speed Graph

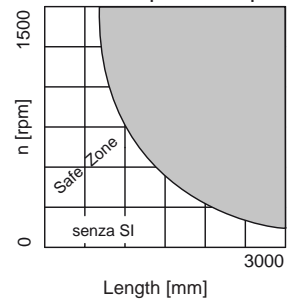

Max. stroke-speed limit over which some support bearings are required (SI) to avoid an excessive screw vibration. The working point marked inside the broken line is not recommended.

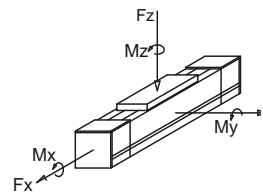

Fx= Max belt strength

Performances		MVR 80	
Max. stroke		2,500	[mm]
Max. speed	Pitch 5	0.15	[m/s]
	Pitch 10	0.30	[m/s]
	Pitch 16	0.50	[m/s]
Max. acceleration		5	[m/s <sup>2</sup> ]
Repeatability		± 0,05	[mm]

### Suggested working load conditions

Module	M <sub>x</sub> [Nm]	M <sub>y</sub> [Nm]	M <sub>z</sub> [Nm]	F <sub>x</sub> [N]	F <sub>y</sub> [N]	F <sub>z</sub> [N]
MVR 80	51	200	80	*1,600	850	1,400

The values shown refer to maximum performance with each force acting individually. The dynamic data shown do not refer to the max. theoretical load capacity. They include a safety coefficient for automated machinery.

(\*) With a pitch of 5 mm

Data	
Slide	Rollers: 4 Ø24 - 4 Ø22 [mm]
Beam	80x80 (see page ML-11)
Ø screw	16 [mm]
Length of the screw	367+ <sub>max</sub> stroke [mm]

Weights	
Inertia of the worm	0.0003 • L. screw(m) [kgm <sup>2</sup> ]
Carriage weight	2.5 c.a. [kg]
Base module (stroke=0)	M <sub>base</sub> = 5.5 approx. [kg]
1,000 mm profile	q=8 approx. [kg]

To calculate the module weight use the following formula:  $M = M_{base} + q \cdot stroke_{max} / 1,000$  Stroke<sub>max</sub> [mm]



Registered model

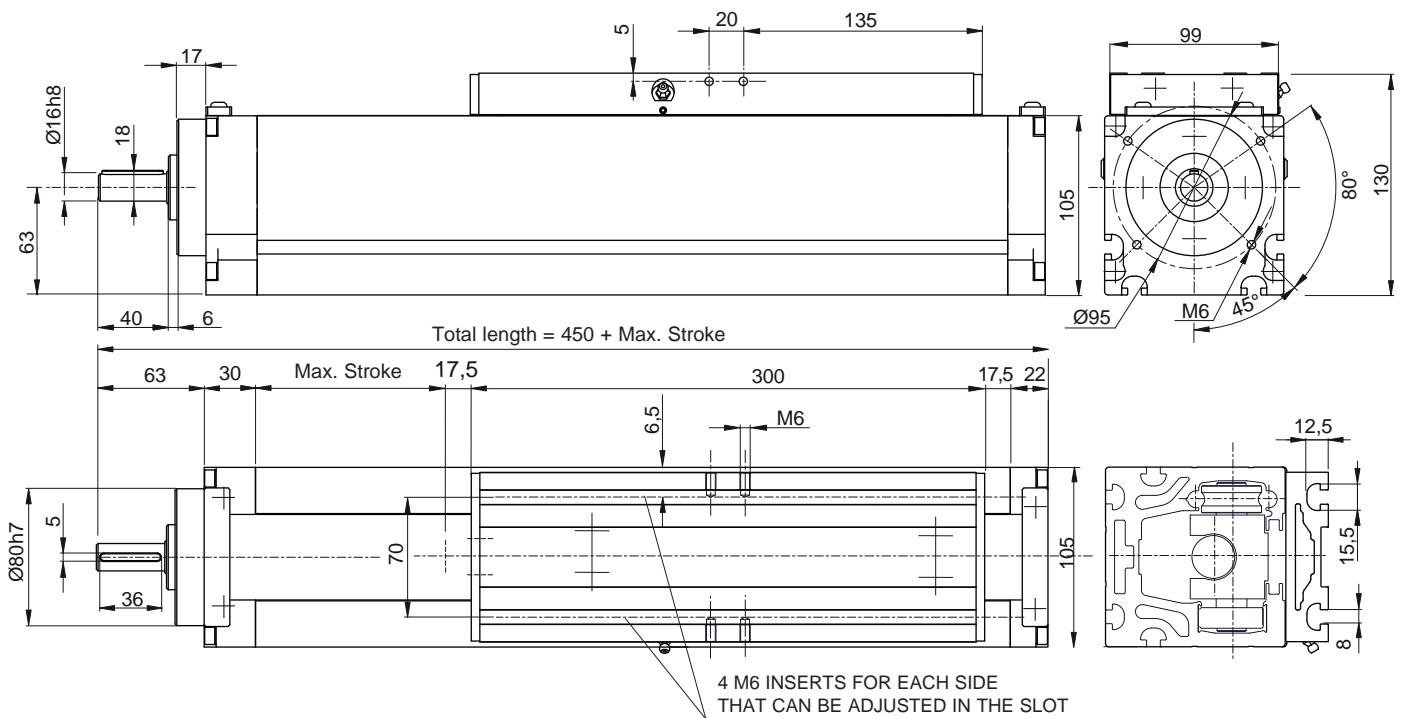

Code	M	V	R				
V = Ball screw							
R = Rollers							
Max. stroke						[mm]	
Module total length						[mm]	
Type of carriage						N/D	
Screw pitch						5-10-25-50	
Pedestal bearings							SI

Critical Speed Graph

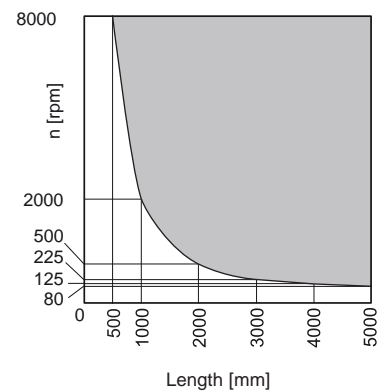

Max. stroke-speed limit over which some support bearings are required (SI) to avoid an excessive screw vibration. The working point marked inside the broken line is not recommended.

### Performances MVR 105

Max. stroke	Pitch 5 -10 = 4550	Pitch 25 = 5,150	[mm]
Max. speed	Pitch 5 [mm]	0.15	[m/s]
	Pitch 10 [mm]	0.30	[m/s]
	Pitch 25 [mm]	0.75	[m/s]
Max. acceleration		5	[m/s <sup>2</sup> ]
Repeatability		± 0.05	[mm]

### Suggested working load conditions

Module	M <sub>x</sub> [Nm]	M <sub>y</sub> [Nm]	M <sub>z</sub> [Nm]	F <sub>x</sub> [N]	F <sub>y</sub> [N]	F <sub>z</sub> [N]
MVR 105	185	580	220	*2,000	1,500	2,950

The values shown refer to maximum performance with each force acting individually. The dynamic data shown do not refer to the max. theoretical load capacity. They include a safety coefficient for automated machinery.

(\*) With a pitch of 5 mm

### Data

Slide	Rollers: 4 Ø 37 - 4 Ø 35 [mm]
Beam	105x105 (see page ML-11)
Ø screw	25 [mm]
Length of the screw	440+ <sub>max</sub> stroke [mm]

### Weights

Inertia of the worm	0.0003 • L. screw(m) [kgm <sup>2</sup> ]
Carriage weight	4 approx. [kg]
Base module (stroke=0)	M <sub>base</sub> =11 [kg]
1,000 mm profile	q=17.2 approx. [kg]

To calculate the module weight use the following formula:  $M = M_{base} + q \cdot stroke_{max} / 1,000$  Stroke<sub>max</sub> [mm]

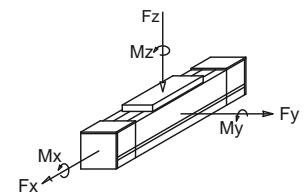

F<sub>x</sub> = Max belt strength

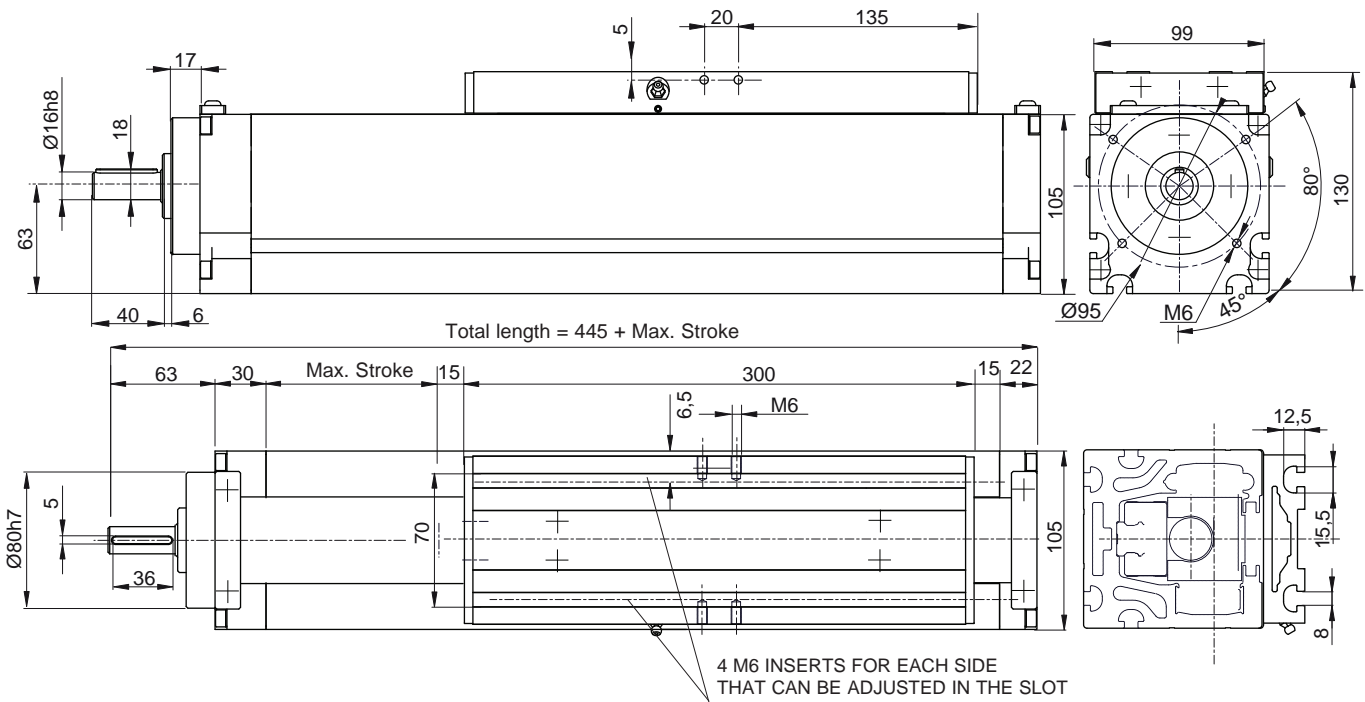

Code	M	V	L					
V = Ball screw								
S = Caged ball roller slides								
H = Ball roller slides								
Max. stroke				[mm]				
Module total length					[mm]			
Type of carriage						N/D		
Screw pitch							5-10-25	
Pedestal bearings								SI

Critical Speed Graph

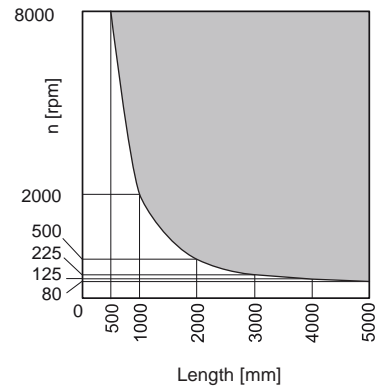

Max. stroke-speed limit over which some support bearings are required (SI) to avoid an excessive screw vibration. The working point marked inside the broken line is not recommended.

Performances	MVS 105	MVH 105	
Max. stroke	Pitch 5 -10 = 4,550	Pitch 25 = 5,150	[mm]
Max. speed	Pitch 5 [mm]	0.15	0.15 [m/s]
	Pitch 10 [mm]	0.30	0.30 [m/s]
	Pitch 25 [mm]	0.75	0.75 [m/s]
Max. acceleration		5	5 [m/s <sup>2</sup> ]
Repeatability		± 0.05	± 0.05 [mm]

**Suggested working load conditions**

Module	M <sub>x</sub> [Nm]	M <sub>y</sub> [Nm]	M <sub>z</sub> [Nm]	F <sub>x</sub> [N]	F <sub>y</sub> [N]	F <sub>z</sub> [N]
MVS 105	156	800	800	3,000(*)	9,550	9,550
MVH 105	116	600	600	3,000(*)	6,030	6,030

The values shown refer to maximum performance with each force acting individually. The dynamic data shown do not refer to the max. theoretical load capacity. They include a safety coefficient for automated machinery.

(\*) With a pitch of 5 mm

Data	
Slide	2 caged ball roller slides size 20
Beam	105x105 (see page ML- 11)
Ø screw	25 [mm]
Length of the screw	440+ <sub>max</sub> stroke [mm]

Weights	
Inertia of the worm	0.0003 • L. screw(m) [kgm <sup>2</sup> ]
Carriage weight	4 approx. [kg]
Base module (stroke=0)	M <sub>base</sub> =12 [kg]
1,000 mm profile	q=17.2 approx. [kg]

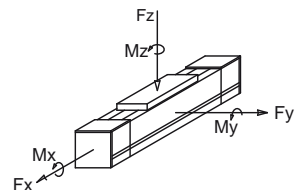

F<sub>x</sub>= Max belt strength

To calculate the module weight use the following formula:  $M = M_{base} + q \cdot stroke_{max} / 1,000$  Stroke<sub>max</sub> [mm]

Registered model

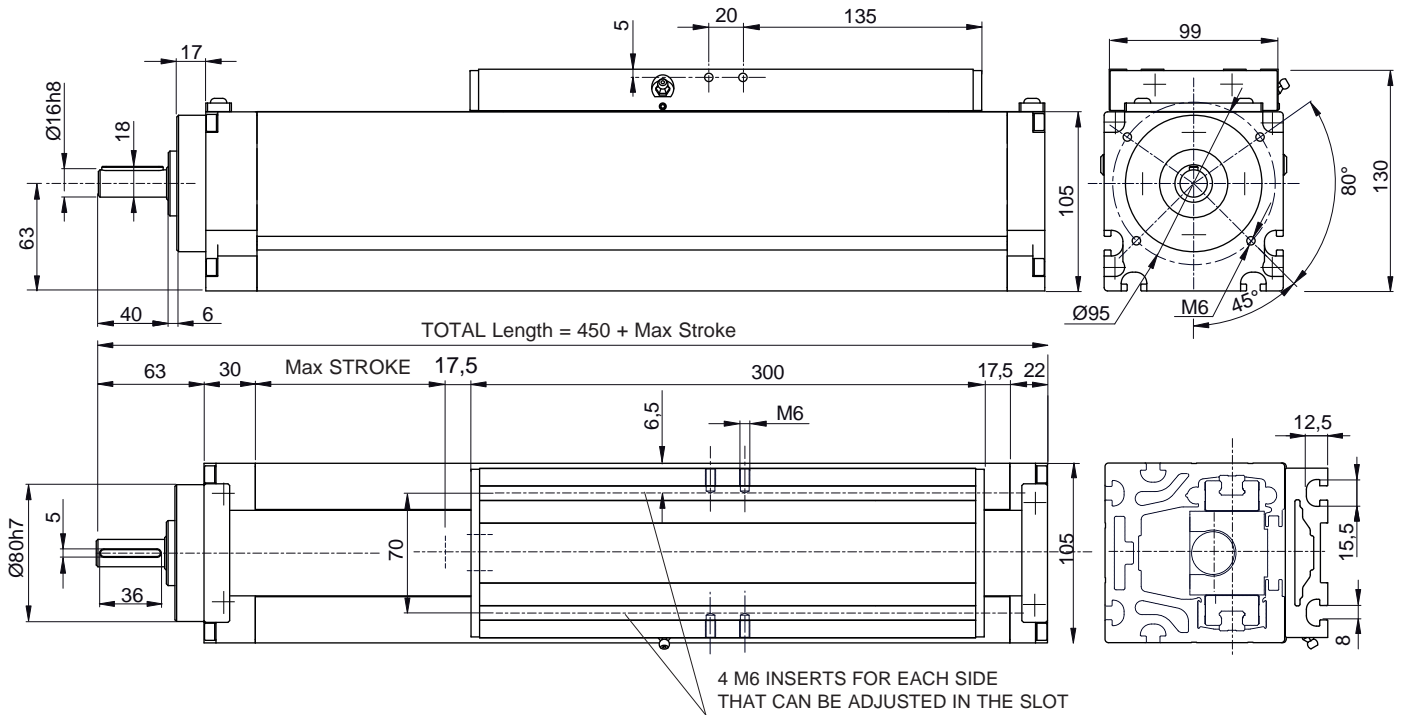

Code	M	V	HH				
V=ball screw							
H=ball roller slides							
Max Stroke				[mm]			
Module total length					[mm]		
Type of carriage						N/D	
Screw pitch							5-10-25
Pedestal bearings							SI

Performances		MVHH 105		
Max Stroke	Pitch 5 -10 = 4550	Pitch 25 = 5150		[mm]
Max Speed	Pitch 5	[mm]	0,15	[m/s]
	Pitch 10	[mm]	0,30	[m/s]
	Pitch 25	[mm]	0,75	[m/s]
Max acceleration			5	[m/s <sup>2</sup> ]
Repeatability			± 0,05	[mm]

Suggested working load conditions						
Module	M <sub>x</sub> [Nm]	M <sub>y</sub> [Nm]	M <sub>z</sub> [Nm]	F <sub>x</sub> [N]	F <sub>y</sub> [N]	F <sub>z</sub> [N]
MVHH 105	185	500	500	*3.000	6.000	6.000

The values shown refer to maximum performance with each force acting individually. The dynamic data shown do not refer to the max. theoretical load capacity. They include a safety coefficient for automated machinery.

(\* With a pitch of 5 mm)

Data	
Slide	4 caged ball roller slides size 15
Beam	105x105 (see page ML- 11)
Ø screw	25 [mm]
Length of the screw	440+stroke <sub>max</sub> [mm]

Weights	
Inertia of the worm	0,0003 • L. screw(m) [kgm <sup>2</sup> ]
Carriage weight	4 c.a. [kg]
Base module (stroke=0)	M <sub>base</sub> =13 [kg]
1,000 mm profile	q=17,5 approx. [kg]

To calculate the module weight use the following formula:  $M = M_{base} + q \cdot stroke_{max} / 1,000$  Stroke<sub>max</sub> [mm]

Critical Speed Graph

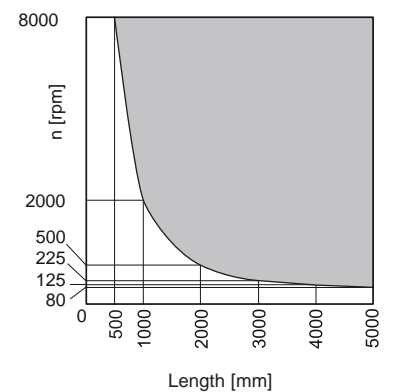

Max. stroke-speed limit over which some support bearings are required (SI) to avoid an excessive screw vibration. The working point marked inside the broken line is not recommended.

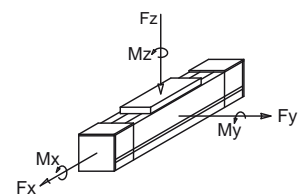

F<sub>x</sub> = Max belt strength

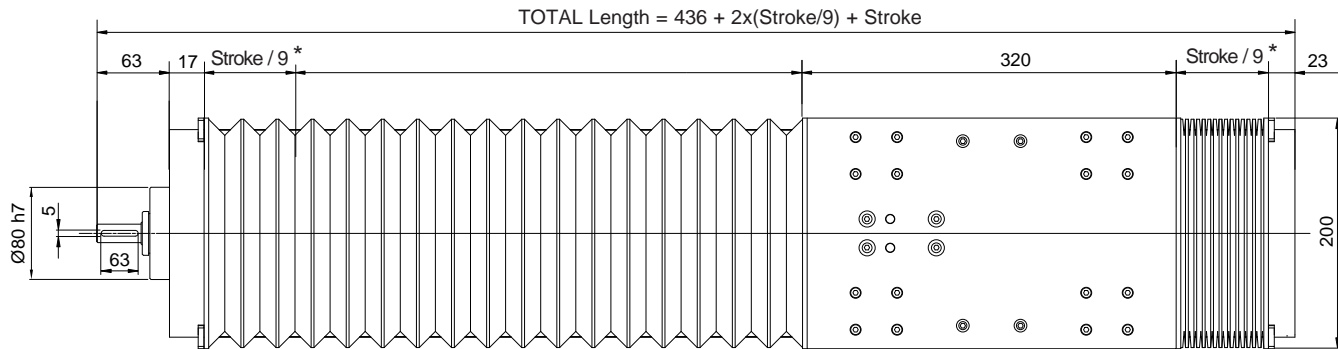
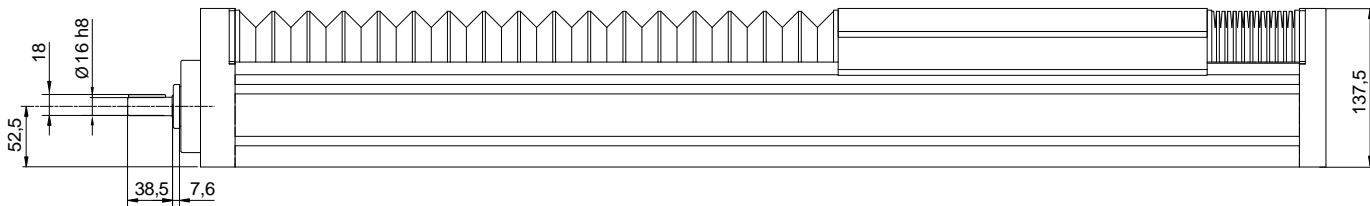

\*valore indicativo

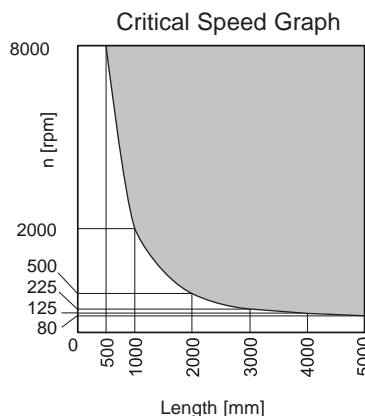

Max. stroke-speed limit over which some support bearings are required (SI) to avoid an excessive screw vibration. The working point marked inside the broken line is not recommended.

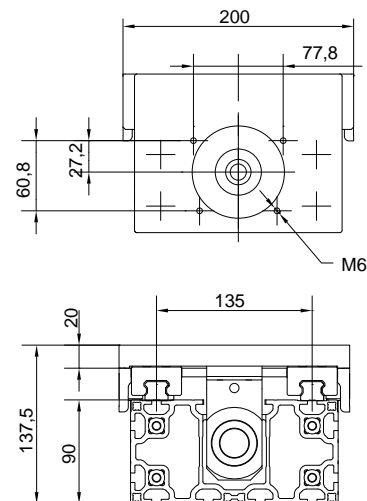

### Performances TVH 180

Max Stroke	Pitch 5 -10 = 4550	Pitch 25 = 5150	[mm]
Max Speed	Pitch 5 [mm]	0,15	[m/s]
	Pitch 10 [mm]	0,30	[m/s]
	Pitch 25 [mm]	0,75	[m/s]

### Suggested working load conditions

Module	$M_x$ [Nm]	$M_y$ [Nm]	$M_z$ [Nm]	$F_x$ [N]	$F_y$ [N]	$F_z$ [N]
TVH 180	600	850	850	*3.000	9.200	9.200

The values shown refer to maximum performance with each force acting individually. The dynamic data shown do not refer to the max. theoretical load capacity. They include a safety coefficient for automated machinery.

(\*) With a pitch of 5 mm

### Data

Slide	4 caged ball roller slides size 20
Beam	E01-5 (see page ML-12)
Ø screw	25 [mm]
Bellow	heat-sealed, plastic

### Weights

Inertia of the worm	$0,0003 \cdot L \cdot \text{screw}(m)$ [kgm <sup>2</sup> ]
Carriage weight	7 [kg]
Base module (stroke=0)	$M_{\text{base}} = 20$ [kg]
1,000 mm profile	$q = 20$ [kg]

To calculate the module weight use the following formula:  $M = M_{\text{base}} + q \cdot \text{stroke}_{\text{max}} / 1,000$  Stroke<sub>max</sub> [mm]

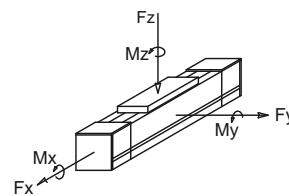

$F_x = \text{Max belt strength}$

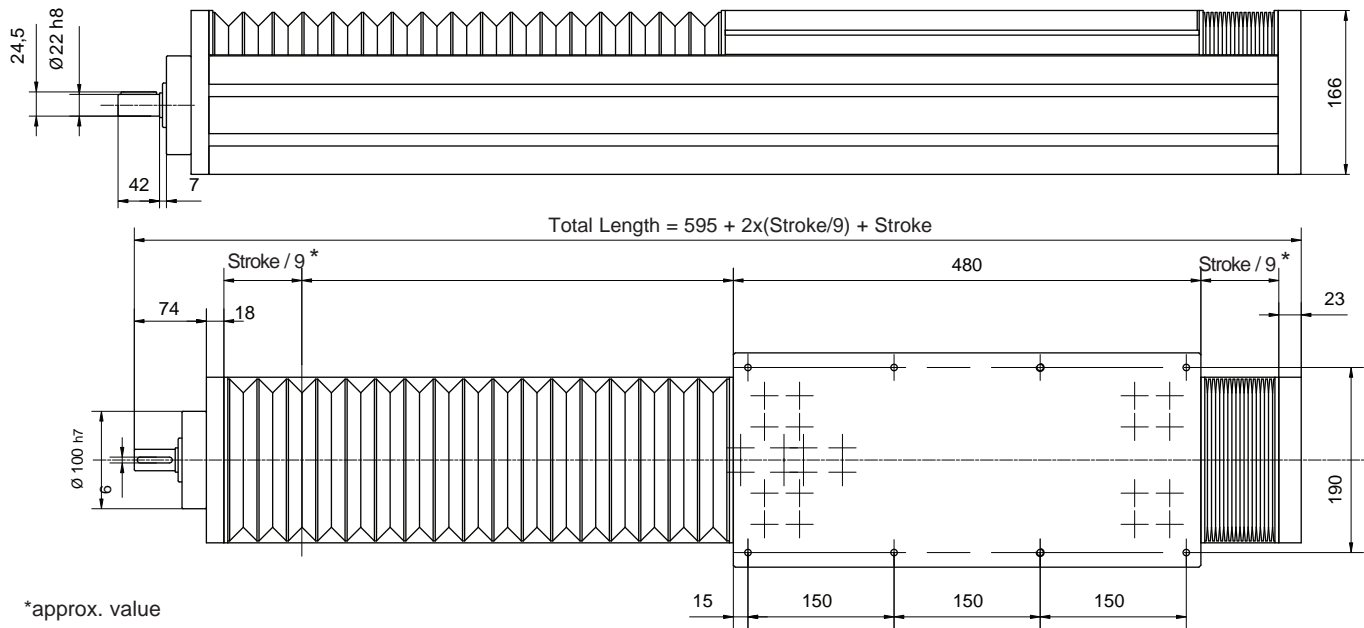

\*approx. value

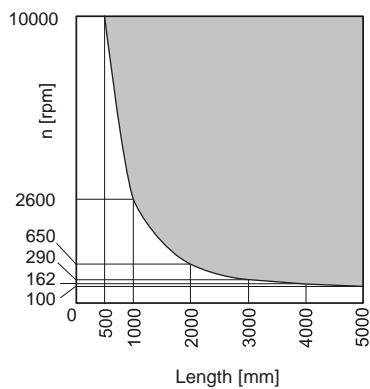

Max. stroke-speed limit over which some support bearings are required (SI) to avoid an excessive screw vibration. The working point marked inside the broken line is not recommended.

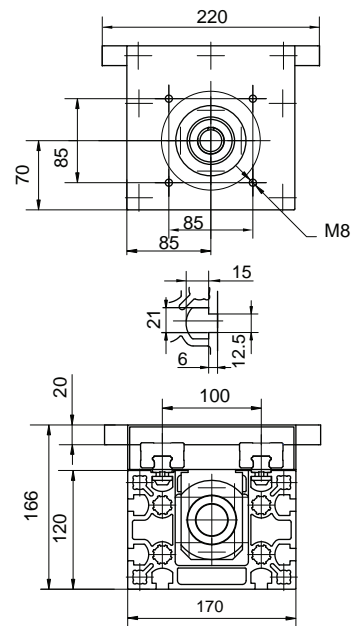

Performances		TVS 170	
Max. stroke		4,000	[mm]
Max. speed	Pitch 5	0.15	[m/s]
	Pitch 10	0.30	[m/s]
	Pitch 20	0.75	[m/s]
	Pitch 32	1.00	[m/s]

Suggested working load conditions						
Module	$M_x$ [Nm]	$M_y$ [Nm]	$M_z$ [Nm]	$F_x$ [N]	$F_y$ [N]	$F_z$ [N]
TVS 170	720	2,050	2,050	*6,000	11,950	11,950

The dynamic values shown do not refer to the max. theoretical load capacity. They include a safety coefficient for automated machinery. In case of peak forces acting together please ask the technical dept.

(\* With a pitch of 10 mm)

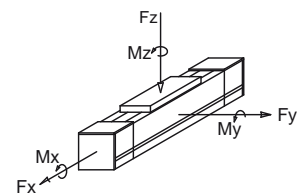

$F_x$  = Max belt strength

Data	
Slide	4 caged ball roller slides size 20
Beam	Statyca (see page ML-13)
$\varnothing$ screw	32 [mm]
Bellow	heat-sealed, plastic

Weights	
Inertia of the worm	$0,0006 \cdot L \cdot \text{screw}(m)$ [kgm <sup>2</sup> ]
Carriage weight	11 [kg]
Base module (stroke=0)	$M_{\text{base}} = 36$ [kg]
1,000 mm profile	$q = 28$ [kg]

To calculate the module weight use the following formula:  $M = M_{\text{base}} + q \cdot \text{stroke}_{\text{max}} / 1,000$  Stroke<sub>max</sub> [mm]

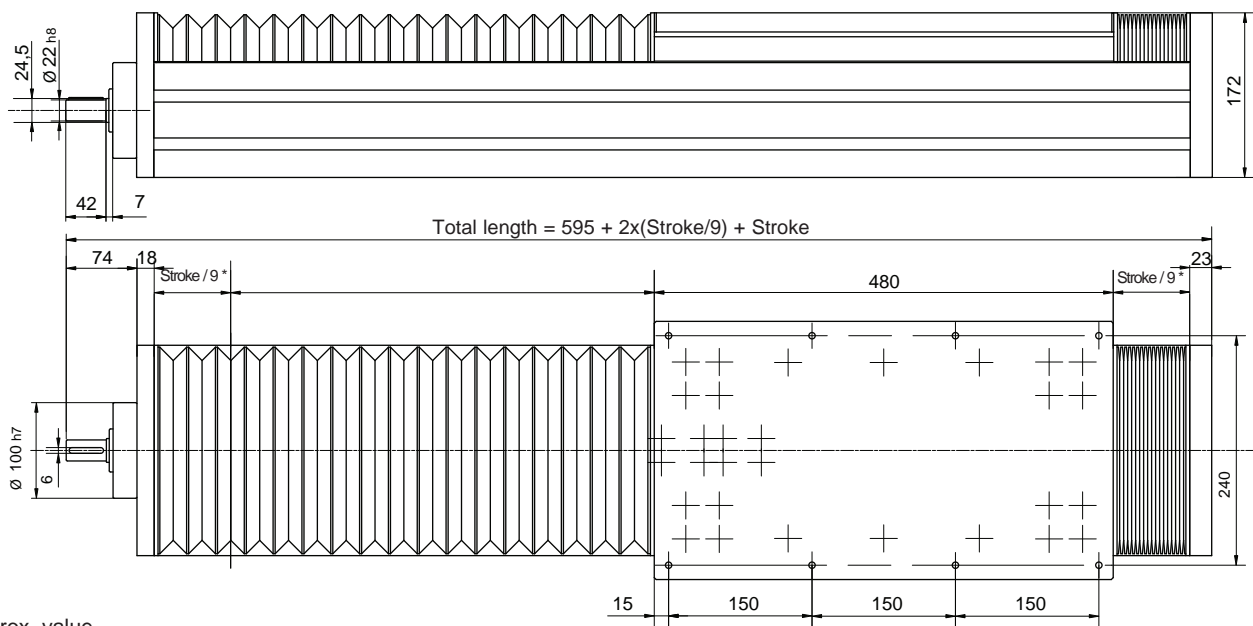

\*approx. value

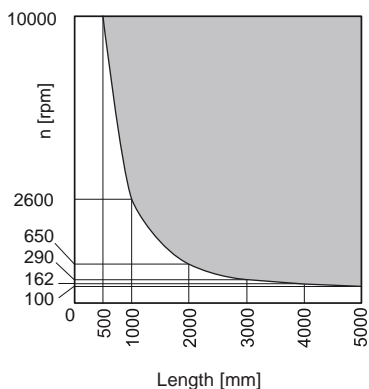

Max. stroke-speed limit over which some support bearings are required (SI) to avoid an excessive screw vibration. The working point marked inside the broken line is not recommended.

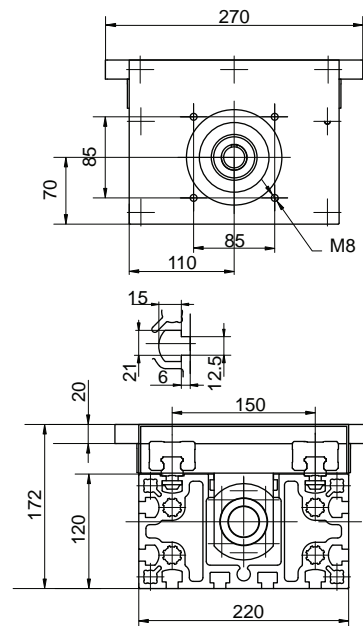

Performances		TVS 220	
Max. stroke		4,000	[mm]
Max. speed	Pitch 5 [mm]	0.15	[m/s]
	Pitch 10 [mm]	0.30	[m/s]
	Pitch 20 [mm]	0.75	[m/s]
	Pitch 32 [mm]	1.00	[m/s]

Suggested working load conditions						
Module	M <sub>x</sub> [Nm]	M <sub>y</sub> [Nm]	M <sub>z</sub> [Nm]	F <sub>x</sub> [N]	F <sub>y</sub> [N]	F <sub>z</sub> [N]
TVS 220	1,300	3,200	3,200	*6,000	18,300	18,300

The dynamic values shown do not refer to the max. theoretical load capacity. They include a safety coefficient for automated machinery. In case of peak forces acting together please ask the technical dept.

(\*) With a pitch of 10 mm

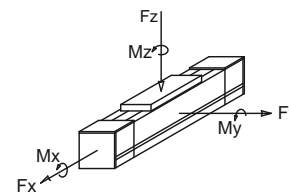

F<sub>x</sub> = Max belt strength

Data	
Slide	4 caged ball roller slides size 25
Beam	Logyca (see page ML-13)
Ø screw	32 [mm]
Bellow	heat-sealed, plastic

Weights	
Inertia of the worm	0.0006 • L. screw(m) [kgm <sup>2</sup> ]
Carriage weight	13 [kg]
Base module (stroke=0)	M <sub>base</sub> = 44 [kg]
1,000 mm profile	q = 37 [kg]

To calculate the module weight use the following formula:  $M = M_{base} + q \cdot \text{stroke}_{max} / 1,000$  Stroke<sub>max</sub> [mm]



## TCG 100

HARDENED GUIDE RAILS AND CYLINDRICAL SHAPED ROLLERS

Registered model

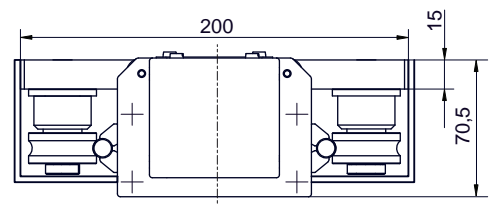
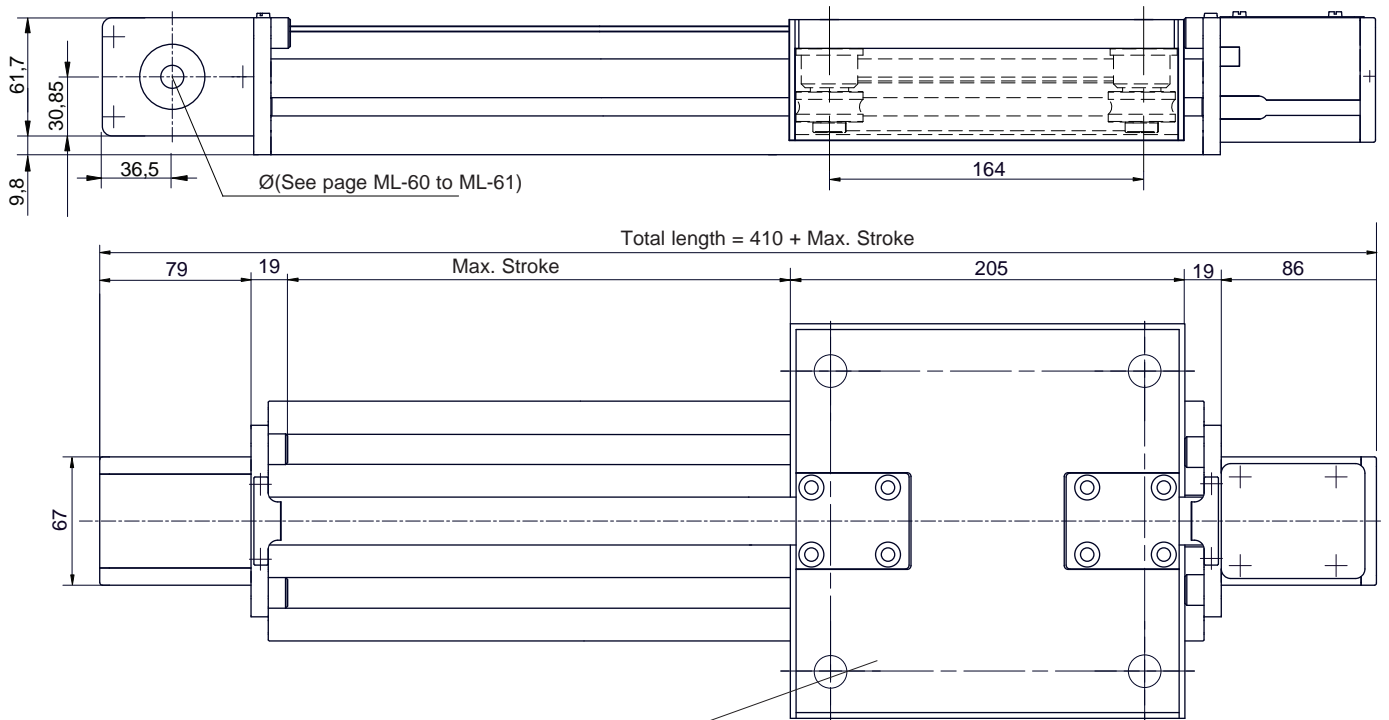

Performances	TCG 100	
Max. stroke	5,490	[mm]
Max. speed	5	[m/s]
Max. acceleration	20	[m/s <sup>2</sup> ]
Repeatability	± 0.1*	[mm]
Loadless torque	2	[Nm]

Suggested working load conditions						
Module	M <sub>x</sub> [Nm]	M <sub>y</sub> [Nm]	M <sub>z</sub> [Nm]	F <sub>x</sub> [N]	F <sub>y</sub> [N]	F <sub>z</sub> [N]
TCG 100	40	120	200	1,100	1,700	1,200

The dynamic values shown do not refer to the max. theoretical load capacity. They include a safety coefficient for automated machinery. In case of peak forces acting together please ask the technical dept

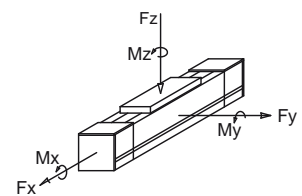

F<sub>x</sub>= Max belt strength

Assembly positions and load direction, see page ML-10

Data	
Belt	25AT5
Slide	4 shaped rollers Ø35 [mm]
Load bearing profile	MA 1-4 (see page ML-12)
Pulley Ø	50.93 [mm]
Linear displacement per revolution	160 [mm]

Weights	
Inertia of the pulley	- [kgm <sup>2</sup> ]
Belt weight	0.21 [kg/m]
Carriage weight	2.5 [kg]
Base module (stroke=0)	M <sub>base</sub> =6.4 [kg]
1,000 mm profile	q=8.3 [kg]

To calculate the module weight use the following formula:  $M = M_{base} + q \cdot stroke_{max} / 1,000$  Stroke<sub>max</sub> [mm]

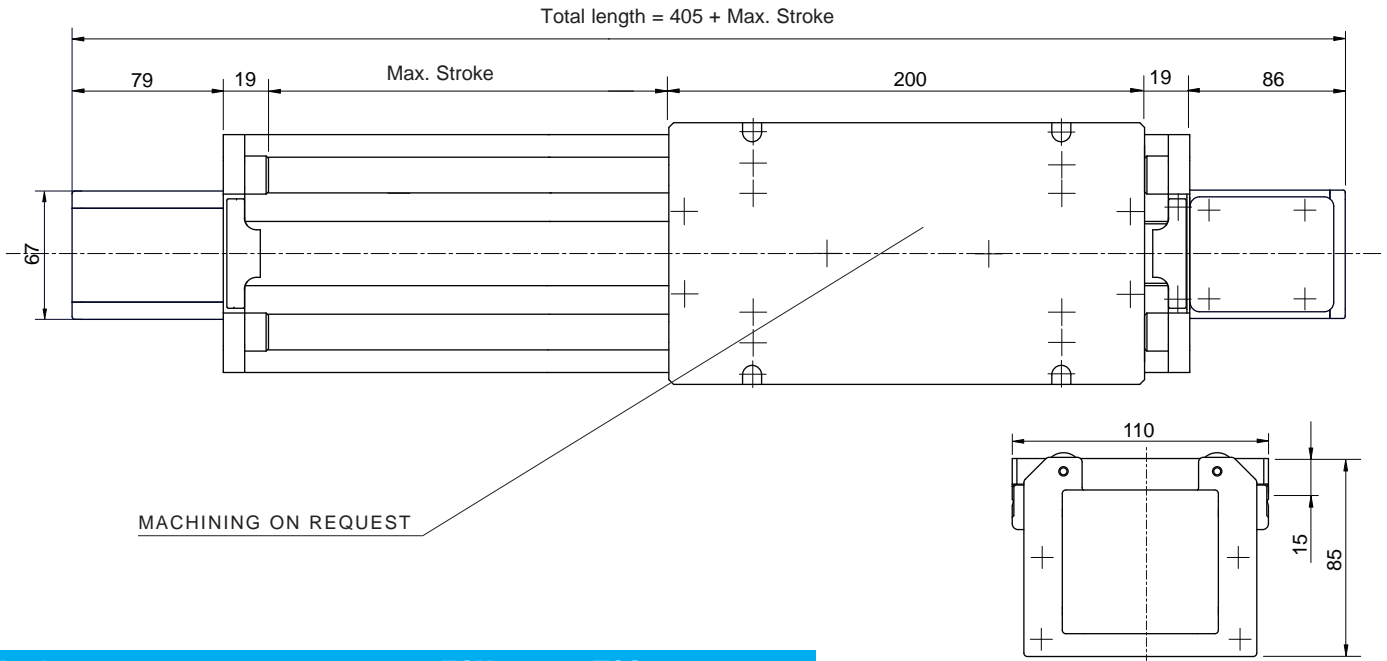
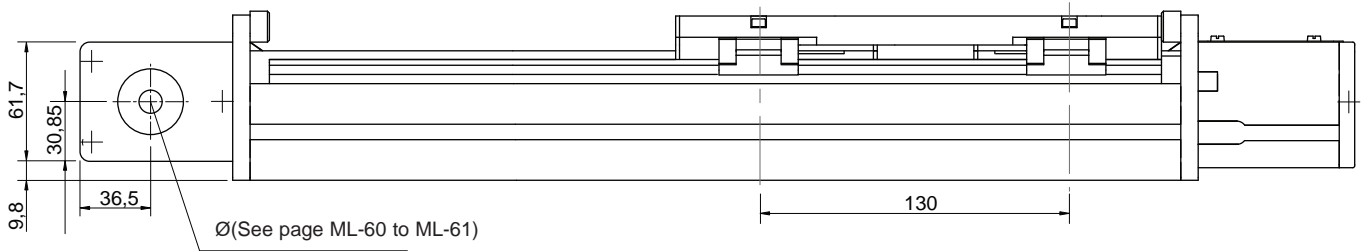

Performances	TCH 100	TCS 100	
Max. stroke	5,400	5,400	[mm]
Max. speed	5	5	[m/s]
Max. acceleration	50	50	[m/s <sup>2</sup> ]
Repeatability	± 0.1	± 0.1	[mm]
Loadless torque	-	-	[Nm]

Suggested working load conditions						
Module	M <sub>x</sub> [Nm]	M <sub>y</sub> [Nm]	M <sub>z</sub> [Nm]	F <sub>x</sub> [N]	F <sub>y</sub> [N]	F <sub>z</sub> [N]
TCH 100	138	324	324	1,180	4,100	4,100
TCS 100	150	324	324	1,180	4,100	4,100

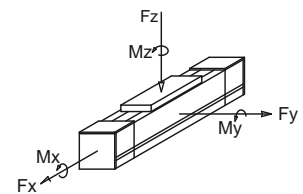

F<sub>x</sub>= Max belt strength

The dynamic values shown do not refer to the max. theoretical load capacity. They include a safety coefficient for automated machinery. In case of peak forces acting together please ask the technical dept

Data	
Belt	25AT5
Sliding	4 caged ball roller slides size15
Load bearing profile	MA 1-4 (see page ML- 12)
Pulley Ø	50.93 [mm]
Linear displacement per revolution	160 [mm]

Weights		
Inertia of the pulley	-	[kgm <sup>2</sup> ]
Belt weight	0.21	[kg/m]
Carriage weight	2.6	[kg]
Base module (stroke=0)	M <sub>base</sub> =6.5	[kg]
1,000 mm profile	q=9.2	[kg]

To calculate the module weight use the following formula:  $M = M_{base} + q \cdot stroke_{max} / 1,000$  Stroke<sub>max</sub> [mm]

# TCRQ 180 e TCG 180

WITH V-SHAPED GUIDE RAILS  
AND ROLLER SLIDES OR SHAPED ROLLERS

Modline

Registered model

Accessories: see page ML-10

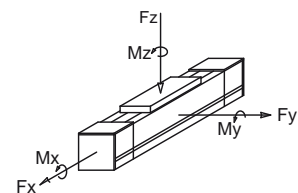
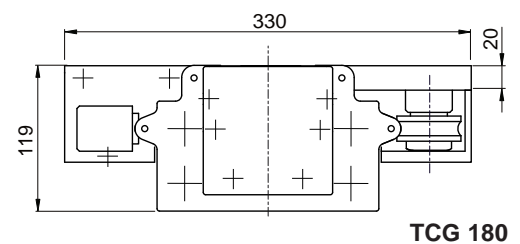
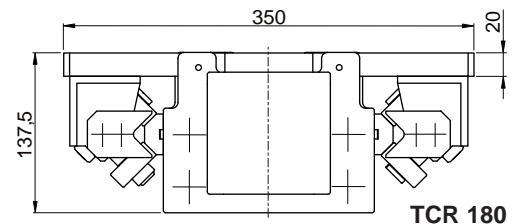
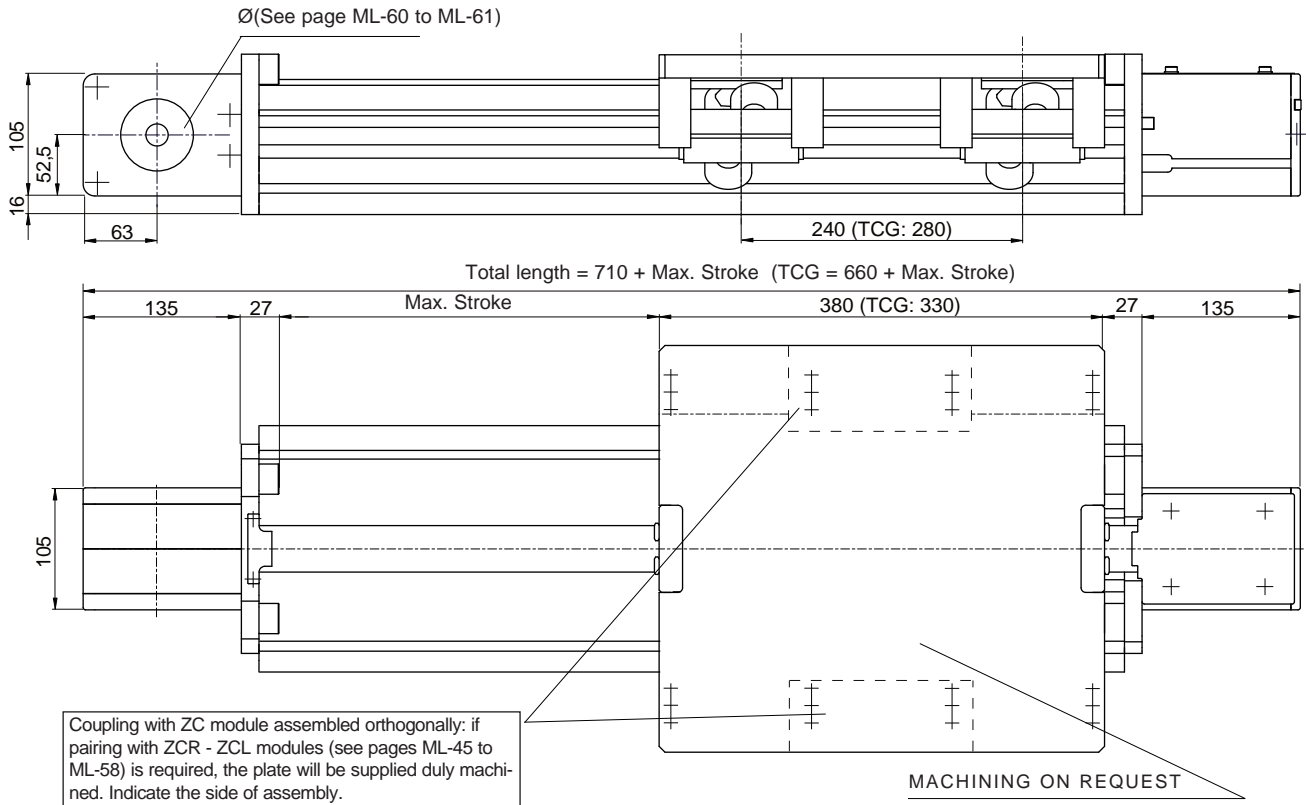

Fx= Max belt strength

Performances	TCRQ 180	TCG 180	
Max. stroke	7,480	7,540	[mm]
Max. speed	5	5	[m/s]
Max. acceleration	20	20	[m/s <sup>2</sup> ]
Repeatability	± 0.1	± 0.1	[mm]
Loadless torque	4.2	1.2	[Nm]

Suggested working load conditions						
Module	M <sub>x</sub> [Nm]	M <sub>y</sub> [Nm]	M <sub>z</sub> [Nm]	F <sub>x</sub> [N]	F <sub>y</sub> [N]	F <sub>z</sub> [N]
TCRQ 180	630	800	800	3,300	7,320	7,320
TCG 180	220	270	540	3,300	3,400	1,800

The dynamic values shown do not refer to the max. theoretical load capacity. They include a safety coefficient for automated machinery. In case of peak forces acting together please ask the technical dept

Assembly positions and load direction, see page ML-10

Data	TCRQ 180	TCG 180
Belt	40ATL10	
Slide	4 roller slides with 2 rollers 4 rollers Ø 52, guide Ø16	
Load bearing profile	E01-5 (see page ML-12)	
Pulley Ø	92.31	[mm]
Linear displacement per rev.	290	[mm]

Weights	TCRQ 180	TCG 180
Inertia of the pulley	0.0037	[kgm <sup>2</sup> ]
Belt weight	0.55	[kg/m]
Carriage weight	12.4	10.6
Base module (stroke=0)	M <sub>base</sub> =32	27.6
1,000 mm profile	q=21	q=16.8

To calculate the module weight use the following formula:  $M = M_{base} + q \cdot stroke_{max} / 1,000$  Stroke<sub>max</sub> [mm]

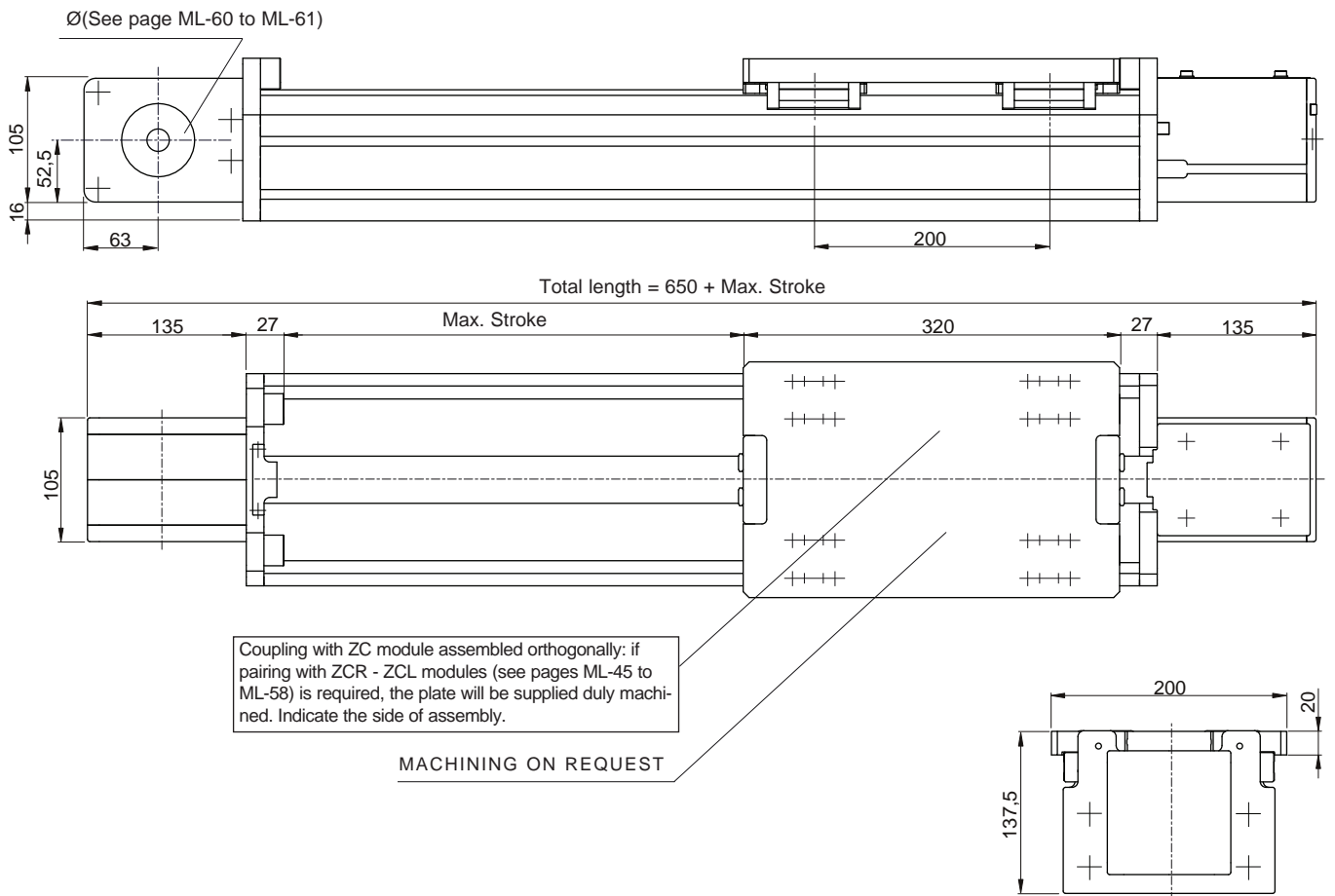

Performances	TCH 180	TCS 180	
Max. stroke	7,340	7,340	[mm]
Max. speed	5	5	[m/s]
Max. acceleration	50	50	[m/s <sup>2</sup> ]
Repeatability	± 0.1	± 0.1	[mm]
Loadless torque	3.2	3.2	[Nm]

Suggested working load conditions						
Module	M <sub>x</sub> [Nm]	M <sub>y</sub> [Nm]	M <sub>z</sub> [Nm]	F <sub>x</sub> [N]	F <sub>y</sub> [N]	F <sub>z</sub> [N]
TCH 180	600	850	850	3,300	9,200	9,200
TCS 180	960	1,350	1,350	3,300	10,950	10,950

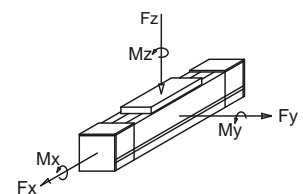

F<sub>x</sub> = Max belt strength

The dynamic values shown do not refer to the max. theoretical load capacity. They include a safety coefficient for automated machinery. In case of peak forces acting together please ask the technical dept

Data	TCH 180 - TCS 180
Belt	40ATL10
Slide	4 caged ball slides size 20
Load bearing profile	E01-5 (see page ML-12)
Pulley Ø	92.31 [mm]
Linear displacement per rev.	290 [mm]

Weights	TCH 180 - TCS 180
Inertia of the pulley	0.0037 [kgm <sup>2</sup> ]
Belt weight	0.55 [kg/m]
Carriage weight	6 [kg]
Base module (stroke=0)	M <sub>base</sub> =23.6 [kg]
1,000 mm profile	q=19 [kg]

To calculate the module weight use the following formula:  $M = M_{base} + q \cdot stroke_{max} / 1,000$  Stroke<sub>max</sub> [mm]

Registered model

Accessories: see page ML-10

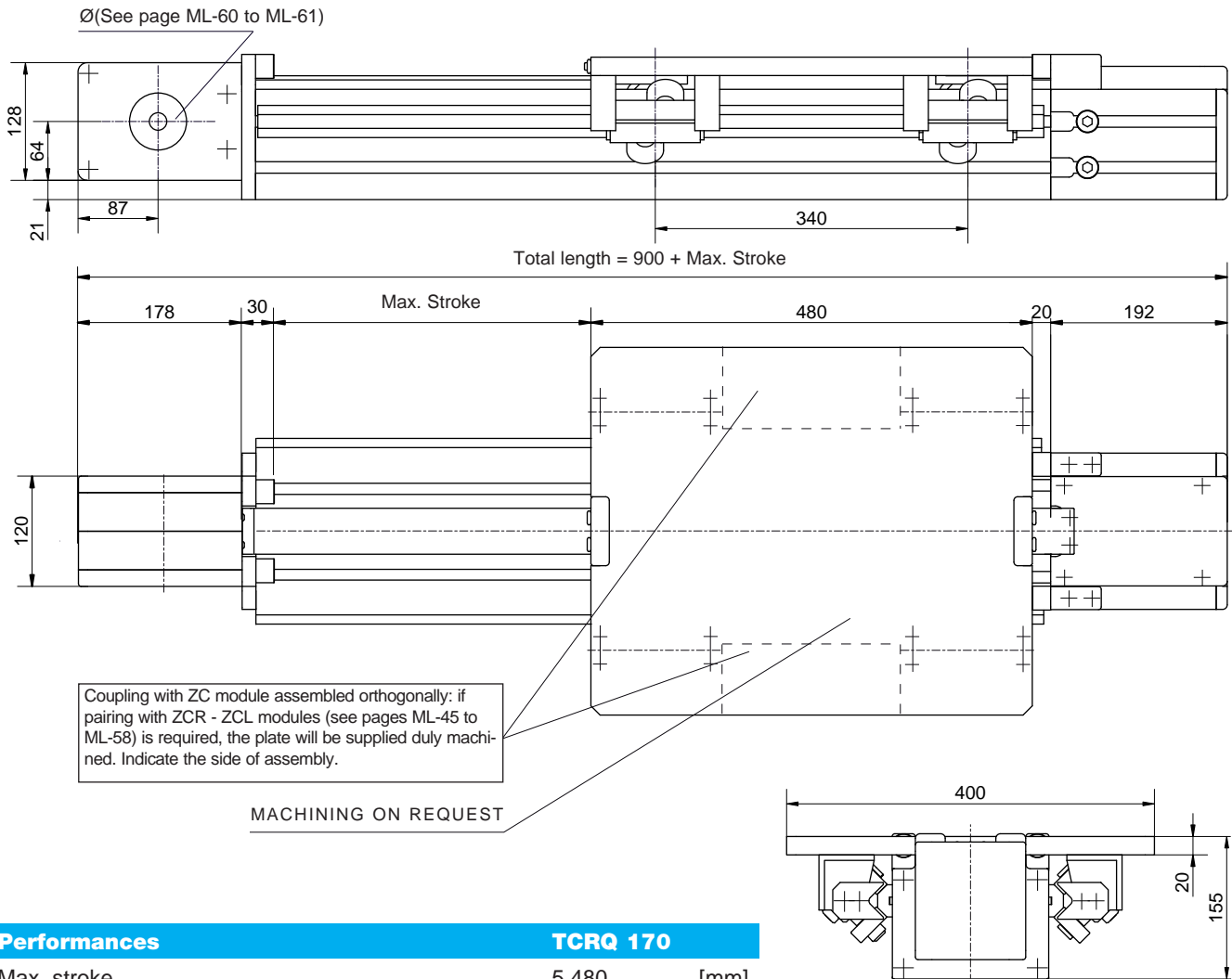

Performances	TCRQ 170	
Max. stroke	5,480	[mm]
Max. speed	7	[m/s]
Max. acceleration	20	[m/s <sup>2</sup> ]
Repeatability	± 0.1	[mm]
Loadless torque	4.2	[Nm]

Suggested working load conditions						
Module	M <sub>x</sub> [Nm]	M <sub>y</sub> [Nm]	M <sub>z</sub> [Nm]	F <sub>x</sub> [N]	F <sub>y</sub> [N]	F <sub>z</sub> [N]
TCRQ 170	590	1,202	1,202	4,000	7,070	7,070

The dynamic values shown do not refer to the max. theoretical load capacity. They include a safety coefficient for automated machinery. In case of peak forces acting together please ask the technical dept

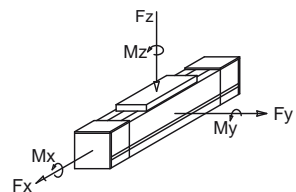

F<sub>x</sub>= Max belt strength

Assembly positions and load direction, see page ML-10

Data	
Belt	50ATL10
Slides	4 slides 2 rollers Ø40[mm]
Load bearing profile	Statyca (see page ML-13)
Pulley Ø	95.49 [mm]
Linear displacement per rev.	300 [mm]

Weights	
Inertia of the pulley	0.0053 [kgm <sup>2</sup> ]
Belt weight	0.68 [kg/m]
Carriage weight	14.6 [kg]
Base module (stroke=0)	M <sub>base</sub> =44.6 [kg]
1,000 mm profile	q=25 [kg]

To calculate the module weight use the following formula:  $M = M_{base} + q \cdot stroke_{max} / 1,000$  Stroke<sub>max</sub> [mm]

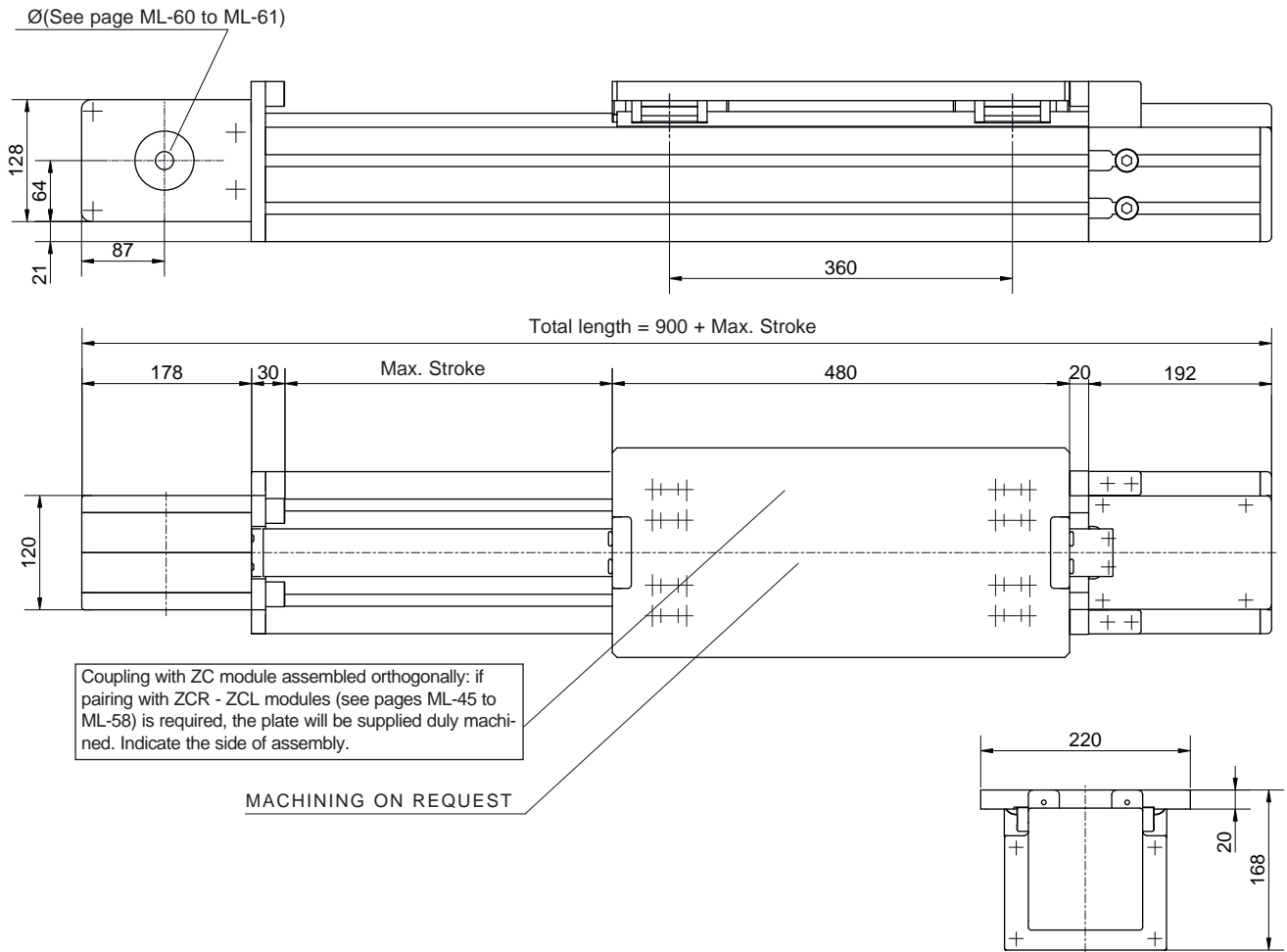

Performances	TCH 170	TCS 170	
Max. stroke	5,480	5,480	[mm]
Max. speed	5	5	[m/s]
Max. acceleration	50	50	[m/s <sup>2</sup> ]
Repeatability	± 0.1	± 0.1	[mm]
Loadless torque	4.8	4.8	[Nm]

Suggested working load conditions						
Module	M <sub>x</sub> [Nm]	M <sub>y</sub> [Nm]	M <sub>z</sub> [Nm]	F <sub>x</sub> [N]	F <sub>y</sub> [N]	F <sub>z</sub> [N]
TCH 170	450	1,430	1,430	4,000	9,400	9,400
TCS 170	720	2,050	2,050	4,000	11,950	11,950

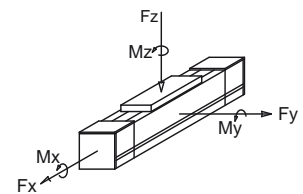

F<sub>x</sub>= Max belt strength

The dynamic values shown do not refer to the max. theoretical load capacity. They include a safety coefficient for automated machinery. In case of peak forces acting together please ask the technical dept

Data	TCH 170 - TCS 170
Belt	50ATL10
Slide	4 caged ball slides size 20
Load bearing profile	Statyca (see page ML-13)
Pulley Ø	95.49 [mm]
Linear displacement per rev.	300 [mm]

Weights	TCH 170 - TCS 170
Inertia of the pulley	0.0053 [kgm <sup>2</sup> ]
Belt weight	0.68 [kg/m]
Carriage weight	8.6 [kg]
Base module (stroke=0)	M <sub>base</sub> =38 [kg]
1,000 mm profile	q=23 [kg]

To calculate the module weight use the following formula:  $M = M_{base} + q \cdot stroke_{max} / 1,000$  Stroke<sub>max</sub> [mm]

Registered model

Accessories: see page ML-10

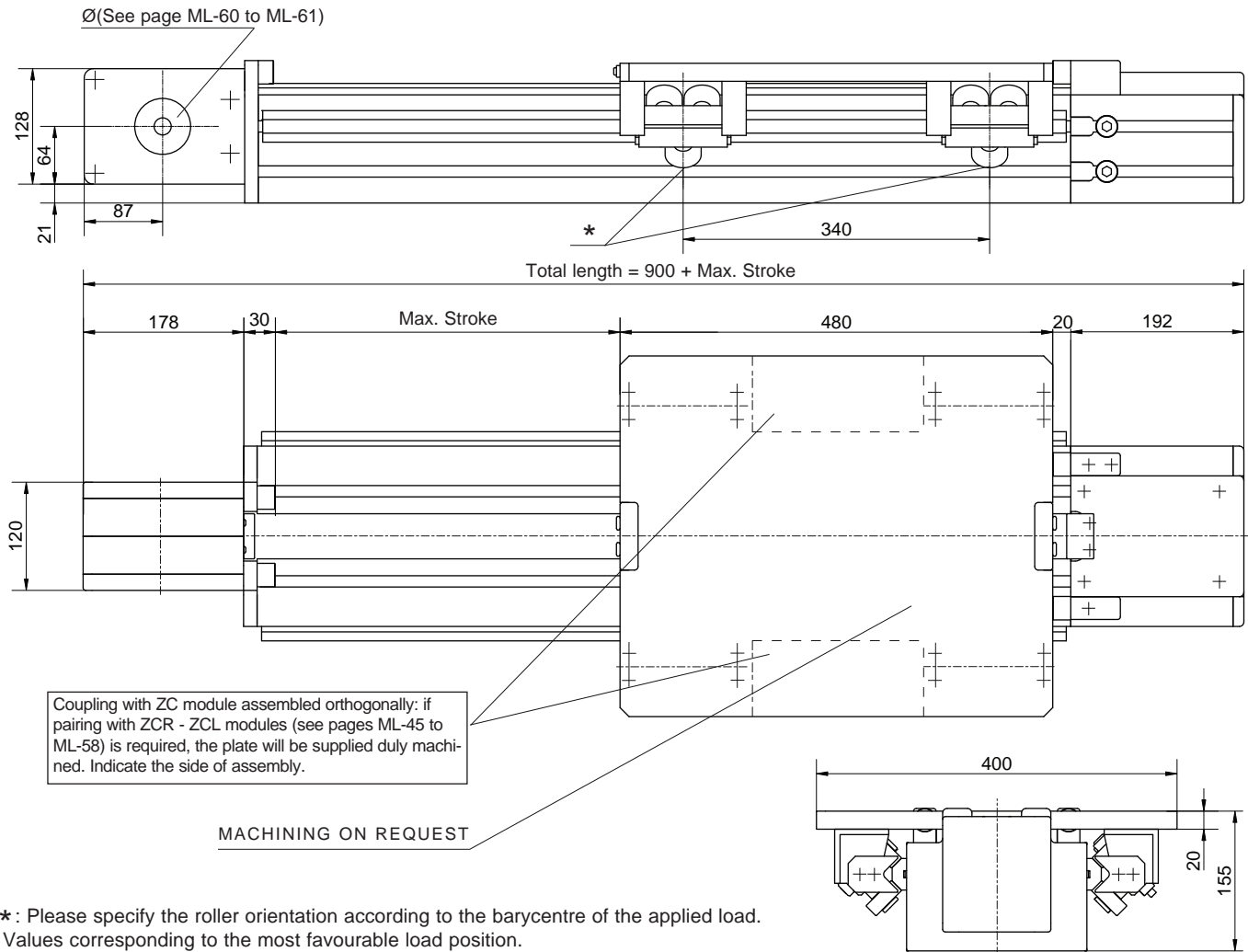

\*: Please specify the roller orientation according to the barycentre of the applied load. Values corresponding to the most favourable load position.

Performances	TCRQ 200	
Max. stroke	8,480	[mm]
Max. speed	5	[m/s]
Max. acceleration	20	[m/s <sup>2</sup> ]
Repeatability	± 0.1	[mm]
Loadless torque	4.2	[Nm]

### Suggested working load conditions

Module	M <sub>x</sub> [Nm]	M <sub>y</sub> [Nm]	M <sub>z</sub> [Nm]	F <sub>x</sub> [N]	F <sub>y</sub> [N]	F <sub>z</sub> [N]
TCRQ 200	1,300(*)	1,600(*)	1,300	4,000	7,620	12,500 (*)

The dynamic values shown do not refer to the max. theoretical load capacity. They include a safety coefficient for automated machinery. In case of peak forces acting together please ask the technical dept

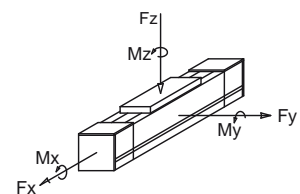

F<sub>x</sub>= Max belt strength

### Assembly positions and load direction, see page ML-10

Data	
Belt	50ATL10
Slide	4 slides 3 roll. Ø40 [mm]
Load bearing profile	Valyda (see page 13)
Pulley Ø	95.49 [mm]
Linear displacement per rev.	300 [mm]

Weights	
Inertia of the pulley	0.0053 [kgm <sup>2</sup> ]
Belt weight	0.68 [kg/m]
Carriage weight	15 [kg]
Base module (stroke=0)	M <sub>base</sub> =52 [kg]
1,000 mm profile	q=30 [kg]

To calculate the module weight use the following formula:  $M = M_{base} + q \cdot stroke_{max} / 1,000$  Stroke<sub>max</sub> [mm]

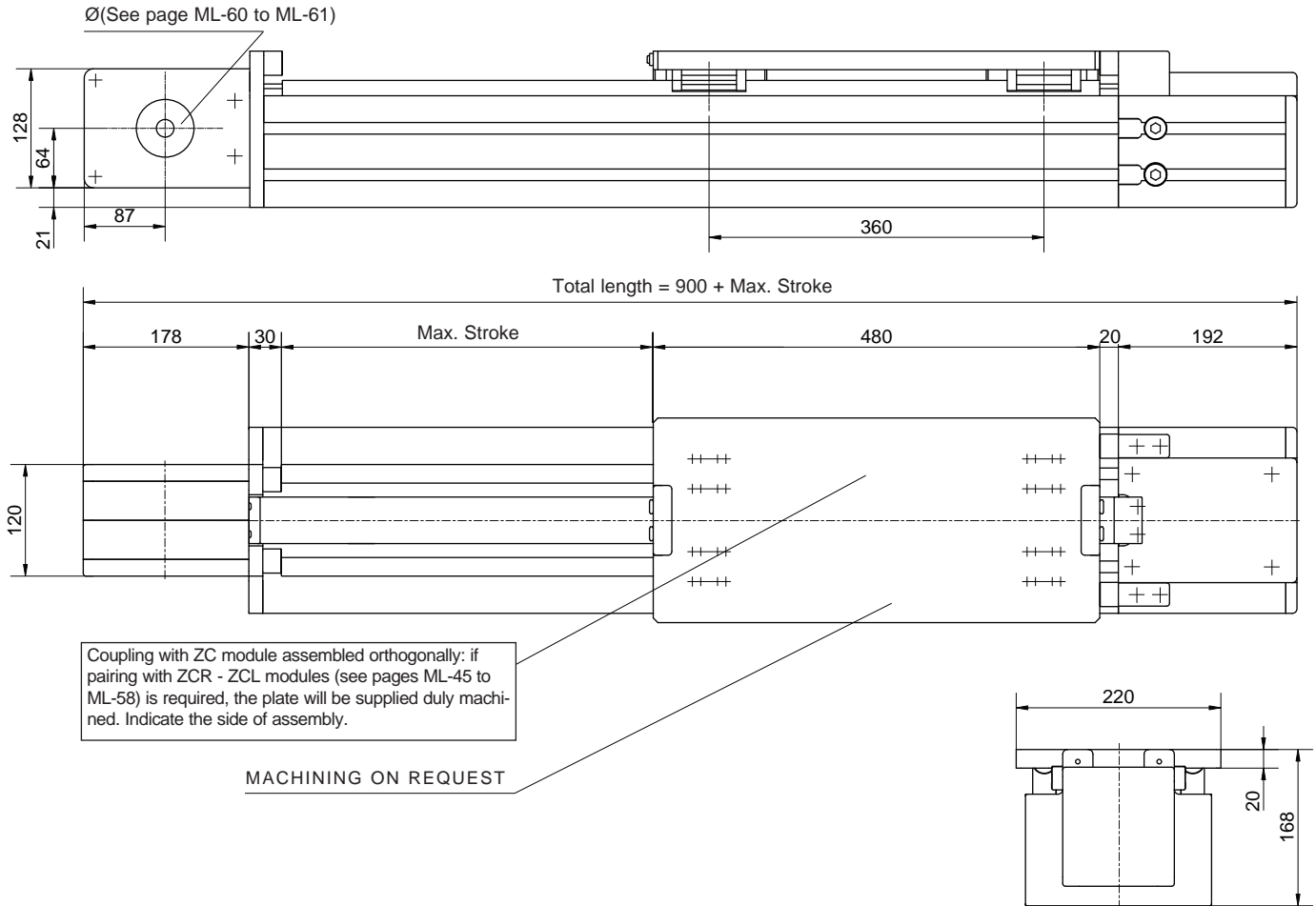

Performances	TCH 200	TCS 200	
Max. stroke	8,480	8,480	[mm]
Max. speed	5	5	[m/s]
Max. acceleration	50	50	[m/s <sup>2</sup> ]
Repeatability	± 0.1	± 0.1	[mm]
Loadless torque	4.8	4.8	[Nm]

Suggested working load conditions						
Module	M <sub>x</sub> [Nm]	M <sub>y</sub> [Nm]	M <sub>z</sub> [Nm]	F <sub>x</sub> [N]	F <sub>y</sub> [N]	F <sub>z</sub> [N]
TCH 200	500	1,430	1,430	4,000	9,400	9,400
TCS 200	810	2,050	2,050	4,000	13,950	13,950

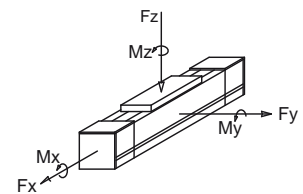

F<sub>x</sub>= Max belt strength

The dynamic values shown do not refer to the max. theoretical load capacity. They include a safety coefficient for automated machinery. In case of peak forces acting together please ask the technical dept

Data	TCH 200 - TCS 200
Belt	50ATL10
Slide	4 caged ball slides size 20
Load bearing profile	Valyda (see page ML-13)
Pulley Ø	95.49 [mm]
Linear displacement per rev.	300 [mm]

Weights	TCH 200 - TCS 200
Inertia of the pulley	0.0053 [kgm <sup>2</sup> ]
Belt weight	0.68 [kg/m]
Carriage weight	8,8 [kg]
Base module (stroke=0)	M <sub>base</sub> =42 [kg]
1,000 mm profile	q=27.5 [kg]

To calculate the module weight use the following formula:  $M = M_{base} + q \cdot stroke_{max} / 1,000$  Stroke<sub>max</sub> [mm]



Registered model

Accessories: see page ML-10

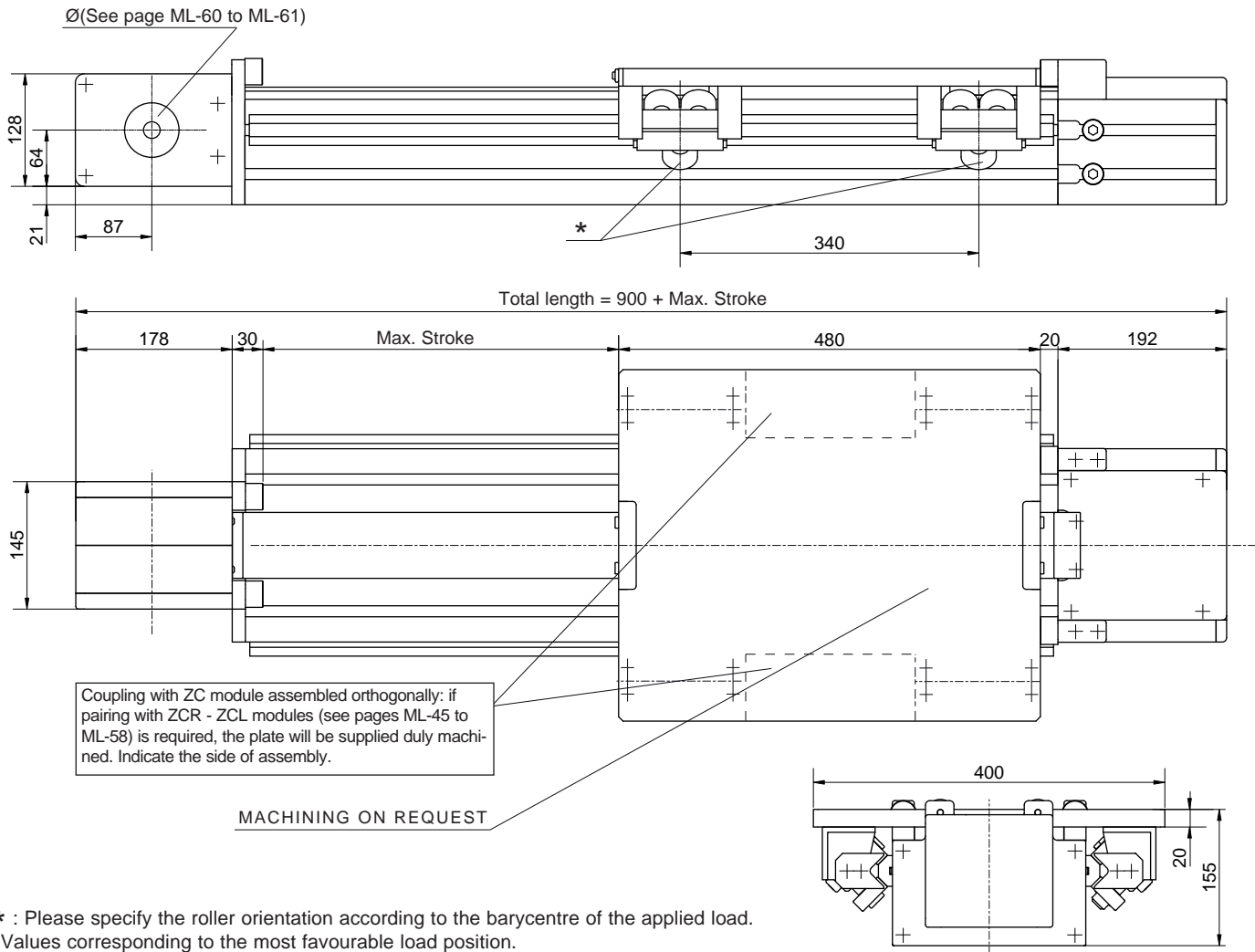

\* : Please specify the roller orientation according to the barycentre of the applied load. Values corresponding to the most favourable load position.

Performances		TCRQ 220	
Max. stroke		11,480	[mm]
Max. speed		5	[m/s]
Max. acceleration		20	[m/s <sup>2</sup> ]
Repeatability		± 0.1	[mm]
Loadless torque		5.8	[Nm]

Suggested working load conditions						
Module	M <sub>x</sub> [Nm]	M <sub>y</sub> [Nm]	M <sub>z</sub> [Nm]	F <sub>x</sub> [N]	F <sub>y</sub> [N]	F <sub>z</sub> [N]
TCRQ220	1,400(*)	1,600(*)	1,300	6,000	7,620	12,500(*)

The dynamic values shown do not refer to the max. theoretical load capacity. They include a safety coefficient for automated machinery. In case of peak forces acting together please ask the technical dept

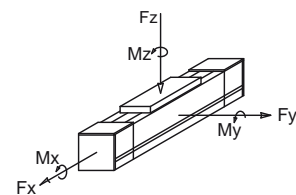

Fx= Max belt strength

Assembly positions and load direction, see page ML-10

Data	
Belt	75ATL10
Slide	4 slides 3 roll. Ø 40 [mm]
Load bearing profile	Logyca (see page ML-13)
Pulley Ø	95.49 [mm]
Linear displacement per rev.	300 [mm]

Weights	
Inertia of the pulley	0,0082 [kgm <sup>2</sup> ]
Belt weight	1,02 [kg/m]
Carriage weight	16 [kg]
Base module (stroke=0)	M <sub>base</sub> =54.6 [kg]
1,000 mm profile	q= 33.7 [kg]

To calculate the module weight use the following formula:  $M = M_{base} + q \cdot stroke_{max} / 1,000$  Stroke<sub>max</sub> [mm]

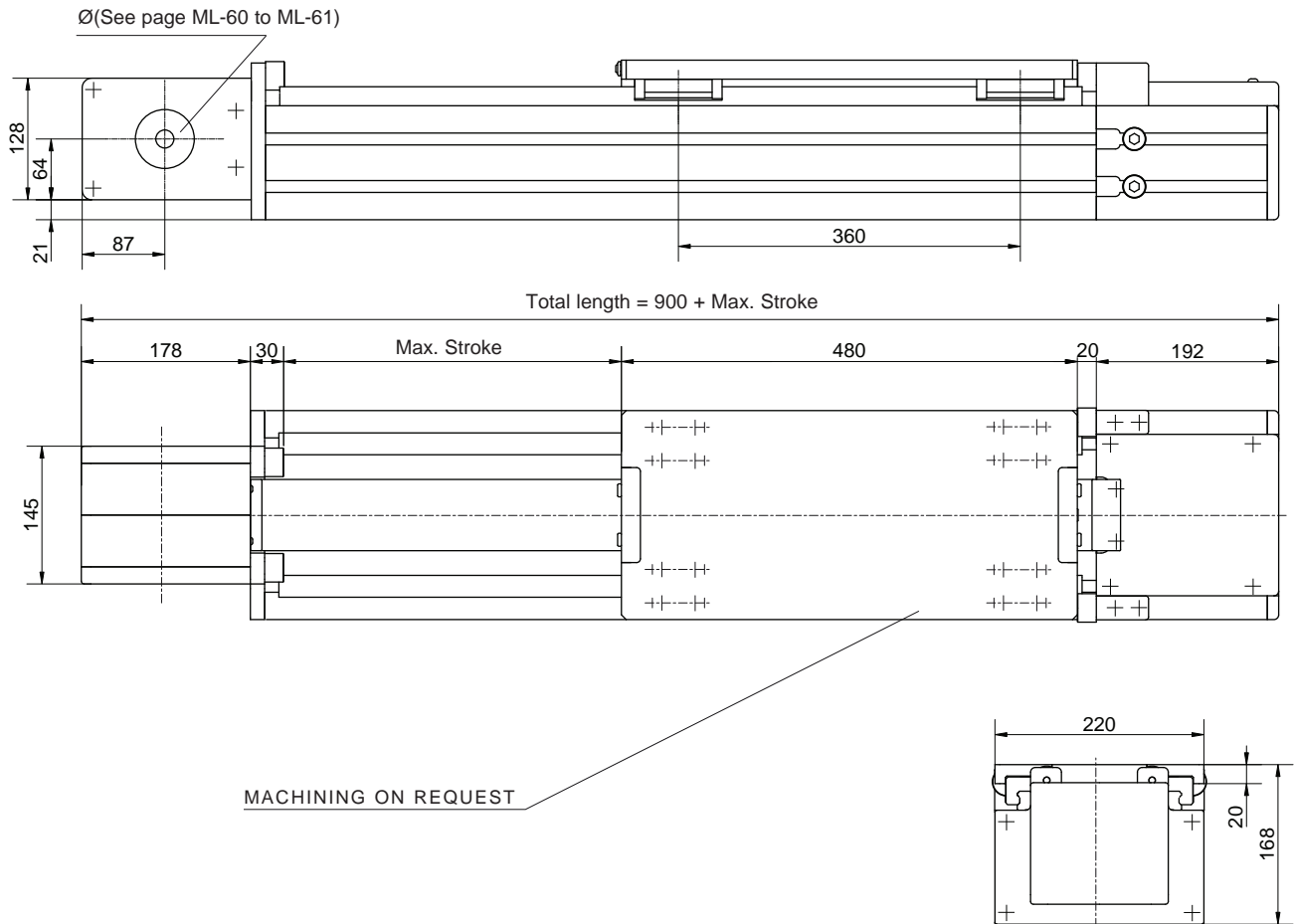

Performances	TCH 220	TCS 220	
Max. stroke	11,480	11,480	[mm]
Max. speed	5	5	[m/s]
Max. acceleration	50	50	[m/s <sup>2</sup> ]
Repeatability	± 0.1	± 0.1	[mm]
Loadless torque	6.9	6.9	[Nm]

Suggested working load conditions						
Module	M <sub>x</sub> [Nm]	M <sub>y</sub> [Nm]	M <sub>z</sub> [Nm]	F <sub>x</sub> [N]	F <sub>y</sub> [N]	F <sub>z</sub> [N]
TCH 220	950	2,200	2,200	6,000	13,000	13,000
TCS 220	1,300	3,200	3,200	6,000	18,300	18,300

The dynamic values shown do not refer to the max. theoretical load capacity. They include a safety coefficient for automated machinery. In case of peak forces acting together please ask the technical dept

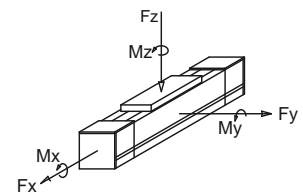

F<sub>x</sub> = Max belt strength

Data	TCH 220 - TCS 220
Belt	75ATL10
Slide	4 caged ball slides size 25
Load bearing profile	Logyca (see page ML-13)
Pulley Ø	95.49 [mm]
Linear displacement per rev.	300 [mm]

Weights	TCH 220 - TCS 220
Inertia of the pulley	0.0082 [kgm <sup>2</sup> ]
Belt weight	1.02 [kg/m]
Carriage weight	9.5 [kg]
Base module (stroke=0)	M <sub>base</sub> =47.4 [kg]
1,000 mm profile	q=33 [kg]

To calculate the module weight use the following formula:  $M = M_{base} + q \cdot stroke_{max} / 1,000$  Stroke<sub>max</sub> [mm]

# TCRQ 280 (TCRP 280)

V-SHAPED GUIDE RAILS WITH ROLLER SLIDES

Modline

Registered model\*

RP= Heavy guide rails and roller slides - Ø52

Accessories: see page ML-10

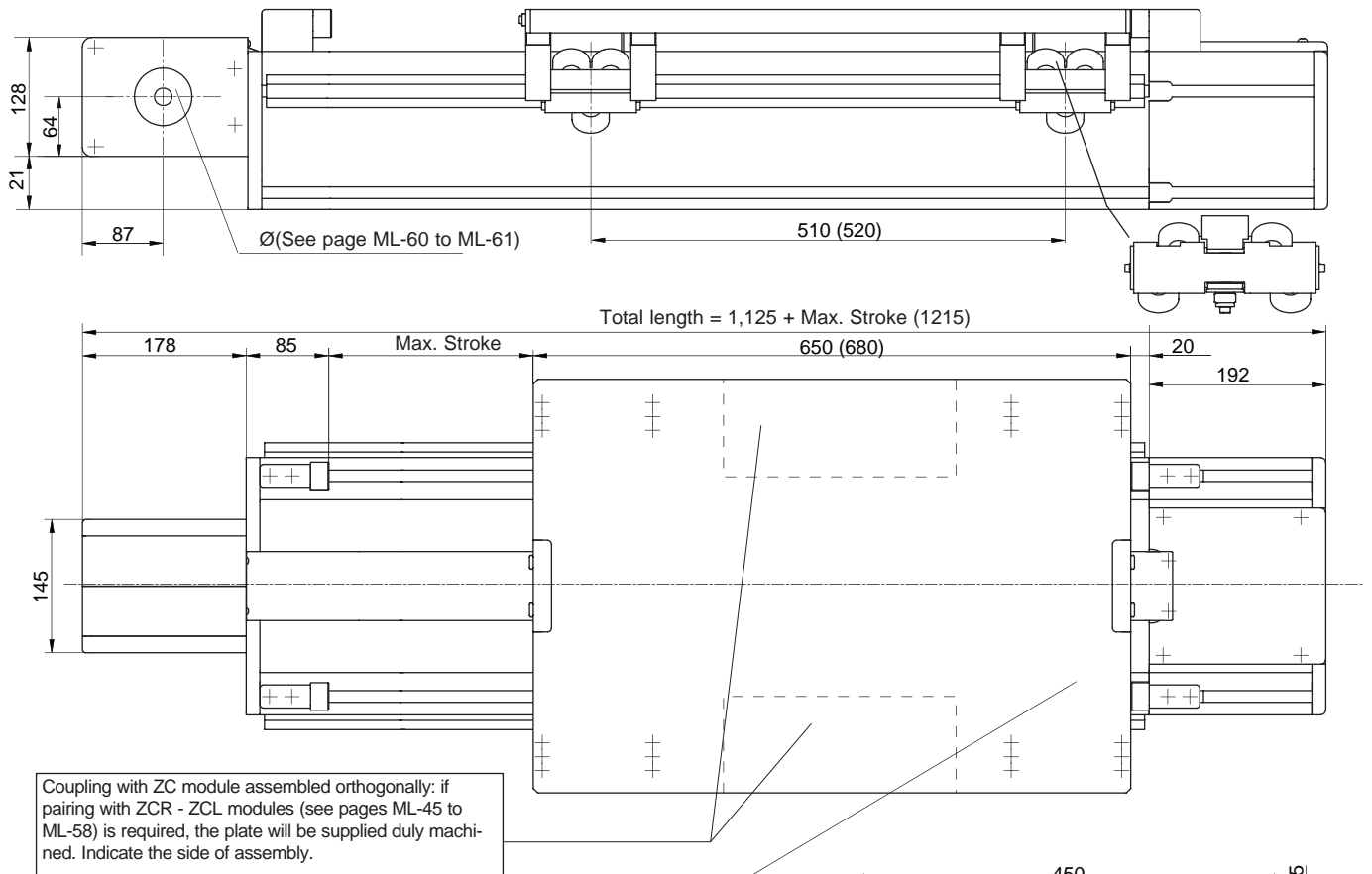

MACHINING ON REQUEST

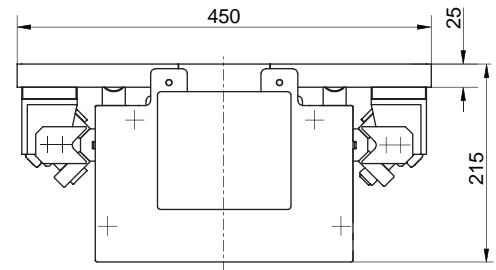

\*: Please specify the roller orientation according to the barycentre of the applied load. Values corresponding to the most favourable load position.

Performances	TCRQ 280 (TCRP280)		
Max. stroke	11,315	11,175	[mm]
Max. speed	7	5	[m/s]
Max. acceleration	20	10	[m/s <sup>2</sup> ]
Repeatability	± 0.1	± 0.1	[mm]
Loadless torque	7.6	8.5	[Nm]

### Suggested working load conditions

Module	M <sub>x</sub> [Nm]	M <sub>y</sub> [Nm]	M <sub>z</sub> [Nm]	F <sub>x</sub> [N]	F <sub>y</sub> [N]	F <sub>z</sub> [N]
TCRQ 280	1,950(*)	3,100(*)	1,950	6,000	7,620	13,500(*)
TCRP 280	3,100	4,150	4,150	6,000	20,100	20,100

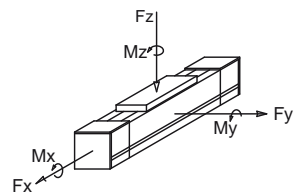

F<sub>x</sub>= Max belt strength

The dynamic values shown do not refer to the max. theoretical load capacity. They include a safety coefficient for automated machinery. In case of peak forces acting together please ask the technical dept. Versions with a 100 mm belt are also available. (TCRE/TCREP)

Assembly positions and load direction, see page ML-10

Data	TCRQ 280 (TCRP 280)	
Belt	75 ATL 10	
Slide	4 slides 3 rollers Ø40 4 slides 4 rollers Ø52 [mm]	
Load bearing profile	Pratyca (see page ML-14)	
Pulley Ø	95.49 [mm]	
Linear displacement per rev.	300 [mm]	

Weights	TCRQ 280 (TCRP 280)	
Inertia of the pulley	0.0082 [kgm <sup>2</sup> ]	
Belt weight	1.02 [kg/m]	
Carriage weight	27	55 [kg]
Base module	M <sub>base</sub> =87	M <sub>base</sub> =122 [kg]
1,000 mm profile	q=48	q=56 [kg]

To calculate the module weight use the following formula:  $M = M_{base} + q \cdot stroke_{max} / 1,000$  Stroke<sub>max</sub> [mm]

# TCH 280 - TCS 280

Registered model

Accessories: see page ML-10

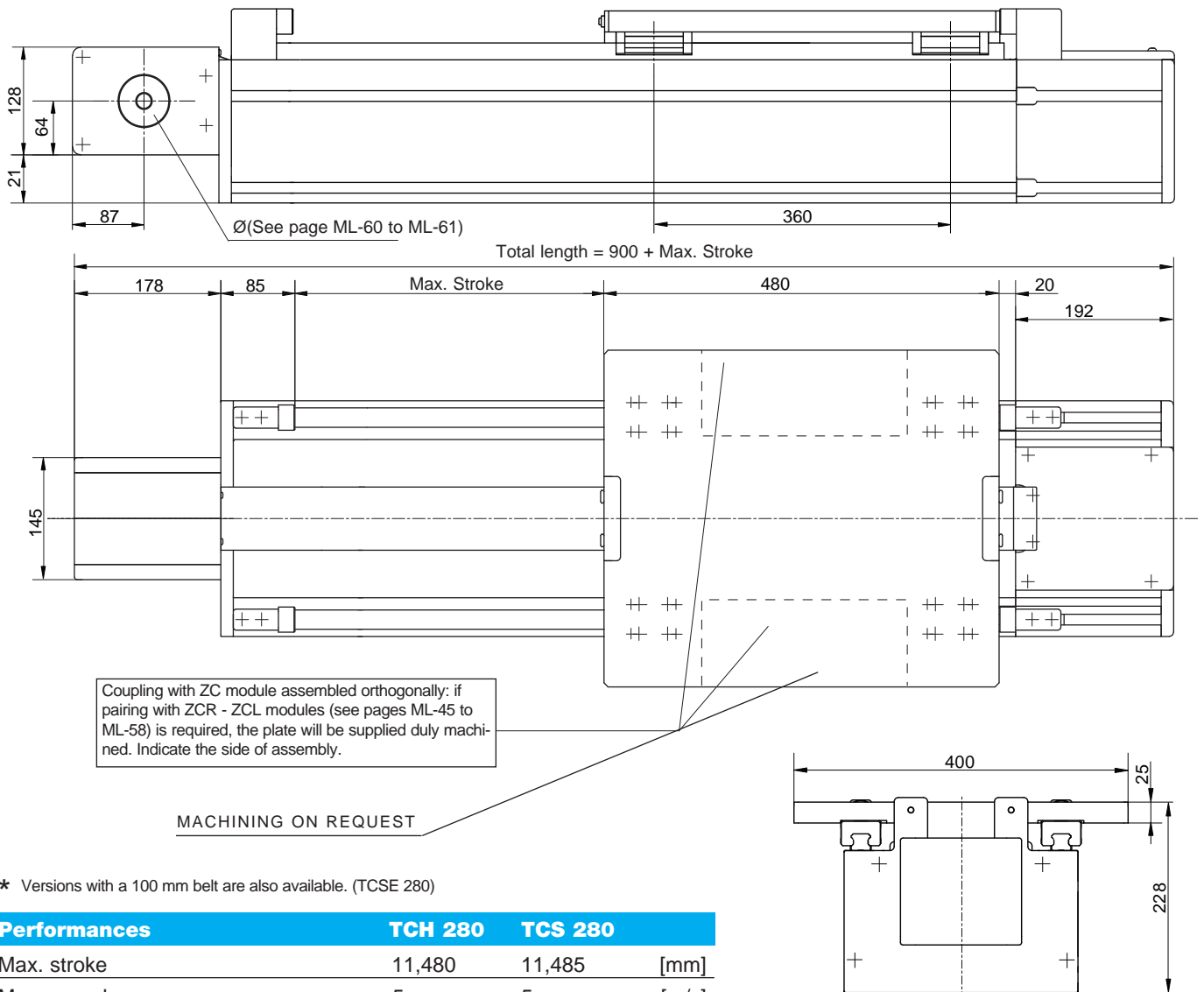

\* Versions with a 100 mm belt are also available. (TCSE 280)

Performances	TCH 280	TCS 280	
Max. stroke	11,480	11,485	[mm]
Max. speed	5	5	[m/s]
Max. acceleration	50	50	[m/s <sup>2</sup> ]
Repeatability	± 0.1	± 0.1	[mm]
Loadless torque	8.3	8.3	[Nm]

Suggested working load conditions						
Module	M <sub>x</sub> [Nm]	M <sub>y</sub> [Nm]	M <sub>z</sub> [Nm]	F <sub>x</sub> [N]	F <sub>y</sub> [N]	F <sub>z</sub> [N]
TCH 280	1,450	2,200	2,200	6,000	13,500	13,500
TCS 280	1,950	3,200	3,200	6,000	20,300	20,300

The dynamic values shown do not refer to the max. theoretical load capacity. They include a safety coefficient for automated machinery. In case of peak forces acting together please ask the technical dept

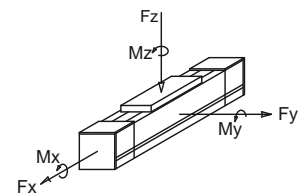

F<sub>x</sub>= Max belt strength

Data	TCH 280 - TCS 280
Belt	75 ATL 10
Slide	4 caged ball slides size 25
Load bearing profile	Pratyca (see page ML-14)
Pulley Ø	95.49 [mm]
Linear displacement per rev.	300 [mm]

Weights	TCH 280 - TCS 280
Inertia of the pulley	0.0082 [kgm <sup>2</sup> ]
Belt weight	1.02 [kg/m]
Carriage weight	18 [kg]
Base module (stroke=0)	M <sub>base</sub> =69 [kg]
1,000 mm profile	q= 47 [kg]

To calculate the module weight use the following formula:  $M = M_{base} + q \cdot stroke_{max} / 1,000$  Stroke<sub>max</sub> [mm]

Registered model

RP= Heavy guide rails and roller slides - Ø52  
Accessories: see page ML-10

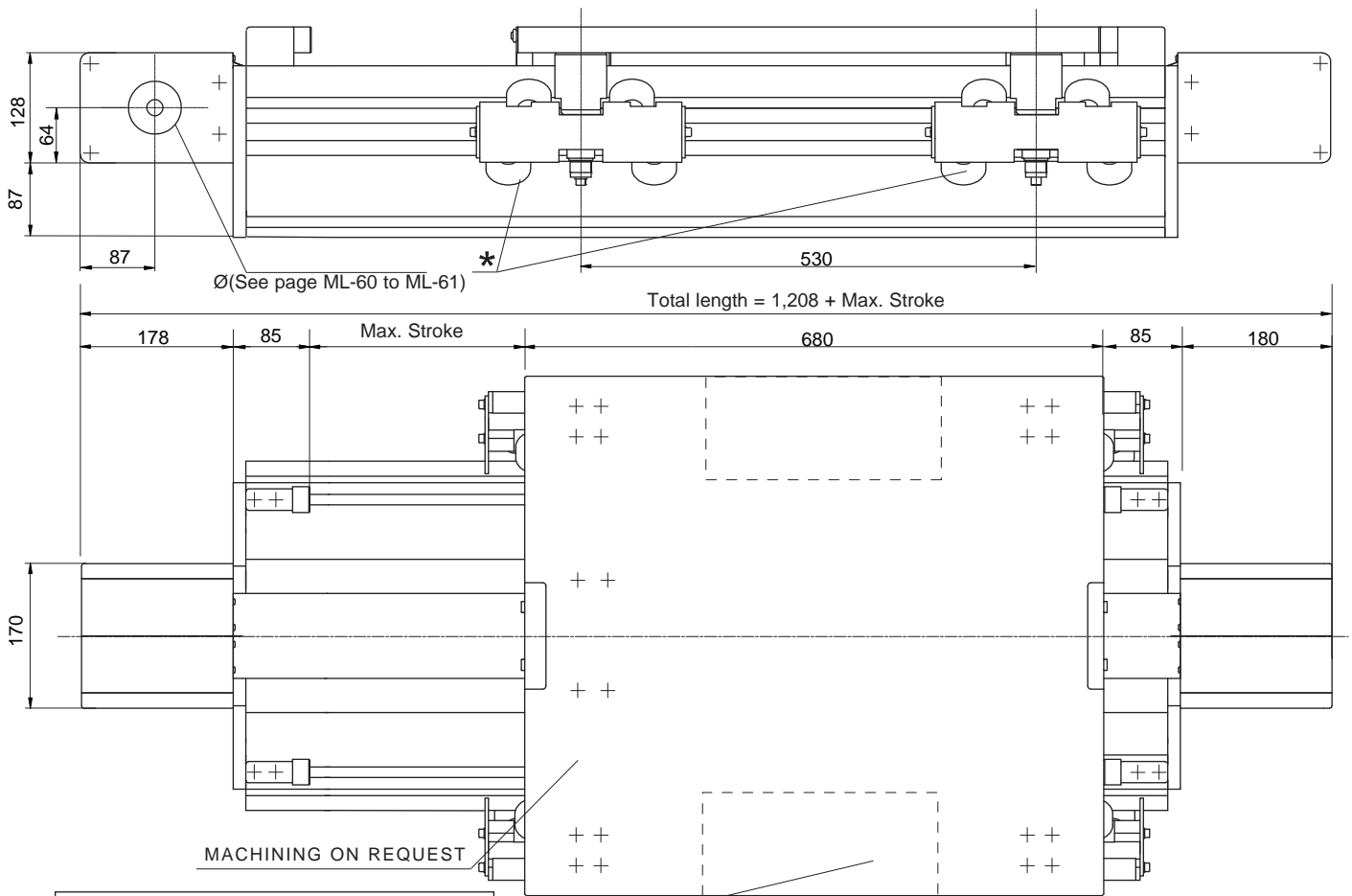

Coupling with ZC module assembled orthogonally: if pairing with ZCR - ZCL modules (see pages 42 to 53) is required, the plate will be supplied duly machined. Indicate the side of assembly.

\* Versions with a 150 mm belt are also available. (TCRPE360)

Performances	TCRP 360	
Max. stroke	11,175	[mm]
Max. speed	5	[m/s]
Max. acceleration	10	[m/s <sup>2</sup> ]
Repeatability	± 0.1	[mm]
Loadless torque	8.5	[Nm]

Suggested working load conditions						
Module	M <sub>x</sub> [Nm]	M <sub>y</sub> [Nm]	M <sub>z</sub> [Nm]	F <sub>x</sub> [N]	F <sub>y</sub> [N]	F <sub>z</sub> [N]
TCRP 360	4,900	5,300	5,300	8,000	25,400	25,400

The dynamic values shown do not refer to the max. theoretical load capacity. They include a safety coefficient for automated machinery. In case of peak forces acting together please ask the technical dept

Assembly positions and load direction, see page ML-10

Data	
Belt	100 ATL 10
Slide	4 slides 4 rollers Ø52 [mm]
Load bearing profile	Solyda (see page ML-14)
Pulley Ø	95.49 [mm]
Linear displacement per rev.	300 [mm]

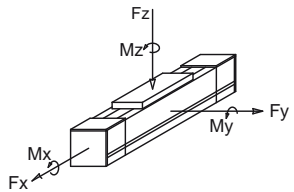
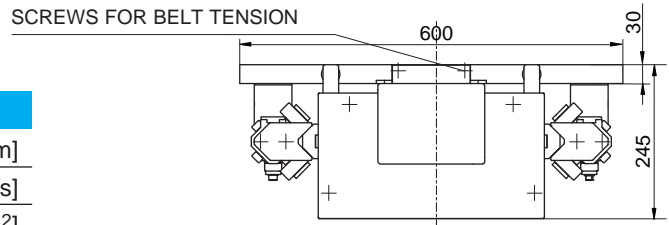

F<sub>x</sub>= Max belt strength

Weights	
Inertia of the pulley	0.0082 [kgm <sup>2</sup> ]
Belt weight	1.02 [kg/m]
Carriage weight	55 [kg]
Base module (stroke=0)	M <sub>base</sub> =137 [kg]
1,000 mm profile	q=75 [kg]

To calculate the module weight use the following formula:  $M = M_{base} + q \cdot stroke_{max} / 1,000$  Stroke<sub>max</sub> [mm]

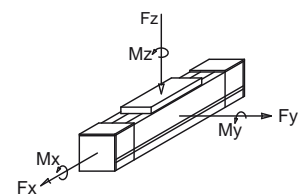
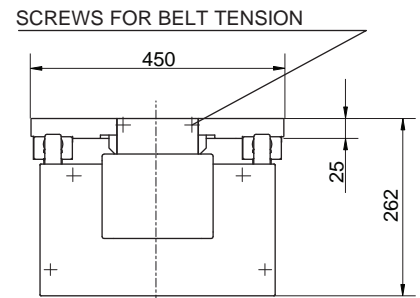
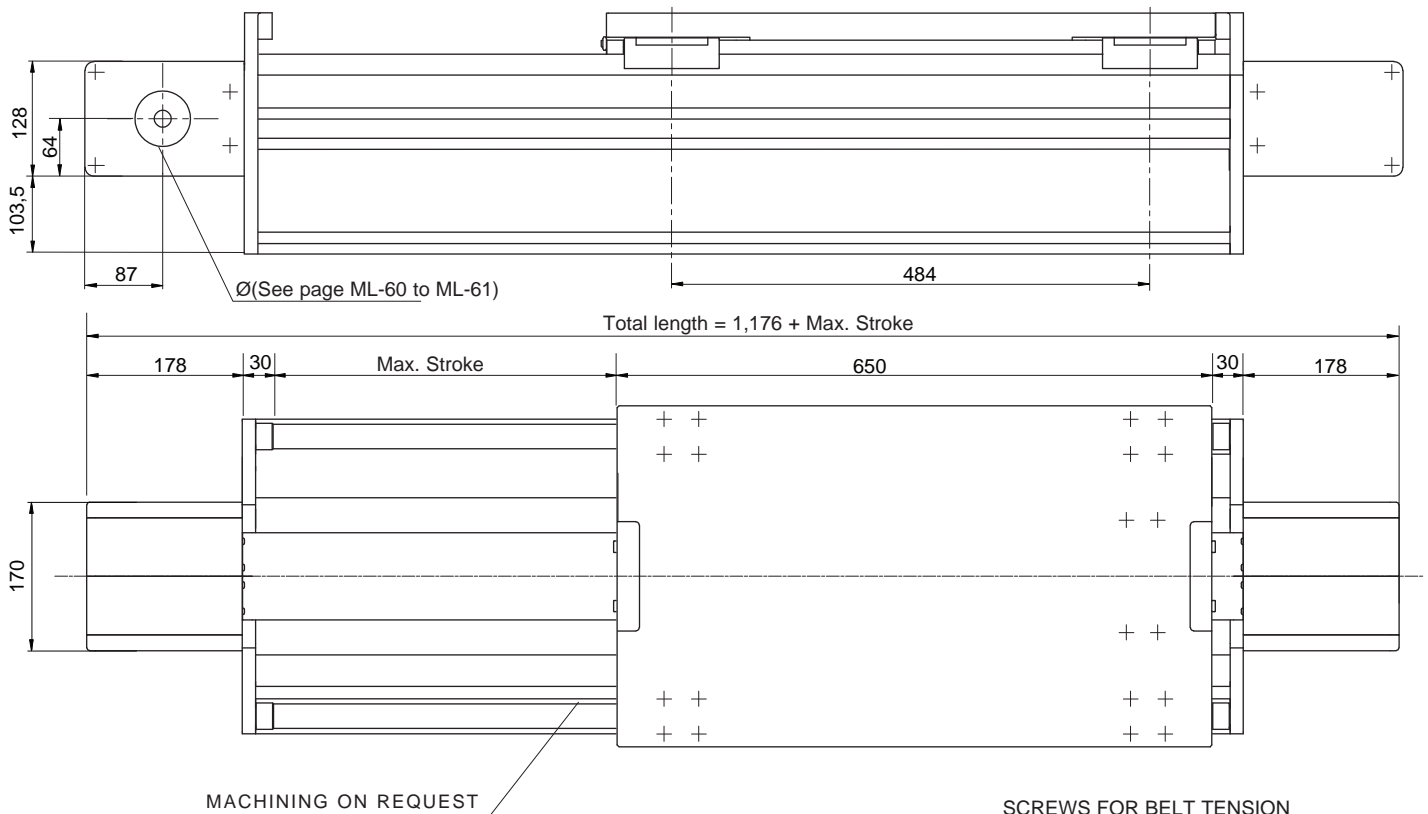

Fx= Max belt strength

\* Versions with a 150 mm belt are also available. (TCSE360)

Performances	TCH 360	TCS 360	
Max. stroke	11,480	11,485	[mm]
Max. speed	5	5	[m/s]
Max. acceleration	50	50	[m/s <sup>2</sup> ]
Repeatability	± 0.1	± 0.1	[mm]
Loadless torque	8.3	8.3	[Nm]

### Suggested working load conditions

Module	M <sub>x</sub> [Nm]	M <sub>y</sub> [Nm]	M <sub>z</sub> [Nm]	F <sub>x</sub> [N]	F <sub>y</sub> [N]	F <sub>z</sub> [N]
TCH 360	2,600	3,710	3,710	8,000	19,050	19,050
TCS 360	4,000	5,500	5,500	8,000	28,600	28,600

The dynamic values shown do not refer to the max. theoretical load capacity. They include a safety coefficient for automated machinery. In case of peak forces acting together please ask the technical dept

Data	TCH 360 - TCS 360
Belt	100 ATL 10
Slide	4 caged ball roller slides 30
Load bearing profile	Solyda (see page ML-14)
Pulley Ø	95.49 [mm]
Linear displacement per rev.	300 [mm]

Weights	TCH 360 - TCS 360
Inertia of the pulley	0.0082 [kgm <sup>2</sup> ]
Belt weight	1.02 [kg/m]
Carriage weight	28 [kg]
Base module (stroke=0)	M <sub>base</sub> =105 [kg]
1,000 mm profile	q= 70 [kg]

To calculate the module weight use the following formula:  $M = M_{base} + q \cdot \text{stroke}_{max} / 1,000$  Stroke<sub>max</sub> [mm]

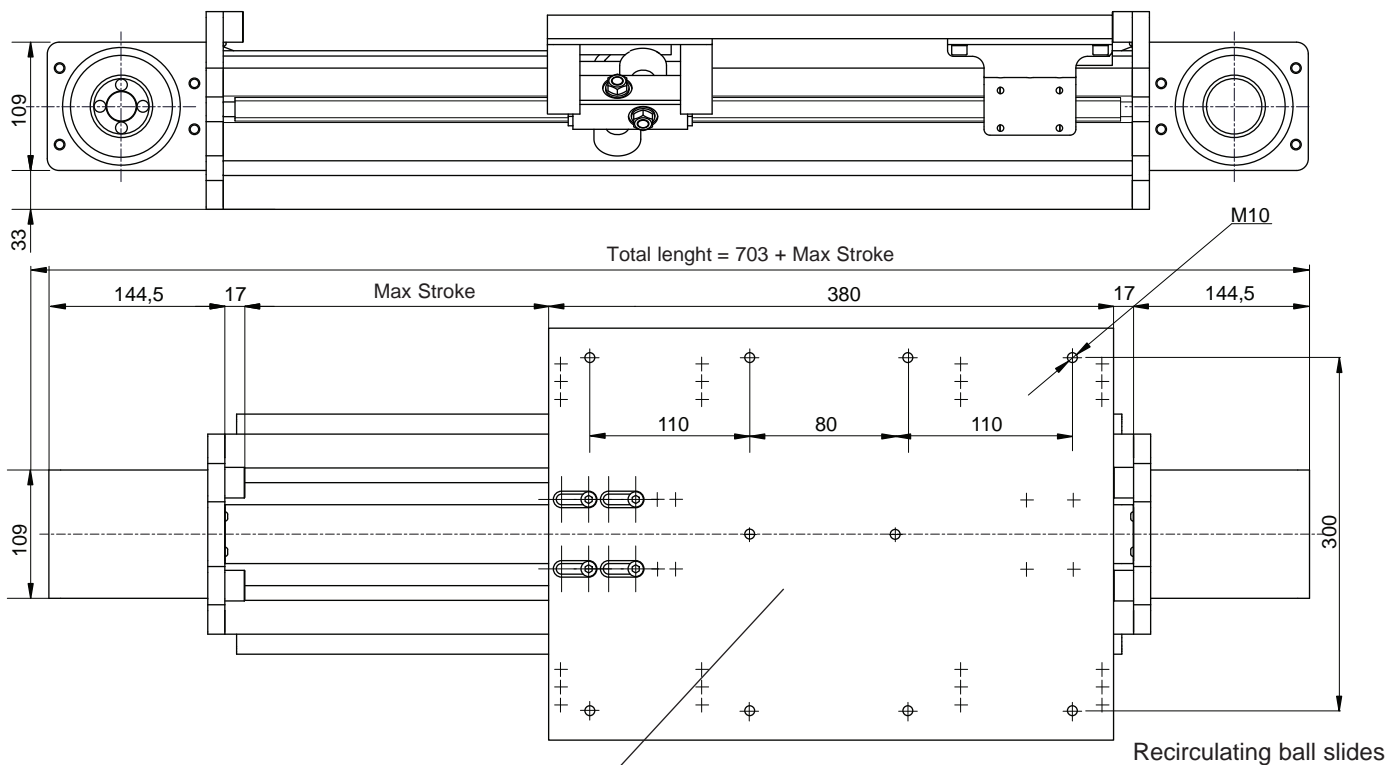

Coupling with ZC type module assembled at right angles: in the case of ZCR-ZCL unit assembly (see from pg. ML-45 to ML-58 of the Modline manual) the plate will be provided with notches and holes. Indicate the assembly side.

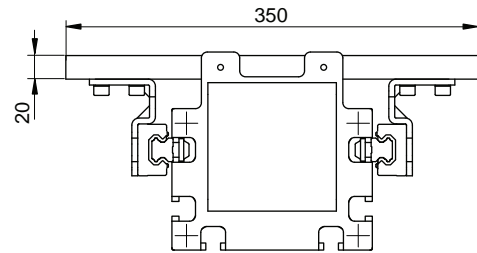

Recirculating ball slides

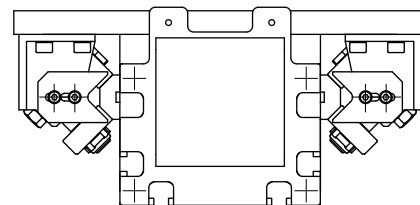

Roller slides

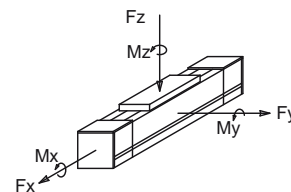

$F_x$  = Max belt strenght

Performances	TECR 170	TECH 170	
Max stroke	5.560	5.560	[mm]
Max speed	5	4	[m/s]
Max acceleration	15	20	[m/s <sup>2</sup> ]
Repositioning accuracy	± 0.1	± 0.1	[mm]
Loadless torque	4.2	4.8	[Nm]

Suggested working load conditions						
Module	$M_x$ [Nm]	$M_y$ [Nm]	$M_z$ [Nm]	$F_x$ [N]	$F_y$ [N]	$F_z$ [N]
TECR 170	590	848	848	4.000	7.070	7.070
TECH 170	580	900	1.050	4.000	7.620	7.620

The dynamic values indicated do not correspond to maximum theoretical load capacities. They already take safety factors into account which are suitable for machinery in the automation sector. In the event of combined stress consult the technical support service.

Constructive data	TECR 170 - TECH 170
Belt	50 ATL 10
Sliding (TECR170)	4 roller slides [mm]
Sliding (TECH 170)	4 ball slides size 20 [mm]
Profile	Statyca (see page ML-13)
Pulley Ø	95,49 [mm]
Linear displacement per revolution	300 [mm]

Weight	TECH 170 - TECR 170
Inertia of the pulley	0,0053 [kgm <sup>2</sup> ]
Belt weight	0,68 [kg/m]
Carriage weight	8,6 [kg]
Base module (corsa=0)	$M_{base} = 38$ [kg]
1.000 mm profile	$q = 23$ [kg]

To calculate the module weight use the following formula:  $M = M_{base} + q \cdot \text{Stroke}_{max} / 1.000 \text{ Stroke}_{max} [\text{mm}]$

# TECRR 180 - TECH 180 (EASY)

TRAPEZOIDAL GUIDES AND ROLLER SLIDES OR RECIRCULATING BALL SLIDES

Patent pending

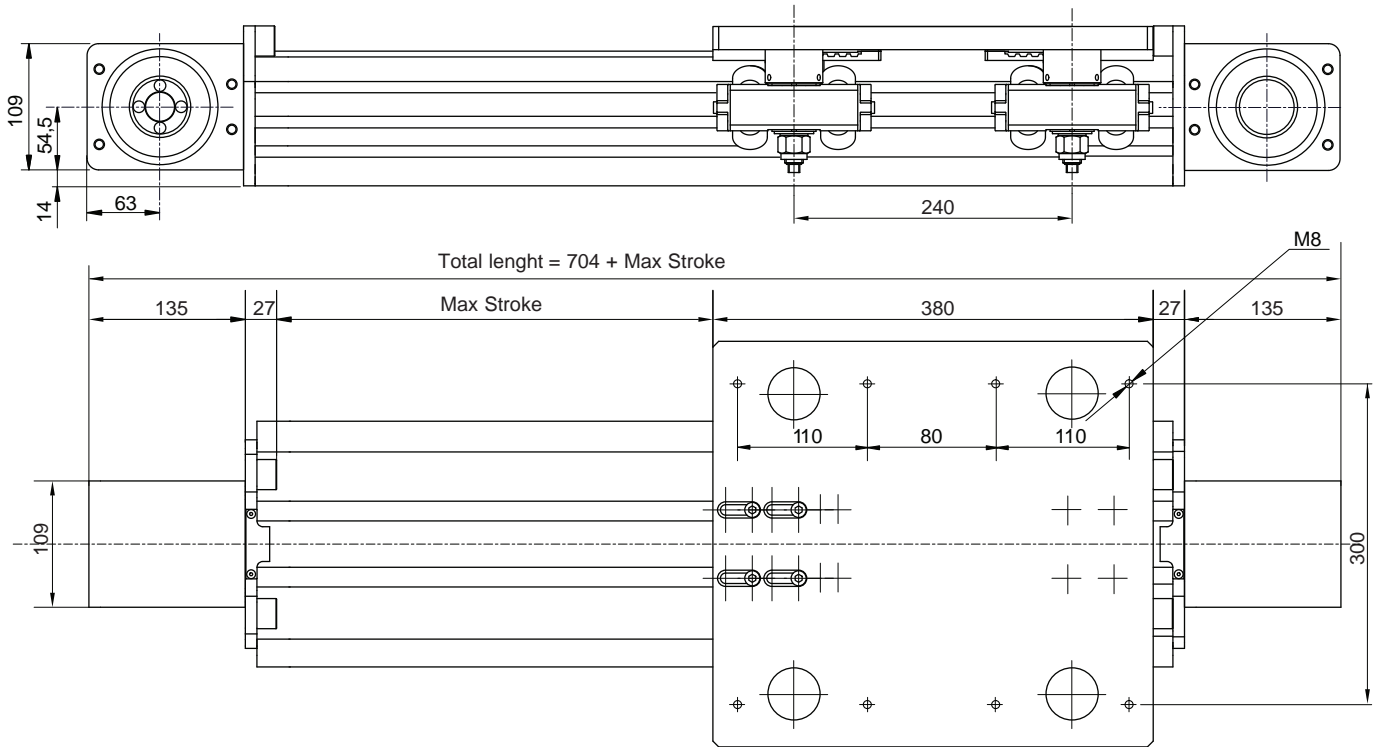

Recirculating ball slides

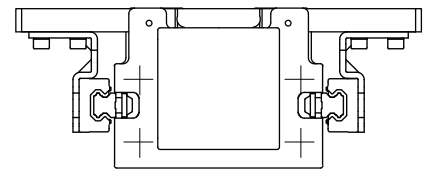

Roller slides

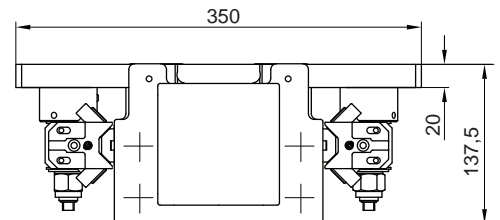

Performances	TECRR 180	
Max stroke	7.480	[mm]
Max speed	5	[m/s]
Max acceleration	20	[m/s <sup>2</sup> ]
Repositioning accuracy	± 0,1*	[mm]
Loadless torque	4,2	[Nm]

Suggested working load conditions						
Module	M <sub>x</sub> [Nm]	M <sub>y</sub> [Nm]	M <sub>z</sub> [Nm]	F <sub>x</sub> [N]	F <sub>y</sub> [N]	F <sub>z</sub> [N]
TECRR180	490	1.170	1.170	2.700	5.900	5.900

The dynamic values indicated do not correspond to maximum theoretical load capacities. They already take safety factors into account which are suitable for machinery in the automation sector. In the event of combined stress consult the technical support service.

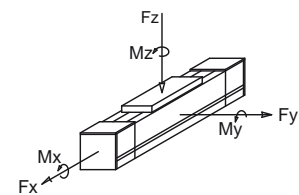

F<sub>x</sub>= Max belt strenght

Constructive data	
Belt	40ATL10
Sliding	4 slides 4 rollers Ø30 [mm]
Profile	180x90
Pulley Ø	92,31 [mm]
Linear displacement per revolution	290 [mm]

Weight	
Inertia of the pulley	0,0037 [kgm <sup>2</sup> ]
Belt weight	0,55 [kg/m]
Carriage weight	13 [kg]
Base module (stroke=0)	M <sub>base</sub> =33 [kg]
1.000 mm profile	q=16 [kg]

To calculate the module weight use the following formula:  $M = M_{base} + q \cdot \text{Stroke}_{max} / 1.000 \text{ Stroke}_{max} \text{ [mm]}$



Accessories: see page ML-10

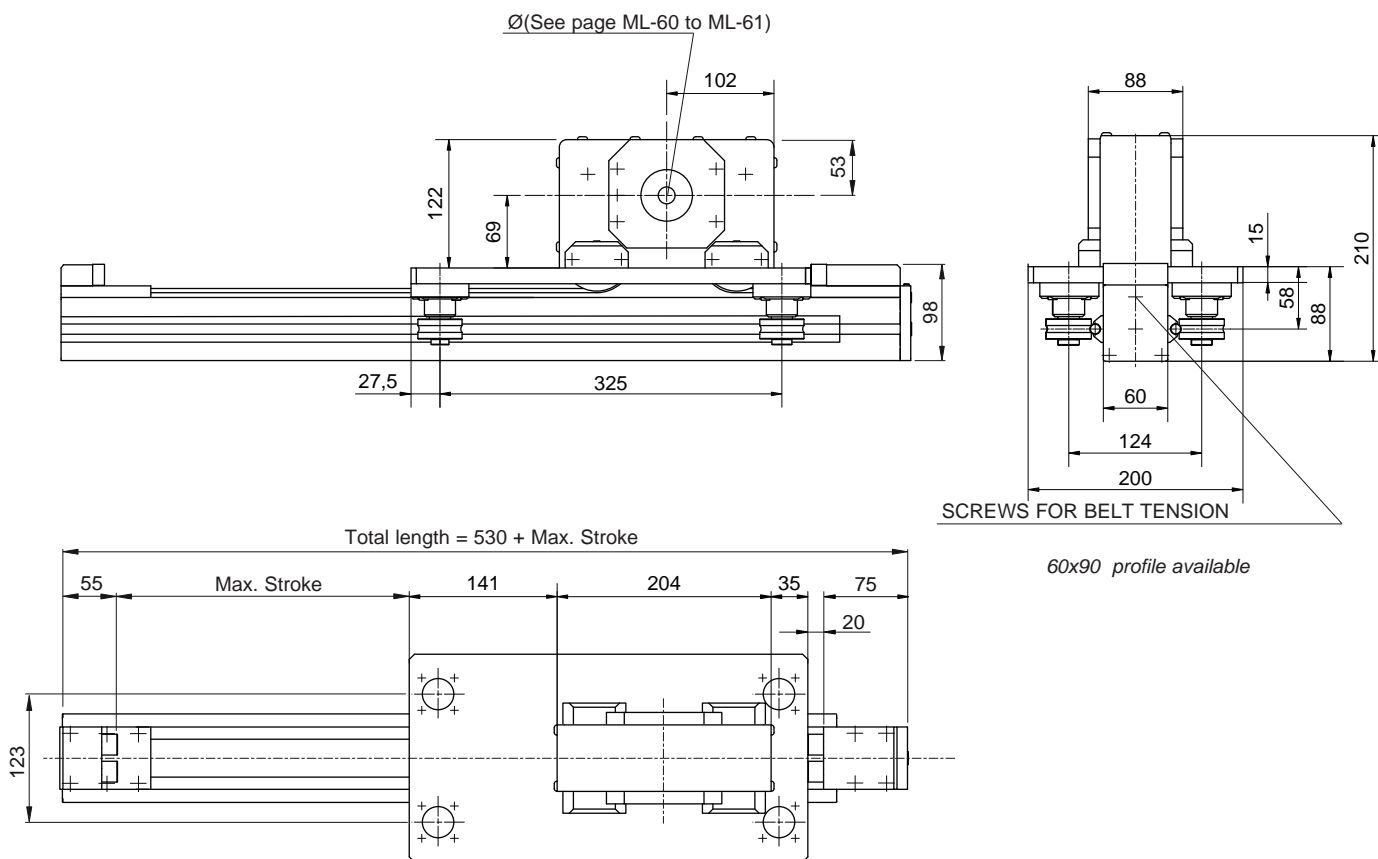

IMPORTANT: when pairing ZC... modules with TC... modules, please check the required Z axis stroke, as this could be limited by the size of the module plates sizes.

Performances	ZCG 60	
Max. stroke	5,470	[mm]
Max. speed	4	[m/s]
Max. acceration	20	[m/s <sup>2</sup> ]
Repeatability	± 0.1	[mm]

Suggested working load conditions						
Module	M <sub>x</sub> [Nm]	M <sub>y</sub> [Nm]	M <sub>z</sub> [Nm]	F <sub>x</sub> [N]	F <sub>y</sub> [N]	F <sub>z</sub> [N]
ZCG 60	60	200	340	2,000	2,100	1,500

The dynamic values shown do not refer to the max. theoretical load capacity. They include a safety coefficient for automated machinery. In case of peak forces acting together please ask the technical dept

Assembly positions and load direction, see page ML-10

Data	
Belt	32AT10
Slide	4 shaped roller slides Ø 42 [mm]
Load bearing profile	F01-1 (see page ML-11)
Pulley Ø	70.03 [mm]
Linear displacement per rev.	220 [mm]

Weights		
Inertia of the pulley	0.0013	[kgm <sup>2</sup> ]
Belt weight	0.19	[kg/m]
Carriage weight	10	[kg]
Base module (stroke=0)	M <sub>base</sub> =14	[kg]
1,000 mm profile	q=6	[kg]

To calculate the module weight use the following formula:  $M = M_{base} + q \cdot stroke_{max} / 1,000$  Stroke<sub>max</sub> [mm]

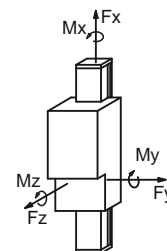

F<sub>x</sub>= Max belt strength

Accessories: see page ML-10

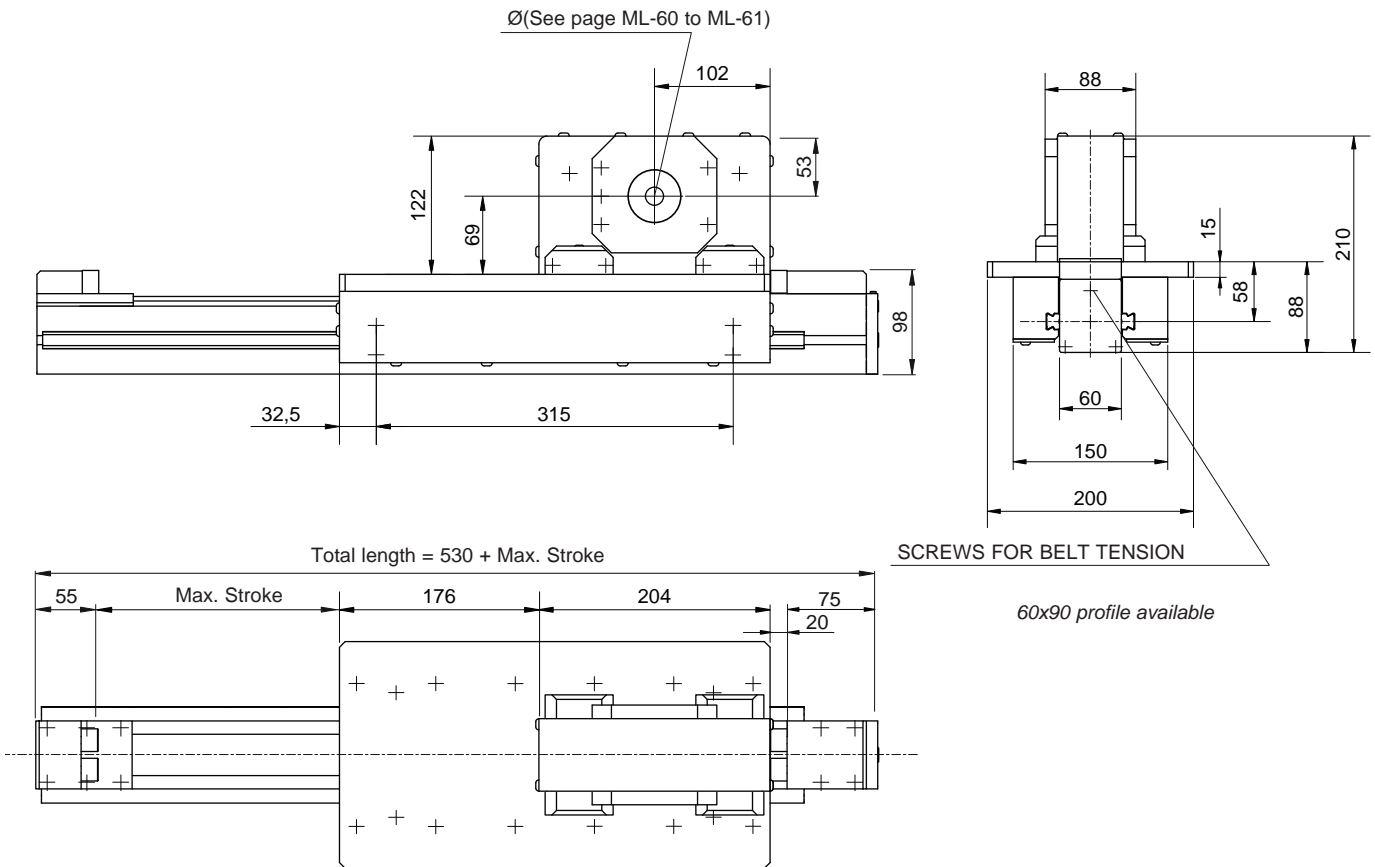

IMPORTANT: when pairing ZC... modules with TC... modules, please check the required Z axis stroke, as this could be limited by the size of the module plates sizes.

Performances	ZCL 60	
Max. stroke	5,470	[mm]
Max. speed	4	[m/s]
Max. acceleration	40	[m/s <sup>2</sup> ]
Repeatability	± 0.1	[mm]

Suggested working load conditions						
Module	M <sub>x</sub> [Nm]	M <sub>y</sub> [Nm]	M <sub>z</sub> [Nm]	F <sub>x</sub> [N]	F <sub>y</sub> [N]	F <sub>z</sub> [N]
ZCL 60	151	570	630	2,000	4,180	3,740

The dynamic values shown do not refer to the max. theoretical load capacity. They include a safety coefficient for automated machinery. In case of peak forces acting together please ask the technical dept

Data	
Belt	32AT10
Slide	4 caged ball roller slides 15
Load bearing profile	F01-1 (see page ML-11)
Pulley Ø	70.03 [mm]
Linear displacement per rev.	220 [mm]

Weights		
Inertia of the pulley	0.0013	[kgm <sup>2</sup> ]
Belt weight	0.19	[kg/m]
Carriage weight	11	[kg]
Base module (stroke=0)	M <sub>base</sub> =16	[kg]
1,000 mm profile	q=7.2	[kg]

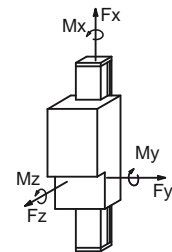

F<sub>x</sub> = Max belt strength

To calculate the module weight use the following formula:  $M = M_{base} + q \cdot stroke_{max} / 1,000$  Stroke<sub>max</sub> [mm]

Accessories: see page ML-10

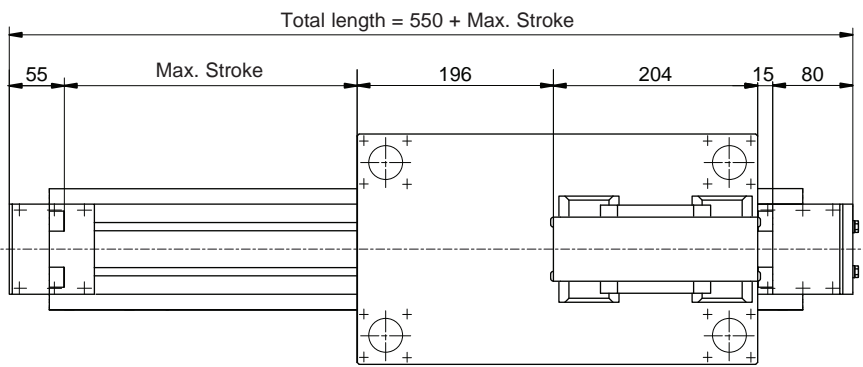
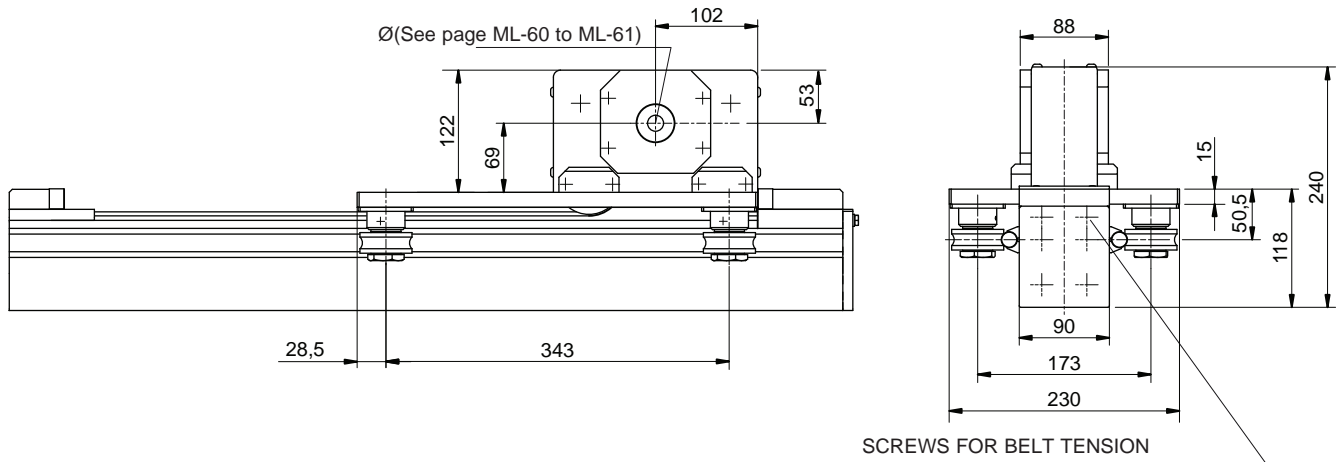

90x180 profile available

IMPORTANT: when pairing ZC... modules with TC... modules, please check the required Z axis stroke, as this could be limited by the size of the module plates sizes.

Performances	ZCG 90	
Max. stroke	5,450	[mm]
Max. speed	4	[m/s]
Max. acceleration	15	[m/s <sup>2</sup> ]
Repeatability	± 0.1	[mm]

Suggested working load conditions						
Module	M <sub>x</sub> [Nm]	M <sub>y</sub> [Nm]	M <sub>z</sub> [Nm]	F <sub>x</sub> [N]	F <sub>y</sub> [N]	F <sub>z</sub> [N]
ZCG 90	120	400	540	2,000	3,400	1,800

The dynamic values shown do not refer to the max. theoretical load capacity. They include a safety coefficient for automated machinery. In case of peak forces acting together please ask the technical dept

Assembly positions and load direction, see page ML-10

Data	
Belt	32AT10
Slide	4 shap. r. Ø52 - guide Ø16
Load bearing profile	E01-4 (see page ML-11)
Pulley Ø	70.03 [mm]
Linear displacement per rev.	220 [mm]

Weights		
Inertia of the pulley	0.0013	[kgm <sup>2</sup> ]
Belt weight	0.19	[kg/m]
Carriage weight	10.5	[kg]
Base module (stroke=0)	M <sub>base</sub> =16	[kg]
1.000 mm profile	q=8.5	[kg]

To calculate the module weight use the following formula:  $M = M_{base} + q \cdot stroke_{max} / 1,000$  Stroke<sub>max</sub> [mm]

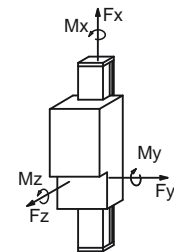

F<sub>x</sub> = Max belt strength

Accessories: see page ML-10

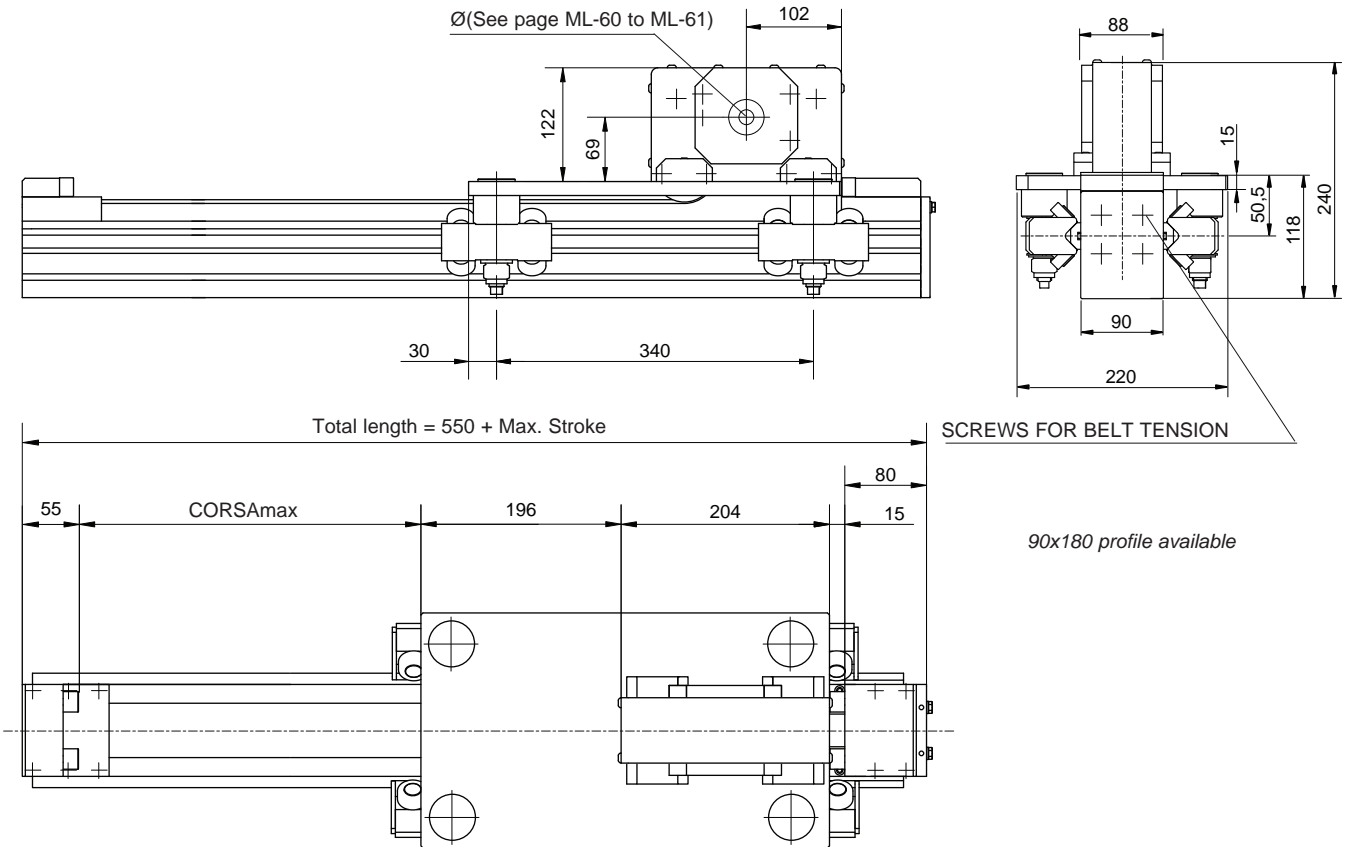

IMPORTANT: when pairing ZC... modules with TC... modules, please check the required Z axis stroke, as this could be limited by the size of the module plates sizes.

Performances	ZCRR 90	
Max. stroke	5,450	[mm]
Max. speed	4	[m/s]
Max. acceleration	25	[m/s <sup>2</sup> ]
Repeatability	± 0.1	[mm]

Suggested working load conditions						
Module	M <sub>x</sub> [Nm]	M <sub>y</sub> [Nm]	M <sub>z</sub> [Nm]	F <sub>x</sub> [N]	F <sub>y</sub> [N]	F <sub>z</sub> [N]
ZCRR 90	300	1,000	1,000	2,000	6,700	6,700

The dynamic values shown do not refer to the max. theoretical load capacity. They include a safety coefficient for automated machinery. In case of peak forces acting together please ask the technical dept

Assembly positions and load direction, see page ML-10

Data	
Belt	32 AT 10
Slide	4 slides 4 roll. Ø30 [mm]
Load bearing profile	E01-4 (see page ML-11)
Pulley Ø	70.03 [mm]
Linear displacement per rev.	220 [mm]

Weights		
Inertia of the pulley	0.0013	[kgm <sup>2</sup> ]
Belt weight	0.21	[kg/m]
Carriage weight	13	[kg]
Base module (stroke=0)	M <sub>base</sub> = 20	[kg]
1,000 mm profile	q=11.2	[kg]

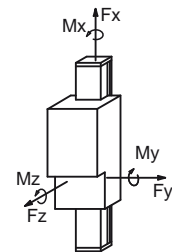

F<sub>x</sub>= Max belt strength

To calculate the module weight use the following formula:  $M = M_{base} + q \cdot stroke_{max} / 1,000$  Stroke<sub>max</sub> [mm]

Accessories: see page ML-10

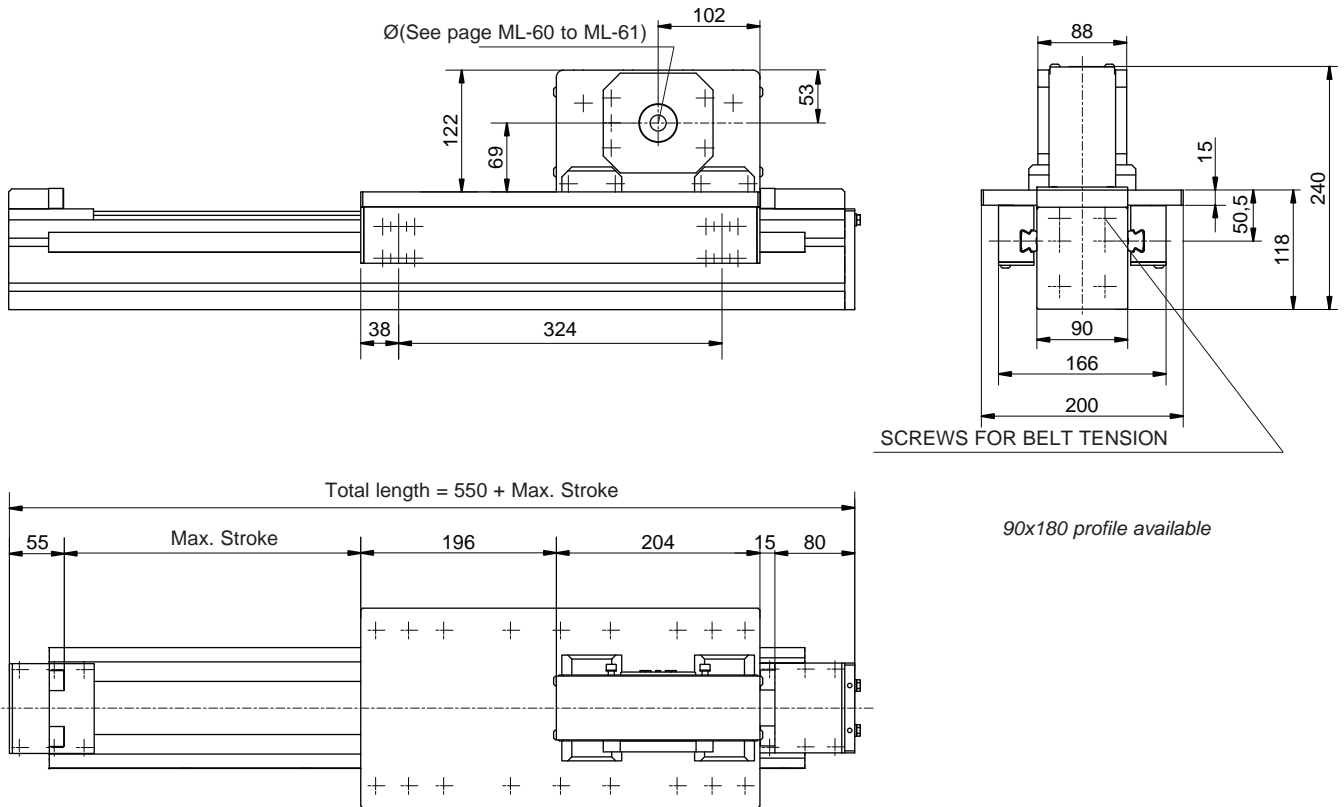

IMPORTANT: when pairing ZC... modules with TC... modules, please check the required Z axis stroke, as this could be limited by the size of the module plates sizes.

Performances	ZCL 90	
Max. stroke	5,450	[mm]
Max. speed	4	[m/s]
Max. acceleration	20	[m/s <sup>2</sup> ]
Repeatability	± 0.1	[mm]

Suggested working load conditions						
Module	M <sub>x</sub> [Nm]	M <sub>y</sub> [Nm]	M <sub>z</sub> [Nm]	F <sub>x</sub> [N]	F <sub>y</sub> [N]	F <sub>z</sub> [N]
ZCL 90	260	730	1,000	2,000	5,500	5,000

The dynamic values shown do not refer to the max. theoretical load capacity. They include a safety coefficient for automated machinery. In case of peak forces acting together please ask the technical dept

Data	
Belt	32AT10
Slide	4 caged ball roller slides 20
Load bearing profile	E01-4 (see page ML-11)
Pulley Ø	70.03 [mm]
Linear displacement per rev.	220 [mm]

Weights		
Inertia of the pulley	0.0013	[kgm <sup>2</sup> ]
Belt weight	0.19	[kg/m]
Carriage weight	11.5	[kg]
Base module (stroke=0)	M <sub>base</sub> =18.5	[kg]
1,000 mm profile	q=11.5	[kg]

To calculate the module weight use the following formula:  $M = M_{base} + q \cdot stroke_{max} / 1,000$  Stroke<sub>max</sub> [mm]

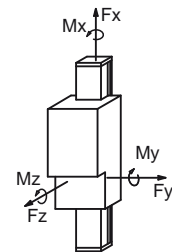

F<sub>x</sub> = Max belt strength

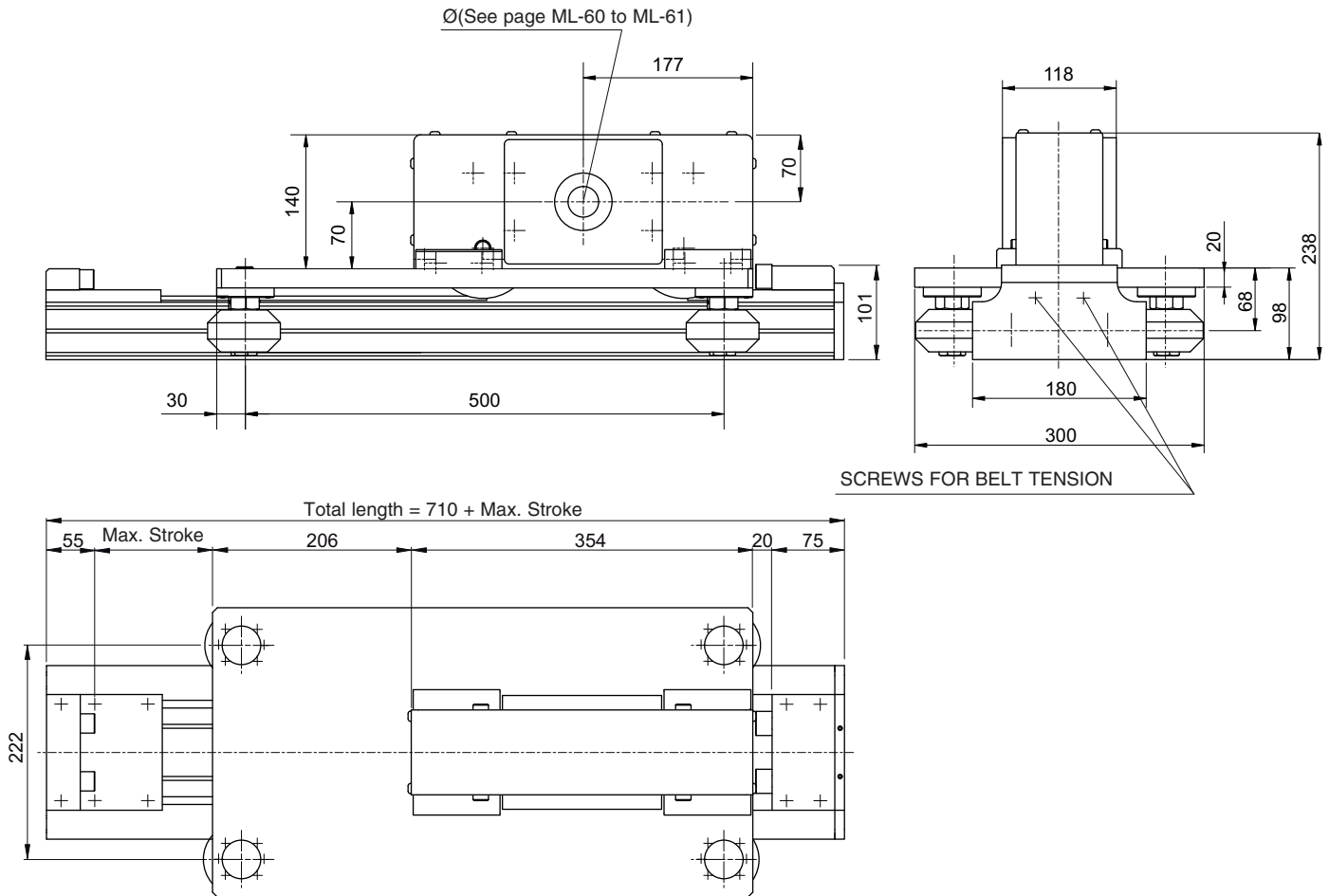

IMPORTANT: when pairing ZC... modules with TC... modules, please check the required Z axis stroke, as this could be limited by the size of the module plates sizes.

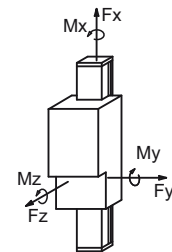

Fx= Max belt strength

Performances	ZCY 180	
Max. stroke	6,750	[mm]
Max. speed	4	[m/s]
Max. acceleration	15	[m/s <sup>2</sup> ]
Repeatability	± 0.6	[mm]

Suggested working load conditions						
Module	M <sub>x</sub> [Nm]	M <sub>y</sub> [Nm]	M <sub>z</sub> [Nm]	F <sub>x</sub> [N]	F <sub>y</sub> [N]	F <sub>z</sub> [N]
ZCY 180	220	350	280	3,000	2,400	1,800

The dynamic values shown do not refer to the max. theoretical load capacity. They include a safety coefficient for automated machinery. In case of peak forces acting together please ask the technical dept

Assembly positions and load direction, see page ML-10

Data	
Belt	50ATL10
Slide	4 Rollers Ø 76 [mm]
Load bearing profile	Sys -1G (see page ML-14)
Pulley Ø	95.49 [mm]
Linear displacement per rev.	300 [mm]

Weights	
Inertia of the pulley	0.0067 [kgm <sup>2</sup> ]
Belt weight	0.34 [kg/m]
Carriage weight	23.2 [kg]
Base module (stroke=0)	M <sub>base</sub> =33.5 [kg]
1,000 mm profile	q=11.61 [kg]

To calculate the module weight use the following formula:  $M = M_{base} + q \cdot stroke_{max} / 1,000$  Stroke<sub>max</sub> [mm]

SUITABLE FOR VERTICAL AND HORIZONTAL ASSEMBLY  
Accessories: see page ML-10

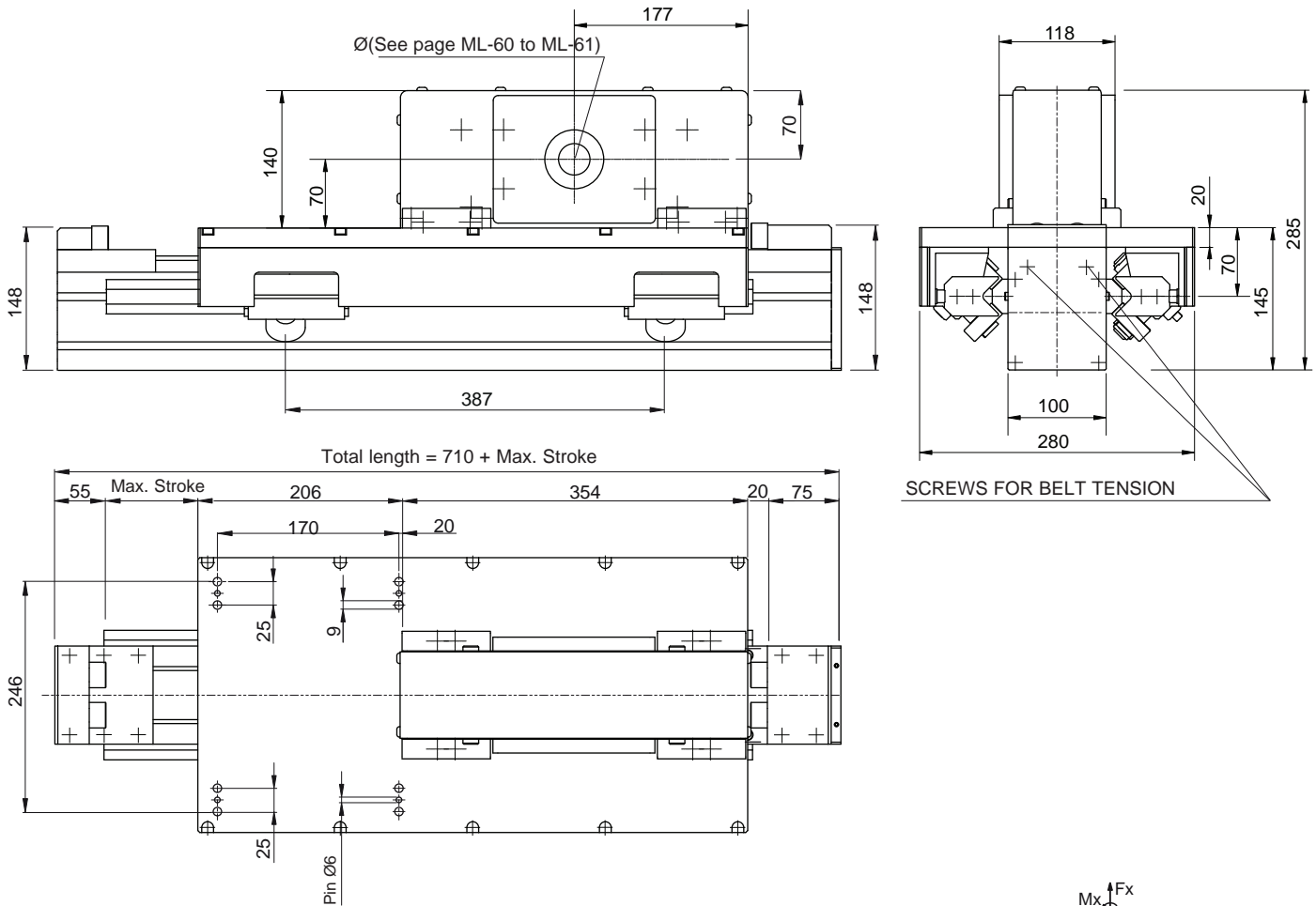

IMPORTANT: when pairing ZC... modules with TC... modules, please check the required Z axis stroke, as this could be limited by the size of the module plates sizes.

Performances	ZCRQ 100	
Max. stroke	5,300	[mm]
Max. speed	4	[m/s]
Max. acceleration	25	[m/s <sup>2</sup> ]
Repeatability	± 0.1	[mm]

Suggested working load conditions						
Module	M <sub>x</sub> [Nm]	M <sub>y</sub> [Nm]	M <sub>z</sub> [Nm]	F <sub>x</sub> [N]	F <sub>y</sub> [N]	F <sub>z</sub> [N]
ZCRQ 100	360	1,200	1,200	4,000	7,320	7,320

The dynamic values shown do not refer to the max. theoretical load capacity. They include a safety coefficient for automated machinery. In case of peak forces acting together please ask the technical dept

Assembly positions and load direction, see page ML-10

Data	
Belt	50 ATL 10
Slide	4 slides 2 roll. Ø 40 [mm]
Load bearing profile	MA 1-5 (see page ML-12)
Pulley Ø	95.49 [mm]
Linear displacement per rev.	300 [mm]

Weights	
Inertia of the pulley	0.0067 [kgm <sup>2</sup> ]
Belt weight	0.34 [kg/m]
Carriage weight	25 [kg]
Base module (stroke=0)	M <sub>base</sub> =36.5 [kg]
1,000 mm di profile	q=16.5 [kg]

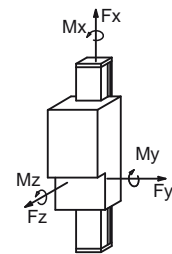

F<sub>x</sub> = Max belt strength

To calculate the module weight use the following formula:  $M = M_{base} + q \cdot stroke_{max} / 1,000$  Stroke<sub>max</sub> [mm]

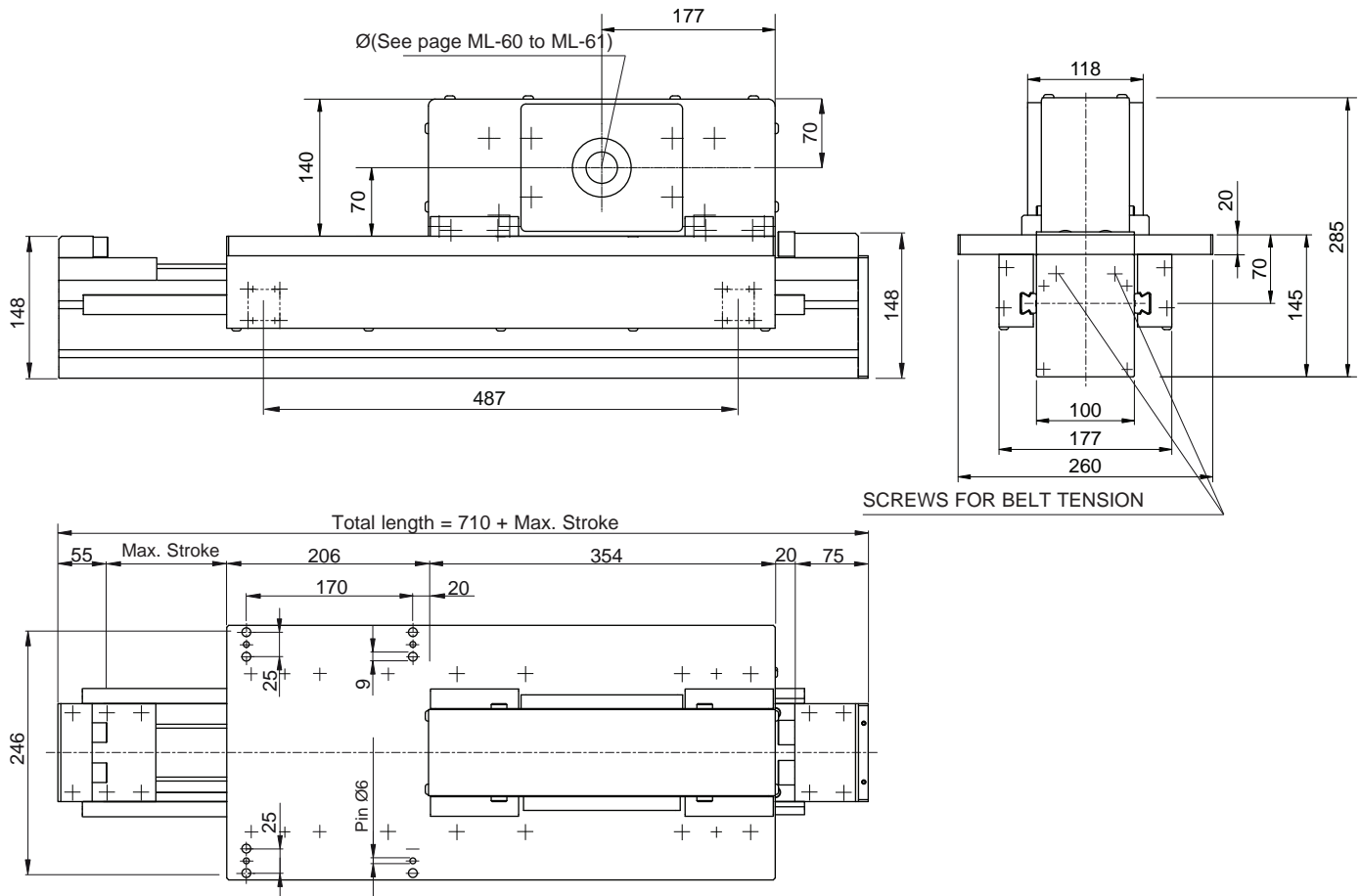

SCREWS FOR BELT TENSION

IMPORTANT: when pairing ZC... modules with TC... modules, please check the required Z axis stroke, as this could be limited by the size of the module plates sizes.

Performances	ZCS 100	
Max. stroke	5,300	[mm]
Max. speed	4	[m/s]
Max. acceleration	25	[m/s <sup>2</sup> ]
Repeatability	± 0.1	[mm]

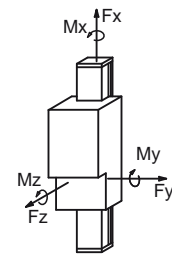

F<sub>x</sub> = Max belt strength

### Suggested working load conditions

Module	M <sub>x</sub> [Nm]	M <sub>y</sub> [Nm]	M <sub>z</sub> [Nm]	F <sub>x</sub> [N]	F <sub>y</sub> [N]	F <sub>z</sub> [N]
ZCS 100	480	1,630	1,840	4,000	7,360	8,260

The dynamic values shown do not refer to the max. theoretical load capacity. They include a safety coefficient for automated machinery. In case of peak forces acting together please ask the technical dept

Data	
Belt	50 ATL 10
Slide	4 caged ball roller slides 20
Load bearing profile	MA 1-5 (see page ML-12)
Pulley Ø	95.49 [mm]
Linear displacement per rev.	300 [mm]

Weights	
Inertia of the pulley	0.0067 [kgm <sup>2</sup> ]
Belt weight	0.34 [kg/m]
Carriage weight	24.4 [kg]
Base module (stroke=0)	M <sub>base</sub> =36.6 [kg]
1,000 mm profile	q=15.2 [kg]

To calculate the module weight use the following formula:  $M = M_{base} + q \cdot stroke_{max} / 1,000$  Stroke<sub>max</sub> [mm]



# ZCRQ 170 - ZCERQ 170

OMEGA BELT DRIVE  
V-SHAPED GUIDE RAILS AND ROLLER SLIDES  
SUITABLE FOR VERTICAL AND HORIZONTAL ASSEMBLY

Modline

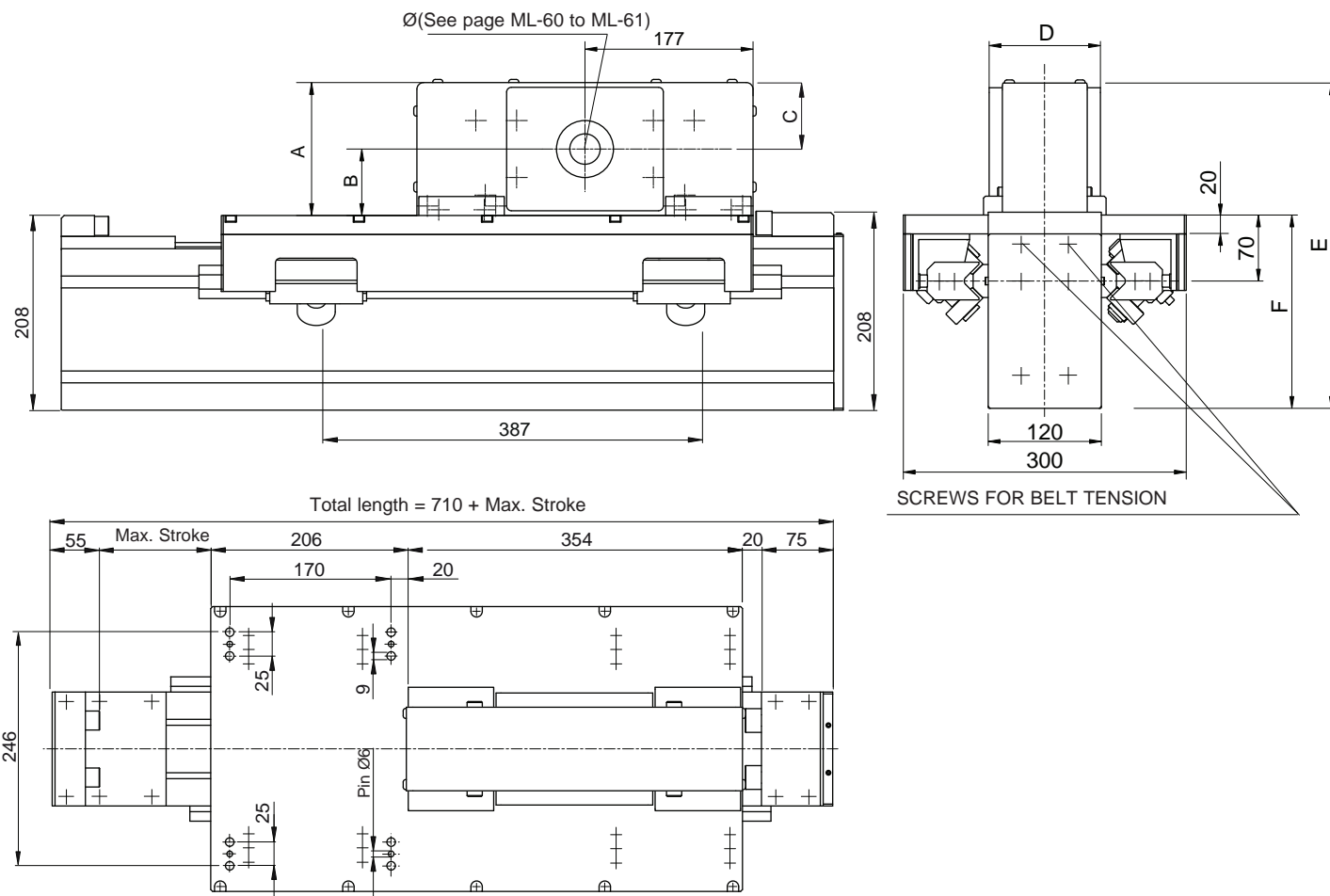

IMPORTANT: when pairing ZC... modules with TC... modules, please check the required Z axis stroke, as this could be limited by the size of the module plates sizes.

## Performances ZCRQ 170 - ZCERQ 170

Max. stroke	5,300	[mm]
Max. speed	4	[m/s]
Max. acceleration	25	[m/s <sup>2</sup> ]
Repeatability	± 0.1	[mm]

## Suggested working load conditions

Module	M <sub>x</sub> [Nm]	M <sub>y</sub> [Nm]	M <sub>z</sub> [Nm]	F <sub>x</sub> [N]	F <sub>y</sub> [N]	F <sub>z</sub> [N]
ZCRQ 170	440	1,485	1,485	4,000	7,620	7,620
ZCERQ 170	440	1,485	1,485	6,000	7,620	7,620

The dynamic values shown do not refer to the max. theoretical load capacity. They include a safety coefficient for automated machinery. In case of peak forces acting together please ask the technical dept

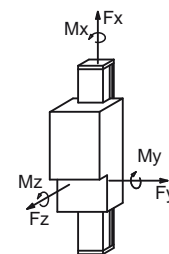

F<sub>x</sub>= Max belt strength

## Assembly positions and load direction, see page ML-10

Data	ZCRQ 170	ZCERQ 170
Belt	50 ATL 10	75 ATL 10
Slide	4 slides 2 roll. Ø 40 [mm]	
Load bearing profile	Statyca (see page ML-13)	
Pulley Ø	95.49 [mm]	
Linear displacement per rev. 300	[mm]	

Weights	ZCRQ 170	ZCERQ 170
Inertia of the pulley	0.0067	0.010 [kgm <sup>2</sup> ]
Belt weight	0.34	0.51 [kg/m]
Carriage weight	27.6	32 [kg]
Base module (stroke=0)	M <sub>base</sub> =47	M <sub>base</sub> =51.4 [kg]
1,000 mm profile	q=25	q=25 [kg]

Belt	A	B	C	D	E	F
50	140	70	70	118	345	205
75	164	82	82	143	379	215

To calculate the module weight use the following formula:  $M = M_{base} + q \cdot stroke_{max} / 1,000$  Stroke<sub>max</sub> [mm]

# ZCL 170 - ZCEL 170

## OMEGA BELT DRIVE GUIDE RAILS WITH CAGED BALL ROLLER SLIDES

SUITABLE FOR VERTICAL AND HORIZONTAL ASSEMBLY

Accessories: see page ML-10

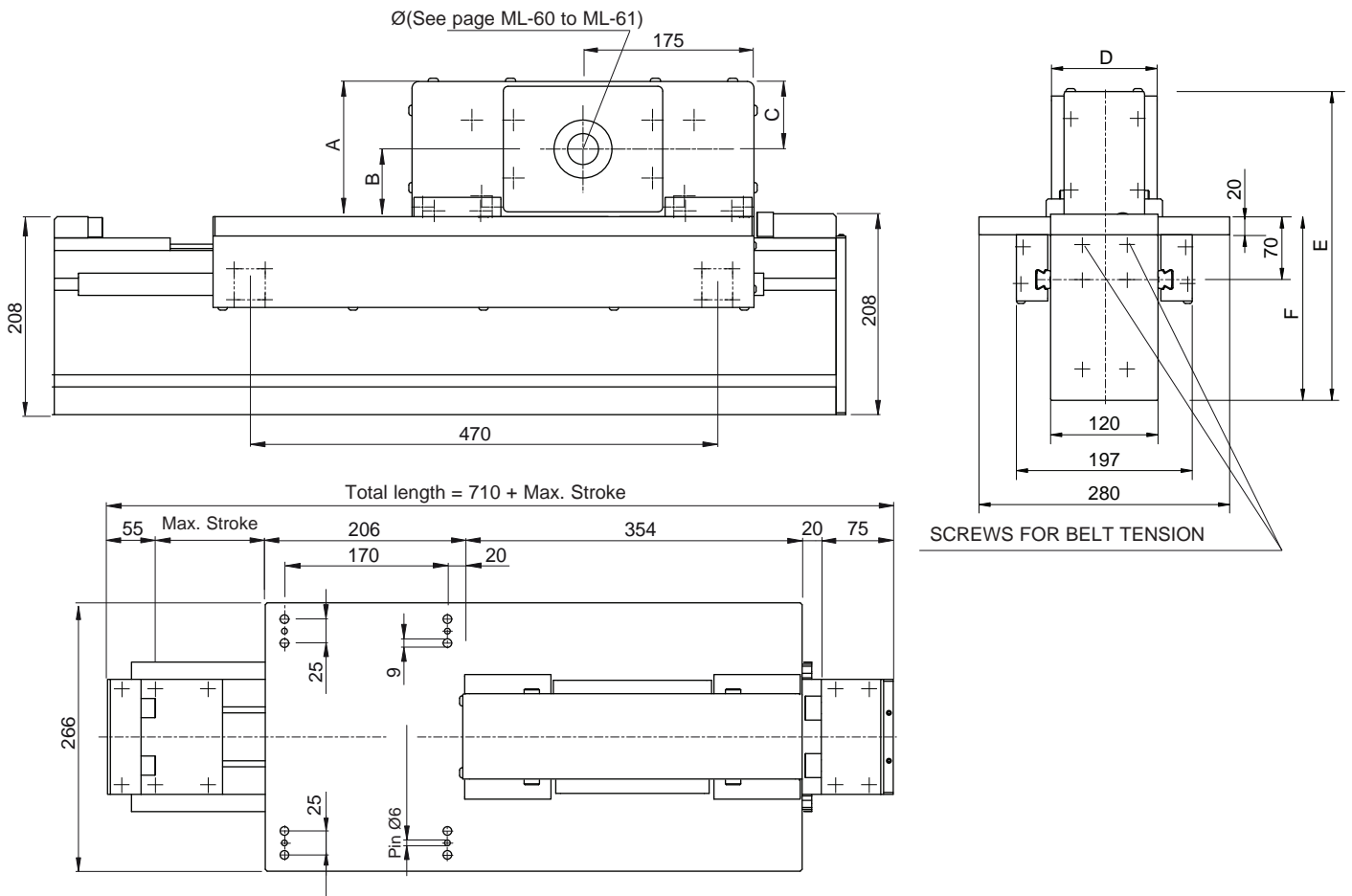

IMPORTANT: when pairing ZC... modules with TC... modules, please check the required Z axis stroke, as this could be limited by the size of the module plates sizes.

### Performances ZCL 170 - ZCEL 170

Max. stroke	5,300	[mm]
Max. speed	4	[m/s]
Max. acceleration	25	[m/s <sup>2</sup> ]
Repeatability	± 0.1	[mm]

### Suggested working load conditions

Module	M <sub>x</sub> [Nm]	M <sub>y</sub> [Nm]	M <sub>z</sub> [Nm]	F <sub>x</sub> [N]	F <sub>y</sub> [N]	F <sub>z</sub> [N]
ZCL 170	810	2,940	4,560	4,000	10,400	12,000
ZCEL 170	810	2,940	4,560	6,000	10,400	12,000

The dynamic values shown do not refer to the max. theoretical load capacity. They include a safety coefficient for automated machinery. In case of peak forces acting together please ask the technical dept

Data	ZCL 170	ZCEL 170
Belt	50 ATL 10	75 ATL 10
Slide	4 caged ball roller slides 25	
Load bearing profile	Statyca (see page ML-13)	
Pulley Ø	95.49 [mm]	
Linear displacement per rev.	300 [mm]	

Weights	ZCL 170	ZCEL 170	
Inertia of the pulley	0.0067	0.010	[kgm <sup>2</sup> ]
Belt weight	0.34	0.51	[kg/m]
Carriage weight	27.6	31.6	[kg]
Base module (stroke=0)	M <sub>base</sub> =46.2	M <sub>base</sub> =50.2	[kg]
1,000 mm profile	q=24	q=24	[kg]

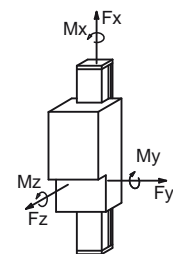

F<sub>x</sub> = Max belt strength

Belt	A	B	C	D	E	F
50	140	70	70	118	345	205
75	164	82	82	143	379	215

To calculate the module weight use the following formula:  $M = M_{base} + q \cdot \text{stroke}_{max} / 1,000$  Stroke<sub>max</sub> [mm]

# ZCRQ 220 - ZCERQ 220

OMEGA BELT DRIVE  
V-SHAPED GUIDE RAILS AND ROLLER SLIDES

Modline

SUITABLE FOR VERTICAL AND HORIZONTAL ASSEMBLY  
Accessories: see page ML-10

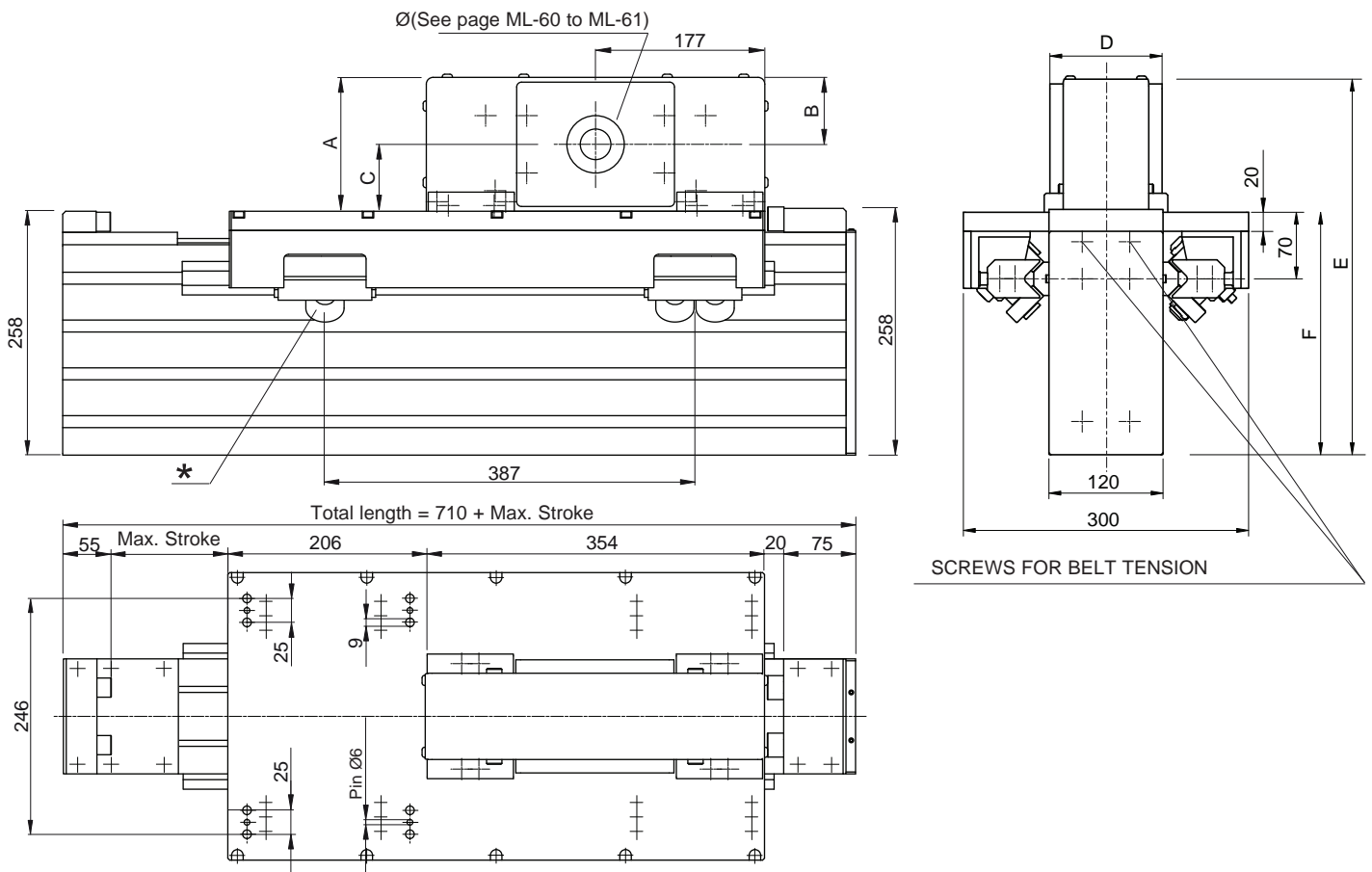

IMPORTANT: when pairing ZC... modules with TC... modules, please check the required Z axis stroke, as this could be limited by the size of the module plates sizes.

\*: Please specify the roller orientation according to the barycentre of the applied load. Values corresponding to the most favourable load position.

## Performances ZCRQ 220 - ZCERQ 220

Max. stroke	11,300	[mm]
Mas. speed	4	[m/s]
Max. acceleration	25	[m/s <sup>2</sup> ]
Repeatability	± 0.1	[mm]

## Suggested working load conditions

Module	M <sub>x</sub> [Nm]	M <sub>y</sub> [Nm]	M <sub>z</sub> [Nm]	F <sub>x</sub> [N]	F <sub>y</sub> [N]	F <sub>z</sub> [N]
ZCRQ 220	440	1,900(*)	1,485	4,000	7,620	9,500(*)
ZCERQ 220	440	1,900(*)	1,485	6,000	7,620	9,500(*)

The dynamic values shown do not refer to the max. theoretical load capacity. They include a safety coefficient for automated machinery. In case of peak forces acting together please ask the technical dept

Assembly positions and load direction, see page ML-10

Data	ZCRQ 220	ZCERQ 220
Belt	50 ATL 10	75 ATL 10
Slide	4 slides 3 rollers Ø 40 [mm]	
Load bearing profile	Logyca (see page ML-13)	
Pulley Ø	95.49	[mm]
Linear displacement per rev.	300	[mm]

Weights	ZCRQ 220	ZCERQ 220	
Inertia of the pulley	0.0067	0.010	[kgm <sup>2</sup> ]
Belt weight	0.34	0.51	[kg/m]
Carriage weight	26	30	[kg]
Base module (stroke=0)	M <sub>base</sub> =52	M <sub>base</sub> =56	[kg]
1,000 mm profile	q=33.6	q=34	[kg]

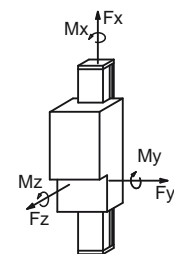

F<sub>x</sub>= Max belt strength

Belt	A	B	C	D	E	F
50	140	70	70	118	395	255
75	164	82	82	143	429	265

To calculate the module weight use the following formula:  $M = M_{base} + q \cdot stroke_{max} / 1,000$  Stroke<sub>max</sub> [mm]

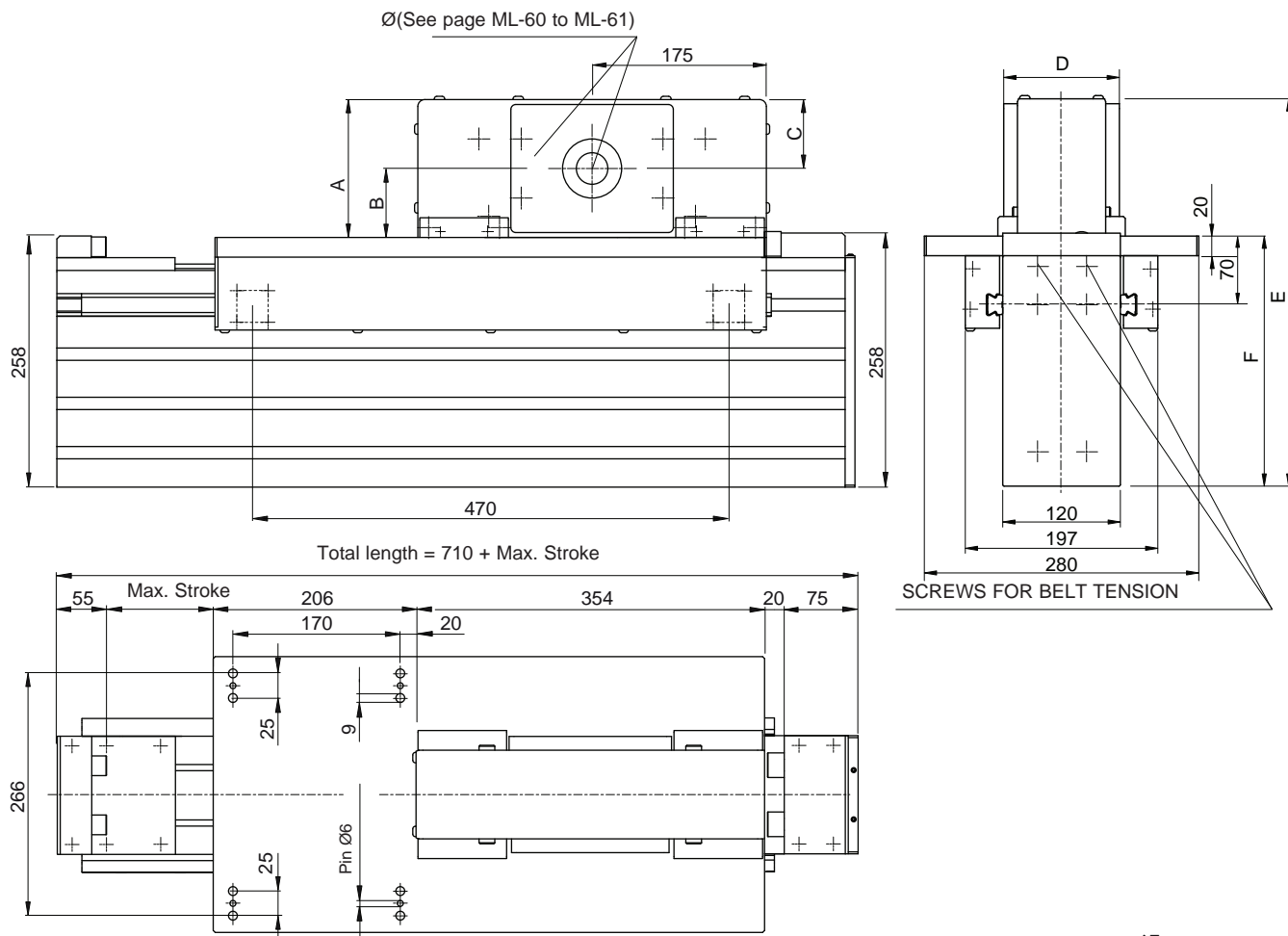

IMPORTANT: when pairing ZC... modules with TC... modules, please check the required Z axis stroke, as this could be limited by the size of the module plates sizes.

Performances		ZCL 220 - ZCEL 220	
Max. stroke	11,305	[mm]	
Max. speed	4	[m/s]	
Max. acceleration	25	[m/s <sup>2</sup> ]	
Repeatability	± 0.1	[mm]	

Suggested working load conditions						
Module	M <sub>x</sub> [Nm]	M <sub>y</sub> [Nm]	M <sub>z</sub> [Nm]	F <sub>x</sub> [N]	F <sub>y</sub> [N]	F <sub>z</sub> [N]
ZCL 220	810	2,940	4,560	4,000	10,400	12,000
ZCEL 220	810	2,940	4,560	6,000	10,400	12,000

The dynamic values shown do not refer to the max. theoretical load capacity. They include a safety coefficient for automated machinery. In case of peak forces acting together please ask the technical dept

Data	ZCL 220	ZCEL 220
Belt	50 ATL 10	75 ATL 10
Slide	4 caged ball roller slides 25	
Load bearing profile	Logyca (see page ML-13)	
Pulley Ø	95.49	[mm]
Linear displacement per rev.	300	[mm]

Weights	ZCL 220	ZCEL 220	
Inertia of the pulley	0.0067	0.010	[kgm <sup>2</sup> ]
Belt weight	0.34	0.51	[kg/m]
Carriage weight	27.5	37.5	[kg]
Base module (stroke=0)	M <sub>base</sub> =53	M <sub>base</sub> =57	[kg]
1,000 mm profile	q=32.3	q=32.7	[kg]

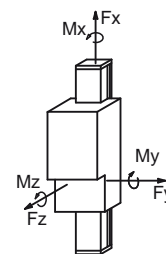

F<sub>x</sub> = Max belt strength

Belt	A	B	C	D	E	F
50	140	70	70	118	395	255
75	164	82	82	143	429	265

To calculate the module weight use the following formula:  $M = M_{base} + q \cdot stroke_{max} / 1,000$  Stroke<sub>max</sub> [mm]

# ZMCPLL 105 - ZMCLL 105 OMEGA BELT DRIVE SUITABLE FOR VERTICAL ASSEMBLY

Modline

Patent pending

LOAD COMPENSATION WITH INTEGRATED PNEUMATIC CYLINDER

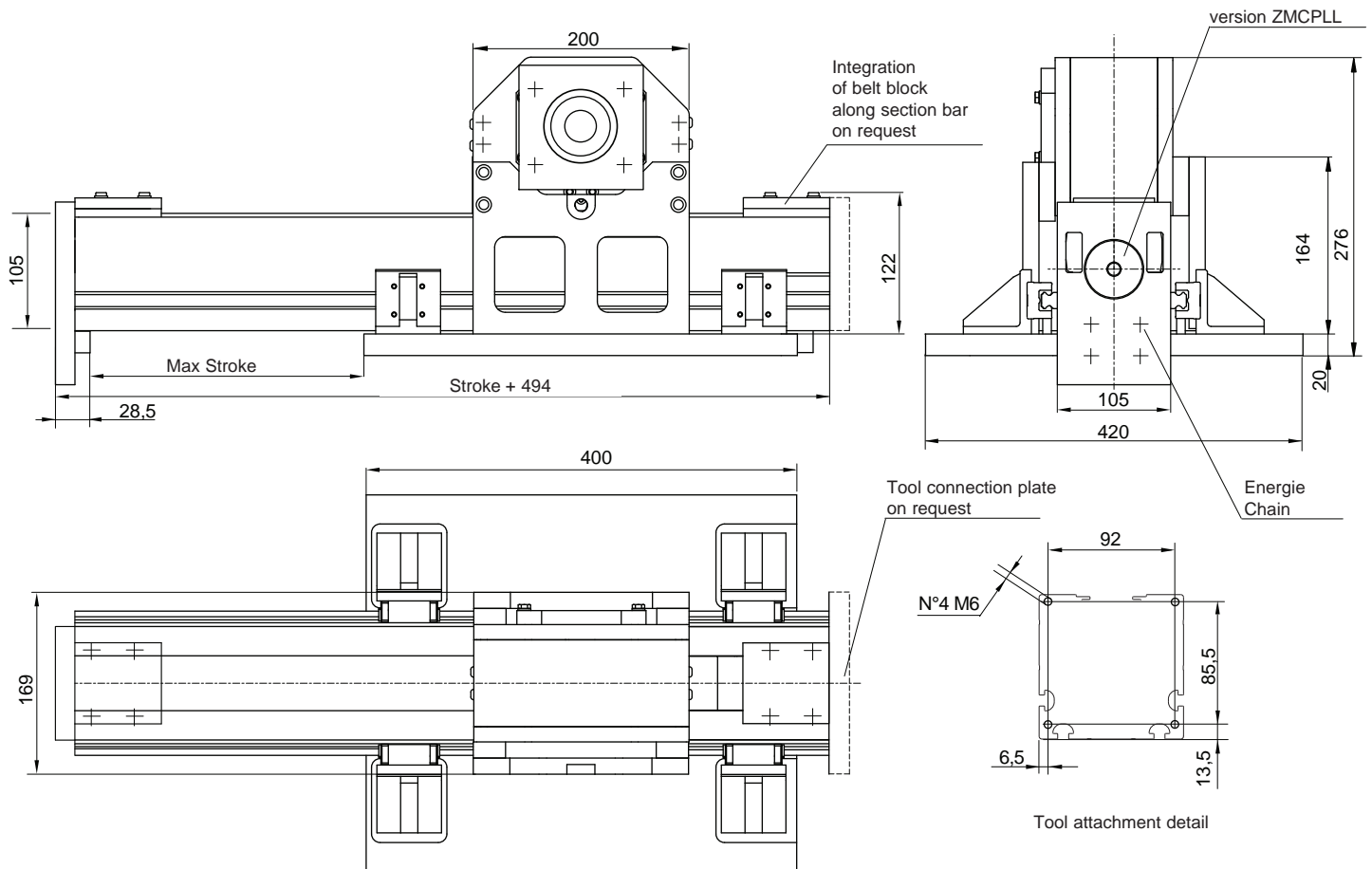

## Performances ZMCPLL 105

Integrated pneumatic cylinder	Ø 50	[mm]
Maximum cylinder stroke	2000	[mm]
Max Speed	3	[m/s]
Maximum acceleration	25	[m/s <sup>2</sup> ]
Repositioning precision	± 0,1	[mm]

## Suggested working load conditions

Module	M <sub>x</sub> [Nm]	M <sub>y</sub> [Nm]	M <sub>z</sub> [Nm]	F <sub>x</sub> [N]	F <sub>y</sub> [N]	F <sub>z</sub> [N]
ZMCPLL105	260	700	700	2.500	4.500	4.500

The dynamic values indicated do not correspond to maximum theoretical load capacities. They already take safety factors into account which are suitable for machinery in the automation sector. In the event of combined stress consult the technical support service.

## Constructive data

Belt	50 AT 10
Slide	4 ball slides size 15 [mm]
Profile	M105
Pulley Ø	92,3 [mm]
Linear displacement per revolution	290 [mm]

## Weights

Inertia of the pulley	-	[kgm <sup>2</sup> ]
Belt weight	0,30	[kg/m]
Carriage weight	29	[kg]
Base Module (stroke=0)	M <sub>base</sub> = 37	[kg]
1.000 profile	q=15	[kg]

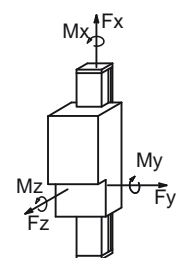

F<sub>x</sub> = Max belt strenght

To calculate the module weight use the following formula:  $M = M_{base} + q \cdot \text{Stroke}_{max} / 1.000 \text{ Stroke}_{max} \text{ [mm]}$

# ZMCH 105

OMEGA BELT DRIVE SUITABLE FOR VERTICAL ASSEMBLY

Patent pending

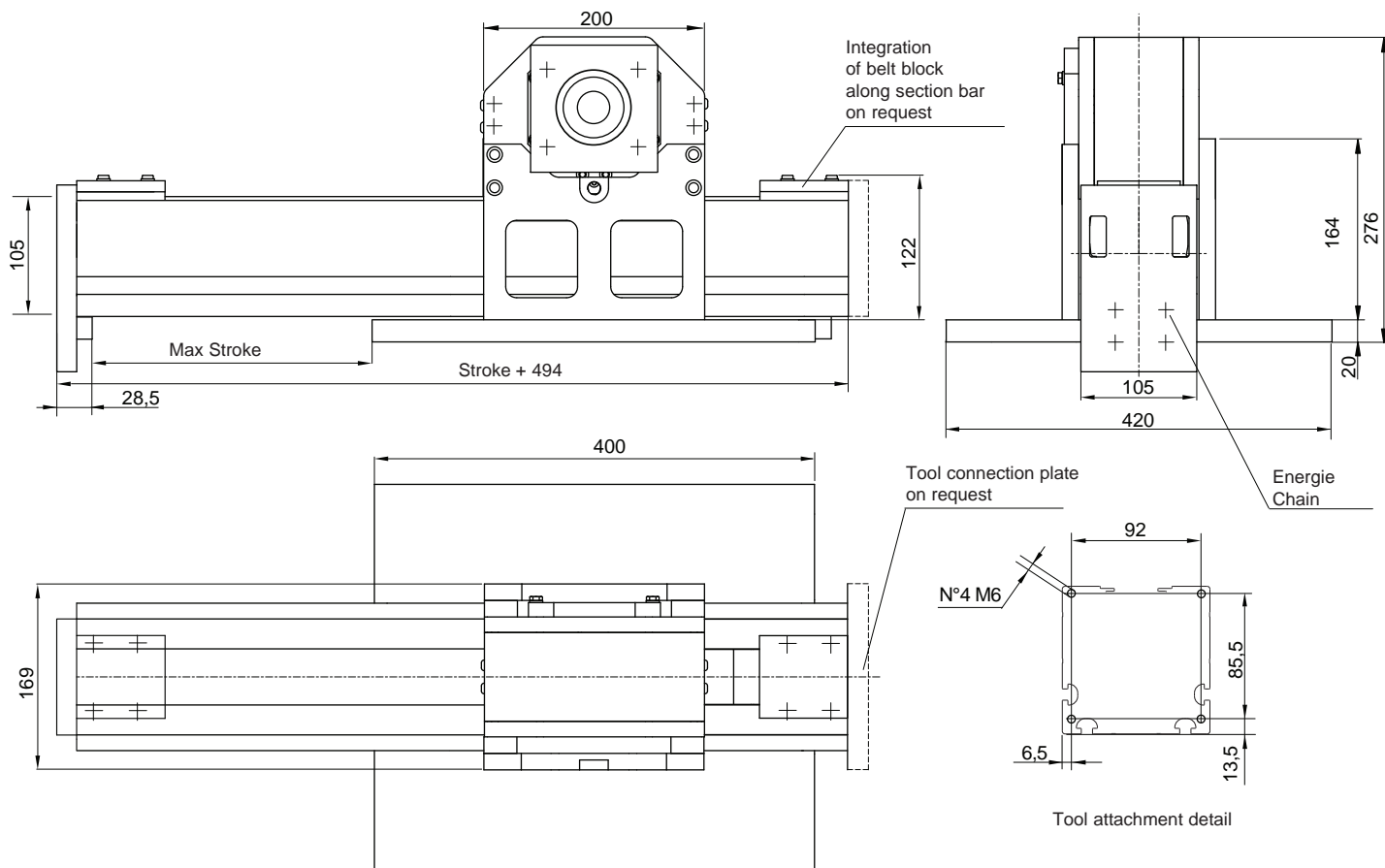

Performances	ZMCH 105	
Max Speed	3	[m/s]
Max Acceleration	25	[m/s <sup>2</sup> ]
Repositioning accuracy	± 0,1	[mm]

Suggested working load conditions						
Module	M <sub>x</sub> [Nm]	M <sub>y</sub> [Nm]	M <sub>z</sub> [Nm]	F <sub>x</sub> [N]	F <sub>y</sub> [N]	F <sub>z</sub> [N]
ZMCH105	260	700	700	2.500	4.500	4.500

The dynamic values indicated do not correspond to maximum theoretical load capacities. They already take safety factors into account which are suitable for machinery in the automation sector. In the event of combined stress consult the technical support service.

Constructive data	
Belt	50 AT 10
Sliding	4 ball slides size 15 [mm]
Profile	M105
Pulley Ø	92,3 [mm]
Linear displacement per revolution	290 [mm]

Weights	
Inertia of the pulley	- [kgm <sup>2</sup> ]
Belt weight	0,30 [kg/m]
Carriage weight	29 [kg]
Base module (stroke=0)	M <sub>base</sub> = 37 [kg]
1.000 mm profile	q=15 [kg]

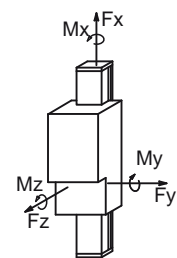

F<sub>x</sub>= Max belt strenght

To calculate the module weight use the following formula:  $M = M_{base} + q \cdot Stroke_{max} / 1.000$  Stroke<sub>max</sub> [mm]

**KCH 100/150/200**

GEAR MOTOR ASSEMBLY POSSIBLE FROM EACH SIDE

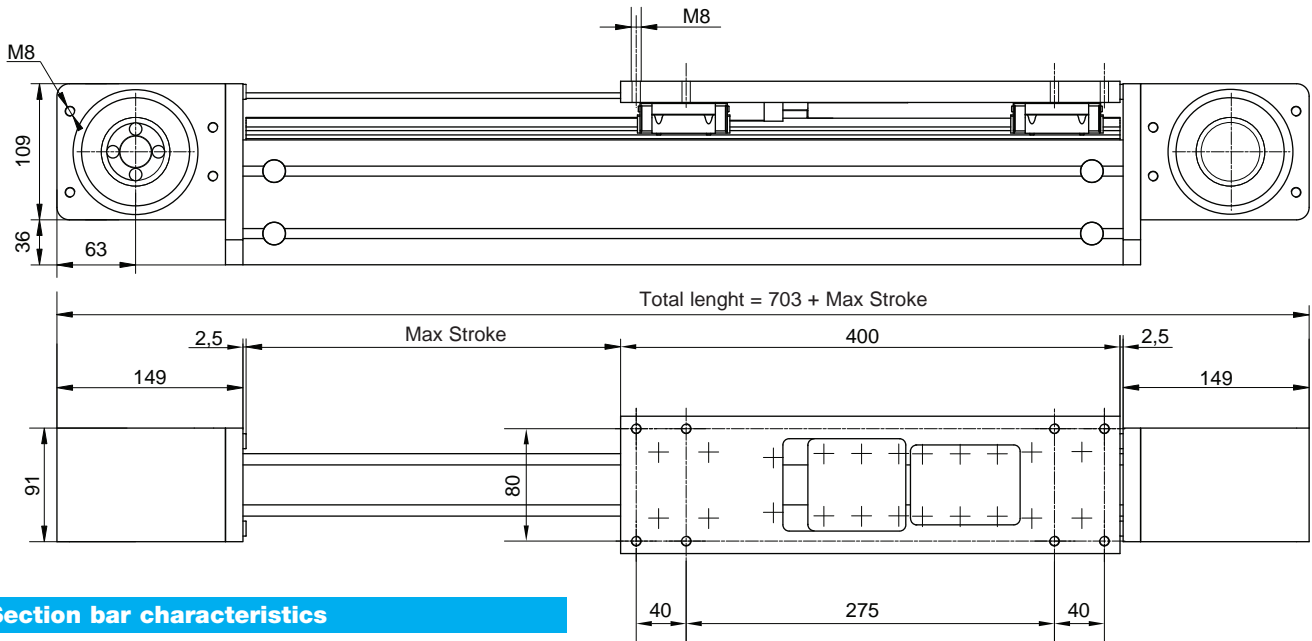

**Section bar characteristics**

Module	Mx	My	Weight [Kg/m]
KCH 100	203	54	4,6
KCH 150	30	60	7,1
KCH 200	40	80	9,0

**Shrink disc interface**

\*Pulley hole (motor side = pipe side) Ø14 wrench 5x5 \* [mm]  
 Interfaces with conical shrink discs and/or pulleys in steel are available on request. The heads are equal  
 Belt adjustment under load (does not require dismantling of equipment)

Performances	KCH / ...	
Max stroke	5.600	[mm]
Max speed	4	[m/s]
Max acceleration	50	[m/s <sup>2</sup> ]
Repositioning accuracy	± 0,1*	[mm]
Loadless torque	-	[Nm]

\*on request ± 0,05

**Suggested working load conditions**

Modulo	M <sub>x</sub> [Nm]	M <sub>y</sub> [Nm]	M <sub>z</sub> [Nm]	F <sub>x</sub> [N]	F <sub>y</sub> [N]	F <sub>z</sub> [N]
KCH/...	110	680	680	2.150	6.500	6.000

The dynamic values indicated do not correspond to maximum theoretical load capacities. They already take safety factors into account which are suitable for machinery in the automation sector. In the event of combined stress consult the technical support service.

Choice of beam depending on availability between supports.

**Constructive data**

Belt	32AT10
Sliding	4 ball slides [mm]
Profile	50 x ...
Pulley Ø	70,03 [mm]
Linear displacement per revolution	220 [mm]
Colour	natural anodisation

**Weights**

Inertia of the pulley	-	[kgm <sup>2</sup> ]
Belt weight	0,38	[kg/m]
Carriage weight	2,2	[kg]
Base module (stroke=0)	M <sub>base</sub> = 9	[kg]
1.000 mm profile	q=3 + profile	[kg]

To calculate the module weight use the following formula:  $M = M_{base} + q \cdot \text{Stroke}_{max} / 1.000 \text{ Stroke}_{max} \text{ [mm]}$

Sizes available

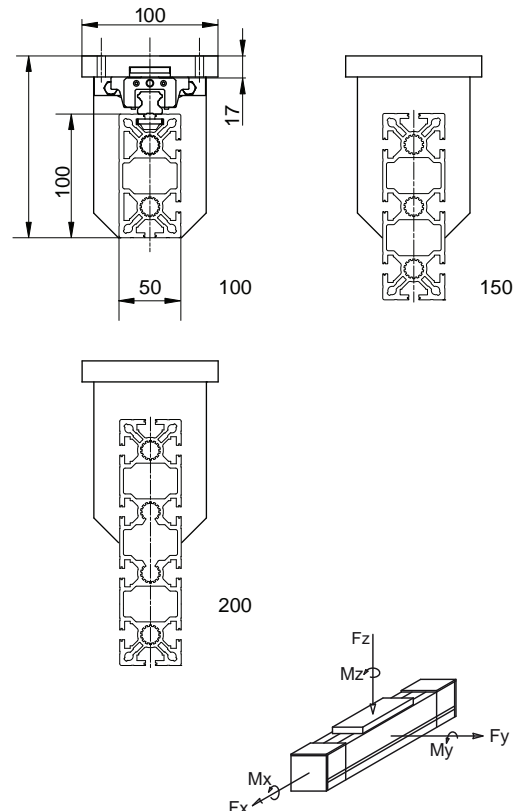

F<sub>x</sub> = Max belt strenght



# Drive Pulley Bores for Shrink Discs

Registered model

The motor connection is pre-engineered directly on the drive head by means of a removable flange, but integrated in the actual head. The drive shaft and/or the driven shaft are locked into the pulley by shrink-discs. (The gearbox can be easily removed without disassembling the head). Please see page ML-6 to identify the desired motor side (left or right); page ML-61 for shrink-disc and flange diameter and page ML-10 for the order code setting. Non-standard diameters are available upon request.

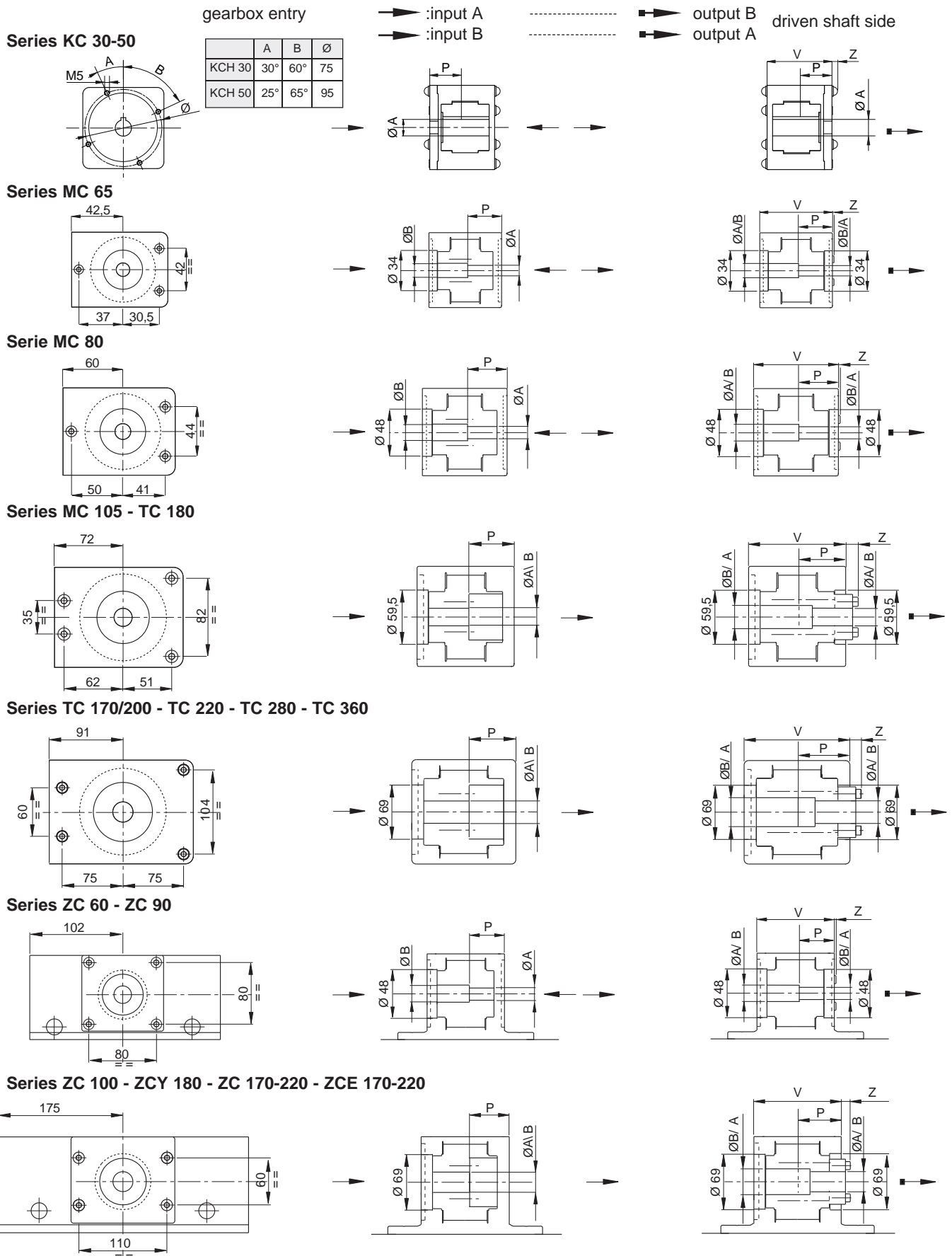

Module	A Ø [mm]	B Ø [mm]	V [mm]	P [mm]	Z [mm]
MC 65 - TC 100	12H7		67	34	0
		14H7	67	34	0
MC 80	16H7		80	52.4	1
		19H7	80	49.4	1
		20H7	80	49.4	1
MC 105 - TC 180	19H7		105	49	13.5
		25H7	105	51	8
TC 170 - TC 200	25H7		117	54.5	12.5
		32H7	117	57.5	7
TC 220 - TC 280 - TC 360	25H7		142	79.5	12.5
		32H7	142	82.5	7
		40H7	142	82.5	7
ZC 60 - ZC 90	16H7		100	62.4	0
		19H7	100	62.4	0
		20H7	100	62.4	0
ZC 100 - ZCY 180	25H7		108	48.5	11.5
		32H7	108	52.5	6
		25H7	108	48.5	11.5
ZC 170 - 220		32H7	108	52.5	6
		40H7	108	52.5	6
	25H7		143	65	12
ZCE 170 - 220		32H7	143	95	12
		40H7	143	95	12

Phosphating of drive and driven pulleys.

## Adapter Flanges

Standard machining for planetary gearboxes - MP or MPTR, LP, EP series.

Machining is performed directly on the removable flange in a symmetric position, suitable for both sides.

Ex. module: MC 105

Ex. module: TC 280

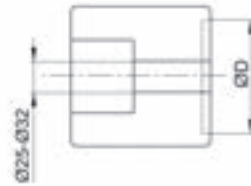
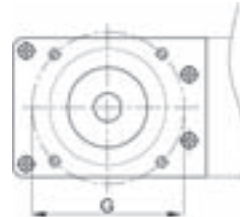
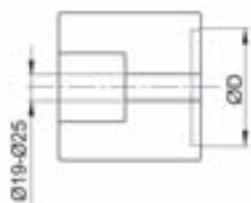

Linear module	Gearbox code	D	Ø	Size
Series		D	Ø	G
MC 65	LP 050	35	12	44
KC 30-50	EP55	32	12	40
	MP053	32	12	40
MC 80-105 - ZC 60	MPTR080	50	19	65
	LP070	52	16	62
ZC 90	EP75 AA	40	14	52
MC 105 - TC-ZC 100 MC 105 - TC 180	MPTR105	70	25	85
	LP090	68	22	80
	EP90 TT	50	19	65
TC 170-360 ZC 170-220	MPTR130	80	32	110
	LP120	90	32	108
	EP120 TT	70	25	85

Drilled flange: code E  
Blind flange: code X

# Connecting shafts for parallel modules

We can supply standard hollow shaft connections, according to your application requirements. Please specify the type of module to be connected, together with speed, "L" centre-distance, working and peak torques, accuracy.  
Some simplified solutions with solid shafts are available for low-speed applications and with "L" of up to 2,000 mm. If high-speeds and/or "L" of more than 2,000 mm are needed, please ask our technical dept. for the shaft scaling.

**The complete kit includes all the components needed to make the connection: tube, shrink-discs, shaft crop ends for connection between pulleys and shrink-discs, any supports.**

Tube material: 6060 aluminium alloy

The customer is responsible for ensuring compliance with accident prevention rules in relation to all rotating parts.

## Type 1 - Elastic joint connecting shafts, normally suitable for low-speeds

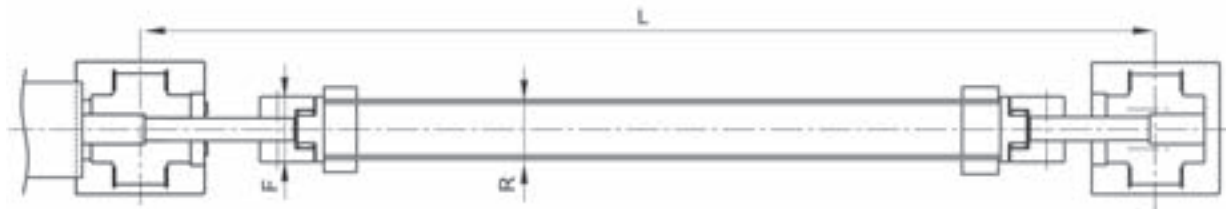

## Type 2 - Stainless steel blade joint connecting shafts, suitable for backlash-free transmissions

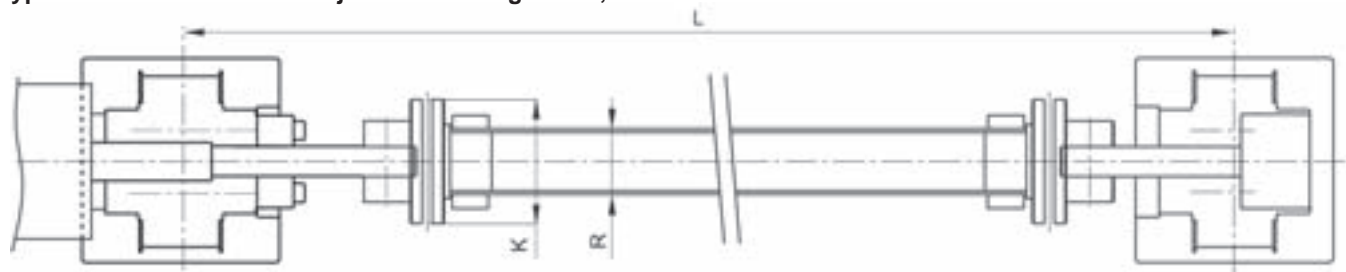

## Type 3 - Stainless steel blade joint connecting shafts and pedestal bearings, suitable for backlash-free transmissions

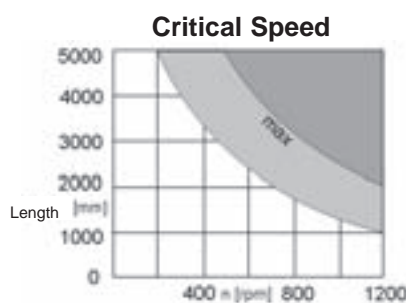
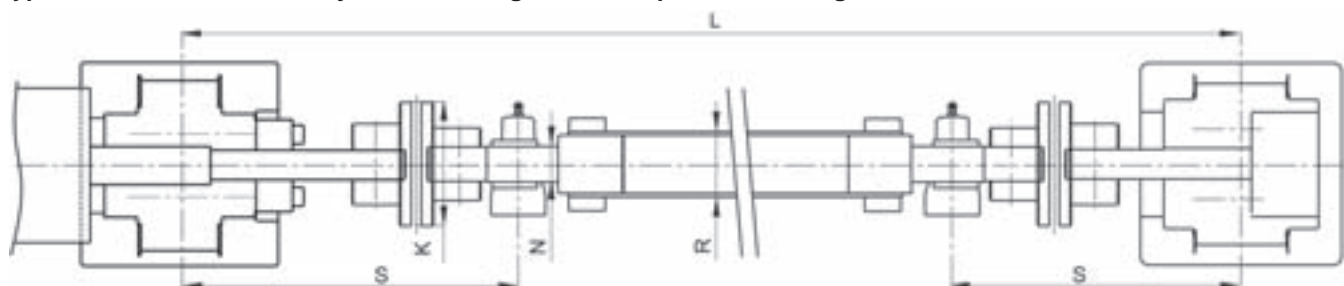

R(*)	K	F	N	S	Lmax	MTwork [Nm]	Mom.Inertia. [Kgm <sup>2</sup> ]	Type 1: Code/L	Type 2: Code/L	Type 3: Code/L
40	67	55	20	200	6,200	20	$0.0028 + 0.46 \times L \times 10^{-6}$	436.0948	436.0957	436.0965
50	81	65	25	235	6,300	35	$0.0092 + 0.66 \times L \times 10^{-6}$	436.0949	436.0958	436.0966
50	93	80	25	235	6,300	70	$0.0161 + 1.34 \times L \times 10^{-6}$	436.0951	436.0971	436.0974
70	104	95	25	235	6,400	100	$0.0293 + 2.93 \times L \times 10^{-6}$	436.0952	436.0960	436.0968
80	126	120	25	250	6,400	190	$0.0793 + 4.5 \times L \times 10^{-6}$	436.0955	436.0963	436.0984
90	143	-	-	-	6,500	300	$0.1456 + 6.53 \times L \times 10^{-6}$	-	436.0986	436.0987
110	185	-	-	-	6,000	420	$0.3499 + 12.3 \times L \times 10^{-6}$	436.0144	436.0145	436.0146

The S value can vary by  $\pm 20\%$ , Lmax by  $\pm 3\%$ , according to the chosen type. Please contact our technical dept.

### Spare rollers with pins

Make sure that all the components are locked in place with the appropriate screws. The recommended tightening torque for pin locking screws and nuts is 50 Nm.



#### Max. load factors for hardened and tempered guides

Roller	Cw [N]	C0w[N]	Fr amm.[N]	V max.
Ø30	5,000	3,000	1,350	7 m/s
Ø40	9,800	6,200	2,600	7 m/s
Ø52	15,800	10,500	4,400	6 m/s
Ø62	21,100	14,500	5,600	5 m/s

#### Max. load factors for hardened guides

Roller	Cw [N]	C0w[N]	Fr amm.[N]	V max.
Ø30	5,000	3,000	400	2 m/s
Ø40	9,800	6,200	800	13 m/s
Ø52	15,800	10,500	1,400	2.5 m/s
Ø62	21,100	14,500	1,900	2 m/s

#### Spare roller with pin

Spare roller with pin	Weight [kg]	Code
Ø30 Concentric	0.02	<b>406.0056</b>
Ø40 Concentric	0.22	<b>205.0464</b>
Ø40 Eccentric (± 0.75 mm)	0.25	<b>205.0463</b>
Ø52 Concentric	0.4	<b>205.0163</b>
Ø62 Concentric	0.55	<b>205.0165</b>

### Mounting brackets

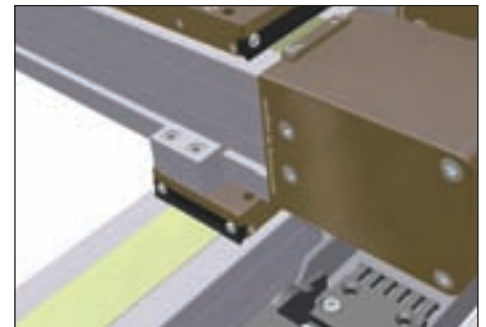
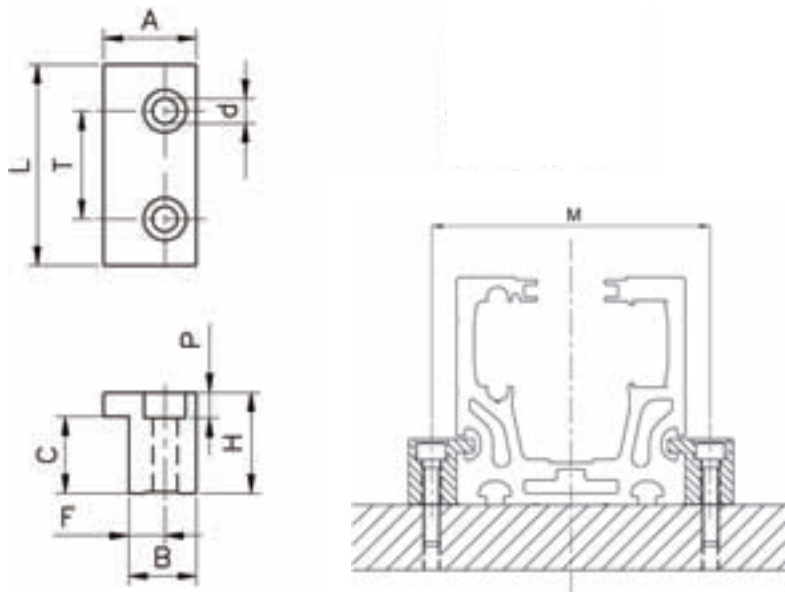

**Material:** aluminium alloy 6082

Module type	bxh	A	L	T	d	H	P	C	F	B	M	Code
MC 65	67x65	25	50	25	6.7	20	6.8	13.5	10	18	87	<b>415.0388</b>
MC 80	80x80	25	50	25	6.7	25	6.8	18.6	10	18	100	<b>415.0760</b>
TC-ZC 100		25	50	25	6.7	27	6.8	20.6	10	18	120	<b>415.0764</b>
MC 105	105x105	30	50	25	9	30	9.5	23.6	12	22	129	<b>415.0761</b>
TC 180	180x90	30	50	25	9	25	9.5	18	12	25	204	<b>415.0773</b>
TC 170	120x170										198	
TC 200	120x200	30	90	50	11	40	11	28.3	14	25	228	<b>415.0762</b>
TC 220	120x220										248	
TC 280	170x280	30	90	50	11	20	11	11.3	14	25	308	<b>415.0763</b>
TC 280Vert. 280x170		30	90	50	11	20	11	13.5	14	25	198	<b>915.1174</b>

# Accessories and screws

## Assembly brackets

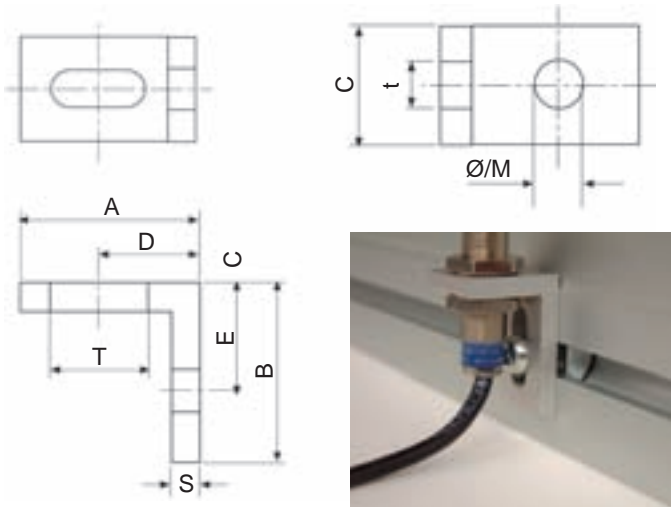

**Material:** natural, anodised anticorrosion alloy.

Thread							Code			
A	B	C	D	E	S	Txt	ØM	Ø	M	
45	45	20	25	25	5	20x6.5	6	<b>A30-76</b>	<b>A 30-86</b>	
35	25	20	19	15	5	20x6.5	4	<b>A30-54</b>	<b>A 30-64</b>	
35	25	20	19	15	5	20x6.5	5	<b>A30-55</b>	<b>A 30-65</b>	
35	25	20	19	15	5	20x6.5	6	<b>A30-56</b>	<b>A 30-66</b>	
25	25	15	14	15	4	13.5x5.5	3	<b>B30-53</b>	<b>B 30-63</b>	
25	25	14	14	15	4	13.5x5.5	4	<b>B30-54</b>	<b>B 30-64</b>	
25	25	15	14	15	4	13.5x5.5	5	<b>B30-55</b>	<b>B 30-65</b>	
25	25	15	14	15	4	13.5x5.5	6	<b>B30-56</b>	<b>B 30-66</b>	

Suitable for all the modules

## Filler strips

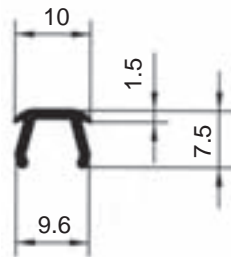

PVC filler strips, grey or black L=5,000 - 6,000 mm  
for any longitudinal 8 mm slot

Suitable for series: **MC 80-105, ZC 60-90-100-170, TC 100-180**

Color	Code A /Length
grey	<b>Cod.A39-25/5000</b>
black	<b>Cod.A39-26/5000</b>
orange (on request)	<b>Cod.A39-25/6000 A</b>

## Spring nut

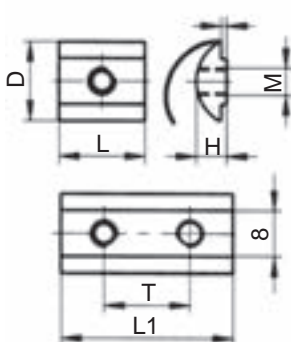
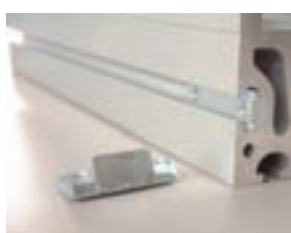

Plate suitable for every kind of module (8 mm slot).  
Material: nut in galvanised steel welded to the harmonic steel spring. The B series can also be inserted through the slot.

Code A: MC 80-105, ZC 60-90-100-170, TC 100-180  
Code B: MC 65



Single plate	Code A	Code B
M5	A32-55	B32-55
M6	A32-65	B32-65
M8	A32-85	B32-85

Double plate	Code A	Code B
M6	A32-67	B32-67

Size					
Base Module	D	H	L	L1	T
MC 105, ZC 100	14	7.8	20	40	30
MC 80	11	4.1	20	40	30

## Simple nut

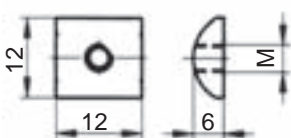

Material: galvanised steel.  
Insert through the end of the profile.  
Suitable for series:

MC 80-105, ZC 60-90-100-170, TC 100-180

Thread	Code
M5	209.2431
M6	209.2432
M8	209.2433

## Front insertable spring nut

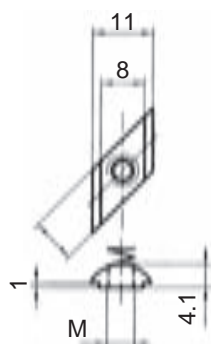
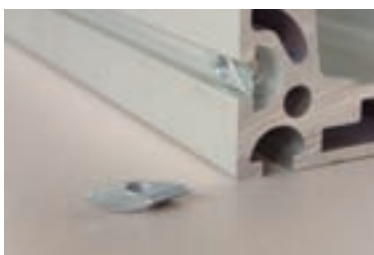

Material: galvanised steel, harmonic steel spring.  
To be inserted through the slot.  
Suitable for series:

MC 65

Thread	Code B
M3	BD31-30
M4	BD31-40
M5	BD31-50
M6	BD31-60

## Simple Nut

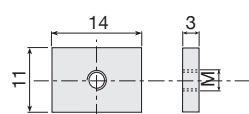
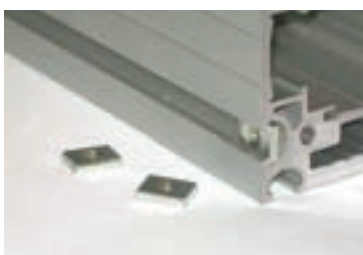

Material: galvanised steel.  
To be inserted through the slot. Suitable for series:

MC 65

Thread	Code B
M4	B32.40
M5	B32.50
M6	B32.60



# Threaded nuts and plates

## Flat nut

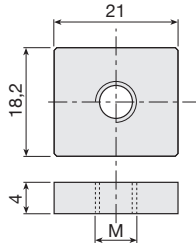
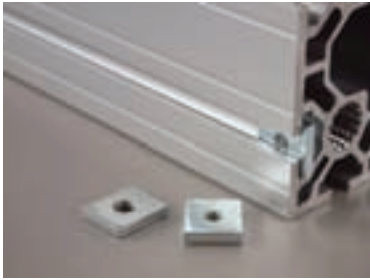

**Material:** galvanised steel.  
Insert through the end of the profile.  
Retaining spring upon request.

**TC-ZC 100, TC 180, ZCY 180**

Thread	Code
M4	A32-40
M5	A32-50
M6	A32-60
M8	A32-80
Molla	211.1061

## Semi-rounded threaded inserts with spring

Threaded plate for base profile 45, 50 and 60. Material: galvanised steel.  
Important: to be inserted through the longitudinal slots before assembling.

Suitable for series:  
**TC-ZC 100, ZCY 180, TC 170-180-200-220-360, ZC 170-220**

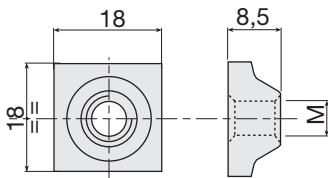

Thread	Code 18x18	Code 20x20
M4	209.0031	209.0023
M5	209.0032	209.0019
M6	209.0033	209.1202
M8	209.0034	209.0467

Plastic compound spring for vertical positioning of insert.

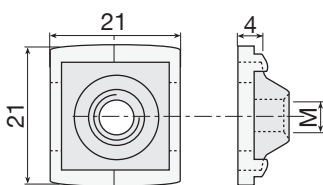

Spring	Code
Suitable for all inserts 18x18	101.0732

## Nuts for steel guide rails

**Material:** galvanised steel.

### Code 209.1855

Alignment nuts.  
V-shaped guide rail: 35x16  
Profile with slot. 12.5 mm.  
Series: **TC 170-200-220-280-360 e ZC 170-220**

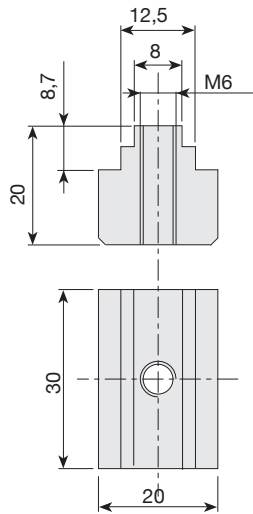
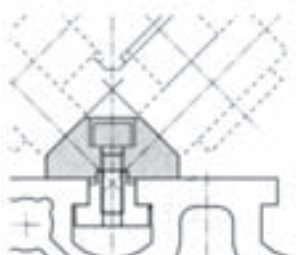

### Code 209.0298

Alignment nuts.  
V-shaped guide rail: 35x16  
Profile with slot 8 mm.  
Series: **TC-ZC 100, TC 180**

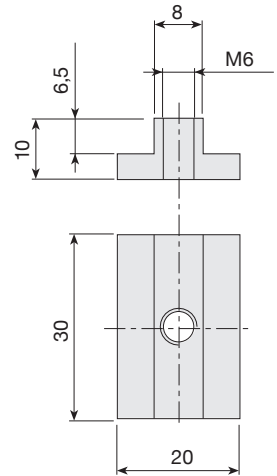
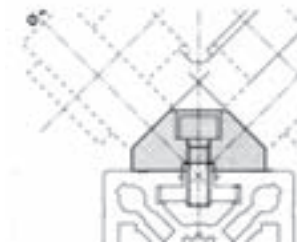

## Alignment nut for slot 12.5 mm



**Material:** galvanised steel. Suitable for series:  
**TC 170-200-280-360 and ZC 170-220**

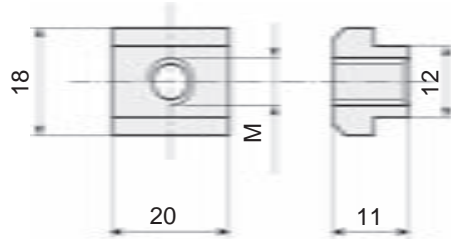

Thread	Code
M5	215.1768
M6	215.1769
M8	215.1770
M10	215.2124

## Alignment nut for slot 12.5 mm front insertable



**Material:** galvanised steel. Suitable for series:  
**TC 170-200-280-360 and ZC 170-220**

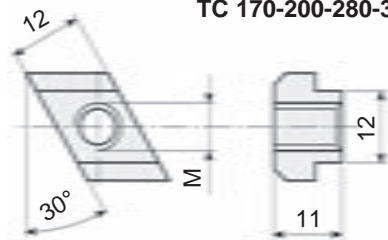

Thread	Code
M5	215.1771
M6	215.1772
M8	215.1773
M10	215.2125

## Threaded nuts and plates

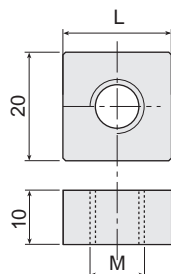

M12 (CH19) hexagonal-head screws can be used as stud bolts in profiles with 12.5 mm slots.

**Material:** galvanised steel. Suitable for series:  
**TC 170-200-220-280-360 and ZC 170-220**

Thread	Type	L	Code
M10	1-hole plate	40	215.0477
M12	1-hole plate	40	209.1281
M10	1-hole plate	20	209.1277
M10	2-holes plate*	80	209.1776
M10	3-holes plate*	150	209.1777
M10	4-holes plate*	200	209.1778
M10	5-holes plate*	250	209.1779
M10	6-holes plate*	300	209.1780
M10	7-holes plate*	350	209.1781

\* Hole centre-distance: 50 mm.

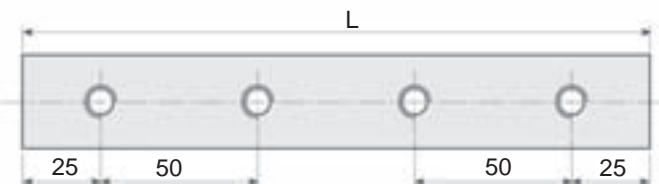



## Micro-switch brackets - application examples



Mechanical and inductive micro-switches on MC series.

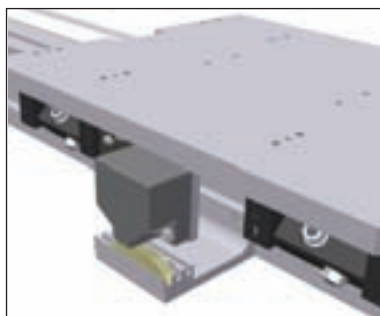

Multi-channel micro-switch on TC series.



Mechanical and inductive micro-switches on MC series.

**Micro-switches and brackets are supplied according to the needs of the application.**

We can also supply cams and cam-holders for mechanical micro-switches in accordance with DIN standards.

## Cams and cam-holders for micro-switches

### Long cams

Cams in accordance with DIN 69639 except when marked "#".  
Material: steel with hardened and ground surface.

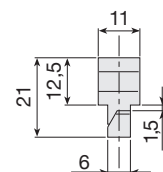
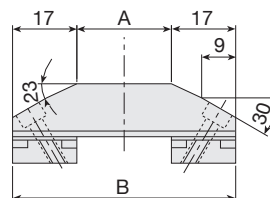

A	B	Code
25	59	<b>211.2132</b>
40	74	<b>211.2133</b>
63	97	<b>211.2134</b>
80 #	114	<b>211.2135</b>
100	134	<b>211.2136</b>

### Short cams

Cams in accordance with DIN 69639  
Material: steel with hardened and ground surface.

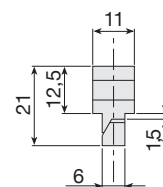
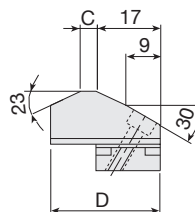

C	D	Code
0	25	<b>211.2128</b>
4	29	<b>211.2129</b>
10	35	<b>211.2130</b>
16	41	<b>211.2131</b>

### Cam-holder guides

Cams in accordance with DIN 6963  
Materiale: lega di alluminio 6060 anodizzato

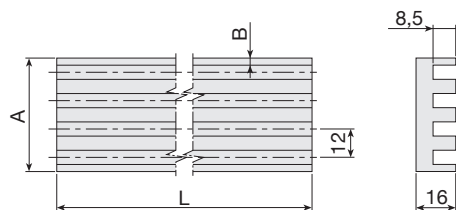
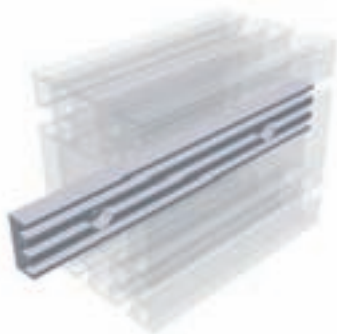

n°	B	A	L	Code
3	3	36	2,000	<b>202.2138</b>
4	5.5	53	3,000	<b>202.2139</b>
6	5.5	77	3,000	<b>202.2140</b>
8	5.5	101	3,000	<b>202.2141</b>

## Reader system with magnetic scale and sensor

The magnetic scale is applied to the body of the module using a supporting and protective profile.  
Precision of between  $\pm 0.015$  and  $\pm 0.05$  mm  
Max speed =  $4 \div 10$  m/s (depending on the type)

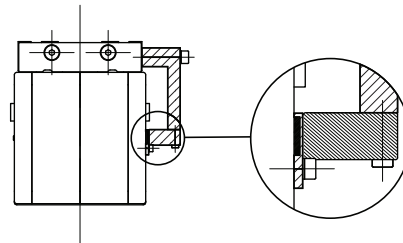

## Twin drive head

Version with drive head on both sides.

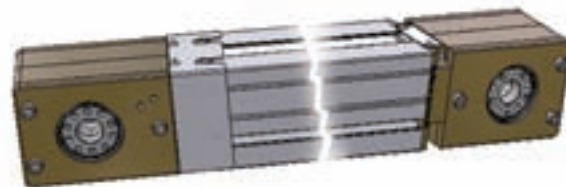
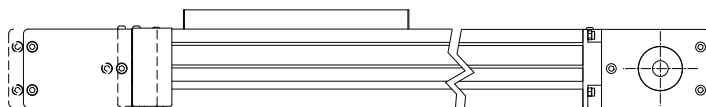

## Precision profile machining

Profiles can be machined along their entire length, to provide the required precision or according to application specifications.

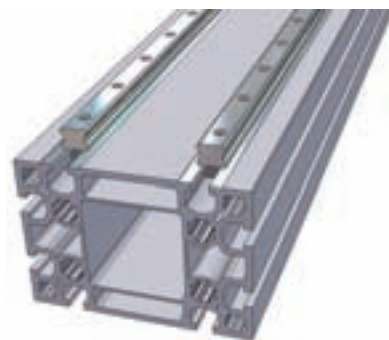
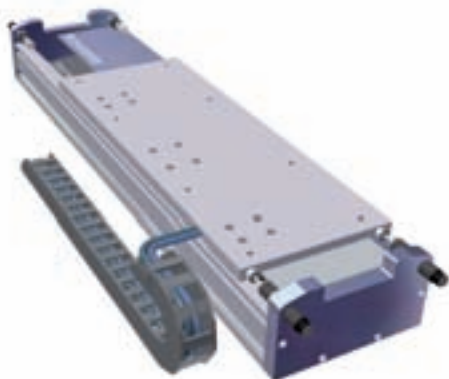

## Rotatable load-bearing profile to fully exploit the moment of inertia

The load-bearing profile can be rotated in order to change the overall dimensions, or to fully exploit the moment of inertia.

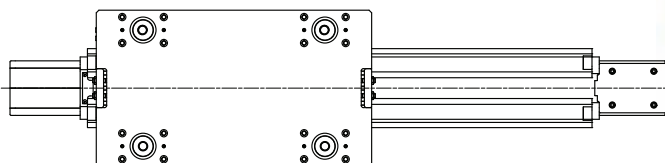
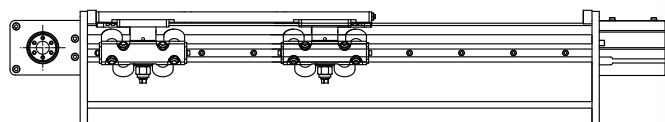
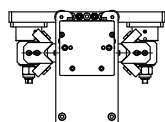

# Special applications

## Belt protection for series MC - 80 - 105

Guard system consisting of a magnetic stainless steel foil to protect the belt from dust and external agents (code: LI), which is attached to the profile.

NB: Avoid the use of a metallic band in the presence of ferrous filings. Optional.

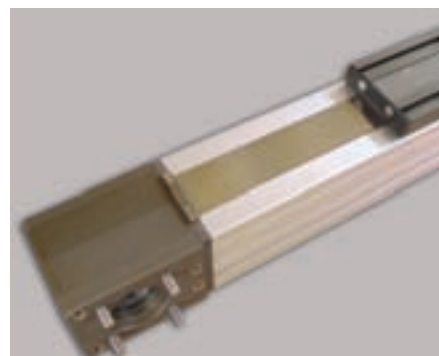
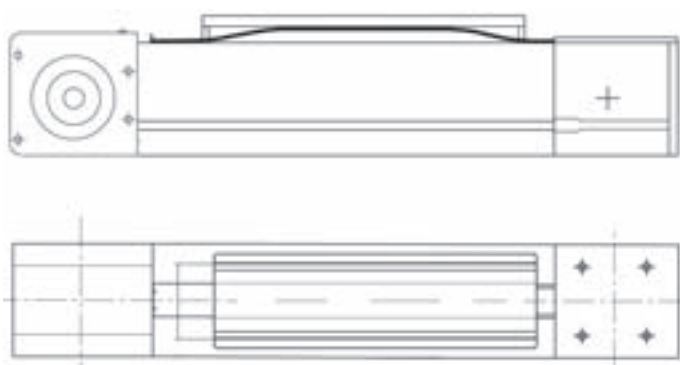

## TC series of linear modules with pulley axis turned at 90°

In some applications which involve the use of high speeds and accelerations, the assembly of linear units having a vertical pulley axis and a centre-distance of more than 4 m may force the toothed belt and result in the need for premature maintenance. In this case we suggest you mount the pulleys and the belt in a horizontal position. The modification as shown in the figure below can be requested for the MODLINE TCS series. Optional.

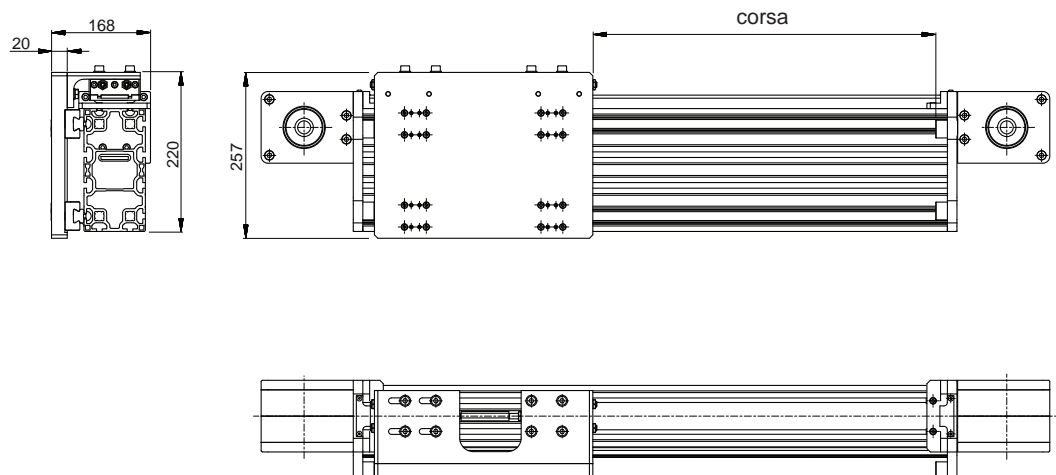

## TC multi-carriage linear modules with intermediate belt transmission

Example of horizontal transfer with integrated belt and transmission pulley support, in an intermediate position, all incorporated inside the profile. **(Registered design)**

Special feature: note the compensating cylinders and the horizontal cylinder for the different travel of carriage no. 3.

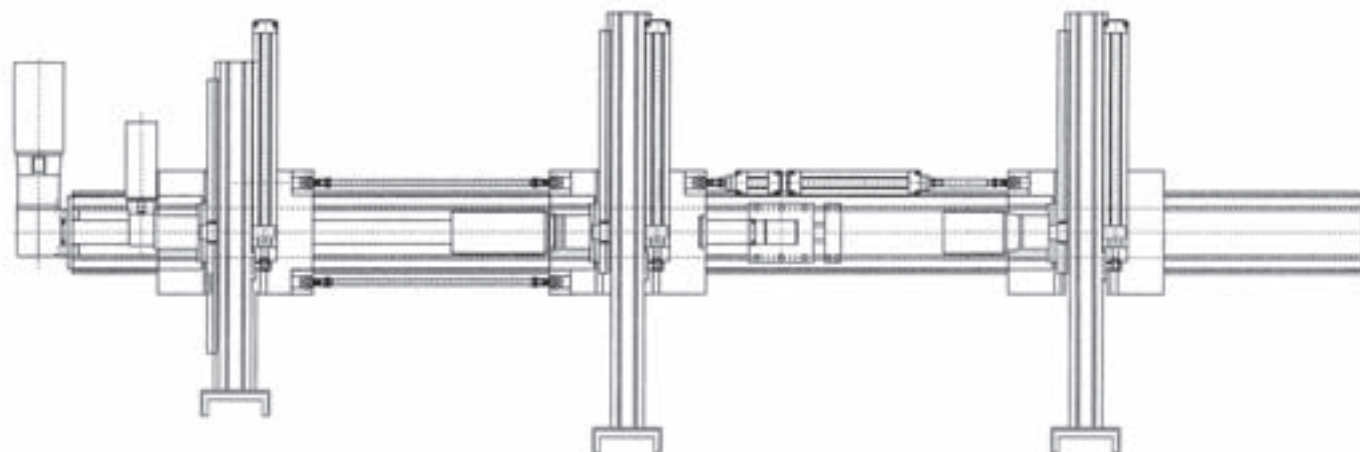

Anti-drop devices, available in a range of sizes, are supplied according to the type of application. For instance, they can act as a mechanical stop to block the free-falling load at any stroke point, or as a lock in static conditions at any position. Two-way blocking occurs following an unexpected pressure drop. A mechanical release system is available upon request (patented). Catalogue available upon request. The kit includes: braking device and rod with relative supports, micro-switch and solenoid valve. Operating pressure 3-6 Bar. With no pressure = locked.

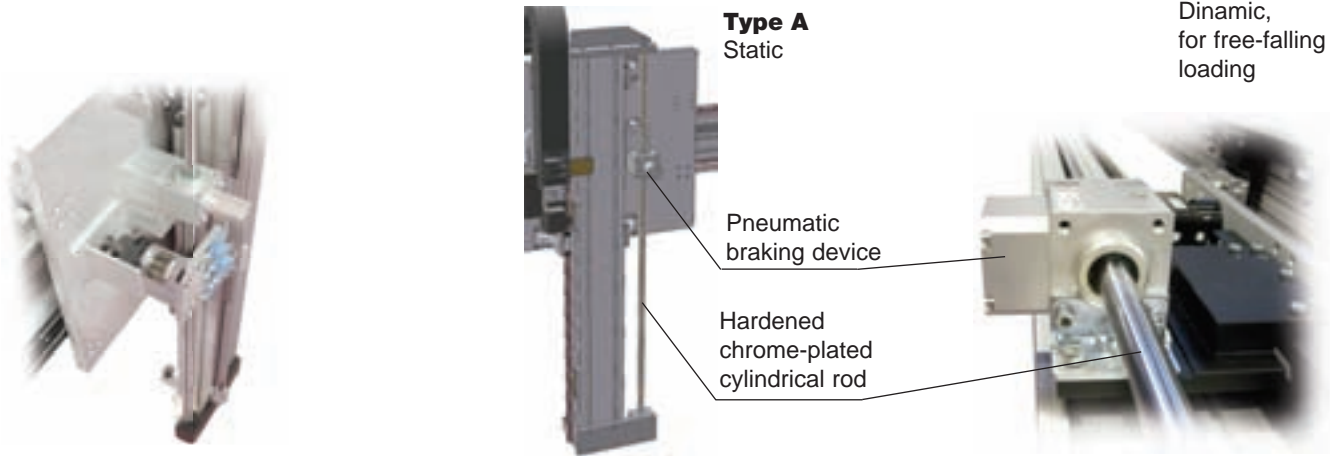

### 1- Static rod blocking device

Type	Code	Rod blocking force [N]	Stroke [mm]
A	236.0018	/ 1,200	/ ...
A	236.0018	/ 1,900	/ ...
A	236.0018	/ 3,000	/ ...
A	236.0018	/ 5,400	/ ...
A	236.0018	/ 7,500	/ ...
A	236.0018	/ 12,000	/ ...

Emergency brake for free-falling load.

### 1- Dynamic rod blocking device

Type	Code	Rod blocking force [N]	Stroke [mm]
B	236.0019	/ 3,000	/ ...
B	236.0019	/ 5,400	/ ...
B	236.0019	/ 7,500	/ ...
B	236.0019	/ 12,000	/ ...

## Lock-pin (stopper cylinders)

Lock-pin devices, available in two sizes, suitable to block the vertical axes in position during horizontal movements. (e.g.: maintenance). The lock-pins are provided with a through rod. Select the size according to the load. The kit includes: drilled plate for rod, stopper cylinder, micro-switch. Max. operating pressure: 10 bar.

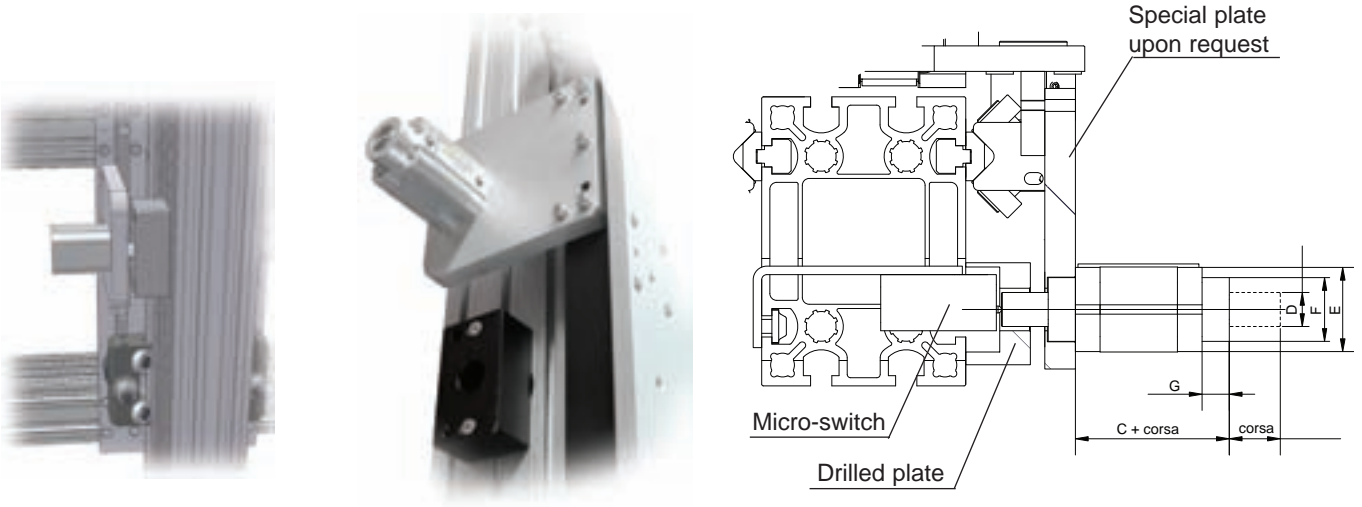

### 1- Lock-pin device

ØD rod	stroke	C	E	F	G	Kit Code
20	20	60.5	50	38	16	236.0021
32	30	-	-	-	-	236.0022

### 2- Accessory: drilled plate for rod

ØD rod	Base	Length	Thickness
20	60	100	39
32	60	100	39

# Index

Code	page	Code	page	Code	page	Code	page	Code	page
1010732	ML-66	2151773	ML-67	A30-65	ML-64	MA1-4	ML-12	TVH 180	ML-26
2022138	ML-68	2152124	ML-67	A30-66	ML-64	MA1-5	ML-12	TVS 170	ML-27
2022139	ML-68	2152125	ML-67	A30-76	ML-64	MCH 105	ML-20	TVS 220	ML-28
2022140	ML-68	2360018	ML-71	A30-86	ML-64	MCH 65	ML-16	ZCEL 170	ML-54
2022141	ML-68	2360019	ML-71	A32-40	ML-66	MCH 80	ML-18	ZCEL 220	ML-56
2050163	ML-63	2360021	ML-71	A32-50	ML-66	MCHH 105	ML-21	ZCERQ 170	ML-53
2050165	ML-63	2360022	ML-71	A32-55	ML-65	MCR 105	ML-19	ZCERQ 220	ML-55
2050463	ML-63	3020001	ML-14	A32-60	ML-66	MCR 65	ML-15	ZCG 60	ML-45
2050464	ML-63	4060056	ML-63	A32-65	ML-65	MCR 80	ML-17	ZCG 90	ML-47
2090019	ML-66	4150388	ML-63	A32-67	ML-65	MCS 105	ML-20	ZCL 100	ML-52
2090023	ML-66	4150760	ML-63	A32-80	ML-66	MCS 65	ML-16	ZCL 170	ML-54
2090298	ML-67	4150761	ML-63	A32-85	ML-65	MCS 80	ML-18	ZCL 220	ML-56
2090467	ML-66	4150762	ML-63	A39-25/5000	ML-64	MTR 105	ML-23	ZCL 60	ML-46
2091202	ML-66	4150763	ML-63	A39-25/6000	AML-64	MTR 80	ML-22	ZCL 90	ML-49
2091277	ML-67	4150764	ML-63	A39-26/5000	ML-64	MVH 105	ML-24	ZCRQ 100	ML-51
2091281	ML-67	4150773	ML-63	B30-53	ML-64	MVHH 105	ML-25	ZCRQ 170	ML-53
2091776	ML-67	4360144	ML-62	B30-54	ML-64	MVR 105	ML-23	ZCRQ 220	ML-55
2091777	ML-67	4360145	ML-62	B30-55	ML-64	MVR 80	ML-22	ZCRR 90	ML-48
2091778	ML-67	4360146	ML-62	B30-56	ML-64	MVS 105	ML-24	ZCY 180	ML-50
2091779	ML-67	4360948	ML-62	B30-63	ML-64	TCG 100	ML-29	ZMCPDLL 105	
2091780	ML-67	4360949	ML-62	B30-64	ML-64	TCG 180	ML-31	ML-57	
2091781	ML-67	4360951	ML-62	B30-65	ML-64	TCH 100	ML-30	ZMCLL 105	ML-57
2091855	ML-67	4360952	ML-62	B30-66	ML-64	TCH 170	ML-34	ZMCH 105	ML-58
2092431	ML-65	4360955	ML-62	B32-40	ML-65	TCH 180	ML-32	KCH 100	ML-59
2092432	ML-65	4360957	ML-62	B32-50	ML-65	TCH 200	ML-36	KCH 150	ML-59
2092433	ML-65	4360958	ML-62	B32-55	ML-65	TCH 220	ML-38	KCH 200	ML-59
2111061	ML-66	4360960	ML-62	B32-60	ML-65	TCH 280	ML-40	TECRQ 170	ML-43
2112128	ML-68	4360963	ML-62	B32-65	ML-65	TCH 360	ML-42	TECH 170	ML-43
2112129	ML-68	4360965	ML-62	B32-67	ML-65	TCRQ 170	ML-33	TECRR 180	ML-44
2112130	ML-68	4360966	ML-62	B32-85	ML-65	TCRQ 180	ML-31	TECH 180	ML-44
2112131	ML-68	4360968	ML-62	B35-15	ML-64	TCRQ 200	ML-35		
2112132	ML-68	4360971	ML-62	BD31-30	ML-65	TCRQ 220	ML-37		
2112133	ML-68	4360974	ML-62	BD31-40	ML-65	TCRQ 280	ML-39		
2112134	ML-68	4360984	ML-62	BD31-50	ML-65	TCRP 280	ML-39		
2112135	ML-68	4360986	ML-62	BD31-60	ML-65	TCRP 360	ML-41		
2112136	ML-68	4360987	ML-62	E01-4	ML-11	TCS 100	ML-30		
2150477	ML-67	7400568	ML-12	E01-5	ML-12	TCS 170	ML-34		
2151768	ML-67	9151174	ML-63	F01-1	ML-11	TCS 180	ML-32		
2151769	ML-67	A30-54	ML-64	M 65X67	ML-11	TCS 200	ML-36		
2151770	ML-67	A30-55	ML-64	M 80X80	ML-11	TCS 220	ML-38		
2151771	ML-67	A30-56	ML-64	M 105X105	ML-11	TCS 280	ML-40		
2151772	ML-67	A30-64	ML-64	MA1-2	ML-12	TCS 360	ML-42		







**ROLLON S.p.A. - ITALY** ▼

Via Trieste 26  
I-20871 Vimercate (MB)  
Phone: (+39) 039 62 59 1  
www.rollon.it - infocom@rollon.it

● Rollon Branches & Rep. Offices  
● Distributors

**Branches:**

**ROLLON GmbH - GERMANY** ▼

Bonner Strasse 317-319  
D-40589 Düsseldorf  
Phone: (+49) 211 95 747 0  
www.rollon.de - info@rollon.de

**ROLLON B.V. - NETHERLANDS** ▼

Ringbaan Zuid 8  
6905 DB Zevenaer  
Phone: (+31) 316 581 999  
www.rollon.nl - info@rollon.nl

**Rep. Offices:**

**ROLLON S.p.A. - RUSSIA** ▼

117105, Moscow, Varshavskoye  
shosse 17, building 1, office 207.  
Phone: +7 (495) 508-10-70  
www.rollon.ru - info@rollon.ru

**ROLLON S.A.R.L. - FRANCE** ▼

Les Jardins d'Eole, 2 allée des Séquoias  
F-69760 Limonest  
Phone: (+33) (0) 4 74 71 93 30  
www.rollon.fr - infocom@rollon.fr

**ROLLON Corporation - USA** ▼

101 Bilby Road. Suite B  
Hackettstown, NJ 07840  
Phone: (+1) 973 300 5492  
www.rolloncorp.com - info@rolloncorp.com

**ROLLON Ltd - UK** ▼

The Works 6 West Street Olney  
Buckinghamshire, United Kingdom, MK46 5 HR  
Phone: +44 (0) 1234964024  
www.rollon.uk.com - info@rollon.uk.com

**Regional Manager:**

**ROLLON Ltd - CHINA** ▼

2/F Central Plaza, No. 227 North Huang Pi Road,  
China, Shanghai, 200003  
Phone: (+86) 021 2316 5336  
www.rollon.cn.com - info@rollon.cn.com

**ROLLON India Pvt. Ltd. - INDIA** ▼

1st floor, Regus Gem Business Centre, 26/1  
Hosur Road, Bommanahalli, Bangalore 560068  
Phone: (+91) 80 67027066  
www.rollonindia.in - info@rollonindia.in

**ROLLON - SOUTH AMERICA** ▼

R. Joaquim Floriano, 397, 2o. andar  
Itaim Bibi - 04534-011, São Paulo, BRASIL  
Phone: +55 (11) 3198 3645  
www.rollonbrasil.com.br - info@rollonbrasil.com

Consult the other ranges of products



Distributor

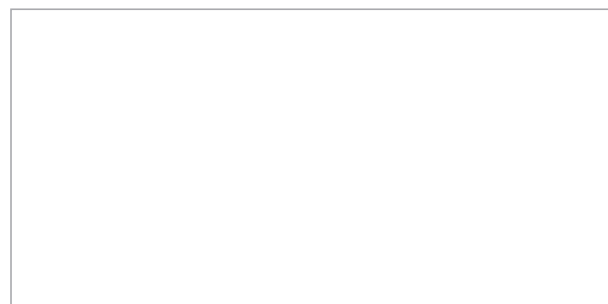

All addresses of our global sales partners can also be found at [www.rollon.com](http://www.rollon.com)