

For New Technology Network

NTN®

NTNcorporation

BEAREE

High Performance Multi-Purpose
Engineering Plastics

CAT. No. 5100-III/E



Warranty

NTN warrants, to the original purchaser only, that the delivered product which is the subject of this sale (a) will conform to drawings and specifications mutually established in writing as applicable to the contract, and (b) be free from defects in material or fabrication. The duration of this warranty is one year from date of delivery. If the buyer discovers within this period a failure of the product to conform to drawings or specifications, or a defect in material or fabrication, it must promptly notify NTN in writing. In no event shall such notification be received by NTN later than 13 months from the date of delivery. Within a reasonable time after such notification, NTN will, at its option, (a) correct any failure of the product to conform to drawings, specifications or any defect in material or workmanship, with either replacement or repair of the product, or (b) refund, in part or in whole, the purchase price. Such replacement and repair, excluding charges for labor, is at NTN's expense. All warranty service will be performed at service centers designated by NTN. These remedies are the purchaser's exclusive remedies for breach of warranty.

NTN does not warrant (a) any product, components or parts not manufactured by NTN, (b) defects caused by failure to provide a suitable installation environment for the product, (c) damage caused by use of the product for purposes other than those for which it was designed, (d) damage caused by disasters such as fire, flood, wind, and lightning, (e) damage caused by unauthorized attachments or modification, (f) damage during shipment, or (g) any other abuse or misuse by the purchaser.

THE FOREGOING WARRANTIES ARE IN LIEU OF ALL OTHER WARRANTIES, EXPRESS OR IMPLIED, INCLUDING BUT NOT LIMITED TO THE IMPLIED WARRANTIES OF MERCHANTABILITY AND FITNESS FOR A PARTICULAR PURPOSE.

In no case shall NTN be liable for any special, incidental, or consequential damages based upon breach of warranty, breach of contract, negligence, strict tort, or any other legal theory, and in no case shall total liability of NTN exceed the purchase price of the part upon which such liability is based. Such damages include, but are not limited to, loss of profits, loss of savings or revenue, loss of use of the product or any associated equipment, cost of capital, cost of any substitute equipment, facilities or services, downtime, the claims of third parties including customers, and injury to property. Some states do not allow limits on warranties, or on remedies for breach in certain transactions. In such states, the limits in this paragraph and in paragraph (2) shall apply to the extent allowable under case law and statutes in such states.

Any action for breach of warranty or any other legal theory must be commenced within 15 months following delivery of the goods.

Unless modified in a writing signed by both parties, this agreement is understood to be the complete and exclusive agreement between the parties, superceding all prior agreements, oral or written, and all other communications between the parties relating to the subject matter of this agreement. No employee of NTN or any other party is authorized to make any warranty in addition to those made in this agreement.

This agreement allocates the risks of product failure between NTN and the purchaser. This allocation is recognized by both parties and is reflected in the price of the goods. The purchaser acknowledges that it has read this agreement, understands it, and is bound by its terms.

©NTN Corporation. 1998

Although care has been taken to assure the accuracy of the data compiled in this catalog, NTN does not assume any liability to any company or person for errors or omissions.

BEAREE Products

NTN High Performance Multi-Purpose Engineering Plastics

High performance sliding bearings, mechanical parts and materials use state-of-the-art engineering plastics.

Products of NTN Engineering Plastics Corporation can be purchased from NTN Corporation and NTN Bearing Corporation. Contact our nearest branch office, sales division or representatives.



1 **Material Grades of NTN Engineering Plastics**

2 **Features of NTN Engineering Plastics**

3 **NTN Engineering Plastics Material Standard Dimensions**

4 **Introduction of Materials and Products for Applications**

5 **Materials for Bearing Applications**

6 **Design and Selection for Bearing Applications**

7 **Technical Reference**

8 **Application Examples**

Material Grades of NTN Engineering Plastics 6

6 ~ 8

Series of standard sliding bearings 9
 Boundary dimensions of AR and ARF10
 Boundary dimensions of BR and TW11
 Boundary dimensions of ML12
 Boundary dimensions of MLC14
 Boundary dimensions of MLCF16
 Boundary dimensions of MLCW16

9 ~ 17

Material standard dimensions18
 Sheet materials19
 Rod materials20
 Pipe materials21

18 ~ 21

4-1 Sliding materials for general purpose22
 4-2 Sliding materials for soft mating materials23
 4-3 Sliding materials for use in water or chemicals24
 4-4 Materials for food processing equipment25
 4-5 Rubber with sliding capability26
 4-6 NBR rubber with sliding capability : BEAREE ER320027
 4-7 Sliding materials with electrical conductivity28
 (Preventing electrostatic charges)
 4-8 Sliding materials for high contact pressures29

4- 9 Sliding materials for use in machine tools : BEAREE FL 3305 ...30
 4-10 Plastics materials for gears31
 4-11 Material for separating pins31
 4-12 Sliding materials for the guide roller32
 4-13 Seal materials for sliding applications33
 4-14 Sound damping material for curtain walls34
 4-15 Sliding materials for bridges and anti-earthquake structures ...35
 4-16 Compound products36
 4-17 Coating materials37

22 ~ 37

5-1 Features of grades and typical characteristic values38
 5-2 Chemical characteristics45

38 ~ 45

6-1 Selection of bearing material (*PV* value)46
 6-2 Estimation of wear46
 6-3 Fits and clearance47
 6-4 Handling49

46 ~ 49

7-1 Design guideline for sliding performance parts50
 7-2 Temperature and allowable area pressure51
 7-3 Friction coefficient52
 7-4 Specific wear ratio53
 7-5 Thermal expansion factor54
 7-6 Test data55

50 ~ 57

58 ~ 63

Confirmation sheet of conditions for use can be found on the last page for your convenience.

Low friction and lubrication free materials provide longer life, lighter weight and other benefits for

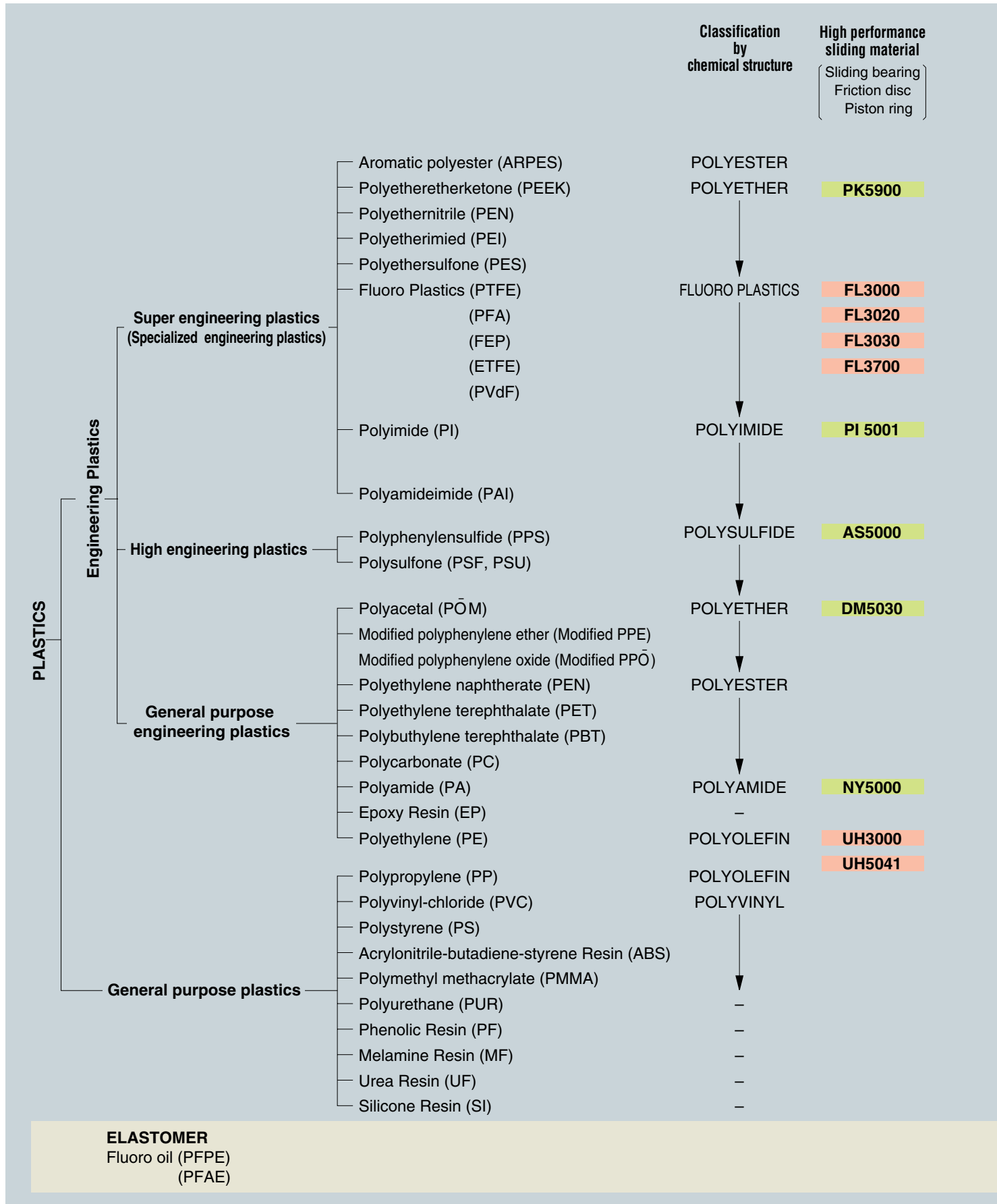

a variety of high technology uses

- Materials for machining
- Injection molding materials
- Coating materials

For soft mating material (Aluminum etc.) (Sliding bearing Seal ring)	For sliding under water and chemical liquid (Sliding bearing Hot water pump bearing)	For specialized application (Electric conductivity Reinforced with bronze mesh Food contact machinery)	For seal ring (Compressor)	Gear materials (Heat insulating sleeve Bearing Bearing cage Lens holder)	For picker finger	Coating materials (Picker finger Roots pump rotor)
---	--	---	-------------------------------	--	-------------------	--

					LC5020	
PK5300		PK5030	PK5300			
						FL7060
FL3030	FL3700	FL3060	FL3000			FL7075
FL3040		FL3305	FL3030			FE7010
FL3050		FL3642	FL3050			FE7030
		FL3900	FL3070			FE7080
		FL9000	FL3900			FE7092
		PI 5001		PI 5030	PI 5022	PI 7000
PI 5010		PI 5040		PI 5033		
				AI 5003	AI 5003	
AS5000	AS5700	AS5910	AS5001	AS5040	AS5021	
AS5005		AS5950	AS5700	AS5044	AS5025	
AS5053		AS5961		AS5045		
DM5030						
		NY5910		NY5010		
		NY5911		NY5910		
		UH3000				
		UH3954				
		UH5000				
		UH5043				

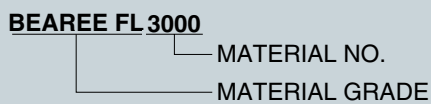

ER3000, ER3600

Table 1 Base Resins and Characteristics of Major Grades

[]: Molding method

Grade	Base Resin	Characteristics
BEAREE FL	Fluoro Plastics (Tetrafluoroethylene)	The base resin of BEAREE FL is a Fluoro plastic with excellent characteristics such as low friction, non-stick quality, and resistance to wear, heat, chemicals, and weather. Special additives are used in BEAREE FL to ensure the best performance in sliding applications. (Compression molding, extrusion, and coating)
BEAREE FE	Fluoro Plastics (other than Tetrafluoroethylene) Fluoro oil	The performance of BEAREE FE is slightly lower than that of BEAREE FL, but it has better productivity. It is excellent for low friction and wear resistance, and is suitable for an antistick coating material. (Injection molding, extrusion, and coating)
BEAREE PI	Polyimide	BEAREE PI has excellent heat resistance and mechanical strength. This material has special fillers to improve the properties of polyimide, which is known as the highest heat-resistant plastic. Thermosetting and thermoplastic types are available, and selected by the application. The high water absorption of this type should be taken into consideration in product design. (Injection molding, extrusion, compression molding and coating)
BEAREE AI	Polyamideimide	Heat resistance of BEAREE AI is slightly lower than BEAREE PI, however it has excellent mechanical properties such as shock and fatigue resistance. The high water absorption of this type should be taken into consideration in product design. (Injection molding, extrusion, compression molding and coating)
BEAREE UH	Polyethylene	This material has lower performance than the “super” engineering plastics; however, this material takes advantage of the excellent properties of polyethylene, such as low friction, high resistance to wear, chemicals, and shocks, non-stick quality, and good electrical properties. The shrinkage factor during molding and coefficient of thermal expansion are high, and the material is difficult to bond. (Injection molding, extrusion, and compression molding)
BEAREE AS	Polyphenylsulfide	BEAREE AS is widely applicable because its base resin of polyphenylsulfide has excellent heat and wear resistance, mechanical properties and moldability. Also, this material is suited for cost effective mass production. (Injection molding)
BEAREE LC	Aromatic polyester	This material has excellent heat resistance and mechanical strength, especially rigidity. When used with materials based on liquid crystal polymer designers should consider the anisotropy of the material at product design. (Injection molding)
BEAREE PK	Polyetheretherketone	BEAREE PK is based on polyetheretherketone, which has excellent properties close to polyimide in heat, chemical, shock and fatigue resistance, and self lubrication. Therefore, the characteristics of this material is similar to BEAREE PI and AI, however water absorption is less. It should be noted at product design that the shrinkage factor at molding is high. (Injection molding and extrusion)
BEAREE NY	Polyamide	This material is based on polyamide, one of the most popular general purpose engineering plastics, and is superior in shock and wear resistance. The heat resistance of this material is lower than “super” engineering plastics, however, it is much more economical. It should be noted at product design that the shrinkage factor at molding is high. (Injection molding)
BEAREE DM	Polyoxymethylene (Polyacetal)	This material is based on polyoxymethylene that is superior in fatigue, creep and wear resistance and dimensional stability; however, because of the high levels of oxygen in the molecular structure, fire retardance is difficult. Like BEAREE NY, this material is much more economical than “super” engineering plastic based materials. (Injection molding)
BEAREE ER	Elastomer (“Sliding Rubber”)	BEAREE ER is based on an elastomer. This “Sliding Rubber” is a fluoro plastic with elasticity and is superior in elasticity, non stick quality, low friction and resistance to heat, wear and creep.

Products using materials such as BEAREE PI, BEAREE AI, BEAREE LC and BEAREE PK are considered strategic products as defined by the "Foreign Exchange and Trade Control Law" in specified use and figure. When exporting a product that comes under the regulation, an export license by the Japanese government is requested. Contact us for details.

The following six series of standard bearings are prepared for a wide variety of applications.

Type AR [Sleeve Bearing]

AR series is machined from a bar or pipe made of BEAREE FL 3000 material.

This bearing only carries radial load and the standard bore size is $\phi 3$ to $\phi 50$ mm.



Type ARF [Flanged Sleeve Bearing]

Type ARF adds a flange to type AR and can carry radial and axial load. The standard bore size is $\phi 3$ to $\phi 50$ mm.



Type BRF [Flanged Sleeve Bearing]

Type BRF is made by injection molding and its material is BEAREE AS 5005. This bearing is flanged to carry radial and axial load. The standard bore size is $\phi 3$ to $\phi 25$ mm. Lighter weight and more compact designs than with the ARF type are possible.



Type TW [Thrust Washer]

The Type TW thrust washer is made from BEAREE FL 3000 tape, the thickness is 0.8mm and standard bore is $\phi 6$ to $\phi 50$ mm.



Type ML [M Liner bearing]

Type ML is a rolled steel plate bushing with BEAREE FL 3060 liner bonded on its bore, and the steel plate is zinc coated for rust prevention. This bearing carries higher pressure than types AR or ARF, having a thin wall, and a more compact design is possible. The standard bore size is $\phi 3$ to $\phi 70$ mm and several widths are available for each bore.



MLC TYPE [MLC bearing]

The MLC type is a three layered bearing composed of a special filler containing tetrafluoroethylene impregnated on the porous sintered layer made of bronze powder sintered on the back metal steel plate. The MLC Bearing for radial loads, the flanged MLCF bearing that can accept radial and axial loads, and thrust load MLCW bearings are standardized.



1. BEAREE FL can be deformed or scratched by shock load, etc. and BEAREE PI can be cracked or chipped.
2. Surface roughness of the mating material greatly affects bearing life. NTN recommends surface roughness of 0.1-0.8Ra.
3. The operating temperature may loose the clearance in the shaft and result in overheating, burning and seizing of the mechanism. Completely check the relation between fittings and clearances before application.

Dimensions to be measured at 25°C

Type AR

Sleeve Bearing

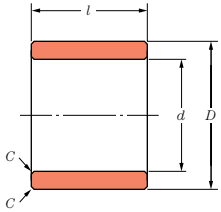

Part No.	Dimension mm				Recommended Fit mm		Minimum Mounted Clearance mm
	d tolerances	D tolerances	l tolerances	C	Shaft h6	Housing M7	
R-AR0305	3 ^{+0.21} / _{+0.16}	6 ^{+0.09} / _{+0.04}	5 ⁰ / _{-0.20}	0.3	3 ⁰ / _{-0.006}	6 ⁰ / _{-0.012}	0.06
R-AR0406	4 ^{+0.21} / _{+0.16}	7 ^{+0.09} / _{+0.04}	6 ⁰ / _{-0.20}	0.3	4 ⁰ / _{-0.006}	7 ⁰ / _{-0.015}	0.06
R-AR0506	5 ^{+0.21} / _{+0.16}	8 ^{+0.09} / _{+0.04}	6 ⁰ / _{-0.20}	0.3	5 ⁰ / _{-0.008}	8 ⁰ / _{-0.015}	0.06
R-AR0608	6 ^{+0.21} / _{+0.16}	9 ^{+0.09} / _{+0.04}	8 ⁰ / _{-0.20}	0.3	6 ⁰ / _{-0.008}	9 ⁰ / _{-0.015}	0.06
R-AR0708	7 ^{+0.23} / _{+0.18}	11 ^{+0.10} / _{+0.05}	8 ⁰ / _{-0.20}	0.5	7 ⁰ / _{-0.009}	11 ⁰ / _{-0.018}	0.06
R-AR0808	8 ^{+0.23} / _{+0.18}	12 ^{+0.10} / _{+0.05}	8 ⁰ / _{-0.20}	0.5	8 ⁰ / _{-0.009}	12 ⁰ / _{-0.018}	0.06
R-AR0910	9 ^{+0.23} / _{+0.18}	13 ^{+0.10} / _{+0.05}	10 ⁰ / _{-0.25}	0.5	9 ⁰ / _{-0.009}	13 ⁰ / _{-0.018}	0.06
R-AR1010	10 ^{+0.24} / _{+0.19}	14 ^{+0.10} / _{+0.05}	10 ⁰ / _{-0.25}	0.5	10 ⁰ / _{-0.009}	14 ⁰ / _{-0.018}	0.07
R-AR1210	12 ^{+0.24} / _{+0.19}	16 ^{+0.10} / _{+0.05}	10 ⁰ / _{-0.25}	0.5	12 ⁰ / _{-0.011}	16 ⁰ / _{-0.018}	0.07
R-AR1515	15 ^{+0.27} / _{+0.20}	21 ^{+0.10} / _{+0.05}	15 ⁰ / _{-0.25}	0.5	15 ⁰ / _{-0.011}	21 ⁰ / _{-0.021}	0.08
R-AR1715	17 ^{+0.27} / _{+0.20}	23 ^{+0.10} / _{+0.05}	15 ⁰ / _{-0.25}	0.5	17 ⁰ / _{-0.011}	23 ⁰ / _{-0.021}	0.08
R-AR2020	20 ^{+0.33} / _{+0.21}	26 ^{+0.11} / _{+0.06}	20 ⁰ / _{-0.25}	0.8	20 ⁰ / _{-0.013}	26 ⁰ / _{-0.021}	0.08
R-AR2220	22 ^{+0.33} / _{+0.21}	28 ^{+0.11} / _{+0.06}	20 ⁰ / _{-0.25}	0.8	22 ⁰ / _{-0.013}	28 ⁰ / _{-0.021}	0.08
R-AR2525	25 ^{+0.33} / _{+0.21}	31 ^{+0.11} / _{+0.06}	25 ⁰ / _{-0.25}	0.8	25 ⁰ / _{-0.013}	31 ⁰ / _{-0.025}	0.08
R-AR2830	28 ^{+0.33} / _{+0.21}	34 ^{+0.11} / _{+0.06}	30 ⁰ / _{-0.25}	0.8	28 ⁰ / _{-0.013}	34 ⁰ / _{-0.025}	0.08
R-AR3030	30 ^{+0.33} / _{+0.21}	36 ^{+0.11} / _{+0.06}	30 ⁰ / _{-0.25}	0.8	30 ⁰ / _{-0.013}	36 ⁰ / _{-0.025}	0.08
R-AR3230	32 ^{+0.38} / _{+0.22}	40 ^{+0.11} / _{+0.06}	30 ⁰ / _{-0.25}	1.0	32 ⁰ / _{-0.016}	40 ⁰ / _{-0.025}	0.09
R-AR3535	35 ^{+0.38} / _{+0.22}	43 ^{+0.11} / _{+0.06}	35 ⁰ / _{-0.25}	1.0	35 ⁰ / _{-0.016}	43 ⁰ / _{-0.025}	0.09
R-AR4040	40 ^{+0.38} / _{+0.22}	48 ^{+0.11} / _{+0.06}	40 ⁰ / _{-0.25}	1.0	40 ⁰ / _{-0.016}	48 ⁰ / _{-0.025}	0.09
R-AR4550	45 ^{+0.39} / _{+0.23}	53 ^{+0.11} / _{+0.06}	50 ⁰ / _{-0.25}	1.0	45 ⁰ / _{-0.016}	53 ⁰ / _{-0.030}	0.09
R-AR5050	50 ^{+0.39} / _{+0.23}	60 ^{+0.11} / _{+0.06}	50 ⁰ / _{-0.25}	1.0	50 ⁰ / _{-0.016}	60 ⁰ / _{-0.030}	0.09

Remark 1. Use $1.0 \times 10^{-7} \text{ mm}^3/\text{N}\cdot\text{Em}$ as a guide line for the specific wear rate K .

Dimensions to be measured at 25°C

Type ARF

Flanged Sleeve Bearing

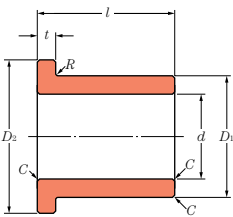

Part No.	Dimension mm					Recommended Fit mm		Minimum Mounted Clearance mm
	d tolerances	D ₁ tolerances	l tolerances	D ₂	t tolerances	Shaft h6	Housing M7	
R-ARF0305	3 ^{+0.21} / _{+0.16}	6 ^{+0.09} / _{+0.04}	5 ⁰ / _{-0.20}	9	1.5 ^{+0.10} / ₀	3 ⁰ / _{-0.006}	6 ⁰ / _{-0.012}	0.06
R-ARF0406	4 ^{+0.21} / _{+0.16}	7 ^{+0.09} / _{+0.04}	6 ⁰ / _{-0.20}	9	1.5 ^{+0.10} / ₀	4 ⁰ / _{-0.008}	7 ⁰ / _{-0.015}	0.06
R-ARF0508	5 ^{+0.21} / _{+0.16}	8 ^{+0.09} / _{+0.04}	8 ⁰ / _{-0.20}	11	1.5 ^{+0.10} / ₀	5 ⁰ / _{-0.008}	8 ⁰ / _{-0.015}	0.06
R-ARF0608	6 ^{+0.21} / _{+0.16}	9 ^{+0.09} / _{+0.04}	8 ⁰ / _{-0.20}	12	1.5 ^{+0.10} / ₀	6 ⁰ / _{-0.008}	9 ⁰ / _{-0.015}	0.06
R-ARF0710	7 ^{+0.23} / _{+0.18}	11 ^{+0.10} / _{+0.05}	10 ⁰ / _{-0.25}	15	2 ^{+0.10} / ₀	7 ⁰ / _{-0.009}	11 ⁰ / _{-0.018}	0.06
R-ARF0810	8 ^{+0.23} / _{+0.18}	12 ^{+0.10} / _{+0.05}	10 ⁰ / _{-0.25}	16	2 ^{+0.10} / ₀	8 ⁰ / _{-0.009}	12 ⁰ / _{-0.018}	0.06
R-ARF0910	9 ^{+0.23} / _{+0.18}	13 ^{+0.10} / _{+0.05}	10 ⁰ / _{-0.25}	17	2 ^{+0.10} / ₀	9 ⁰ / _{-0.009}	13 ⁰ / _{-0.018}	0.06
R-ARF1015	10 ^{+0.24} / _{+0.19}	14 ^{+0.10} / _{+0.05}	15 ⁰ / _{-0.25}	18	2 ^{+0.10} / ₀	10 ⁰ / _{-0.009}	14 ⁰ / _{-0.018}	0.07
R-ARF1215	12 ^{+0.24} / _{+0.19}	16 ^{+0.10} / _{+0.05}	15 ⁰ / _{-0.25}	20	2 ^{+0.10} / ₀	12 ⁰ / _{-0.011}	16 ⁰ / _{-0.018}	0.07
R-ARF1520	15 ^{+0.27} / _{+0.20}	21 ^{+0.10} / _{+0.05}	20 ⁰ / _{-0.25}	27	3 ^{+0.10} / ₀	15 ⁰ / _{-0.011}	21 ⁰ / _{-0.021}	0.08
R-ARF1720	17 ^{+0.27} / _{+0.20}	23 ^{+0.10} / _{+0.05}	20 ⁰ / _{-0.25}	29	3 ^{+0.10} / ₀	17 ⁰ / _{-0.011}	23 ⁰ / _{-0.021}	0.08
R-ARF2025	20 ^{+0.33} / _{+0.21}	26 ^{+0.11} / _{+0.06}	25 ⁰ / _{-0.25}	32	3 ^{+0.10} / ₀	20 ⁰ / _{-0.013}	26 ⁰ / _{-0.021}	0.08
R-ARF2225	22 ^{+0.33} / _{+0.21}	28 ^{+0.11} / _{+0.06}	25 ⁰ / _{-0.25}	34	3 ^{+0.10} / ₀	22 ⁰ / _{-0.013}	28 ⁰ / _{-0.021}	0.08
R-ARF2530	25 ^{+0.33} / _{+0.21}	31 ^{+0.11} / _{+0.06}	30 ⁰ / _{-0.25}	37	3 ^{+0.10} / ₀	25 ⁰ / _{-0.013}	31 ⁰ / _{-0.025}	0.08
R-ARF2830	28 ^{+0.33} / _{+0.21}	34 ^{+0.11} / _{+0.06}	30 ⁰ / _{-0.25}	40	3 ^{+0.10} / _{-0.05}	28 ⁰ / _{-0.013}	34 ⁰ / _{-0.025}	0.08
R-ARF3035	30 ^{+0.33} / _{+0.21}	36 ^{+0.11} / _{+0.06}	35 ⁰ / _{-0.25}	42	3 ^{+0.10} / _{-0.05}	30 ⁰ / _{-0.013}	36 ⁰ / _{-0.025}	0.08
R-ARF3235	32 ^{+0.38} / _{+0.22}	40 ^{+0.11} / _{+0.06}	35 ⁰ / _{-0.25}	48	4 ^{+0.10} / _{-0.05}	32 ⁰ / _{-0.016}	40 ⁰ / _{-0.025}	0.09
R-ARF3540	35 ^{+0.38} / _{+0.22}	43 ^{+0.11} / _{+0.06}	40 ⁰ / _{-0.25}	51	4 ^{+0.10} / _{-0.05}	35 ⁰ / _{-0.016}	43 ⁰ / _{-0.025}	0.09
R-ARF4045	40 ^{+0.38} / _{+0.22}	48 ^{+0.11} / _{+0.06}	45 ⁰ / _{-0.25}	56	4 ^{+0.10} / _{-0.05}	40 ⁰ / _{-0.016}	48 ⁰ / _{-0.025}	0.09
R-ARF4550	45 ^{+0.39} / _{+0.23}	53 ^{+0.11} / _{+0.06}	50 ⁰ / _{-0.25}	61	4 ^{+0.10} / _{-0.05}	45 ⁰ / _{-0.016}	53 ⁰ / _{-0.030}	0.09
R-ARF5060	50 ^{+0.39} / _{+0.23}	60 ^{+0.11} / _{+0.06}	60 ⁰ / _{-0.25}	70	5 ^{+0.10} / _{-0.05}	50 ⁰ / _{-0.016}	60 ⁰ / _{-0.030}	0.09

Remarks 1. The corner radius of flange is 0.2 mm or smaller.

2. Dimensions of chamfer is the same as Type AR for the same bore.

3. The minimum mounting clearance shall be the value when the product is mounted on the M7 ultra strong housing.

4. Use $1.0 \times 10^{-7} \text{ mm}^3/\text{N}\cdot\text{Em}$ as a guide line for the specific wear rate K .

Dimensions to be measured at 25°C

Type BRF

Flanged Sleeve Bearing

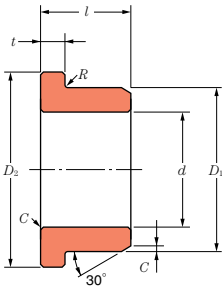

Part No.	Dimension mm					Recommended Fit mm		Minimum Mounted Clearance mm
	d tolerances	D ₁ tolerances	l tolerances	D ₂	t tolerances	Shaft h7	Housing H7	
R-BRF0304	3 ^{+0.21} / _{+0.16}	6 ^{+0.11} / _{+0.06}	4 ±0.2	9	1.5 ±0.1	3 ⁰ / _{-0.010}	6 ^{+0.012} / ₀	0.05
R-BRF0404	4 ^{+0.22} / _{+0.17}	7 ^{+0.12} / _{+0.06}	4 ±0.2	10	1.5 ±0.1	4 ⁰ / _{-0.012}	7 ^{+0.015} / ₀	0.05
R-BRF0505	5 ^{+0.22} / _{+0.17}	8 ^{+0.12} / _{+0.06}	5 ±0.2	11	1.5 ±0.1	5 ⁰ / _{-0.012}	8 ^{+0.015} / ₀	0.05
R-BRF0605	6 ^{+0.22} / _{+0.17}	9 ^{+0.12} / _{+0.06}	5 ±0.2	12	1.5 ±0.1	6 ⁰ / _{-0.012}	9 ^{+0.015} / ₀	0.05
R-BRF0806	8 ^{+0.26} / _{+0.20}	12 ^{+0.14} / _{+0.07}	6 ±0.2	15	2 ±0.1	8 ⁰ / _{-0.015}	12 ^{+0.018} / ₀	0.06
R-BRF1008	10 ^{+0.27} / _{+0.21}	14 ^{+0.14} / _{+0.07}	8 ±0.2	17	2 ±0.1	10 ⁰ / _{-0.015}	14 ^{+0.018} / ₀	0.07
R-BRF1208	12 ^{+0.28} / _{+0.21}	16 ^{+0.14} / _{+0.07}	8 ±0.2	19	2 ±0.1	12 ⁰ / _{-0.018}	16 ^{+0.018} / ₀	0.07
R-BRF1510	15 ^{+0.30} / _{+0.23}	21 ^{+0.15} / _{+0.07}	10 ±0.2	24	3 ±0.1	15 ⁰ / _{-0.018}	21 ^{+0.021} / ₀	0.08
R-BRF2012	20 ^{+0.31} / _{+0.23}	26 ^{+0.15} / _{+0.07}	12 ±0.2	29	3 ±0.1	20 ⁰ / _{-0.021}	26 ^{+0.021} / ₀	0.08
R-BRF2515	25 ^{+0.32} / _{+0.24}	31 ^{+0.16} / _{+0.08}	15 ±0.2	34	3 ±0.1	25 ⁰ / _{-0.021}	31 ^{+0.025} / ₀	0.08

- Remarks 1. Dimension of chamfer is 0.3 mm for 6mm or smaller bore and 0.5mm for 8 mm or larger bore.
 2. The corner radius of flange is 0.2 mm or smaller.
 3. Use $1.5 \times 10^{-7} \text{ mm}^3/\text{N}\cdot\text{Em}$ as a guide line for the specific wear rate *K*.

Dimensions to be measured at 25°C

Type TW

Thrust Washer

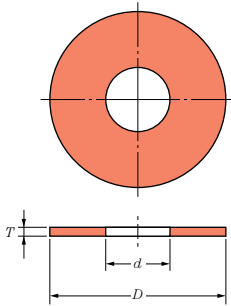

Part No.	Dimension mm		
	d ^{+0.25} / ₀	D ⁰ / _{-0.25}	T ^{±0.06}
R-TW0613	6.2	12.8	0.8
R-TW0715	7.2	14.8	0.8
R-TW0815	8.2	14.8	0.8
R-TW0920	9.2	19.8	0.8
R-TW1020	10.2	19.8	0.8
R-TW1225	12.2	24.7	0.8
R-TW1530	15.3	29.7	0.8
R-TW1735	17.3	34.6	0.8
R-TW2040	20.4	39.6	0.8
R-TW2245	22.4	44.5	0.8
R-TW2550	25.4	49.5	0.8
R-TW2855	28.4	54.4	0.8
R-TW3060	30.4	59.4	0.8
R-TW3260	32.4	59.4	0.8
R-TW3565	35.6	64.3	0.8
R-TW4070	40.6	69.3	0.8
R-TW4575	45.6	74.2	0.8
R-TW5080	50.8	79.2	0.8

Remark 1. Use $1.0 \times 10^{-7} \text{ mm}^3/\text{N}\cdot\text{Em}$ as a guide line for the specific wear rate *K*.

Type ML

M Liner Bearing

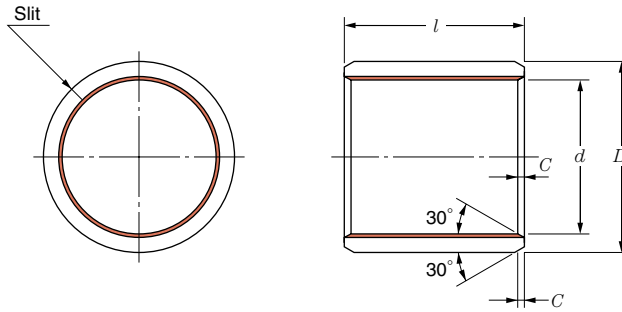

Inner diameter <i>d</i> mm	Outer diameter <i>D</i> mm	Part No.									
		Length <i>l</i> (Tolerances $\begin{smallmatrix} 0 \\ -0.25 \end{smallmatrix}$) mm									
		3	4	5	6	7	8	10	12	15	20
3	5	R-ML0303	R-ML0304	R-ML0305	R-ML0306						
4	6		R-ML0404		R-ML0406		R-ML0408				
5	7		R-ML0504	R-ML0505	R-ML0506		R-ML0508				
6	8			R-ML0605	R-ML0606	R-ML0607	R-ML0608	R-ML0610			
7	9			R-ML0705		R-ML0707		R-ML0710	R-ML0712		
8	10				R-ML0806		R-ML0808	R-ML0810	R-ML0812		
9	11							R-ML0910			
10	12				R-ML1006	R-ML1007	R-ML1008	R-ML1010	R-ML1012	R-ML1015	R-ML1020
12	14				R-ML1206		R-ML1208	R-ML1210	R-ML1212	R-ML1215	R-ML1220
13	15									R-ML1315	
14	16							R-ML1410	R-ML1412	R-ML1415	R-ML1420
15	17							R-ML1510	R-ML1512	R-ML1515	R-ML1520
16	18							R-ML1610	R-ML1612	R-ML1615	R-ML1620
17	19									R-ML1715	
18	20							R-ML1810	R-ML1812	R-ML1815	R-ML1820
19	22									R-ML1915	
20	23							R-ML2010	R-ML2012	R-ML2015	R-ML2020
22	25							R-ML2210	R-ML2212	R-ML2215	R-ML2220
24	27									R-ML2415	R-ML2420
25	28							R-ML2510	R-ML2512	R-ML2515	R-ML2520
26	30										R-ML2620
28	32								R-ML2812	R-ML2815	R-ML2820
30	34								R-ML3012	R-ML3015	R-ML3020
31	35										
32	36										R-ML3220
35	39								R-ML3512		R-ML3520
38	42										R-ML3820
40	44								R-ML4012		R-ML4020
45	50										R-ML4520
50	55							R-ML5010			R-ML5020
55	60										
60	65										
65	70										
70	75										

Remark 1. Use $1.2 \times 10^{-7} \text{ mm}^3/\text{N}\cdot\text{Em}$ as a guide line for the specific wear rate *K*.

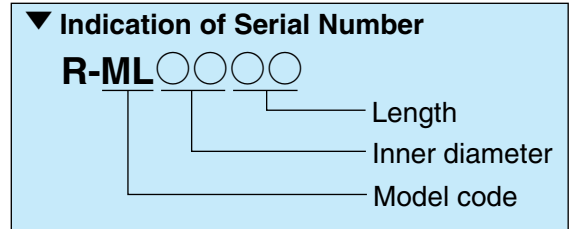

Dimensions to be measured at 25°C

Part No.						Dimension <i>C</i> mm	Recommended Fit mm		Mounted clearance mm (When mounted in H7 housing made of carbide)	
Length <i>l</i> (Tolerances $\begin{smallmatrix} 0 \\ -0.25 \end{smallmatrix}$) mm							Shaft h7	Housing H7	Minimum	Maximum
25	30	40	50	60	80					
						0.3	3 $\begin{smallmatrix} 0 \\ -0.010 \end{smallmatrix}$	5 $\begin{smallmatrix} +0.012 \\ 0 \end{smallmatrix}$	0.025	0.075
						0.5	4 $\begin{smallmatrix} 0 \\ -0.012 \end{smallmatrix}$	6 $\begin{smallmatrix} +0.012 \\ 0 \end{smallmatrix}$	0.025	0.085
						0.5	5 $\begin{smallmatrix} 0 \\ -0.012 \end{smallmatrix}$	7 $\begin{smallmatrix} +0.015 \\ 0 \end{smallmatrix}$	0.025	0.095
						0.5	6 $\begin{smallmatrix} 0 \\ -0.012 \end{smallmatrix}$	8 $\begin{smallmatrix} +0.015 \\ 0 \end{smallmatrix}$	0.025	0.095
						0.5	7 $\begin{smallmatrix} 0 \\ -0.015 \end{smallmatrix}$	9 $\begin{smallmatrix} +0.015 \\ 0 \end{smallmatrix}$	0.025	0.100
						0.5	8 $\begin{smallmatrix} 0 \\ -0.015 \end{smallmatrix}$	10 $\begin{smallmatrix} +0.015 \\ 0 \end{smallmatrix}$	0.025	0.100
						0.5	9 $\begin{smallmatrix} 0 \\ -0.015 \end{smallmatrix}$	11 $\begin{smallmatrix} +0.018 \\ 0 \end{smallmatrix}$	0.025	0.100
						0.5	10 $\begin{smallmatrix} 0 \\ -0.015 \end{smallmatrix}$	12 $\begin{smallmatrix} +0.018 \\ 0 \end{smallmatrix}$	0.025	0.100
						0.5	12 $\begin{smallmatrix} 0 \\ -0.018 \end{smallmatrix}$	14 $\begin{smallmatrix} +0.018 \\ 0 \end{smallmatrix}$	0.025	0.115
						0.5	13 $\begin{smallmatrix} 0 \\ -0.018 \end{smallmatrix}$	15 $\begin{smallmatrix} +0.018 \\ 0 \end{smallmatrix}$	0.025	0.115
						0.5	14 $\begin{smallmatrix} 0 \\ -0.018 \end{smallmatrix}$	16 $\begin{smallmatrix} +0.018 \\ 0 \end{smallmatrix}$	0.025	0.115
R-ML1525						0.5	15 $\begin{smallmatrix} 0 \\ -0.018 \end{smallmatrix}$	17 $\begin{smallmatrix} +0.018 \\ 0 \end{smallmatrix}$	0.025	0.115
R-ML1625						0.5	16 $\begin{smallmatrix} 0 \\ -0.018 \end{smallmatrix}$	18 $\begin{smallmatrix} +0.018 \\ 0 \end{smallmatrix}$	0.025	0.115
						0.5	17 $\begin{smallmatrix} 0 \\ -0.018 \end{smallmatrix}$	19 $\begin{smallmatrix} +0.021 \\ 0 \end{smallmatrix}$	0.025	0.115
R-ML1825						0.5	18 $\begin{smallmatrix} 0 \\ -0.018 \end{smallmatrix}$	20 $\begin{smallmatrix} +0.021 \\ 0 \end{smallmatrix}$	0.025	0.115
						0.7	19 $\begin{smallmatrix} 0 \\ -0.021 \end{smallmatrix}$	22 $\begin{smallmatrix} +0.021 \\ 0 \end{smallmatrix}$	0.025	0.130
R-ML2025	R-ML2030					0.7	20 $\begin{smallmatrix} 0 \\ -0.021 \end{smallmatrix}$	23 $\begin{smallmatrix} +0.021 \\ 0 \end{smallmatrix}$	0.025	0.130
R-ML2225						0.7	22 $\begin{smallmatrix} 0 \\ -0.021 \end{smallmatrix}$	25 $\begin{smallmatrix} +0.021 \\ 0 \end{smallmatrix}$	0.025	0.130
R-ML2425	R-ML2430					0.7	24 $\begin{smallmatrix} 0 \\ -0.021 \end{smallmatrix}$	27 $\begin{smallmatrix} +0.021 \\ 0 \end{smallmatrix}$	0.025	0.130
R-ML2525	R-ML2530					0.7	25 $\begin{smallmatrix} 0 \\ -0.021 \end{smallmatrix}$	28 $\begin{smallmatrix} +0.021 \\ 0 \end{smallmatrix}$	0.025	0.130
R-ML2625	R-ML2630					0.9	26 $\begin{smallmatrix} 0 \\ -0.021 \end{smallmatrix}$	30 $\begin{smallmatrix} +0.021 \\ 0 \end{smallmatrix}$	0.025	0.130
	R-ML2830					0.9	28 $\begin{smallmatrix} 0 \\ -0.021 \end{smallmatrix}$	32 $\begin{smallmatrix} +0.025 \\ 0 \end{smallmatrix}$	0.025	0.135
R-ML3025	R-ML3030	R-ML3040				0.9	30 $\begin{smallmatrix} 0 \\ -0.021 \end{smallmatrix}$	34 $\begin{smallmatrix} +0.025 \\ 0 \end{smallmatrix}$	0.025	0.135
R-ML3125		R-ML3140				0.9	31 $\begin{smallmatrix} 0 \\ -0.025 \end{smallmatrix}$	35 $\begin{smallmatrix} +0.025 \\ 0 \end{smallmatrix}$	0.035	0.165
R-ML3225	R-ML3230	R-ML3240				0.9	32 $\begin{smallmatrix} 0 \\ -0.025 \end{smallmatrix}$	36 $\begin{smallmatrix} +0.025 \\ 0 \end{smallmatrix}$	0.035	0.165
R-ML3525	R-ML3530	R-ML3540	R-ML3550			0.9	35 $\begin{smallmatrix} 0 \\ -0.025 \end{smallmatrix}$	39 $\begin{smallmatrix} +0.025 \\ 0 \end{smallmatrix}$	0.035	0.165
		R-ML3840				0.9	38 $\begin{smallmatrix} 0 \\ -0.025 \end{smallmatrix}$	42 $\begin{smallmatrix} +0.025 \\ 0 \end{smallmatrix}$	0.035	0.165
R-ML4025	R-ML4030	R-ML4040	R-ML4050			0.9	40 $\begin{smallmatrix} 0 \\ -0.025 \end{smallmatrix}$	44 $\begin{smallmatrix} +0.025 \\ 0 \end{smallmatrix}$	0.035	0.165
R-ML4525	R-ML4530	R-ML4540	R-ML4550			1.1	45 $\begin{smallmatrix} 0 \\ -0.025 \end{smallmatrix}$	50 $\begin{smallmatrix} +0.025 \\ 0 \end{smallmatrix}$	0.035	0.165
	R-ML5030	R-ML5040	R-ML5050	R-ML5060		1.1	50 $\begin{smallmatrix} 0 \\ -0.025 \end{smallmatrix}$	55 $\begin{smallmatrix} +0.030 \\ 0 \end{smallmatrix}$	0.035	0.165
	R-ML5530	R-ML5540		R-ML5560		1.1	55 $\begin{smallmatrix} 0 \\ -0.030 \end{smallmatrix}$	60 $\begin{smallmatrix} +0.030 \\ 0 \end{smallmatrix}$	0.045	0.195
	R-ML6030	R-ML6040		R-ML6060		1.1	60 $\begin{smallmatrix} 0 \\ -0.030 \end{smallmatrix}$	65 $\begin{smallmatrix} +0.030 \\ 0 \end{smallmatrix}$	0.045	0.195
	R-ML6530	R-ML6540		R-ML6560		1.1	65 $\begin{smallmatrix} 0 \\ -0.030 \end{smallmatrix}$	70 $\begin{smallmatrix} +0.030 \\ 0 \end{smallmatrix}$	0.045	0.195
		R-ML7040		R-ML7060	R-ML7080	1.1	70 $\begin{smallmatrix} 0 \\ -0.030 \end{smallmatrix}$	75 $\begin{smallmatrix} +0.030 \\ 0 \end{smallmatrix}$	0.045	0.195

MLC TYPE

MLC bearing

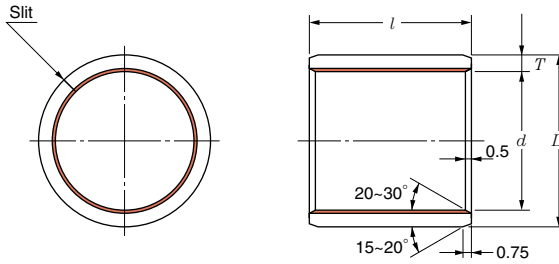

Note) The chamfering dimensions for a bush, 10mm or less in outside diameter or 7mm or less in length, should be limited to those needed for deburring, regardless of dimensioning in the drawing.

Inner diameter <i>d</i>	Outer diameter <i>D</i>	Length <i>l</i> (Tolerances $\frac{0}{-0.4}$)											
		3	4	5	6	7	8	10	12	15	20	25	30
3	5	MLC0303	MLC0304	MLC0305	MLC0306								
4	6	MLC0403	MLC0404		MLC0406		MLC0408						
5	7		MLC0504	MLC0505	MLC0506		MLC0508						
6	8			MLC0605	MLC0606	MLC0607	MLC0608	MLC0610					
7	9			MLC0705		MLC0707		MLC0710	MLC0712				
8	10			MLC0805	MLC0806	MLC0807	MLC0808	MLC0810	MLC0812				
9	11					MLC0907		MLC0910					
10	12				MLC1006	MLC1007	MLC1008	MLC1010	MLC1012	MLC1015	MLC1020		
12	14				MLC1206		MLC1208	MLC1210	MLC1212	MLC1215	MLC1220		
13	15						MLC1308	MLC1310		MLC1315			
14	16				MLC1406			MLC1410	MLC1412	MLC1415	MLC1420		
15	17						MLC1508	MLC1510	MLC1512	MLC1515	MLC1520	MLC1525	
16	18							MLC1610	MLC1612	MLC1615	MLC1620	MLC1625	
17	19									MLC1715	MLC1720		
18	20							MLC1810	MLC1812	MLC1815	MLC1820	MLC1825	
19	22							MLC1910		MLC1915			
20	23							MLC2010	MLC2012	MLC2015	MLC2020	MLC2025	MLC2030
22	25							MLC2210	MLC2212	MLC2215	MLC2220	MLC2225	MLC2230
24	27							MLC2410		MLC2415	MLC2420	MLC2425	MLC2430
25	28							MLC2510	MLC2512	MLC2515	MLC2520	MLC2525	MLC2530
26	30									MLC2615	MLC2620		MLC2630
28	32							MLC2810	MLC2812	MLC2815	MLC2820	MLC2825	MLC2830
30	34							MLC3010	MLC3012	MLC3015	MLC3020	MLC3025	MLC3030
31	35									MLC3115		MLC3125	
32	36										MLC3220	MLC3225	MLC3230
35	39							MLC3510	MLC3512	MLC3515	MLC3520	MLC3525	MLC3530
38	42										MLC3820	MLC3825	MLC3830
40	44								MLC4012	MLC4015	MLC4020	MLC4025	MLC4030
45	50								MLC4512		MLC4520	MLC4525	MLC4530
50	55								MLC5012	MLC5015	MLC5020	MLC5025	MLC5030
55	60								MLC5512			MLC5525	MLC5530
60	65									MLC6015	MLC6020		MLC6030
65	70									MLC6515			MLC6530
70	75									MLC7015	MLC7020		MLC7030
75	80										MLC7520		MLC7530
80	85									MLC8015	MLC8020		MLC8030
85	90												MLC8530
90	95										MLC9020		
95	100												MLC9530
100	105												MLC10030
105	110												
110	115										MLC11020		MLC11030
120	125												
130	135										MLC13020		
140	145												
150	155												
160	165												

Remarks 1. The minimum clearance is 0.025 mm when the preferred shaft and housing are used.
 2. Use $1.7 \times 10^{-7} \text{ mm}^3/\text{N}\cdot\text{Em}$ as a guide line for the specific wear rate *K*.

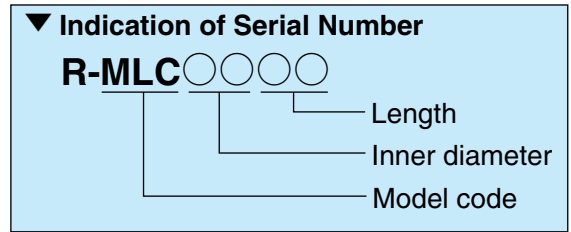

Dimensions to be measured at 25°C / unit in mm

Length / (Tolerances $\begin{smallmatrix} 0 \\ -0.4 \end{smallmatrix}$)									Wall thickness	Recommended shaft	Recommended housing	
35	40	50	60	70	80	90	95	100	T	d_a	D_a	
									1.0 $\begin{smallmatrix} 0 \\ -0.025 \end{smallmatrix}$	3 $\begin{smallmatrix} -0.025 \\ -0.035 \end{smallmatrix}$	5 (H7) $\begin{smallmatrix} +0.012 \\ 0 \end{smallmatrix}$	
										4 $\begin{smallmatrix} -0.025 \\ -0.037 \end{smallmatrix}$	6 (H7) $\begin{smallmatrix} +0.012 \\ 0 \end{smallmatrix}$	
										5 $\begin{smallmatrix} -0.025 \\ -0.037 \end{smallmatrix}$	7 (H7) $\begin{smallmatrix} +0.015 \\ 0 \end{smallmatrix}$	
										6 $\begin{smallmatrix} -0.025 \\ -0.037 \end{smallmatrix}$	8 (H7) $\begin{smallmatrix} +0.015 \\ 0 \end{smallmatrix}$	
										7 $\begin{smallmatrix} -0.025 \\ -0.040 \end{smallmatrix}$	9 (H7) $\begin{smallmatrix} +0.015 \\ 0 \end{smallmatrix}$	
										8 $\begin{smallmatrix} -0.025 \\ -0.040 \end{smallmatrix}$	10 (H7) $\begin{smallmatrix} +0.015 \\ 0 \end{smallmatrix}$	
										9 $\begin{smallmatrix} -0.025 \\ -0.040 \end{smallmatrix}$	11 (H7) $\begin{smallmatrix} +0.018 \\ 0 \end{smallmatrix}$	
										10 $\begin{smallmatrix} -0.025 \\ -0.040 \end{smallmatrix}$	12 (H7) $\begin{smallmatrix} +0.018 \\ 0 \end{smallmatrix}$	
										12 $\begin{smallmatrix} -0.025 \\ -0.043 \end{smallmatrix}$	14 (H7) $\begin{smallmatrix} +0.018 \\ 0 \end{smallmatrix}$	
										13 $\begin{smallmatrix} -0.025 \\ -0.043 \end{smallmatrix}$	15 (H7) $\begin{smallmatrix} +0.018 \\ 0 \end{smallmatrix}$	
										14 $\begin{smallmatrix} -0.025 \\ -0.043 \end{smallmatrix}$	16 (H7) $\begin{smallmatrix} +0.018 \\ 0 \end{smallmatrix}$	
										15 $\begin{smallmatrix} -0.025 \\ -0.043 \end{smallmatrix}$	17 (H7) $\begin{smallmatrix} +0.018 \\ 0 \end{smallmatrix}$	
										16 $\begin{smallmatrix} -0.025 \\ -0.043 \end{smallmatrix}$	18 (H7) $\begin{smallmatrix} +0.018 \\ 0 \end{smallmatrix}$	
										17 $\begin{smallmatrix} -0.025 \\ -0.043 \end{smallmatrix}$	19 (H7) $\begin{smallmatrix} +0.021 \\ 0 \end{smallmatrix}$	
										18 $\begin{smallmatrix} -0.025 \\ -0.043 \end{smallmatrix}$	20 (H7) $\begin{smallmatrix} +0.021 \\ 0 \end{smallmatrix}$	
										1.5 $\begin{smallmatrix} 0 \\ -0.030 \end{smallmatrix}$	19 $\begin{smallmatrix} -0.025 \\ -0.046 \end{smallmatrix}$	22 (H7) $\begin{smallmatrix} +0.021 \\ 0 \end{smallmatrix}$
											20 $\begin{smallmatrix} -0.025 \\ -0.046 \end{smallmatrix}$	23 (H7) $\begin{smallmatrix} +0.021 \\ 0 \end{smallmatrix}$
											22 $\begin{smallmatrix} -0.025 \\ -0.046 \end{smallmatrix}$	25 (H7) $\begin{smallmatrix} +0.021 \\ 0 \end{smallmatrix}$
									24 $\begin{smallmatrix} -0.025 \\ -0.046 \end{smallmatrix}$		27 (H7) $\begin{smallmatrix} +0.021 \\ 0 \end{smallmatrix}$	
MLC2535	MLC2540								2.0 $\begin{smallmatrix} 0 \\ -0.030 \end{smallmatrix}$	25 $\begin{smallmatrix} -0.025 \\ -0.046 \end{smallmatrix}$	28 (H7) $\begin{smallmatrix} +0.021 \\ 0 \end{smallmatrix}$	
										26 $\begin{smallmatrix} -0.025 \\ -0.046 \end{smallmatrix}$	30 (H7) $\begin{smallmatrix} +0.021 \\ 0 \end{smallmatrix}$	
										28 $\begin{smallmatrix} -0.025 \\ -0.046 \end{smallmatrix}$	32 (H7) $\begin{smallmatrix} +0.025 \\ 0 \end{smallmatrix}$	
MLC3035	MLC3040									30 $\begin{smallmatrix} -0.025 \\ -0.046 \end{smallmatrix}$	34 (H7) $\begin{smallmatrix} +0.025 \\ 0 \end{smallmatrix}$	
	MLC3140								2.5 $\begin{smallmatrix} 0 \\ -0.040 \end{smallmatrix}$	31 $\begin{smallmatrix} -0.025 \\ -0.050 \end{smallmatrix}$	35 (H7) $\begin{smallmatrix} +0.025 \\ 0 \end{smallmatrix}$	
MLC3235	MLC3240	MLC3250								32 $\begin{smallmatrix} -0.025 \\ -0.050 \end{smallmatrix}$	36 (H7) $\begin{smallmatrix} +0.025 \\ 0 \end{smallmatrix}$	
MLC3535	MLC3540	MLC3550								35 $\begin{smallmatrix} -0.025 \\ -0.050 \end{smallmatrix}$	39 (H7) $\begin{smallmatrix} +0.025 \\ 0 \end{smallmatrix}$	
MLC3835	MLC3840									38 $\begin{smallmatrix} -0.025 \\ -0.050 \end{smallmatrix}$	42 (H7) $\begin{smallmatrix} +0.025 \\ 0 \end{smallmatrix}$	
MLC4035	MLC4040	MLC4050								40 $\begin{smallmatrix} -0.025 \\ -0.050 \end{smallmatrix}$	44 (H7) $\begin{smallmatrix} +0.025 \\ 0 \end{smallmatrix}$	
MLC4535	MLC4540	MLC4550								45 $\begin{smallmatrix} -0.025 \\ -0.050 \end{smallmatrix}$	50 (H7) $\begin{smallmatrix} +0.025 \\ 0 \end{smallmatrix}$	
MLC5035	MLC5040	MLC5050	MLC5060		MLC5080					50 $\begin{smallmatrix} -0.025 \\ -0.050 \end{smallmatrix}$	55 (H7) $\begin{smallmatrix} +0.030 \\ 0 \end{smallmatrix}$	
MLC5535	MLC5540	MLC5550	MLC5560							55 $\begin{smallmatrix} -0.025 \\ -0.055 \end{smallmatrix}$	60 (H7) $\begin{smallmatrix} +0.030 \\ 0 \end{smallmatrix}$	
MLC6035	MLC6040	MLC6050	MLC6060	MLC6070					60 $\begin{smallmatrix} -0.025 \\ -0.055 \end{smallmatrix}$	65 (H7) $\begin{smallmatrix} +0.030 \\ 0 \end{smallmatrix}$		
	MLC6540	MLC6550	MLC6560	MLC6570					65 $\begin{smallmatrix} +0.035 \\ +0.005 \end{smallmatrix}$	70 (H7) $\begin{smallmatrix} +0.030 \\ 0 \end{smallmatrix}$		
MLC7035	MLC7040	MLC7050	MLC7060		MLC7080				70 $\begin{smallmatrix} +0.035 \\ +0.005 \end{smallmatrix}$	75 (H7) $\begin{smallmatrix} +0.030 \\ 0 \end{smallmatrix}$		
MLC7535	MLC7540	MLC7550	MLC7560		MLC7580				75 $\begin{smallmatrix} +0.035 \\ +0.005 \end{smallmatrix}$	80 (H7) $\begin{smallmatrix} +0.030 \\ 0 \end{smallmatrix}$		
	MLC8040	MLC8050	MLC8060		MLC8080				80 $\begin{smallmatrix} +0.035 \\ +0.005 \end{smallmatrix}$	85 (H7) $\begin{smallmatrix} +0.035 \\ 0 \end{smallmatrix}$		
	MLC8540	MLC8550	MLC8560		MLC8580				85 $\begin{smallmatrix} +0.035 \\ 0 \end{smallmatrix}$	90 (H7) $\begin{smallmatrix} +0.035 \\ 0 \end{smallmatrix}$		
MLC9035	MLC9040	MLC9050	MLC9060			MLC9090			90 $\begin{smallmatrix} +0.035 \\ 0 \end{smallmatrix}$	95 (H7) $\begin{smallmatrix} +0.035 \\ 0 \end{smallmatrix}$		
MLC9535	MLC9540								95 $\begin{smallmatrix} +0.035 \\ 0 \end{smallmatrix}$	100 (H7) $\begin{smallmatrix} +0.035 \\ 0 \end{smallmatrix}$		
MLC10035	MLC10040	MLC10050		MLC10070				MLC10095	2.47 $\begin{smallmatrix} 0 \\ -0.050 \end{smallmatrix}$	100 $\begin{smallmatrix} +0.035 \\ 0 \end{smallmatrix}$	105 (H7) $\begin{smallmatrix} +0.035 \\ 0 \end{smallmatrix}$	
		MLC10550					MLC10590	MLC10595		105 $\begin{smallmatrix} +0.035 \\ 0 \end{smallmatrix}$	110 (H7) $\begin{smallmatrix} +0.035 \\ 0 \end{smallmatrix}$	
MLC11035	MLC11040	MLC11050	MLC11060	MLC11070	MLC11080	MLC11090	MLC11095			110 $\begin{smallmatrix} +0.035 \\ 0 \end{smallmatrix}$	115 (H7) $\begin{smallmatrix} +0.035 \\ 0 \end{smallmatrix}$	
	MLC12040	MLC12050	MLC12060	MLC12070				MLC12095		120 $\begin{smallmatrix} +0.035 \\ 0 \end{smallmatrix}$	125 (H7) $\begin{smallmatrix} +0.040 \\ 0 \end{smallmatrix}$	
		MLC13050			MLC13080					130 $\begin{smallmatrix} +0.035 \\ -0.005 \end{smallmatrix}$	135 (H7) $\begin{smallmatrix} +0.040 \\ 0 \end{smallmatrix}$	
		MLC14050		MLC14070	MLC14080			MLC140100		140 $\begin{smallmatrix} +0.035 \\ -0.005 \end{smallmatrix}$	145 (H7) $\begin{smallmatrix} +0.040 \\ 0 \end{smallmatrix}$	
	MLC15040	MLC15050			MLC15080			MLC150100		150 $\begin{smallmatrix} +0.035 \\ -0.005 \end{smallmatrix}$	155 (H7) $\begin{smallmatrix} +0.040 \\ 0 \end{smallmatrix}$	
		MLC16050			MLC16080			MLC160100		160 $\begin{smallmatrix} +0.035 \\ -0.005 \end{smallmatrix}$	165 (H7) $\begin{smallmatrix} +0.040 \\ 0 \end{smallmatrix}$	

MLCF TYPE

MLC bearing

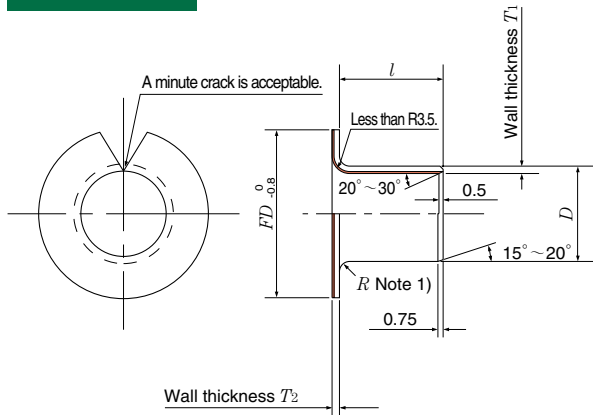

Note 1) The dimension R shown in the above drawing is less than 0.75 when the wall thickness $T_1 = 1.0$, but less than 1.0 when the wall thickness T_2 is larger than 1.5.

Indication of Serial Number

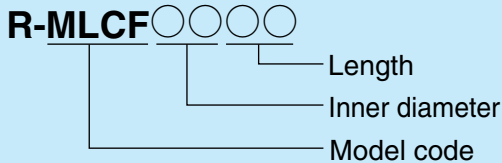

Inner diameter d	Outer diameter D	Collar diameter FD	Length l (Tolerances $\begin{smallmatrix} 0 \\ -0.4 \end{smallmatrix}$)					
			3	4	5	6	7	8
3	4.6	7	MLCF0303					
4	5.6	9		MLCF0404				
5	7	10		MLCF0504	MLCF0505			
6	8	12			MLCF0605	MLCF0606	MLCF0607	MLCF0608
7	9	13			MLCF0705		MLCF0707	
8	10	15				MLCF0806		MLCF0808
10	12	18				MLCF1006	MLCF1007	MLCF1008
12	14	20				MLCF1206		MLCF1208
14	16	22						
15	17	23						
16	18	24						
18	20	26						
20	23	31						
22	25	33						
24	27	35						
25	28	36						
26	30	38						
28	32	40						
30	34	42						
31	35	45						
32	36	46						
35	39	49						
38	42	52						
40	44	54						
45	50	60						
50	55	65						
55	60	70						
60	65	75						

Remarks 1. The minimum clearance is 0.025 mm when the preferred shaft and housing are used.

2. Use $1.7 \times 10^{-7} \text{ mm}^3/\text{N}\cdot\text{Em}$ as a guide line for the specific wear rate K .

MLCW TYPE

MLC bearing

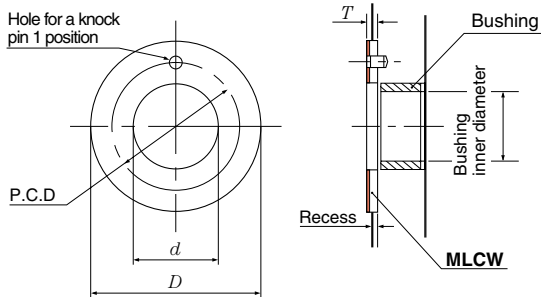

Indication of Serial Number

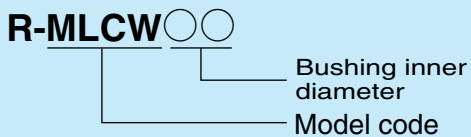

Bushing inner diameter for combination	Part No.	Inner diameter d mm	Outer diameter D mm	Wall thickness T mm
6	MLCW06	8 $\begin{smallmatrix} +0.25 \\ 0 \end{smallmatrix}$	16 $\begin{smallmatrix} 0 \\ -0.25 \end{smallmatrix}$	1.5 $\begin{smallmatrix} -0.03 \\ -0.08 \end{smallmatrix}$
8	MLCW08	10 $\begin{smallmatrix} +0.25 \\ 0 \end{smallmatrix}$	18 $\begin{smallmatrix} 0 \\ -0.25 \end{smallmatrix}$	1.5 $\begin{smallmatrix} -0.03 \\ -0.08 \end{smallmatrix}$
10	MLCW10	12 $\begin{smallmatrix} +0.25 \\ 0 \end{smallmatrix}$	24 $\begin{smallmatrix} 0 \\ -0.25 \end{smallmatrix}$	1.5 $\begin{smallmatrix} -0.03 \\ -0.08 \end{smallmatrix}$
12	MLCW12	14 $\begin{smallmatrix} +0.25 \\ 0 \end{smallmatrix}$	26 $\begin{smallmatrix} 0 \\ -0.25 \end{smallmatrix}$	1.5 $\begin{smallmatrix} -0.03 \\ -0.08 \end{smallmatrix}$
14	MLCW14	16 $\begin{smallmatrix} +0.25 \\ 0 \end{smallmatrix}$	30 $\begin{smallmatrix} 0 \\ -0.25 \end{smallmatrix}$	1.5 $\begin{smallmatrix} -0.03 \\ -0.08 \end{smallmatrix}$
16	MLCW16	18 $\begin{smallmatrix} +0.25 \\ 0 \end{smallmatrix}$	32 $\begin{smallmatrix} 0 \\ -0.25 \end{smallmatrix}$	1.5 $\begin{smallmatrix} -0.03 \\ -0.08 \end{smallmatrix}$
18	MLCW18	20 $\begin{smallmatrix} +0.25 \\ 0 \end{smallmatrix}$	36 $\begin{smallmatrix} 0 \\ -0.25 \end{smallmatrix}$	1.5 $\begin{smallmatrix} -0.03 \\ -0.08 \end{smallmatrix}$
20	MLCW20	22 $\begin{smallmatrix} +0.25 \\ 0 \end{smallmatrix}$	38 $\begin{smallmatrix} 0 \\ -0.25 \end{smallmatrix}$	1.5 $\begin{smallmatrix} -0.03 \\ -0.08 \end{smallmatrix}$
22	MLCW22	24 $\begin{smallmatrix} +0.25 \\ 0 \end{smallmatrix}$	42 $\begin{smallmatrix} 0 \\ -0.25 \end{smallmatrix}$	1.5 $\begin{smallmatrix} -0.03 \\ -0.08 \end{smallmatrix}$
24	MLCW24	26 $\begin{smallmatrix} +0.25 \\ 0 \end{smallmatrix}$	44 $\begin{smallmatrix} 0 \\ -0.25 \end{smallmatrix}$	1.5 $\begin{smallmatrix} -0.03 \\ -0.08 \end{smallmatrix}$
25	MLCW25	28 $\begin{smallmatrix} +0.25 \\ 0 \end{smallmatrix}$	48 $\begin{smallmatrix} 0 \\ -0.25 \end{smallmatrix}$	1.5 $\begin{smallmatrix} -0.03 \\ -0.08 \end{smallmatrix}$
30	MLCW30	32 $\begin{smallmatrix} +0.25 \\ 0 \end{smallmatrix}$	54 $\begin{smallmatrix} 0 \\ -0.25 \end{smallmatrix}$	1.5 $\begin{smallmatrix} -0.03 \\ -0.08 \end{smallmatrix}$
35	MLCW35	38 $\begin{smallmatrix} +0.25 \\ 0 \end{smallmatrix}$	62 $\begin{smallmatrix} 0 \\ -0.25 \end{smallmatrix}$	1.5 $\begin{smallmatrix} -0.03 \\ -0.08 \end{smallmatrix}$
40	MLCW40	42 $\begin{smallmatrix} +0.25 \\ 0 \end{smallmatrix}$	66 $\begin{smallmatrix} 0 \\ -0.25 \end{smallmatrix}$	1.5 $\begin{smallmatrix} -0.03 \\ -0.08 \end{smallmatrix}$
45	MLCW45	48 $\begin{smallmatrix} +0.25 \\ 0 \end{smallmatrix}$	74 $\begin{smallmatrix} 0 \\ -0.25 \end{smallmatrix}$	2.0 $\begin{smallmatrix} -0.03 \\ -0.08 \end{smallmatrix}$
50	MLCW50	52 $\begin{smallmatrix} +0.25 \\ 0 \end{smallmatrix}$	78 $\begin{smallmatrix} 0 \\ -0.25 \end{smallmatrix}$	2.0 $\begin{smallmatrix} -0.03 \\ -0.08 \end{smallmatrix}$

Remark 1. The minimum clearance is 0.025 mm when the preferred shaft and housing are used.

Dimensions to be measured at 25°C / unit in mm

Length <i>l</i> (Tolerances $\begin{smallmatrix} 0 \\ -0.4 \end{smallmatrix}$)										Wall thickness		Recommended shaft <i>d_a</i>	Recommended housing <i>D_a</i>		
10	12	15	20	25	30	40	45	50	60	<i>T</i> ₁	<i>T</i> ₂				
										0.8 $\begin{smallmatrix} 0 \\ -0.025 \end{smallmatrix}$	0.8 $\begin{smallmatrix} 0 \\ -0.2 \end{smallmatrix}$	3 $\begin{smallmatrix} -0.025 \\ -0.035 \end{smallmatrix}$	4.6 (H7) $\begin{smallmatrix} +0.012 \\ 0 \end{smallmatrix}$		
												4 $\begin{smallmatrix} -0.025 \\ -0.037 \end{smallmatrix}$	5.6 (H7) $\begin{smallmatrix} +0.012 \\ 0 \end{smallmatrix}$		
												5 $\begin{smallmatrix} -0.025 \\ -0.037 \end{smallmatrix}$	7 (H7) $\begin{smallmatrix} +0.015 \\ 0 \end{smallmatrix}$		
MLCF0610												6 $\begin{smallmatrix} -0.025 \\ -0.037 \end{smallmatrix}$	8 (H7) $\begin{smallmatrix} +0.015 \\ 0 \end{smallmatrix}$		
MLCF0710	MLCF0712									1.0 $\begin{smallmatrix} 0 \\ -0.025 \end{smallmatrix}$	1.0 $\begin{smallmatrix} 0 \\ -0.2 \end{smallmatrix}$	7 $\begin{smallmatrix} -0.025 \\ -0.040 \end{smallmatrix}$	9 (H7) $\begin{smallmatrix} +0.015 \\ 0 \end{smallmatrix}$		
MLCF0810	MLCF0812											8 $\begin{smallmatrix} -0.025 \\ -0.040 \end{smallmatrix}$	10 (H7) $\begin{smallmatrix} +0.015 \\ 0 \end{smallmatrix}$		
MLCF1010	MLCF1012	MLCF1015										10 $\begin{smallmatrix} -0.025 \\ -0.040 \end{smallmatrix}$	12 (H7) $\begin{smallmatrix} +0.018 \\ 0 \end{smallmatrix}$		
MLCF1210	MLCF1212	MLCF1215	MLCF1220									12 $\begin{smallmatrix} -0.025 \\ -0.043 \end{smallmatrix}$	14 (H7) $\begin{smallmatrix} +0.018 \\ 0 \end{smallmatrix}$		
MLCF1410	MLCF1412	MLCF1415	MLCF1420									14 $\begin{smallmatrix} -0.025 \\ -0.043 \end{smallmatrix}$	16 (H7) $\begin{smallmatrix} +0.018 \\ 0 \end{smallmatrix}$		
MLCF1510	MLCF1512	MLCF1515	MLCF1520	MLCF1525								15 $\begin{smallmatrix} -0.025 \\ -0.043 \end{smallmatrix}$	17 (H7) $\begin{smallmatrix} +0.018 \\ 0 \end{smallmatrix}$		
MLCF1610	MLCF1612	MLCF1615	MLCF1620	MLCF1625								16 $\begin{smallmatrix} -0.025 \\ -0.043 \end{smallmatrix}$	18 (H7) $\begin{smallmatrix} +0.018 \\ 0 \end{smallmatrix}$		
MLCF1810	MLCF1812	MLCF1815	MLCF1820	MLCF1825								18 $\begin{smallmatrix} -0.025 \\ -0.043 \end{smallmatrix}$	20 (H7) $\begin{smallmatrix} +0.021 \\ 0 \end{smallmatrix}$		
MLCF2010	MLCF2012	MLCF2015	MLCF2020	MLCF2025	MLCF2030							1.5 $\begin{smallmatrix} 0 \\ -0.030 \end{smallmatrix}$	1.5 $\begin{smallmatrix} 0 \\ -0.2 \end{smallmatrix}$	20 $\begin{smallmatrix} -0.025 \\ -0.046 \end{smallmatrix}$	23 (H7) $\begin{smallmatrix} +0.021 \\ 0 \end{smallmatrix}$
MLCF2210	MLCF2212	MLCF2215	MLCF2220	MLCF2225										22 $\begin{smallmatrix} -0.025 \\ -0.046 \end{smallmatrix}$	25 (H7) $\begin{smallmatrix} +0.021 \\ 0 \end{smallmatrix}$
		MLCF2415	MLCF2420	MLCF2425	MLCF2430									24 $\begin{smallmatrix} -0.025 \\ -0.046 \end{smallmatrix}$	27 (H7) $\begin{smallmatrix} +0.021 \\ 0 \end{smallmatrix}$
MLCF2510	MLCF2512	MLCF2515	MLCF2520	MLCF2525	MLCF2530									25 $\begin{smallmatrix} -0.025 \\ -0.046 \end{smallmatrix}$	28 (H7) $\begin{smallmatrix} +0.021 \\ 0 \end{smallmatrix}$
		MLCF2615	MLCF2620											26 $\begin{smallmatrix} -0.025 \\ -0.046 \end{smallmatrix}$	30 (H7) $\begin{smallmatrix} +0.021 \\ 0 \end{smallmatrix}$
	MLCF2812	MLCF2815	MLCF2820	MLCF2825	MLCF2830									28 $\begin{smallmatrix} -0.025 \\ -0.046 \end{smallmatrix}$	32 (H7) $\begin{smallmatrix} +0.025 \\ 0 \end{smallmatrix}$
	MLCF3012	MLCF3015	MLCF3020	MLCF3025	MLCF3030	MLCF3040								30 $\begin{smallmatrix} -0.025 \\ -0.046 \end{smallmatrix}$	34 (H7) $\begin{smallmatrix} +0.025 \\ 0 \end{smallmatrix}$
			MLCF3125											31 $\begin{smallmatrix} -0.025 \\ -0.050 \end{smallmatrix}$	35 (H7) $\begin{smallmatrix} +0.025 \\ 0 \end{smallmatrix}$
			MLCF3220	MLCF3225	MLCF3230									32 $\begin{smallmatrix} -0.025 \\ -0.050 \end{smallmatrix}$	36 (H7) $\begin{smallmatrix} +0.025 \\ 0 \end{smallmatrix}$
	MLCF3512		MLCF3520	MLCF3525	MLCF3530	MLCF3540	MLCF3545	MLCF3550						35 $\begin{smallmatrix} -0.025 \\ -0.050 \end{smallmatrix}$	39 (H7) $\begin{smallmatrix} +0.025 \\ 0 \end{smallmatrix}$
			MLCF3820	MLCF3825	MLCF3830	MLCF3840				38 $\begin{smallmatrix} -0.025 \\ -0.050 \end{smallmatrix}$	42 (H7) $\begin{smallmatrix} +0.025 \\ 0 \end{smallmatrix}$				
	MLCF4012		MLCF4020	MLCF4025	MLCF4030	MLCF4040		MLCF4050		40 $\begin{smallmatrix} -0.025 \\ -0.050 \end{smallmatrix}$	44 (H7) $\begin{smallmatrix} +0.025 \\ 0 \end{smallmatrix}$				
			MLCF4520	MLCF4525	MLCF4530	MLCF4540		MLCF4550		45 $\begin{smallmatrix} -0.025 \\ -0.050 \end{smallmatrix}$	50 (H7) $\begin{smallmatrix} +0.025 \\ 0 \end{smallmatrix}$				
			MLCF5020	MLCF5025	MLCF5030	MLCF5040		MLCF5050	MLCF5060	50 $\begin{smallmatrix} -0.025 \\ -0.050 \end{smallmatrix}$	55 (H7) $\begin{smallmatrix} +0.030 \\ 0 \end{smallmatrix}$				
					MLCF5530	MLCF5540		MLCF5550	MLCF5560	55 $\begin{smallmatrix} -0.025 \\ -0.055 \end{smallmatrix}$	60 (H7) $\begin{smallmatrix} +0.030 \\ 0 \end{smallmatrix}$				
					MLCF6030	MLCF6040		MLCF6050	MLCF6060	60 $\begin{smallmatrix} -0.025 \\ -0.055 \end{smallmatrix}$	65 (H7) $\begin{smallmatrix} +0.030 \\ 0 \end{smallmatrix}$				

Dimensions to be measured at 25°C

Knock pin hole diameter mm	Position of a knock pin P.C.D mm	Depth of the housing recess mm
1.100~1.300	12 ±0.12	0.95~1.20
1.100~1.300	14 ±0.12	0.95~1.20
1.625~1.875	18 ±0.12	0.95~1.20
2.125~2.375	20 ±0.12	0.95~1.20
2.125~2.375	23 ±0.12	0.95~1.20
2.125~2.375	25 ±0.12	0.95~1.20
3.125~3.375	28 ±0.12	0.95~1.20
3.125~3.375	30 ±0.12	0.95~1.20
3.125~3.375	33 ±0.12	0.95~1.20
3.125~3.375	35 ±0.12	0.95~1.20
4.125~4.375	38 ±0.12	0.95~1.20
4.125~4.375	43 ±0.12	0.95~1.20
4.125~4.375	50 ±0.12	0.95~1.20
4.125~4.375	54 ±0.12	0.95~1.20
4.125~4.375	61 ±0.12	1.45~1.70
4.125~4.375	65 ±0.12	1.45~1.70

3

NTN Engineering Plastics Material Standard Dimensions

NTN Engineering Plastics are widely used in many areas such as the machinery, electric, chemical industries. Among the materials of NTN Engineering Plastics, the most popular series of fluoroplastics based (**BEAREE FL 3000, FL 3020, FL 3030, FL 3700, FL 3305**) and ultra-high-molecular-weight polyethylene (**BEAREE UH 3954, UH 3000**) are prepared in sheets, rods or pipes for your own fabrication.

Sheet material

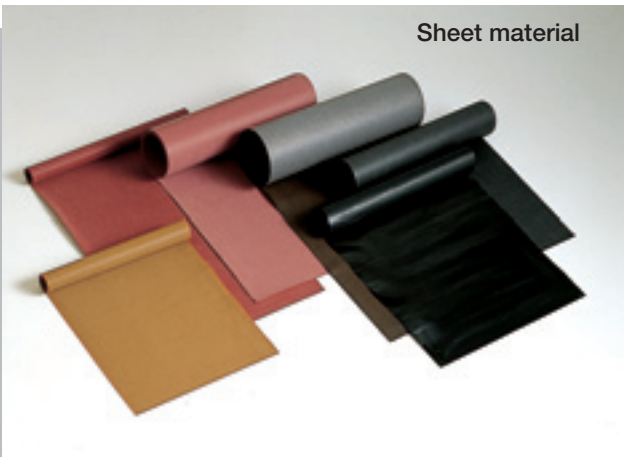

Rod material



Pipe material



Sheet material

Sheet material is skived (turned) from a large billet made by compression molding. Surface treatment (etching) is required to make the sheet bondable. In the case of using the sheet by bonding with adhesives, the material should be treated through the preparation process for bonding (TOS).

BEAREE UH 3954 cannot be etched. One side of BEAREE FL 3305 sheet is pre-etched for bonding unless otherwise requested.

Sheet material dimension table

(Unit in mm)

Dimension			Material							
Thickness (T)	Width (W)	Maximum continuous length* (L) m	BEAREE FL3000	BEAREE FL3020	BEAREE FL3030	BEAREE FL3700	BEAREE FL3305	BEAREE UH3954		
0.1±0.02	300 ⁺³⁰ ₀	10						○		
0.2±0.02								○		
0.3±0.03			○	○	○	○	○	○		
0.4±0.04			○	○	○	○	○	○		
0.5±0.05			○	○	○	○	○	○		
0.6±0.06			○	○	○	○	○			
0.8±0.06			○	○	○	○	○	○		
1 ±0.1			○	○	○	○	○	○		
1.2±0.1			500 ⁺³⁰ ₀ for BEAREE FL3020	5	○	○	○	○	○	
1.5±0.1					○	○	○	○	○	
2 ±0.2	○	○			○	○	○			
2.5±0.2	○	○			○	○	○			
3 ±0.3	1	1	○	○	○	○	○			
4 ±0.3			○	○	○	○	○			
5 ±0.4			○	○	○	○	○			
6 ±0.5			○	○	○	○	○			

Marked (○) is available; however, these materials are made to order. Please contact NTN if these materials are drawn as there is a possibility of cracking with certain drawing ratios.

* Length code for 1 m is M1.

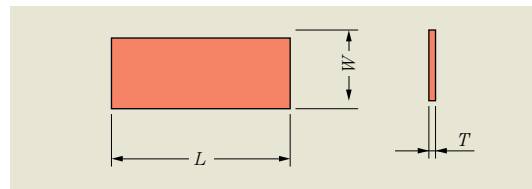
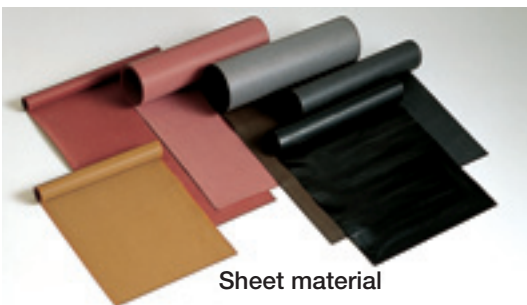

<Applications>

- Slider tape
- Washer
- Packing
- Other machine parts

Use the following designation of part number when making an order.

R-T□×□×M1□T0

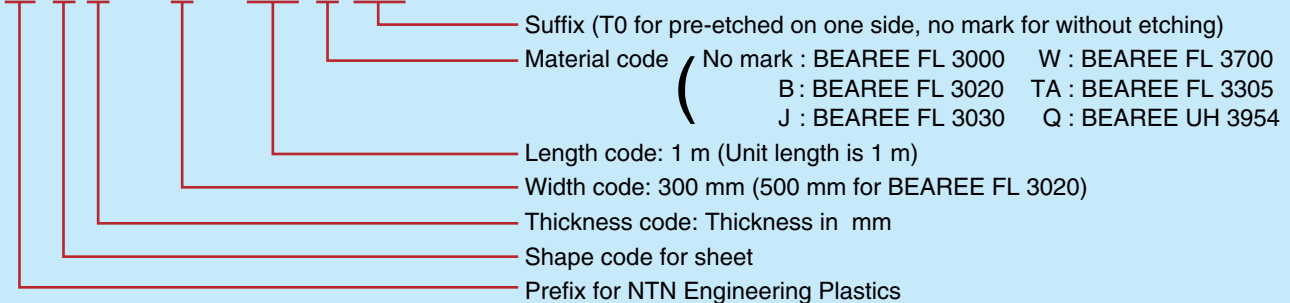

(Example) R-T0.3 × 300 × M1T0
BEAREE FL 3000 sheet with 0.3mm in thickness, 300mm in width, 1m in length and pre-etched on one side.

NOTE : For more than 1m in length, designate "CONTINUOUS SHEET"

Rod material

This material is formed by ram extrusion as a round bar.
 This material is made by ram extrusion to size. This material can be machined to the required profile by turning or milling.

Rod material dimension table (Unit in mm)

Dimension		Material			
O.D. (ϕD)	Length (L)	BEAREE FL3000	BEAREE FL3030	BEAREE FL3700	BEAREE UH3000
9	1,000*	○	○	○	
12		○			
13					
15		○			
17		○	○		○
19		○			
20					
21					
22		○			
23		○			
28		○			
30					○
33		○			
37		○			

Marked (○) is available; however these materials are made by order.
 The machining allowance should be deducted from the above shown dimensions.
 Material dimensions exclude the turning surplus.

* Length code for 1000 mm is M1.

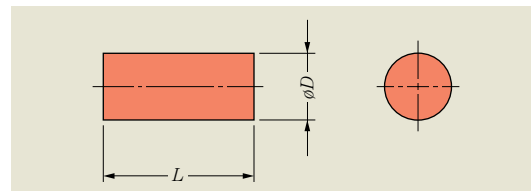

<Applications>

- Bearing bushing
- Washer
- Packing
- Other machine parts

Use the following designation of part number when making an order.

R-R□×M1□

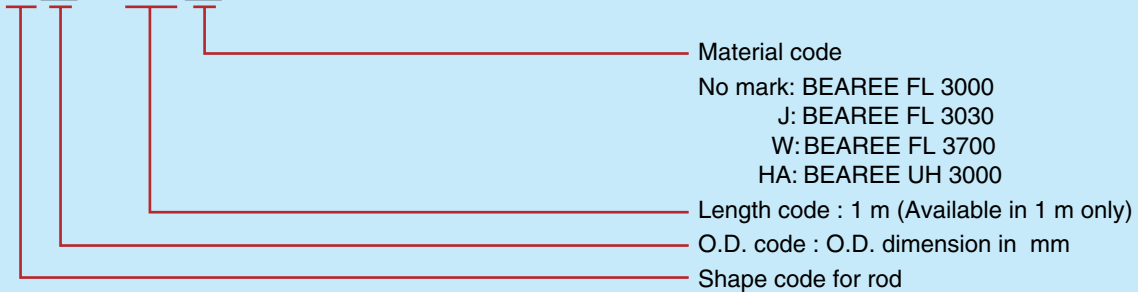

(Example) R-R13×M1W
 BEAREE FL 3700 rod material, 13mm in O.D. and 1m in length.

Pipe material

This pipe material is made by ram extrusion to a cylinder. This material can be machined to the required profile by turning or milling.

Dimension table for pipe material (Unit in mm)

Dimension			Material			
I.D. (ϕd)	O.D. (ϕD)	Length(L)	BEAREE FL 3000	BEAREE FL 3030	BEAREE FL 3700	BEAREE UH 3000
7	22	1,000*		○		
9	19		○		○	
10	25					○
11	20		○			
13	21					○
13	23				○	○
13	28		○			
15	20					○
15	26		○			
15	28					○
15	30		○			
17	26					○
17	27				○	
18	33		○			○
19	34					○
21	31				○	
21	38		○			○
21	42					○
21	45					○
27	43		○			
27	45				○	
29	36			○		
35	43			○		
38	46			○		

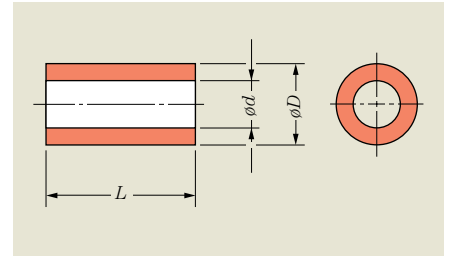

Pipe material

<Applications>

- Sliding bearing
- Washer
- Valve seat
- Other machine parts

Marked ○ is available however these materials are made by order.
The machining allowance should be deducted from the above shown dimensions.
Material dimensions exclude the turning surplus.

* Length code for 1000 mm is M1.

Use the following designation of part number when making an order.

R-U□×□×M1□

- Material code: The same as rod material
- Length code: 1 m (Available in 1 m only)
- O.D. code: O.D. dimension in mm
- I.D. code: I.D. dimension in mm
- Shape code for pipe

(Example) R-U13×23×M1J

BEAREE FL 3030 pipe material, 13mm in I.D., 23mm O.D. and 1m in length.



Introduction of Materials and Products for Applications

4-1

This high performance sliding bearing uses base materials such as polyimide (PI), polyamideimide (PAI), polyphenylsulfide (PPS), polyacetal (POM), polyamide (PA), polyethylene (PE) featuring the fluoro plastics (PTFE) as a main material.

Bearings, piston rings and seal rings with unique characteristics of each base plastics can be manufactured according to orders.

Table 1 Allowable pressure, feature and applications

Grade	Properties Base Resin	Allowable pressure		Characteristics	Applications
		MPa	kgf/cm ²		
BEAREE FL 3000	PTFE	7	70	Fluoro plastics standard material.	Bearings, seal rings
BEAREE FL 3030	PTFE	7	70	Suitable material for the soft material.	Sliding bearings, seal rings
BEAREE FL 3700	PTFE	7	70	Suitable for use in water.	Bearings in water
BEAREE PI 5001	PI	50	500	Suitable for conditions of high <i>PV</i> .	Bearings, seal rings
BEAREE AS 5000	PPS	20	200	Standard material for extrusion forming.	Parts for standard office equipment
BEAREE DM5030	POM	10	100	Highly economical for the low <i>PV</i> .	Parts for standard office equipment
BEAREE NY 5000	PA	20	200	Highly economical for the low <i>PV</i> .	Parts for standard office equipment
BEAREE UH 3000	PE	5	50	Highly economical for the low <i>PV</i> .	Parts for standard office equipment

Allowable face pressure is the value at normal temperature.

Refer to page 51 for the allowable face pressure under the high temperature atmosphere.

Refer to the test data.

BEAREE FL3000····page 55

BEAREE PI5001····page 56









4-2 Sliding materials for soft mating materials

The wear resistance of sliding bearing material itself is naturally required, but it is also necessary not to abrade the mating materials. Ordinary plastic materials sometimes abrade deeply the soft mating materials such as stainless steel, aluminum and brass.

<Feature>

- Does not abrade the soft mating materials (See table 2).
- Superior wear resistance
- Superior chemical resistance
- Superior electrical insulation properties
- Stable coefficient of friction

Table 2 Wear test (PV value: 21 MPa·m/min. No lubrication)

Shaft Material	Before the test	After the test	
		BEAREE FL 3030	PTFE filled with 25% glass fiber
Aluminum		 1000 hours	 1 hour
Brass		 1000 hours	 1 hour
SUS304 Stainless steel		 1000 hours	 1 hour

NTN developed the following materials to solve the above noted problem.

Table 3 Allowable pressure and wear factor

Grade	Properties Base Resin	Allowable pressure		Applications	Production
		MPa	kgf/cm ²		
BEAREE FL 3030	PTFE	7	70	Sliding bearings	Machining
BEAREE FL 3040	PTFE	7	70	Elevator guide shoe	Machining
BEAREE FL 3050	PTFE	7	70	High temperature bearings	Machining
BEAREE PI 3018	PI	50	500	Sliding bearings	Injection molding
BEAREE AS 5000	PPS	20	200	Office machine parts	Injection molding
BEAREE AS 5005	PPS	20	200	Office machine parts	Injection molding
BEAREE AS 5050	POM	10	100	Office machine parts	Injection molding
BEAREE DM 5010	PEEK	35	350	Seal ring for the aluminum cylinder	Injection molding



Photograph 1
Products for the soft mating materials

Refer to the test data.

BEAREE FL3000 ···· page 55

BEAREE PI5001 ···· page 56

4-3 Sliding materials for use in water or chemicals

Even materials designed and suitable for exposure to air (dry) may experience premature wear and damage to the mating material. NTN has developed materials to solve these problems.

<Applications>

- Bearing for under water (including sea water)
- Chemical pump, medical liquid pump
- Vane, rotor and casing for vane pump
- Bearing for sewage processing system

Table 4 Allowable pressure and features

Grade	Allowable pressure Mpa {kgf/cm ² }	Features
BEAREE FL 3700	7 {70}	Superior wear resistance under light load
BEAREE PI 3700	100 {1,000}	For heavy load
BEAREE AS 5700	20 {200}	Mass productivity and flexibility of part shape is possible through injection molding

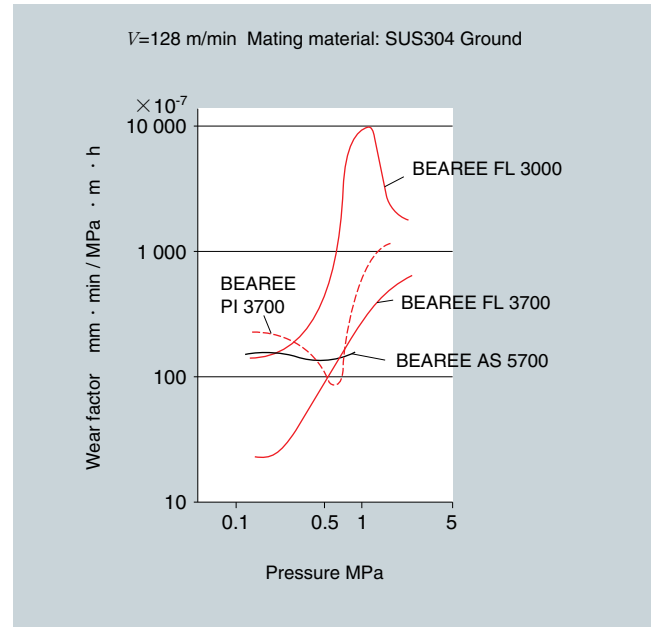

Figure 1 Wear under water test by thrust type test rig



Photograph 2 The sliding bearings use for water (chemical)

4-4 Materials for food processing equipment

So far, any material has failed to fully satisfy the functions required of a sliding material for food processing machinery. For example, an allowable operating temperature range with super molecular weight polyethylenes is small, while natural PTFE have a higher friction coefficient and are not aesthetically acceptable. Our novel fluoro resin "BEAREE FL 3642" is a unique material that positively solves these problems.

■ “Plastic Container or Wrapping Standard Test (Japan Food Research Laboratories)” approved.

- ◆ Test conditions; Ring-on-disk tester
 - Bearing pressure : 0.98 MPa
 - Peripheral speed : 32 m/min
 - Mating material : SUS304
 - Lubrication : dry or water
 - Test duration : 50 hrs.

<Features>

1. Low friction
2. Superior wear resistance
3. High allowable PV value
4. Less stick-slip phenomena at start up or extremely low speed
5. Better non-abrading characteristics against mild steel or stainless steel
6. Hygienic tone -pale yellow
7. Super chemical resistance

<Applications>

- Food processing machine
- Pharmaceutical production equipment
- Food or beverage vending machine

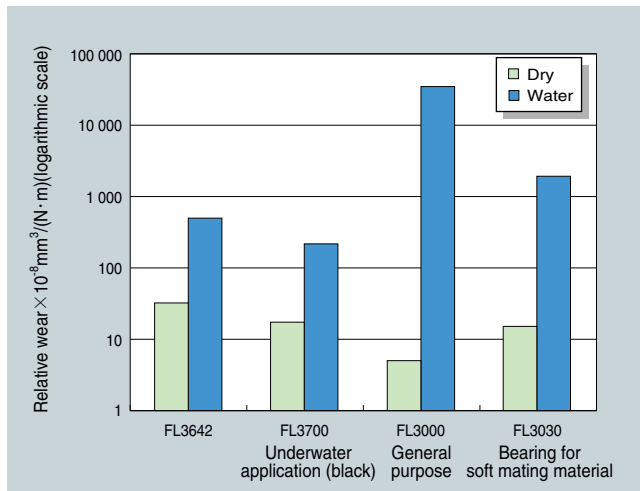

Figure 2 Comparison of wear resistance of FL3642 with other NTN bearing materials

We also have approved materials other than BEAREE FL 3642 which are suitable for each operation condition.

Table 5 Major “Plastic Container or Wrapping Standard Test ” approved material

Grade	Color	Applications
BEAREE FL 3040	Black	Bearing for soft mating material
BEAREE FL 3700	Black	Under water application
BEAREE UH 3000	White	Excellent friction / wear characteristics under low PV value
BEAREE AS 5000	Light brown	High temperature, suitable for mass production



Photograph 3 BEAREE FL 3642 Products



Photograph 4 Products for food processing equipment

4-5 Rubber with sliding capability

This material has both the elasticity of rubber and the sliding characteristics of fluoro plastics, and the following features.

<Features>

1. The elastic material seals well.
2. Superior chemical resistance (Refer to Table 21 on page 45)
3. Superior heat resistance (allowable continuous service temperature is 230°C)
4. Low friction coefficient and excellent wear resistance
5. Superior creep resistance
6. Excellent non-stick quality
7. Can be used for food contact application

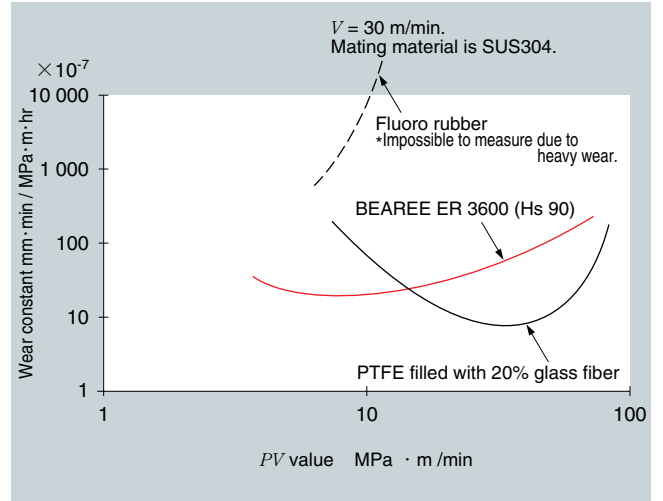

Figure 4 PV value versus wear factor

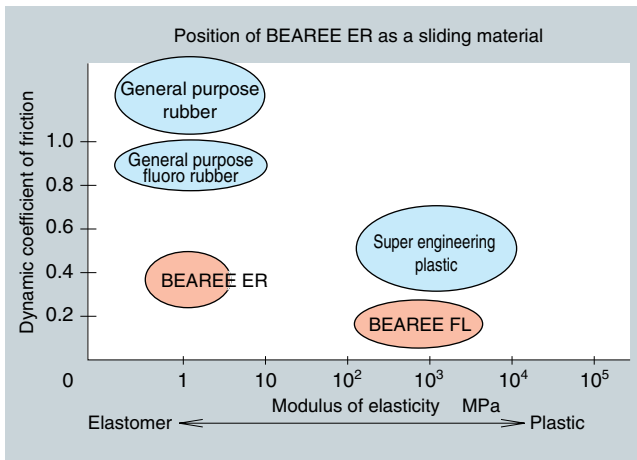

Figure 3 Position of BEAREE ER as a sliding material



Photograph 5 Sliding rubber products

Table 6 Features and applications of BEAREE ER

Grade	Hardness	Color	Features	Applications
BEAREE ER 3000	Hs 70	Black	Wear resistance	Bearings
	Hs 80			
	Hs 90			
BEAREE ER 3600	Hs 70	White	Superior sliding characteristics against soft mating material	Seals and bearings for food processing machinery
	Hs 80			
	Hs 90			

Refer to the test data.

BEAREE FL3000 . . . page 55

4-6 NBR rubber with sliding capability : BEAREE ER3200

Using acrylonitrile butadiene rubber (NBR) as a base material, BEAREE ER3200 boasts low friction, low wear resistance characteristics while maintaining advantages of rubber material.

<Features>

1. Excellent friction and wear characteristics
2. Retains advantages of rubber material.
3. Better ozone resistance than general purpose NBR
4. Capable of composite molding together with metal material, etc.
5. More economical than sliding-capable fluoro rubber (such as BEAREE ER3000)

<Applications>

Field	Applications
Automobile	Glassran Wiper blade Shock absorber seal
Office equipment (photocopier, printer)	Cleaning blade Toner seal Paper feed roller Mirror slider
Industrial machinery	Mechanical seal in wet environment Grease seal Oil seal Gas seal Seal for damper

<Wear resistance>

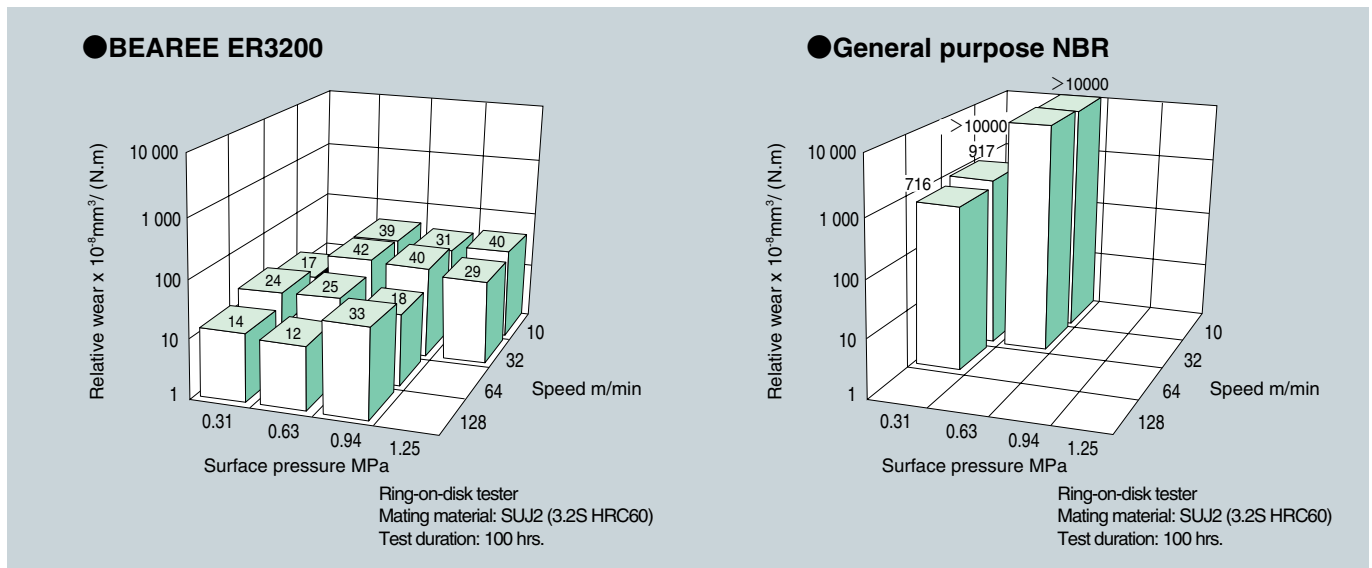

<Wear resistance>

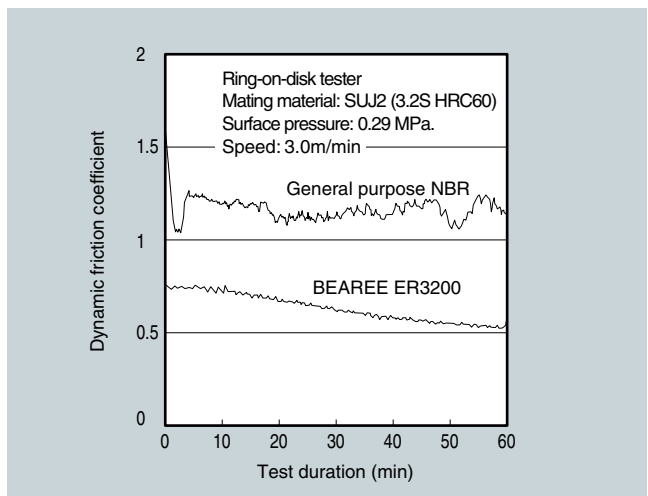

<Basic characteristics>

Item	Test method	Unit	Measurement
Hardness	JIS-K6253	JIS-A	70
Specific gravity	JIS-K6220	—	1.33
Tensile strength	JIS-K6251	MPa	11
Elongation	JIS-K6251	%	430
Tearing strength	JIS-K6252	N/cm	294
Permanent set	JIS-K6262	%	11
Compression set 120°C, 70 hrs.	JIS-K6262	%	24
Ozone resistance 40°C, 50 Pphm 96 hrs., elongation 20%	JIS-K6259	—	No fissure

**4-7 Sliding materials with electrical conductivity
(Preventing electrostatic charges)**

This material has not only excellent friction and wear characteristics but also has electrical conductivity. Utilizing this material as bearings for which anti-static properties are required, the grounding device could be removed.

Unlike conventional carbon brushes, these materials are less prone to cracking or chipping. They also operate more quietly.

<Applications>

- Sliding and grounding parts for computer related equipment.
- Bearings, gears for photo copiers, printers and facsimile machines.

Table 7 Volume resistivity and major applications

Grade	Volume resistivity ($\Omega \cdot \text{cm}$)	Major applications
BEAREE FL 3900	10	Grounding button for disk drive
BEAREE PI 5040	1×10^5	Gear
BEAREE AS 5950	5×10^5	Bearing
BEAREE AS 5951	1×10^4	Bearing
BEAREE NY 5910	10	Gear
BEAREE NY 5911	1×10^3	Gear

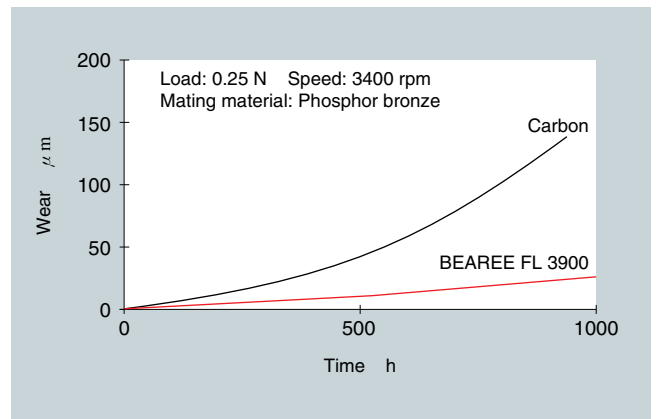

Figure 5 Wear comparison between BEAREE FL 3900 and Carbon



Photograph 7 Conductive bearings, gears



Photograph 6 Grounding buttons for disk drivers

4-8 Sliding materials for high contact pressures

In general, the allowable pressure for plastics material is low when compared with metal material; however, it can be used under high pressure by bonding it to a backing metal or using a thin layer of plastics which is reinforced with filler.

1. BEAREE PI

The BEAREE PI series, with a base resin of polyimide, can carry 50 to 100 MPa of allowable pressure. The grade to be adopted is selected according to temperature, sliding velocity and manufacturing method.

Table 8 Allowable pressure and manufacturing method

Grade	Allowable pressure MPa {kgf/cm ² }	Manufacturing method
BEAREE PI 5001	50 { 500 }	Extrusion forming
BEAREE PI 7000	250 { 2,500 }	Coating

<Applications>

- Non lubrication type pillow block
- Anchor bearing for buoy
- Transmission thrust bearings

Refer to the test data.

BEAREE P15001 ···· page 56

2. BEAREE FL 9000

This material can carry up to 200 MPa of pressure under low speed conditions.

The bronze mesh in this material prevents creep, and makes it possible for use in high pressure applications.

Figure 21 shows the section view of this material. Compact design can be achieved due to its thickness of 0.5mm. It is recommended to bond this material to a stiff material like metal in applications where the pressure is higher than 40 MPa.

Table 9 Allowable pressure and Structure

Grade	Allowable pressure MPa {kgf/cm ² }	Structure
BEAREE FL 9000	100 { 1,000 }	PTFE containing mesh gauze

<Applications>

- Non lubrication type spherical plain bushing
- King-pin bearing
- Crane
- Shock absorber
- Door hinge

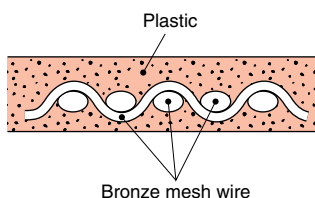

Figure 6 Structure of BEAREE FL9000

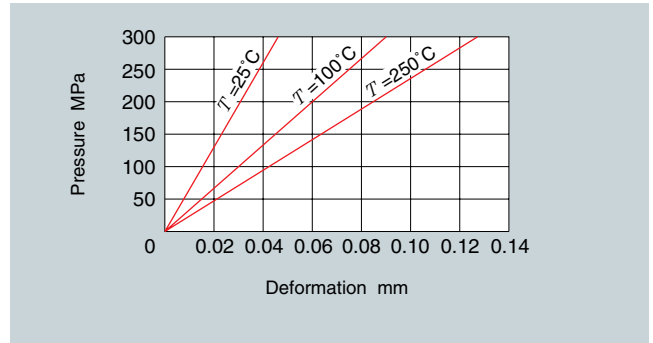

Figure 7 Deformation (compressive strain) by load (pressure)

Remarks:

The deformation is measured while BEAREE FL 9000 is clamped between steel plates with load applied for 60 minutes. The deformation lowers or, is reduced, when BEAREE FL 9000 is bonded to backing material.

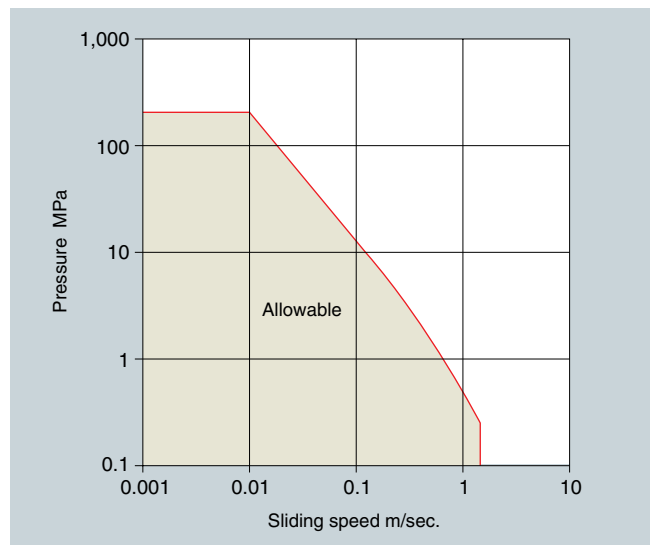

Figure 8 Allowable PV value-BEAREE FL9000



Photograph 8 The sliding bearings for high pressure (load)

4-9 Sliding materials for use in machine tools : BEAREE FL 3305

BEAREE FL 3305, which is based on fluoro plastics with a low friction coefficient, and designed with improved wear and creep resistance and thermal conductivity, is material developed exclusively for machine tools and has the lowest friction coefficient when lubricated with oil.

<Features>

1. The lowest coefficient of friction under oil lubrication.
2. No stick-slip.
3. No galling and/or seizure
4. Little compressive deformation
5. No oil film shortage problem at startup; suitable for frequent startups.
6. Low coefficient of friction and durable.

<Remarks>

Standard thickness:mm
0.3,0.4,0.5,0.6,0.8,1.0,1.2,1.5,2.0,2.5,3.0

Reciprocating friction test (Fig.9, Fig.10)

Mating material : Mihanite cast iron(0.3S grinding finish)
Stroke : 60 mm
Lubrication : Application of Shelltoner T68.

High speed reciprocating friction test
Mating material : Mihanite cast iron (0.3S grinding finish)
Sliding speed : 30 m/min.
Stroke : 200 mm
Lubrication : Application of mineral oil.

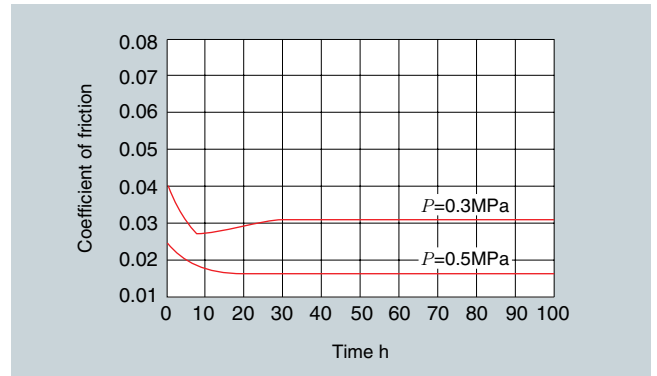

Figure 11 Friction coefficient versus running time

Use the original adhesive for easy bonding.

1. N-3 bonding agent : High hardness after hardening.
2. AD-3000 bonding agent : Hardness after hardening is lower than N-3 so that the cutting work is easy.

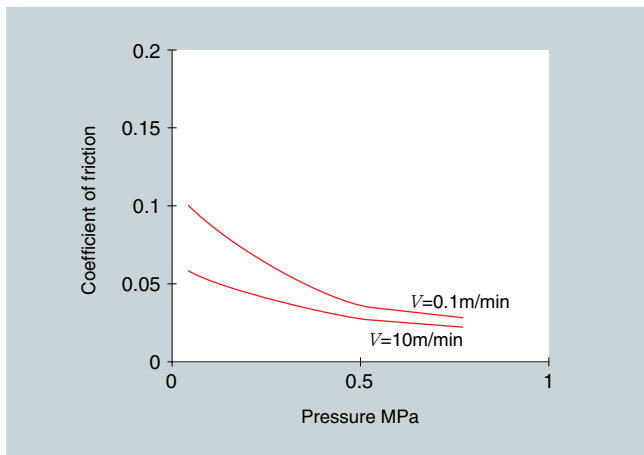

Figure 9 Friction coefficient versus face pressure

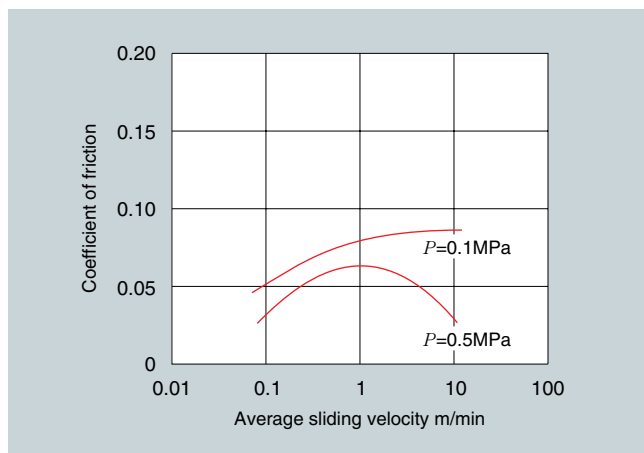
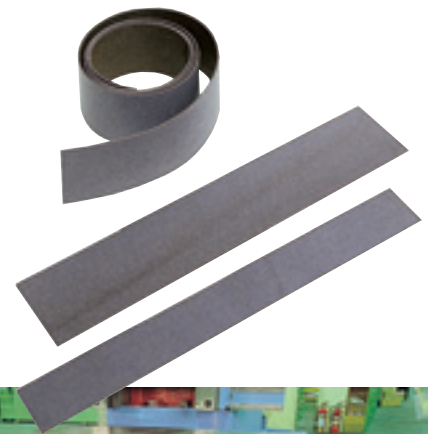

Figure 10 Friction coefficient versus sliding velocity



Photograph 9 Sliding section of machine

4-10 Plastics materials for gears

Plastics gears are used in various areas due to their light weight, no need for lubrication, low noise, corrosion resistance and ease of mass production. NTN Engineering Plastic materials for gears are widely prepared for particular applications or functions, from super engineering plastic to general purpose engineering plastic to ensure the optimum gear.

<Features>

1. High strength, durable
2. Superior sliding properties
3. Superior heat resistance

<Typical configuration>

Gear type: flat gear, helical gear
 Module : 0.8 ~ 1.5
 P.C.D . : 15 ~ 60mm

Table 10 Gear material and features

Grade	Base Resin	Performance Evaluation			
		Heat resistance	Sliding capability	Strength	Electrical conductivity
BEAREE PI 5030	PI	◎		◎	
BEAREE PI 5033		◎		◎	
BEAREE AI 5006	PAI	◎		◎	
BEAREE AS5040	PPS	○		◎	
BEAREE AS5045		○	○	○	
BEAREE NY5010	PA			○	
BEAREE NY5910			○	○	○

◎:Excellent ○:Normal

* Material is selected by operating condition, material of mating gear, life, tolerances and so on.



Photograph 10 Gears

- A:** Anti-rotation type (D bore)
- B:** Anti-rotation type (With key)
- C:** Idler gear (Made of sliding material)
- D:** Idler gear (Compound type sliding material on bore)
- E:** Double gear
- F:** Helical gear

4-11 Materials for separating pins

Photocopiers and printers fix the image formed by toner to the paper by heating and pressing of rollers. To peel off the attached paper from the roller, sharp separating pins are used. For the separating pins, rigidity at a high temperature, sliding properties so as to not to scratch the roller, and superior anti-stick properties are necessary. NTN Engineering Plastics provides a suitable pin and coating materials for the practical temperature.

<Characteristics>

- Excellent mechanical strength and heat resistance.
- Satisfactory fluidity and excellent performance in molding the pin tip figure.
- Excellent shock resistance.
- Superior friction and wear resistance.

Table 11 Combination of the separating pin material and recommended coating material.

Material name	Maximum operating temperature °C	Recommended coating material	Application
BEAREE PI 5022	300	BEAREE FE 7092	Pins for the fixing section, high performance.
BEAREE LC 5020	300	BEAREE FE 7090	Pins for the fixing section.
BEAREE AI 5017	230	BEAREE FE 7030	Pins for the fixing section.
BEAREE AI 5003	230	BEAREE FE 7030	Pins for the exposure drum.
BEAREE AS 5021	230	BEAREE FE 7080	Pin for the fixing section, highly economic.
BEAREE AS 5025	230	—	Pin for the fixing section, highly economic.

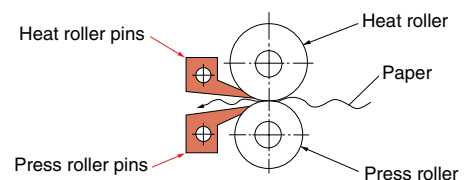

Fig.12 Application of separating pins

4-12 Sliding materials for the guide roller

As the guide roller for the high speed running of video tape recorders (VTR), computer backup devices and digital audio tape recorders (DAT), BEAREE UH 5041 presents a wide range of superior friction and wear properties with less torque change from the tape's low speed running to high speed running.

Table 12 Materials and Characteristics

Material name	Base resin	Characteristics
BEAREE UH5041	PE	<ul style="list-style-type: none"> · Low revolution torque at high speed rotation · Constant revolution at low speed rotation · Superior durability in many environmental conditions

Test conditions (Revolution torque test)

Test unit : Revolution torque
 measurement unit
 Test sample : Guide roller
 Load : 0.3N{30gf}
 Revolution : 100-21,000 rpm
 Lubrication : None
 Ambient temp : Room temperature

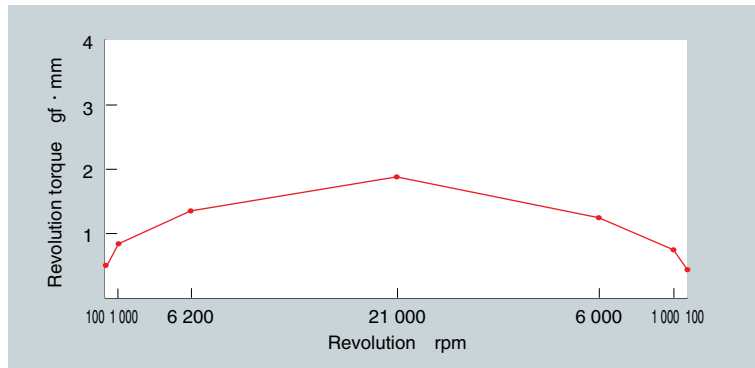

Fig.13 Revolution torque of guide roller versus revolution

Test conditions (Endurance test)

Test sample : Guide roller
 Load : 0.3N{30gf}
 Revolution : 25 000 rpm
 (Revolution for measurement of torque: 18,000 rpm)
 Lubrication : None
 Ambient temp : Room temperature
 Operation pattern : Clockwise/
 counterclockwise revolution
 Test time : 1,000 hours

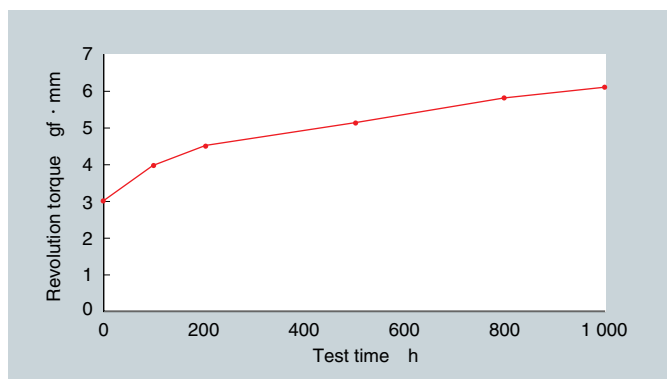

Fig.14 Revolution torque of guide roller versus test time

4-13 Seal materials for sliding applications

NTN Engineering Plastics have excellent sealing capabilities against gas and liquid, good wear resistance, and low friction characteristics.

<Features>

1. Superior sealing capability due to the high compliance.
2. Low coefficient of friction and superior wear resistance
3. No lubrication is necessary due to the self lubricating capability.
4. Superior chemical resistance; can be used in corrosive environments.

(See **Table 9** at page 17 for chemical resistance.)

Table 13 Selection and Applications

Grade	Mating material			Atmosphere			Elongation (%)	Processing Method	Application
	Mild steel	Cast iron	Aluminum	Dry	Oil	Water			
BEAREE FL 3000	○	○	×	○	○	△	200	Machining	General purpose, power steering A/T transmission
BEAREE FL 3030	○	○	○	○	○	×	170	Machining	Air suspension Air compressor
BEAREE FL 3050	○	○	○	○	○	△	160	Machining	Air suspension Air conditioner compressor
BEAREE FL 3070	○	○	○	×	○	△	230	Machining	Car air conditioner A/T transmission
BEAREE FL 3900	○	○	×	×	○	△	34	Machining	A/T transmission
BEAREE AS 5001	○	○	○	△	○	△	1.0	Injection molding	Scroll compressor
BEAREE AS 5700	○	○	○	△	○	○	2.0	Injection molding	Vane under water
BEAREE PK 5015	○	○	○	×	○	△	1.1	Injection molding	Scroll compressor
BEAREE PK 5300	○	○	○	×	○	○	1.3	Injection molding	A/T transmission

○: Satisfactory △:Normal ×:Unsuitable

Refer to the test data.

BEAREE FL3000·····page 55



Photograph 11 Seal rings

4-14 Sound damping material for curtain walls

Tall buildings constructed with curtain wall structures require a sliding material to smooth the relative movement between the steel frame and other building materials. Movement caused by differences in thermal expansion,

earthquakes, wind, etc. is smoothed, eliminating jarring sounds. NTN Engineering Plastics include materials for this purpose.

Table 14 Features

Grade	Features	
BEAREE FL 3000	<ul style="list-style-type: none"> Low coefficient of friction with no lubrication Prevention of jarring sound between metals High load carrying capability Superior weather resistance Resistant for most of chemicals 	<ul style="list-style-type: none"> Fire or flame retardant capability Superior electric insulating characteristics
BEAREE UH 3954		<ul style="list-style-type: none"> Superior shock resistance
BEAREE FL 7075		<ul style="list-style-type: none"> Can be applied in this layers to complicated shapes

Refer to the test data.

BEAREE FL3000 . . . page 55

BEAREE FL7075 . . . page 57

<Remarks>

- Thickness (Unit in mm)
 - BEAREE FL 3000 0.3, 0.4, 0.5, 0.6, 0.8, 1.0
 - BEAREE UH 3954 0.1, 0.3, 0.4, 0.5, 1.0
 - BEAREE FL 7075 0.02 (Coating layer)
- Pressure sensitive adhesive

Product with pressure sensitive adhesive on one side is available
- To place your order

Specify $A \times B \times$ thickness, hole dimension (d or $C \times D$), material and requirements for pressure sensitive adhesive.

Specify the surface to be coated for coating product (BEAREE FL 7075), or the coating of your product is also available.

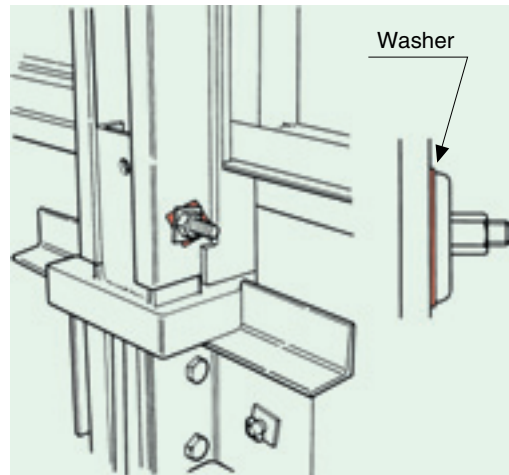
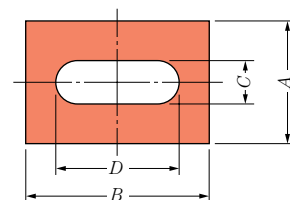
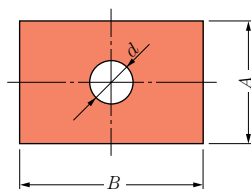
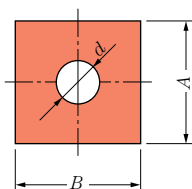

Fig.15 Sound dampening washer of the curtain wall.



<Applications>

- Fastener
- Liner
- Bracket
- Joint sleeve
- Shaft
- Hinge washer
- Other metal sliding portion.

4-15 Sliding materials for bridges and anti-earthquake structures

A bridge repeatedly expands and contracts due to daily and seasonal temperature changes. One side of the bridge bearings smoothly slides with the bridge to relieve the generated stress on the bridge.

An anti-earthquake device has a mechanism to reduce an earthquake's power by sliding the building according to the earthquake's intensity. As one means to slide the building, sliding materials are utilized. For these bridges and anti-

earthquake devices, BEAREE FL3020 is used, which is excellent for big loads with low friction and resistant to the climate changes.

Table 15 Materials and Characteristics

Material name	Base resin	Characteristics
BEAREE FL 3020	PTFE	<ul style="list-style-type: none"> · Low friction coefficient under the high surface pressure · Superior durability in many environmental conditions

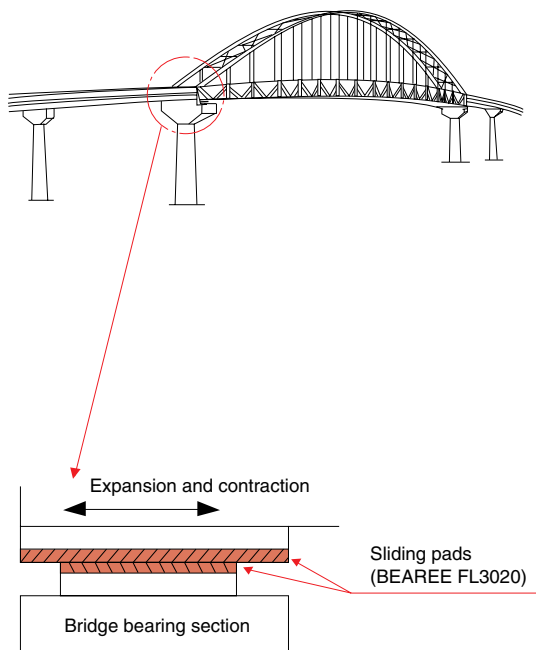

Fig.16 Sliding pad for bridge bearings

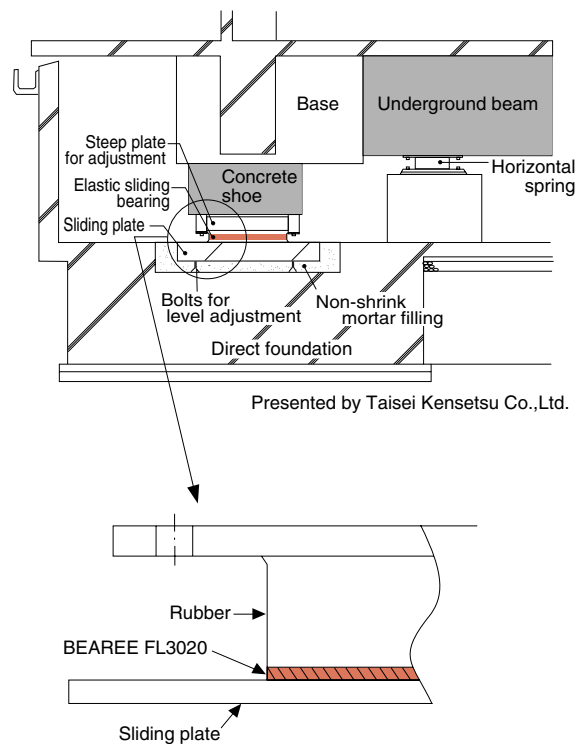

Fig.17 Anti-earthquake device with the elastic sliding bearing
Presented by Tokyo Fabric Industry Co.,Ltd.

4-16 Compound products

By combining BEAREE materials with other materials, the advantages of each material can be utilized.

<Features>

1. Allowable pressure can be increased.
2. Reinforcement material can be selected by application.
3. Weight can be reduced.
4. Thermal expansion can be decreased.
5. Processing accuracy can be improved.
6. Compact design is available by integrating the mating housing.
7. Number of components can be decreased.

<Applications>

Copying machine: Heat roller bearing, pressure roller and mirror slide bearing

Printer carriage bearing

Slide bearing for data recorder

Seal ring for automobile

Door guide shoe for elevator

<Examples of composite>

- BEAREE material + Rubber
- BEAREE material + Rubber + Metal
- BEAREE material + Metal
- BEAREE material + General implantation + Metal



Photograph 12 Composite products

4-17 Coating materials

BEAREE coating material provides a hard, thin and uniform layer, and is applied to the location where thermal expansion should be small or precision is required.

Also, the characteristics of wear resistance and non-stick quality can be utilized.

Coating methods such as spray, powder coating, dipping, etc., are adopted according to the kind of material.

<Features>

1. Superior wear and friction characteristics
2. Superior non-stick quality
3. Superior heat resistance
4. Superior chemical resistance

Table 23 Materials for coating and its characteristics

Grade	Characteristics			Remarks	Baking temperature (°C)	Layer thickness (μm)	Applications
	Low coef. of friction	Wear resistance	non-stick quality				
BEAREE FL 7060	○	○		Superior under low pressure	230	10~30	Guide pin
BEAREE FL 7061	○	○		For oil lubricated	230	10~30	Reciprocating bearing in oil
BEAREE FL 7075	○	○		General purpose	230	10~30	Piston, washer vane
BEAREE FE 7010		○		For high pressure, thick layer	315	500~2 000	Rotor for super charger
BEAREE FE 7080	○		○	Extremely thin layer	150	Below 1	Guide pin, picker for copier
BEAREE FE 7000	○	○		For high pressure	230	300	Bearing
BEAREE FE 7030			○		230	10~30	Slide guide picker finger for copier
BEAREE FE 7090			○		370	10~30	Picker finger for copier

* Can be coated on plastics as well as metals; however, the plastics should be resistant to the baking temperature of coated BEAREE.

* Surface treatment of BEAREE FE7080 is processed in the range from room temperature up to 250°C.

Refer to the test data.

BEAREE FL7075 page 57

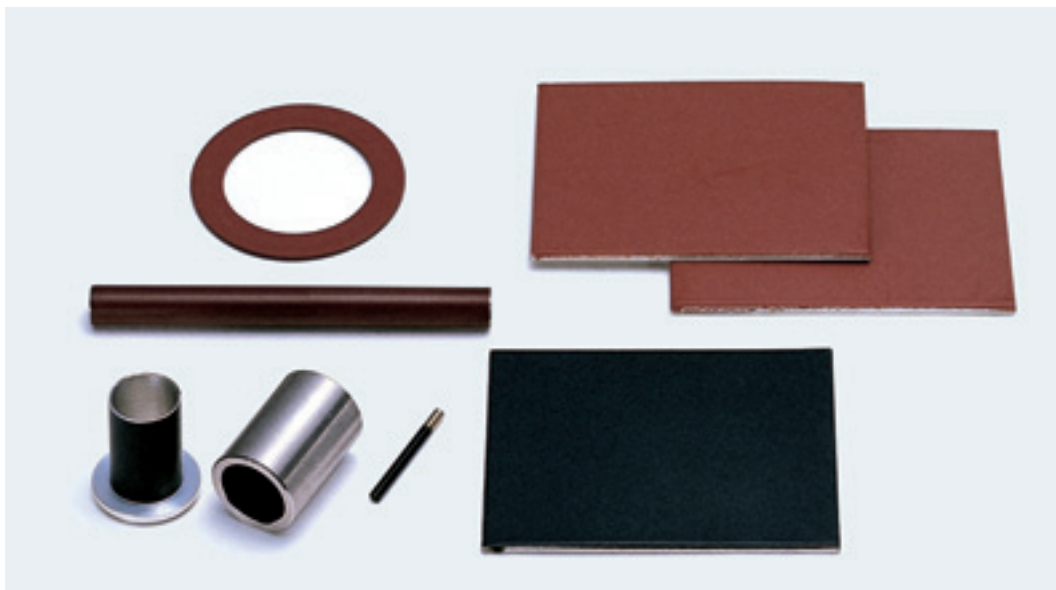

Photograph 13 The coated products

5

Materials for Bearing Applications

5-1 Various grades and their characteristics

Table 17 Materials for machining (ram extrusion and compression molding)

Grade	Base Resin		Characteristics	Applications
BEAREE FL 3000	PTFE		*Less deformation under compression load *Superior wear, resists friction	*Sliding bearings *Valve seats *Piston rings
BEAREE FL 3020	PTFE		*Low friction under high pressure *Superior weather resistance	*Bearing pads
BEAREE FL 3030	PTFE		*Does not abrade soft mating material *Stable coefficient of friction	*Sliding bearings *Seal rings *Piston rings, friction plate
BEAREE FL 3040	PTFE		*Does not abrade soft mating material	*Sliding bearings *Piston cup seals
BEAREE FL 3050	PTFE		*Does not abrade soft mating material *Superior wear resistance under high temperature	*Sliding bearings
BEAREE FL 3060	PTFE		*Superior creep resistance	*Exclusively for ML bearings
BEAREE FL 3070	PTFE		*Superior sliding characteristics and creep resistance	*Compressor seals
BEAREE FL 3305	PTFE		*Low coefficient of friction under oil lubrication	*Sliding table for machine tools
BEAREE FL 3641	PTFE		*Passed regulations for food processing equipment *Superior wear resistance	*Sliding bearings *Seals
BEAREE FL 3700	PTFE		*Superior under water wear resistance *Superior chemical resistance	*Bearings for under water and /or chemical liquid
BEAREE FL 3900	PTFE		*Conductive (Volume resistive: $10 \Omega \cdot \text{cm}$) *Superior wear, resists friction	*Grounding buttons *Brushes
BEAREE UH 3000	PE		*Superior friction resistance and wear under low PV value *Superior shock resistance	*Sliding bearings *Washers
BEAREE UH 3954	PE		*Effective for anti-static *Less abrasion wear (Wear from paper or sand lapping)	*Sound damping washers *Cassette tape shims
BEAREE FL 9000 ²⁾	PTFE		*Suitable under low speeds high pressures	*Sliding bearings *Rocking bearings
BEAREE ER 3000	E ¹⁾		*Has elasticity and low friction *Superior sealing anti-stick property and chemical, heat wear and creep resistance	*Food processing equipment seals
BEAREE ER 3600	E ¹⁾		*Meets regulations for rubber packaging and containers *Sliding bearings	

NOTE 1) E : Elastomer

2) BEAREE FL 9000 is the special material for tapes.













Specific gravity	Compressive creep %	Hardness ¹⁾	Tensile strength		Elongation %	Flexural strength		Flexural modulus		Water absorption %	Coef. of thermal expansion ²⁾ × 10 ⁻⁵ /°C	Max. service temp. °C
			MPa	kgf/cm ²		MPa	kgf/cm ²	MPa	kgf/cm ²			
2.28	8.1	66	15	150	200	—	—	—	—	0.03	8.3	260
2.23	7.0	64	22	220	250	—	—	—	—	0.03	—	260
1.98	5.0	62	12	120	170	—	—	—	—	0.09	9.0	260
2.19	6.0	63	14	140	170	—	—	—	—	0.02	8.5	260
1.94	6.0	63	11	110	160	—	—	—	—	0.01	8.7	260
3.80	3.2	70	10	100	100	—	—	—	—	0.09	6.8	260
2.09	—	68	18	180	230	—	—	—	—	—	6.3	260
3.39	4.0	70	11	110	90	—	—	—	—	—	6.8	260
2.25	10.6	65	13	130	140	—	—	—	—	0.02	9.1	260
2.10	3.0	70	16	160	130	—	—	—	—	0.07	7.2	260
2.07	1.4	70	14	140	30	—	—	—	—	—	8.7	260
0.94	11.0	65	20	200	200	20	200	610	6 100	0.01	20.0	80
0.94	10.0	65	40	400	200	—	—	—	—	0.01	17.0	80
4.25	—	—	46	460	15	—	—	—	—	—	1.9	260
1.78	—	Hs70,80,90	10	100	290	—	—	—	—	0.05	10.0	230
2.10	—	Hs70,80,90	12	120	290	—	—	—	—	0.05	10.0	230

NOTE 1) Hardness: no code = durometer; Hs = rubber hardness; others = Rockwell hardness

2) Coefficient of linear expansion: the mean coefficient of linear expansion in the range from room temperature up to 150°C.

Values in the above table are representative test results.

Table 18 Injection molding materials

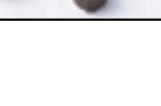
Grade	Base Resin	Characteristics		Applications
BEAREE PI 5001	PI		*Excellent wear resistance	*Sliding bearings *Washers *Piston rings
BEAREE PI 5010	PI		*Non-abrasive to soft mating materials	*Sliding bearings *Thrust bearings
BEAREE PI 5022	PI		*Precision moldable	*Picker fingers *Electrical and electronic parts
BEAREE PI 5030	PI		*High mechanical strength	*Gears *Retainers (bearing cages)
BEAREE PI 5040	PI		*High rigidity and electrical conductivity	*Gears *Heat insulating sleeves
BEAREE AI 5003	PAI		*Excellent impact resistance *High mechanical strength	*Heat insulation *Electrical and electronic parts
BEAREE AI 5017	PAI		*Excellent friction and wear properties *High mechanical strength *Small drop in heat resistance due to water absorption	*Picker fingers *Sliding bearings *Washers
BEAREE UH5000	PE		*Excellent impact resistance *Excellent resistance against abrasive wear	*Sliding bearings
BEAREE UH5041	PE		*Excellent sliding properties at low pressure	*Guide rollers
BEAREE AS5000	PPS		*Excellent sliding properties at high temperature *High max. allowable bearing pressure ($P_{max} = 20$ MPa) *Non-abrading soft mating material	*Sliding bearings *Friction plates *Reciprocating bearings
BEAREE AS5005	PPS		*Excellent sliding properties at high temperature *High max. allowable bearing pressure ($P_{max} = 20$ MPa) *Non-abrading soft mating material	*Sliding bearings
BEAREE AS5021	PPS		*Excellent strength for separating pins	*Picker fingers
BEAREE AS5053	PPS		*Excellent sliding properties at high temperature	*Fixing roller bearing
BEAREE AS5961	PPS		*Excellent sliding properties at high temperature	*Fixing roller bearing

Specific gravity	Compressive creep %	Hardness ¹⁾	Tensile strength		Elongation %	Flexural strength		Flexural modulus		Water absorption %	Coef. of thermal expansion $\times 10^{-5}/^{\circ}\text{C}$ ²⁾	Max. service temp. $^{\circ}\text{C}$ ³⁾
			MPa	kgf/cm ²		MPa	kgf/cm ²	MPa	kgf/cm ²			
1.49	—	M94	67	670	1.3	108	1 080	8 500	85 000	0.10	2.2	240(300) ³⁾
1.46	<0.2	M70	76	760	7	116	1 160	3 700	37 000	0.25	4.5	240(300) ³⁾
1.80	—	M107	138	1 380	1	190	1 900	14 100	141 000	0.3	3.4	240(300) ³⁾
1.58	<0.2	M99	160	1 600	3	250	2 500	11 000	110 000	0.22	1.5	240(300) ³⁾
1.43	<0.2	M99	130	1 300	2	360	3 600	21 000	210 000	0.25	0.4	240(300) ³⁾
1.40	<0.2	E91	190	1 900	12	220	2 200	4 700	47 000	0.28	4.0	250
1.51	<0.2	M105	82	820	—	170	1 700	8 800	88 000	0.18	4.1	250
0.94	11.0	R60	41	410	10	41	410	1 600	16 000	0.01	17.0	80
0.95	—	—	48	480	8.8	33	330	970	9 700	0.06	12.4	80
1.53	0.3	80	51	510	3	61	610	—	—	0.05	8.1	230
1.55	0.3	81	51	510	3	61	610	—	—	0.03	7.0	230
1.69	—	—	103	1 050	—	164	1 670	11 760	120 000	0.01	—	230
1.60	—	R95	67	670	4	86	860	3 700	37 000	—	10.8	230
1.56	—	R91	51	510	5	80	800	3 600	36 000	—	7.5	230

NOTE 1) Hardness: no code = durometer; others = Rockwell hardness

2) Coefficient of linear expansion: the mean coefficient of linear expansion in the range from room temperature up to 150°C.

3) Max. service temperature shown in brackets (): for the products after crystallizing treatment

Values in the above table are representative test results.

Table 18













Grade	Base Resin	Characteristics		Applications
BEAREE AS5700	PPS		*Superior wear resistance in water *Superior chemical resistance	*Bearings in water *Bearings in chemicals
BEAREE AS5910	PPS		*High modulus	*Lens holders
BEAREE LC5020	ARPES		*High mechanical strength high heat resistance *Picker fingers mold well because of material's fluidity	*Picker fingers
BEAREE PK5030 ⁴⁾	PEEK		*Excellent wear resistance	*Washers
BEAREE PK5900	PEEK		*Excellent wear resistance *Superior shock resistance	*Sliding bearings *Bearings in oil
BEAREE PK5300	PEEK		*Excellent wear, friction, chemical and heat resistance *Superior sealing	*Seal rings
BEAREE NY5000	PA		*Excellent friction and wear characteristic at low PV value	*Sliding bearings *Door wheels
BEAREE DM5030	POM		*Excellent wear resistance ensuring stable low friction coefficient for a long period of time *Suitable for aluminum or copper mating material	*Sliding bearings *Gears *Rollers

Table 19 Coating materials

Grade	Characteristics		Applications
BEAREE FL7075		*Excellent friction and wear characteristics *Strong coat layer	*Washers *Valve plates *Rollers
BEAREE FE7010		*Thick, strong layer is achievable	*Roots pump rotors
BEAREE FE7031		*Excellent anti-stick properties *Strong coat layer	*Picker fingers *Slide guides
BEAREE FE7080		*Accuracy of coated parts can be maintained due to extremely thin layer of coating *Excellent anti-stick properties	*Picker fingers *Sliding bearings
BEAREE FE7092		*Excellent anti-stick properties	*Picker fingers

Specific gravity	Compressive creep %	Hardness ¹⁾	Tensile strength		Elongation %	Flexural strength		Flexural modulus		Water absorption %	Coef. of thermal expansion $\times 10^{-5}/^{\circ}\text{C}$	Max. service temp. $^{\circ}\text{C}$
			MPa	kgf/cm ²		MPa	kgf/cm ²	MPa	kgf/cm ²			
1.70	—	R120	60	600	2	110	1 100	10 000	100 000	0.03	2.3	230
1.93	—	R121	41	410	1	110	1 100	35 000	350 000	0.03	1.4	230
1.82	—	—	173	1 730	3	198	1 980	23 700	237 000	—	—	300
1.30	—	—	130	1 300	100	—	—	—	—	0.13	5.0	250
1.39	—	R118	126	1 260	2	207	2 070	7 400	74 000	—	4.4	250
1.63	—	M79	82	820	1	130	1 300	9 900	99 000	—	3.0	250
1.40	0.6	68	20	200	20	—	—	—	—	—	—	100
1.42	—	—	50	500	35	80	800	2 650	26 500	—	—	100

NOTE 1) Hardness: no code = durometer; others = Rockwell hardness

2) Coefficient of linear expansion: the mean coefficient of linear expansion in the range from room temperature up to 150°C.

Values in the above table are representative test results.

Layer thickness μm	Bond strength					Max. continuous service temperature	Baking temperature	Coating method		
	Cross-cut test	Pencil hardness test		Pin scratching test	Spray coating			Dip coating	Powder coating	
		Causing scratches	Causing tear							
10~30	100/100	H	3H	5	180	230	○			
500~1 000	100/100	6H	—	5	180	315			○	
10~20	100/100	3H	5H	5	180	230	○			
<1	100/100	—	—	—	180	—	○	○		
10~20	100/100	B	H	4	330	370	○			

Values in the above table are representative test results.

Surface treatment temperature of BEAREE FE7080 performs in the range from room temperature up to 250°C.

Table 20 Testing methods for each property

	Unit	Testing methods				
		Fluoroplastic based material	General plastics	Rubber	Coating	FL3020
Specific gravity	—	ASTM D792	ASTM D792	JIS K6350	—	JIS K6888
Compressive creep	%	ASTM D621	ASTM D621	JIS K6301	—	—
Hardness		ASTM D2240	ASTM D785	JIS K6301	—	JIS K7215
Tensile strength	MPa kgf/cm ²	ASTM D638	ASTM D638	JIS K6301	—	JIS K6888
Elongation	%	ASTM D638	ASTM D638	JIS K6301	—	JIS K6888
Flexural strength	MPa kgf/cm ²	—	ASTM D790	—	—	—
Flexural modulus	MPa kgf/cm ²	—	ASTM D790	—	—	—
Compressive strength	MPa kgf/cm ²	ASTM D695	ASTM D695	JIS K6301	—	JIS K7208
Water absorption	%	ASTM D570	ASTM D570	JIS K6301	—	JIS K7209
Coef. of thermal expansion	× 10 ⁻⁵ /°C	TMA method	TMA method	TMA method	—	—
Cross-cut	Score (0~10)	—	—	—	JIS K5400	—
Pencil hardness	Pencil hardness	—	—	—	JIS K6894	—
Pin scratching	Score (0~5)	—	—	—	JIS K6894	—

The material property values shown in the catalog are only representative test results obtained from the tests under specific test conditions. This data may not be directly applicable to applications under different service conditions. Those characteristic values are merely representative test results which are not to be used as specifications.

5-2 Chemical compatibility of each grade

NTN engineering plastics materials are inert against almost all chemicals. Chemical resistance of the base resins of BEAREE materials are shown in table 21.

The following table shows the characteristics of base resin on each grade, therefore they may differ according to the contained filler. Contact us for selection.

Table 21 Chemical properties of NTN Engineering Plastics materials.

Chemicals	BEAREE FL	BEAREE FE	BEAREE PI	BEAREE AI	BEAREE UH	BEAREE AS	BEAREE LC	BEAREE PK	BEAREE NY	BEAREE DM	BEAREE ER <3000type>	
Acids	Concentrated sulfuric acid	⊙	⊙	×		○	○	⊙	×	×	×	○
	15% Acetic acid	⊙	⊙	△	⊙	○	⊙	⊙	×	×	×	×
	75% Acetic acid	⊙	⊙	△	⊙	×	⊙	⊙	×	×	×	×
	Hydrochloric acid	⊙	⊙	⊙	○	⊙	⊙	⊙	×	×	×	⊙
	15% Nitric acid	⊙	⊙	○		○	○	⊙	⊙	×	×	○
	70% Nitric acid	⊙	⊙	△	×	×	×	⊙	△	×	×	○
	Formic acid	⊙	⊙	△	×	⊙	⊙	⊙	×	×	×	×
	85% Phosphoric acid	⊙	⊙	△	⊙	×	⊙	⊙	⊙	×	×	○
	40% Chromic acid	⊙	⊙			×	○	⊙	○	×	×	○
	100% Lactic acid	⊙	⊙	△	⊙	⊙	⊙	⊙	⊙	×		⊙
	Hydrogen peroxide	⊙	⊙			○	○	○	⊙	×	○	⊙
Alkali	30% Ammonia aqueous solution	⊙	⊙	△	○	⊙	○	×	○	×	○	⊙
	Iron chloride	⊙	⊙	△	⊙	⊙	⊙		⊙	○	⊙	
	Calcium chloride	⊙	⊙	⊙	⊙	⊙	⊙	⊙	⊙	○	⊙	
	Sulfate	⊙	⊙	⊙	⊙	⊙	⊙	⊙	⊙	△	○	△
	Calcium hydroxide	⊙	⊙	⊙	⊙	⊙	⊙	×	⊙	○	○	○
	Mineral water	⊙	⊙	⊙	⊙	⊙	⊙	⊙	⊙	○	○	⊙
Solvents	Methyl alcohol	⊙	⊙	⊙	⊙	○	⊙	○	×	○	○	
	Acetone	⊙	⊙	○	⊙	×	⊙	⊙	⊙	○	×	
	Benzene	⊙	⊙	○	⊙	×	⊙	⊙	⊙	○	○	
	Carbon tetrachloride	⊙	⊙	×	⊙	×	⊙	⊙	⊙	○	○	
	Ethyl-ether	⊙	⊙	⊙	⊙	×	⊙	⊙	⊙	○	×	
	Ethylene glycol	⊙	⊙	△	⊙	⊙	⊙	○	⊙	○	⊙	
Oils Kerosene	Diesel engine oil	⊙	⊙	⊙	⊙		⊙	⊙	⊙	○	○	
	Lubricating oil	⊙	⊙	⊙	⊙	×	⊙	⊙	⊙	○	⊙	
	Animal oil, Vegetable oil	⊙	⊙	⊙	⊙	⊙	⊙	⊙	⊙	○	⊙	
	Kerosene	⊙	⊙	⊙	⊙	⊙	⊙	⊙	⊙	○	⊙	
	Naphtha	⊙	⊙	○	⊙	×	⊙	○	⊙	△	⊙	
Others	Nitrate	⊙	⊙	△	⊙		○	○	⊙	○	×	
	Hydro-carbon fuel	⊙	⊙	⊙	⊙	○	⊙	⊙	⊙	○	⊙	
	Fluorine gas	⊙	⊙	△	⊙		×	△	×	×	△	
	Molten metallic sodium	×	×	×			×					
	CFC (Freon) 134a	⊙	⊙	⊙	⊙		⊙	⊙	⊙	○	×	
	Liquid oxygen	⊙	⊙	○	⊙	⊙	⊙	○	⊙		○	
	Carbon dioxide	⊙	⊙	⊙	⊙	⊙	⊙	⊙	⊙	○	○	
Nitrogen dioxide	⊙	⊙	△	⊙	⊙	⊙	○				⊙	

Description of symbols: ⊙ : Excellent, ○ : Normal × : Incompatible * Under high temperature and pressure

The above shown chemical resistance is the resistance of the base resin only, and characteristics of each grade may differ depending on its filler.

It is important to know the required specifications, such as operating temperature, load, sliding velocity, PV value, mating material, torque, tolerances, type of motion and expected life, when designing with NTN Bearee.

6-1 Selection of bearing material (PV value)

When selecting the bearing material, examine the operating temperature, mating material, lubrication condition and so forth, along with the allowable pressure and sliding velocity.

PV value, the product of pressure “ P ” and sliding velocity “ V ”, is often used as the criteria to determine if the operating condition is allowable for the sliding material or not.

Each sliding material has its own allowable PV value; however, it also has an independent allowable value for pressure and velocity. Therefore, the allowable range is shown in **Figure 18**.

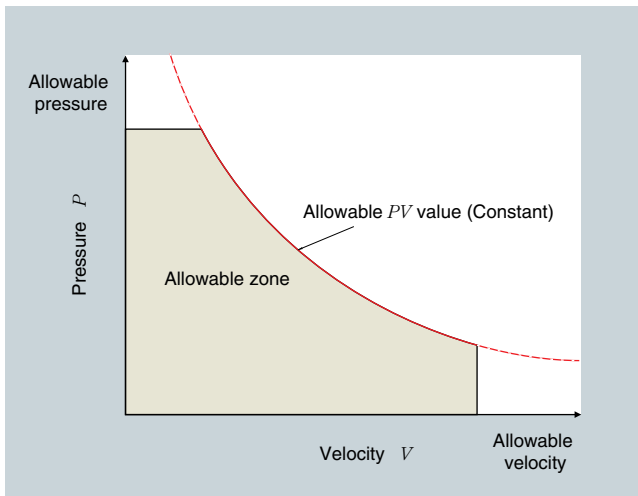

Figure 18 Allowable PV value

$$PV \leq \text{Allowable } PV \text{ value}$$

$$P \leq \text{Allowable } P$$

$$V \leq \text{Allowable } V$$

Pressure “ P ” and sliding velocity “ V ” is given by following formula.

$$P = Fr / d \cdot l$$

$$V = \pi \cdot d \cdot n \times 10^{-3}$$

P : pressure MPa

Fr : Radial load N

d : Shaft diameter mm

l : Length of bearing mm

V : Sliding velocity m / min

n : Shaft rotation rpm

6-2 Estimation of wear

The life of an NTN Engineering Plastics bearing is defined by the wear of sliding surface, as with an ordinary plain bearing.

The amount of wear varies with operating conditions such as sliding velocity, pressure, type of motion, surface roughness of mating material and operating temperature. Generally, the estimation of wear is given by the following formula.

$$R = K \cdot P \cdot V \cdot T$$

where

R : The amount of wear mm

K : Wear factor mm·min / MPa·m·h

P : pressure MPa

V : Sliding velocity m / min

T : Time h

Surface roughness of the mating material influences the wear of the NTN Engineering Plastics bearing; therefore, finish the surface to 0.1 to 0.8a. Moreover, NTN recommends the hardness of shaft to be HRC 22 or higher since it is possible to reduce the wear when the shaft is harder.

<Example>

Determine the amount of wear of R-AR1515 sleeve bearing made of BEAREE FL 3000 for the following operating condition.

<Specification>

Shaft diameter d : 15mm

Bearing load Fr : 300N

Shaft rotation n : 300rpm

Temperature : Room temperature

Service hours : 1000 hours

Lubrication : None

Pressure P (MPa) = $Fr / d \cdot l = 300 / 15 \times 15 \doteq 1.33$ MPa

Sliding velocity V (m/min) = $\pi \cdot d \cdot n = 3.14 \times 15 \times 300 / 1000 \doteq 14.1$ m/min

Wear factor at room temperature is given by page 10

$K = 1.0 \times 10^{-7} \text{ mm}^3 / \text{N} \cdot \text{m}$

$PV = 1.33 \times 14.1 \doteq 18.8$ MPa·m/min

$T = 1000\text{h} = 60\,000$ min

Therefore the amount of wear $R = K \cdot P \cdot V \cdot T$ is;

$R = 1.0 \times 10^{-7} \times 18.8 \times 60\,000 = 0.113$

The wear after 1000 hours of service is 0.113 mm.

6-3 Fits and clearance

Plain bearings are usually pressed into a housing. The minimum clearance for operation varies by the size of shaft though it can be as small as 0.025mm. When the operating temperature varies widely, the thermal expansion of bearing material should be taken into consideration. Increase the clearance by the amount of thermal expansion, with decreases the operating clearance.

It is also possible to finish the bore of mounted bearing by turning or reaming when accurate operation with small clearance is required. Although recommended shaft and bore diameters and mounted clearance are listed in the tables of standard series of NTN Engineering Plastics

Sliding Bearings, the mounted clearance may increase for soft material housings such as aluminum and plastics, or thin wall housing. Also, it is recommended to fix the bearing with a knock-pin, key, or bonding since the interference fit might be lost when the bearing is used under low temperature.

● **Calculation of bearing clearance (Except M-Liner bearing)**

The calculation step for “Standard temperature” , “Above 25°C” and “Below 20°C” is different. The step chart is shown below.

Calculation Step of Clearance for BEAREE Plain Bearing

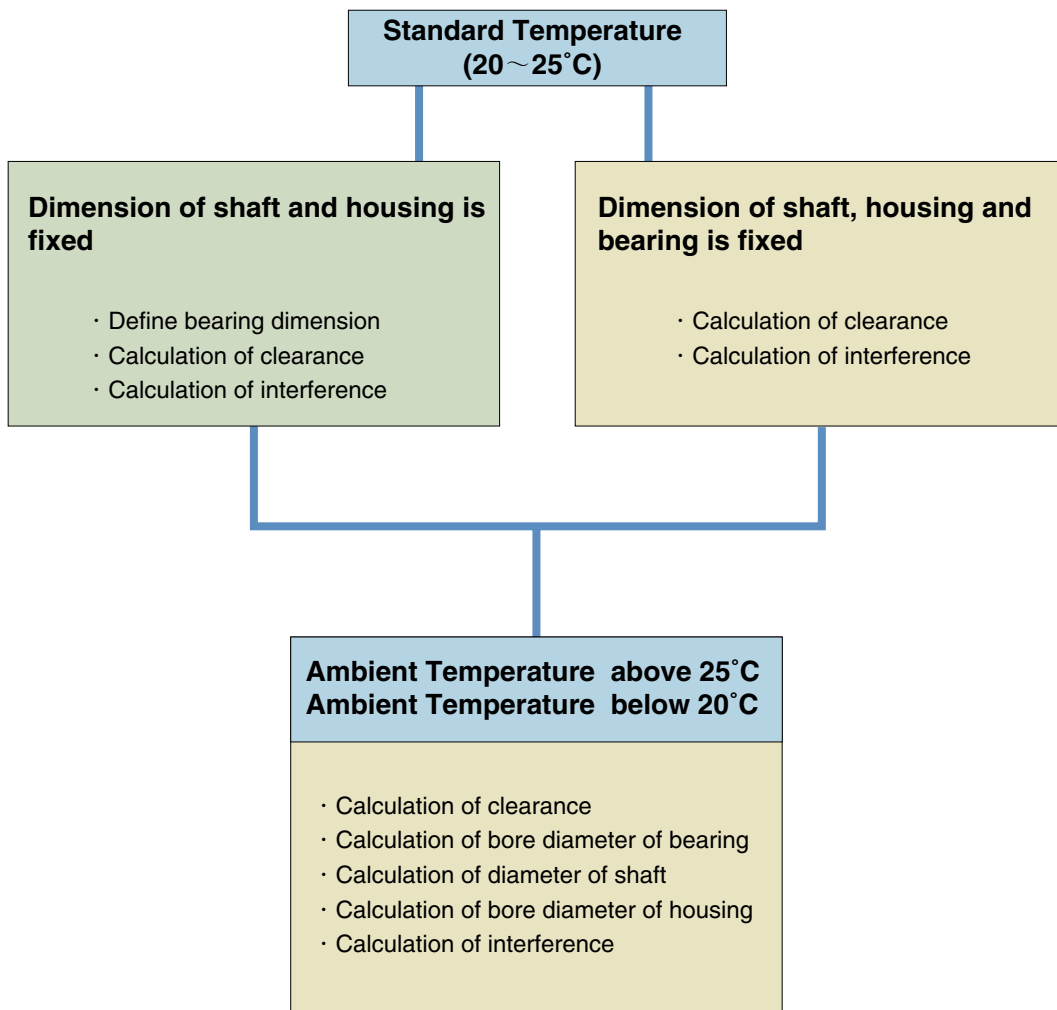

Note: Usually, the calculation for standard temperature is applicable to the ambient temperature range of 15 ~ 50°C

1. Calculation of clearance for standard temperature (25°C)

1) Interference

$$\text{Maximum: } F_H = D_H - H_L$$

$$\text{Minimum: } F_L = D_L - H_H$$

2) Reduction of bearing bore dimension due to interference fit

$$\text{Maximum: } E_{\max} = \lambda \cdot F_H \quad (\lambda = 1.0)$$

$$\text{Minimum: } E_{\min} = \lambda \cdot F_L \quad (\lambda = 1.0)$$

3) Bore dimension of bearing at standard temperature when mounted

$$\text{Maximum: } d_{25H} = d_H - E_{\min}$$

$$\text{Minimum: } d_{25L} = d_L - E_{\max}$$

4) Mounted clearance at standard temperature

$$\text{Maximum: } C_{\max} = d_{25H} - S_L$$

$$\text{Minimum: } C_{\min} = d_{25L} - S_H$$

Where

- S_H : Maximum shaft diameter
- S_L : Minimum shaft diameter
- H_H : Maximum housing bore diameter
- H_L : Minimum housing bore diameter
- d_H : Maximum bore diameter of bearing
- d_L : Minimum bore diameter of bearing
- D_H : Maximum outer diameter of bearing
- d_L : Minimum outer diameter of bearing

NOTE

1. The minimum clearance for NTN Engineering Plastic bearing is required 2 ~ 7/1000 of shaft diameter to reduce heat generation when used with no lubrication.
2. Shrink ratio by fit interference usually is set as 100%

<Example>

Calculate the clearance of type AR sleeve bearing R-AR1010 made of BEAREE FL 3000.

Assume shaft and housing bore dimensions follow NTN recommendation.

Shaft : $\phi 10$, h6 ($\begin{smallmatrix} 0 \\ -0.009 \end{smallmatrix}$) therefore $S_H = 10$, $S_L = 9.991$
 Housing : $\phi 14$, M7 ($\begin{smallmatrix} 0 \\ -0.018 \end{smallmatrix}$) therefore $H_H = 14$, $H_L = 13.982$
 Bearing I.D. : $\phi 10$ ($\begin{smallmatrix} +0.24 \\ +0.19 \end{smallmatrix}$) therefore $d_H = 10.24$, $d_L = 10.19$
 Bearing O.D. : $\phi 14$ ($\begin{smallmatrix} +0.10 \\ +0.05 \end{smallmatrix}$) therefore $D_H = 14.10$, $D_L = 14.05$
 Maximum interference : $F_H = D_H - H_L = 14.10 - 13.982 = 0.118$
 Minimum interference : $F_L = D_L - H_H = 14.05 - 14.00 = 0.05$
 Reduction of bearing bore : $E_{\max} = F_H \times \lambda = 0.118 \times 1 = 0.118$
 $E_{\min} = F_L \times \lambda = 0.05 \times 1 = 0.05$

Bearing bore at 25°C when mounted

$$d_{25H} = d_H - E_{\min} = 10.24 - 0.05 = 10.19$$

$$d_{25L} = d_L - E_{\max} = 10.19 - 0.118 = 10.072$$

Mounted clearance at 25°C:

$$C_{\max} = d_{25H} - S_L = 10.19 - 9.991 = 0.199 \div 0.2$$

$$C_{\min} = d_{25L} - S_H = 10.072 - 10 = 0.072 \div 0.07$$

2. Calculation of clearance for high temperature (T_H °C)

1) Housing bore dimension

$$\text{Maximum: } HH_H = H_H \{1 + \alpha_1 (T_H - 25)\}$$

$$\text{Minimum: } HH_L = H_L \{1 + \alpha_1 (T_H - 25)\}$$

2) Shaft diameter

$$\text{Maximum: } SH_H = S_H \{1 + \alpha_2 (T_H - 25)\}$$

$$\text{Minimum: } SH_L = S_L \{1 + \alpha_2 (T_H - 25)\}$$

3) Clearance during operation

Maximum:

$$CH_{\max} = \sqrt{(H_H)^2 \{1 + \alpha_1 (T_H - 25)\}^2 - (H_L)^2 - (d_{25H})^2 \{1 + \alpha_3 (T_H - 25)\}^2} - S_L \{1 + \alpha_2 (T_H - 25)\}$$

Minimum:

$$CH_{\min} = \sqrt{(H_L)^2 \{1 + \alpha_1 (T_H - 25)\}^2 - (H_L)^2 - (d_{25L})^2 \{1 + \alpha_3 (T_H - 25)\}^2} - S_H \{1 + \alpha_2 (T_H - 25)\}$$

Where

- α_1 : Coefficient of linear expansion of housing for T_H °C
- α_2 : Coefficient of linear expansion of shaft for T_H °C
- α_3 : Coefficient of linear expansion of bearing for T_H °C

*Reference Coefficient of linear expansion of various materials ($\times 10^{-5}/^\circ\text{C}$)

Material	α_1, α_2
Mild steel	1.1
Aluminum	2.3
Stainless steel	1.73

3. Calculation of clearance for low temperature (T_L °C)

1) Housing bore dimension

$$\text{Maximum: } HL_H = H_H \{1 + \alpha_{11}(T_L - 25)\}$$

$$\text{Minimum: } HL_L = H_L \{1 + \alpha_{11}(T_L - 25)\}$$

2) Shaft diameter

$$\text{Maximum: } SL_H = S_H \{1 + \alpha_{22}(T_L - 25)\}$$

$$\text{Minimum: } SL_L = S_L \{1 + \alpha_{22}(T_L - 25)\}$$

3) Clearance during operation

Maximum:

$$CL_{\max} = \sqrt{(H_H)^2 \{1 + \alpha_{11}(T_L - 25)\}^2 - \{(H_H)^2 - (d_{25H})^2\} \{1 + \alpha_{33}(T_L - 25)\}^2 - S_L \{1 + \alpha_{22}(T_L - 25)\}^2}$$

Minimum:

$$CL_{\min} = \sqrt{(H_L)^2 \{1 + \alpha_{11}(T_L - 25)\}^2 - \{(H_L)^2 - (d_{25L})^2\} \{1 + \alpha_{33}(T_L - 25)\}^2 - S_H \{1 + \alpha_{22}(T_L - 25)\}^2}$$

Where

α_{11} : Coefficient of linear expansion of housing for T_L °C

α_{22} : Coefficient of linear expansion of shaft for T_L °C

α_{33} : Coefficient of linear expansion of bearing for T_L °C

6-4 Handling

(a) Assembling method

Avoid hammering when pressing the bearing into the housing.

Use press machine with press arbor shown in **Figure 19** after centering bearing; and be sure that the housing chamfer is adequately large.

Use a knock pin or key to prevent rotation of the bearing, or use an adhesive to fasten the bearing for low temperature application, because the fitting might be loosened.

Remarks) Large-sized plastic bearings can be installed easily by cooling the bearing with dry ice.

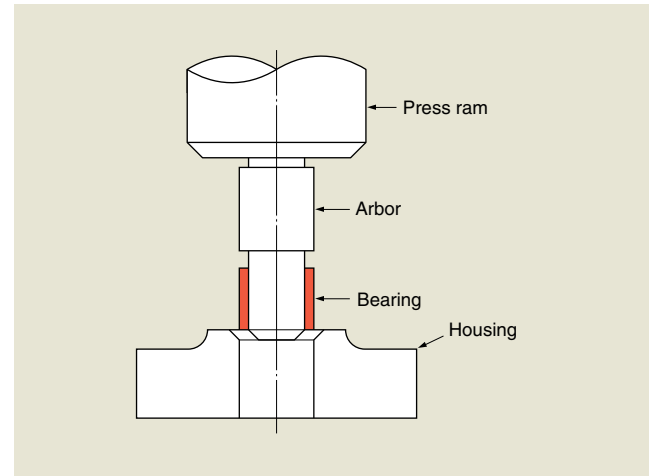
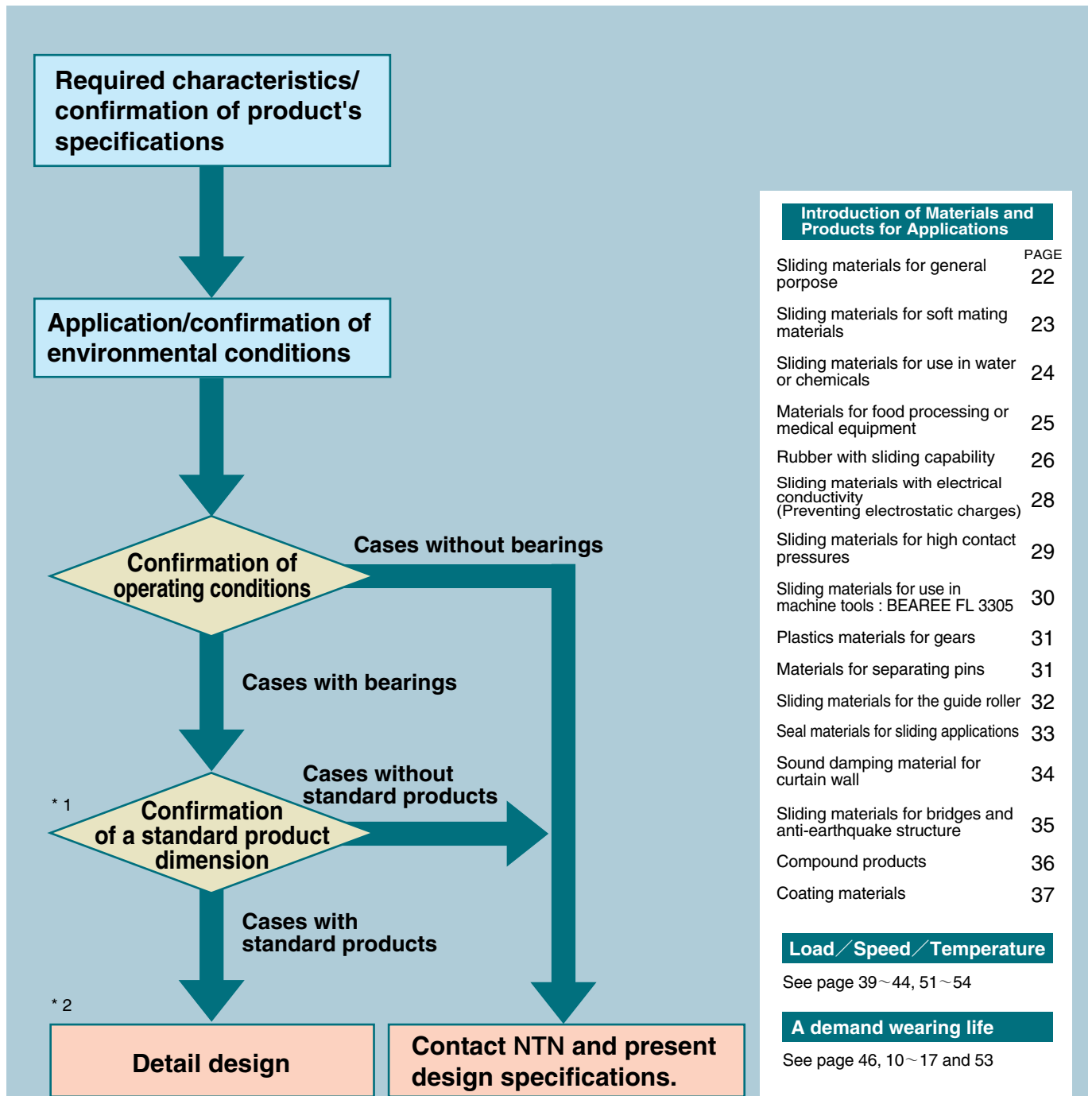

Figure 19 Assembling method

(b) Notice for handling

- (1) BEAREE FL could be deformed or scratched by a shock load, etc. and BEAREE PI could be cracked or chipped.
- (2) The surface roughness of mating material greatly affects bearing life.
NTN recommends surface roughness of 0.1 ~ 0.8a.
- (3) To fasten BEAREE bearing with adhesive, the bearing surface should be treated (etched) to make it bond-able. In that case, please advise us that, "Pre-etched one is required".
- (4) For bonding BEAREE bearing, an epoxy type adhesive is preferred.
- (5) Under some circumstances the operating temperature may loosen the clearance in the shaft and result in overheating, burning and seizing of the mechanism. Completely check the relation ship between fittings and clearances before application.

7-1 Design guideline of sliding performance parts

**Introduction of Materials and Products for Applications**

	PAGE
Sliding materials for general purpose	22
Sliding materials for soft mating materials	23
Sliding materials for use in water or chemicals	24
Materials for food processing or medical equipment	25
Rubber with sliding capability	26
Sliding materials with electrical conductivity (Preventing electrostatic charges)	28
Sliding materials for high contact pressures	29
Sliding materials for use in machine tools : BEAREE FL 3305	30
Plastics materials for gears	31
Materials for separating pins	31
Sliding materials for the guide roller	32
Seal materials for sliding applications	33
Sound damping material for curtain wall	34
Sliding materials for bridges and anti-earthquake structure	35
Compound products	36
Coating materials	37

Load/Speed/Temperature

See page 39~44, 51~54

A demand wearing life

See page 46, 10~17 and 53

* 1) Even for selecting a standard product, determine if the materials are suitable for use. Further, if the proper dimensions can not be found, design after selecting materials.

* 2) In the case of using the standard product, check the fittings and clearance according to the calculation on pages 47 to 49.

Remarks: If the application is for bearings and seal rings, use the "check list of conditions for use".

7-2 Temperature and allowable face pressure

The allowable face pressure of plastic sliding bearings depends on the base resin materials, it decrease when the temperature rises.

Table 22 shows the guideline.

Table 22 Temperature and the allowable face pressure of bearings

Allowable face pressure P MPa	Ambient temperature $^{\circ}\text{C}$		BEAREE FL3000 (PTFE)	BEAREE AS5000 (PPS)	BEAREE PI 5001 (PI)	BEAREE UH3000 (PE)	BEAREE PK5300 (PEEK)	BEAREE NY5000 (PA)	BEAREE DM5030 (POM)	BEAREE FL7075 (Coating)
	Over	Below								
	—	20	7	20	50	5	35	15	10	50
	20	60	6	20	50	2	35	10	7	50
	60	100	5	15	50	0.5	30	5	3	40
	100	140	4	10	40	—	25	1	—	30
	140	180	3	10	30	—	20	—	—	20
	180	220	1	7	20	—	15	—	—	10
	220	260	0.5	—	10	—	10	—	—	—
Allowable sliding velocity : \bar{V} m/min			200	200	200	30	150	30	50	50
Allowable pressure $P\bar{V}$ MPa · m/min			60	60	200	10	80	10	20	40

Allowable face pressure: Means the guideline for bearings.

Allowable sliding velocity, allowable $P\bar{V}$ value: Means the allowable value at room temperature.

7-3 Friction coefficient

The friction coefficient of plastic sliding bearings can vary widely in application conditions. **Table 23** shows the friction coefficients and test conditions for typical material grades of NTN Engineering Plastics.

Table 23 Friction coefficient of NTN Engineering Plastics materials

Materials	Test condition						Friction coefficient
	Test type	Mating material	Face pressure MPa	Sliding velocity m/min.	Lubrication	Ambient temperature °C	
BEAREE FL3000	Thrust	SUJ2	1.0	10.0	None	Room temperature	0.13
BEAREE FL3030	Thrust	SUS304	1.96	36.0	None	Room temperature	0.18
BEAREE PI 5001	Thrust	SUJ2	1.0	10.0	None	Room temperature	0.3
	Thrust	SUJ2	0.5	128.0	None	Room temperature	0.1
BEAREE UH5041	Thrust	SUJ2	1.0	10.0	None	Room temperature	0.12
BEAREE AS5053	Thrust	A5056	0.25	3.4	None	165	0.13
	Thrust	A5056	0.35	2.8	None	200	0.09
BEAREE PK5900	Thrust	SUS304	1.0	10.0	None	Room temperature	0.28
BEAREE NY5000	Thrust	SUJ2	0.3	32.0	None	Room temperature	0.21
BEAREE DM5030	Thrust	SUJ2	1.0	10.0	None	Room temperature	0.21
	Thrust	A5056	1.0	10.0	None	Room temperature	0.13
BEAREE ER3000	Thrust	SUJ2	0.3	1.0	None	Room temperature	0.28
	Thrust	SUS304	0.3	1.0	None	Room temperature	0.22
BEAREE FL7075	Thrust	A5056	0.22	2.4	None	Room temperature	0.13

7-4 Specific wear rate

The specific wear rate (wear factor) of plastic bearings can vary widely in application conditions. **Table 24** shows the specific wear rate and test conditions for typical material grades of NTN Engineering Plastics.

Table 24 Specific wear rate of NTN Engineering Plastics materials

Materials	Test condition						Specific wear rate × 10 ⁻⁷ mm ³ /N·m
	Test type	Mating material	Face pressure MPa	Sliding velocity m/min.	Lubrication	Ambient temperature °C	
BEAREE FL3000	Thrust	SUJ2	0.25	128.0	None	Room temperature	1.0
BEAREE FL3030	Thrust	SUS304	1.96	36.0	None	Room temperature	1.6
BEAREE PI 5001	Thrust	SUJ2	1.95	128.0	None	Room temperature	6.23
	Thrust	SUJ2	0.2	128.0	None	Room temperature	1.0
BEAREE UH5041	Thrust	SUJ2	0.3	32.0	None	Room temperature	0.3
BEAREE AS5053	Radial	A5056	0.25	3.4	None	165	13.0
	Radial	A5056	0.35	2.8	None	200	17.0
BEAREE PK5900	Thrust	SUS304	0.5	100.0	None	Room temperature	6.2
BEAREE NY5000	Radial	S45C	0.19	70.0	None	Room temperature	8.3
BEAREE DM5030	Thrust	SUJ2	0.3	32.0	None	Room temperature	1.5
	Thrust	A5056	0.3	32.0	None	Room temperature	5.0
BEAREE ER3000	Thrust	SUJ2	0.23	128.0	None	Room temperature	3.3
	Thrust	A2017	0.23	128.0	None	Room temperature	2.9
BEAREE FL7075	Thrust	SUS304	0.5	30.0	None	Room temperature	10.0

7-5 Thermal expansion coefficient

Table 25 shows the linear expansion coefficient of BEAREE FL. PTFE has a conversion point at 23°C, and its volume changes drastically at this point. Therefore, the dimensions measurement should be performed at 25°C. Also, since the expansion rate is different along the longitudinal (M.D.) and lateral (C.D.) direction regarding the molding direction, more caution is requested to determine the clearance.

Table 25 Linear expansion coefficient of BEAREE(FL) ($\times 10^{-5}/^{\circ}\text{C}$)

Range of temperature change °C	BEAREE FL3000		BEAREE FL3030		BEAREE FL3700		PTFE
	C.D.	M.D.	C.D.	M.D.	C.D.	M.D.	
-50~+ 20	6.7	9.6	9.2	9.2			13.5
-18~+ 20	8.2	12.6	9.2	9.2	9.0	7.9	16.2
+20~+ 25	22.2	36.8	19.1	29.8	24.6	33.5	50.2
+25~+100	8.0	10.1	9.0	9.8	7.2	8.5	12.4
+25~+150	8.3	10.7	9.0	9.8	7.7	9.9	13.5
+25~+200	9.3	11.7	10.4	11.2	8.5	10.6	15.1
+25~+260	11.0	13.6	11.1	11.8	9.7	13.5	18.0

Remarks M.D.: Longitudinal direction (Compression molding, the axial direction of continuously molded rod or pipe.)

C.D.: Lateral direction (Right angled direction to the axial direction mentioned above.)

7-6 Test data

Applications of plastic bearings are rapidly increasing. The latest test data are shown as follows.

BEAREE FL3000

Test condition (Friction test)

- Test unit : Thrust type friction and wear test unit.
- Mating material : Bearing steel(SUJ2). Rotation sample piece
- Face pressure : 0.5-10 MPa
- Sliding velocity : 10 m/min.
- Lubrication : None

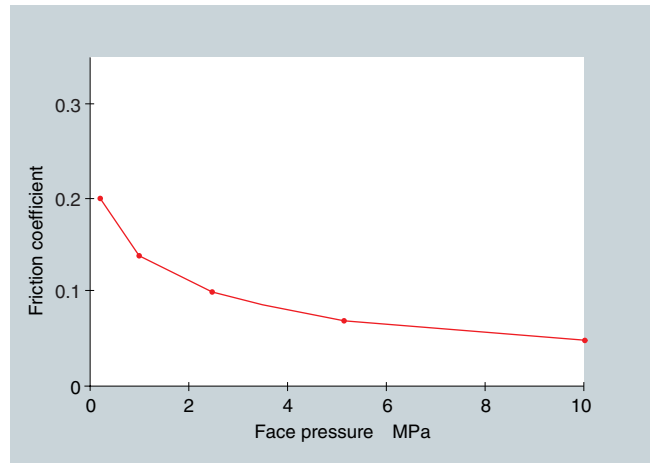

Fig.20 Friction coefficient versus face pressure

BEAREE FL3000

Test condition (Friction test)

- Test unit : Thrust type friction and wear test unit.
- Mating material : Bearing steel(SUJ2). Rotation sample piece
- Face pressure : 1 MPa
- Sliding velocity : ~100 m/min.
- Lubrication : None

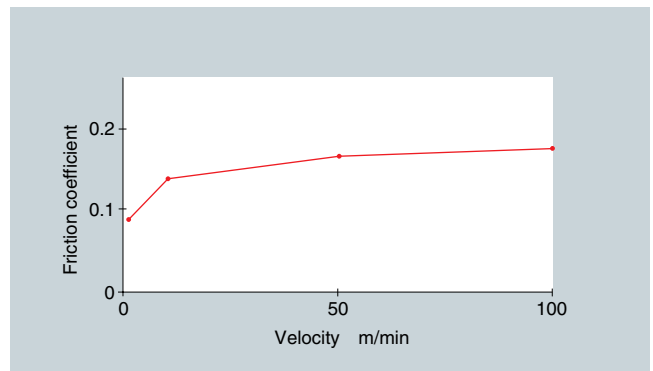

Fig.21 Friction coefficient versus sliding velocity

BEAREE FL3000

Test condition (Wear test)

- Test unit : Thrust type friction and wear test unit.
- Mating material : Bearing steel(SUJ2). Rotation sample piece
- Face pressure : 0.08-0.8 MPa
- Sliding velocity : 128 m/min.
- Lubrication : None
- Test time : 100 hours

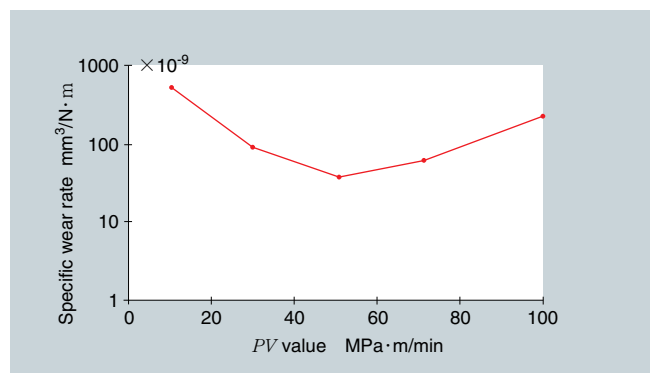

Fig.22 Specific wear rate versus PV value

BEAREE PI5001

Test condition (Friction test)

Test unit : Thrust type friction and wear test unit.
 Mating material : Bearing steel(SUJ2). Rotation sample piece
 Face pressure : 0.5, 0.8 MPa
 Sliding velocity : 128 m/min.
 Lubrication : None
 Ambient temperature: 100°C

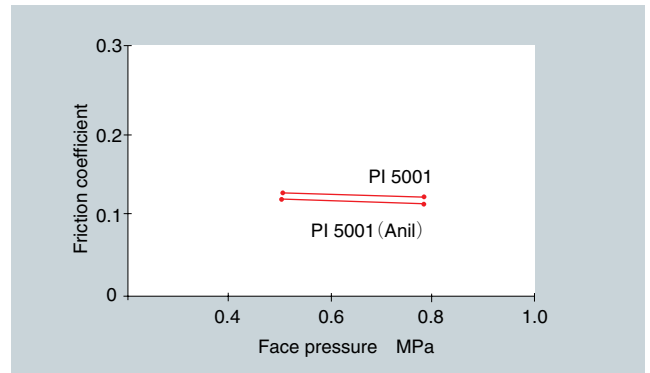

Fig.23 Friction coefficient versus face pressure

BEAREE PI5001

Test condition (Wear test)

Test unit : Thrust type friction and wear test unit.
 Mating material : Bearing steel(SUJ2). Rotation sample piece
 Face pressure : 0.2-2.0 MPa
 Sliding velocity : 128 m/min.
 Lubrication : None
 Ambient temperature: Room temperature

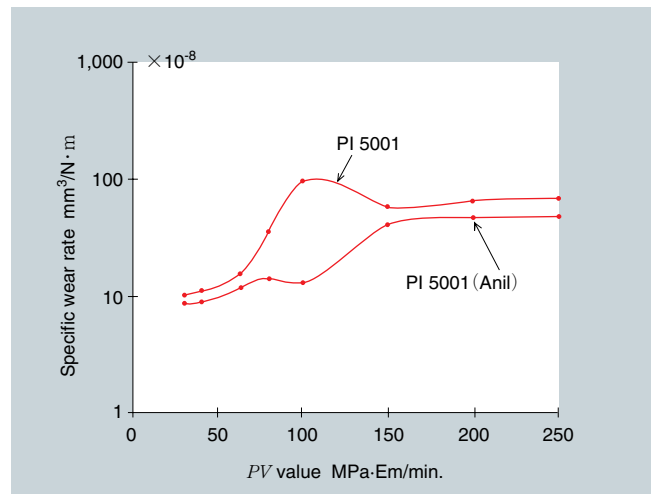

Fig.24 Specific wear rate versus PV value

BEAREE AS5053

Test condition (Wear test)

Test unit : Radial type friction and wear test unit.
 Mating material : A5056(3.2S, HV45)
 Face pressure : 0.35 MPa
 Sliding velocity : 2.8 m/min.
 Lubrication : None
 Ambient temperature: 200°C
 Test time : 50 hours
 Specific wear rate : 1.7x10⁻⁶ mm³/N·m

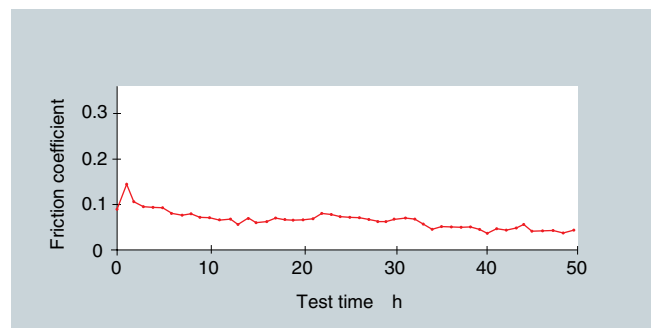

Fig.25 Friction coefficient during the wear test

BEAREE DM5030

Test condition (Friction test)

- Test unit : Thrust type friction and wear test unit.
- Mating material : Bearing steel(SUJ2). A5056
- Face pressure : 1 MPa
- Sliding velocity : 10 m/min.
- Lubrication : None
- Ambient temperature : Room temperature
- Test time : 60 minutes

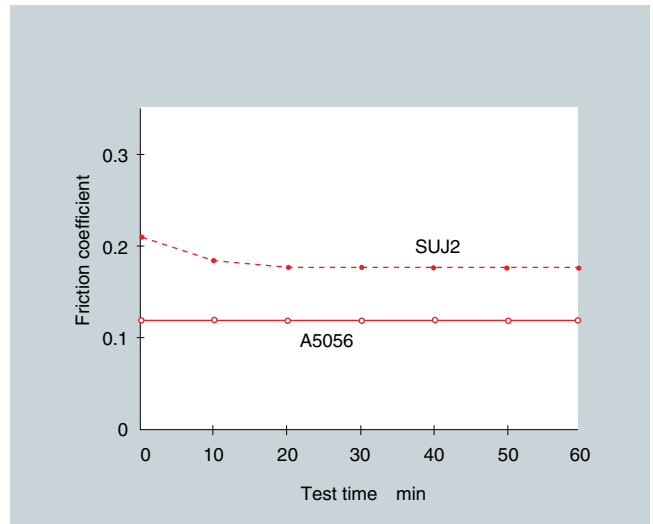

Fig.26 Friction coefficient versus running time

BEAREE ER3000

Test condition (Friction test)

- Test unit : Thrust type friction and wear test unit.
- Mating material : Bearing steel(SUJ2)
- Face pressure : 0.3 MPa
- Sliding velocity : 1.0 m/min.
- Lubrication : None
- Ambient temperature : Room temperature

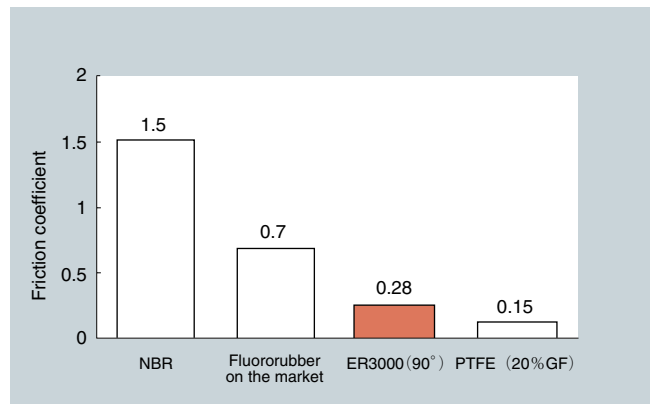

Fig.27 Friction coefficient comparison mating SUJ2

BEAREE FL7075 (Coating)

Test condition (Friction test)

- Test unit : Thrust type friction and wear test unit.
- Mating material : SUS304
- Face pressure : 0.01, 0.2 MPa
- Sliding velocity : 0.01-10 m/min.
- Lubrication : None
- Ambient temperature : Room temperature

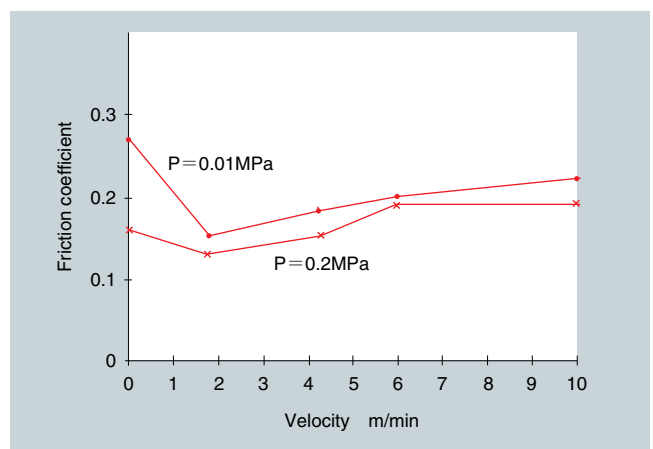
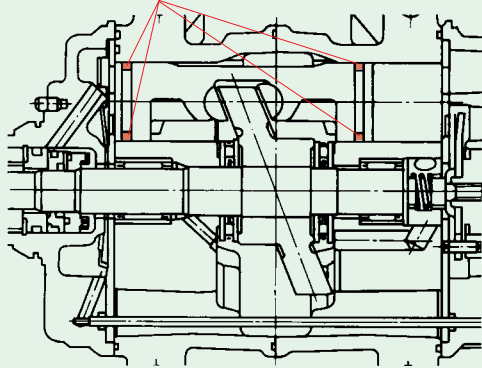
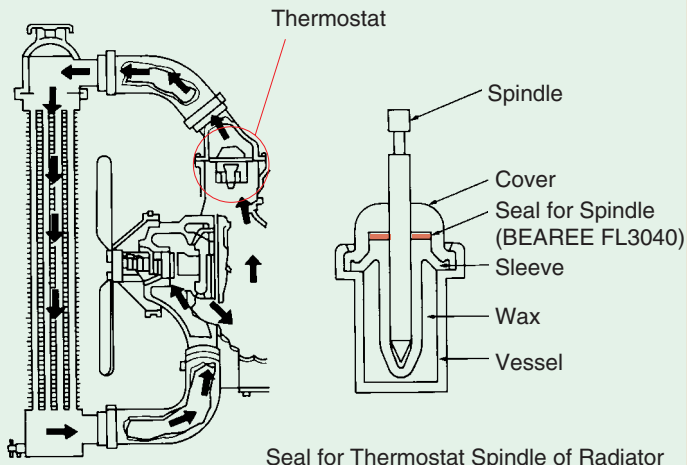
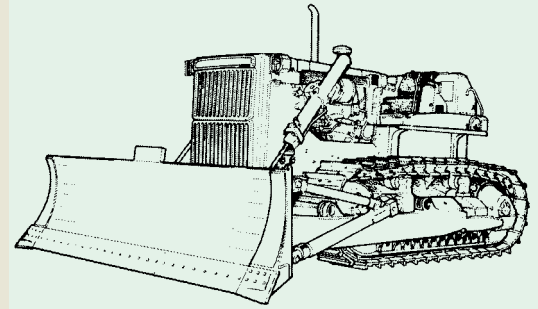

Fig.28 Friction coefficient versus sliding velocity

Piston Seal Ring
(BEAREE FL 3000, FL 3030)



Piston Seal Ring for Car Air Conditioner Compressor



Seal for Thermostat Spindle of Radiator

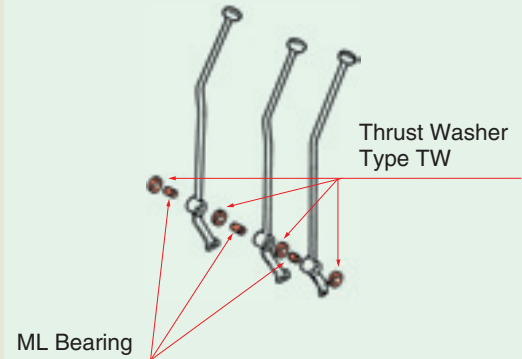

Control Lever for Construction Machine

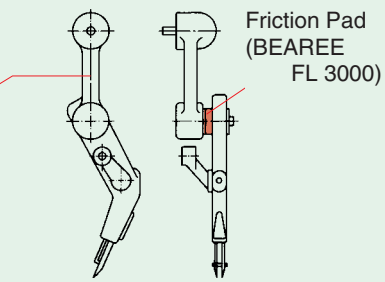
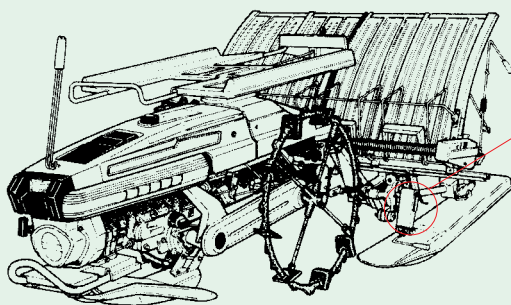

Hinge for Agricultural Machine

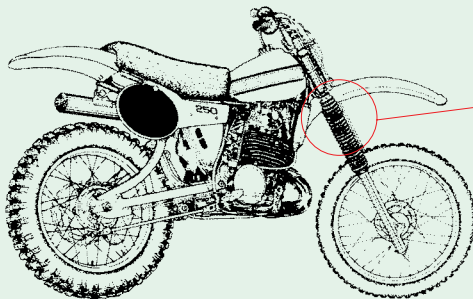

Piston Ring
(BEAREE FL 3030)

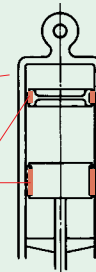

Front Fork for Motorcycle

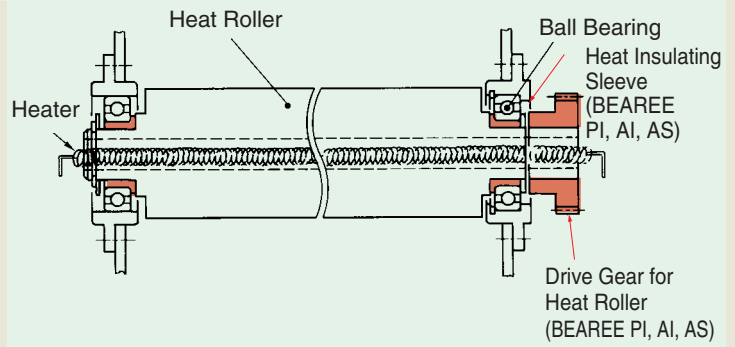
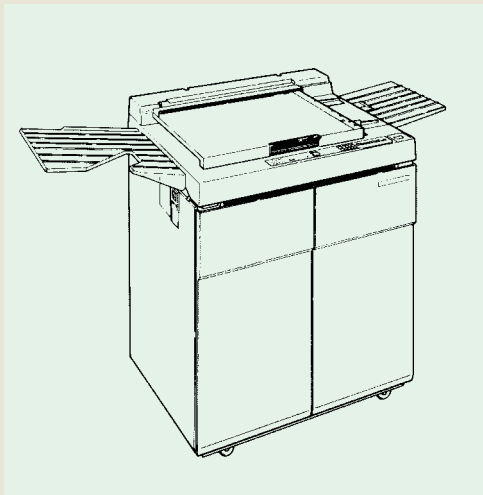
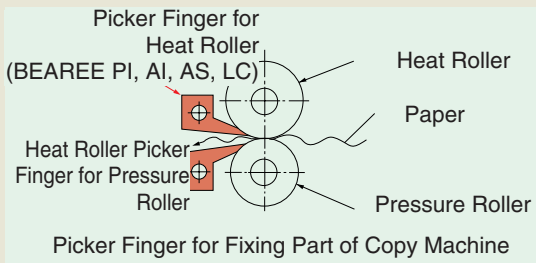

Heat Roller Drive Gear and Heat Insulating Sleeve for Copy Machine

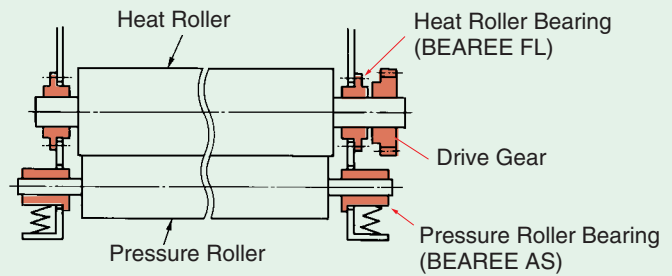

Heat Roller and Pressure Roller Bearing for Copy Machine

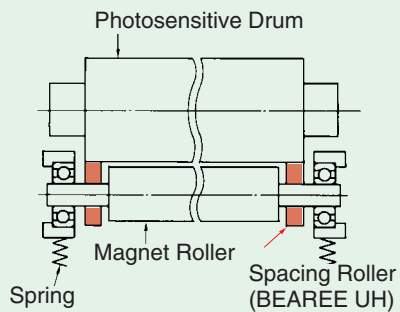

Spacing Roller for Developing Part of Copy Machine

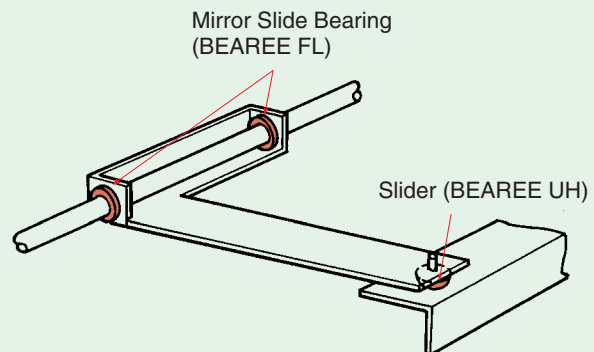

Mirror Slide Bearing and Slider for Optical Part of Copy Machine

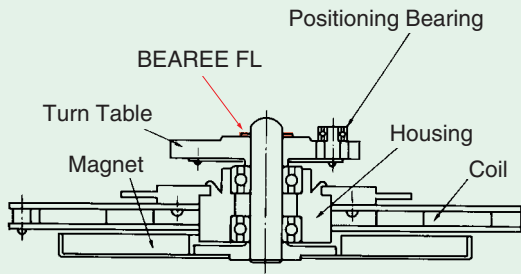

Turn Table for 3.5" FDD

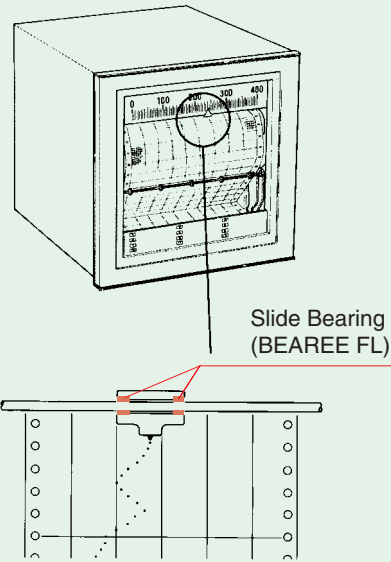

Sliding Part for Pen Recorder

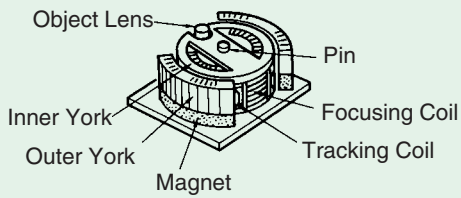

Pickup Focusing Unit for Optical Disk

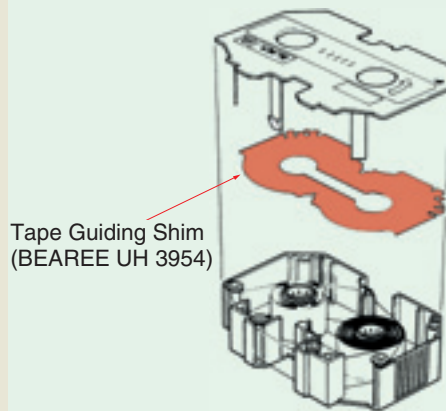
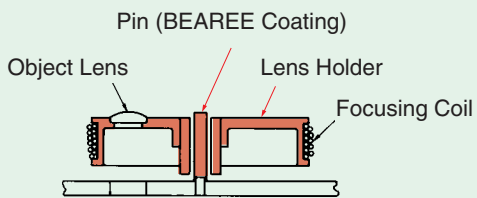

Ink Ribbon Cassette for Printer

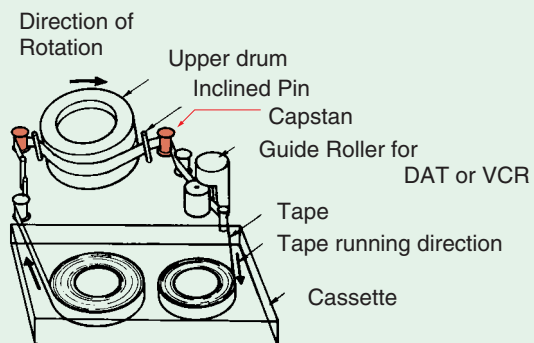

Guide Roller for DAT or VCR

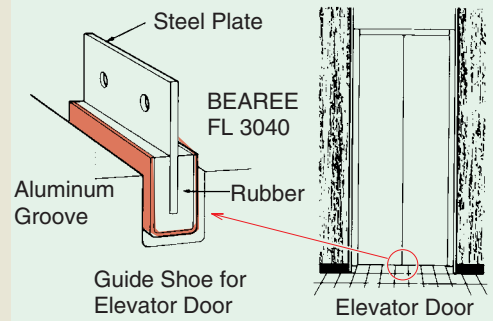
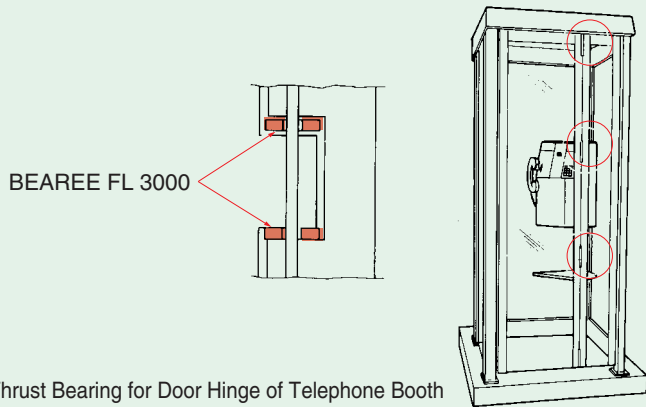
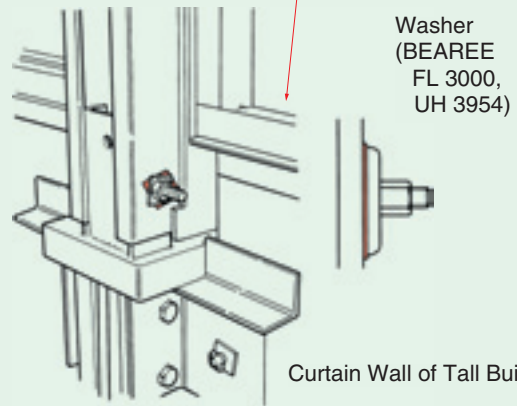
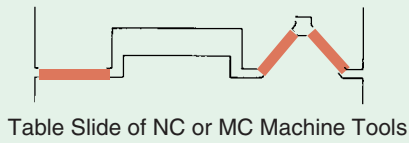
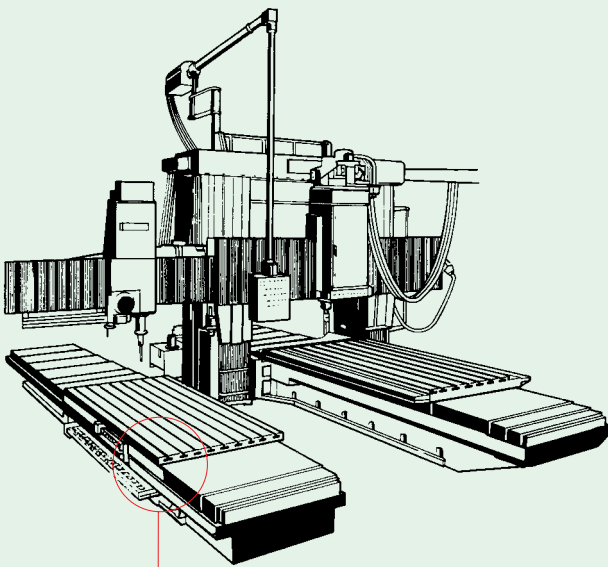
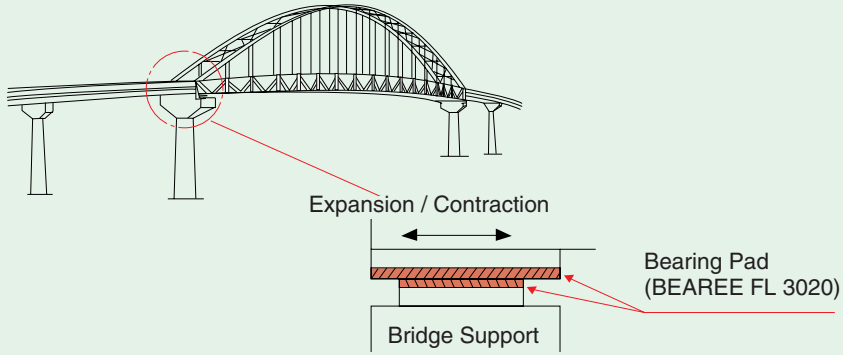

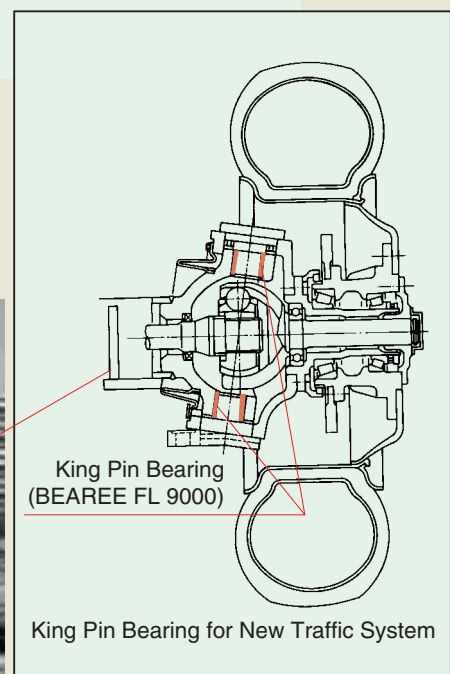
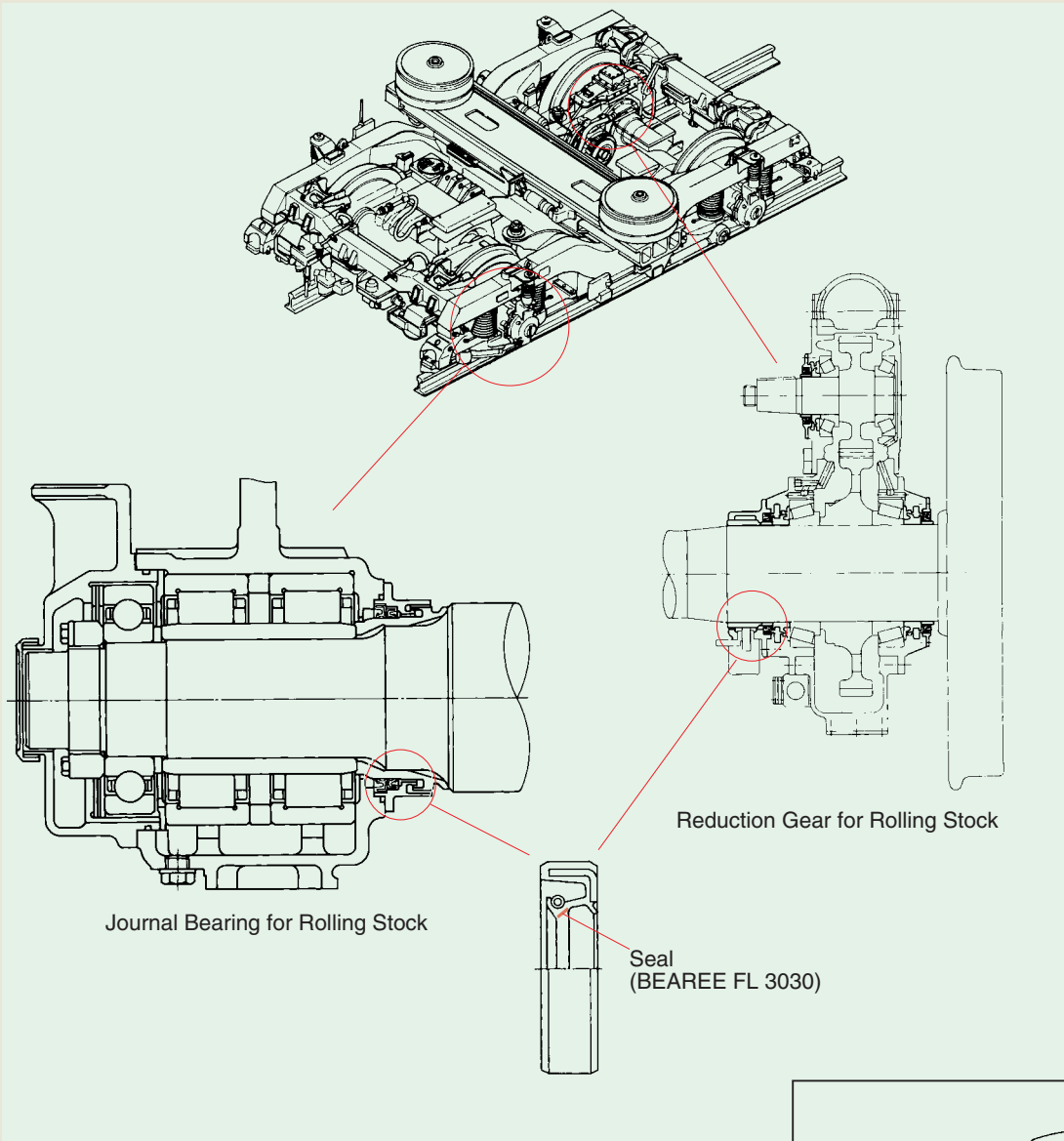

Company name/Division _____

Your name _____

Phone _____ Fax _____

NTN Engineering Plastics Application Inquiry

Items	Confirmation
1. Equipment	
2. Application	
3. Ambient temperature	Max. Min. °C
4. Ambient humidity	%
5. Environment	Air, Water, Sea Water
6. Type of load	Static, Dynamic, Shock, Vibration, Repetition Other()
7. Type of motion	Rotation, Rocking, Oscillation, Other()
8. Operating time	h/day cycle/min
9. Speed	rpm
10. Sliding velocity	m/min
11. Load	Axial, Radial, N {kgf}
12. Pressure(Seal ring)	MPa {kgf/cm ² }
13. Lubrication	
14. Shaft	Dimension :
	Material :
	Hardness :
	Roughness :
15. Housing	Dimension :
	Material :
	Hardness :
	Roughness :
16. Remarks	

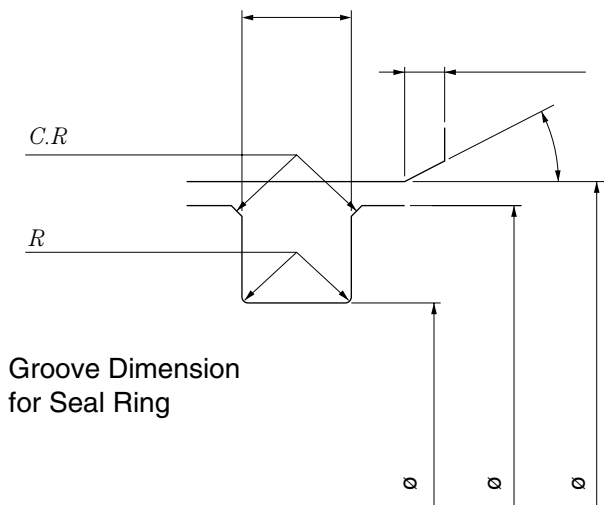

Groove Dimension for Seal Ring

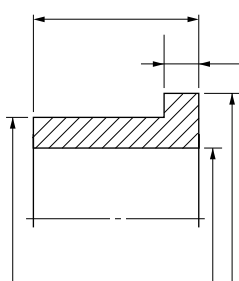

Bushing

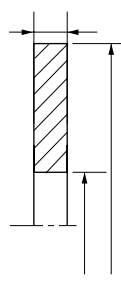

Thrust Washer