



**DODGE**<sup>®</sup>

2010  
**DODGE**<sup>®</sup> **MAGNAGEAR**

**GEARING**  
**ENGINEERING CATALOG**



**BALDOR**

# CONTENTS



## MagnaGear

---

Features & Benefits . . . . .	2
Specifications . . . . .	4
Nomenclature . . . . .	5
Easy Selection . . . . .	6
Selection/Dimensions . . . . .	16
Engineering/Technical . . . . .	73
Part Number Index . . . . .	INDEX-1

Features/Benefits

Specifications

Nomenclature

Easy Selection

Selection/Dimensions

# FEATURES/BENEFITS



## MagnaGear XTR

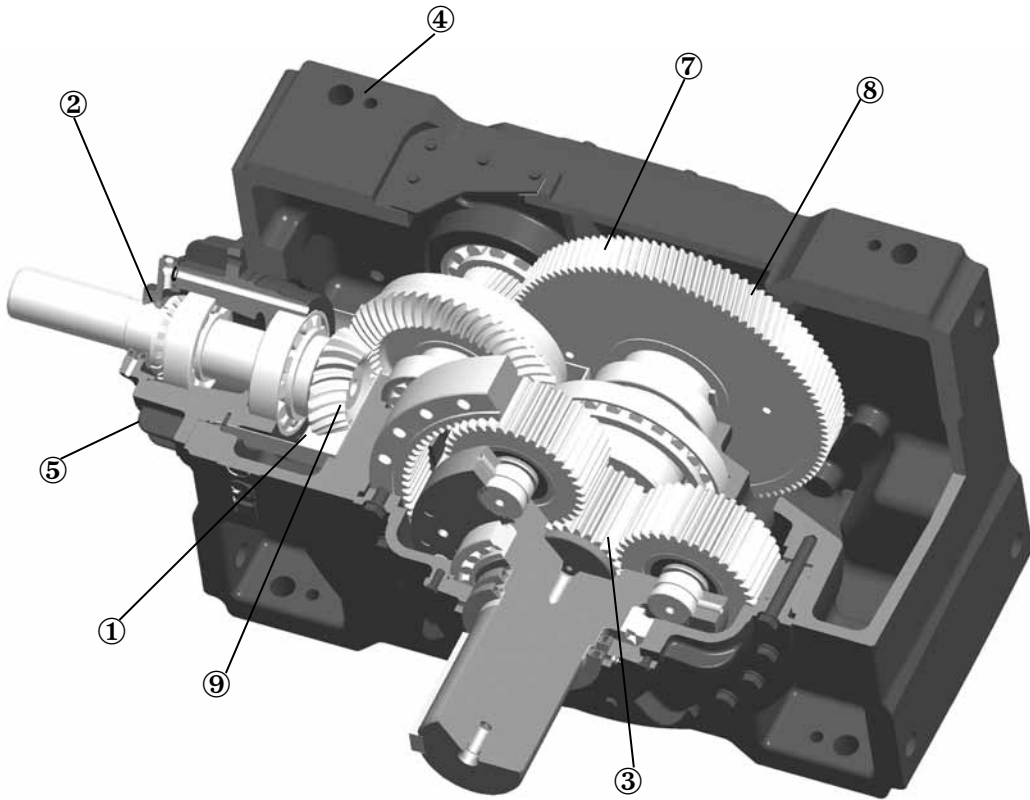

### 1. Longer-Life Bearings

Bearing designs meet or exceed AGMA standards, resulting in projected L-10 life over twice that of most competitors

### 2. Tandem Lip Seals

Working together, MagnaGear XTR reducer's standard HNBR lip seals minimize shaft wear, provide high temperature protection and twice the sealing power to contain lubricant and protect against contaminants

### 3. Power Dense Design

Heavy-duty power dense design gives you more power in less space and proven DODGE Planetary Gearing

### 4. Universal Housing

Rugged cast iron housing with multiple mounting pads allows a variety of mounting configurations and is reversible to minimize spares

5. Housing designed to increase heat dissipation

### 6. Oversized Inspection Covers

Oversized inspection covers on the MagnaGear XTR reducer housing allows easy accessibility

7. High precision hardened and ground gearing

8. Gear tooth geometry designed to maximize efficiency

9. Available in right angle or parallel shaft configurations

## MagnaGear XTR Design Elements and Proven Dodge Features

### MagnaGear XTR Advantages

- Maximum reliability
- Proven Dodge reducer technology
- Longer bearing life
- Premium seal arrangement
- Premium gearing designed with FEA (Finite Element Analysis) computer modeling
- Improved heat dissipation
- Capabilities exceeding 2,500 Hp
- Lower Total Cost of Ownership
- Easy maintenance

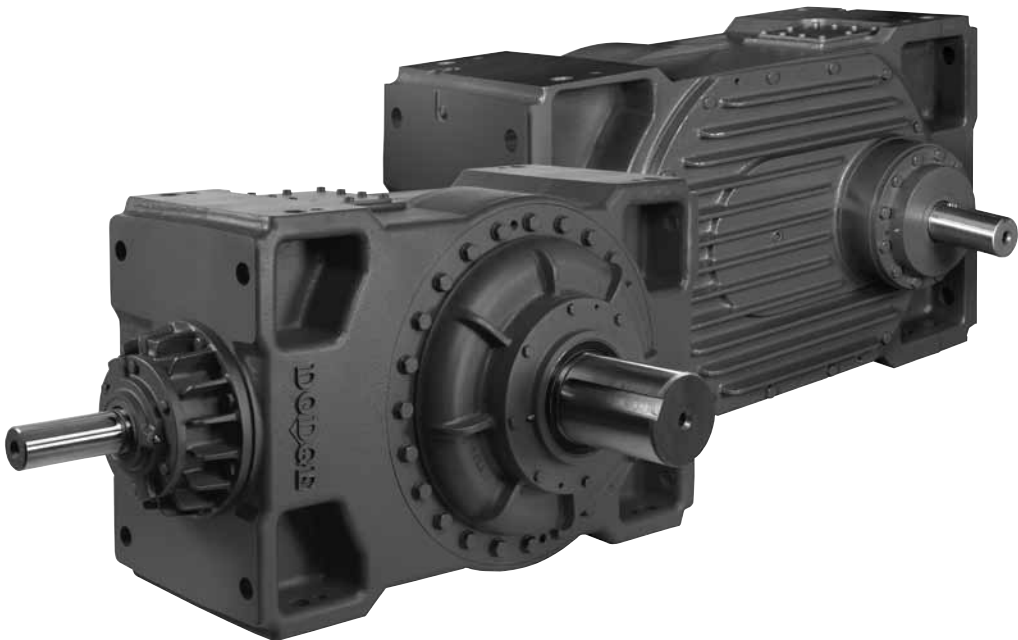

# SPECIFICATIONS



## GENERAL SPECIFICATIONS for DODGE MAGNAGEAR Speed Reducers to 920,000 in-lbs

MagnaGear speed reducers are a 2 or 3 stage reduction in a parallel or right angle shaft configuration. Gearing type is helical, bevel helical and planetary. Output shaft is solid or hollow with a twin taper bushing. Mounting configurations include foot or shaft mounting and standard mounting accessories include solid base, swing base and tunnel housing. Cooling systems include a shaft mounted fan, electric fan or external cooling system with a water to oil or air to oil heat exchanger.

### Gearing

MagnaGear sizes G100 through G390 utilize helical or bevel helical gearing. Sizes G525 through G920 utilize helical or bevel helical gearing with a planetary gear output.

Gear materials are a carburizing grade alloy steel which meets an AGMA Grade 2 standard. All gearing is case carburized to ensure a high surface durability and resilient tooth core for greater impact resistance and longer service life.

Bevel, helical, planet gears and sun pinion are ground after heat treating and carburizing to an AGMA Q11 minimum quality level. Gear quality is equivalent to DIN Grade 6 standard.

### Castings

MagnaGear housings are constructed of Class 30 gray iron. Housings are suitable for horizontal output shaft mounting on 4 sides. The same housings are used for parallel and right angle reducers.

Housings are a mono-block construction. MagnaGear sizes G525 and larger have oversized assembly covers for ease of maintenance. All housings include bolted end covers instead of bore plugs. Housings and assembly covers are precision matched to ensure proper gear alignment.

Housings include cast cooling fins for greater thermal horsepower capabilities.

Pipe fittings and plugs are NPT.

### Lubrication

Gearing is splash and dip lubricated. Bearings are lubricated by dip and by gravity feed.

Mineral based EP oils are the preferred lubricant, suitable for operating temperatures up to 200°F (93°C) as well as for low ambient temperatures down to 25°F (-4°C). For applications outside this temperature range, synthetic lubricants which are suitable for operating temperatures up to 212°F (100°C) as well

as for low ambient temperatures down to -15°F (-26°C) may be used. Recommended oil viscosity ISO grade is 220EP to 320EP, depending on output RPM and ambient temperature.

MagnaGear reducers are compatible with rust and oxidation inhibiting (R&O) and polyalpha olefin (PAO) lubricants.

Oil sampling ports are standard.

### Bearings

Bearings are spherical type on planetary gears, all others are tapered roller type.

Bearings ratings are based on a minimum unadjusted L-10 life of 5000 hours, providing a minimum 25,000 hour average life.

### Sealing

Input and output shaft seals are a tandem radial lip arrangement. Between the tandem seals is a grease purge cavity.

Seals are constructed of hydrogenated nitrile butadiene rubber (HNBR).

### Shafts

MagnaGear sizes G100 through G390 are available with a twin taper bushing hollow output shaft. The taper bushing is manufactured from ductile iron.

Shaft extensions are metric dimensions to conform to global standards.

### Backstops

Backstops are a centrifugal throw out, lift off design which eliminates sprag sliding and reduces wear. Backstops are integrally mounted on the input shaft of parallel MagnaGear reducers or on the intermediate shaft of right angle reducers.

Backstops are lubricated by the oil in the reducer and are EP and synthetic oil compatible.

## MAGNAGEAR

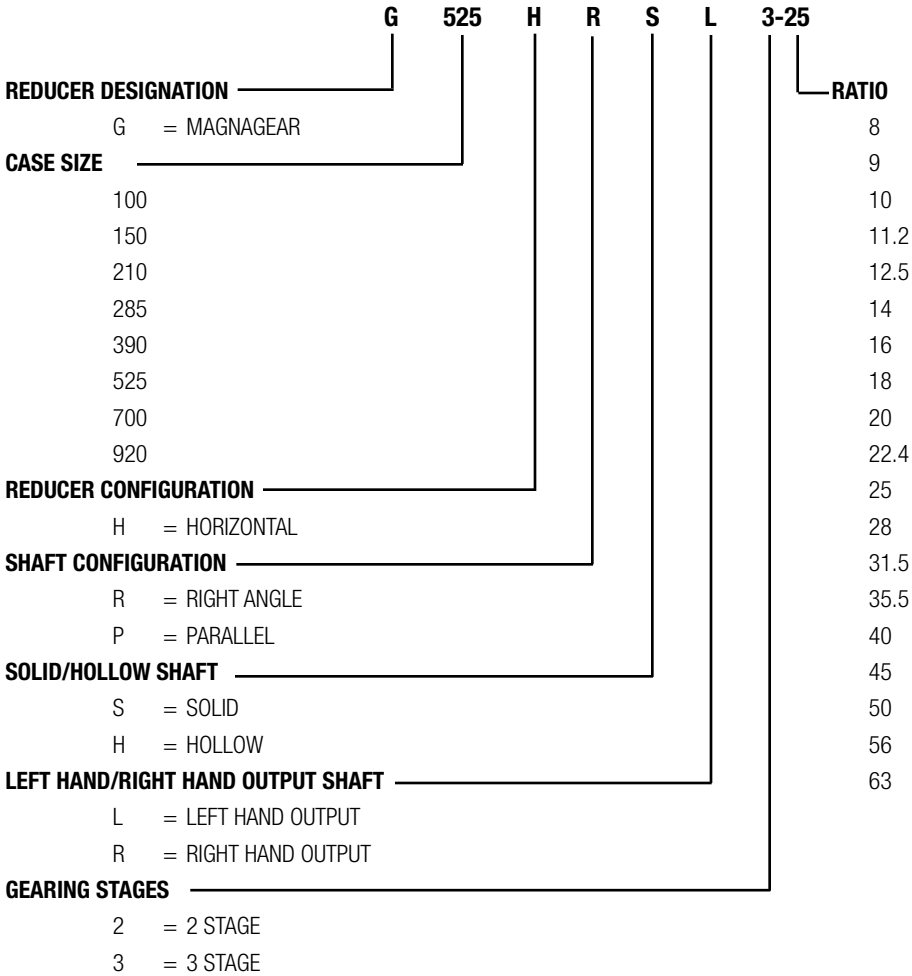

**NOMENCLATURE EXAMPLE: G525HRSL3-25**

# EASY SELECTION



## MagnaGear Reducer

### EASY SELECTION METHOD (for 1750 RPM motors)

#### When to Use Easy Selection

The MagnaGear Easy Selection tables are for electric motor selections up to 1400 Hp with input speeds of 1750 rpm using AGMA recommended service factors. For all other motor/prime mover input speeds and horse powers, use the Horsepower/Torque Selection Method on pages 74 through 90.

**NOTE:** If your application has unusual requirements (i.e., excessive shock or overloads, extreme ambient temperatures, non-standard motors or oversized equipment), refer to Horsepower/ Torque Selection Method.

#### How to Select

Step 1: Determine Service Factor – See Table 2 to determine service factor for applications under normal conditions. Note: When service factor exceeds 2.0, Horsepower/ Torque Selection Method must be used.

Step 2: Determine Unit Size – See Easy Selection tables on pages 10 through 15. Find the service factor table that is required for the application. Read the unit size under required horsepower and opposite the required low speed shaft RPM. Note: For applications where fan cooling is unacceptable, use easy selection table with an increased service factor.

Step 3: Check External Thrust and Overhung Load – Consult DODGE about external thrust loads and overhung loads.

Step 4: Check Dimensions – See specification/dimension section, pages 18 through 73 for dimensions, weights, drawings and part numbers.

Step 5: Select Accessories.

#### Example: Easy Selection Method

A 300 Hp 1750 RPM motor is used to drive a heavy duty belt conveyor at 80 rpm operating 16 hours per day. A parallel shaft reducer is required. The reducer is coupling connected at both the input and output shafts.

Step 1: Determine Service Factor – From Table 2, Service Factors, locate “Belt Conveyors - Heavy Duty not Uniformly Fed”. Select the Service Factor of 1.50 under the column headed 10+ hours/day of service.

Step 2: Determine Unit Size – Turn to the Easy Selection Table for Parallel Reducers with a 1.5 Service Factor (page 11). Find the column headed by 350 motor horsepower and read down to a 78 low speed shaft rpm. A MagnaGear G525 is the correct selection and the nominal ratio is 22.4:1.

Step 3: Check External Thrust and Overhung Load – Since the input and output shafts are coupling connected, thrust and overhung loads will not exist. Consult DODGE about external thrust loads and overhung loads.

Step 4: Check Dimensions – Refer to the dimensions for a Dodge MagnaGear size G525 reducer located on page 63. The part number for the reducer is **449722** and is found on page 61.

Step 5: Select Accessories – A mechanical cooling fan is required for this example. Refer to the accessory part numbers for a Dodge MagnaGear size G525 reducer located on page 62. The part number for a mechanical cooling fan kit is **453954**.

## MagnaGear

The service factors that follow are adapted from AGMA 6019-E89 Appendix A.

Applications which expose the gear drive to high starting torques, extreme repetitive shock, or where high energy loads must be absorbed as when stalling, require special consideration. Service factors for these special applications should be agreed upon by the user and DODGE since variations of the values in the table may be required.

The service factors in the table are based upon the use of an electric or hydraulic motor or the use of a steam or gas turbine as a prime mover. If the prime mover is a single or multi-cylinder engine, then the service factor must be adjusted in accordance with Table 1.

**Table 1: Conversion Table For Single Or Multi-Cylinder Engines To Find Equivalent Single Or Multi-Cylinder Application Factor Or Service Factor**

Steam and Gas Turbines, Hydraulic or Electric Motor	Single Cylinder Engines	Multi Cylinder Engines
1.00	1.50	1.25
1.25	1.75	1.50
1.50	2.00	1.75
1.75	2.25	2.00
2.00	2.50	2.25
2.25	2.75	2.50
2.50	3.00	2.75
2.75	3.25	3.00
3.00	3.50	3.25
3.50	4.00	3.75

**Table 2: Service Factors**

Application	Service		Application	Service		Application	Service	
	3-10 Hrs./Day	10+Hrs./Day		3-10 Hrs./Day	10+Hrs./Day		3-10 Hrs./Day	10+Hrs./Day
<b>AGITATORS</b>			Scale Hoppers -			Reciprocating:		
Pure Liquids	1.00	1.25	Frequent Starts	1.25	1.50	Multi-cylinder	1.50	1.75
Liquids & Solids	1.25	1.50	<b>BRICK PRESS (Clay Working)</b>	1.75	2.00	Single Cylinder	1.75	2.00
Liquids - Variable Density	1.25	1.50	<b>BRIQUETTE MACHINES (Clay Working)</b>	1.75	2.00	<b>CONCRETE MIXERS</b>		
<b>APRON CONVEYORS</b>			<b>BUCKET</b>			Continuous	1.25	1.50
Uniformly Loaded or Fed	1.00	1.25	Conveyors Uniform	1.00	1.25	Intermittent	1.25	1.50
Heavy Duty	1.25	1.50	Conveyors Heavy Duty	1.25	1.50	<b>CONVEYORS - Uniformly Loaded or Fed:</b>		
<b>APRON FEEDERS</b>	1.25	1.50	Elevators Cont.	1.00	1.25	Apron Assembly, Belt, Bucket, chain, Flight		
<b>ASSEMBLY CONVEYORS</b>			Elevators Uniform	1.00	1.25	Oven, Screw	1.00	1.25
Uniformly Loaded or Fed	1.00	1.25	Elevators Heavy Duty	1.25	1.50	<b>CONVEYORS - Heavy Duty</b>		
Heavy Duty	1.25	1.50	<b>CALENDERS</b>			Not Uniformly Fed:		
<b>BALL MILLS</b>	▲	▲	Rubber		1.50	Apron, Assembly, Belt, Bucket, Chain, Flight, Oven, Screw	1.25	1.50
<b>BARGE HAUL PULLERS</b>	1.25	1.50	Textile	1.25	1.50	<b>CONVEYORS-Severe Duty</b>		
<b>BARKING</b>			<b>CANE KNIVES</b>		1.50	Live Roll Reciprocating	†	†
Drums (coupling connected)		2.00	<b>CAN FILLING MACHINES</b>	1.00	1.25	Shaker	1.75	2.00
Mechanical		2.00	<b>CARD MACHINES (Textile)</b>	1.25	1.50	<b>COOKERS (Brewing &amp; Distilling), (Food)</b>	1.25	1.25
<b>BAR SCREENS (Sewage)</b>	1.25	1.25	<b>CAR DUMPERS</b>	1.75	2.00	<b>COOLING TOWER FANS</b>	†	†
<b>BATCHERS (Textile)</b>	1.25	1.50	<b>CAR PULLERS</b>	1.25	1.50	<b>CRANES</b>	†	†
<b>BELT CONVEYORS</b>			<b>CEMENT KILNS</b>	▲	▲	<b>CRUSHERS</b>		
Uniformly Loaded or Fed	1.00	1.25	<b>CENTRIFUGAL</b>			Ore or Stone	1.75	2.00
Heavy Duty	1.25	1.50	Blowers, compressors, Discharge Elevators, Fans or Pumps	1.00	1.25	Sugar		1.50
<b>BELT FEEDERS</b>	1.25	1.50	<b>CHAIN CONVEYORS</b>	1.00	1.25	<b>DEWATERING SCREENS</b>		
<b>BENDING ROLLS</b>			Uniformly Loaded or Fed	1.00	1.25	(Sewage)	1.50	1.50
(Machine)	1.25	1.50	Heavy Duty	1.25	1.50	<b>DISC FEEDERS</b>	1.00	1.25
<b>BLOWERS</b>			<b>CHEMICAL FEEDERS</b>	1.25	1.25	<b>DISTILLING (See Brewing)</b>		
Centrifugal	1.00	1.25	(Sewage)	1.00	1.25	<b>DOUBLE ACTING PUMPS</b>		
Lobe	1.25	1.50	<b>CLARIFIERS</b>	1.00	1.25	2 or More Cylinders	1.25	1.50
Vane	1.25	1.50	<b>CLASSIFIERS</b>	1.25	1.50	Single Cylinder	†	†
<b>BOTTLING MACHINERY</b>	1.00	1.25	<b>CLAY WORKING IND.</b>			<b>DOUGH MIXER (Food)</b>	1.25	1.50
<b>BREWING &amp; DISTILLING</b>			Brick Press	1.75	2.00	<b>DRAW BENCH (Metal)</b>		
Bottling Machinery	1.00	1.25	Briquette Machines	1.75	2.00	Mills) carriage & Main Drive	1.25	1.50
Brew Kettles, Cont. Duty	1.25	1.25	Pug Mills	1.25	1.50	<b>DREDGES</b>		
Can Filling Machines	1.00	1.25	<b>COLLECTORS (Sewage)</b>	1.25	1.25	Cable Reels, Conveyors	1.25	1.50
Cookers - Cont. Duty	1.25	1.25	<b>COMPRESSORS</b>			Cutter Head & Jig Drives	2.00	2.00
Mash Tubs - Cont. Duty	1.25	1.25	Centrifugal	1.00	1.25			
			Lobe	1.25	1.50			



## EASY SELECTION



## MagnaGear

Table 2: Service Factors (continued)

Application	Service		Application	Service		Application	Service	
	3-10 Hrs./Day	10+Hrs/Day		3-10 Hrs./Day	10+Hrs/Day		3-10 Hrs./Day	10+Hrs/Day
Maneuvering Winches	1.25	1.50	<b>COMPRESSORS</b>	1.25	1.50	with Helical Ring Gear		
Pumps	2.00	2.00	<b>LOG HAULS (Lumber)</b>			Direct connected		2.00
Screen Drives	1.75	2.00	Incline-well Type	1.75	1.75	<b>Cement Kilns, Dryers,</b>		
Stackers, Utility Winches	1.25	1.50	<b>LOOMS (Textile)</b>	1.25	1.50	Coolers, Pebble, Plain		
<b>DRY DOCK CRANES</b>	†	†	<b>LUMBER INDUSTRY</b>			& Wedge Bar Mills		1.50
<b>DRYERS &amp; COOLERS</b>			Barkers - Spindle Feed	1.25	1.50	Tumbling Barrels	1.75	2.00
(Mills, Rotary)		1.50	Barkers - Main Drive	1.75	1.75	<b>MIXERS (Also see Agitators)</b>		
<b>DYEING MACHINERY</b>			Carriage Drive	†	†	Concrete, Cont. & Int.	1.25	1.50
(Textile)	1.25	1.50	Conveyors			Constant Density	1.00	1.25
<b>ELEVATORS</b>			Burner	1.25	1.50	Variable Density	1.25	1.50
Bucket - Uniform Load	1.00	1.25	Main or Heavy Duty	1.50	1.50	<b>NAPPERS (Textile)</b>	1.25	1.50
Bucket - Heavy Duty	1.25	1.50	Main Log	1.75	2.00	<b>OIL INDUSTRY</b>		
Centrifugal Discharge	1.00	1.25	Re-Saw Merry-Go-			Chillers	1.25	1.50
Escalators	1.00	1.25	Round	1.25	1.50	Oil Well Pumping	†	†
Freight	1.25	1.50	Slab	1.75	2.00	Paraffin Filter Press	1.25	1.50
Gravity Discharge	1.00	1.25	Transfer	1.25	1.50	Rotary Kilns	1.25	1.50
Man. Lifts, Passenger	†	†	Chains - Floor	1.50	1.50	<b>ORE CRUSHERS</b>	1.75	2.00
<b>EXTRUDERS</b>			Chains - Green	1.50	1.75	<b>OVEN CONVEYORS</b>		
General	1.50	1.50	Cut-Off Saws - Chain			Uniform	1.00	1.25
Plastics			& Drag	1.50	1.75	Heavy Duty	1.25	1.50
Variable Speed Drive	1.50	1.50	Debarking Drums	1.75	2.00	<b>PAPER MILLS (1)</b>		
Fixed Speed Drive	1.75	1.75	Feeds - Edger	1.25	1.50	Agitator (Mixer)		1.50
Rubber			Feeds - Gang	1.75	1.75	Agitator for Pure Liquids		1.25
Continuous Screw			Feeds - Trimmer	1.25	1.50	Barking Drums, Barkers		
Operation	1.75	1.75	Log Deck	1.75	1.75	- Mech.		2.00
Intermittent Screw			Log Hauls - Incline,			Beater		1.50
Operation	1.75	1.75	Well Type	1.75	1.75	Breaker Stack		1.25
<b>FANS</b>			Log Turning Devices	1.75	1.75	Calender (2)		1.25
Centrifugal	1.00	1.25	Planer Feed	1.25	1.50	Chipper		2.00
Cooling Towers	†	†	Planer Tilting Hoists	1.25	1.50	Chip Feeder		1.50
Forced Draft	1.25	1.25	Rolls - Live - Off			Coating Rolls		1.25
Induced Draft	1.50	1.50	Bearing - Roll cases	1.75	1.75	Conveyors -		
Large (Mine, etc.)	1.50	1.50	Sorting Table, Tipple			Chip, Bark, Chemical		1.25
Large Industrial	1.50	1.50	Hoist	1.25	1.50	Log (Incl. Slab)		2.00
Light (Small Diameter)	1.00	1.25	Transfer - Chain &			Couch Rolls		1.25
<b>FEEDERS</b>			Craneway	1.50	1.75	Cutter		2.00
Apron, Belt	1.25	1.50	Tray Drives	1.25	1.50	Cylinder Molds		1.25
Disc	1.00	1.25	Veneer Lathe Drives	†	†	Dryers (2)		
Reciprocating	1.75	2.00	<b>MACHINE TOOLS</b>			Paper Mach. &		
Screw	1.25	1.50	Auxiliary Drives	1.00	1.25	Conveyor Type		1.25
<b>FLIGHT</b>			Banding Rolls	1.25	1.50	Embossor		1.25
Conveyors, Uniform	1.00	1.25	Main Drives	1.25	1.50	Extruder		1.50
Conveyors, Heavy	1.25	1.50	Notching Press (Belted)	†	†	Fourdrinier Rolls -		
<b>FOOD/INDUSTRY</b>			Plate Planers	1.75	2.00	Lumpbreaker, Wire		
Beet Slicers	1.25	1.50	Punch Press (Gearing)	1.75	2.00	Turning, Dandy &		
Bottling, Can Filling			Tapping Machines	1.75	2.00	Return Rolls		1.25
Machine	1.00	1.25	<b>MANGLE (Textile)</b>	1.25	1.50	Jordan		1.50
Cereal Cookers	1.00	1.25	<b>MASH TUBS (Brewing &amp;</b>			Kiln Drive		1.50
Dough Mixers, Meat			Distilling	1.25	1.25	Mt. Hope & Paper Rolls		1.25
Grinders	1.25	1.50	<b>MEAT GRINDERS (Food)</b>	1.25	1.50	Platter		1.50
<b>GENERATORS (Not</b>			<b>METAL MILLS</b>			Presses (Felt & Suction)		1.25
<b>Welding)</b>	1.00	1.25	Draw Bench Carriages			Pulper		2.00
<b>GRAVITY DISCHARGE</b>			& Main Drives	1.25	1.50	Reel (Surface Type)		1.25
<b>ELEVATORS</b>	1.00	1.25	Pinch, Dryer & Scrubber			Screens -		
<b>HAMMER MILLS</b>	1.75	2.00	Rolls Reversing	†	†	Chip, Rotary		1.50
<b>HOISTS (See Cranes)</b>	†	†	Slitters	1.25	1.50	Vibrating		2.00
<b>INDUCED DRAFT FANS</b>	1.50	1.50	Table Conveyors,			Size Press		1.25
<b>KILNS</b>	▲	▲	Non-Reversing			Super Calender (3)		1.25
<b>LAUNDRY</b>			Group Drives	1.50	1.50	Thickener & Washer -		
Tumblers	1.25	1.50	Individual Drives	2.00	2.00	AC Motor		1.50
Washers	1.50	2.00	Reversing	†	†	DC Motor		1.25
<b>LINE SHAFTS</b>			Wire Drawing &			Vacuum Pumps		1.50
Driving Processing			Flattening Machines			Wind & Unwind Stand		1.25
Equipment	1.25	1.50	Wire Winding Machines	1.50	1.50	Winders (Surface Type)		1.25
Other Line Shafts, Light	†	1.25	<b>MILLS, ROTARY</b>			Yankee Dryer (2)		1.25
<b>LIVE ROLL CONVEYORS</b>	†	†	Ball and Rod Mills			<b>PASSENGER ELEVATORS</b>	†	†
<b>LOBE BLOWERS OR</b>			with Spur Ring Gear		2.00	<b>PEBBLE MILLS</b>	▲	▲

## MagnaGear

**Table 2: Service Factors (continued)**

Application	Service		Application	Service		Application	Service	
	3-10 Hrs./Day	10+Hrs./Day		3-10 Hrs./Day	10+Hrs./Day		3-10 Hrs./Day	10+Hrs./Day
<b>PLASTICS INDUSTRY</b>			Mixing Mill-2smooth rolls (If corrugated rolls are used, then use the same service factors that are used for a Cracker-Warmer)	1.50	1.50	<b>SLITTERS (Metal)</b>	1.25	1.50
Primary Processing			Batch Drop Mill	1.50	1.50	<b>SLUDGE COLLECTORS (Sewage)</b>	1.25	1.25
Intensive Internal Mixers			2 Smooth Rolls	1.50	1.50	<b>SOAPERS (Textile)</b>	1.25	1.50
Batch Mixers	1.75	1.75	Cracker Warmer-2			<b>SPINNERS (Textile)</b>	1.25	1.50
Continuous Mixers	1.50	1.50	Rolls: 1 corrugated Roll	1.75	1.75	<b>STEERING GEARS</b>		
Batch Drop Mill - 2 Smooth Rolls	1.25	1.25	Cracker-2 corrugated	2.00	2.00	<b>STOKERS</b>	1.00	1.25
Continuous Feed, Holding & Blend Mill	1.25	1.25	Rolls	2.00	2.00	<b>STONE CRUSHERS</b>	1.75	2.00
Compounding Mill	1.25	1.25	Holding, Feed & Blend			<b>SUGAR INDUSTRY</b>		
Calenders	1.50	1.50	Mill-2 Rolls	1.25	1.25	Cane Knives, Crushers		
Secondary Processing			Refiner-2 Rolls	1.50	1.50	Mill		1.50
Blow Molders	1.50	1.50	Calenders	1.50	1.50	<b>TABLE CONVEYORS (Non-Reversing)</b>		
Coating	1.25	1.25	<b>SAND MULLERS</b>	1.25	1.50	Group Drives	1.50	1.50
Film	1.25	1.25	<b>SCREENS</b>			Individual Drives	2.00	2.00
Pipe	1.25	1.25	Air Washing	1.00	1.25	Reversing	†	†
Pre-Plasticizers	1.50	1.50	Rotary-Sand or Gravel	1.25	1.50	<b>TENTER FRAMES (Textile)</b>	1.25	1.50
Rods	1.25	1.25	Traveling Water Intake	1.00	1.25	<b>TEXTILE INDUSTRY</b>		
Sheets	1.25	1.25	<b>SCREW CONVEYORS</b>			Batchers, calenders	1.25	1.50
Tubing	1.25	1.50	Uniform	1.00	1.25	Card Machines	1.25	1.50
<b>PLATE PLANERS</b>	1.75	2.00	Heavy Duty or Feeder	1.25	1.50	Dry Cans, Dryers	1.25	1.50
<b>PRINTING PRESSES</b>	†	†	<b>SCUM BREAKERS (Sewage)</b>	1.50	1.50	Dyeing Machinery	1.25	1.50
<b>PROPORTIONING PUMPS</b>	1.25	1.50	SEWAGE DISPOSAL			Knitting Machinery	†	†
<b>PUG MILLS (Clay)</b>	1.25	1.50	Bar Screens	1.25	1.25	Looms, Mangles		
<b>PULLERS (Barge Haul)</b>	1.25	1.50	Chemical Feeders	1.25	1.25	Nappers, Pads	1.25	1.50
<b>PUMPS</b>			Collectors	1.25	1.25	Range Drives	†	†
Centrifugal	1.00	1.25	Dewatering Screens	1.50	1.50	Slashers, Soapers		
Proportioning	1.25	1.50	Scum Breakers	1.50	1.50	Spinners	1.25	1.50
Reciprocating			Slow or Rapid Mixers	1.50	1.50	Tenter Framers,		
Single Act., 3 or More Cyl.	1.25	1.50	Thickeners	1.50	1.50	Washers, Winders	1.25	1.50
Double Act, 2 or More Cyl.	1.25	1.50	Vacuum Filters	1.50	1.50	<b>THICKNESS (Sewage)</b>	1.50	1.50
Single Act., 1 or 2 Cyl.	†	†	<b>SHAKER CONVEYORS</b>	1.75	2.00	<b>TUMBLING BARRELS</b>	1.75	2.00
Double Act, 1 Cyl.	†	†	<b>SHEETERS (Rubber)</b>			<b>VACUUM FILTERS (Sewage)</b>	1.50	1.50
Rotary: Gear, Lobe, Vane	1.00	1.25	<b>SINGLE ACTING PUMP</b>			<b>VANE BLOWERS</b>	1.25	1.50
<b>PUNCH PRESS</b>			1 or 2 Cylinders	†	†	<b>WINCHES (Dredges)</b>	1.25	1.50
; (Gear Driven)	1.75	2.00	3 or More Cylinders	1.25	1.50	<b>WINDERS (Textile)</b>	1.25	1.50
<b>RECIPROCATING</b>			<b>SKIP HOIST</b>	†	†	<b>WINDGLASS</b>	†	†
Conveyors, Feeders	1.75	2.00	<b>SLAB PUSHERS</b>	1.50	1.50	<b>WIRE</b>		
<b>RECIPROCATING COMPRESSORS</b>						Drawing Machines	1.25	1.50
Multi Cylinder	1.50	1.75				Winding Machines	1.50	1.50
Single Cylinder	1.75	2.00						
<b>REVERSING DIRECTION APPLICATION</b>	†	†						
<b>ROD MILLS</b>	▲	▲						
<b>ROTARY</b>								
Pumps	1.00	1.25						
Screens (Sand and Gravel)	1.25	1.50						
<b>RUBBER INDUSTRY</b>								
Intensive Internal Mixers								
Batch Mixers	1.75	1.75						
	1.50	1.50						

† Consult DODGE  
 ▲ See Mill, Rotary  
 (1) Service factors for paper mill applications are applied to the nameplate rating of the electric motor at the motor rated base speed  
 (2) Using anti-friction bearings only. Use 1.50 for sleeve bearings  
 (3) When a super calender operates over a speed range of part constant horsepower and part constant torque and the constant horsepower speed range is greater than 1.5:1, use a service factor of 1.00 at base speed. When operating at constant torque over the entire speed range or when the constant horsepower speed range is less than 1.5:1, a 1.25 service factor should be used.

## EASY SELECTION



## Parallel - MagnaGear Reducers 1750 RPM - 1.0 Service Factor

Nominal Ratio	Approx. Low Speed Shaft RPM	Unit Red.	MagnaGear Offset Parallel Reducer Size Used with Motor Horsepower of:									
			50	75	100	125	150	200	250	300	350	400
8.00	219	D O U B L E	100	100	100	100❖	100❖	100❖	100●	150●	150●	150●
9.00	194		100	100	100	100❖	100❖	100❖	100●	150●	150●	150●
10.0	175		100	100	100	100❖	100❖	100❖	100●	150●	150●	150●
11.2	156		100	100	100	100❖	100❖	100●	150●	150●	150●	210●
12.5	140		100	100	100	100❖	100❖	100●	150●	150●	210●	210●
14.0	125		100	100	100	100❖	100❖	150❖	150●	210❖	210●	285●
16.0	109		100	100	100	100❖	100❖	150❖	210❖	210●	210●	285●
18.0	97		100	100	100	100❖	150❖	150❖	210❖	210●	285●	285●
20.0	88		100	100	100	100❖	150❖	150❖	210❖	285❖	285●	285●
22.4	78		100	100	100❖	150❖	150❖	210❖	210❖	285❖	390●	390●
25.0	70	T R I P L E	100	100	100❖	150❖	150❖	210❖	285❖	285❖	390●	390●
28.0	63		100	100	150	150❖	210❖	210❖	285❖	390❖	390●	525●
31.5	56		100	100	150	150❖	210❖	285❖	285❖	390●	390●	-
35.5	49		100	100	150	210	210❖	285❖	390❖	390●	-	-
40.0	44		100	150	150	210	210❖	285❖	390❖	-	-	-
45.0	39		100	150	210	210	285	390❖	390❖	-	-	-
50.0	35		100	150	210	285	285	390❖	-	-	-	-
56.0	31		100	150	210	285	285	-	-	-	-	-
63.0	28		150	210	285	285	390	-	-	-	-	-

Nominal Ratio	Approx. Low Speed Shaft RPM	Unit Red.	MagnaGear Offset Parallel Reducer Size Used with Motor Horsepower of:										
			500	600	700	800	900	1000	1100	1200	1300	1400	
8.00	219	D O U B L E	210●	210■	285■	285■	285■	390■	390■	390■	525■	525■	
9.00	194		210●	285●	285■	285■	390■	390■	390■	525■	525■	525■	525■
10.0	175		210●	285●	285■	390●	390■	390■	525■	525■	525■	700■	700■
11.2	156		285●	285●	390●	390■	390■	525■	525■	525■	700■	700■	700■
12.5	140		285●	285●	390●	390■	525●	525■	525■	700■	700■	700■	700■
14.0	125		285●	390●	390●	525●	525●	525■	700■	700■	700■	920■	920■
16.0	109		285●	390●	525●	525●	525■	700●	700■	700■	920■	920■	920■
18.0	97		390●	525●	525●	525●	700●	700●	700■	700■	920■	920■	920■
20.0	88		390●	525●	525●	700●	700●	700●	920●	920■	-	-	-
22.4	78		525●	525●	525●	700●	700●	920●	920■	-	-	-	-
25.0	70	525●	525●	700●	700●	920●	920●	-	-	-	-	-	
28.0	63	525●	700●	700●	920●	920●	-	-	-	-	-	-	

- ❖ Shaft Driven Cooling Fan Required
- Electric Cooling Fan Required
- Heat Exchanger Required

NOTE: Cooling systems selected for 80°F ambient temperature and sea level altitude. If actual installation conditions differ, use thermal ratings tables and adjustment factors starting on page 86.

## Parallel - MagnaGear Reducers 1750 RPM - 1.5 Service Factor

Nominal Ratio	Approx. Low Speed Shaft RPM	Unit Red.	MagnaGear Offset Parallel Reducer Size Used with Motor Horsepower of:									
			50	75	100	125	150	200	250	300	350	400
8.00	219	D O U B L E	100	100	100	100❖	100❖	150❖	150❖	150●	210●	210●
9.00	194		100	100	100	100❖	100❖	150❖	150❖	210❖	210●	285❖
10.0	175		100	100	100	100❖	100❖	150❖	150❖	210❖	210●	285❖
11.2	156		100	100	100	100❖	150❖	150❖	210❖	210❖	285❖	285●
12.5	140		100	100	100	100❖	150❖	150❖	210❖	285❖	285❖	285●
14.0	125		100	100	100	150	150❖	210❖	210❖	285❖	285❖	390●
16.0	109		100	100	100	150	150❖	210❖	285❖	285❖	390❖	390●
18.0	97		100	100	150	150	150❖	210❖	285❖	285❖	390❖	525
20.0	88		100	100	150	150	210	285❖	285❖	390❖	390❖	525
22.4	78		100	100	150	150❖	210❖	285❖	390❖	390❖	525❖	525●
25.0	70	T R I P L E	100	150	150	210	210❖	285❖	390❖	525❖	525❖	525●
28.0	63		100	150	210	210	285	390❖	390❖	525❖	525❖	700
31.5	56		100	150	210	210	285	390❖	-	-	-	-
35.5	49		100	150	210	285	285	390❖	-	-	-	-
40.0	44		150	210	210	285	390	-	-	-	-	-
45.0	39		150	210	285	285	390	-	-	-	-	-
50.0	35		150	210	285	390	390	-	-	-	-	-
56.0	31		150	210	285	390	-	-	-	-	-	-
63.0	28		210	285	390	390	-	-	-	-	-	-

Nominal Ratio	Approx. Low Speed Shaft RPM	Unit Red.	MagnaGear Offset Parallel Reducer Size Used with Motor Horsepower of:									
			500	600	700	800	900	1000	1100	1200	1300	1400
8.00	219	D O U B L E	285●	285●	390●	390●	525●	525■	700●	700■	700■	700■
9.00	194		285●	390●	390●	525●	525●	700●	700●	700■	700■	920■
10.0	175		285●	390●	390●	525●	525●	700●	700●	700■	920■	920■
11.2	156		390●	390●	525●	525●	700●	700●	700■	920●	920■	920■
12.5	140		390●	525●	525●	700●	700●	700●	920●	920●	920■	-
14.0	125		390●	525●	525●	700●	700●	920●	920●	920●	-	-
16.0	109		525●	525●	700●	700●	920●	920●	-	-	-	-
18.0	97		525●	700●	700●	920●	920●	-	-	-	-	-
20.0	88		525●	700●	920●	920●	-	-	-	-	-	-
22.4	78		525●	700●	920●	-	-	-	-	-	-	-
25.0	70	700●	920●	920●	-	-	-	-	-	-	-	
28.0	63	920●	920●	-	-	-	-	-	-	-	-	

- ❖ Shaft Driven Cooling Fan Required
- Electric Cooling Fan Required
- Heat Exchanger Required

NOTE: Cooling systems selected for 80°F ambient temperature and sea level altitude. If actual installation conditions differ, use thermal ratings tables and adjustment factors starting on page 86.

## EASY SELECTION



## Parallel - MagnaGear Reducers 1750 RPM - 2.0 Service Factor

Nominal Ratio	Approx. Low Speed Shaft RPM	Unit Red.	MagnaGear Offset Parallel Reducer Size Used with Motor Horsepower of:									
			50	75	100	125	150	200	250	300	350	400
8.00	219	D O U B L E	100	100	100	100❖	150❖	150❖	210❖	210❖	285❖	285❖
9.00	194		100	100	100	100❖	150❖	150❖	210❖	285❖	285❖	285❖
10.0	175		100	100	100	150	150❖	210❖	210❖	285❖	285❖	390❖
11.2	156		100	100	100	150	150❖	210❖	285❖	285❖	390❖	390●
12.5	140		100	100	100	150	150❖	210❖	285❖	285❖	390❖	390●
14.0	125		100	100	150	150	210	285	285❖	390❖	390❖	525❖
16.0	109		100	100	150	210	210	285❖	285❖	390❖	525❖	525❖
18.0	97		100	150	150	210	210	285❖	390❖	525❖	525❖	525❖
20.0	88		100	150	150	210	285	285❖	390❖	525❖	525❖	700❖
22.4	78		100	150	210	210	285	390❖	525❖	525❖	525❖	700❖
25.0	70	T R I P L E	100	150	210	285	285	390❖	525❖	525❖	700❖	700❖
28.0	63		150	210	210	285	390	525❖ (1)	525❖	700❖	700❖	920❖
31.5	56		150	210	285	285	390	-	-	-	-	-
35.5	49		150	210	285	390	390	-	-	-	-	-
40.0	44		150	210	285	390	-	-	-	-	-	-
45.0	39		210	285	390	390	-	-	-	-	-	-
50.0	35		210	285	390	-	-	-	-	-	-	-
56.0	31		210	285	-	-	-	-	-	-	-	-
63.0	28		285	390	-	-	-	-	-	-	-	-

Nominal Ratio	Approx. Low Speed Shaft RPM	Unit Red.	MagnaGear Offset Parallel Reducer Size Used with Motor Horsepower of:									
			500	600	700	800	900	1000	1100	1200	1300	1400
8.0	219	D O U B L E	390●	390●	525●	700●	700●	700●	920●	920●	920■	920■
9.0	194		390●	525●	525●	700●	700●	700●	920●	920●	920■	-
10.0	175		390●	525●	700●	700●	700●	920●	920●	920●	-	-
11.2	156		525●	525●	700●	700●	920●	920●	-	-	-	-
12.50	140		525●	700●	700●	920●	920●	-	-	-	-	-
14.0	125		525●	700●	920●	920●	-	-	-	-	-	-
16.0	109		700	700●	920●	920●	-	-	-	-	-	-
18.0	97		700	920●	920●	-	-	-	-	-	-	-
20.0	88		700	920●	-	-	-	-	-	-	-	-
22.4	78		920	-	-	-	-	-	-	-	-	-
25.0	70		920	-	-	-	-	-	-	-	-	-

- ❖ Shaft Driven Cooling Fan Required
- Electric Cooling Fan Required
- Heat Exchanger Required
- (1) Double Reduction

NOTE: Cooling systems selected for 80°F ambient temperature and sea level altitude.  
If actual installation conditions differ, use thermal ratings tables and adjustment factors starting on page 86.

## Right Angle - MagnaGear Reducers 1750 RPM - 1.0 Service Factor

Nominal Ratio	Approx. Low Speed Shaft RPM	Unit Red.	MagnaGear Right Angle Reducer Size Used with Motor Horsepower of:									
			50	75	100	125	150	200	250	300	350	400
12.5	140	T R I P L E	100	100	100❖	100❖	100❖	100●	150●	150●	210●	210●
14.0	125		100	100	100❖	100❖	100❖	150❖	150●	210●	210●	210●
16.0	109		100	100	100❖	100❖	100❖	150❖	150●	210●	210●	285●
18.0	97		100	100	100❖	100❖	150❖	150❖	210❖	210●	285●	285●
20.0	88		100	100	100❖	100❖	150❖	150●	210●	285●	285●	390●
22.4	78		100	100	100❖	150❖	150❖	210❖	210●	285●	285●	390●
25.0	70		100	100	100❖	150❖	150❖	210❖	285	285●	390●	390●
28.0	63		100	100	150❖	150❖	150❖	210❖	285	390●	390●	525●
31.5	56		100	100	150❖	150❖	210❖	285❖	285●	390●	525●	525●
35.5	49		100	100	150❖	210❖	210❖	285❖	390●	390●	525●	525●
40.0	44		100	150	150❖	210❖	285❖	285❖	390●	525●	525●	525●
45.0	39		100	150	210	210❖	285❖	390❖	525❖	525●	525●	700●
50.0	35		100	150	210	285❖	285❖	390●	525●	525●	700●	700●
56.0	31		100	150	210	285❖	285❖	390●	525●	700●	700●	920●
63.0	28		150	210	210	285❖	390❖	525❖	525●	700●	700●	920●

Nominal Ratio	Approx. Low Speed Shaft RPM	Unit Red.	MagnaGear Right Angle Reducer Size Used with Motor Horsepower of:									
			500	600	700	800	900	1000	1100	1200	1300	1400
12.5	140	T R I P L E	285●	390●	525●	525■	525■	525■	700■	700■	700■	700■
14.0	125		285●	390●	525●	525■	525■	525■	700■	700■	700■	700■
16.0	109		390●	390●	525●	525■	525■	700■	700■	700■	920■	920■
18.0	97		390●	525●	525●	525■	700■	700■	700■	920■	920■	920■
20.0	88		390●	525●	525■	700■	700■	700■	920■	920■	920■	-
22.4	78		525●	525●	525■	700■	700■	920■	920■	920■	-	-
25.0	70		525●	525●	700●	920●	920■	920■	-	-	-	-
28.0	63		525●	700●	700●	920●	920■	-	-	-	-	-
31.5	56		700●	700●	920■	920■	-	-	-	-	-	-
35.5	49		700●	920●	920■	-	-	-	-	-	-	-
40.0	44		700●	920●	-	-	-	-	-	-	-	-
45.0	39		920●	920●	-	-	-	-	-	-	-	-
50.0	35		920●	-	-	-	-	-	-	-	-	-
56.0	31		920●	-	-	-	-	-	-	-	-	-
63.0	28		-	-	-	-	-	-	-	-	-	-

- ❖ Shaft Driven Cooling Fan Required
- Electric Cooling Fan Required
- Heat Exchanger Required

NOTE: Cooling systems selected for 80°F ambient temperature and sea level altitude. If actual installation conditions differ, use thermal ratings tables and adjustment factors starting on page 86.

## EASY SELECTION



## Right Angle - MagnaGear Reducers 1750 RPM - 1.5 Service Factor

Nominal Ratio	Approx. Low Speed Shaft RPM	Unit Red.	MagnaGear Right Angle Reducer Size Used with Motor Horsepower of:									
			50	75	100	125	150	200	250	300	350	400
12.5	140	T R I P L E	100	100	100❖	100❖	150❖	150❖	210❖	210●	285●	390●
14.0	125		100	100	100❖	150❖	150❖	210❖	210❖	210●	285●	390●
16.0	109		100	100	100❖	150❖	150❖	210❖	285❖	285❖	390●	390●
18.0	97		100	100	150	150❖	150❖	210❖	285❖	285❖	390●	525❖
20.0	88		100	100	150	150	210❖	285❖	285❖	390●	390●	525●
22.4	78		100	100	150	210	210❖	285❖	390❖	390●	525❖	525●
25.0	70		100	150	150	210	210❖	285❖	390❖	390●	525❖	525●
28.0	63		100	150	150	210	285	390❖	390❖	525❖	525❖	700❖
31.5	56		100	150	210	210❖	285❖	390❖	525❖	525●	700●	700●
35.5	49		100	150	210	285	285❖	390❖	525❖	525●	700●	920●
40.0	44		100	210	285	285	390❖	525❖	525❖	525●	700●	920●
45.0	39		100	210	285	285	390❖	525❖	700❖	700❖	920●	920●
50.0	35		100	210	285	390	525❖	525❖	700❖	700●	920●	-
56.0	31		100	285	285	390	525❖	700❖	700❖	920●	-	-
63.0	28		150	285	390	525	525❖	700❖	920❖	920●	-	-

Nominal Ratio	Approx. Low Speed Shaft RPM	Unit Red.	MagnaGear Right Angle Reducer Size Used with Motor Horsepower of:									
			500	600	700	800	900	1000	1100	1200	1300	1400
12.5	140	T R I P L E	525●	525●	700●	700●	700■	920■	920■	920■	-	-
14.0	125		525●	525●	700●	700●	700■	920■	920■	920■	-	-
16.0	109		525●	525●	700●	700●	920●	920■	-	-	-	-
18.0	97		525●	700●	700●	920●	920●	-	-	-	-	-
20.0	88		525●	700●	920●	920●	-	-	-	-	-	-
22.4	78		700●	700●	920●	920●	-	-	-	-	-	-
25.0	70		700●	920●	920●	-	-	-	-	-	-	-
28.0	63		920●	920●	-	-	-	-	-	-	-	-
31.5	56		920●	-	-	-	-	-	-	-	-	-
35.5	49		920●	-	-	-	-	-	-	-	-	-
40.0	44		-	-	-	-	-	-	-	-	-	-
45.0	39		-	-	-	-	-	-	-	-	-	-
50.0	35		-	-	-	-	-	-	-	-	-	-
56.0	31		-	-	-	-	-	-	-	-	-	-
63.0	28		-	-	-	-	-	-	-	-	-	-

- ❖ Shaft Driven Cooling Fan Required
- Electric Cooling Fan Required
- Heat Exchanger Required

NOTE: Cooling systems selected for 80°F ambient temperature and sea level altitude.  
If actual installation conditions differ, use thermal ratings tables and adjustment factors starting on page 86.

## Right Angle - MagnaGear Reducers 1750 RPM - 2.0 Service Factor

Nominal Ratio	Approx. Low Speed Shaft RPM	Unit Red.	MagnaGear Right Angle Reducer Size Used with Motor Horsepower of:									
			50	75	100	125	150	200	250	300	350	400
12.5	140	T R I P L E	100	100	100❖	150❖	150❖	210❖	285❖	390❖	525❖	525❖
14.0	125		100	100	150	150❖	210	210❖	285❖	390❖	525❖	525❖
16.0	109		100	100	150	150❖	210	285❖	390❖	390❖	525❖	525❖
18.0	97		100	150	150	210	210	285❖	390❖	525❖	525❖	525❖
20.0	88		100	150	150	210	285	390❖	390❖	525❖	525❖	700❖
22.4	78		100	150	210	210	285	390❖	525❖	525❖	525❖	700❖
25.0	70		100	150	210	285	285	390❖	525❖	525❖	700❖	920❖
28.0	63		150	150	210	285	390	525❖	525❖	700❖	700❖	920❖
31.5	56		150	210	285	285	390❖	525❖	700❖	700❖	920❖	920●
35.5	49		150	210	285	390	390❖	525❖	700❖	920❖	920❖	-
40.0	44		150	285	285	390	525❖	525❖	700❖	920❖	-	-
45.0	39		210	285	390	525	525❖	700❖	920❖	920❖	-	-
50.0	35		210	285	390	525	525❖	700❖	920❖	-	-	-
56.0	31		210	285	390	525	700❖	920❖	920❖	-	-	-
63.0	28		210	390	525	525	700❖	920❖	-	-	-	-

Nominal Ratio	Low Speed Shaft RPM	Unit Red.	MagnaGear Right Angle Reducer Size Used with Motor Horsepower of:									
			500	600	700	800	900	1000	1100	1200	1300	1400
12.5	140	T R I P L E	525●	700●	700●	920●	-	-	-	-	-	-
14.0	125		525●	700●	700●	920●	-	-	-	-	-	-
16.0	109		700●	700●	920●	920●	-	-	-	-	-	-
18.0	97		700●	920●	920●	-	-	-	-	-	-	-
20.0	88		700●	920●	-	-	-	-	-	-	-	-
22.4	78		920●	920●	-	-	-	-	-	-	-	-
25.0	70		920●	-	-	-	-	-	-	-	-	-
28.0	63		-	-	-	-	-	-	-	-	-	-
31.5	56		-	-	-	-	-	-	-	-	-	-
35.5	49		-	-	-	-	-	-	-	-	-	-
40.0	44		-	-	-	-	-	-	-	-	-	-
45.0	39		-	-	-	-	-	-	-	-	-	-
50.0	35		-	-	-	-	-	-	-	-	-	-
56.0	31		-	-	-	-	-	-	-	-	-	-
63.0	28		-	-	-	-	-	-	-	-	-	-

- ❖ Shaft Driven Cooling Fan Required
- Electric Cooling Fan Required
- Heat Exchanger Required

NOTE: Cooling systems selected for 80°F ambient temperature and sea level altitude. If actual installation conditions differ, use thermal ratings tables and adjustment factors starting on page 86.



## MagnaGear G100 Parallel Shaft Part Numbers

Nominal Ratio			Solid Shaft	Solid Shaft with Backstop	Hollow Shaft	Hollow Shaft with Backstop
D O U B L E	G100HP2	8.00	<b>449024</b>	<b>449037</b>	<b>448998</b>	<b>449012</b>
	G100HP2	9.00	<b>449025</b>	<b>449038</b>	<b>449000</b>	<b>449013</b>
	G100HP2	10.0	<b>449026</b>	<b>449039</b>	<b>449001</b>	<b>449014</b>
	G100HP2	11.2	<b>449027</b>	<b>449040</b>	<b>449002</b>	<b>449015</b>
	G100HP2	12.5	<b>449028</b>	<b>449041</b>	<b>449003</b>	<b>449016</b>
	G100HP2	14.0	<b>449029</b>	<b>449042</b>	<b>449004</b>	<b>449017</b>
	G100HP2	16.0	<b>449030</b>	<b>449043</b>	<b>449006</b>	<b>449018</b>
	G100HP2	18.0	<b>449032</b>	<b>449044</b>	<b>449007</b>	<b>449019</b>
	G100HP2	20.0	<b>449033</b>	<b>449045</b>	<b>449008</b>	<b>449020</b>
T R I P L E	G100HP3	25.0	<b>448979</b>	<b>448988</b>	<b>448960</b>	<b>448969</b>
	G100HP3	28.0	<b>448980</b>	<b>448989</b>	<b>448961</b>	<b>448971</b>
	G100HP3	31.5	<b>448981</b>	<b>448990</b>	<b>448962</b>	<b>448972</b>
	G100HP3	35.5	<b>448982</b>	<b>448991</b>	<b>448963</b>	<b>448973</b>
	G100HP3	40.0	<b>448983</b>	<b>448992</b>	<b>448964</b>	<b>448974</b>
	G100HP3	45.0	<b>448984</b>	<b>448993</b>	<b>448965</b>	<b>448975</b>
	G100HP3	50.0	<b>448985</b>	<b>448994</b>	<b>448966</b>	<b>448976</b>
	G100HP3	56.0	<b>448986</b>	<b>448995</b>	<b>448967</b>	<b>448977</b>
	G100HP3	63.0	<b>448987</b>	<b>448996</b>	<b>448968</b>	<b>448978</b>

## MagnaGear G100 Right Angle Shaft Part Numbers

Nominal Ratio			Solid Shaft	Solid Shaft with Backstop	Hollow Shaft	Hollow Shaft with Backstop
T R I P L E	G100HR3	12.5	<b>448930</b>	<b>448945</b>	<b>448900</b>	<b>448915</b>
	G100HR3	14.0	<b>448931</b>	<b>448946</b>	<b>448901</b>	<b>448916</b>
	G100HR3	16.0	<b>448932</b>	<b>448947</b>	<b>448902</b>	<b>448917</b>
	G100HR3	18.0	<b>448933</b>	<b>448948</b>	<b>448903</b>	<b>448918</b>
	G100HR3	20.0	<b>448934</b>	<b>448949</b>	<b>448904</b>	<b>448919</b>
	G100HR3	22.4	<b>448935</b>	<b>448950</b>	<b>448905</b>	<b>448920</b>
	G100HR3	25.0	<b>448936</b>	<b>448951</b>	<b>448906</b>	<b>448921</b>
	G100HR3	28.0	<b>448937</b>	<b>448952</b>	<b>448907</b>	<b>448922</b>
	G100HR3	31.5	<b>448938</b>	<b>448953</b>	<b>448908</b>	<b>448923</b>
	G100HR3	35.5	<b>448939</b>	<b>448954</b>	<b>448909</b>	<b>448924</b>
	G100HR3	40.0	<b>448940</b>	<b>448955</b>	<b>448910</b>	<b>448925</b>
	G100HR3	45.0	<b>448941</b>	<b>448956</b>	<b>448911</b>	<b>448926</b>
	G100HR3	50.0	<b>448942</b>	<b>448957</b>	<b>448912</b>	<b>448927</b>
	G100HR3	56.0	<b>448943</b>	<b>448958</b>	<b>448913</b>	<b>448928</b>
G100HR3	63.0	<b>448944</b>	<b>448959</b>	<b>448914</b>	<b>448929</b>	

## G100 Accessory Part Numbers Shaft Driven Fan Kits

MagnaGear	Shaft Configuration	Reduction	Ratio	Part Number
G100HP2	Parallel	Double	8 - 22.4	<b>454007</b>
G100HP3	Parallel	Triple	25 - 63	<b>454006</b>
G100HR3	Right Angle	Triple	12.5 - 63	<b>454005</b>

Mechanical fan kit includes fan, fan shroud, fan guard and mounting hardware.

## Electric Fan Kits

MagnaGear	Shaft Configuration	Reduction	Ratio	Voltage	Phase	Part Number
All G100	All	All	All	230/460	3	<b>454096</b>
All G100	All	All	All	115	1	<b>454097</b>
All G100	All	All	All	230	1	<b>452287</b>
All G100	All	All	All	575	3	<b>454080</b>

Electrical fan kit includes fan, electric motor, fan shroud, fan guard and mounting hardware.

# SELECTION/DIMENSIONS



## MagnaGear G100 Parallel Shaft DOUBLE REDUCTION (8:1 TO 22.4:1) SOLID OUTPUT SHAFT

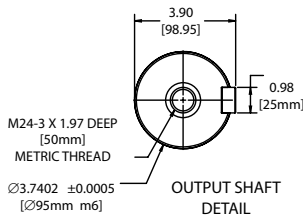
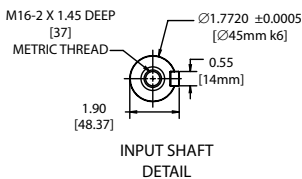
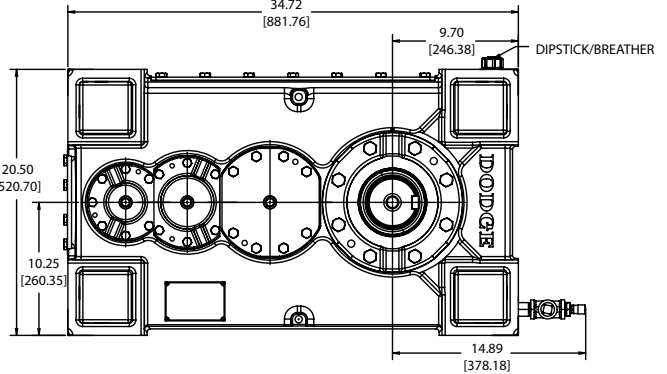
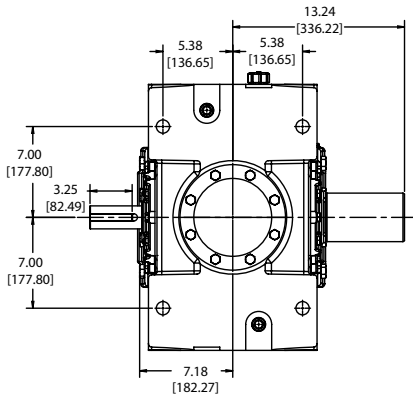
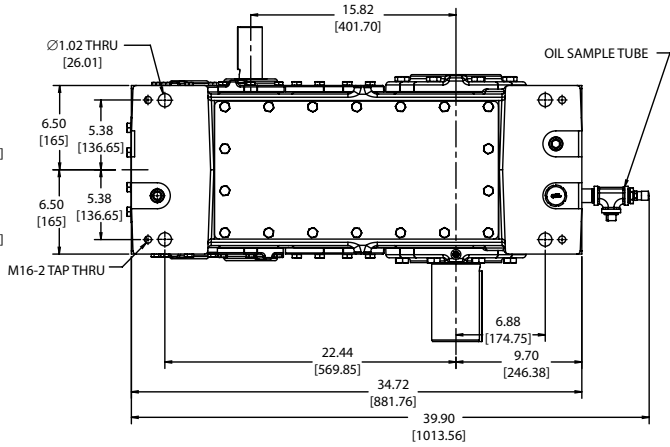
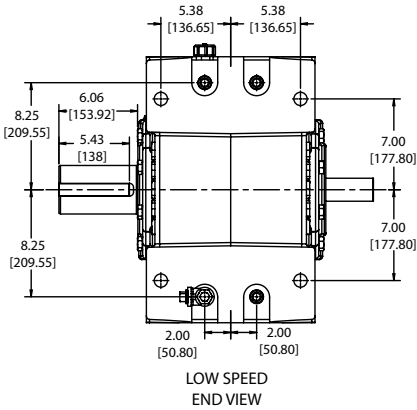

Weight without oil: 1138 lbs  
 Dimensions in [ ] are millimeters.  
 Drawing for reference only. Contact DODGE for certified drawing.

# SELECTION/DIMENSIONS



## MagnaGear G100 Parallel Shaft TRIPLE REDUCTION (25:1 TO 63:1) SOLID OUTPUT SHAFT

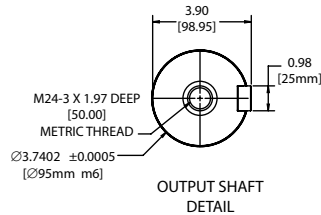
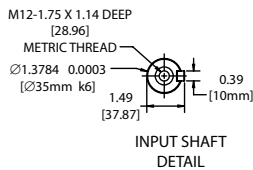
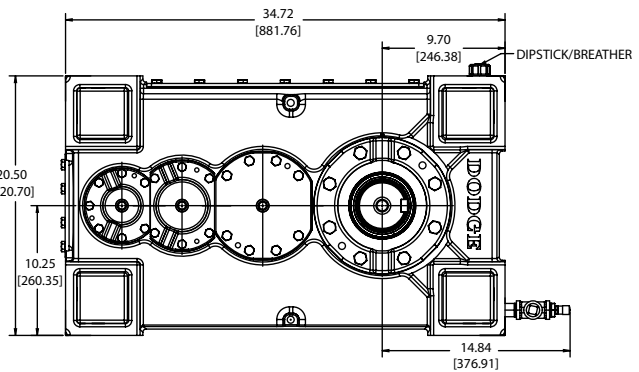
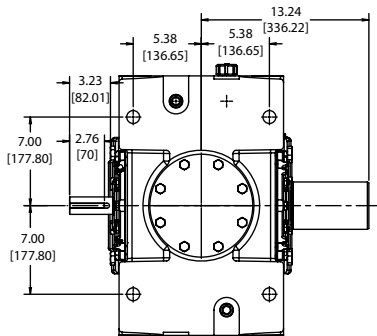
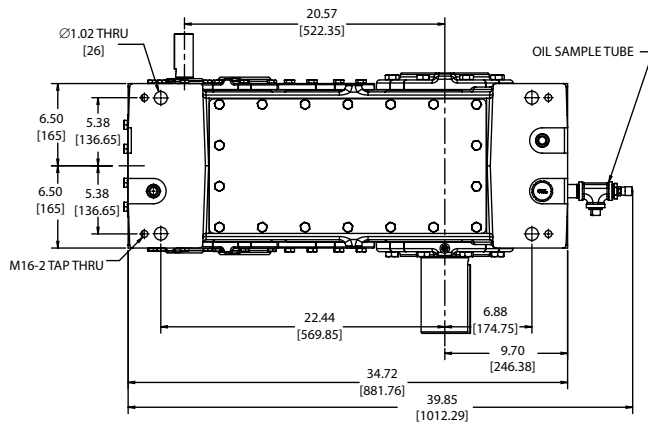
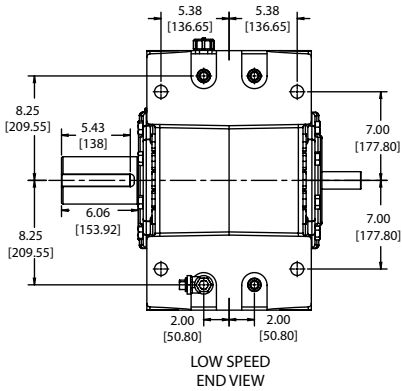

Weight without oil: 1163 lbs  
Dimensions in [ ] are millimeters.  
Drawing for reference only. Contact DODGE for certified drawing.

Features/Benefits

Specifications

Nomenclature

Easy Selection

Selection/Dimensions

# SELECTION/DIMENSIONS



## MagnaGear G100 Right Angle Shaft TRIPLE REDUCTION (12.5:1 TO 63:1) SOLID OUTPUT SHAFT

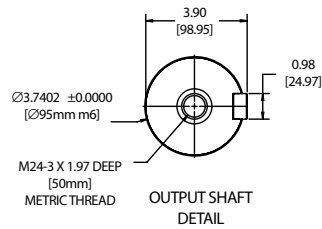
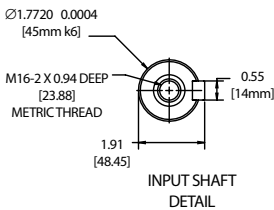
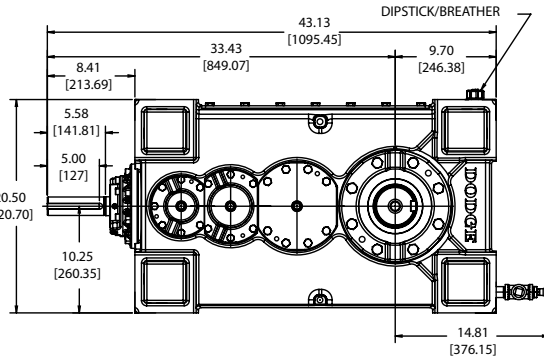
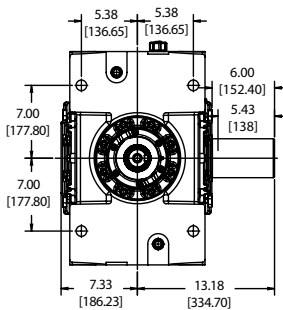
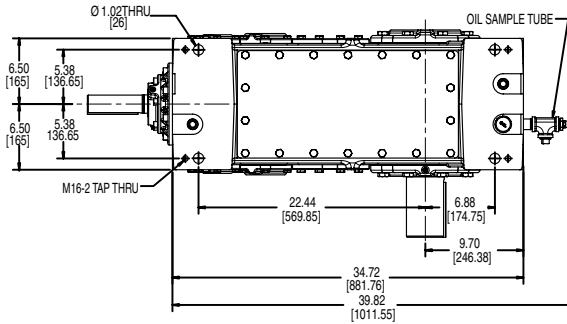
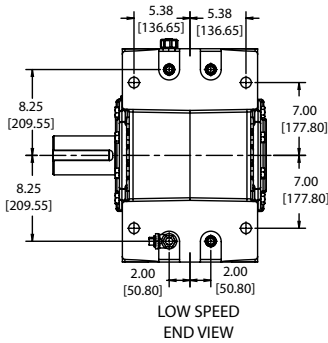

Weight without oil: 1245 lbs  
 Dimensions in [ ] are millimeters.  
 Drawing for reference only. Contact DODGE for certified drawing.

# SELECTION/DIMENSIONS



## MagnaGear G100 Parallel Shaft DOUBLE REDUCTION (8:1 TO 22.4:1) HOLLOW OUTPUT SHAFT

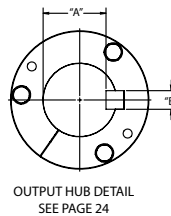
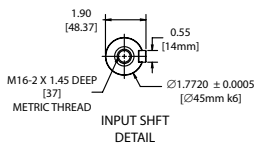
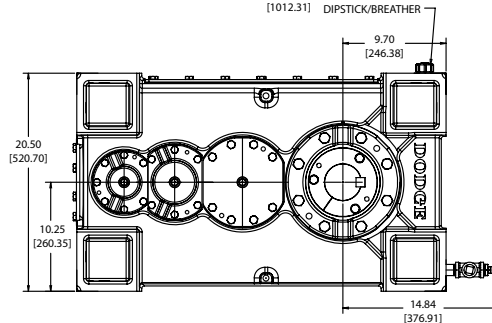
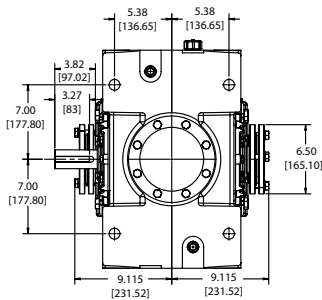
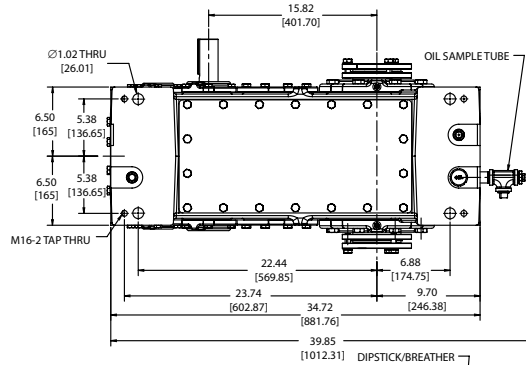
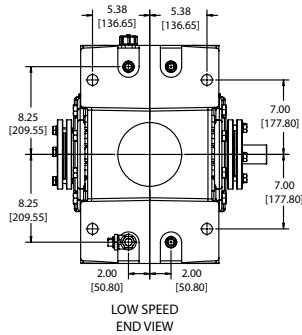

Weight without oil: 1103 lbs  
Dimensions in [ ] are millimeters.  
Drawing for reference only. Contact DODGE for certified drawing.

# SELECTION/DIMENSIONS



## MagnaGear G100 Parallel Shaft TRIPLE REDUCTION (25:1 TO 63:1) HOLLOW OUTPUT SHAFT

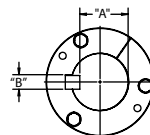
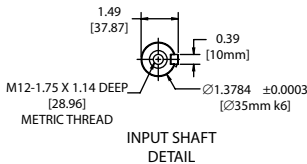
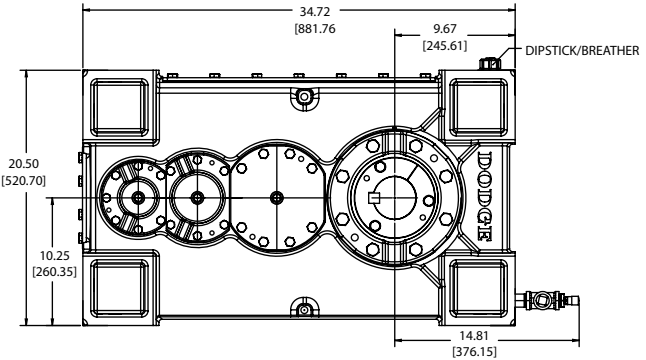
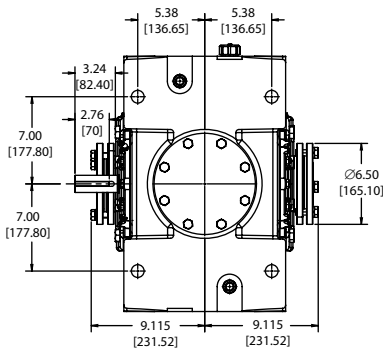
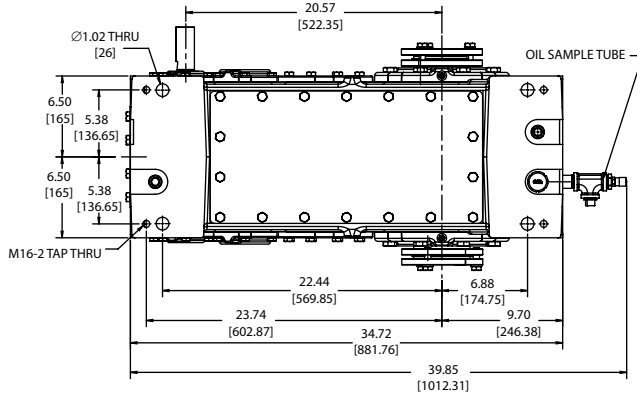
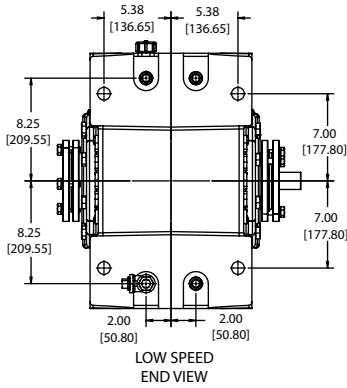

OUTPUT HUB DETAIL  
SEE PAGE 24

Weight without oil: 1127 lbs  
Dimensions in [ ] are millimeters.  
Drawing for reference only. Contact DODGE for certified drawing.

# SELECTION/DIMENSIONS



## MagnaGear G100 Right Angle Shaft TRIPLE REDUCTION (12.5:1 TO 63:1) HOLLOW OUTPUT SHAFT

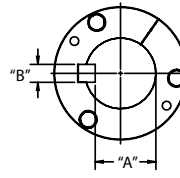
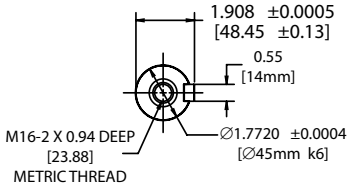
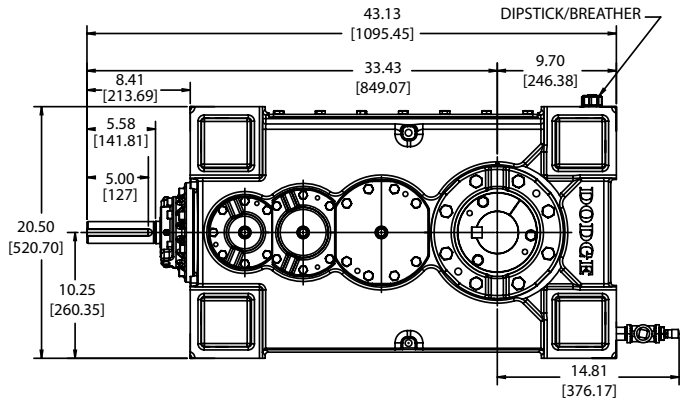
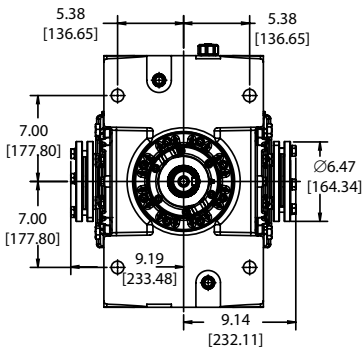
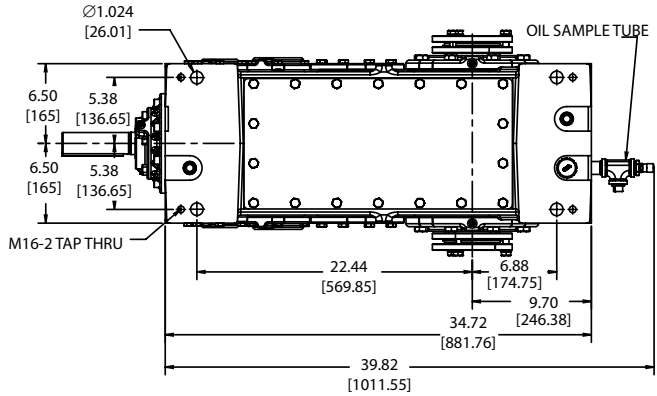
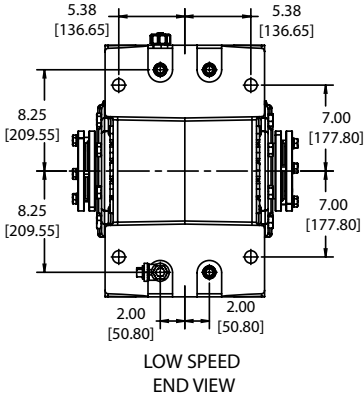

OUTPUT HUB  
DETAIL  
SEE PAGE 24

Weight without oil: 1210 lbs  
Dimensions in [ ] are millimeters.  
Drawing for reference only. Contact DODGE for certified drawing.

Features/Benefits

Specifications

Nomenclature

Easy Selection

Selection/Dimensions



# SELECTION/DIMENSIONS



## MagnaGear G100 Hollow Bore Twin Tapered Bushing Information

Bore Dia.	Twin Tapered Bushing Kit Part Number	Twin Tapered Short Shaft Bushing Kit Part Number	"A"	"B"
3-7/16"	454062	272730	2.943"	7/8"
3-3/16"	454063	272731	2.768"	3/4"
3"	454064	272732	2.577"	3/4"
2-15/16"	454065	272733	2.514"	3/4"
2-7/8"	454066	272734	2.450"	3/4"
2-11/16"	454067	272735	2.338"	5/8"
2-1/2"	454068	272736	2.148"	5/8"
2-7/16"	454069	272737	2.443"	5/8"
2-3/8"	454070	272738	2.021"	5/8"
2-1/4"	454071	272739	1.972"	1/2"
2-3/16"	454072	272740	1.909"	1/2"
90mm	454078	272741	81mm	25mm
85mm	454073	272742	76mm	22mm
80mm	454074	272743	71mm	22mm
75mm	454075	272744	67.5mm	20mm
70mm	454079	272745	62.5mm	20mm
65mm	454076	272746	58mm	20mm
60mm	454077	272747	53mm	18mm

Features/Benefits

Specifications

Nomenclature

Easy Selection

Selection/Dimensions

## MagnaGear G150 Parallel Shaft Part Numbers

Nominal Ratio			Solid Shaft	Solid Shaft with Backstop	Hollow Shaft	Hollow Shaft with Backstop
D O U B L E	G150HP2	8.00	<b>449170</b>	<b>449182</b>	<b>449146</b>	<b>449158</b>
	G150HP2	9.00	<b>449171</b>	<b>449183</b>	<b>449147</b>	<b>449159</b>
	G150HP2	10.0	<b>449172</b>	<b>449184</b>	<b>449148</b>	<b>449160</b>
	G150HP2	11.2	<b>449173</b>	<b>449185</b>	<b>449149</b>	<b>449161</b>
	G150HP2	12.5	<b>449174</b>	<b>449186</b>	<b>449150</b>	<b>449162</b>
	G150HP2	14.0	<b>449175</b>	<b>449187</b>	<b>449151</b>	<b>449163</b>
	G150HP2	16.0	<b>449176</b>	<b>449188</b>	<b>449152</b>	<b>449164</b>
	G150HP2	18.0	<b>449177</b>	<b>449189</b>	<b>449153</b>	<b>449165</b>
	G150HP2	20.0	<b>449178</b>	<b>449190</b>	<b>449154</b>	<b>449166</b>
	G150HP2	22.4	<b>449179</b>	<b>449191</b>	<b>449155</b>	<b>449167</b>
T R I P L E	G150HP3	25.0	<b>449126</b>	<b>449135</b>	<b>449107</b>	<b>449117</b>
	G150HP3	28.0	<b>449127</b>	<b>449136</b>	<b>449108</b>	<b>449118</b>
	G150HP3	31.5	<b>449128</b>	<b>449137</b>	<b>449110</b>	<b>449119</b>
	G150HP3	35.5	<b>449129</b>	<b>449138</b>	<b>449111</b>	<b>449120</b>
	G150HP3	40.0	<b>449130</b>	<b>449139</b>	<b>449112</b>	<b>449121</b>
	G150HP3	45.0	<b>449131</b>	<b>449140</b>	<b>449113</b>	<b>449122</b>
	G150HP3	50.0	<b>449132</b>	<b>449141</b>	<b>449114</b>	<b>449123</b>
	G150HP3	56.0	<b>449133</b>	<b>449142</b>	<b>449115</b>	<b>449124</b>
	G150HP3	63.0	<b>449134</b>	<b>449143</b>	<b>449116</b>	<b>449125</b>

## MagnaGear G150 Right Angle Shaft Part Numbers

Nominal Ratio			Solid Shaft	Solid Shaft with Backstop	Hollow Shaft	Hollow Shaft with Backstop
T R I P L E	G150HR3	12.5	<b>449077</b>	<b>449092</b>	<b>449047</b>	<b>449062</b>
	G150HR3	14.0	<b>449078</b>	<b>449093</b>	<b>449048</b>	<b>449063</b>
	G150HR3	16.0	<b>449079</b>	<b>449094</b>	<b>449049</b>	<b>449064</b>
	G150HR3	18.0	<b>449080</b>	<b>449095</b>	<b>449050</b>	<b>449065</b>
	G150HR3	20.0	<b>449081</b>	<b>449096</b>	<b>449051</b>	<b>449066</b>
	G150HR3	22.4	<b>449082</b>	<b>449097</b>	<b>449052</b>	<b>449067</b>
	G150HR3	25.0	<b>449083</b>	<b>449098</b>	<b>449053</b>	<b>449068</b>
	G150HR3	28.0	<b>449084</b>	<b>449099</b>	<b>449054</b>	<b>449069</b>
	G150HR3	31.5	<b>449085</b>	<b>449100</b>	<b>449055</b>	<b>449070</b>
	G150HR3	35.5	<b>449086</b>	<b>449101</b>	<b>449056</b>	<b>449071</b>
	G150HR3	40.0	<b>449087</b>	<b>449102</b>	<b>449057</b>	<b>449072</b>
	G150HR3	45.0	<b>449088</b>	<b>449103</b>	<b>449058</b>	<b>449073</b>
	G150HR3	50.0	<b>449089</b>	<b>449104</b>	<b>449059</b>	<b>449074</b>
	G150HR3	56.0	<b>449090</b>	<b>449105</b>	<b>449060</b>	<b>449075</b>
G150HR3	63.0	<b>449091</b>	<b>449106</b>	<b>449061</b>	<b>449076</b>	

## G150 Accessory Part Numbers

### Shaft Driven Fan Kits

MagnaGear	Shaft Configuration	Reduction	Ratio	Part Number
G150HP2	Parallel	Double	8 - 22.4	<b>451010</b>
G150HP3	Parallel	Triple	25 - 63	<b>454009</b>
G150HR3	Right Angle	Triple	12.5 - 63	<b>454008</b>

Mechanical fan kit includes fan, fan shroud, fan guard and mounting hardware.

### Electric Fan Kits

MagnaGear	Shaft Configuration	Reduction	Ratio	Voltage	Phase	Part Number
All G150	All	All	All	230/460	3	<b>454047</b>
All G150	All	All	All	115	1	<b>454048</b>
All G150	All	All	All	230	1	<b>453933</b>
All G150	All	All	All	575	3	<b>454049</b>

Electrical fan kit includes fan, electric motor, fan shroud, fan guard and mounting hardware.

# SELECTION/DIMENSIONS



## MagnaGear G150 Parallel Shaft DOUBLE REDUCTION (8:1 TO 22.4:1) SOLID OUTPUT SHAFT

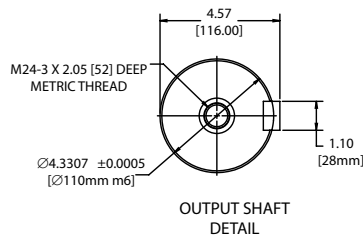
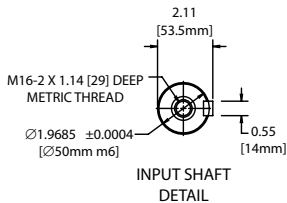
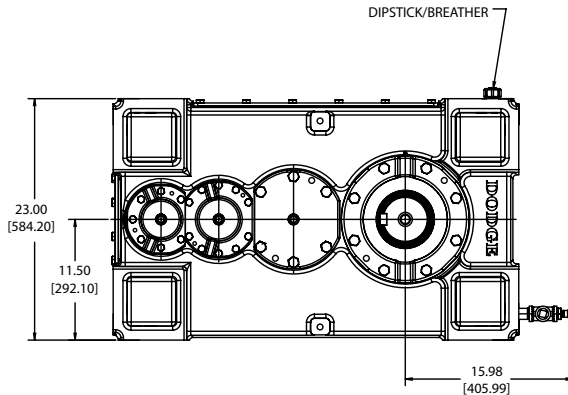
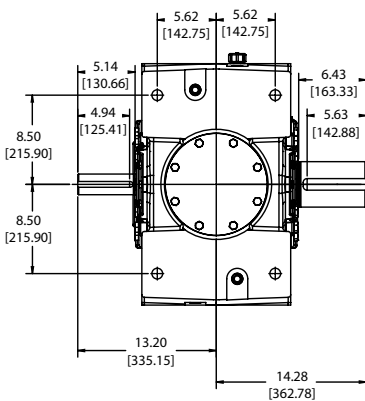
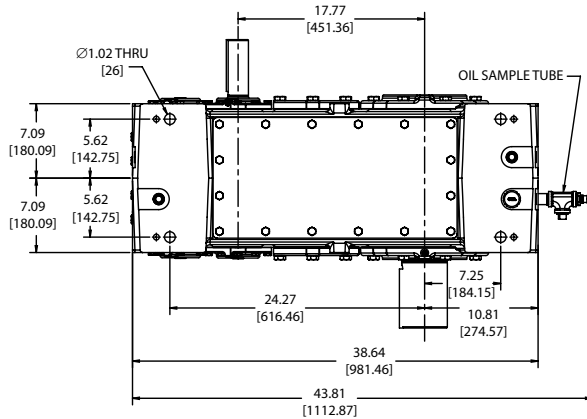
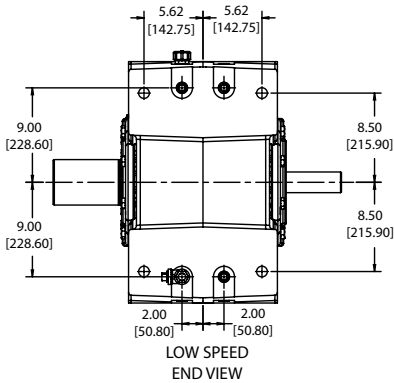

Weight without oil: 1619 lbs  
 Dimensions in [ ] are millimeters.  
 Drawing for reference only. Contact DODGE for certified drawing.

Features/Benefits

Specifications

Nomenclature

Easy Selection

Selection/Dimensions

# SELECTION/DIMENSIONS



## MagnaGear G150 Parallel Shaft TRIPLE REDUCTION (25:1 TO 63:1) SOLID OUTPUT SHAFT

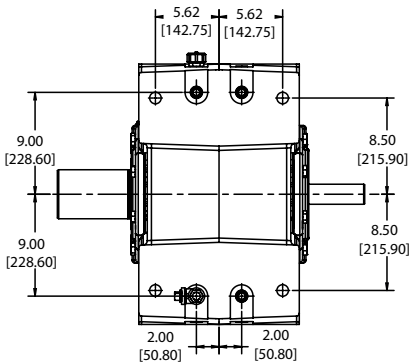

LOW SPEED  
END VIEW

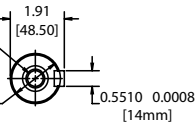
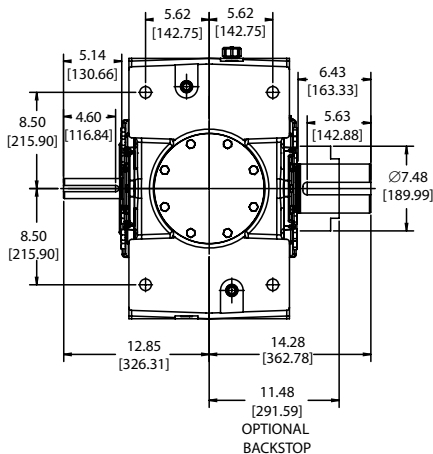
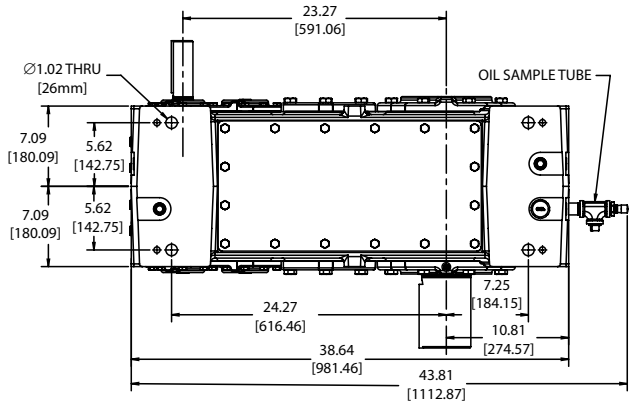

INPUT SHAFT  
DETAIL

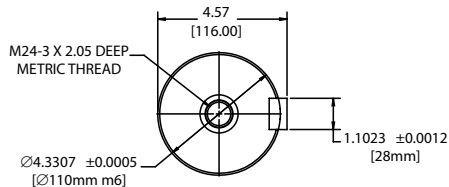
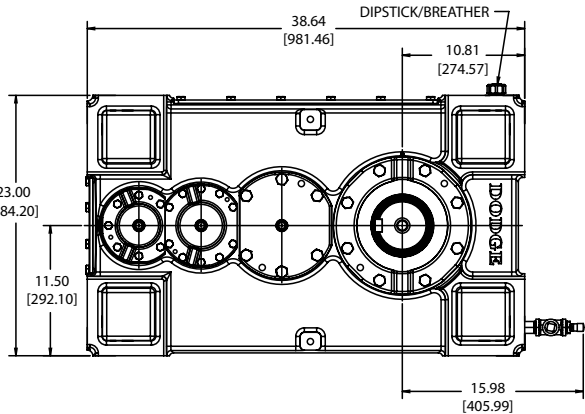

OUTPUT SHAFT  
DETAIL

Weight without oil: 1655 lbs  
Dimensions in [ ] are millimeters.  
Drawing for reference only. Contact DODGE for certified drawing.

# SELECTION/DIMENSIONS



## MagnaGear G150 Right Angle Shaft TRIPLE REDUCTION (12.5:1 TO 63:1) SOLID OUTPUT SHAFT

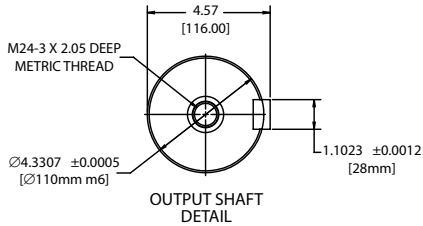
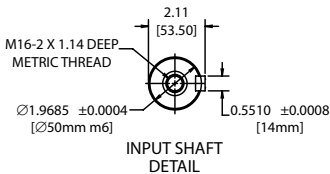
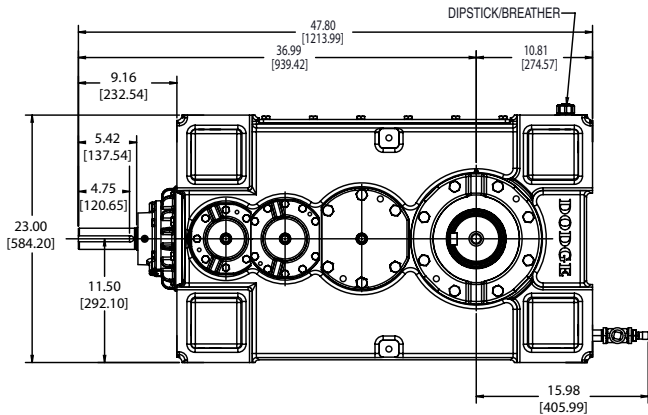
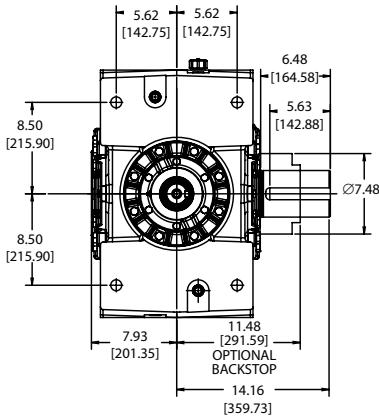
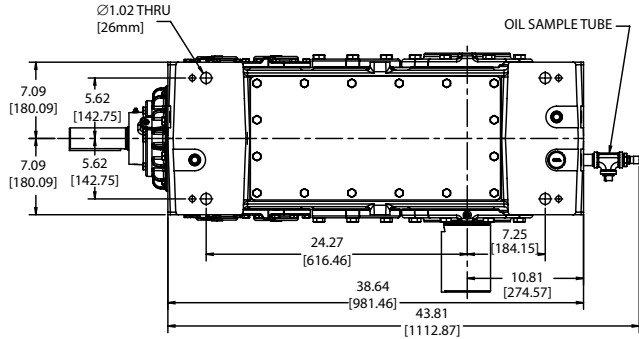
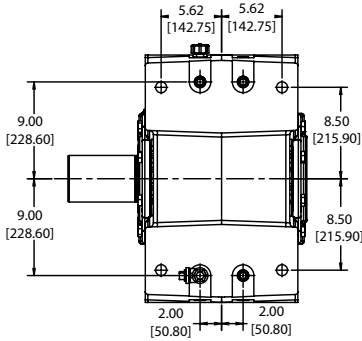

Weight without oil: 1714 lbs  
Dimensions in [ ] are millimeters.  
Drawing for reference only. Contact DODGE for certified drawing.

Features/Benefits

Specifications

Nomenclature

Easy Selection

Selection/Dimensions

# SELECTION/DIMENSIONS



## MagnaGear G150 Parallel Shaft DOUBLE REDUCTION (8:1 TO 22.4:1) HOLLOW OUTPUT SHAFT

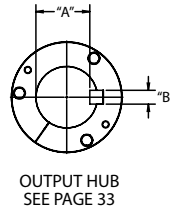
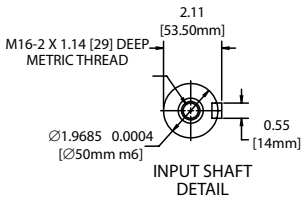
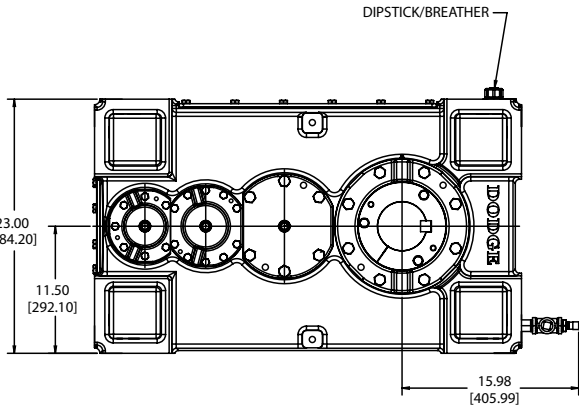
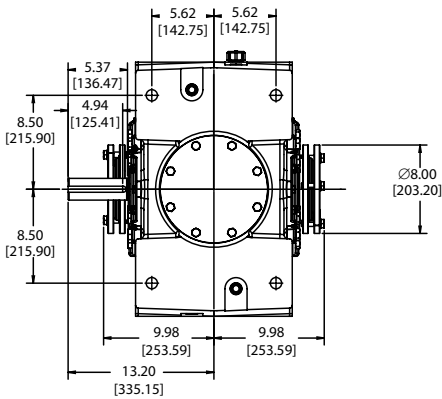
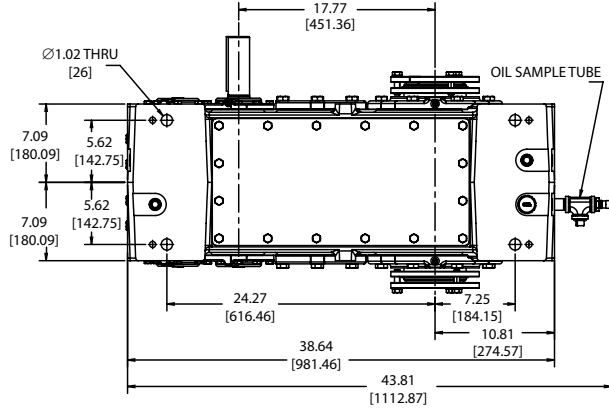
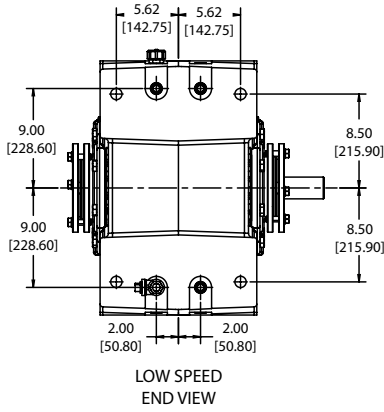

Weight without oil: 1556 lbs  
 Dimensions in [ ] are millimeters.  
 Drawing for reference only. Contact DODGE for certified drawing.

# SELECTION/DIMENSIONS



## MagnaGear G150 Parallel Shaft TRIPLE REDUCTION (25:1 TO 63:1) HOLLOW OUTPUT SHAFT

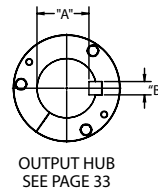
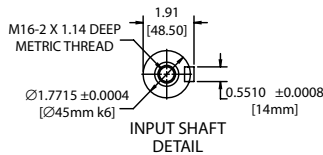
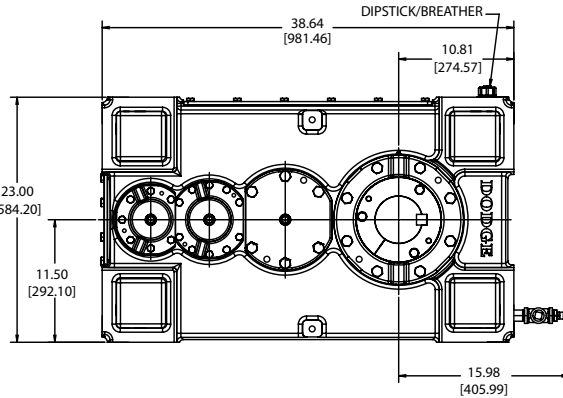
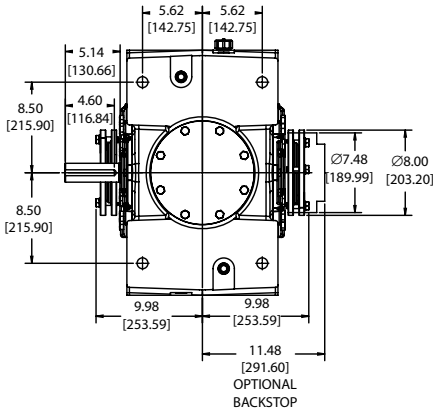
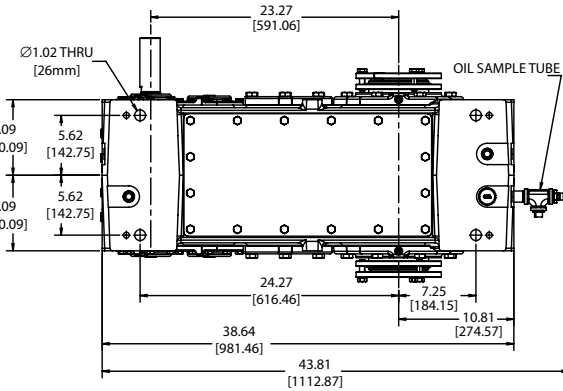
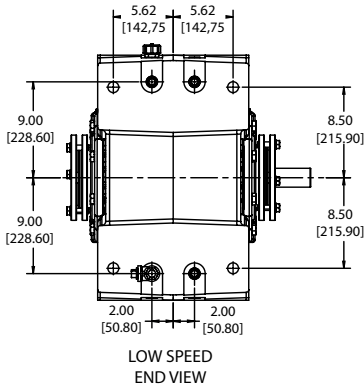

Weight without oil: 1593 lbs  
Dimensions in [ ] are millimeters.  
Drawing for reference only. Contact DODGE for certified drawing.



# SELECTION/DIMENSIONS



## MagnaGear G150 Right Angle Shaft TRIPLE REDUCTION (12.5:1 TO 63:1) HOLLOW OUTPUT SHAFT

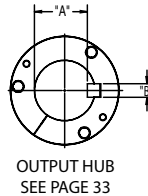
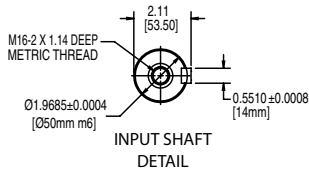
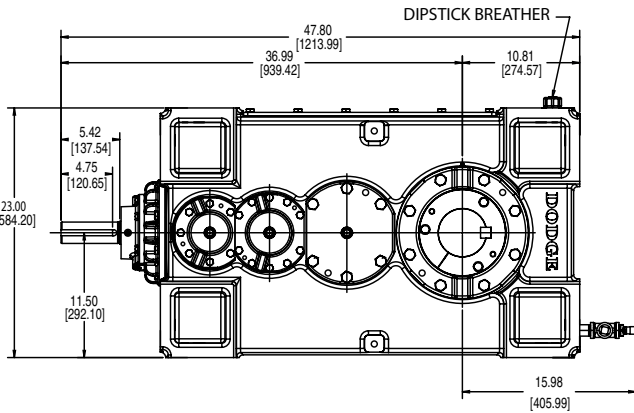
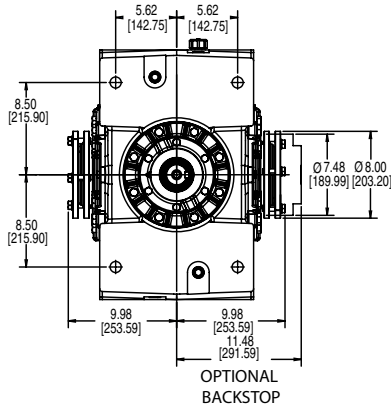
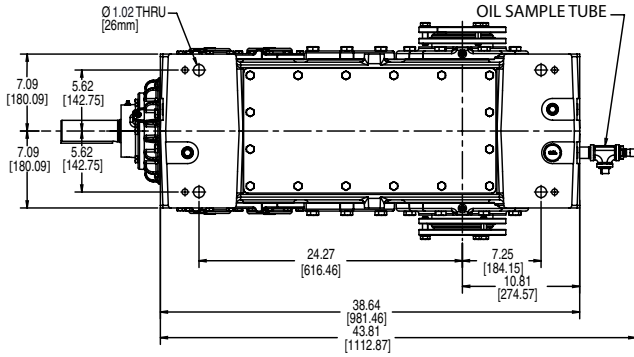
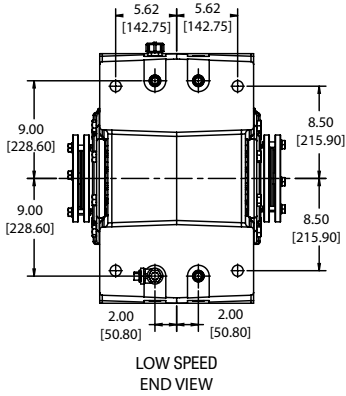

Weight without oil: 1651 lbs  
Dimensions in [ ] are millimeters.  
Drawing for reference only. Contact DODGE for certified drawing.

## MagnaGear G150 Hollow Bore Twin Tapered Bushing Information

Bore Dia.	Twin Tapered Bushing Kit Part Number	Twin Tapered Short Shaft Bushing Kit Part Number	"A"	"B"
4-7/16"	454081	272750	3.880"	1"
4-3/16"	454082	272751	3.627"	1"
3-15/16"	454083	272752	3.373"	1"
3-7/16"	454084	272753	2.943"	7/8"
3-3/16"	454085	272754	2.768"	3/4"
3"	454086	272755	2.577"	3/4"
2-15/16"	454087	272756	2.514"	3/4"
120mm	454088	272757	109mm	32mm
110mm	454089	272758	100mm	28mm
100mm	454090	272759	90mm	28mm
95mm	454091	272760	86mm	25mm
90mm	454092	272761	81mm	25mm
85mm	454093	272762	76mm	22mm
80mm	454094	272763	71mm	22mm
75mm	454095	272764	67.5mm	20mm

## SELECTION/DIMENSIONS



## MagnaGear G210 Parallel Shaft Part Numbers

Nominal Ratio			Solid Shaft	Solid Shaft with Backstop	Hollow Shaft	Hollow Shaft with Backstop
D O U B L E	G210HP2	8.00	449317	449329	449292	449305
	G210HP2	9.00	449318	449330	449293	449306
	G210HP2	10.0	449319	449331	449294	449307
	G210HP2	11.2	449320	449332	449295	449308
	G210HP2	12.5	449321	449333	449296	449309
	G210HP2	14.0	449322	449334	449297	449310
	G210HP2	16.0	449323	449335	449298	449311
	G210HP2	18.0	449324	449336	449299	449312
	G210HP2	20.0	449325	449337	449300	449313
	G210HP2	22.4	449326	449338	449301	449314
T R I P L E	G210HP3	25.0	449272	449281	449253	449262
	G210HP3	28.0	449273	449282	449254	449263
	G210HP3	31.5	449274	449283	449255	449264
	G210HP3	35.5	449275	449284	449256	449265
	G210HP3	40.0	449276	449285	449257	449267
	G210HP3	45.0	449277	449286	449258	449268
	G210HP3	50.0	449278	449287	449259	449269
	G210HP3	56.0	449279	449288	449260	449270
	G210HP3	63.0	449280	449289	449261	449271

## MagnaGear G210 Right Angle Shaft Part Numbers

Nominal Ratio			Solid Shaft	Solid Shaft with Backstop	Hollow Shaft	Hollow Shaft with Backstop
T R I P L E	G210HR3	12.5	449222	449237	449192	449207
	G210HR3	14.0	449223	449238	449193	449208
	G210HR3	16.0	449224	449240	449194	449209
	G210HR3	18.0	449225	449241	449195	449210
	G210HR3	20.0	449226	449242	449196	449211
	G210HR3	22.4	449227	449243	449197	449212
	G210HR3	25.0	449228	449244	449198	449213
	G210HR3	28.0	449229	449245	449199	449214
	G210HR3	31.5	449230	449246	449200	449215
	G210HR3	35.5	449231	449247	449201	449216
	G210HR3	40.0	449232	449248	449202	449217
	G210HR3	45.0	449233	449249	449203	449218
	G210HR3	50.0	449234	449250	449204	449219
	G210HR3	56.0	449235	449251	449205	449220
G210HR3	63.0	449236	449252	449206	449221	

## G210 Accessory Part Numbers

### Shaft Driven Fan Kits

MagnaGear	Shaft Configuration	Reduction	Ratio	Part Number
G210HP2	Parallel	Double	8 - 22.4	<b>454013</b>
G210HP3	Parallel	Triple	25 - 63	<b>454012</b>
G210HR3	Right Angle	Triple	12.5 - 63	<b>454011</b>

Mechanical fan kit includes fan, fan shroud, fan guard and mounting hardware.

### Electric Fan Kits

MagnaGear	Shaft Configuration	Reduction	Ratio	Voltage	Phase	Part Number
All G210	All	All	All	230/460	3	<b>454044</b>
All G210	All	All	All	115	1	<b>454045</b>
All G210	All	All	All	230	1	<b>454033</b>
All G210	All	All	All	575	3	<b>454046</b>

Electrical fan kit includes fan, electric motor, fan shroud, fan guard and mounting hardware.

# SELECTION/DIMENSIONS



## MagnaGear G210 Parallel Shaft DOUBLE REDUCTION (8:1 TO 22.4:1) SOLID OUTPUT SHAFT

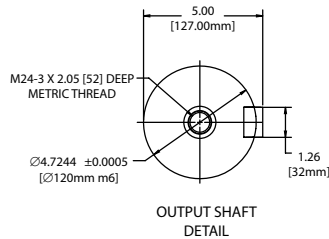
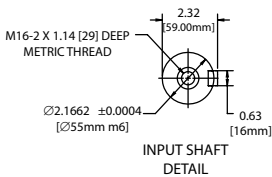
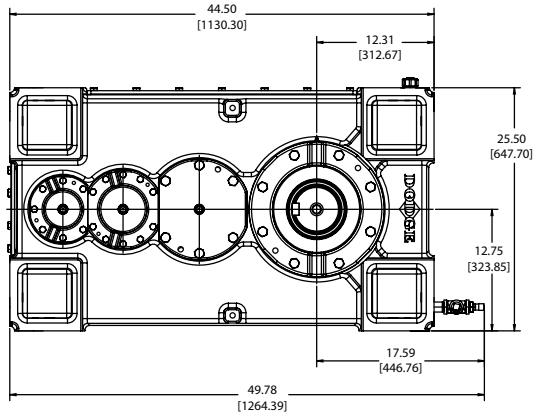
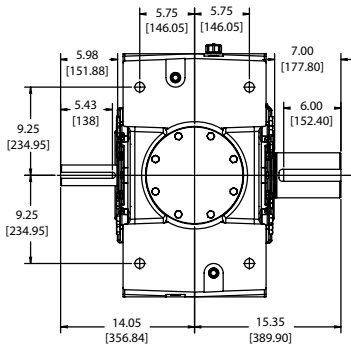
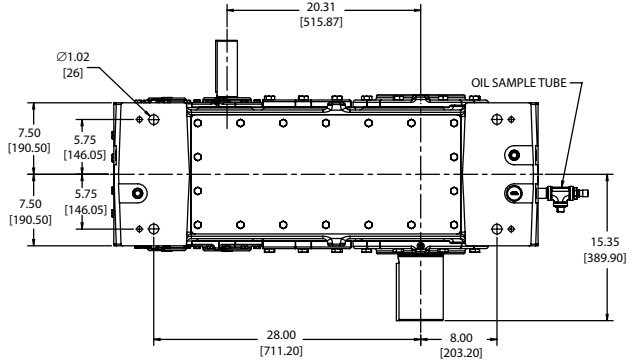
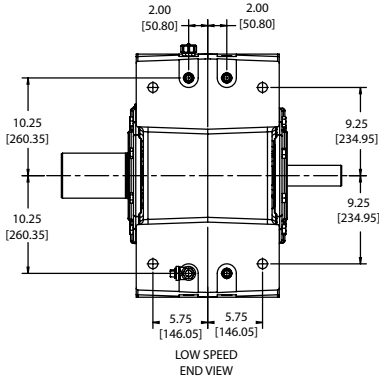

Weight without oil: 2134 lbs  
 Dimensions in [ ] are millimeters.  
 Drawing for reference only. Contact DODGE for certified drawing.

# SELECTION/DIMENSIONS



## MagnaGear G210 Parallel Shaft TRIPLE REDUCTION (25:1 TO 63:1) SOLID OUTPUT SHAFT

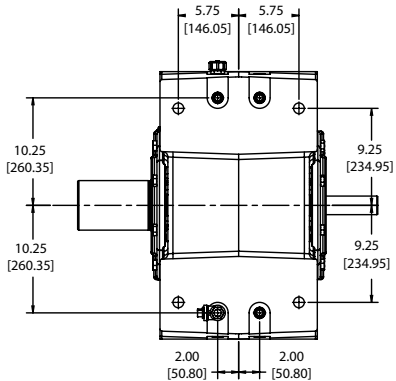

LOW SPEED  
END VIEW

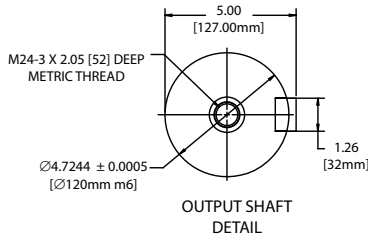
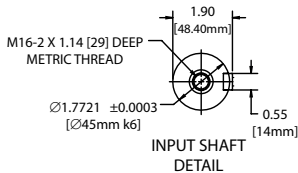
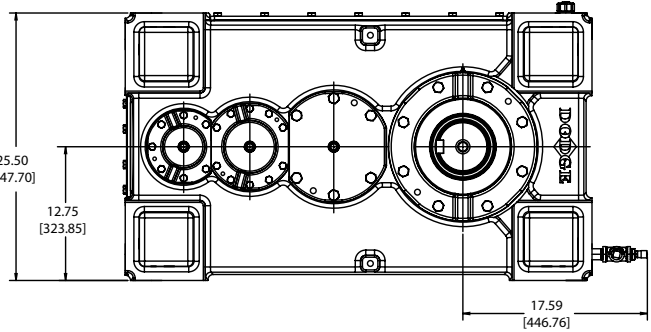
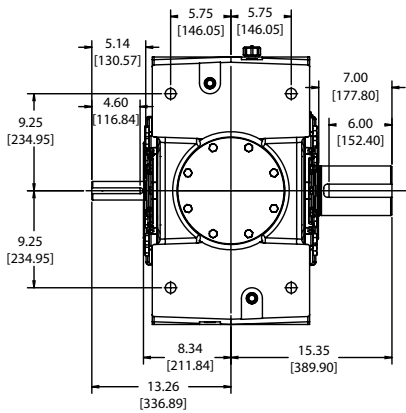
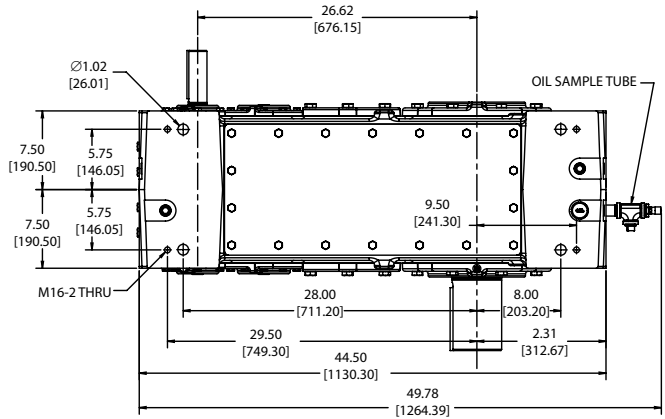

Weight without oil: 2187 lbs  
Dimensions in [ ] are millimeters.  
Drawing for reference only. Contact DODGE for certified drawing.

Features/Benefits

Specifications

Nomenclature

Easy Selection

Selection/Dimensions

# SELECTION/DIMENSIONS



## MagnaGear G210 Right Angle Shaft TRIPLE REDUCTION (12.5:1 TO 63:1) SOLID OUTPUT SHAFT

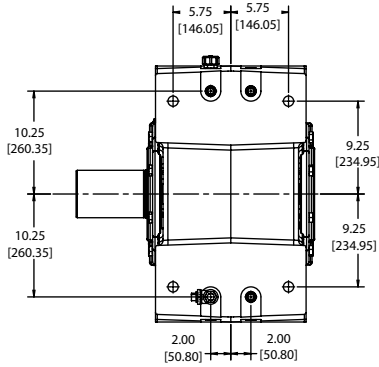

LOW SPEED  
END VIEW

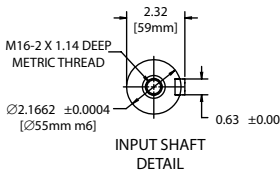
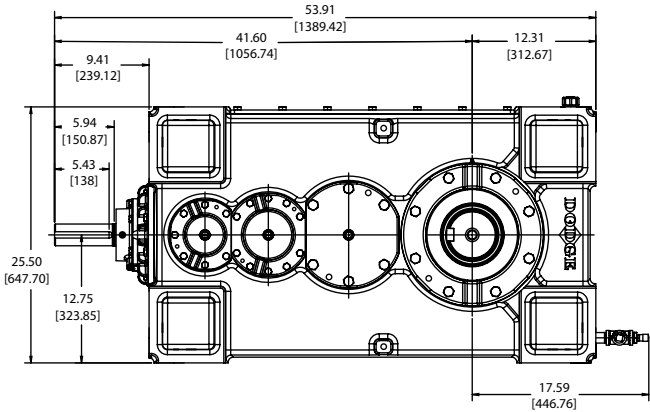
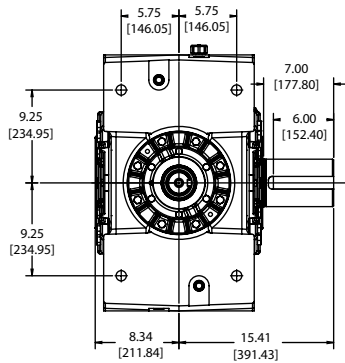
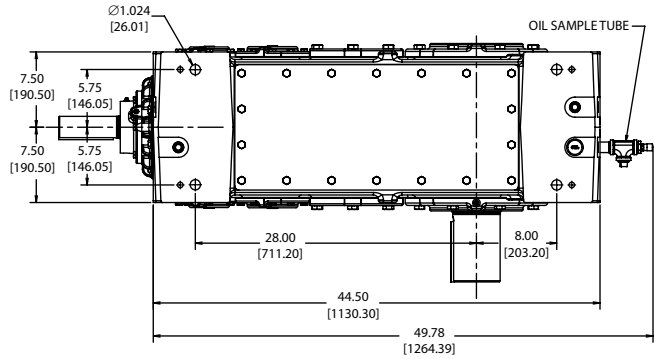

INPUT SHAFT  
DETAIL

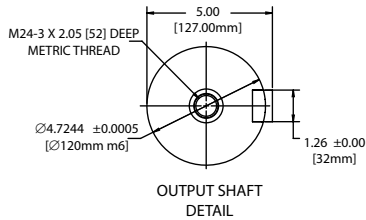

OUTPUT SHAFT  
DETAIL

Weight without oil: 2253 lbs  
Dimensions in [ ] are millimeters.  
Drawing for reference only. Contact DODGE for certified drawing.

# SELECTION/DIMENSIONS



## MagnaGear G210 Parallel Shaft DOUBLE REDUCTION (8:1 TO 22.4:1) HOLLOW OUTPUT SHAFT

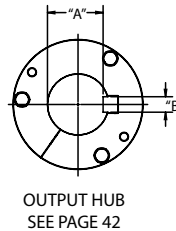
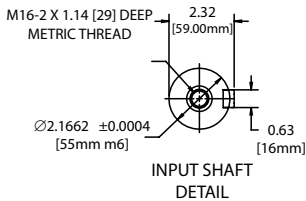
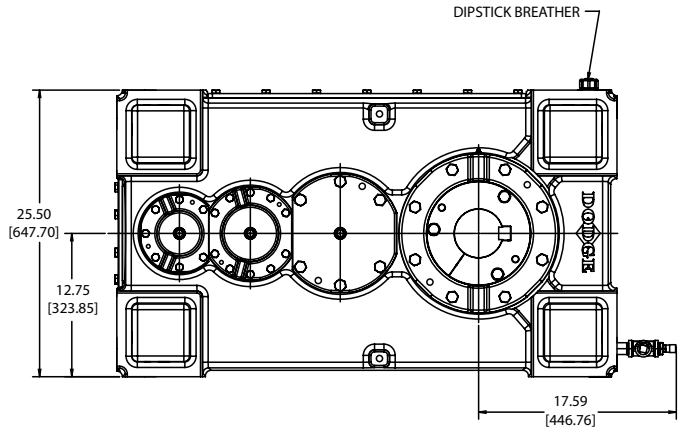
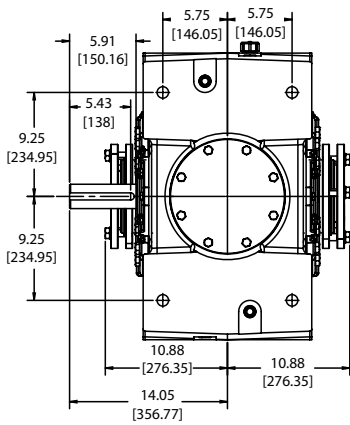
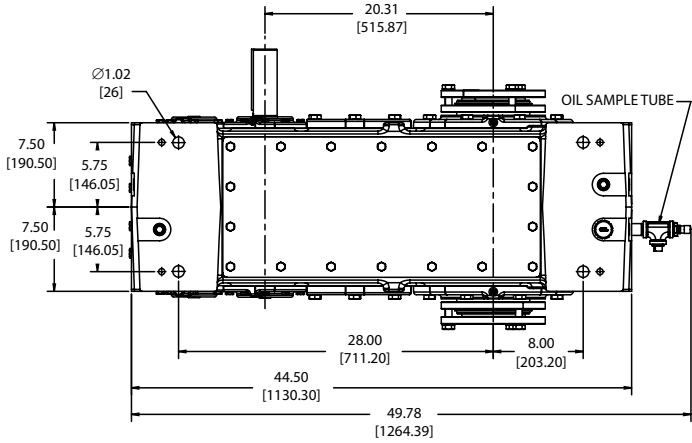
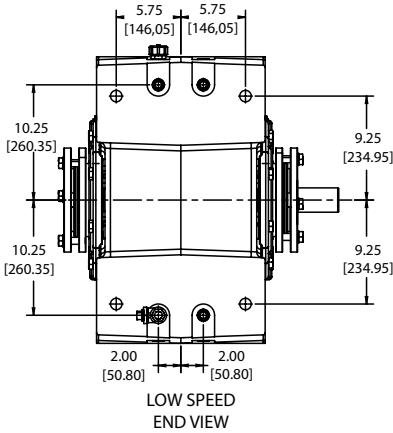

Weight without oil: 2057 lbs  
Dimensions in [ ] are millimeters.  
Drawing for reference only. Contact DODGE for certified drawing.

Features/Benefits

Specifications

Nomenclature

Easy Selection

Selection/Dimensions



# SELECTION/DIMENSIONS



## MagnaGear G210 Parallel Shaft TRIPLE REDUCTION (25:1 TO 63:1) HOLLOW OUTPUT SHAFT

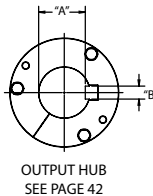
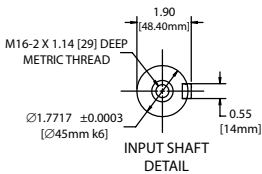
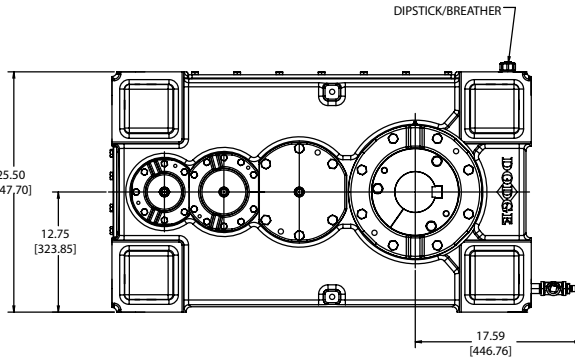
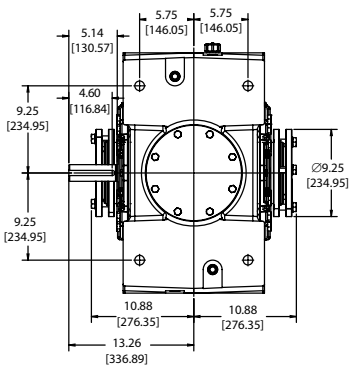
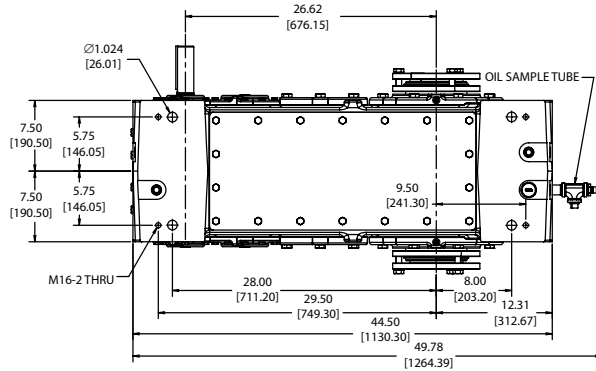
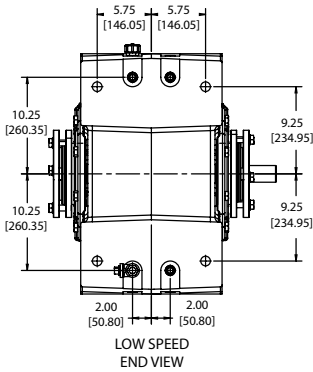

Weight without oil: 2111 lbs  
 Dimensions in [ ] are millimeters.  
 Drawing for reference only. Contact DODGE for certified drawing.

## MagnaGear G210 Right Angle Shaft TRIPLE REDUCTION (12.5:1 to 63:1) HOLLOW OUTPUT SHAFT

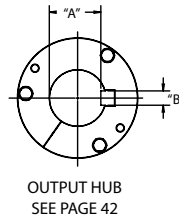
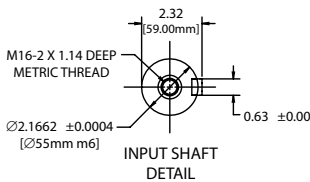
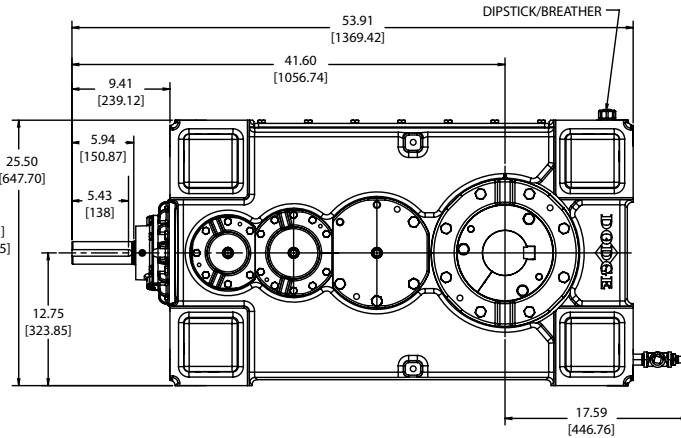
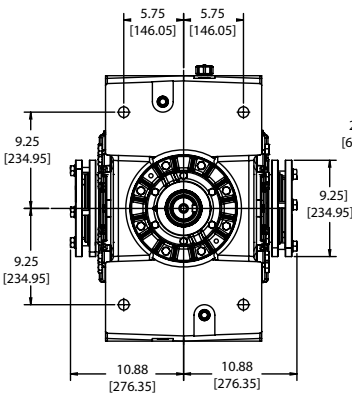
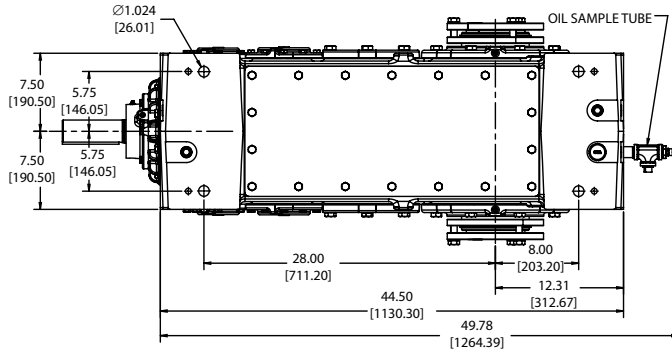
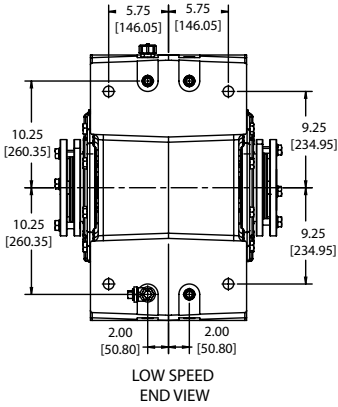

Weight without oil: 2175 lbs  
Dimensions in [ ] are millimeters.  
Drawing for reference only. Contact DODGE for certified drawing.

# SELECTION/DIMENSIONS



## MagnaGear G210 Hollow Bore Twin Tapered Bushing Information

Bore Dia.	Twin Tapered Bushing Kit Part Number	Twin Tapered Short Shaft Bushing Kit Part Number	"A"	"B"
4-15/16"	454099	272767	4.232"	1-1/4"
4-7/16"	454100	272768	3.880"	1"
4-3/16"	454101	272769	3.627"	1"
3-15/16"	454102	272770	3.373"	1"
3-7/16"	454103	272771	2.943"	7/8"
130mm	454104	272772	118mm	40mm
125mm	454105	272773	114mm	32mm
120mm	454106	272774	109mm	32mm
110mm	454107	272775	100mm	28mm
100mm	454108	272776	90mm	28mm
95mm	454109	272777	86mm	25mm
90mm	454110	272778	81mm	25mm

Features/Benefits

Specifications

Nomenclature

Easy Selection

Selection/Dimensions

## MagnaGear G285 Parallel Shaft Part Numbers

Nominal Ratio			Solid Shaft	Solid Shaft with Backstop	Hollow Shaft	Hollow Shaft with Backstop
D O U B L E	G285HP2	8.0	449461	449473	449437	449449
	G285HP2	9.0	449462	449474	449438	449450
	G285HP2	10.0	449463	449475	449439	449451
	G285HP2	11.2	449464	449476	449440	449452
	G285HP2	12.5	449465	449477	449441	449453
	G285HP2	14.0	449466	449478	449442	449454
	G285HP2	16.0	449467	449479	449443	449455
	G285HP2	18.0	449468	449480	449444	449456
	G285HP2	20.0	449469	449481	449445	449457
	G285HP2	22.4	449470	449482	449446	449458
T R I P L E	G285HP3	25.0	449417	449426	449399	449408
	G285HP3	28.0	449418	449427	449400	449409
	G285HP3	31.5	449419	449428	449401	449410
	G285HP3	35.5	449420	449429	449402	449411
	G285HP3	40.0	449421	449430	449403	449412
	G285HP3	45.0	449422	449431	449404	449413
	G285HP3	50.0	449423	449432	449405	449414
	G285HP3	56.0	449424	449433	449406	449415
G285HP3	63.0	449425	449434	449407	449416	

## MagnaGear G285 Right Angle Shaft Part Numbers

Nominal Ratio			Solid Shaft	Solid Shaft with Backstop	Hollow Shaft	Hollow Shaft with Backstop
T R I P L E	G285HR3	12.5	449339	449384	449369	449354
	G285HR3	14.0	449340	449385	449370	449355
	G285HR3	16.0	449341	449386	449371	449356
	G285HR3	18.0	449342	449387	449372	449357
	G285HR3	20.0	449343	449388	449373	449358
	G285HR3	22.4	449344	449389	449374	449359
	G285HR3	25.0	449345	449390	449375	449360
	G285HR3	28.0	449346	449391	449376	449361
	G285HR3	31.5	449347	449392	449377	449362
	G285HR3	35.5	449348	449393	449378	449363
	G285HR3	40.0	449349	449394	449379	449364
	G285HR3	45.0	449350	449395	449380	449365
	G285HR3	50.0	449351	449396	449381	449366
	G285HR3	56.0	449352	449397	449382	449367
	G285HR3	63.0	449353	449398	449383	449368

## G285 Accessory Part Numbers

### Shaft Driven Fan Kits

MagnaGear	Shaft Configuration	Reduction	Ratio	Part Number
G285HP2	Parallel	Double	8 - 22.4	<b>454015</b>
G285HP3	Parallel	Triple	25 - 63	<b>454014</b>
G285HR3	Right Angle	Triple	12.5 - 63	<b>451526</b>

Mechanical fan kit includes fan, fan shroud, fan guard and mounting hardware.

### Electric Fan Kits

MagnaGear	Shaft Configuration	Reduction	Ratio	Voltage	Phase	Part Number
All G285	All	All	All	230/460	3	<b>454023</b>
All G285	All	All	All	115	1	<b>454024</b>
All G285	All	All	All	230	1	<b>454198</b>
All G285	All	All	All	575	3	<b>454025</b>

Electrical fan kit includes fan, electric motor, fan shroud, fan guard and mounting hardware.

# SELECTION/DIMENSIONS



## MagnaGear G285 Parallel Shaft DOUBLE REDUCTION (8:1 TO 22.4:1) SOLID OUTPUT SHAFT

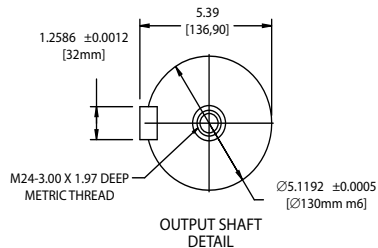
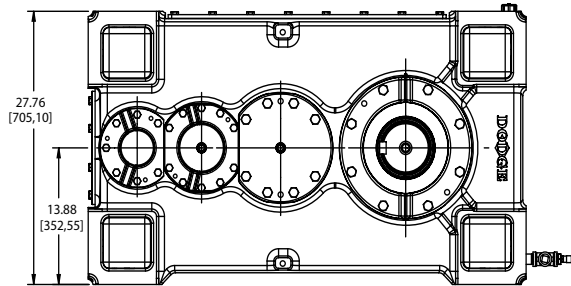
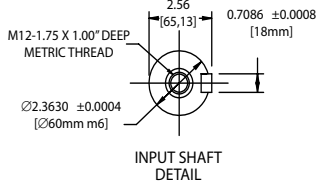
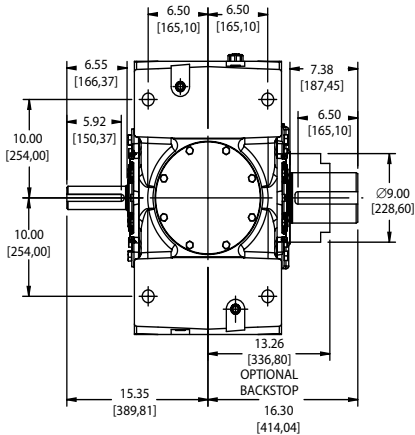
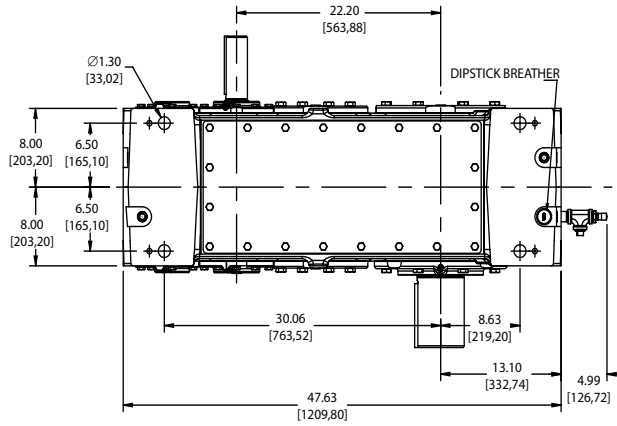
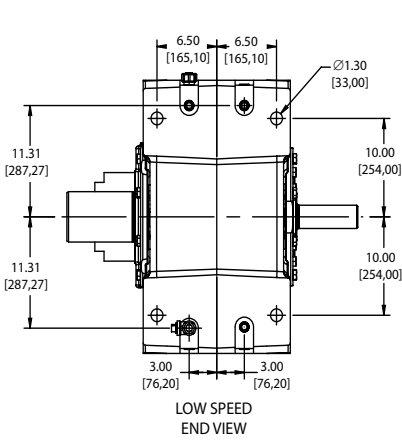

Weight without oil: 2379 lbs  
 Dimensions in [ ] are millimeters.  
 Drawing for reference only. Contact DODGE for certified drawing.

# SELECTION/DIMENSIONS



## MagnaGear G285 Parallel Shaft TRIPLE REDUCTION (25:1 TO 63:1) SOLID OUTPUT SHAFT

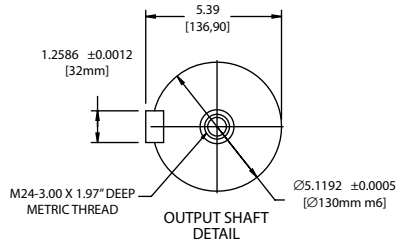
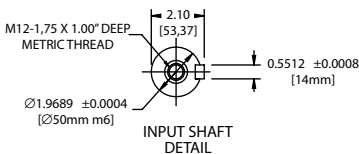
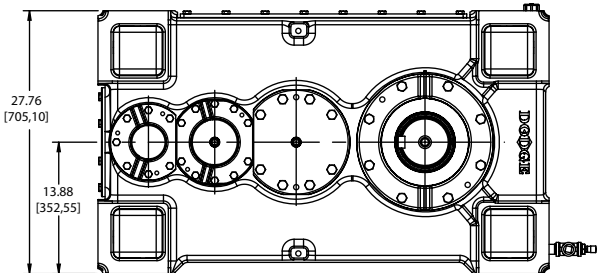
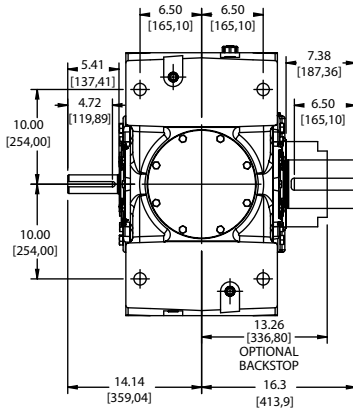
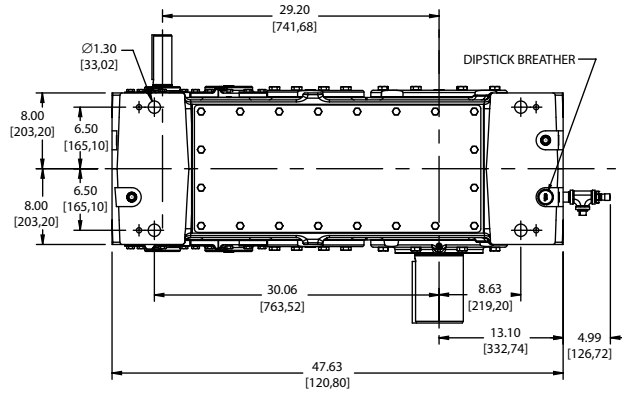
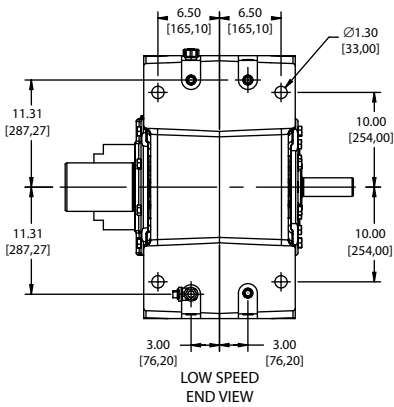

Weight without oil: 2450 lbs  
 Dimensions in [ ] are millimeters.  
 Drawing for reference only. Contact DODGE for certified drawing.





# SELECTION/DIMENSIONS



## MagnaGear G285 Parallel Shaft DOUBLE REDUCTION (8:1 TO 22.4:1) HOLLOW OUTPUT SHAFT

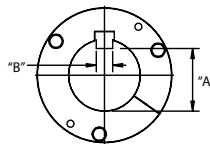
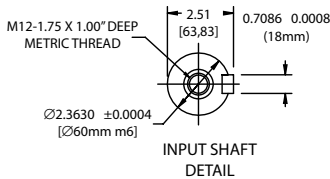
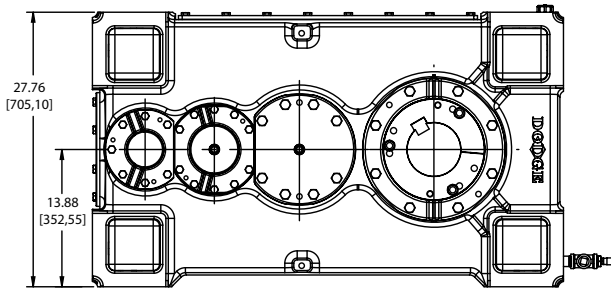
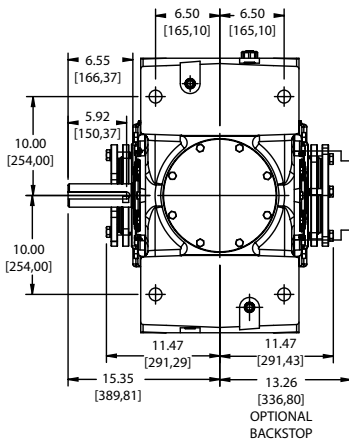
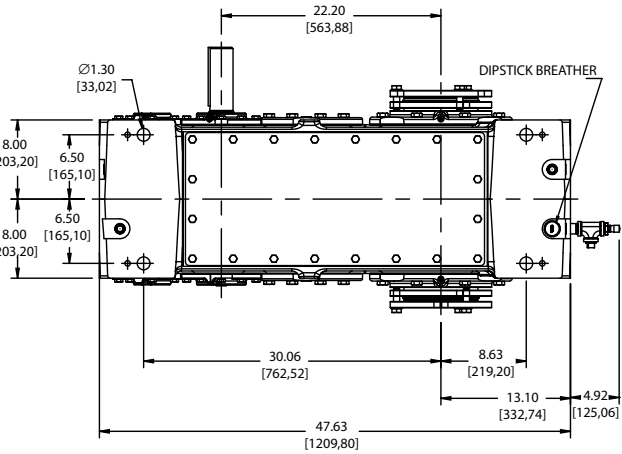
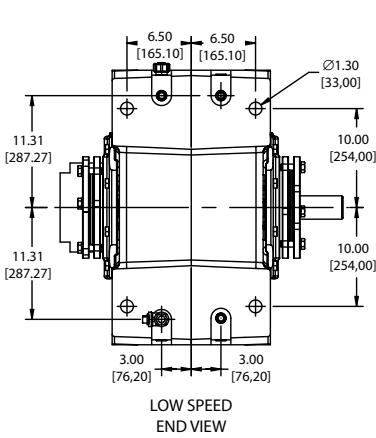

Weight without oil: 2256 lbs  
 Dimensions in [ ] are millimeters.  
 Drawing for reference only. Contact DODGE for certified drawing.

# SELECTION/DIMENSIONS



## MagnaGear G285 Parallel Shaft TRIPLE REDUCTION (25:1 TO 63:1) HOLLOW OUTPUT SHAFT

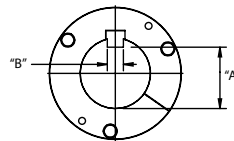
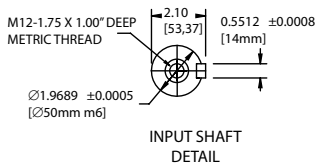
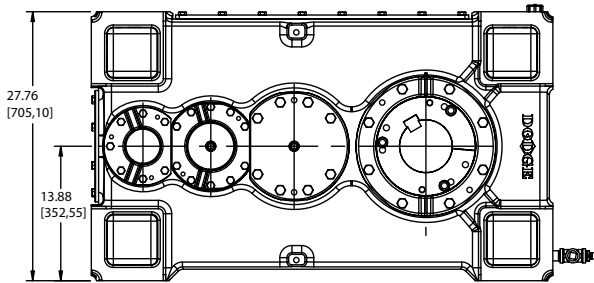
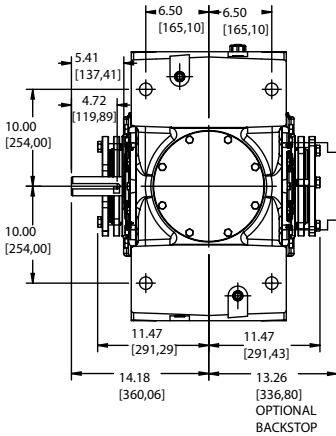
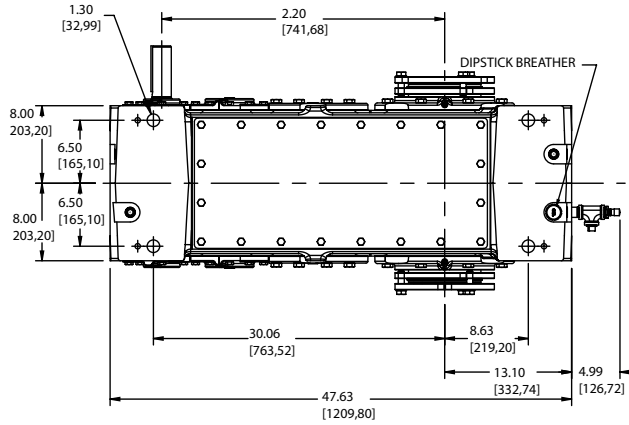
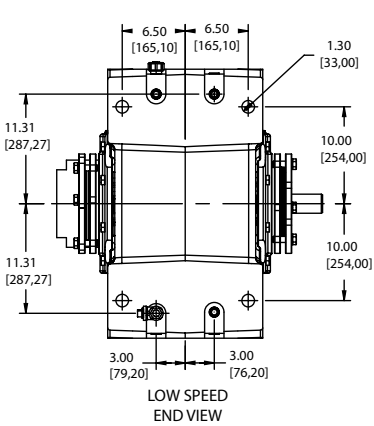

Weight without oil: 2319 lbs  
Dimensions in [ ] are millimeters.  
Drawing for reference only. Contact DODGE for certified drawing.

# SELECTION/DIMENSIONS



## MagnaGear G285 Right Angle Shaft TRIPLE REDUCTION (12.5:1 TO 63:1) HOLLOW OUTPUT SHAFT

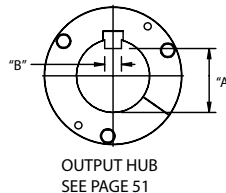
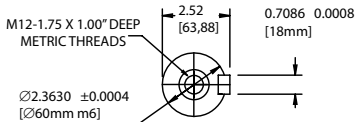
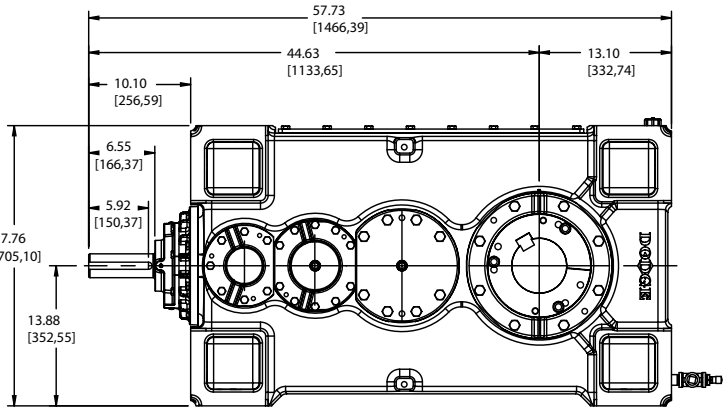
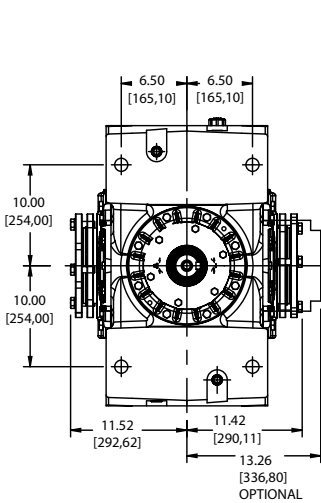
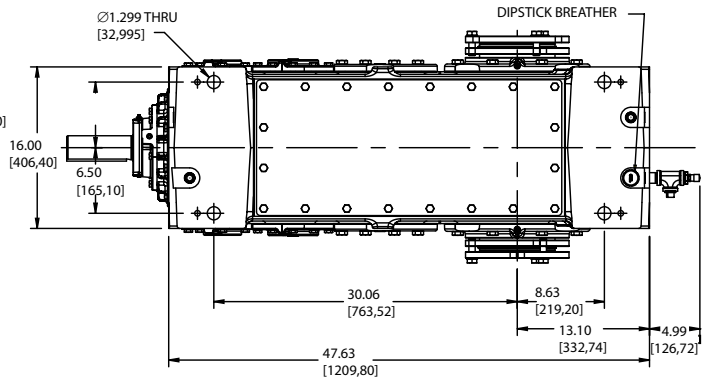
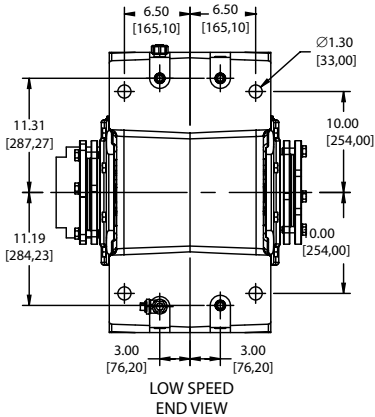

Weight without oil: 2413 lbs  
 Dimensions in [ ] are millimeters.  
 Drawing for reference only. Contact DODGE for certified drawing.

## MagnaGear G285 Hollow Bore Twin Tapered Bushing Information

Bore Dia.	Twin Tapered Bushing Kit Part Number	Twin Tapered Short Shaft Bushing Kit Part Number	"A"	"B"
6"	454114	272780	5.155"	1-1/2"
5-15/16"	454115	272781	5.091"	1-1/2"
5-7/16"	454116	272782	4.740"	1-1/4"
4-15/16"	454117	272783	4.232"	1-1/4"
4-7/16"	454118	272784	3.880"	1"
4-3/16"	454119	272785	3.627"	1"
3-15/16"	454120	272786	3.373"	1"
150mm	454121	272787	138mm	36mm
130mm	454122	272788	119mm	32mm
125mm	454123	272789	114mm	32mm
120mm	454124	272790	109mm	32mm
110mm	454125	272791	100mm	28mm
100mm	454126	272792	90mm	28mm

## SELECTION/DIMENSIONS



## MagnaGear G390 Parallel Shaft Part Numbers

Nominal Ratio			Solid Shaft	Solid Shaft with Backstop	Hollow Shaft	Hollow Shaft with Backstop
D O U B L E	G390HP2	8.00	449607	449619	449583	449595
	G390HP2	9.00	449608	449620	449584	449596
	G390HP2	10.0	449609	449621	449585	449597
	G390HP2	11.2	449610	449622	449586	449598
	G390HP2	12.5	449611	449623	449587	449599
	G390HP2	14.0	449612	449624	449588	449600
	G390HP2	16.0	449613	449625	449589	449601
	G390HP2	18.0	449614	449626	449590	449602
	G390HP2	20.0	449615	449627	449591	449603
	G390HP2	22.4	449616	449628	449592	449604
T R I P L E	G390HP3	25.0	449563	449572	449545	449554
	G390HP3	28.0	449564	449573	449546	449555
	G390HP3	31.5	449565	449574	449547	449556
	G390HP3	35.5	449566	449575	449548	449557
	G390HP3	40.0	449567	449576	449549	449558
	G390HP3	45.0	449568	449577	449550	449559
	G390HP3	50.0	449569	449578	449551	449560
	G390HP3	56.0	449570	449579	449552	449561
	G390HP3	63.0	449571	449580	449553	449562

## MagnaGear G390 Right Angle Shaft Part Numbers

Nominal Ratio			Solid Shaft	Solid Shaft with Backstop	Hollow Shaft	Hollow Shaft with Backstop
T R I P L E	G390HR3	12.5	449515	449530	449483	449498
	G390HR3	14.0	449516	449531	449484	449499
	G390HR3	16.0	449517	449532	449485	449500
	G390HR3	18.0	449518	449533	449486	449501
	G390HR3	20.0	449519	449534	449487	449502
	G390HR3	22.4	449520	449535	449488	449504
	G390HR3	25.0	449521	449536	449489	449506
	G390HR3	28.0	449522	449537	449490	449507
	G390HR3	31.5	449523	449538	449491	449508
	G390HR3	35.5	449524	449539	449492	449509
	G390HR3	40.0	449525	449540	449493	449510
	G390HR3	45.0	449526	449541	449494	449511
	G390HR3	50.0	449527	449542	449495	449512
	G390HR3	56.0	449528	449543	449496	449513
G390HR3	63.0	449529	449544	449497	449514	

## G390 Accessory Part Numbers

### Shaft Driven Fan Kits

MagnaGear	Shaft Configuration	Reduction	Ratio	Part Number
G390HP2	Parallel	Double	8 - 22.4	<b>454018</b>
G390HP3	Parallel	Triple	25 - 63	<b>454017</b>
G390HR3	Right Angle	Triple	12.5 - 63	<b>454016</b>

Mechanical fan kit includes fan, fan shroud, fan guard and mounting hardware.

### Electric Fan Kits

MagnaGear	Shaft Configuration	Reduction	Ratio	Voltage	Phase	Part Number
All G390	All	All	All	230/460	3	<b>454026</b>
All G390	All	All	All	115	1	<b>454027</b>
All G390	All	All	All	230	1	<b>454199</b>
All G390	All	All	All	575	3	<b>454028</b>

Electrical fan kit includes fan, electric motor, fan shroud, fan guard and mounting hardware.

# SELECTION/DIMENSIONS



## MagnaGear G390 Parallel Shaft DOUBLE REDUCTION (8:1 TO 22.4:1) SOLID OUTPUT SHAFT

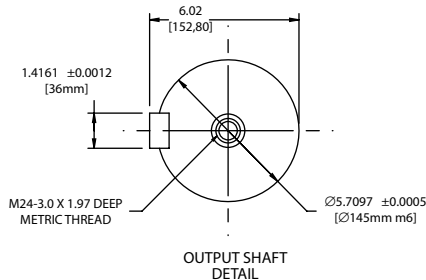
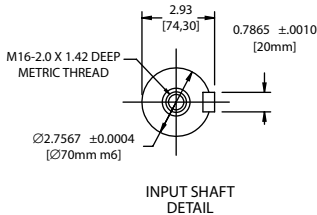
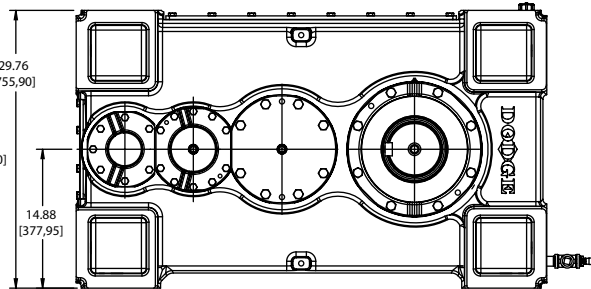
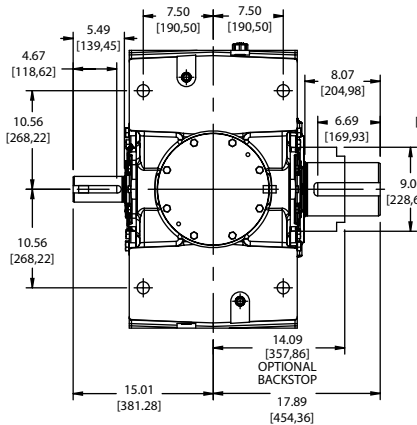
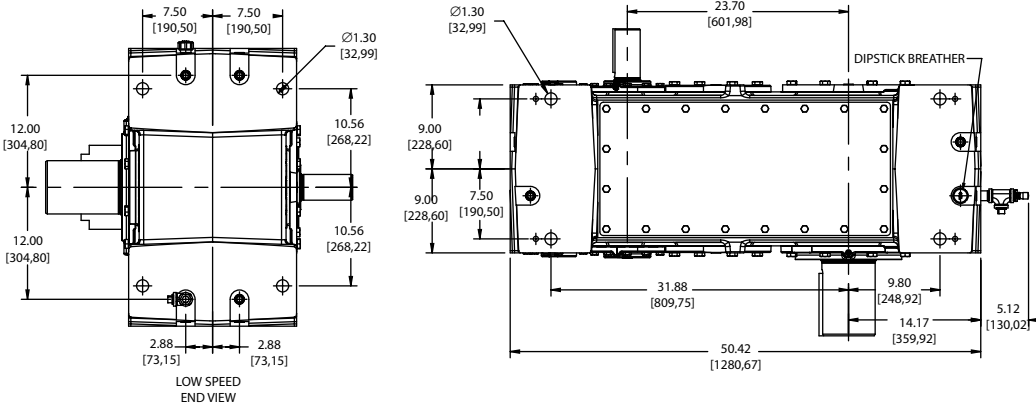

Weight without oil: 3215 lbs  
 Dimensions in [ ] are millimeters.  
 Drawing for reference only. Contact DODGE for certified drawing.

# SELECTION/DIMENSIONS



## MagnaGear G390 Parallel Shaft TRIPLE REDUCTION (25:1 TO 63:1) SOLID OUTPUT SHAFT

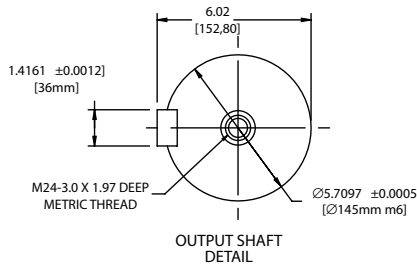
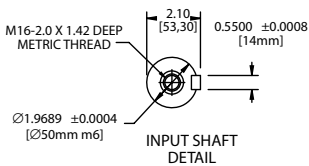
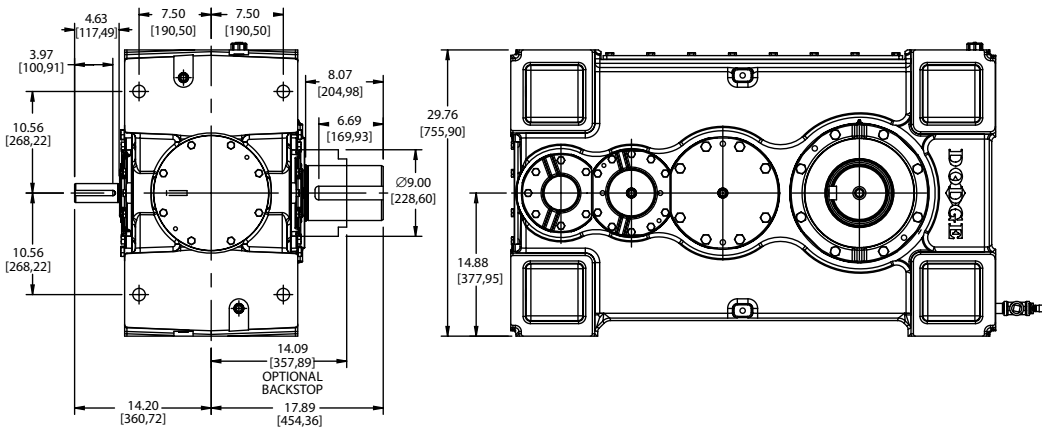
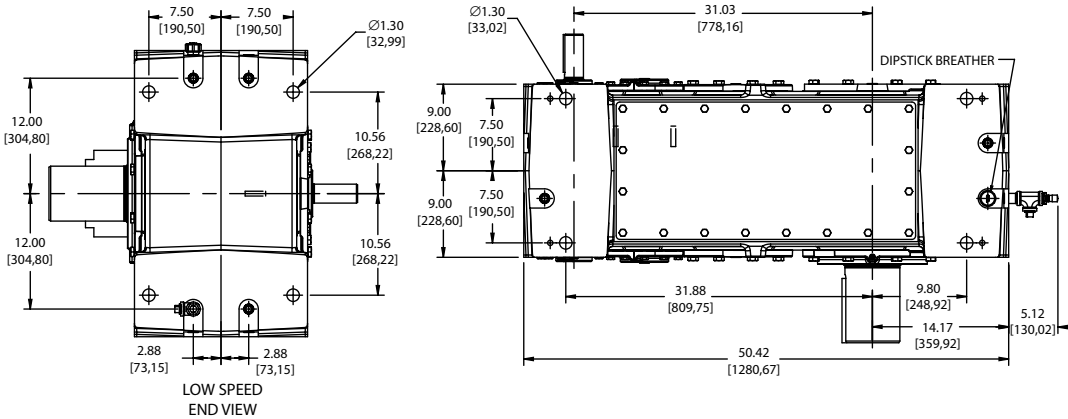

Weight without oil: 3304 lbs  
 Dimensions in [ ] are millimeters.  
 Drawing for reference only. Contact DODGE for certified drawing.

Features/Benefits

Specifications

Nomenclature

Easy Selection

Selection/Dimensions





# SELECTION/DIMENSIONS



## MagnaGear G390 Parallel Shaft DOUBLE REDUCTION (8:1 TO 22.4:1) HOLLOW OUTPUT SHAFT

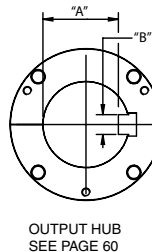
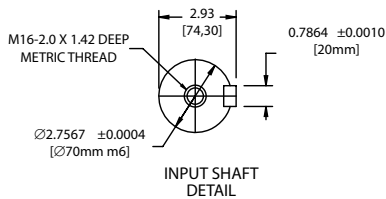
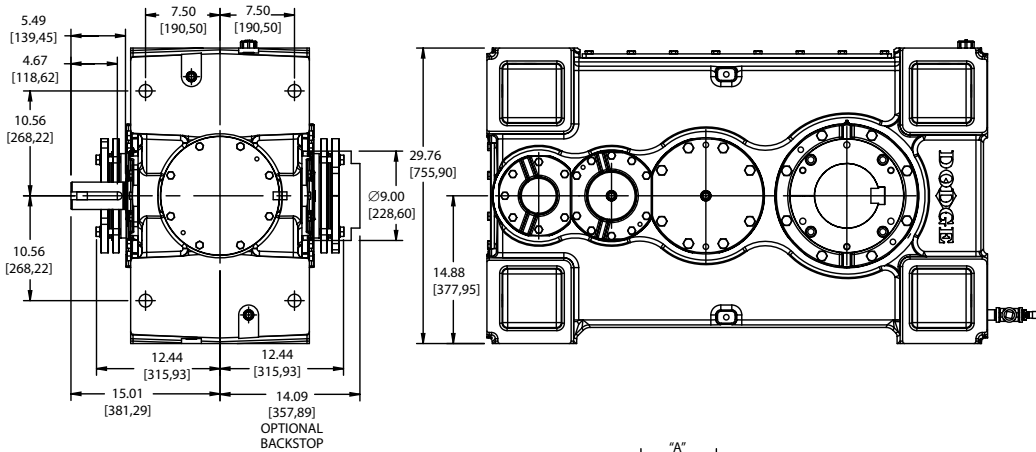
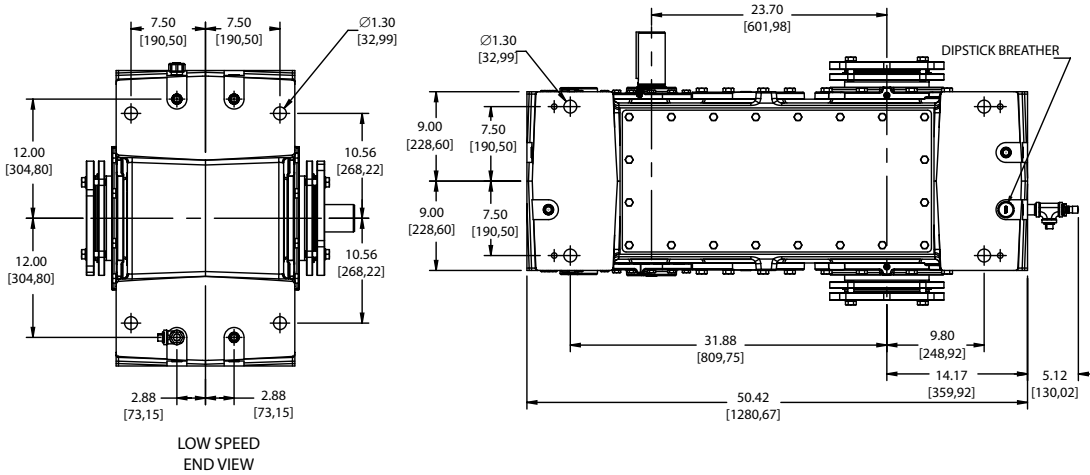

Weight without oil: 3056 lbs  
Dimensions in [ ] are millimeters.  
Drawing for reference only. Contact DODGE for certified drawing.

# SELECTION/DIMENSIONS



## MagnaGear G390 Parallel Shaft TRIPLE REDUCTION (25:1 TO 63:1) HOLLOW OUTPUT SHAFT

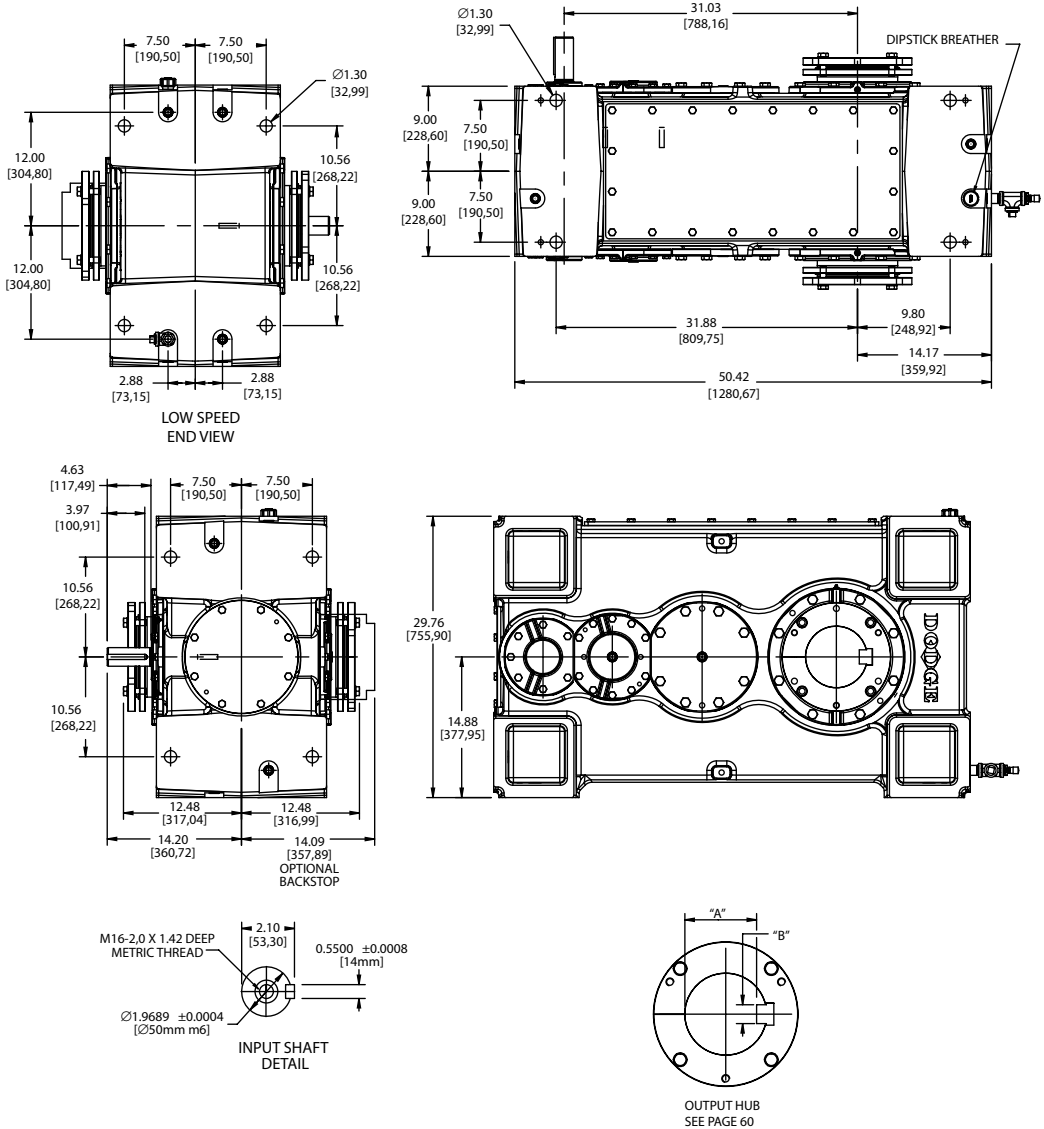

Weight without oil: 3145 lbs  
 Dimensions in [ ] are millimeters.  
 Drawing for reference only. Contact DODGE for certified drawing.

# SELECTION/DIMENSIONS



## MagnaGear G390 Right Angle Shaft TRIPLE REDUCTION (12.5:1 to 63.1:) HOLLOW OUTPUT SHAFT

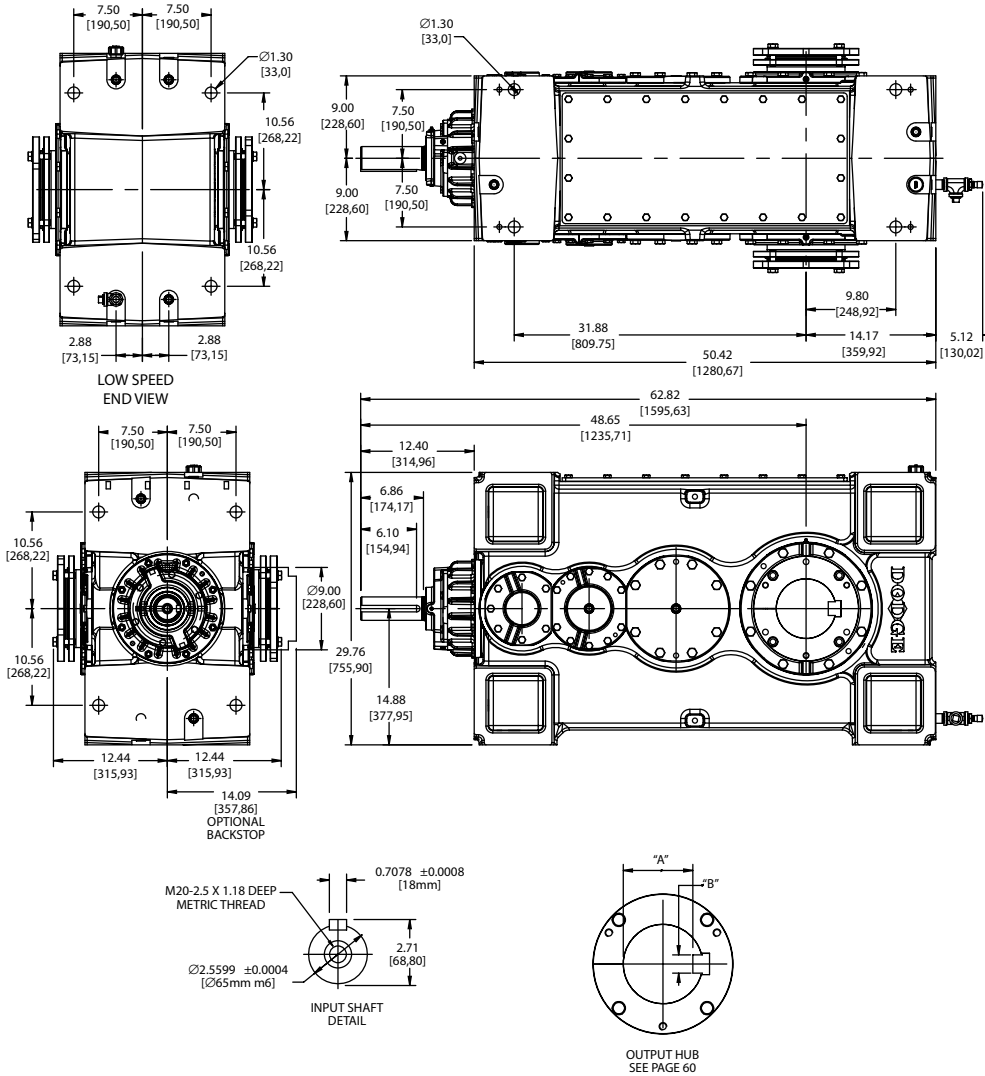

Weight without oil: 3034 lbs  
 Dimensions in [ ] are millimeters.  
 Drawing for reference only. Contact DODGE for certified drawing.

## SELECTION/DIMENSIONS



## MagnaGear G390 Hollow Bore Twin Tapered Bushing Information

Bore Dia.	Twin Tapered Bushing Kit Part Number	Twin Tapered Short Shaft Bushing Kit Part Number	"A"	"B"
7"	454130	272795	6.014"	1-3/4"
6-1/2"	454131	272796	5.662"	1-1/2"
6-7/16"	454132	272797	5.599"	1-1/2"
6"	454133	272798	5.155"	1-1/2"
5-15/16"	454134	272799	5.091"	1-1/2"
5-7/16"	454135	272800	4.740"	1-1/4"
4-15/16"	454136	272801	4.232"	1-1/4"
160mm	454137	272802	147mm	40mm
150mm	454138	272803	138mm	36mm
130mm	454139	272804	119mm	32mm
125mm	454140	272805	114mm	32mm

## MagnaGear G525 Parallel Shaft Part Numbers

Nominal Ratio			Solid Shaft	Solid Shaft with Backstop
D O U B L E	G525HP2	8.00	<b>449713</b>	<b>449725</b>
	G525HP2	9.00	<b>449714</b>	<b>449726</b>
	G525HP2	10.0	<b>449715</b>	<b>449727</b>
	G525HP2	11.2	<b>449716</b>	<b>449728</b>
	G525HP2	12.5	<b>449717</b>	<b>449729</b>
	G525HP2	14.0	<b>449718</b>	<b>449730</b>
	G525HP2	16.0	<b>449719</b>	<b>449731</b>
	G525HP2	18.0	<b>449720</b>	<b>449732</b>
	G525HP2	20.0	<b>449721</b>	<b>449733</b>
	G525HP2	22.4	<b>449722</b>	<b>449734</b>
	G525HP2	25.0	<b>449723</b>	<b>449735</b>
G525HP2	28.0	<b>449724</b>	<b>449736</b>	

## MagnaGear G525 Right Angle Shaft Part Numbers

Nominal Ratio			Solid Shaft	Solid Shaft with Backstop
T R I P L E	G525HR3	12.5	<b>449659</b>	<b>449674</b>
	G525HR3	14.0	<b>449660</b>	<b>449675</b>
	G525HR3	16.0	<b>449661</b>	<b>449676</b>
	G525HR3	18.0	<b>449662</b>	<b>449677</b>
	G525HR3	20.0	<b>449663</b>	<b>449678</b>
	G525HR3	22.4	<b>449664</b>	<b>449679</b>
	G525HR3	25.0	<b>449665</b>	<b>449680</b>
	G525HR3	28.0	<b>449666</b>	<b>449681</b>
	G525HR3	31.5	<b>449667</b>	<b>449682</b>
	G525HR3	35.5	<b>449668</b>	<b>449683</b>
	G525HR3	40.0	<b>449669</b>	<b>449684</b>
	G525HR3	45.0	<b>449670</b>	<b>449685</b>
	G525HR3	50.0	<b>449671</b>	<b>449686</b>
	G525HR3	56.0	<b>449672</b>	<b>449687</b>
G525HR3	63.0	<b>449673</b>	<b>449688</b>	

## G525 Accessory Part Numbers

### Shaft Driven Fan Kits

MagnaGear	Shaft Configuration	Reduction	Ratio	Part Number
G525HP2	Parallel	Double	8 - 28	<b>453954</b>
G525HR3	Right Angle	Triple	12.5 - 63	<b>453959</b>

Mechanical fan kit includes fan, fan shroud, fan guard and mounting hardware.

### Electric Fan Kits

MagnaGear	Shaft Configuration	Reduction	Ratio	Voltage	Phase	Part Number
All G525	All	All	All	230/460	3	<b>454029</b>
All G525	All	All	All	230	1	<b>453388</b>
All G525	All	All	All	575	3	<b>453389</b>

Electrical fan kit includes fan, electric motor, fan shroud, fan guard and mounting hardware.

# SELECTION/DIMENSIONS



## MagnaGear G525 Parallel Shaft DOUBLE REDUCTION (8:1 TO 28:1) SOLID OUTPUT SHAFT

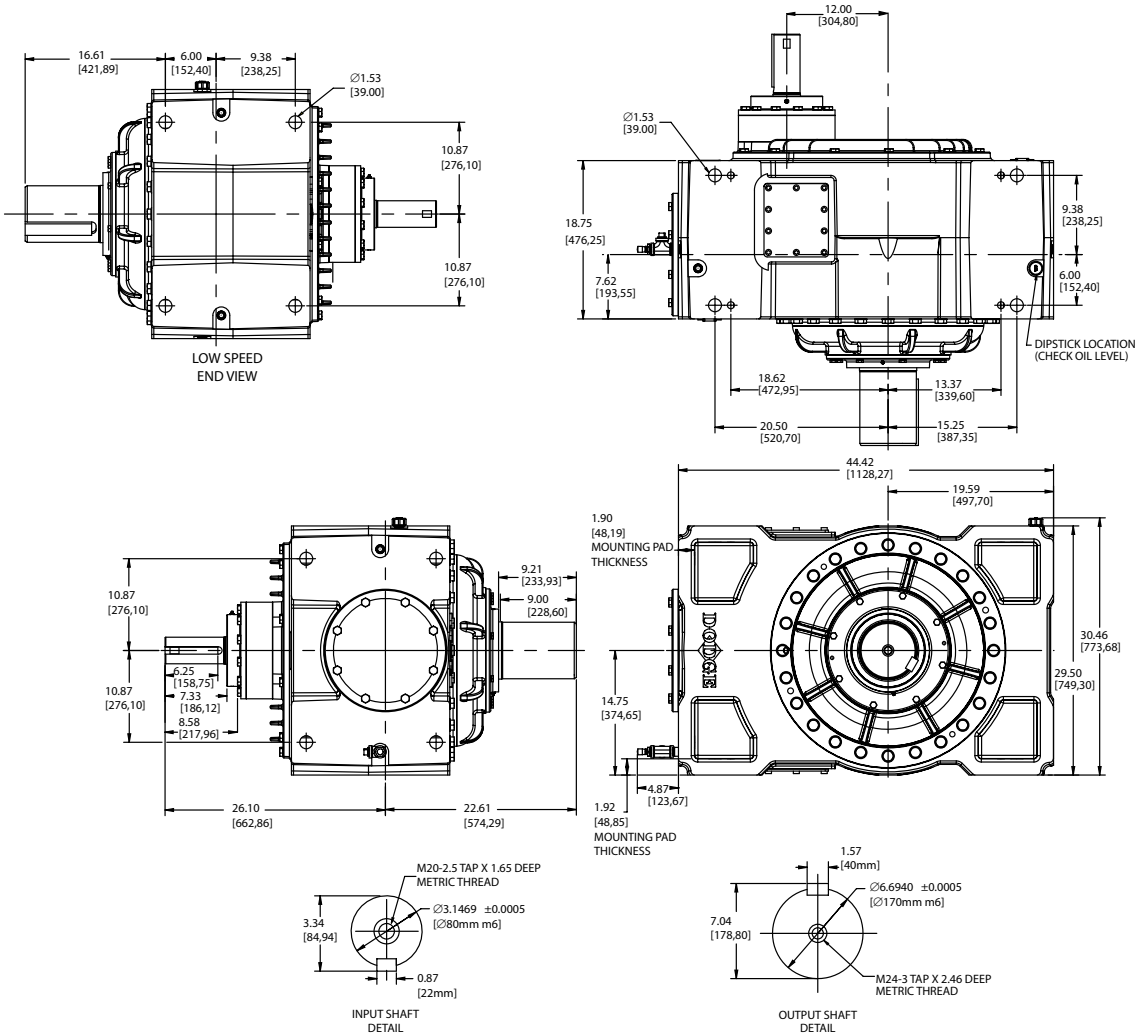

Weight without oil: 3642 lbs  
 Dimensions in [ ] are millimeters.  
 Drawing for reference only. Contact DODGE for certified drawing.

Features/Benefits

Specifications

Nomenclature

Easy Selection

Selection/Dimensions



# SELECTION/DIMENSIONS



## MagnaGear G525 Right Angle Shaft TRIPLE REDUCTION (12.5:1 to 63:1) SOLID OUTPUT SHAFT

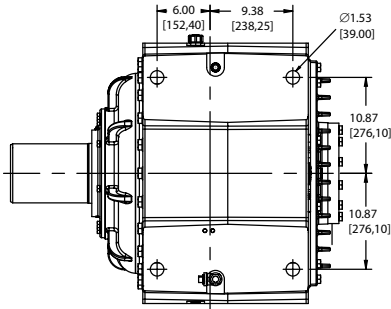

LOW SPEED  
END VIEW

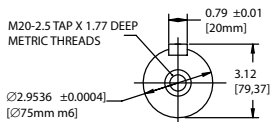
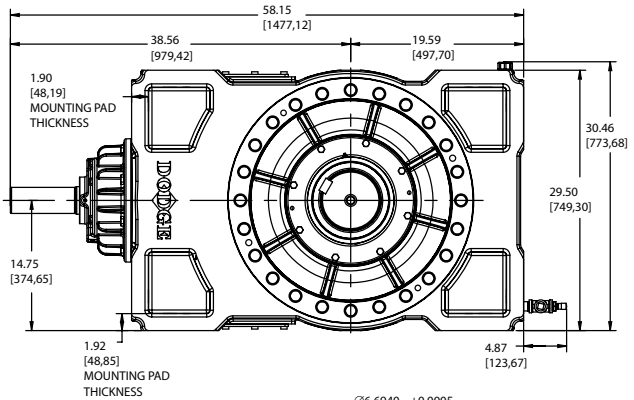
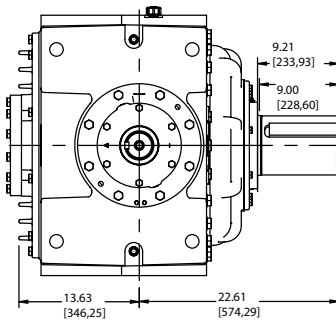
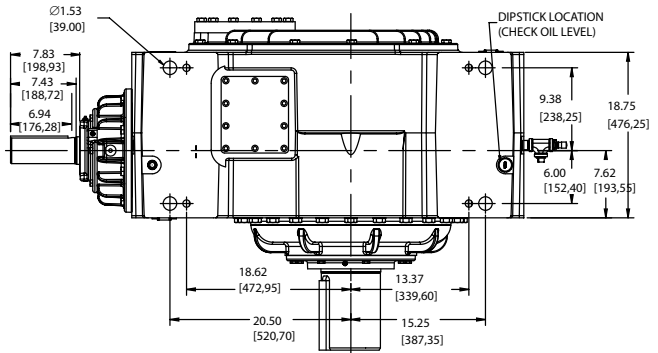

INPUT SHAFT  
DETAIL

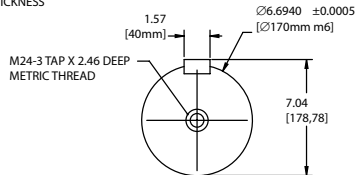

OUTPUT SHAFT  
DETAIL

Weight without oil: 3836 lbs  
Dimensions in [ ] are millimeters.  
Drawing for reference only. Contact DODGE for certified drawing.

## MagnaGear G700 Parallel Shaft Part Numbers

Nominal Ratio			Solid Shaft	Solid Shaft with Backstop
D O U B L E	G700HP2	8.0	<b>449821</b>	<b>449833</b>
	G700HP2	9.0	<b>449822</b>	<b>449834</b>
	G700HP2	10.0	<b>449823</b>	<b>449835</b>
	G700HP2	11.2	<b>449824</b>	<b>449836</b>
	G700HP2	12.5	<b>449825</b>	<b>449837</b>
	G700HP2	14.0	<b>449826</b>	<b>449838</b>
	G700HP2	16.0	<b>449827</b>	<b>449839</b>
	G700HP2	18.0	<b>449828</b>	<b>449840</b>
	G700HP2	20.0	<b>449829</b>	<b>449841</b>
	G700HP2	22.4	<b>449830</b>	<b>449842</b>
	G700HP2	25.0	<b>449831</b>	<b>449843</b>
	G700HP2	28.0	<b>449832</b>	<b>449844</b>

## MagnaGear G700 Right Angle Shaft Part Numbers

Nominal Ratio			Solid Shaft	Solid Shaft with Backstop
T R I P L E	G700HR3	12.5	<b>449767</b>	<b>449782</b>
	G700HR3	14.0	<b>449768</b>	<b>449783</b>
	G700HR3	16.0	<b>449769</b>	<b>449784</b>
	G700HR3	18.0	<b>449770</b>	<b>449785</b>
	G700HR3	20.0	<b>449771</b>	<b>449786</b>
	G700HR3	22.4	<b>449772</b>	<b>449787</b>
	G700HR3	25.0	<b>449773</b>	<b>449788</b>
	G700HR3	28.0	<b>449774</b>	<b>449789</b>
	G700HR3	31.5	<b>449775</b>	<b>449790</b>
	G700HR3	35.5	<b>449776</b>	<b>449791</b>
	G700HR3	40.0	<b>449777</b>	<b>449792</b>
	G700HR3	45.0	<b>449778</b>	<b>449793</b>
	G700HR3	50.0	<b>449779</b>	<b>449794</b>
	G700HR3	56.0	<b>449780</b>	<b>449795</b>
	G700HR3	63.0	<b>449781</b>	<b>449796</b>

## G700 Accessory Part Numbers

### Shaft Driven Fan Kits

MagnaGear	Shaft Configuration	Reduction	Ratio	Part Number
G700HP2	Parallel	Double	8 - 28	<b>454020</b>
G700HR3	Right Angle	Triple	12.5 - 63	<b>454019</b>

Mechanical fan kit includes fan, fan shroud, fan guard and mounting hardware.

### Electric Fan Kits

MagnaGear	Shaft Configuration	Reduction	Ratio	Voltage	Phase	Part Number
All G700	All	All	All	230/460	3	<b>452097</b>
All G700	All	All	All	230	1	<b>452055</b>
All G700	All	All	All	575	3	<b>452054</b>

Electrical fan kit includes fan, electric motor, fan shroud, fan guard and mounting hardware.

# SELECTION/DIMENSIONS



## MagnaGear G700 Parallel Shaft DOUBLE REDUCTION (8:1 TO 28:1) SOLID OUTPUT SHAFT

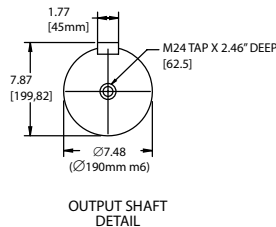
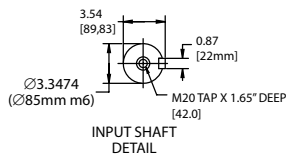
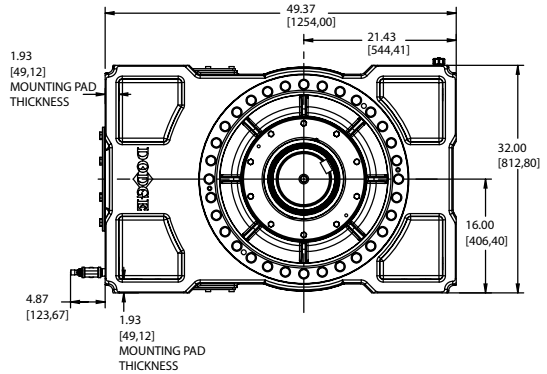
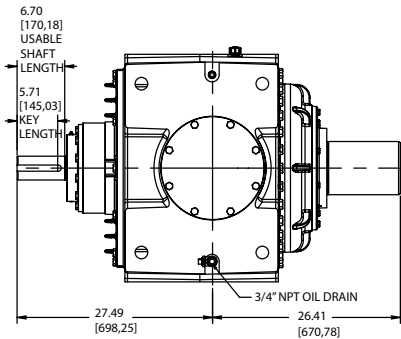
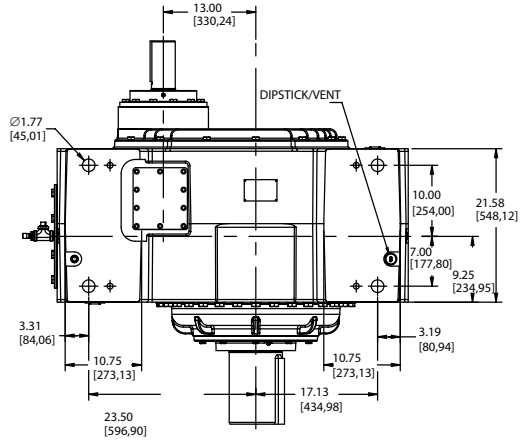
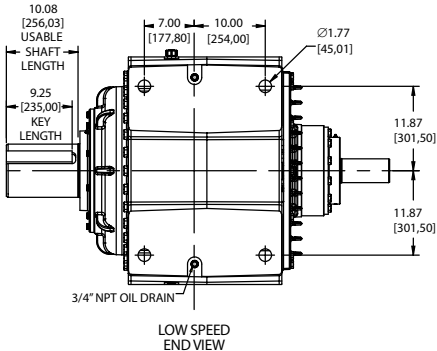

Weight without oil: 4947 lbs  
 Dimensions in [ ] are millimeters.  
 Drawing for reference only. Contact DODGE for certified drawing.

Features/Benefits

Specifications

Nomenclature

Easy Selection

Selection/Dimensions

# SELECTION/DIMENSIONS



## MagnaGear G700 Right Angle Shaft TRIPLE REDUCTION (12.5:1 TO 63:1) SOLID OUTPUT SHAFT

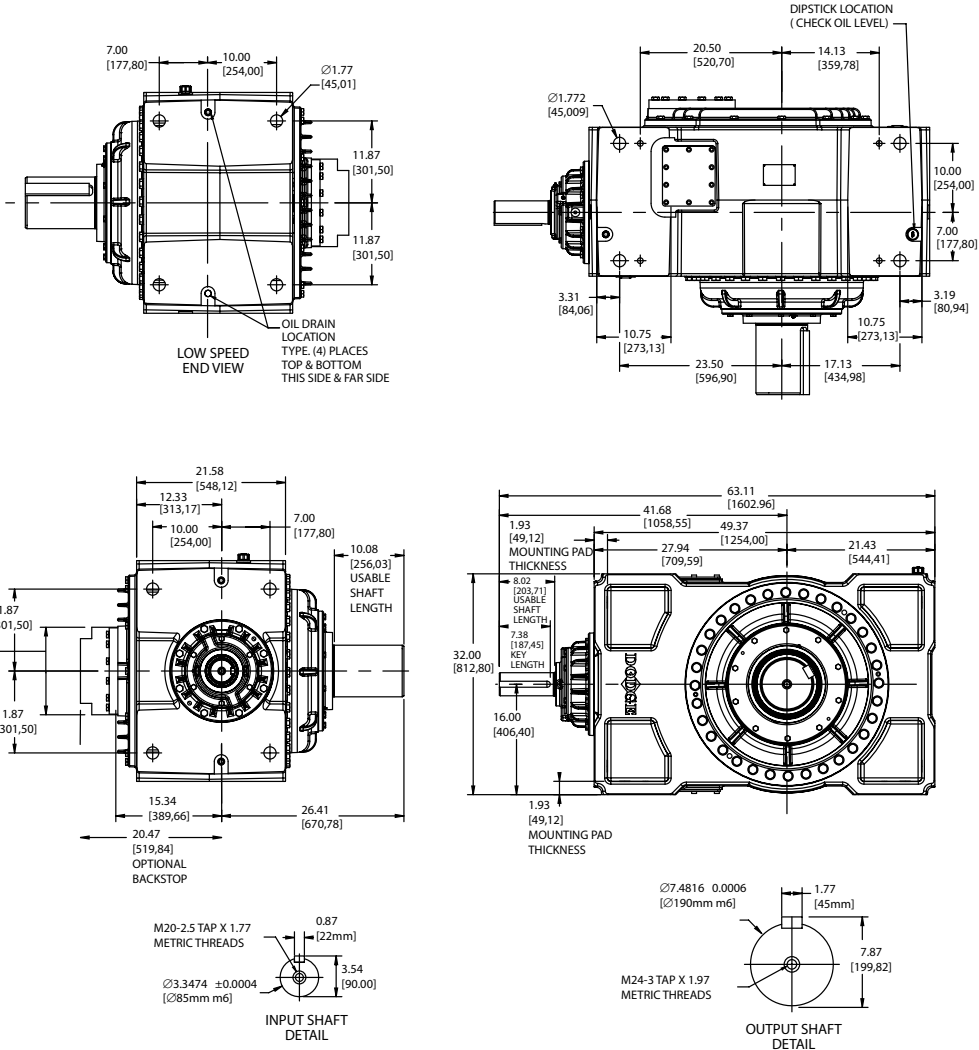

Weight without oil: 5238 lbs  
 Dimensions in [ ] are millimeters.  
 Drawing for reference only. Contact DODGE for certified drawing.

## MagnaGear G920 Parallel Shaft Part Numbers

Nominal Ratio		Solid Shaft	Solid Shaft with Backstop	
D O U B L E	G920HP2	8.00	<b>449929</b>	<b>449941</b>
	G920HP2	9.00	<b>449930</b>	<b>449942</b>
	G920HP2	10.0	<b>449931</b>	<b>449943</b>
	G920HP2	11.2	<b>449932</b>	<b>449944</b>
	G920HP2	12.5	<b>449933</b>	<b>449945</b>
	G920HP2	14.0	<b>449934</b>	<b>449946</b>
	G920HP2	16.0	<b>449935</b>	<b>449947</b>
	G920HP2	18.0	<b>449936</b>	<b>449948</b>
	G920HP2	20.0	<b>449937</b>	<b>449949</b>
	G920HP2	22.4	<b>449938</b>	<b>449950</b>
	G920HP2	25.0	<b>449939</b>	<b>449951</b>
	G920HP2	28.0	<b>449940</b>	<b>449952</b>

## MagnaGear G920 Right Angle Shaft Part Numbers

Nominal Ratio		Solid Shaft	Solid Shaft with Backstop	
T R I P L E	G920HR3	12.5	<b>449875</b>	<b>449890</b>
	G920HR3	14.0	<b>449876</b>	<b>449891</b>
	G920HR3	16.0	<b>449877</b>	<b>449892</b>
	G920HR3	18.0	<b>449878</b>	<b>449893</b>
	G920HR3	20.0	<b>449879</b>	<b>449894</b>
	G920HR3	22.4	<b>449880</b>	<b>449895</b>
	G920HR3	25.0	<b>449881</b>	<b>449896</b>
	G920HR3	28.0	<b>449882</b>	<b>449897</b>
	G920HR3	31.5	<b>449883</b>	<b>449898</b>
	G920HR3	35.5	<b>449884</b>	<b>449899</b>
	G920HR3	40.0	<b>449885</b>	<b>449900</b>
	G920HR3	45.0	<b>449886</b>	<b>449901</b>
	G920HR3	50.0	<b>449887</b>	<b>449902</b>
	G920HR3	56.0	<b>449888</b>	<b>449903</b>
	G920HR3	63.0	<b>449889</b>	<b>449904</b>

## G920 Accessory Part Numbers

### Shaft Driven Fan Kits

MagnaGear	Shaft Configuration	Reduction	Ratio	Part Number
G920HP2	Parallel	Double	8 - 28	<b>454022</b>
G920HR3	Right Angle	Triple	12.5 - 63v	<b>454021</b>

Mechanical fan kit includes fan, fan shroud, fan guard and mounting hardware

### Electric Fan Kits

MagnaGear	Shaft Configuration	Reduction	Ratio	Voltage	Phase	Part Number
All G920	All	All	All	230/460	3	<b>454030</b>
All G920	All	All	All	230	1	<b>454031</b>
All G920	All	All	All	575	3	<b>454032</b>

Electrical fan kit includes fan, electric motor, fan shroud, fan guard and mounting hardware.

# SELECTION/DIMENSIONS



## MagnaGear G920 Parallel Shaft DOUBLE REDUCTION (8:1 TO 28:1) SOLID OUTPUT SHAFT

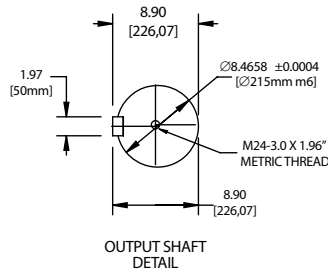
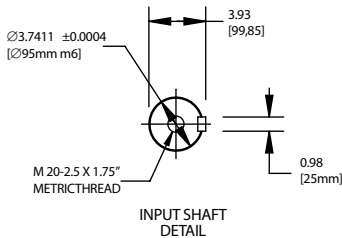
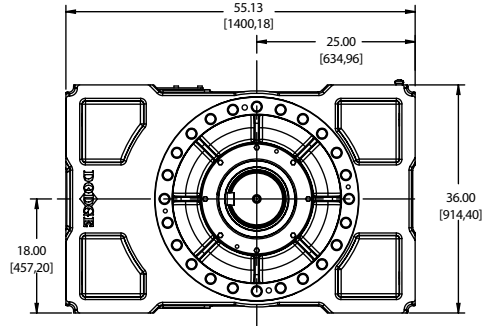
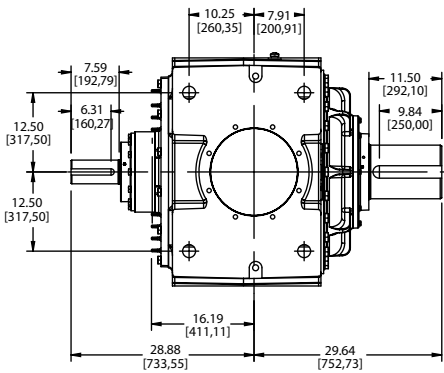
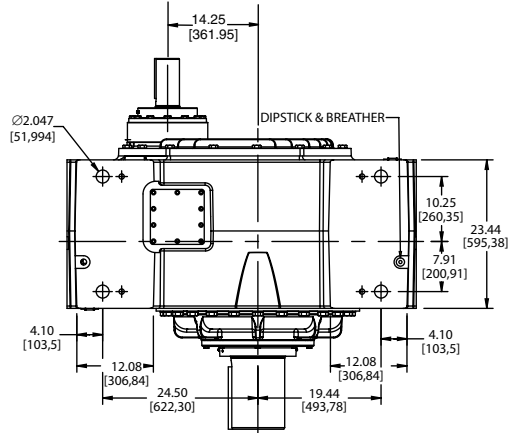
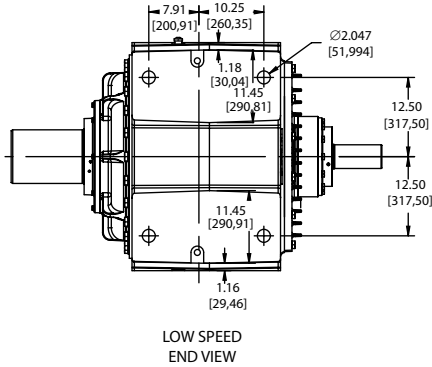

Weight without oil: 6838 lbs  
 Dimensions in [ ] are millimeters.  
 Drawing for reference only. Contact DODGE for certified drawing.

Features/Benefits

Specifications

Nomenclature

Easy Selection

Selection/Dimensions



# SELECTION/DIMENSIONS



## MagnaGear G920 Right Angle Shaft TRIPLE REDUCTION (12.5:1 TO 63:1) SOLID OUTPUT SHAFT

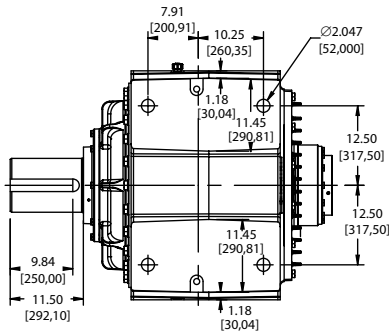

LOW SPEED  
END VIEW

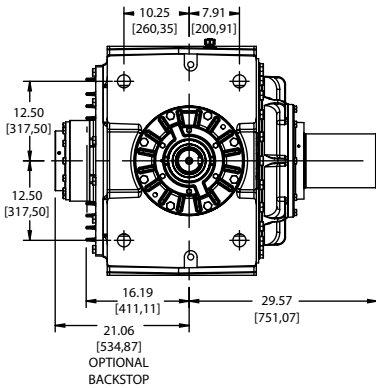
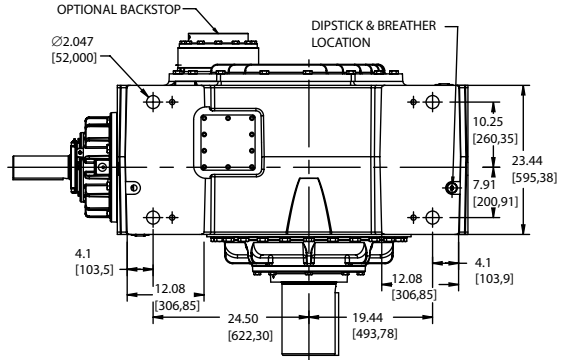

OPTIONAL  
BACKSTOP

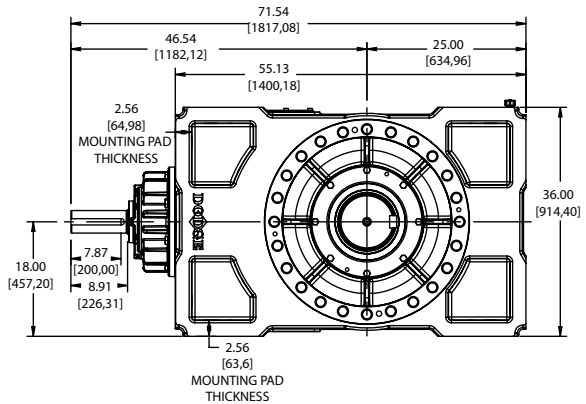

MOUNTING PAD  
THICKNESS

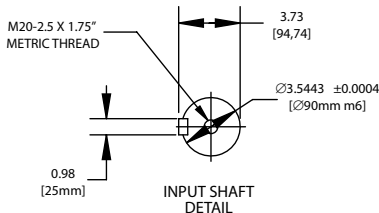

INPUT SHAFT  
DETAIL

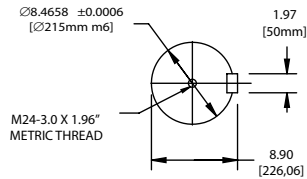

OUTPUT SHAFT  
DETAIL

Weight without oil: 7309 lbs  
Dimensions in [ ] are millimeters.  
Drawing for reference only. Contact DODGE for certified drawing.

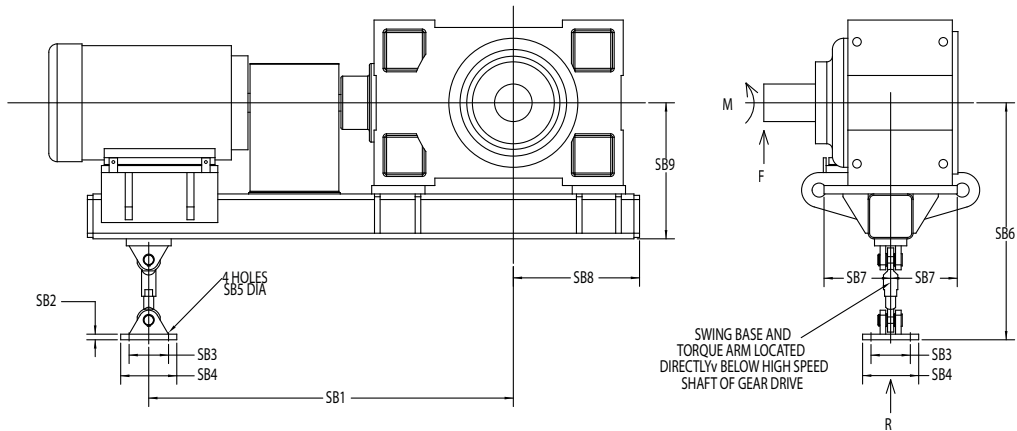

## MagnaGear Swing Base Dimensions - Inches

Drive Size	SB1	SB2	SB3	SB4	SB5	SB6	SB7	SB8	SB9
G100	56.0	0.75	5.00	7.00	0.689	28.4	7.00	12.3	17.25
G150	62.0	0.75	5.00	7.00	0.689	29.7	7.38	12.7	18.5
G210	66.0	0.75	5.00	7.00	0.689	30.9	7.50	13.4	19.8
G285	66.0	0.75	5.00	7.75	0.866	35.7	8.50	15.2	23.1
G390	73.0	0.75	5.25	8.00	0.866	39.4	9.50	16.2	24.2
G525	65.0	1.00	7.00	10.00	1.024	42.1	11.88	23.1	24.3
G700	68.0	1.25	8.00	12.00	1.299	48.9	12.75	25.2	27.8
G920	78.0	1.50	9.00	13.00	1.299	54.9	13.25	28.0	30.3

## Reaction Forces

Drive Size	Torque Condition	Solid Low Speed Shaft			Hollow Low Speed Shaft		
		R Force at Torque Arm (lbs)	F Force at End of Low Speed Shaft (lbs)	M Bending Moment at End of Low Speed Shaft (lb-in)	R Force at Torque Arm (lbs)	F Force at End of Tapered Bushing (lbs)	M Bending Moment at End of Tapered Bushing (lb-in)
G100	100%	4400	3100	45200	4300	3100	31000
	200%	6200	5000	73800	6200	4900	50900
G150	100%	6500	4100	64500	6400	4000	44100
	200%	9200	6800	109300	9100	6700	75700
G210	100%	7500	7100	104100	6600	6000	65700
	200%	10900	10550	167500	10000	9400	102600
G285	100%	8500	8200	127500	8300	7700	88000
	200%	13300	13000	204800	13100	12400	142400
G390	100%	10200	9900	167500	9900	9100	113000
	200%	15600	15300	264000	15300	14500	180100
G525	100%	15500	13300	283900			
	200%	24600	22400	491300			
G700	100%	20200	17000	426600			
	200%	31600	28500	728800			
G920	100%	24900	20500	555900			
	200%	38000	33600	963500			

- Notes:
- 1 - The illustration above is representative and does not agree in exact detail for all sizes.
  - 2 - Gear drives are for horizontally mounted operation (high speed & low speed shaft) unless specifically stated otherwise. Refer to factory if inclined operation is required.
  - 3 - Dimensions are for reference only and are subject to change without notice unless certified.
  - 4 - Reaction forces are provided for 100% and 200% torque conditions. The 100% condition is representative of normal operating loads at full motor horsepower. The 200% condition is representative of maximum loads encountered at start up. Reaction forces provided are based on estimated weights and full mechanical rating (s.f.=1.0). Values will vary based on actual weights and torque transmitted. Reaction forces (R & F) and bending moment (M) for a specific application will be provided during order processing.
  - 5 - For drives with hollow low speed shafts, the location of "M" and "F" is at the outer edge of the tapered bushing.
  - 6 - Reaction forces may be acting in a direction different than shown.

# ENGINEERING/TECHNICAL



## MAGNAGEAR Reducer HORSEPOWER METHOD OF SELECTION

**Step 1: Determine Service Factor** - See Table 2 for electric motor, hydraulic motor, steam turbine or gas turbine driven applications operating up to 10 hours per day or over 10 hours per day. If the application is engine driven, refer to Table 1 to convert the service factor obtained from Table 2 to the service factor required for engine driven applications. Service factor recommendations are minimum. (For extreme shock or high energy loads which must be absorbed, as when stalling, or for power sources not listed, consult DODGE for special consideration.)

**Step 2: Calculate Equivalent Horsepower** - Multiply the actual horsepower to be transmitted by the service factor obtained from Step 1.

**Step 3: Calculate Required Ratio** - Divide the high speed shaft rpm by the low speed shaft rpm.

**Step 4: Determine Unit Size and Ratio** - Refer to the horsepower tables on pages 76 thru 80. From the high speed input shaft rpm in the left hand column and desired ratio and output speed in the next two columns, trace right into the table and find the horsepower rating equal to or greater than the equivalent horsepower obtained from Step 2.

**Step 5: Check Thermal Ratings** - Compare the actual horsepower required (without service factor) with the thermal horsepower capacity by referring to the thermal horsepower rating tables on pages 86 thru 90. If the actual transmitted horsepower exceeds the thermal capacity, a shaft driven auxiliary cooling fan, electric auxiliary cooling fan or a heat exchanger may be added to provide additional thermal capacity or a larger reducer may be required.

**NOTE:** On applications where the continuous running time never exceeds three hours and the idle time is equal to or greater than the running time, thermal limitations can be disregarded and the unit operated at loads up to the listed mechanical rating modified by applicable service factors.

**Step 6: Check Overhung and Thrust Loads** - Consult DODGE if external thrust loads or overhung loads are present.

**Step 7: Check Dimensions** - See applicable pages for dimensions, weights, part numbers and instructions on how to order.

## TORQUE METHOD OF SELECTION

Determine service factor, equivalent torque and unit size using the same steps as outlined above for the horsepower method, except in Step 4 refer to the torque tables on pages 81 thru 85. Convert the required torque without service factor to horsepower by using the following formula:

$$\text{Horsepower} = \frac{\text{Torque (lb-in)} \times \text{Low Speed Shaft rpm}}{63025}$$

and compare the computed results with the thermal capacities shown on pages 86 thru 90.

## EXAMPLES OF SELECTION

### Horsepower Method

A ball mill with a helical ring gear operating at 89 rpm is driven by a 600 horsepower 1750 rpm motor. The duty cycle is 24 hours per day. Ambient conditions at the installation are 90 degrees Fahrenheit ambient temperature and an altitude of 5000 feet above sea level. A parallel shaft reducer is required.

**Step 1: Determine Service Factor** - From Table 2, Service Factors, locate "Mills, Rotary – Ball and Rod Mills with Helical Ring Gear" and under the column headed "10+ Hrs/Day Service" find the Service Factor which is 1.50.

**Step 2: Calculate Equivalent Horsepower** - Multiply the motor horsepower by the service factor (600 x 1.50 = 800) to get the equivalent horsepower of 800.

**Step 3: Calculate Required Ratio** - Divide the high speed shaft rpm by the low speed shaft rpm (1750 / 89 = 19.66) to get the required ratio of 19.66:1.

**Step 4: Determine Unit Size and Ratio** - Locate the horsepower table for parallel shaft MAGNAGEAR reducers with a 1750 high speed shaft rpm (page 76). Trace down the ratio column to the closest nominal ratio to the 19.66:1 required ratio and find 20.0:1 ratio. Trace to the right until the horsepower equals or exceeds the calculated equivalent horsepower of 800 and find 1004 horsepower listed under a MAGNAGEAR G700 reducer.

**Step 5: Check Thermal Ratings** - Refer to the parallel shaft MAGNAGEAR thermal horsepower rating table for parallel reducers on page 86. Locate the table for a 20.0:1 ratio with a 1750 high speed shaft rpm and find the thermal ratings for the MAGNAGEAR G700 reducer. Note the thermal rating without a fan is 262 horsepower, the thermal rating with a shaft fan is 520 horsepower and the thermal rating with an electric fan is 1071 horsepower. These ratings must be adjusted for ambient conditions. From the MAGNAGEAR Thermal Horsepower Rating Adjustment Factor tables on page 90, find the multipliers for 90 degree Fahrenheit ambient temperature and 5000 feet of altitude. Note the factor for 90 degree Fahrenheit ambient is 0.93 and the factor for 5000 feet of altitude is 0.90. (Interpolation can be used to determine factors for values between those listed in the tables). Additional factors for ambient air velocity, duty cycle and maximum oil sump temperature are also provided.

To determine the actual thermal horsepower capacity of the reducer, multiply the thermal horsepower given in the table by the adjustment factors.

## MAGNAGEAR Reducer HORSEPOWER METHOD OF SELECTION

Actual Thermal Hp Capacity =  $1071 * 0.93 * 0.90 = 896.4\text{Hp}$ . Since 896.4 Hp exceeds the input motor horsepower rating of 600 an electric cooling fan will provide adequate cooling for this application. (Using a shaft fan, the Actual Thermal Hp Capacity =  $520 * 0.93 * .90 = 435.2\text{ Hp}$ . Since this is less than the input motor Hp rating of 600 adequate cooling would not be provided).

**Step 6: Check Overhung and Thrust Loads** - Consult Dodge if overhung or thrust loading exists.

**Step 7: Check Dimensions** - Refer to the specifications/ dimensions pages 65-67 for DODGE MAGNAGEAR G700 parallel reducer with a 20.0:1 ratio. The part number for the reducer is **449829** and for the electric cooling fan kit is **452097**. The exact ratio of the reducer is given on pages 90 thru 91 and is 19.567:1.

**Step 8: Check Accessories** - Include any accessories that may be required.

### TORQUE METHOD

Running 10 hours a day, a heavy duty bucket elevator requires 198,237 lb-in of torque at a 43 rpm. The motor speed is 1170 rpm and is coupling connected. Ambient conditions at the installation are 100 degrees Fahrenheit ambient temperature and an altitude of 2,500 feet. A right angle reducer is required.

**Step 1: Determine Service Factor** - From Table 1, Service Factors, locate "ELEVATORS – Bucket – Heavy Duty" and under the column headed "3-10 Hrs/Day Service" locate the service factor which is 1.50.

**Step 2: Calculate Equivalent Torque** - Multiply the system torque of 198,237 by the service factor of 1.50 ( $198,237 * 1.50 = 297,356$ ) to get 297,356 lb-in equivalent torque.

**Step 3: Calculate Required Ratio** - Divide the high speed shaft rpm by the low speed shaft rpm ( $1170 / 43 = 27.2$ ) to get the required ratio of 27.2:1.

**Step 4: Determine Unit Size and Ratio** - Locate the torque table for right angle MAGNAGEAR reducers with a 1170 high speed shaft rpm (page 84). Trace down the ratio column to the closest nominal ratio to the 27.2:1 required ratio and find 28.0:1 ratio. Trace to the right until the torque equals or exceeds the calculated equivalent torque of 297,356 and find 307,000 listed under a MAGNAGEAR G285 reducer.

**Step 5: Check Thermal Ratings** - In order to use the MAGNAGEAR thermal tables the required torque value without service factor (198,237 in-lbs) must be converted to horsepower:

$$\text{Horsepower} = \frac{\text{Torque} \times \text{Reducer Output RPM}}{63025}$$

**Example:**

$$\begin{aligned} \text{Horsepower} &= \frac{198,237 \times (1170/28)}{63025} \\ &= 131.4 \text{ Hp} \end{aligned}$$

Locate the table for the thermal horsepower ratings for right angle MAGNAGEAR reducers on page 87. Locate the table for a 28.0:1 ratio with an 1170 high speed shaft RPM and find the thermal ratings for a MagnaGear G285 Reducer. Note the thermal rating without a fan is 147 horsepower, the thermal rating with a shaft fan is 215 horsepower and the thermal rating with an electric fan is 460 horsepower. These ratings must be adjusted for ambient conditions. From the MAGNAGEAR Thermal Horsepower Rating Adjustment Factor tables on page 89, find the multipliers for 100 degree Fahrenheit ambient temperature and 2,500 feet of altitude. Note the factor for 100 degree Fahrenheit ambient is 0.86 and the factor for 2,500 feet of altitude is 0.95. (Interpolation can be used to determine factors for values between those listed in the tables). Additional factors for ambient air velocity, duty cycle and maximum oil sump temperatures are also provided.

To determine the actual thermal horsepower capacity of the reducer, multiply the thermal horsepower given in the table by the adjustment factors.

Actual Thermal Hp Capacity =  $215 * 0.86 * 0.95 = 184.9\text{ Hp}$ . Since 184.9 Hp exceeds the input motor horsepower rating of 131.4 a shaft fan will provide adequate cooling for this application. (Using no cooling, the Actual Thermal Hp Capacity =  $147 * 0.86 * 0.95 = 126.4\text{ Hp}$ . Since this is less than the input motor Hp rating of 131.4 adequate cooling would not be provided).

**Step 6: Check Overhung and Thrust Loads** - Consult Dodge if overhung or thrust loading exists.

**Step 7: Check Dimensions** - Refer to the specifications/ dimensions pages 43, 44 and 47 for DODGE MAGNAGEAR G285 right angle solid shaft reducer with a 28.0:1 ratio. The part number for the reducer is **449346** and for the shaft driven cooling fan kit is **451526**. The exact ratio of the reducer is given on page 91 and is 28.254:1.

**Step 8: Check Accessories** - Include any accessories that may be required. In the case of an elevator application a backstop is often specified. If a MAGNAGEAR with an integral backstop is required, refer again to the specifications/ dimensions pages 43, 44 and 47 for DODGE MAGNAGEAR G285 right angle solid shaft reducer with a 28.0:1 ratio and a backstop. The part number for the reducer is now **449391**. The part number for the shaft driven cooling fan kit does not change and remains **451526**.

## MAGNAGEAR Parallel Shaft Rating

### Horsepower Rating

(Multiply listed values by 0.7457 to obtain the power Rating in kilowatt)

High Speed Rpm	Nominal Ratio	Approx. Low Speed Rpm	Size							
			100	150	210	285	390	525	700	920
<b>1750</b>	8.00	219	293	466	646	939	1279	1543	2135	2849
	9.00	194	263	418	579	836	1152	1430	1973	2643
	10.0	175	238	378	523	761	1058	1332	1817	2388
	11.2	156	217	346	470	689	947	1233	1631	2166
	12.5	140	200	319	427	623	876	1139	1480	1945
	14.0	125	177	283	386	568	775	1036	1330	1760
	16.0	109	162	258	355	496	649	938	1222	1584
	18.0	97	145	231	315	446	589	845	1113	1435
	20.0	88	125	199	276	398	531	762	1004	1279
	22.4	78	116	185	260	343	475	692	900	1179
	25.0	70	103	165	233	324	437	619	800	1073
	28.0	63	92	142	208	293	391	564	735	979
	31.5	56	83	128	188	264	361	NA	NA	NA
	35.5	49	76	117	168	240	319	NA	NA	NA
	40.0	44	70	108	153	209	292	NA	NA	NA
	45.0	39	62	96	138	188	266	NA	NA	NA
	50.0	35	57	87	120	167	241	NA	NA	NA
56.0	31	51	78	113	155	217	NA	NA	NA	
63.0	28	44	67	98	140	194	NA	NA	NA	

**Note:** Shaded area is Triple Reduction.

**MAGNAGEAR Parallel Shaft Rating**

**Horsepower Rating**

**(Multiply listed values by 0.7457 to obtain the power Rating in kilowatt)**

High Speed Rpm	Nominal Ratio	Approx. Low Speed Rpm	Size							
			100	150	210	285	390	525	700	920
<b>1430</b>	8.0	179	244	389	539	784	1068	1340	1862	2429
	9.0	159	219	349	483	698	962	1242	1682	2206
	10.0	143	198	315	436	635	882	1156	1515	1991
	11.2	128	180	288	391	574	788	1040	1359	1806
	12.5	114	166	265	355	518	728	948	1233	1621
	14.0	102	147	235	321	472	644	863	1107	1467
	16.0	89	134	214	295	412	539	781	1017	1319
	18.0	79	120	192	262	371	490	703	926	1194
	20.0	72	104	165	230	331	442	633	836	1064
	22.4	64	96	154	216	286	395	575	749	981
	25.0	57	86	137	194	269	364	514	665	892
	28.0	51	77	118	173	243	325	469	610	813
	31.5	45	69	107	156	220	300	NA	NA	NA
	35.5	40	63	97	140	200	265	NA	NA	NA
	40.0	36	58	89	127	174	242	NA	NA	NA
	45.0	32	52	79	115	156	221	NA	NA	NA
	50.0	29	47	72	99	139	200	NA	NA	NA
56.0	26	42	65	93	129	180	NA	NA	NA	
63.0	23	36	55	82	116	160	NA	NA	NA	

**Note:** Shaded area is Triple Reduction.

## MAGNAGEAR Parallel Shaft Rating

### Horsepower Rating

(Multiply listed values by 0.7457 to obtain the power Rating in kilowatt)

High Speed Rpm	Nominal Ratio	Approx. Low Speed Rpm	Size							
			100	150	210	285	390	525	700	920
<b>1170</b>	8.00	146	204	325	450	655	892	1180	1554	2028
	9.00	130	182	291	403	582	802	1068	1404	1842
	10.0	117	165	262	363	528	735	964	1264	1662
	11.2	104	150	239	325	477	655	867	1133	1506
	12.5	94	138	220	295	431	606	790	1028	1352
	14.0	84	122	195	267	393	536	719	923	1223
	16.0	73	112	178	246	343	449	650	847	1098
	18.0	65	100	160	218	309	408	585	771	995
	20.0	59	86	138	191	276	368	527	695	886
	22.4	52	80	128	180	238	329	479	623	816
	25.0	47	71	114	161	224	303	428	553	742
	28.0	42	64	98	144	203	271	390	507	676
	31.5	37	58	89	130	183	250	NA	NA	NA
	35.5	33	53	81	116	166	220	NA	NA	NA
	40.0	29	48	74	105	145	201	NA	NA	NA
	45.0	26	43	66	95	130	183	NA	NA	NA
	50.0	23	39	60	82	115	166	NA	NA	NA
56.0	21	35	53	77	107	149	NA	NA	NA	
63.0	19	30	46	68	96	133	NA	NA	NA	

**Note:** Shaded area is Triple Reduction.

**MAGNAGEAR Right Angle Rating**

**Horsepower Rating**

**(Multiply listed values by 0.7457 to obtain the power Rating in kilowatt)**

High Speed Rpm	Nominal Ratio	Approx. Low Speed Rpm	Size							
			100	150	210	285	390	525	700	920
<b>1750</b>	12.5	140	199	317	439	566	666	1014	1385	1766
	14.0	125	178	284	394	538	628	1014	1385	1791
	16.0	109	161	256	355	478	595	941	1234	1621
	18.0	97	140	223	318	435	567	846	1107	1470
	20.0	88	126	201	288	393	532	771	1003	1320
	22.4	78	115	183	250	355	480	701	901	1198
	25.0	70	106	169	226	313	434	594	778	1072
	28.0	63	94	150	205	291	372	542	705	927
	31.5	56	86	137	189	263	331	492	632	841
	35.5	49	77	123	167	239	298	445	580	752
	40.0	44	66	106	146	208	272	400	528	681
	45.0	39	59	94	130	187	245	360	476	606
	50.0	35	56	89	121	167	221	327	426	558
	56.0	31	50	80	110	155	199	292	378	507
	63.0	28	45	73	101	140	174	266	346	462
<b>1430</b>	12.5	114	165	263	366	470	554	880	1203	1534
	14.0	102	148	236	327	447	522	836	1142	1477
	16.0	89	133	213	295	397	494	783	1027	1351
	18.0	79	116	185	264	361	472	704	921	1224
	20.0	72	105	167	240	327	434	642	835	1098
	22.4	64	96	152	207	295	392	583	749	996
	25.0	57	88	140	188	260	355	494	646	891
	28.0	51	78	125	170	242	310	450	585	771
	31.5	45	71	114	157	219	275	409	525	699
	35.5	40	64	102	139	199	248	370	482	625
	40.0	36	55	88	122	173	222	332	438	565
	45.0	32	49	78	108	155	200	299	395	503
	50.0	29	46	74	100	138	181	271	353	463
	56.0	26	42	66	91	128	162	242	313	421
	63.0	23	38	60	83	116	143	220	287	383



## MAGNAGEAR Right Angle Rating

### Horsepower Rating

(Multiply listed values by 0.7457 to obtain the power Rating in kilowatt)

High Speed Rpm	Nominal Ratio	Approx. Low Speed Rpm	Size							
			100	150	210	285	390	525	700	920
<b>1170</b>	12.5	94	137	219	305	391	461	765	1045	1332
	14.0	84	123	196	272	372	434	723	951	1253
	16.0	73	111	177	245	331	412	652	856	1125
	18.0	65	97	154	220	301	393	586	767	1019
	20.0	59	87	139	199	273	355	534	695	914
	22.4	52	80	127	173	246	321	485	623	829
	25.0	47	73	117	157	217	290	411	537	742
	28.0	42	65	104	142	202	258	374	487	641
	31.5	37	59	95	130	182	229	340	436	581
	35.5	33	53	85	115	165	206	307	400	519
	40.0	29	46	73	101	144	182	276	364	470
	45.0	26	41	65	89	129	164	248	328	418
	50.0	23	38	61	83	115	148	225	293	384
	56.0	21	34	55	76	106	133	201	260	349
	63.0	19	31	50	69	96	117	183	238	318

**MAGNAGEAR Parallel Shaft Rating**

**Torque Rating (1,000 In-Lbs)**

**(Multiply listed values by 113 to obtain torque in Nm)**

High Speed Rpm	Nominal Ratio	Approx. Low Speed Rpm	Size							
			100	150	210	285	390	525	700	920
<b>1750</b>	8.0	219	85	137	187	262	357	455	621	837
	9.0	194	86	138	190	266	362	471	643	860
	10.0	175	87	140	192	269	365	491	665	875
	11.2	156	88	142	194	272	370	511	673	884
	12.5	140	89	143	196	275	373	522	680	895
	14.0	125	90	144	198	278	378	527	688	901
	16.0	109	91	145	200	282	385	533	694	915
	18.0	97	91	147	202	285	389	538	701	924
	20.0	88	93	149	204	288	393	544	708	935
	22.4	78	93	150	205	292	397	549	716	943
	25.0	70	94	152	208	294	400	555	724	951
	28.0	63	95	154	210	296	405	559	730	960
	31.5	56	96	155	212	299	408	NA	NA	NA
	35.5	49	97	157	215	301	412	NA	NA	NA
	40.0	44	98	158	217	305	415	NA	NA	NA
	45.0	39	99	160	219	308	418	NA	NA	NA
	50.0	35	100	161	221	311	422	NA	NA	NA
56.0	31	100	162	222	313	425	NA	NA	NA	
63.0	28	102	164	225	306	429	NA	NA	NA	

**NOTE:** Shaded area is Triple Reduction

## MAGNAGEAR Parallel Shaft Rating

Torque Rating (1,000 In-Lbs)

(Multiply listed values by 113 to obtain torque in Nm)

High Speed Rpm	Nominal Ratio	Approx. Low Speed Rpm	Size							
			100	150	210	285	390	525	700	920
<b>1430</b>	8.00	179	87	140	191	268	365	483	663	873
	9.00	159	88	141	194	272	370	500	671	879
	10.0	143	89	143	196	274	373	521	679	893
	11.2	128	90	144	198	277	377	527	687	902
	12.5	114	90	145	200	280	379	532	694	884
	14.0	102	91	147	202	282	384	537	701	919
	16.0	89	92	148	203	286	392	542	707	932
	18.0	79	93	149	205	290	396	548	714	942
	20.0	72	94	151	208	293	400	553	721	952
	22.4	64	95	153	209	297	404	558	728	960
	25.0	57	96	154	212	299	407	564	736	968
	28.0	51	97	156	214	302	412	569	742	976
	31.5	45	98	158	216	304	415	NA	NA	NA
	35.5	40	99	159	218	307	419	NA	NA	NA
	40.0	36	99	160	220	310	422	NA	NA	NA
	45.0	32	100	162	222	313	425	NA	NA	NA
	50.0	29	101	163	225	315	428	NA	NA	NA
	56.0	26	102	164	226	317	432	NA	NA	NA
63.0	23	103	166	228	310	435	NA	NA	NA	

**Note:** Shaded area is Triple Reduction.

**MAGNAGEAR Parallel Shaft Rating**

**Torque Rating (1,000 In-Lbs)**

**(Multiply listed values by 113 to obtain torque in Nm)**

High Speed Rpm	Nominal Ratio	Approx. Low Speed Rpm	Size							
			100	150	210	285	390	525	700	920
<b>1170</b>	8.00	146	89	142	195	274	373	520	677	891
	9.00	130	90	144	197	277	377	525	684	897
	10.0	117	90	145	199	279	379	531	692	910
	11.2	104	91	146	201	282	383	537	700	920
	12.5	94	92	148	203	284	386	542	707	901
	14.0	84	93	149	205	287	391	547	714	936
	16.0	73	94	150	207	291	398	552	720	949
	18.0	65	94	152	209	295	403	557	726	958
	20.0	59	96	154	212	298	407	563	733	969
	22.4	52	96	155	213	303	412	568	741	976
	25.0	47	98	157	215	304	414	573	748	984
	28.0	42	98	159	218	307	419	578	754	992
	31.5	37	99	161	220	310	422	NA	NA	NA
	35.5	33	100	162	222	312	426	NA	NA	NA
	40.0	29	101	163	224	315	429	NA	NA	NA
	45.0	26	102	164	225	317	431	NA	NA	NA
	50.0	23	102	165	228	320	434	NA	NA	NA
	56.0	21	103	166	229	321	437	NA	NA	NA
63.0	19	104	168	231	314	440	NA	NA	NA	

**Note:** Shaded area is Triple Reduction.

## MAGNAGEAR Right Angle Rating

Torque Rating (1,000 In-Lbs)

(Multiply listed values by 113 to obtain torque in Nm)

High Speed Rpm	Nominal Ratio	Approx. Low Speed Rpm	Size							
			100	150	210	285	390	525	700	920
<b>1750</b>	12.5	140	89	143	196	259	301	459	619	797
	14.0	125	90	144	198	279	326	512	693	896
	16.0	109	91	146	200	283	347	532	694	912
	18.0	97	92	147	202	285	364	538	701	922
	20.0	88	92	149	204	288	386	543	708	932
	22.4	78	93	150	206	291	380	548	716	941
	25.0	70	94	151	208	285	393	557	726	952
	28.0	63	95	153	210	296	390	561	732	965
	31.5	56	96	154	212	299	378	566	740	973
	35.5	49	97	156	215	302	390	571	745	983
	40.0	44	98	158	217	305	392	576	751	992
	45.0	39	99	160	220	308	391	581	758	1002
	50.0	35	100	161	221	311	392	586	765	1009
	56.0	31	100	162	223	313	394	591	773	1017
63.0	28	101	163	224	306	391	596	778	1024	
<b>1430</b>	12.5	114	90	145	199	263	307	487	658	846
	14.0	102	91	147	201	284	331	517	699	904
	16.0	89	92	148	203	287	353	542	707	930
	18.0	79	93	150	205	290	370	548	714	939
	20.0	72	94	151	207	293	386	553	721	949
	22.4	64	95	153	210	296	380	558	728	958
	25.0	57	96	154	212	290	393	566	738	968
	28.0	51	97	156	214	302	397	571	745	981
	31.5	45	98	157	216	305	385	575	752	989
	35.5	40	99	159	218	307	397	580	757	999
	40.0	36	100	161	221	310	392	585	763	1008
	45.0	32	101	162	223	313	391	590	770	1017
	50.0	29	101	163	224	316	392	595	777	1024
	56.0	26	102	164	226	317	394	600	784	1032
63.0	23	103	165	227	311	391	604	789	1040	

**MAGNAGEAR Right Angle Rating**

**Torque Rating (1,000 In-Lbs)**

**(Multiply listed values by 113 to obtain torque in Nm)**

High Speed Rpm	Nominal Ratio	Approx. Low Speed Rpm	Size							
			100	150	210	285	390	525	700	920
<b>1170</b>	12.5	94	92	148	202	268	312	518	699	899
	14.0	84	93	149	205	289	337	546	712	937
	16.0	73	94	151	207	293	359	552	719	947
	18.0	65	95	153	209	296	377	557	727	956
	20.0	59	96	154	211	299	386	562	733	966
	22.4	52	97	155	214	302	380	567	741	975
	25.0	47	97	157	216	296	393	575	750	984
	28.0	42	98	158	218	307	404	580	757	997
	31.5	37	99	160	220	310	392	584	763	1005
	35.5	33	100	161	222	312	404	589	769	1015
	40.0	29	101	163	224	315	392	594	775	1023
	45.0	26	102	164	226	317	391	599	781	1033
	50.0	23	102	165	227	320	392	603	788	1039
	56.0	21	103	166	229	321	394	609	795	1047
	63.0	19	104	167	230	314	391	613	800	1054

## MagnaGear Thermal Horsepower Ratings

### Parallel Shaft

Ratings based on 80°F ambient and sea level altitude. Refer to page 90 for adjustment factors if these condition do not apply.

Nominal Ratios	HS Shaft rpm	Cooling	Reducer Size							
			100	150	210	285	390	525	700	920
8 - 10	1750	None	114	143	177	206	221	222	275	308
		Shaft Fan	220	268	343	415	452	470	544	585
		Electric Fan	378	471	585	698	818	931	1103	1239
	1430	None	110	143	175	206	239	234	275	308
		Shaft Fan	206	251	322	389	424	441	510	548
		Electric Fan	408	527	649	770	861	1052	1246	1170
	1170	None	119	154	190	223	245	234	275	308
		Shaft Fan	185	226	290	350	381	397	459	493
		Electric Fan	386	498	614	728	813	994	992	1105
	870	None	130	169	208	244	259	234	275	308
		Shaft Fan	169	220	271	319	337	305	359	403
		Electric Fan	364	456	580	632	694	849	847	944
12.5 - 14	1750	None	111	140	173	202	216	217	277	307
		Shaft Fan	189	238	302	363	389	437	549	584
		Electric Fan	361	466	575	681	762	931	1103	1239
	1430	None	110	143	176	206	226	217	276	306
		Shaft Fan	174	219	279	335	359	403	506	539
		Electric Fan	339	438	540	640	716	874	1036	1164
	1170	None	116	150	185	217	238	234	275	308
		Shaft Fan	178	225	285	343	367	413	518	551
		Electric Fan	320	412	509	603	674	824	976	1097
	870	None	112	145	179	210	230	226	266	298
		Shaft Fan	155	195	248	299	319	359	451	480
		Electric Fan	293	378	466	553	618	755	895	1006
16 - 20	1750	None	105	133	164	191	205	206	262	291
		Shaft Fan	179	225	286	344	368	414	520	553
		Electric Fan	312	403	496	589	658	834	1071	1192
	1430	None	102	133	164	192	211	217	275	297
		Shaft Fan	164	206	262	315	337	379	476	507
		Electric Fan	293	378	466	553	618	782	1005	1118
	1170	None	101	132	162	190	208	214	272	293
		Shaft Fan	145	182	232	279	298	335	421	448
		Electric Fan	275	355	438	519	580	735	944	1051
	870	None	97	126	155	181	199	205	260	280
		Shaft Fan	130	163	207	249	266	300	376	400
		Electric Fan	251	325	400	475	531	672	863	961

### MagnaGear Thermal Horsepower Ratings

#### Parallel Shaft

Ratings based on 80°F ambient and sea level altitude. Refer to page 90 for adjustment factors if these condition do not apply.

Nominal Ratios	HS Shaft rpm	Cooling	Reducer Size							
			100	150	210	285	390	525	700	920
22 - 28:1	1750	None	96	120	149	174	186	187	238	264
		Shaft Fan	163	205	260	313	334	376	472	502
		Electric Fan	279	360	443	526	588	745	956	1064
	1430	None	93	120	148	174	190	196	259	268
		Shaft Fan	147	186	236	284	303	341	428	455
		Electric Fan	261	337	415	492	550	697	895	996
	1170	None	88	116	145	171	192	198	260	270
		Shaft Fan	129	163	207	249	266	299	375	399
		Electric Fan	244	316	389	461	516	653	839	934
	870	None	83	112	140	165	187	193	254	255
		Shaft Fan	108	136	173	208	222	250	314	334
		Electric Fan	223	288	355	421	470	596	765	851

### MagnaGear Thermal Horsepower Ratings

#### Parallel Shaft

Ratings based on 80°F ambient and sea level altitude. Refer to page 89 for adjustment factors if these condition do not apply.

Nominal Ratios	HS Shaft rpm	Cooling	Reducer Size				
			100	150	210	285	390
31.5 - 45	1750	None	92	116	143	167	179
		Shaft Fan	139	175	223	268	286
		Electric Fan	240	310	382	453	506
	1430	None	89	112	139	162	173
		Shaft Fan	127	159	202	243	260
		Electric Fan	222	286	353	419	468
	1170	None	85	107	133	155	166
		Shaft Fan	112	141	179	216	231
		Electric Fan	207	268	330	392	438
50 - 63:1	1750	None	82	104	128	150	160
		Shaft Fan	119	150	191	229	245
		Electric Fan	224	289	357	423	473
	1430	None	80	100	124	144	154
		Shaft Fan	108	136	173	208	223
		Electric Fan	208	268	330	392	438
	1170	None	74	97	115	139	144
		Shaft Fan	96	124	154	190	197
		Electric Fan	222	248	353	363	468



## MagnaGear Thermal Horsepower Ratings

### Right Angle Shaft

Ratings based on 80°F ambient and sea level altitude. Refer to page 90 for adjustment factors if these condition do not apply.

Nominal Ratios	HS Shaft rpm	Cooling	Reducer Size							
			100	150	210	285	390	525	700	920
12.5 - 18	1750	None	95	124	156	173	184	179	208	238
		Shaft Fan	164	212	267	305	325	425	493	495
		Electric Fan	305	396	498	580	618	709	822	942
	1430	None	92	124	158	170	196	191	222	254
		Shaft Fan	160	209	265	301	328	436	506	508
		Electric Fan	290	375	473	550	586	672	780	893
	1170	None	97	132	168	181	199	198	233	272
		Shaft Fan	152	198	249	285	303	397	459	462
		Electric Fan	274	355	447	521	555	636	738	845
	870	None	90	122	156	166	188	187	223	258
		Shaft Fan	105	152	171	219	208	304	315	355
		Electric Fan	260	324	424	475	525	580	699	771
20 - 28	1750	None	84	109	138	153	163	158	184	210
		Shaft Fan	139	180	227	259	276	361	419	421
		Electric Fan	273	354	445	519	553	634	735	841
	1430	None	79	107	136	147	157	156	186	221
		Shaft Fan	129	167	210	241	256	350	388	390
		Electric Fan	257	333	420	489	521	597	692	793
	1170	None	79	108	137	147	162	161	190	221
		Shaft Fan	115	149	188	215	229	320	348	349
		Electric Fan	242	314	395	460	491	562	652	747
	870	None	76	103	131	140	159	157	188	218
		Shaft Fan	97	126	159	181	193	283	293	294
		Electric Fan	221	286	361	420	447	513	595	681

### MagnaGear Thermal Horsepower Ratings

#### Right Angle Shaft

Ratings based on 80°F ambient and sea level altitude. Refer to page 90 for adjustment factors if these condition do not apply.

Nominal Ratios	HS Shaft rpm	Cooling	Reducer Size							
			100	150	210	285	390	525	700	920
31.5 - 45	1750	None	76	99	124	138	147	143	166	190
		Shaft Fan	112	145	183	209	223	291	338	339
		Electric Fan	223	289	365	425	452	518	601	689
	1430	None	75	97	122	136	145	141	163	187
		Shaft Fan	103	133	168	191	204	267	309	311
		Electric Fan	208	270	340	396	422	484	561	642
	1170	None	73	94	119	132	141	137	159	182
		Shaft Fan	90	117	148	169	180	235	272	274
		Electric Fan	195	253	319	371	395	453	526	602
	870	None	67	87	110	122	130	127	147	169
		Shaft Fan	76	99	125	143	152	199	231	232
		Electric Fan	177	230	289	337	359	411	477	546
50 - 63:1	1750	None	67	86	109	121	129	125	145	166
		Shaft Fan	94	121	153	175	186	243	282	284
		Electric Fan	199	258	326	379	404	463	537	615
	1430	None	65	84	106	117	125	122	141	162
		Shaft Fan	85	111	139	159	170	222	257	258
		Electric Fan	185	240	302	352	375	430	498	570
	1170	None	62	80	101	112	119	116	134	154
		Shaft Fan	76	98	124	141	151	197	228	229
		Electric Fan	174	226	285	331	353	405	469	537
	870	None	57	74	93	103	110	107	124	142
		Shaft Fan	64	83	105	120	127	167	193	194
		Electric Fan	159	206	259	302	322	369	428	490

## MagnaGear Thermal Ratings

### Ambient Temperature Adjustment Factors

Ambient Temperature (°F)	$B_{ref}$
50	1.19
60	1.13
70	1.07
80	1.00
90	0.93
100	0.86
110	0.78
120	0.69

### Altitude Adjustment Factors

Altitude (ft)	$B_A$
0 - Sea Level	1.00
2500	0.95
5000	0.90
7500	0.85
10000	0.81
12500	0.76
15000	0.72
17500	0.68

### Ambient Air Velocity Adjustment Factors (Does Not Apply to Reducers with Fan Cooling)

Ambient Air Velocity (fpm)	Typical Environment	$B_V$
≤ 100	Small Confined Space	0.75
> 100 and ≤ 275	Large Indoor Space	1.00
> 275 and < 725	Large Indoor Space	1.40
≥ 725	Outdoors	1.90

### Duty Cycle Temperature Adjustment Factors

Operation Time per Hour	$B_D$
100% (3 or more hours continuous)	1.00
80% (Ave 48 min per hour)	1.05
60% (Ave 36 min per hour)	1.15
40% (Ave 24 min per hour)	1.35
20% (Ave 12 min per hour)	1.80

### Maximum Allowable Oil Sump Temperature Adjustment Factors

Max Oil Sump Temp °F	$B_T$
185	0.81
200	1.00
220	1.13

To determine the actual thermal Hp rating, multiply the rating from the thermal Hp tables by the appropriate factors from the tables above.

### Actual Thermal Hp = Thermal Hp Rating from Table \* $B_{ref}$ \* $B_A$ \* $B_D$ \* $B_T$ \* $B_V$

**Example:** A MagnaGear G525 with a shaft fan, right angle, 25:1 ratio will be operated with a 1750RPM input motor. Ambient conditions at the installation site are 100F, 2500ft altitude. MagnaGear will be located in a large indoor space. Duty cycle will be 12 hours continuous operation per day, maximum allowable oil sump temperature is 200F. To calculate the actual thermal Hp rating, find the rated thermal Hp from the right angle thermal Hp table and multiply by the appropriate rating factors. Interpolation can be used to determine factors for values between those listed in the tables.

**Actual Thermal Hp = 361 \* 0.86 \* 0.95 \* 1.00 \* 1.00 (Factor  $B_V$  N/A due to fan cooling) = 295Hp**

**MAGNAGEAR Parallel Shaft, Double and Triple Reduction**

**Actual Ratio**

Nominal Ratio	Actual Ratio							
	Size 100	Size 150	Size 210	Size 285	Size 390	Size 525	Size 700	Size 920
8.00	8.080	8.146	8.044	7.759	7.754	8.182	8.083	8.155
9.00	9.115	9.189	9.091	8.838	8.719	9.133	9.048	9.039
10.0	10.195	10.278	10.180	9.813	9.579	10.227	10.161	10.172
11.2	11.271	11.363	11.480	10.956	10.847	11.499	11.460	11.340
12.5	12.335	12.435	12.776	12.256	11.824	12.727	12.764	12.776
14.0	14.053	14.167	14.264	13.571	13.543	14.126	14.370	14.211
16.0	15.552	15.678	15.600	15.761	16.476	15.758	15.777	16.046
18.0	17.515	17.657	17.804	17.722	18.325	17.686	17.492	17.888
20.0	20.611	20.737	20.560	20.096	20.526	19.818	19.576	20.297
22.4	22.306	22.487	22.381	23.598	23.191	22.013	22.076	22.200
25.0	25.343	25.500	24.802	25.187	25.405	24.873	25.132	24.624
28.0	28.589	28.766	28.031	28.119	28.767	27.510	27.577	27.235
31.5	31.975	32.174	31.389	31.457	31.359	NA	NA	NA
35.5	35.351	35.571	35.396	34.831	35.917	NA	NA	NA
40.0	38.687	38.928	39.392	40.453	39.519	NA	NA	NA
45.0	44.074	44.348	43.980	45.487	43.697	NA	NA	NA
50.0	48.775	49.078	51.983	51.581	48.601	NA	NA	NA
56.0	54.933	55.274	54.897	55.893	54.439	NA	NA	NA
63.0	64.642	64.915	63.393	63.381	61.507	NA	NA	NA

Note: Shaded area is Triple Reduction.

## MAGNAGEAR Right Angle Triple Reduction

### Actual Ratio

Nominal Ratio	Actual Ratio							
	Size 100	Size 150	Size 210	Size 285	Size 390	Size 525	Size 700	Size 920
12.5	12.409	12.510	12.353	12.698	12.569	12.565	12.412	12.524
14.0	13.998	14.112	13.962	14.409	14.401	14.026	13.895	13.882
16.0	15.657	15.784	15.634	16.414	16.193	15.706	15.605	15.621
18.0	18.230	18.378	17.630	18.224	17.789	17.659	17.600	17.415
20.0	20.390	20.556	19.620	20.346	20.144	19.545	19.603	19.620
22.4	22.543	22.726	22.960	22.761	21.959	21.693	22.068	21.823
25.0	24.670	24.870	25.552	25.308	25.151	25.369	25.910	24.642
28.0	28.105	28.333	28.528	28.254	29.115	28.775	28.859	28.884
31.5	31.103	31.356	31.200	31.607	31.738	31.937	32.488	32.128
35.5	35.030	35.314	35.609	34.998	36.351	35.626	35.669	36.277
40.0	41.221	41.473	41.120	40.646	39.996	39.986	39.547	40.441
45.0	46.655	47.033	46.800	45.705	44.224	44.806	44.258	45.888
50.0	49.770	50.174	50.578	50.091	49.188	49.768	49.911	50.191
56.0	55.572	56.023	55.841	56.550	55.097	56.234	56.821	55.672
63.0	61.832	62.210	61.679	60.289	62.250	62.196	62.348	61.574

# PART NUMBER INDEX



Part No.	Page	Part No.	Page	Part No.	Page	Part No.	Page
272730	24	272804	60	448949	16	449024	16
272731	24	272805	60	448950	16	449025	16
272732	24	448900	16	448951	16	449026	16
272733	24	448901	16	448952	16	449027	16
272734	24	448902	16	448953	16	449028	16
272735	24	448903	16	448954	16	449029	16
272736	24	448904	16	448955	16	449030	16
272737	24	448905	16	448956	16	449032	16
272738	24	448906	16	448957	16	449033	16
272739	24	448907	16	448958	16	449034	16
272740	24	448908	16	448959	16	449037	16
272741	24	448909	16	448960	16	449038	16
272742	24	448910	16	448961	16	449039	16
272743	24	448911	16	448962	16	449040	16
272744	24	448912	16	448963	16	449041	16
272745	24	448913	16	448964	16	449042	16
272746	24	448914	16	448965	16	449043	16
272747	24	299523	74	448966	16	449044	16
272750	33	448900	16	448967	16	449045	16
272751	33	448901	16	448968	16	449046	16
272752	33	448902	16	448969	16	449047	25
272753	33	448903	16	448971	16	449048	25
272754	33	448904	16	448972	16	449049	25
272755	33	448905	16	448973	16	449050	25
272756	33	448906	16	448974	16	449051	25
272757	33	448907	16	448975	16	449052	25
272758	33	448908	16	448976	16	449053	25
272759	33	448909	16	448977	16	449054	25
272760	33	448910	16	448978	16	449055	25
272761	33	448911	16	448979	16	449056	25
272762	33	448912	16	448980	16	449057	25
272763	33	448913	16	448981	16	449058	25
272764	33	448914	16	448982	16	449059	25
272767	42	448915	16	448983	16	449060	25
272768	42	448916	16	448984	16	449061	25
272769	42	448917	16	448985	16	449062	25
272770	42	448918	16	448986	16	449063	25
272771	42	448919	16	448987	16	449064	25
272772	42	448920	16	448988	16	449065	25
272773	42	448921	16	448989	16	449066	25
272774	42	448922	16	448990	16	449067	25
272775	42	448923	16	448991	16	449068	25
272776	42	448924	16	448992	16	449069	25
272777	42	448925	16	448993	16	449070	25
272778	42	448926	16	448994	16	449071	25
272780	51	448927	16	448995	16	449072	25
272781	51	448928	16	448996	16	449073	25
272782	51	448929	16	448998	16	449074	25
272783	51	448930	16	449000	16	449075	25
272784	51	448931	16	449001	16	449076	25
272785	51	448932	16	449002	16	449077	25
272786	51	448933	16	449003	16	449078	25
272787	51	448934	16	449004	16	449079	25
272788	51	448935	16	449006	16	449080	25
272789	51	448936	16	449007	16	449081	25
272790	51	448937	16	449008	16	449082	25
272791	51	448938	16	449009	16	449083	25
272792	51	448939	16	449012	16	449084	25
272795	60	448940	16	449013	16	449085	25
272796	60	448941	16	449014	16	449086	25
272797	60	448942	16	449015	16	449087	25
272798	60	448943	16	449016	16	449088	25
272799	60	448944	16	449017	16	449089	25
272800	60	448945	16	449018	16	449090	25
272801	60	448946	16	449019	16	449091	25
272802	60	448947	16	449020	16	449092	25
272803	60	448948	16	449021	16	449093	25

## PART NUMBER INDEX



Part No.	Page	Part No.	Page	Part No.	Page	Part No.	Page
449094	25	449166	25	449237	34	449311	34
449095	25	449167	25	449238	34	449312	34
449096	25	449170	25	449240	34	449313	34
449097	25	449171	25	449241	34	449314	34
449098	25	449172	25	449242	34	449317	34
449099	25	449173	25	449243	34	449318	34
449100	25	449174	25	449244	34	449319	34
449101	25	449175	25	449245	34	449320	34
449102	25	449176	25	449246	34	449321	34
449103	25	449177	25	449247	34	449322	34
449104	25	449178	25	449248	34	449323	34
449105	25	449179	25	449249	34	449324	34
449106	25	449182	25	449250	34	449325	34
449107	25	449183	25	449251	34	449326	34
449108	25	449184	5	449252	34	449329	34
449110	25	449185	25	449253	34	449330	34
449111	25	449186	25	449254	34	449331	34
449112	25	449187	25	449255	34	449332	34
449113	25	449188	25	449256	34	449333	34
449114	25	449189	25	449257	34	449334	34
449115	25	449190	25	449258	34	449335	34
449116	25	449191	25	449259	34	449336	34
449117	25	449192	34	449260	34	449337	34
449118	25	449193	34	449261	34	449338	34
449119	25	449194	34	449262	34	449339	43
449120	25	449195	34	449263	34	449340	43
449121	25	449196	34	449264	34	449341	43
449122	25	449197	34	449265	34	449342	43
449123	25	449198	34	449267	34	449343	43
449124	25	449199	34	449268	34	449344	43
449125	25	449200	34	449269	34	449345	43
449126	25	449201	34	449270	34	449346	43, 75
449127	25	449202	34	449271	34	449347	43
449128	25	449203	34	449272	34	449348	43
449129	25	449204	34	449273	34	449349	43
449130	25	449205	34	449274	34	449350	43
449131	25	449206	34	449275	34	449351	43
449132	25	449207	34	449276	34	449352	43
449133	25	449208	34	449277	34	449353	43
449134	25	449209	34	449278	34	449354	43
449135	25	449210	34	449279	34	449355	43
449136	25	449211	34	449280	34	449356	43
449137	25	449212	34	449281	34	449357	43
449138	25	449213	34	449282	34	449358	43
449139	25	449214	34	449283	34	449359	43
449140	25	449215	34	449284	34	449360	43
449141	25	449216	34	449285	34	449361	43
449142	25	449217	34	449286	34	449362	43
449143	25	449218	34	449287	34	449363	43
449146	25	449219	34	449288	34	449364	43
449147	25	449220	34	449289	34	449365	43
449148	25	449221	34	449292	34	449366	43
449149	25	449222	34	449293	34	449367	43
449150	25	449223	34	449294	34	449368	43
449151	25	449224	34	449295	34	449369	43
449152	25	449225	34	449296	34	449370	43
449153	25	449226	34	449297	34	449371	43
449154	25	449227	34	449298	34	449372	43
449155	25	449228	34	449299	34	449373	43
449158	25	449229	34	449300	34	449374	43
449159	25	449230	34	449301	34	449375	43
449160	25	449231	34	449305	34	449376	43
449161	25	449232	34	449306	34	449377	43
449162	25	449233	34	449307	34	449378	43
449163	25	449234	34	449308	34	449379	43
449164	25	449235	34	449309	34	449380	43
449165	25	449236	34	449310	34	449381	43

# PART NUMBER INDEX



Part No.	Page	Part No.	Page	Part No.	Page	Part No.	Page
449382	43	449453	43	449526	52	449597	52
449383	43	449454	43	449527	52	449598	52
449384	43	449455	43	449528	52	449599	52
449385	43	449456	43	449529	52	449600	52
449386	43	449457	43	449530	52	449601	52
449387	43	449458	43	449531	52	449602	52
449388	43	449461	43	449532	52	449603	52
449389	43	449462	43	449533	52	449604	52
449390	43	449463	43	449534	52	449607	52
449391	43, 75	449464	43	449535	52	449608	52
449392	43	449465	43	449536	52	449609	52
449393	43	449466	43	449537	52	449610	52
449394	43	449467	43	449538	52	449611	52
449395	43	449468	43	449539	52	449612	52
449396	43	449469	43	449540	52	449613	52
449397	43	449470	43	449541	52	449614	52
449398	43	449473	43	449542	52	449615	52
449399	43	449474	43	449543	52	449616	52
449400	43	449475	43	449544	52	449619	52
449401	43	449476	43	449545	52	449620	52
449402	43	449477	43	449546	52	449621	52
449403	43	449478	43	449547	52	449622	52
449404	43	449479	43	449548	52	449623	52
449405	43	449480	43	449549	52	449624	52
449406	43	449481	43	449550	52	449625	52
449407	43	449482	43	449551	52	449626	52
449408	43	449483	52	449552	52	449627	52
449409	43	449484	52	449553	52	449628	52
449410	43	449485	52	449554	52	449659	61
449411	43	449486	52	449555	52	449660	61
449412	43	449487	52	449556	52	449661	61
449413	43	449488	52	449557	52	449662	61
449414	43	449489	52	449558	52	449663	61
449415	43	449490	52	449559	52	449664	61
449416	43	449491	52	449560	52	449665	61
449417	43	449492	52	449561	52	449666	61
449418	43	449493	52	449562	52	449667	61
449419	43	449494	52	449563	52	449668	61
449420	43	449495	52	449564	52	449669	61
449421	43	449496	52	449565	52	449670	61
449422	43	449497	52	449566	52	449671	61
449423	43	449498	52	449567	52	449672	61
449424	43	449499	52	449568	52	449673	61
449425	43	449500	52	449569	52	449674	61
449426	43	449501	52	449570	52	449675	61
449427	43	449502	52	449571	52	449676	61
449428	43	449504	52	449572	52	449677	61
449429	43	449506	52	449573	52	449678	61
449430	43	449507	52	449574	52	449679	61
449431	43	449508	52	449575	52	449680	61
449432	43	449509	52	449576	52	449681	61
449433	43	449510	52	449577	52	449682	61
449434	43	449511	52	449578	52	449683	61
449437	43	449512	52	449579	52	449684	61
449438	43	449513	52	449580	52	449685	61
449439	43	449514	52	449583	52	449686	61
449440	43	449515	52	449584	52	449687	61
449441	43	449516	52	449585	52	449688	61
449442	43	449517	52	449586	52	449713	61
449443	43	449518	52	449587	52	449714	61
449444	43	449519	52	449588	52	449715	61
449445	43	449520	52	449589	52	449716	61
449446	43	449521	52	449590	52	449717	61
449449	43	449522	52	449591	52	449718	61
449450	43	449523	52	449592	52	449719	61
449451	43	449524	52	449595	52	449720	61
449452	43	449525	52	449596	52	449721	61



## PART NUMBER INDEX



Part No.	Page	Part No.	Page	Part No.	Page	Part No.	Page
449722	6, 61	449888	69	454021	70	454116	51
449723	61	449889	69	454022	70	454117	51
449724	61	449890	69	454023	44	454118	51
449725	61	449891	69	454024	44	454119	51
449726	61	449892	69	454025	44	454120	51
449727	61	449893	69	454026	53	454121	51
449728	61	449894	69	454027	53	454122	51
449729	61	449895	69	454028	53	454123	51
449730	61	449896	69	454029	62	454124	51
449731	61	449897	69	454030	70	454125	51
449732	61	449898	69	454031	70	454126	51
449733	61	449899	69	454032	70	454130	60
449734	61	449900	69	454033	35	454131	60
449735	61	449901	69	454044	35	454132	60
449736	61	449902	69	454045	35	454133	60
449767	65	449903	69	454046	35	454134	60
449768	65	449904	69	454047	26	454135	60
449769	65	449929	69	454048	26	454136	60
449770	65	449930	69	454049	26	454137	60
449771	65	449931	69	454062	24	454138	60
449772	65	449932	69	454063	24	454139	60
449773	65	449933	69	454064	24	454140	60
449774	65	449934	69	454065	24	454198	44
449775	65	449935	69	454066	24	454199	53
449776	65	449936	69	454067	24	499782	65
449777	65	449937	69	454068	24	499783	65
449778	65	449938	69	454069	24	499784	65
449779	65	449939	69	454070	24	499785	65
449780	65	449940	69	454071	24	499786	65
449781	65	449941	69	454072	24	499787	65
449821	65	449942	69	454073	24	499788	65
449822	65	449943	69	454074	24	499789	65
449823	65	449944	69	454075	24	499790	65
449824	65	449945	69	454076	24	499791	65
449825	65	449946	69	454077	24	499792	65
449826	65	449947	69	454078	17, 24	499793	65
449827	65	449948	69	454079	17, 24	499794	65
449828	65	449949	69	454080	17	499795	65
449829	65, 75	449950	69	454081	33	499796	65
449830	65	449951	69	454082	33		
449831	65	449952	69	454083	33		
449832	65	451010	26	454084	33		
449833	65	451526	44, 75	454085	33		
449834	65	452054	66	454086	33		
449835	65	452055	66	454087	33		
449836	65	452097	66, 75	454088	33		
449837	65	452287	17	454089	33		
449838	65	453388	62	454090	33		
449839	65	453389	62	454091	33		
449840	65	453933	26	454092	33		
449841	65	453954	6, 62	454093	33		
449842	65	453959	62	454094	33		
449843	65	454005	17	454095	33		
449844	65	454006	17	454099	42		
449875	69	454007	17	454100	42		
449876	69	454008	26	454101	42		
449877	69	454009	26	454102	42		
449878	69	454011	35	454103	42		
449879	69	454012	35	454104	42		
449880	69	454013	35	454105	42		
449881	69	454014	44	454106	42		
449882	69	454015	44	454107	42		
449883	69	454016	53	454108	42		
449884	69	454017	53	454109	42		
449885	69	454018	53	454110	42		
449886	69	454019	66	454114	51		
449887	69	454020	66	454115	51		



---

**World Headquarters**

P.O. Box 2400, Fort Smith, AR 72902-2400 U.S.A., Ph: (1) 479.646.4711, Fax (1) 479.648.5792, International Fax (1) 479.648.5895

**Baldor - Dodge**

6040 Ponders Court, Greenville, SC 29615-4617 U.S.A., Ph: (1) 864.297.4800, Fax: (1) 864.281.2433

**[www.baldor.com](http://www.baldor.com)**