

# | SNR : The Bearing Housings

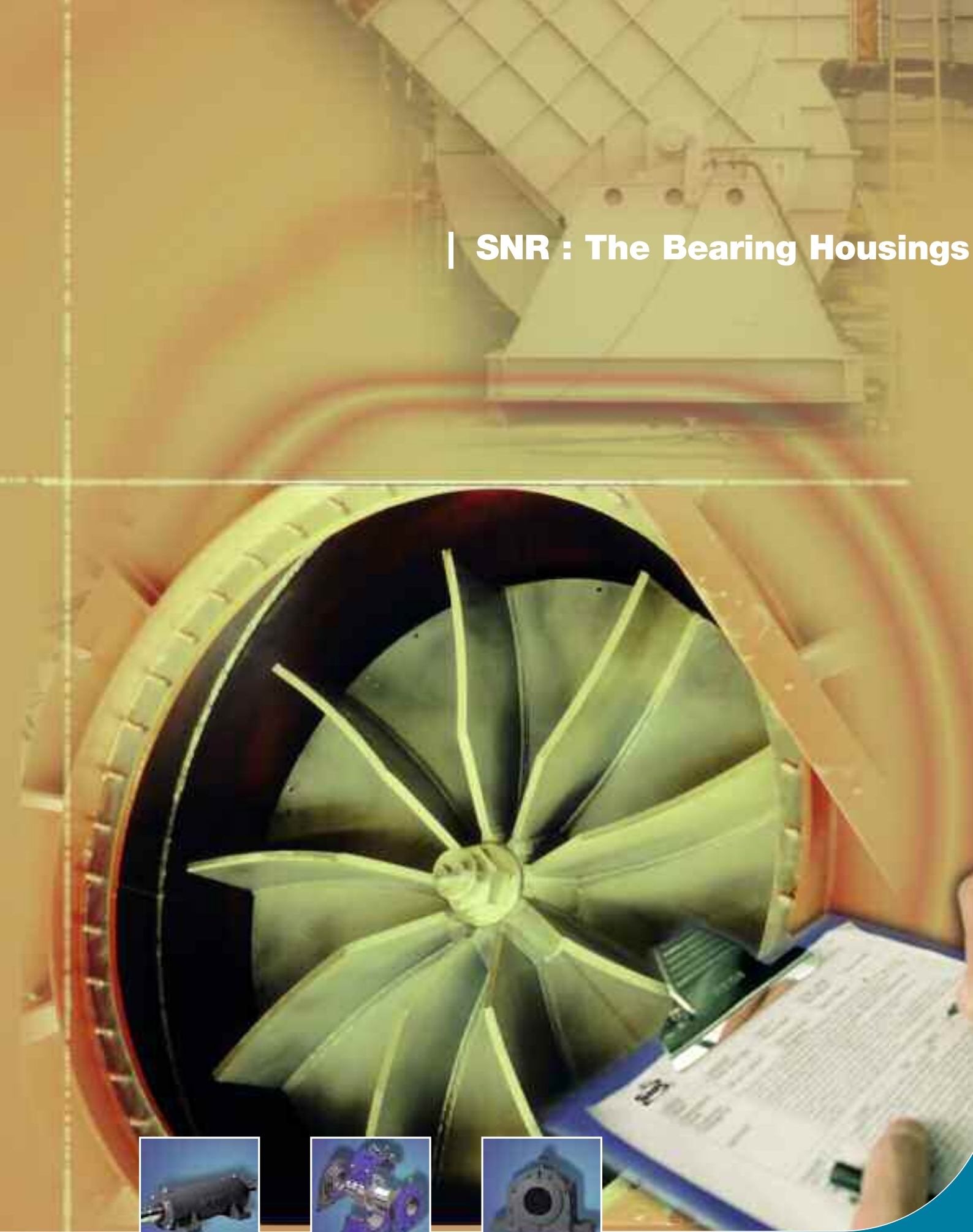

**Industry**





# Contents

	Page		Page
<b>Bearing Housings And Mounting Accessories</b>	<b>2</b>	<b>Flange Bearing Housings 722500</b>	<b>25</b>
Housings	3	Design	25
Bearings	4	Sealing Systems And Lubrication	25
Sealing Systems	6		
Lubrication	8	<b>Flange Bearing Housings F 11200</b>	<b>26</b>
Bearing Clearance	10		
Mounting Tools	12	<b>Plummer Block Housings SD 3100 TS</b>	<b>27</b>
Bearing Arrangement	13	Designs	27
		Sealing system	27
<b>Plummer Block Housings With Oil Lubrication SNOE</b>	<b>14</b>	Lubrication	27
Designs	14	Miscellaneous	27
Sealing Systems	15		
Lubrication	15	<b>Dimension Tables</b>	
Miscellaneous	15	SNOE 200 Plummer Block Housings	28-29
		SNOE 300 Plummer Block Housings	30-31
<b>Mine Car Bearing Housings TVN</b>	<b>16</b>	TVN 200 Mine Car Bearing Housings	32-33
TVN Standard Design	16	TVN 300 Mine Car Bearing Housings	34-35
TVN Housing For High Temperature Applications	16	TVN 6200/6300 Hardening Car Bearing Housings	36-37
		TN 200/300 Plummer Block Housings	38-39
<b>Plummer Block Housings TN</b>	<b>17</b>	ZLG 300 Double Bearing Housings	40-43
		DLG 300 Triple Bearing Housings	44-45
<b>Double And Triple Bearing Housings ZLG/DLG</b>	<b>18</b>	ZLOE 200/300 Double Bearing Housings	46-47
Designs	18	722500 Flange Bearing Housings	48-51
Load	21	F 11200 Flange Bearing Housings	52-53
Lubrication	21	SD 3100 TS Plummer Block Housings	54-57
Sealing System	22		
Miscellaneous	22	<b>Special Solutions</b>	<b>58</b>
		Auxiliary Programme	59
<b>Oil Lubricated Double Bearing Housings ZLOE</b>	<b>23</b>		
Designs	23		
Lubrication	23		
Sealing System	24		
Miscellaneous	24		

## Special note:

Information about our **two-part bearing housings SNC** could be found in the catalogue "The SNC Pillow Block Range For Your Application".

Further on, our catalogue "SNOL Innovation in Performance and Economy" will inform you about the two-part bearing housings SNOL with oil lubrication, which can be sent on request.



## SNR – Bearing Housings

SNR bearing housings are made for all applications where high performance is needed.

SNR offers a wide range of different bearing housings. All offered types are the best choice regarding design, quality and life time.

SNR bearing housings are optimized to fulfil the requirements especially in the following fields of application:

- Ventilator Industry
- Conveyor Systems
- Escalators
- Textile machines
- Mining.....

Especially for the demand in the ventilator industry we extended our range of oil lubricated double bearing housings (ZLOE) with several new models.

All plummer block housings (grease and oil lubricated) are also obtainable fully assembled with shaft.

Our strengths are particularly geared towards the design and production of special housings. In this area too, we have also developed new solutions in close cooperation with our customers.

Our different production options enable us to produce small and bulk volumes at top quality, quickly and inexpensively.

Our customers have been opting for our SNR products for years because the following points are of importance to them:

- All products from a single source
- High quality standard
- Functional details
- High efficiency
- Maintenance and repairs are easy to do and can be done by our customers

The bearing housing design undergoes constant further development. For this reason we reserve the right to introduce at any given time technical modifications to our products which serve to enhance the technical capability.

# Bearing Housings and Mounting accessories

A bearing housing is a module which contains the following components:

- a housing made of cast iron or special materials, 2-part or compact, that can be screwed onto the mounting surface with bolts;
- one or several bearings, which is/are mounted either directly onto the shaft or which is/are attached with the aid of an adapter sleeve;
- a sealing system to protect the bearings in service;
- a device for re-lubrication of the bearings under running conditions.

## Housings

### Housing design

The bearing housing design is available in two basic versions:

- as a 2-part bearing housing with an integrated self-aligning or spherical-roller bearing;
- as a compact unit with an integrated self-aligning or spherical-roller bearing, but also with a bearings or a combination of several other bearings.

Along with this fundamental classification, the SNR bearing housings are also differentiated in terms of plummer block housings, suspended housing, double or triple bearing housings and flange bearing housings.

### Material

The housings are made of grey cast iron as standard. For special applications spheroidal cast iron or cast steel in various qualities are also available. Similarly, various steel materials as well as other application-specific materials can be used.

For special requirements it is also possible to coat the housing surfaces. In such cases please ask us for specific delivery options.

### Painting

All SNR bearing housings are painted in blue (RAL 7031 and RAL 5010 for series SD). All externally-located surfaces are painted, i.e. including the underside and - in part - the housing's bolting surface.

Special paintings are also available on request.

The bearing seat and all other internally-located surfaces are preserved. For oil lubricated bearing housings the housing's free interior surfaces are painted.

### Bearing seat

The bearing seat fittings in the individual housings are geared towards each individual application. Basically however, it is always selected such that axial displacement of the bearing outer race in a floating bearing is possible.

# Bearings

## Bearings with cylindrical bores

Bearings with cylindrical bores are mounted directly onto the shaft. A shaft fit is to be selected that matches the application and bearings used. The bearing itself must however be firmly mounted onto the shaft. An SNR induction heating device should be used (see annex p. 59) to mount the bearing.

Cylindrical bearings require a shaft shoulder as a contact surface within the housing. This in turn means that the diameter of the inlet or outlet bore in the housing generally deviates from the diameter of the bearing used.

The figure below shows a double bearing housing ZLG 300.

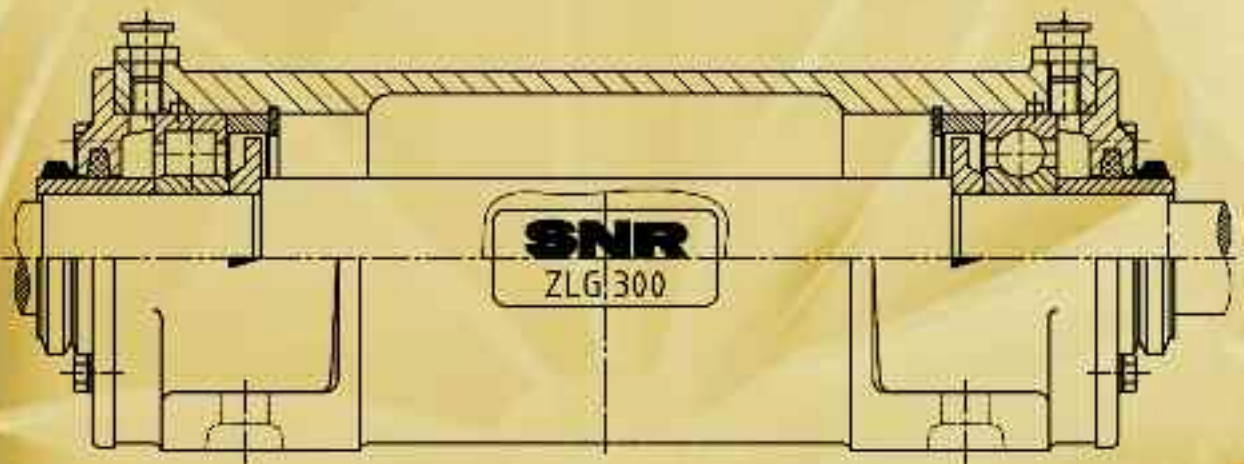

### Bearing with tapered bore

Bearings with a tapered bore are mounted onto the shaft with the aid of an adapter sleeve. Here the tolerance of the shaft may be higher than for bearings with a cylindrical bore. Fundamentally, bright-drawn shafts may be used (fit h7 - h9).

The bearing ring is fastened onto the sleeve by clamping it axially. In doing so the radial bearing clearance after mounting must be adhered to (see SNR mounting card p. 11).

The figure below shows a flange bearing housing.

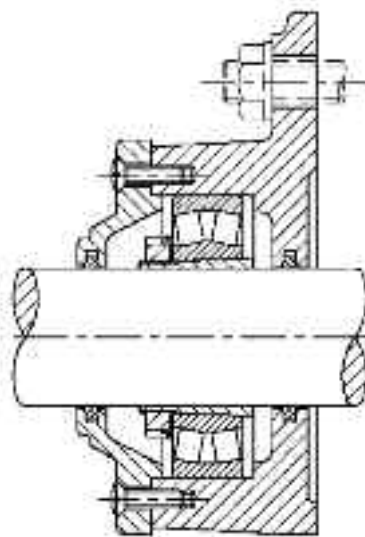

### Bearing clearance

Bearings with tapered bores are made with a greater radial clearance than normal as standard. The designation for this is, for example: 22316 K C3

22316	Spherical roller bearing from 22300 series
K	Tapered bore
C3	bearing clearance

Bearings with cylindrical bores generally have normal clearance (C0). Greater bearing clearance is possible in both instances.

# Sealing Systems

## Felt strip seal

The felt strip, as under DIN 5419, is the reliable standard sealing for many SNR bearing housings. It is easy to fit and can be used for circumferential speeds up to 5 m/s, after a running-in period (approx. 2 hours) up to 15 m/s. Felt seals are suitable for grease lubrication and temperatures of -20 to +100 °C. At higher temperatures up to approx. 300 °C we will be pleased to offer you a selection of special materials.\*

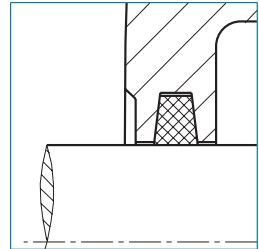

## V-ring seal

Bearing housings which are processed on the front end can be equipped with a V-ring seal. We mainly use V-rings in combination with felt strips. Instead of a felt strip a double lip seal can also be used. They provide additional and inexpensive protection against the ingress of moisture into the bearing housing.

V-rings can be used for circumferential speeds up to 15 m/s. They are made of nitrile rubber (NBR) and suitable for temperatures up to 100 °C. Special materials are available on request for higher temperatures (e.g. Viton).\*

These sealing variants are not only suitable for grease lubricated housings, but also as an auxiliary sealing for oil lubricated bearing housings.

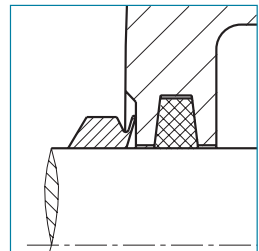

## End cover

If the shaft ends in the housing then this is to be sealed with a cover. End covers are made of grey cast iron and fitted with a felt strip. They are suitable for temperatures up to 100 °C.

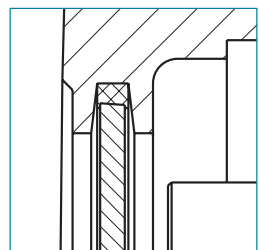

\* For temperatures in excess of 120 °C, please contact an SNR engineer concerning bearing and grease selection.



### Double lip seal

Each SNR bearing housing can accommodate a double lip seal in the ring groove (where available). The design of this seal, which is also made of the NBR (nitrile rubber) material, excels on account of the following sealing properties:

- low increase in friction torque
- optimum protection against foreign particles and moisture
- Improvement in sealing performance through introduction of lubrication grease between the sealing lips when mounting and continuously during operation.

Maximum shaft misalignment:  $\pm 0.5^\circ$

Maximum circumferential speed of shaft: 15m/s

Maximum service temperature:  $-20\text{ }^\circ\text{C}$  to  $+110\text{ }^\circ\text{C}$

For applications up to  $200\text{ }^\circ\text{C}^*$  double lip seals made of Viton or PTFE are available on request.

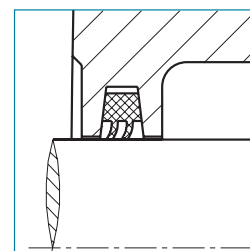

### Labyrinth ring with round cord

Several bearing housings can be equipped with this non-contact sealing variant. The round cord inserted between the labyrinth ring and the shaft serves to lift the labyrinth ring. Any limitation of the circumferential speed with this seal is not necessary.

Maximum shaft misalignment:  $\pm 0.5^\circ$

Maximum temperature:  $200\text{ }^\circ\text{C}^*$

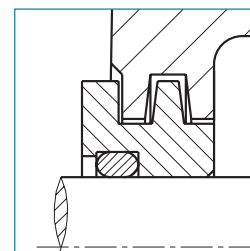

### Application range of individual seals

	Housing									
	SNOE	TVN	TN	ZLG	DLG	ZLOE	722500	F11200	SD 3100	TS
Felt strips		•	•	•	•		•	•		
V-ring	•			•	•	•				
Double lip seal		•		•	•		•			
Labyrinth ring	•					•				•
End cover	•	•					•			•

• = Seal can be used without modifying housing

\* For temperatures in excess of  $120\text{ }^\circ\text{C}$  please contact an SNR engineer concerning bearing and grease selection

# Grease Lubrication

## Grease Lubrication

In the overwhelming majority of bearing housing applications grease lubrication is used for the bearing location. Depending on the service case, the initial grease application when fitting should last for a bearing service life. At higher loads, temperatures or speeds the volume of the lubrication medium loses its lubricating capability in the course of service as a consequence of mechanical load, ageing and increasing contamination.

In this case grease must be added to or changed.

If the service case demands regular lubrication then all SNR bearing housings can be equipped with grease nipples. Several of our housings are already equipped as standard with one or more grease nipples. If this should prove insufficient, we would recommend the use of the SNR grease bushing (see annex). This will ensure that there is continuous re-lubrication of the bearing positions for up to 12 months.

If it is necessary to re-lubricate the bearing housing, there is a risk that too much grease may be left in the interior of the housing. The consequence of this can be an increase in bearing temperature up to overheating of the bearing. To prevent this some SNR bearing housings, in particular at high operating temperatures, have grease regulation discs inserted in them.

The grease regulation disc ensures that any excess grease is removed and thus prevents any excessive grease application to the bearing.

For every re-lubrication process the re-lubrication quantity and compatibility of the new grease with the existing grease must be observed.

Information hereto is available in the following tables.

### Basic oils

	Mineral oil	Diester oil	Polyalkylene glycol oil	Silicon oil (Methyl)	Silicon oil (Phenyl)	Polyvinyl ether oil
Diester oil		+				
Polyalkylene glycol oil	•	+				
Silicon oil (Methyl)	•	•	•			
Silicon oil (Phenyl)	+	+	•	+		
Polyvinyl ether	+	+	•	•	+	
Perfluoropolyether	•	•	•	•	•	•

+ = mixable

• = not mixable

Source: Klüber

## Sealing compound

	Li soap	Na soap	Al complex	Ba complex	Na complex	Bentonite grease
Na soap	●					
Al complex	+	+				
Ba complex	+	+	+			
Na complex	+	+	●	+		
Bentonite grease	+	+	●	+	●	
Polyurea	+	+	+	+	+	+

+ = mixable

● = not mixable

Source: Klüber

The SNR-LUB EP grease is a lithium soap based mineral oil grease and ideally suitable for the following conditions:

- Operating speed of bearing max. 80% of limit speed
- Bearing operating temperature < 100 °C
- Bearing load ratio C/P < 3.5

In the event of divergent operating conditions please contact the SNR engineers. An overview of the general range of SNR-LUB standard greases is available in a special leaflet.

### Oil lubrication

Oil lubrication is much more extensive than grease lubrication. Devices for oil supply and for monitoring the oil level must be provided. In the event of an oil circulating lubrication a pump is also required to generate the oil flow. Apart from this greater effort is required to seal the housing.

We recommend oil lubrication in the following instances, if:

- the operating conditions for a bearing (e. g. high speeds) no longer permit grease lubrication;
- dissipation of the bearing position heat must take place over the lubricant;
- other machine elements, such as, e.g. gears, require

oil lubrication.

Mineral oil based oils are mainly used in the lubrication of bearings.

At particularly high or low temperatures we recommend synthetic based oils.

The viscosity of the lubrication oil is primarily geared towards the prevalent temperature influences. Under normal operating conditions (room temperature < 25 °C) the required viscosity at 40 °C is roughly 60 - 120 mm<sup>2</sup>/S. At higher room temperatures (30 - 50 °C), in small rooms with low air circulation and/or external heating the required viscosity at 40 °C is approx. 120 - 190 mm<sup>2</sup>/S.

A higher viscosity should be selected, if:

- more unfavourable heat dissipation conditions prevail;
- the ratio is  $F_a/F_r > e$ ;
- the operating speed less than 20% of the speed limit.

At speeds that are higher than 70% of the speed limit, a lubrication oil with a lower viscosity should be used.



## | Bearing Clearance

Double-row spherical roller bearings with tapered bore (models 21000 K, 22000 K, 23000 K with concentricity 1:12 and model 24000 K with concentricity 1:30) can be fitted with an adapter sleeve or a withdrawal sleeve, and directly in the event of a tapered shaft. The mounting process causes the inner ring to be expanded and this in turn reduces the radial clearance. The remaining bearing clearance must be checked after mounting is complete.

### How to measure it:

#### 1.) Caution:

One may not perform the measurement on a greased bearing, because the thickness of the lubrication film prevents an accurate measurement from being made.

#### 2.) Tools:

Check the bearing clearance using a feeler gauge. One slides the gauge between the outer ring and rollers. For bearings with a large radial clearance one may not use feeler gauges of more than 0.15 mm, because they are too rigid to be adapted to the spherical bearing surface. Here one should use several smaller tabs together to achieve the desired thickness.

### Checking clearance before mounting:

Place the bearing in a vertical position, so that at both sides the rollers abut with the closing edges of the outer ring. Turn the inner ring by hand and apply a radial load in the vertical direction. Determine the theoretical radial clearance with the aid of the table. Slide the gauge between the relieved, i.e. the upper rollers and the outer ring. Now one has to start checking with the smallest gauge between the rollers and the outer ring.

The thickness of the gauge is now increased in increments. The radial clearance lies between the last gauge, which can be moved between the roller and outer ring, and the gauge, which is stuck between the roller and the outer ring.

### Checking clearance after mounting:

To determine the remaining clearance proceed as described under the heading "Checking clearance before mounting". Check the reduction of the clearance after mounting in the table below and determine with the aid of the previously described measures, whether the minimum or maximum value has been maintained.



## Radial clearance reduction when installing SNR spherical roller bearings with tapered bore

Nominal dimension of bearing bore	Radial clearance before installation Bearing clearance group						Reduction of radial clearance	Displacement on tapered diameter 1:12				Displacement on tapered diameter 1:30				Check value for smallest radial clearance after installation Clearance group							
	d over up to [mm]		normal [mm]		C3 [mm]			C4 [mm]		min [mm]		max [mm]		Shaft [mm]		Sleeve [mm]		Shaft [mm]		Sleeve [mm]		normal	C3
30	40	0,035	0,05	0,05	0,065	0,065	0,085	0,02	0,025	0,35	0,4	0,35	0,45								0,015	0,025	0,04
40	50	0,045	0,06	0,06	0,08	0,08	0,1	0,025	0,03	0,4	0,45	0,45	0,5								0,02	0,03	0,05
50	65	0,055	0,075	0,075	0,095	0,095	0,12	0,03	0,04	0,45	0,6	0,5	0,7								0,025	0,035	0,055
65	80	0,07	0,095	0,095	0,12	0,12	0,15	0,04	0,05	0,6	0,75	0,7	0,85								0,025	0,04	0,07
80	100	0,08	0,11	0,11	0,14	0,14	0,18	0,045	0,06	0,7	0,9	0,75	1,0	1,7	2,2	1,8	2,4				0,035	0,05	0,08
100	120	0,1	0,135	0,135	0,17	0,17	0,22	0,05	0,07	0,7	1,1	0,8	1,2	1,9	2,7	2,0	2,8				0,05	0,065	0,1
120	140	0,12	0,16	0,16	0,2	0,2	0,26	0,065	0,09	1,1	1,4	1,2	1,5	2,7	3,5	2,8	3,6				0,055	0,08	0,11
140	160	0,13	0,18	0,18	0,23	0,23	0,3	0,075	0,1	1,2	1,6	1,3	1,7	3,0	4,0	3,1	4,2				0,055	0,09	0,13
160	180	0,14	0,2	0,2	0,26	0,26	0,34	0,08	0,11	1,3	1,7	1,4	1,9	3,2	4,2	3,3	4,6				0,06	0,1	0,15
180	200	0,16	0,22	0,22	0,29	0,29	0,37	0,09	0,13	1,4	2,0	1,5	2,2	3,5	4,5	3,6	5,0				0,07	0,1	0,16
200	225	0,18	0,25	0,25	0,32	0,32	0,41	0,1	0,14	1,6	2,2	1,7	2,4	4,0	5,5	4,2	5,7				0,08	0,12	0,18
225	250	0,2	0,27	0,27	0,35	0,35	0,45	0,11	0,15	1,7	2,4	1,8	2,6	4,2	6,0	4,6	6,2				0,09	0,13	0,2
250	280	0,22	0,3	0,3	0,39	0,39	0,49	0,12	0,17	1,9	2,6	2,0	2,9	4,7	6,7	4,8	6,9				0,1	0,14	0,22
280	315	0,24	0,33	0,33	0,43	0,43	0,54	0,13	0,19	2,0	3,0	2,2	3,2	5,0	7,5	5,2	7,7				0,11	0,15	0,24
315	355	0,27	0,36	0,36	0,47	0,47	0,59	0,15	0,21	2,4	3,4	2,6	3,6	6,0	8,2	6,2	8,4				0,12	0,17	0,26
355	400	0,3	0,4	0,4	0,52	0,52	0,65	0,17	0,23	2,6	3,6	2,9	3,9	6,5	9,0	6,8	9,2				0,13	0,19	0,29
400	450	0,33	0,44	0,44	0,57	0,57	0,72	0,2	0,26	3,1	4,1	3,4	4,4	7,7	10,0	8,0	10,4				0,13	0,2	0,31
450	500	0,37	0,49	0,49	0,63	0,63	0,79	0,21	0,28	3,3	4,4	3,6	4,8	8,2	11,0	8,4	11,2				0,16	0,23	0,35
500	560	0,41	0,54	0,54	0,68	0,68	0,87	0,24	0,32	3,7	5,0	4,1	5,4	9,2	12,5	9,6	12,8				0,17	0,25	0,36
560	630	0,46	0,6	0,6	0,76	0,76	0,98	0,26	0,35	4,0	5,4	4,4	5,9	10,0	13,5	10,4	14,0				0,2	0,29	0,41
630	710	0,51	0,67	0,67	0,85	0,85	1,09	0,3	0,4	4,6	6,2	5,1	6,8	11,5	15,5	12,0	16,0				0,21	0,31	0,45
710	800	0,57	0,75	0,75	0,96	0,96	1,22	0,34	0,45	5,3	7,0	5,8	7,6	13,3	17,5	13,6	18,0				0,23	0,35	0,51
800	900	0,64	0,84	0,84	1,07	1,07	1,37	0,37	0,5	5,7	7,8	6,3	8,5	14,3	19,5	14,8	20,0				0,27	0,39	0,57
900	1000	0,71	0,93	0,93	1,19	1,19	1,52	0,41	0,55	6,3	8,5	7,0	9,4	15,8	21,0	16,4	22,0				0,3	0,43	0,64
1000	1120	0,78	1,02	1,02	1,3	1,3	1,65	0,45	0,6	6,8	9,0	7,6	10,2	17,0	23,0	18,0	24,0				0,32	0,48	0,7
1120	1250	0,86	1,12	1,12	1,42	1,42	1,8	0,49	0,65	7,4	9,8	8,3	11,0	18,5	25,0	19,6	26,0				0,34	0,54	0,77

# Maintenance: installation-removal Quality, for a longer service life

*Know-how and cleanliness are essential factors for bearing installation and removal.  
SNR proposes suitable tools, tailored to your needs to optimize bearing service life.*

a - Induction heating devices: Fast Therm 20/35/150/300/600/1000

b - Installation kit

c - Wrench for standard and precision locknuts

d - Hydraulic extractor, 10T

e - Kevlar<sup>®</sup>, heat-resistant gloves



a



b



c



d



e



*You will find all our products in*

*SNR's Maintenance catalogue: 64 pages of solutions.*

- *Lubrication*
- *Installation & removal*
- *Measurement & monitoring*
- *Vibratory analysis, training, ...*

## | Before Mounting

The bearings, adapter sleeves, locating rings and grease regulation discs are not to be removed from their original packaging until immediately before they are mounted. Do not wash the bearings!

## | Mating Structure

The flatness tolerance of the bolting surface of our bearing housing should be IT7, relative to the housing foot diagonal.

For surface roughness we recommend  $Rz \leq 100 \mu\text{m}$ .

## | Mounting Bearings On The Shaft

### **Bearings with cylindrical bores**

One makes a differentiation between mounting in a warm or cold condition. The type of mounting process is geared towards the bearing sizes, whereby bearings with small diameters should be cold and bearings with large diameters should be warm when mounted. The use of an [SNR induction heating device](#)\* enables the bearing to be heated to the prescribed temperature, in order to mount it easily onto the shaft. When mounting cold a hydraulic press or other aid should be used. When mounting with a mounting sleeve and hammer make sure that the load is always applied to the fixed bearing ring. The grease regulation disc must be mounted onto the shaft before the bearing is mounted. After mounting the bearing, check whether the shaft shoulders contact each other. Finally the bearings are fixed in accordance with the installation drawing in an axial direction.

### **Bearing with tapered bore (adapter sleeve attachment)**

Bearing radial clearance is to be checked using feeler gauges (to do so use SNR- feeler gauges + mounting card). Slide the bearing onto the sleeve and then fit the lock washer and nut. Do not yet tighten the nut. Slide the pre-mounted bearing with the sleeve into the desired position on the shaft. The floating bearing should always be in the centre of the housing. To check this one can place the shaft provisionally into the housing. Now the adapter sleeve can be tightened with the aid of a hook spanner. While tightening the reduction in clearance in the bearing must be constantly checked with the aid of a feeler gauge. The specified clearance reduction is available in the SNR mounting card or you can read off the necessary displacement. Self-aligning ball bearings are clamped until the clearance is almost zero and the outer ring can still be swivelled by hand. The nut of the adapter sleeve is determined by bending a tab of the lock washer in a groove of the nut. The bearings are then filled with the required quantity of grease.

## | Operating And Maintenance Instructions

Comprehensive operating and maintenance instructions for SNR bearing housing is available in several languages. Im Bedarfsfall senden wir Ihnen diese gerne zu.

\* Our induction heating devices are available in our Maintenance catalogue as from page 45.

## SNOE Plummer Block Housings (oil version)

Oil version plummer block housings of models SNOE 200 and SNOE 300 are mounted with spherical roller bearings with cylindrical bore of the 22200 or 22300 series.

Oil lubricated plummer block housings are suitable for high speeds and are, e.g. used in the ventilator industry.

### | Designs

SNR supplies these plummer block housings in design A with a sealed cover for the shaft ends and in design B with open cover for through shafts. Plummer block housings can be ordered as floating bearing (AL, BL) and locating bearing (AF, BF). The floating bearing function is safeguarded through the housing adaptation (G6). The bearing is axially fastened in place by the cover in the locating bearing design.

The housing body is two-piece for easier mounting; the cover and labyrinth rings are single piece.





## | Sealing Systems

The gap between the housing and the cover is sealed with a flat seal. The sealing surfaces are also coated with a sealing compound. A labyrinth ring is used for sealing between the shaft and cover, which enables the shaft to be misaligned by up to 0.25°. Blocking grease chambers are integrated into the open covers as additional seals; they can be subsequently lubricated by way of a button head lubricating nipple DIN 3404 M10x1.

## | Lubrication

The housings are filled with oil by way of a filling bore in the housing cap. A vent screw is then mounted into this bore. When in service oil is distributed by way of a ring oiler, which carries the oil from the oil sump in the housing base. The oil level in the housing can be read off on an oil level indicator mounted to the cover.



## | Miscellaneous

The ring nut in the housing cap serves to ease handling. It may only be loaded by the weight of the housing and bearing together. Mating threads are available for SPM measuring nipples. Naturally, additional bores, e.g. for temperature sensors can also be fitted by us if requested.

We will also be glad to supply you with SNOE plumber block housings as complete unit with shaft. Provided that you notify us of the dimensions of your mating structure. Example, see Page 58.

# Mine Car Bearing Housings TVN

## | TVN Standard Design

SNR mine car bearing housing models TVN 200 and TVN 300 are equipped with self-aligning ball bearings from the 1200, 1300 series or deep groove ball bearings from the 6200, 6300 series. They are primarily used as journal bearing sets for mine cars.

SNR supplies these plummer block housings in design A with a sealed cover for the shaft ends and in design B with open cover for through shafts. Both designs are available as floating and locating bearings.

This bearing unit is frequently used in rough environments. To provide the bearing here with special protection two felt strips are fitted into the cover and the housing. The housing can accommodate a shaft misalignment of up to 0.5°.

## | TVN Housings For High Temperature Applications

SNR provides these housings as floating bearings only in design A with sealed cover. When used in high temperatures a special sealing system is required. It consists of two hot steam packagings located between the housing and shaft and an additional flat seal between the cover and housing.

Basically, there are two fields of application:

1. Sand-lime brick industry (environment: hot and moist)
2. Other high temperature applications, e.g. clinker hardening plants (environment: hot and dry)

For deployment in sand-lime brick hardening shops the SNR deep groove ball bearings from the 6200 F605 and 6300 F605 series are used. For sealing and lubrication the special lubricant **HOSTAFLON TF 1645** is used. We recommend filling the entire housing. The lubricant penetrates the smallest gaps in the bearing and forms a protective lubricating film there, which simultaneously protects the housing from inside against any moisture ingress.

For dry high temperature applications SNR deep groove ball bearings from the 6200 F600 and 6300 F600 series are used; they can be recognised by the black surface. The **KLÜBER WOLFRASYN ULAF** paste is used here as lubricant. The bearings must be fully greased before they are mounted. In doing so care must be taken to ensure that sufficient lubricant is applied between the raceways and the balls. Once the carrier fluid evaporates all that is left on the bearing is a powder. For these bearings it is possible to use deep groove ball bearings from the 6200 F604 and 6300 F604 series. These bearings are covered on both sides and greased in advance with **KLÜBER WOLFRASYN ULAF**.

## | Plummer Block Housings TN 200

Model TN 200 plummer block housings are single-piece housings and are mounted with self-aligning ball bearings with a wide inner ring. They are primarily used in agricultural engineering. The housings are equipped with covers made of grey cast iron and sealed with felt rings. For re-lubrication purposes an M10x1 threaded bore is provided, which is closed at delivery with a screw plug.



# Double And Triple Bearing Housings

Double bearing and triple bearing housings are mainly developed in our company for the mounting of industrial ventilators. Because these bearing units can be mounted simply and have an extremely accurate guide. They have also become established in other industrial branches. At this point only a few application examples are mentioned: large sawing installations, conveying systems and textile machines.

## Designs

Depending on the load concerned we have developed the following standard variants for you:

### Designs AA - AF in a brief overview

Type of load	Designs					
	AA	AB	AC	AD	AE	AF
Radial load	+/+	++/+	++/+	++/++	++/++	+/++
Left/right bearing position						
Axial load – one side	+	+	+	+	+	+
Axial load – both sides	0*	+	-	+	+	+
Speed	++	+	+	+	+	++

0\*: Axial loads on both sides are possible, but only without using the spring washer.

### Design AA

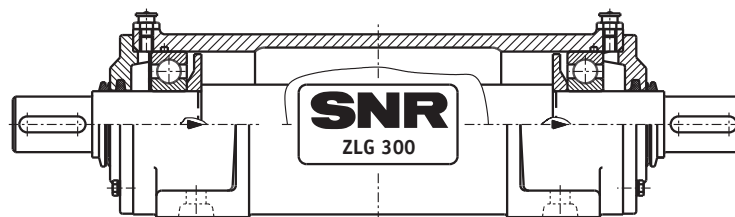

Deep groove ball bearing / Deep groove ball bearing

(AA)

High speeds and radial loads are particularly well absorbed here, whereby the axial loads must act from one direction. The spring washer ensures low-noise and smooth operation, something that is particularly valuable at high speeds. If alternating axial loads can be expected then spring washers cannot be used. Please note that in this case the mounting specifications and shaft dimensions change.





**Design AB**

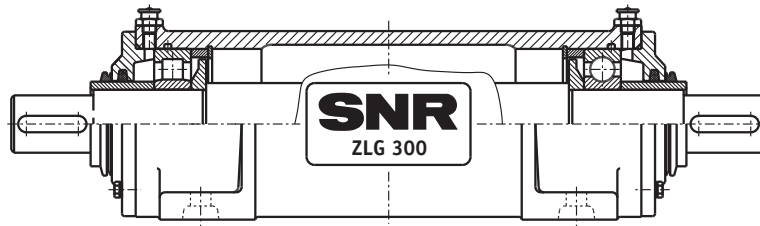

Cylindrical roller bearing NU / Deep groove ball bearing (AB)

This type of mounting absorbs axial loads from both directions and high radial loads on one side.

**Design AC**

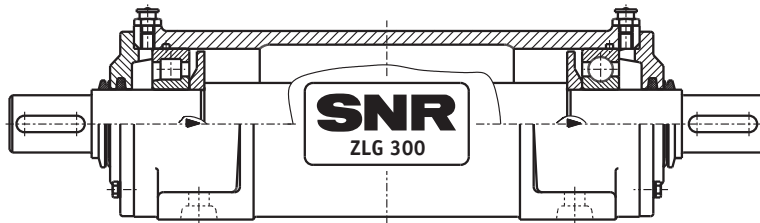

Cylindrical roller bearing NJ / Deep groove ball bearing (AC)

A bearing unit in this design is used wherever high radial and axial loads from one direction are given. In contrast to design AB the bearings are not axially clamped here. Mounting is also easier because there is no need for retaining rings inside the housing.

**Design AD**

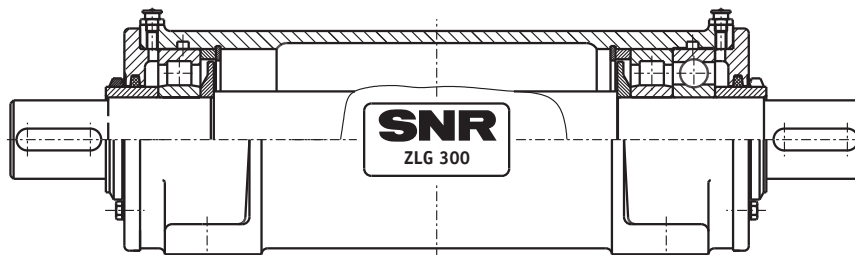

Cylindrical roller bearing / Cylindrical roller bearing, deep groove ball bearing (AD)

Bearing units of this type can absorb significant radial and axial loads from all directions.



### Design AE

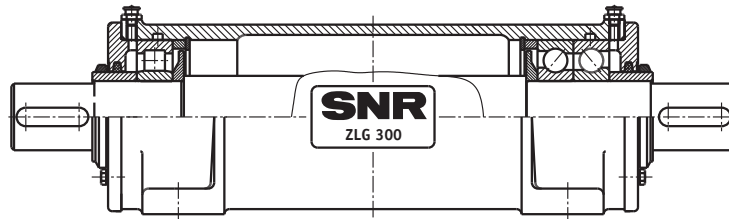

Cylindrical roller bearing / 2x angular contact ball bearings

(AE)

These units are suitable for large axial loads from both directions. They are also able to absorb high radial loads.

### Design AF

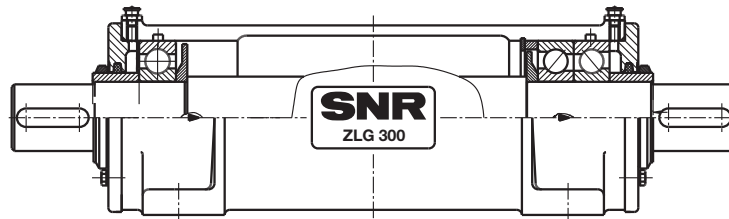

Deep groove ball bearing / 2x angular contact ball bearings

(AF)

This design type absorbs high axial loads from one direction, while through the deep groove ball bearing on the one side low to medium radial loads are absorbed.

Size	Initial greasing per bearing position	Re-lubrication quantity per bearing
	[cm <sup>3</sup> ]	[cm <sup>3</sup> ]
ZLG 306	46	20
ZLG 307	85	26
ZLG 308	103	36
ZLG 309	133	50
ZLG 310	168	67
ZLG 311	224	86
ZLG 312	243	108
ZLG 313	333	132
ZLG 314	411	160
ZLG 315	429	192
ZLG 316	590	227
ZLG 317	577	271
ZLG 318	692	316
ZLG 319	734	308
ZLG 320	954	368
ZLG 322	749	466
ZLG 324	966	657

Size	Initial greasing per bearing position**	Re-lubrication quantity per bearing*
	[cm <sup>3</sup> ]	[cm <sup>3</sup> ]
DLG 314	411	160
DLG 315	429	192
DLG 316	590	227
DLG 317	577	271
DLG 318	692	316
DLG 319	734	308
DLG 320	954	368
DLG 322	749	466
DLG 324	966	657

\* For triple-bearing housings note that on one side two bearings must be greased.

\*\* Triple bearing housings are populated on one side with two bearings, for this reason make sure that at this position the quantity for the initial greasing is increased by the quantity required for re-lubrication.

## | Load

The cast-in arrows on the housing side indicate the direction in which axial loads must act in the event that a bearing unit can only have axial loads applied to it on one side.

## | Lubrication

All housings are given 2 button head lubricating nipples DIN 3404-A M10x1, to ensure both bearing positions enjoy optimum re-lubrication. All double and triple bearing housings are equipped with grease regulation discs to regulate the grease quantity at the bearing positions.

### Re-lubrication interval:

In the standard case we recommend re-lubrication of the above-mentioned quantities every 3,000 operating hours (at least 2x a year).

### Grease type:

SNR LUB-EP or Shell Alvania R3

### depending on application:

For applications outside the standard area please ask an SNR engineer for a suitable grease type.



## | Sealing System

Our standard versions are supplied with felt strips and V-rings. This sealing combination acts against any grease escaping while simultaneously preventing any ingress of contamination. For other sealing options such as, e.g. labyrinth ring, GAMMA ring, lamellar rings etc., we will also be glad to provide you with technical assistance.

## | Miscellaneous

Double and triple bearing housings are also available as special versions in small quantities. It is also possible to make bores for various measurement devices.

For a bearing seat fit on the shaft for deep groove ball bearings and cylindrical roller bearings we recommend:

- up to 100 mm=> k6
- over 100 mm=> m6

For angular contact ball bearings a fit of j5 is specified.

The speed limit is determined in each case by the bearings used!

If you notify us the dimensions of the mating structure for your design, we will be glad to supply you with double or triple bearing housings fully mounted, pre-lubricated and with a corresponding shaft. That means that you have the advantage of getting the complete unit from one supplier only.



# Oil Lubricated Double Bearing Housing (ZLOE)

For a double bearing housing such as model ZLOE two bearings are in a single-piece housing body as for ZLG. This means that the alignment of individual plummer block housings to each other is no longer required, which in turn rules out any misalignment. Various bearing options are possible. The two most frequent variants are described below.

## Designs

### a) ZLOE...A

This design is equipped with two deep groove ball bearings from the 6200 or 6300 series in supporting bearing arrangement (floating bearing).

Next to radial loads, axial loads can only be absorbed in one direction. The additionally installed spring washer serves to ensure that operation is low noise and smooth, something that is particularly valuable at high speeds. For axial loads on both sides or alternating the bearing opposite the spring washer is secured axially. This then makes it a locating bearing.

Because of its smooth running, in this case the floating bearing is also axially pre-clamped using a spring washer.

### b) ZLOE...B

For this version a deep groove ball bearing from 6200 or 6300 series is installed on the locating bearing side and a cylindrical roller bearing NU 200 or NU 300 installed on the floating bearing side. With this higher radial loads can be absorbed on one side.

### c) Additional designs

Next to these two bearing combinations ZLOE housings, as with the ZLG housing, can be equipped with various additional arrangements of deep groove ball bearings, cylindrical roller bearings, four-point bearing or angular contact ball bearings. A bearing seat has been widened, to enable two bearings (e.g. an O-arrangement of two angular contact ball bearings) to be accommodated.

## Lubrication

ZLOE bearing housings are lubricated with oil, which is distributed by the rotation of the bearings in the raceways. The housing is basically specified for oil bath lubrication. For more stringent requirements it can also be operated using oil circulation or oil spray lubrication. An oil level indicator in the centre of the housing enables the oil level to be read off at any given time when in operation.



## | Sealing System

The gap between the housing and the cover is sealed with a flat seal. A labyrinth with threaded seal (in the cover) in the opposite direction to rotation prevents oil escaping between the cover and the shaft.

## | Miscellaneous

The housing is fastened on the clamping surface using four foot fastening bolts. The housing foot is equipped with punch marks; these enable the housing to be located after mounting with the aid of straight pins.

The housing body and the cover are made as standard from grey cast iron. Depending on the service case they can also be made from other materials. Several models are available in spheroidal graphite iron.

Located at each bearing position are three bores for connection of various measurement and monitoring devices. These bores are sealed in delivery condition with plastic plugs.



## | Flange Bearing Housings 722500

Flange bearing housings, model 722500 have been developed for a wide range of applications. Depending on the application field they are mounted with self-aligning ball bearings from the 1200, 2200 series or spherical roller bearings from the 22200 series (each with tapered bore). The bearings are fastened to the shaft using adapter sleeves.

### | Design

SNR supplies these flange bearing housings in design A with a sealed cover for the shaft ends and in design B with open cover for through shafts. The housings can be ordered as floating bearings and as locating bearings. The locating bearing design is equipped with one or two locating rings. The housing sizes 722505 to 722513 are available as 3-bolt flange housings, sizes 722515 to 722522 as 4-bolt flange housings.

### | Sealing Systems And Lubrication

To prevent the bearing against external contamination and to trap escaping grease, a felt ring or double-lip seals are fitted to the cover and in the housing.

Max. shaft misalignment:  $\pm 0.5^\circ$

Housings are designed for grease lubrication.

An M10x1 threaded hole is provided for re-lubrication purposes.



## Flange Bearing Housings F 11200

Flange bearing housings, model F 11200 are mounted with self-aligning ball bearings with widened inner ring from the 11200 series. They are mainly used for mountings (e.g. in textile machine manufacturing), where simple handling is required. The housing is sealed using two felt rings. For re-lubrication of the bearing the housing comes with an M10x1 threaded hole. The bearing seat in the housing is manufactured to a tolerance of H8. To prevent any contact between the mating parts and the housing, the inner ring of the self-aligning ball bearings protrudes by 1 mm on the cover side.



# I Plummer Block Housings SD 3100 TS

Plummer block housings, model SD 3100 TS are two-piece plummer blocks for shaft diameters of 150 mm to 400 mm. They are mounted with spherical roller bearings with tapered bore from the 23100 series. The bearings are fastened on the shaft using adapter sleeves. These housings are used in heavy machine construction, e.g. conveyor systems, conveyor screws, roll crushers etc.

## | Designs

SNR supplies these housings in design A with an end cover for the shaft ends and in design B with labyrinth rings on both sides for through shafts. The housings are available as floating and locating bearings. Up to a shaft diameter  $d = 180$  mm locating rings are used on both sides of the bearing for the locating bearing design. For larger housings the axial fastening takes place in the housing itself.

## | Sealing System

Plummer block housings are sealed using triple labyrinth rings. For this non-contact seal a round cord is inserted between the ring and shaft to lift it. Using the round cord means that the circumferential speed needn't be limited. Shaft misalignments of  $\pm 0.25^\circ$  relative to the housing are permissible.

## | Lubrication

The plummer block housings are designed for grease lubrication and they can be re-lubricated by means of a button head lubricating nipple DIN 3404 G 1/4", which is mounted at the top of the housing.

## | Miscellaneous

The ring bolt in the housing cap serves to ease handling. It may only be loaded by the weight of the housing and bearing together.





# Plummer Block Housings SNOE 200

for bearings with cylindrical bore,  
specified for oil lubrication

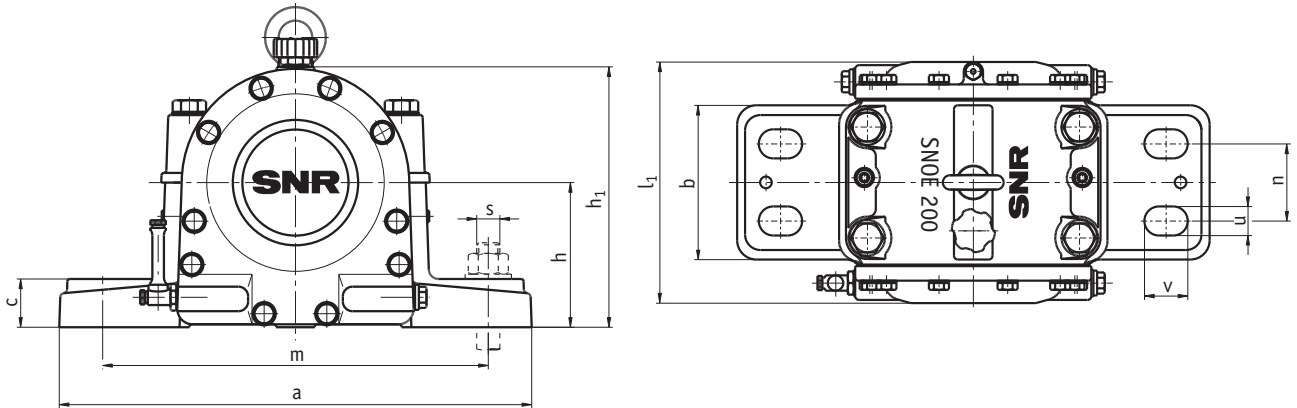

\* = Radius of recess according to DIN 509 Form E

d	d <sub>1</sub>	d <sub>2</sub>	d <sub>3</sub>	a	b	c	g	g <sub>1</sub>	h	h <sub>1</sub>	l	l <sub>1</sub>	m	n	u	v	s	r*
																		max.
85	90	-	M85x2	410	150	48	62	37	135	240	160	225	340	80	25	35	M20	1,0
		82						-										
90	95	-	M90x2	410	150	48	61	40	135	245	160	225	340	80	25	35	M20	1,0
		87						-										
95	100	-	M95x2	490	160	50	67	42	150	270	170	250	400	80	30	45	M24	1,0
		92						-										
100	110	-	M100x2	490	160	50	60	45	150	270	170	250	400	80	30	45	M24	2,5
		97						-										
110	116	-	M110x2	510	165	50	70	49	165	300	175	250	420	80	30	45	M24	1,6
		107						-										
120	126	-	M120x2	550	165	55	72	52	175	320	175	250	440	80	36	50	M30	1,6
		117						-										
130	136	-	M130x2	570	175	65	77	56	190	345	185	260	460	90	36	50	M30	1,6
		127						-										
140	150	-	M140x2	570	175	65	73	58	190	355	180	260	460	100	36	50	M30	2,5
		137						-										
150	156	-	M150x2	660	190	70	82	64	220	395	200	275	530	100	42	60	M36	1,6
		147						-										
160	170	-	M160x3	660	200	70	80	70	220	400	210	290	530	110	42	60	M36	2,5
		155						-										
170	176	-	M170x3	710	200	85	90	73	260	460	210	300	580	110	42	60	M36	1,6
		165						-										
180	190	-	M180x3	710	200	85	90	75	260	465	210	300	580	110	42	60	M36	2,5
		175						-										
190	196	-	M190x3	820	240	90	95	81	270	485	250	350	670	130	48	70	M42	1,6
		185						-										
200	210	-	M200x3	830	240	90	100	83	280	510	260	360	670	130	48	70	M42	2,5
		195						-										
220	230	-	TR220x4	880	240	105	108	92	310	565	280	380	720	130	48	70	M42	2,5
		212						-										
240	260	-	TR240x4	980	280	120	120	100	340	615	300	400	820	165	48	70	M42	4,0
		235						-										

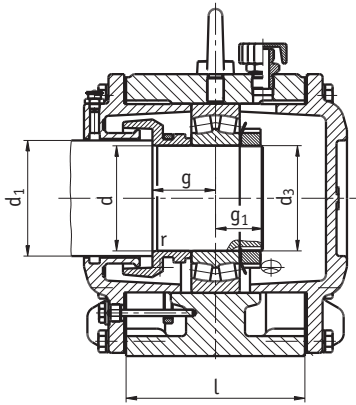

Design:  
AF locating bearing

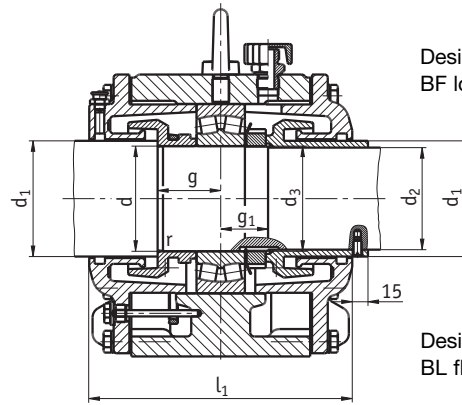

Design:  
BF locating bearing

Design:  
AL locating bearing

Design:  
BL floating bearing

**Axial displacement in case of floating bearing arrangement**

SNOE 214 ... 238	10 mm
SNOE 240 ... 248	15 mm

We will also be glad to supply you with SNOE plummer block housings as complete unit with shaft. Provided that you notify us of the dimensions of your mating structure. Example, see page 58.

code number locating bearing	code number floating bearing	bearing	mounting parts lock nut	lock washer	oil level [mm]	oil quantity for initial fill approx. l	housing weight approx. kg
SNOE 217 AF	SNOE 217 AL	22217	KM 17	MB 17	50-65	1,4	45
SNOE 217 BF	SNOE 217 BL						
SNOE 218 AF	SNOE 218 AL	22218	KM 18	MB 18	45-60	1,5	47
SNOE 218 BF	SNOE 218 BL						
SNOE 219 AF	SNOE 219 AL	22219	KM 19	MB 19	55-70	1,6	60
SNOE 219 BF	SNOE 219 BL						
SNOE 220 AF	SNOE 220 AL	22220	KM 20	MB 20	50-65	1,7	67
SNOE 220 BF	SNOE 220 BL						
SNOE 222 AF	SNOE 222 AL	22222	KM 22	MB 22	50-70	2,1	74
SNOE 222 BF	SNOE 222 BL						
SNOE 224 AF	SNOE 224 AL	22224	KM 24	MB 24	50-70	2,3	80
SNOE 224 BF	SNOE 224 BL						
SNOE 226 AF	SNOE 226 AL	22226	KM 26	MB 26	55-75	2,3	93
SNOE 226 BF	SNOE 226 BL						
SNOE 228 AF	SNOE 228 AL	22228	KM 28	MB 28	55-70	3,7	100
SNOE 228 BF	SNOE 228 BL						
SNOE 230 AF	SNOE 230 AL	22230	KM 30	MB 30	65-90	4,2	125
SNOE 230 BF	SNOE 230 BL						
SNOE 232 AF	SNOE 232 AL	22232	KM 32	MB 32	60-80	4,7	136
SNOE 232 BF	SNOE 232 BL						
SNOE 234 AF	SNOE 234 AL	22234	KM 34	MB 34	90-105	6,0	160
SNOE 234 BF	SNOE 234 BL						
SNOE 236 AF	SNOE 236 AL	22236	KM 36	MB 36	75-110	6,0	200
SNOE 236 BF	SNOE 236 BL						
SNOE 238 AF	SNOE 238 AL	22238	KM 38	MB 38	70-100	7,2	230
SNOE 238 BF	SNOE 238 BL						
SNOE 240 AF	SNOE 240 AL	22240	KM 40	MB 40	75-100	7,2	250
SNOE 240 BF	SNOE 240 BL						
SNOE 244 AF	SNOE 244 AL	22244	HM 44 T	MB 44	80-110	8,2	310
SNOE 244 BF	SNOE 244 BL						
SNOE 248 AF	SNOE 248 AL	22248	HM 48 T	MB 48	100-125	8,4	385
SNOE 248 BF	SNOE 248 BL						

# Plummer Block Housings SNOE 300

for bearings with cylindrical bore,  
specified for oil lubrication

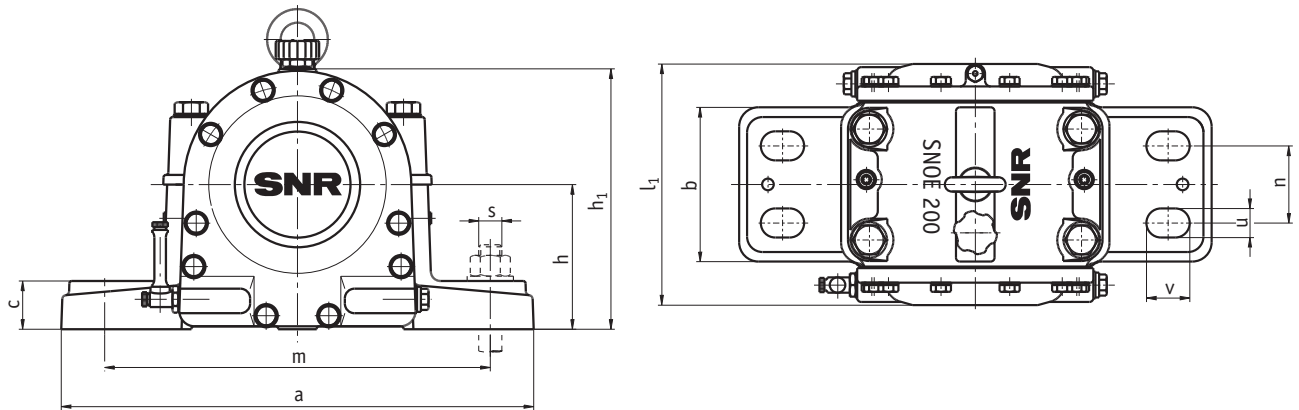

\* = Radius of recess according to DIN 509 Form E

d	d <sub>1</sub>	d <sub>2</sub>	d <sub>3</sub>	a	b	c	g	g <sub>1</sub>	h	h <sub>1</sub>	l	l <sub>1</sub>	m	n	u	v	s	r*
																		max.
50	55	-	M50x1,5	350	125	40	52	33	115	205	135	210	290	75	20	30	M16	1,0
	47							-										
60	65	-	M60x2	370	130	45	55	37	125	220	140	220	310	80	20	30	M16	1,0
	57							-										
70	75	-	M70x2	410	150	48	62	41	135	240	160	225	340	80	25	35	M20	1,0
	67																	
80	85	-	M80x2	490	160	50	70	47	150	270	170	235	400	80	30	45	M24	1,0
	77							-										
90	95	-	M90x2	500	165	55	72	51	175	305	175	250	420	80	30	45	M24	1,0
	87							-										
100	106	-	M100x2	550	165	55	72	58	175	320	175	250	440	80	36	50	M30	1,6
	97							-										
110	120	-	M110x2	570	180	65	77	62	180	335	190	270	460	95	36	50	M30	2,5
	107							-										
120	126	-	M120x2	660	200	75	90	66	220	390	210	300	530	110	42	60	M36	1,6
	117							-										
130	140	-	M130x2	660	200	80	86	72	235	420	220	315	530	110	42	60	M36	2,5
	127							-										
140	146	-	M140x2	710	220	85	95	76	260	450	230	325	580	125	42	60	M36	1,6
	137							-										
150	160	-	M150x2	760	200	85	95	82	265	465	240	335	630	125	42	60	M36	2,5
	147							-										
160	166	-	M160x3	820	240	90	100	86	270	485	250	350	670	130	48	70	M42	1,6
	155							-										
170	180	-	M170x3	830	240	90	105	92	280	510	255	350	670	130	48	70	M42	2,5
	165							-										
180	190	-	M180x3	840	240	90	108	95	290	530	260	360	680	130	48	70	M42	2,5
	175							-										

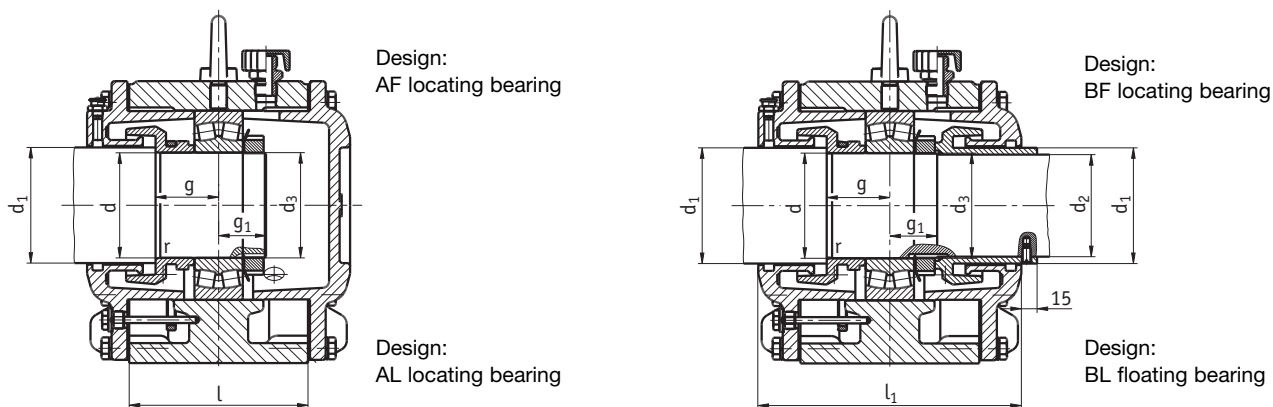

Axial displacement in case of floating bearing arrangement

SNOE 310 ... 332	10 mm
SNOE 334 ... 336	15 mm

We will also be glad to supply you with SNOE plummer block housings as complete unit with shaft. Provided that you notify us of the dimensions of your mating structure. Example, see page 58.

code number		bearing	mounting parts		oil level [mm]	oil quantity for initial fill approx. l	housing weight approx. kg
locating bearing	floating bearing		lock nut	lock washer			
SNOE 310 AF	SNOE 310 AL	22310	KM 10	MB 10	50-65	0,9	30
SNOE 310 BF	SNOE 310 BL						
SNOE 312 AF	SNOE 312 AL	22312	KM 12	MB 12	50-65	1,0	35
SNOE 312 BF	SNOE 312 BL						
SNOE 314 AF	SNOE 314 AL	22314	KM 14	MB 14	50-65	1,4	45
SNOE 314 BF	SNOE 314 BL						
SNOE 316 AF	SNOE 316 AL	22316	KM 16	MB 16	55-70	1,6	60
SNOE 316 BF	SNOE 316 BL						
SNOE 318 AF	SNOE 318 AL	22318	KM 18	MB 18	65-85	2,3	73
SNOE 318 BF	SNOE 318 BL						
SNOE 320 AF	SNOE 320 AL	22320	KM 20	MB 20	55-75	2,4	81
SNOE 320 BF	SNOE 320 BL						
SNOE 322 AF	SNOE 322 AL	22322	KM 22	MB 22	45-65	2,4	100
SNOE 322 BF	SNOE 322 BL						
SNOE 324 AF	SNOE 324 AL	22324	KM 24	MB 24	65-90	3,7	130
SNOE 324 BF	SNOE 324 BL						
SNOE 326 AF	SNOE 326 AL	22326	KM 26	MB 26	75-105	4,2	142
SNOE 326 BF	SNOE 326 BL						
SNOE 328 AF	SNOE 328 AL	22328	KM 28	MB 28	80-110	6,7	170
SNOE 328 BF	SNOE 328 BL						
SNOE 330 AF	SNOE 330 AL	22330	KM 30	MB 30	75-110	6,2	200
SNOE 330 BF	SNOE 330 BL						
SNOE 332 AF	SNOE 332 AL	22332	KM 32	MB 32	80-105	7,0	240
SNOE 332 BF	SNOE 332 BL						
SNOE 334 AF	SNOE 334 AL	22334	KM 34	MB 34	80-105	7,2	270
SNOE 334 BF	SNOE 334 BL						
SNOE 336 AF	SNOE 336 AL	22336	KM 36	MB 36	80-105	7,4	330
SNOE 336 BF	SNOE 336 BL						

# Mine Car Bearing Housings TVN 200

for bearings with cylindrical bore

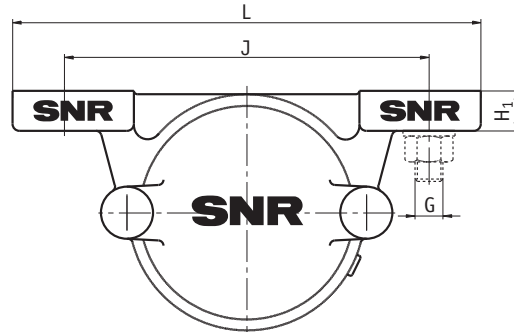
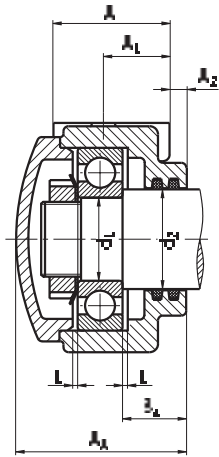

Design A  
Housing for shaft ends

shaft		dimensions [mm]										
d <sub>1</sub>	d <sub>2</sub>	bearing housing code number	A <sub>A</sub>	A <sub>B</sub>	H	H <sub>1</sub>	J	L	A	A <sub>1</sub>	A <sub>2</sub>	B <sub>a</sub>
20	25	TVN 204 A	61		35	14	110	150	45	25	6	23,5
	25	TVN 204 B		68	35	14	110	150	45	25	6	23,5
25	30	TVN 205 A	63		40	16	130	170	45	25	7	24,0
	30	TVN 205 B		71	40	16	130	170	45	25	7	24,0
30	35	TVN 206 A	71		50	16	150	190	52	30	7	27,0
	35	TVN 206 B		76	50	16	150	190	52	30	7	27,0
35	45	TVN 207 A	77		50	18	150	190	52	30	8	28,5
	45	TVN 207 B		78	50	18	150	190	52	30	8	28,5
40	50	TVN 208 A	86		60	18	170	210	60	35	8	33,0
	50	TVN 208 B		92	60	18	170	210	60	35	8	33,0
45	55	TVN 209 A	87		60	20	170	210	60	35	8	32,0
	55	TVN 209 B		92	60	20	170	210	60	35	8	32,0
50	60	TVN 210 A	90		60	20	170	210	60	35	8	34,0
	60	TVN 210 B		94	60	20	170	210	60	35	8	34,0
55	65	TVN 211 A	95		70	23	210	270	70	40	8	34,5
	65	TVN 211 B		100	70	23	210	270	70	40	8	34,5
60	70	TVN 212 A	102		70	23	210	270	70	40	10	39,0
	70	TVN 212 B		105	70	23	210	270	70	40	10	39,0
65	75	TVN 213 A	110		80	25	230	290	80	45	10	40,5
	75	TVN 213 B		115	80	25	230	290	80	45	10	40,5
70	80	TVN 214 A	111		80	25	230	290	80	45	10	40,5
	80	TVN 214 B		115	80	25	230	290	80	45	10	40,5
75	85	TVN 215 A	115		80	25	230	290	80	45	10	41,5
	85	TVN 215 B		117	80	25	230	290	80	45	10	41,5



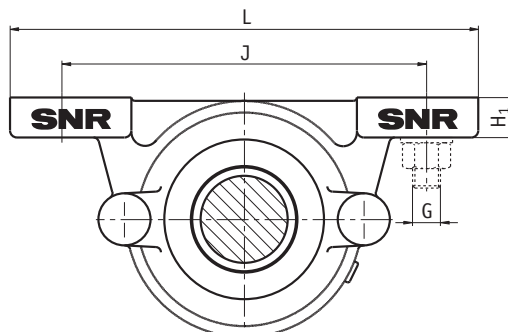
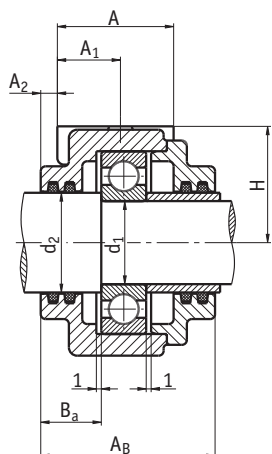

Design B  
Housing for through shafts

fastening G	housing weight approx. kg	suitable bearings		felt strips*	lock nut	lock washer
		self-aligning ball bearing	deep groove ball bearing			
M12	1,2	1204	6204	FS 6 x 5 x 118	KM 4	MB 4
M12	1,2	1204	6204	FS 6 x 5 x 118		
M12	1,4	1205	6205	FS 6 x 5 x 132	KM 5	MB 5
M12	1,4	1205	6205	FS 6 x 5 x 132		
M12	2,2	1206	6206	FS 6 x 5 x 150	KM 6	MB 6
M12	2,2	1206	6206	FS 6 x 5 x 150		
M12	2,6	1207	6207	FS 6 x 5 x 180	KM 7	MB 7
M12	2,6	1207	6207	FS 6 x 5 x 180		
M12	3,7	1208	6208	FS 8 x 6,5 x 210	KM 8	MB 8
M12	3,7	1208	6208	FS 8 x 6,5 x 210		
M12	4,0	1209	6209	FS 8 x 6,5 x 225	KM 9	MB 9
M12	4,0	1209	6209	FS 8 x 6,5 x 225		
M12	4,2	1210	6210	FS 8 x 6,5 x 240	KM 10	MB 10
M12	4,2	1210	6210	FS 8 x 6,5 x 240		
M16	6,2	1211	6211	FS 8 x 6,5 x 260	KM 11	MB 11
M16	6,2	1211	6211	FS 8 x 6,5 x 260		
M16	6,7	1212	6212	FS 9 x 7,5 x 280	KM 12	MB 12
M16	6,7	1212	6212	FS 9 x 7,5 x 280		
M16	9,1	1213	6213	FS 9 x 7,5 x 300	KM 13	MB 13
M16	9,1	1213	6213	FS 9 x 7,5 x 300		
M16	9,4	1214	6214	FS 9 x 7,5 x 315	KM 14	MB 14
M16	9,4	1214	6214	FS 9 x 7,5 x 315		
M16	9,9	1215	6215	FS 9 x 7,5 x 330	KM 15	MB 15
M16	9,9	1215	6215	FS 9 x 7,5 x 330		

\* = 2x for design A  
4x for design B

TVN also available as hardening car  
bearing housings for high temperature applications (s. p. 37).

# Mine Car Bearing Housings TVN 300

for bearings with cylindrical bore

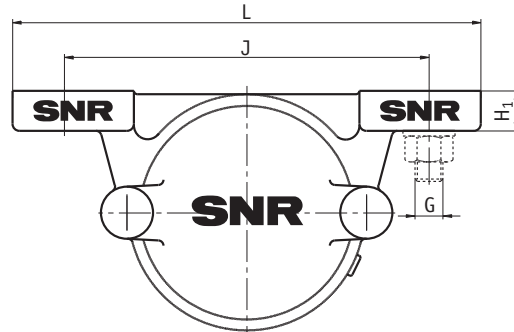
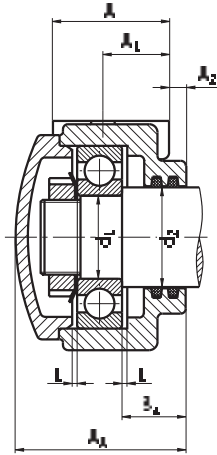

Design A  
Housing for shaft ends

shaft		dimensions [mm]										
d <sub>1</sub>	d <sub>2</sub>	bearing housing code number	A <sub>A</sub>	A <sub>B</sub>	H	H <sub>1</sub>	J	L	A	A <sub>1</sub>	A <sub>2</sub>	B <sub>a</sub>
20	25	TVN 304 A	63		40	16	130	170	45	25	7	24,0
	25	TVN 304 B		71	40	16	130	170	45	25	7	24,0
25	30	TVN 305 A	71		50	16	150	190	52	30	7	26,5
	30	TVN 305 B		76	50	16	150	190	52	30	7	26,5
30	40	TVN 306 A	77		50	18	150	190	52	30	8	27,5
	40	TVN 306 B		78	50	18	150	190	52	30	8	27,5
35	45	TVN 307 A	86		60	18	170	210	60	35	8	31,5
	45	TVN 307 B		92	60	18	170	210	60	35	8	31,5
40	50	TVN 308 A	90		60	20	170	210	60	35	8	32,5
	50	TVN 308 B		94	60	20	170	210	60	35	8	32,5
45	55	TVN 309 A	95		70	23	210	270	70	40	8	32,5
	55	TVN 309 B		100	70	23	210	270	70	40	8	32,5
50	60	TVN 310 A	102		70	23	210	270	70	40	10	36,5
	60	TVN 310 B		105	70	23	210	270	70	40	10	36,5
55	65	TVN 311 A	110		80	25	230	290	80	45	10	37,5
	65	TVN 311 B		115	80	25	230	290	80	45	10	37,5
60	70	TVN 312 A	115		80	25	230	290	80	45	10	38,5
	70	TVN 312 B		117	80	25	230	290	80	45	10	38,5
65	75	TVN 313 A	122		95	28	260	330	90	50	12	42,5
	75	TVN 313 B		127	95	28	260	330	90	50	12	42,5
70	80	TVN 314 A	126		95	28	260	330	90	50	12	43,5
	80	TVN 314 B		129	95	28	260	330	90	50	12	43,5
75	85	TVN 315 A	136		100	30	290	360	100	55	13	47,5
	85	TVN 315 B		139	100	30	290	360	100	55	13	47,5

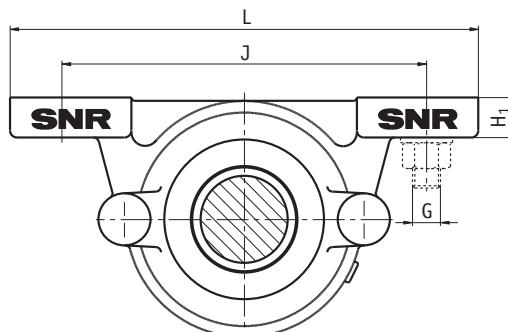
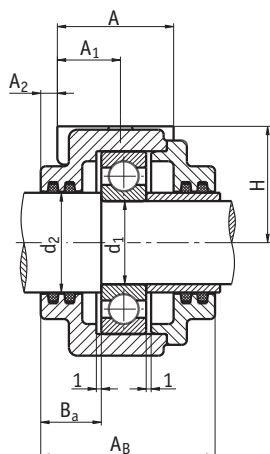

Design B  
Housing for through shafts

fastening G	housing weight approx. kg	suitable bearings		felt strips*	lock nut	lock washer
		self-aligning ball bearing	deep groove ball bearing			
M12	1,6	1304	6304	FS 6 x 5 x 118	KM 4	MB 4
M12	1,6	1304	6304	FS 6 x 5 x 118		
M12	2,3	1305	6305	FS 6 x 5 x 132	KM 5	MB 5
M12	2,3	1305	6305	FS 6 x 5 x 132		
M12	2,6	1306	6306	FS 6 x 5 x 165	KM 6	MB 6
M12	2,6	1306	6306	FS 6 x 5 x 165		
M12	3,9	1307	6307	FS 6 x 5 x 180	KM 7	MB 7
M12	3,9	1307	6307	FS 6 x 5 x 180		
M12	4,2	1308	6308	FS 8 x 6,5 x 210	KM 8	MB 8
M12	4,2	1308	6308	FS 8 x 6,5 x 210		
M16	6,3	1309	6309	FS 8 x 6,5 x 225	KM 9	MB 9
M16	6,3	1309	6309	FS 8 x 6,5 x 225		
M16	6,9	1310	6310	FS 8 x 6,5 x 240	KM 10	MB 10
M16	6,9	1310	6310	FS 8 x 6,5 x 240		
M16	9,3	1311	6311	FS 8 x 6,5 x 260	KM 11	MB 11
M16	9,3	1311	6311	FS 8 x 6,5 x 260		
M16	10,0	1312	6312	FS 9 x 7,5 x 280	KM 12	MB 12
M16	10,0	1312	6312	FS 9 x 7,5 x 280		
M20	13,5	1313	6313	FS 9 x 7,5 x 300	KM 13	MB 13
M20	13,5	1313	6313	FS 9 x 7,5 x 300		
M20	14,0	1314	6314	FS 9 x 7,5 x 315	KM 14	MB 14
M20	14,0	1314	6314	FS 9 x 7,5 x 315		
M20	18,5	1315	6315	FS 9 x 7,5 x 330	KM 15	MB 15
M20	18,5	1315	6315	FS 9 x 7,5 x 330		

\* = 2x for design A  
4x for design B

TVN also available as hardening car  
bearing housings for high temperature applications (s. p. 37).

# Hardening Car Bearing Housings TVN 6200/6300 for bearing with cylindrical bore, for high temperature applications

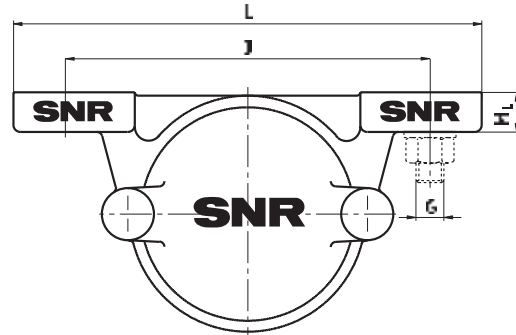
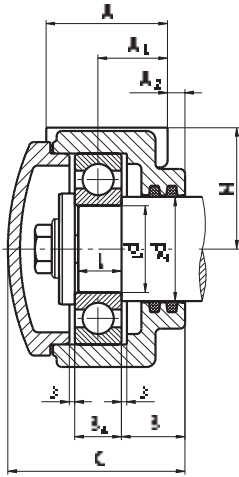

shaft		bearing housing		dimensions [mm]									
d <sub>1</sub>	d <sub>2</sub>	code number	C	H	H <sub>1</sub>	J	L	A	A <sub>1</sub>	A <sub>2</sub>	B	B <sub>a</sub>	I
35	40	TVN 6207 A	76	50	18	210	255	57	38,5	10	17	30	15
40	45	TVN 6208 A	81	55	17	210	255	56	39	11	18	30	16
45	55	TVN 6309 A	96	70	18	210	256	55	44	10	25	32,5	23
50	60	TVN 6310 A	102	70	23	210	270	70	50	10	27	36,5	25
55	65	TVN 6211 A	95	70	23	210	270	70	45	8	21	34,5	19
65	75	TVN 6213 A	108,5	80	25	230	290	80	52	10	23	40,5	21

fastening G	weight approx. kg	suitable bearing deep groove ball bearing	Hostaflon TF 1645 filling quantity in g	hot steam packaging 2 x Arolan II
M16	2,6	6207 F605	50	6 x 6 x 145
M16	3,7	6208 F605	60	6 x 6 x 160
M16	6,3	6309 F605	95	6 x 6 x 175
M16	6,9	6310 F605	140	6 x 6 x 205
M16	6,2	6211 F605	110	6 x 6 x 220
M16	9,1	6213 F605	150	8 x 8 x 260

The listed bearing housings with deep groove ball bearing from series **62.. F605** and **63..F605** may only be used in the sand-lime brick hardening shop area.

For all other high temperature applications, e.g. clinker hardening plants, deep groove ball bearings from series **62..F600** and **63.. F600** must be used. The lubricant must also be changed: **Klüber Wolfrasyne U1af**.

Please contact an SNR engineer.

# Plummer Block Housings TN200/300

for self-aligning ball bearing with widened inner ring

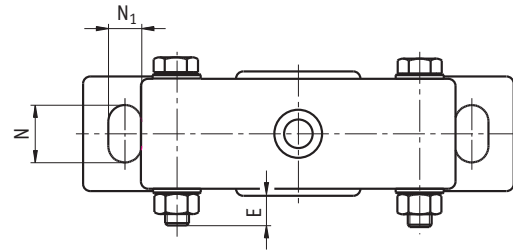
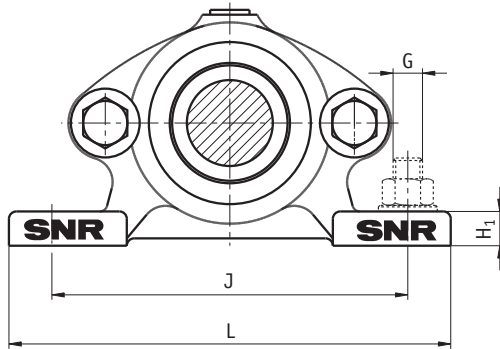

		dimensions [mm]								
shaft	bearing housing	H	J	N <sub>1</sub>	N	I	L	A <sub>1</sub>	H <sub>1</sub>	H <sub>2</sub>
d <sub>1</sub>	code number									
20	TN 204	40	115	14	20	40	145	42	12	74
	TN 304	40	120	14	20	44	150	42	12	77
25	TN 205	40	120	14	20	44	150	42	12	77
	TN 305	50	130	14	24	48	165	48	14	93
30	TN 206	50	130	14	24	48	165	48	14	93
	TN 306	50	145	14	24	52	180	48	14	98
35	TN 207	50	145	14	24	52	180	48	14	98
	TN 307	55	160	14	24	56	195	52	16	108
40	TN 208	55	160	14	24	56	195	52	16	108
	TN 308	60	175	14	24	58	210	56	16	120
45	TN 209	60	175	14	24	58	210	56	16	116
	TN 309	65	190	17	27	60	230	62	18	129
50	TN 210	60	175	14	24	58	210	56	16	120
	TN 310	70	205	17	27	62	245	66	18	140
55	TN 211	65	190	17	27	60	230	62	18	129
60	TN 212	70	205	17	27	62	245	66	18	140



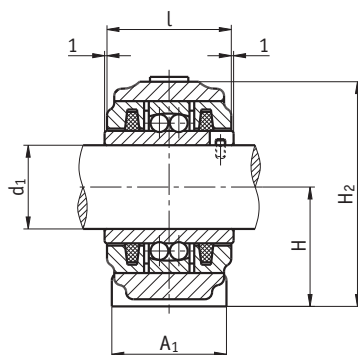

G	fastening and mounting	E	housing weight approx. kg	suitable bearing
M12		6,5	1,1	11204
M12		8,5	1,1	11304
M12		8,5	1,1	11205
M12		10,0	1,8	11305
M12		10,0	1,7	11206
M12		8,0	1,9	11306
M12		8,0	1,8	11207
M12		8,5	2,4	11307
M12		8,5	2,4	11208
M12		6,0	3,0	11308
M12		7,5	2,7	11209
M16		8,0	4,1	11309
M12		6,0	3,0	11210
M16		10,0	4,6	11310
M16		8,0	3,9	11211
M16		10,0	4,6	11212

# Double Bearing Housings ZLG 300

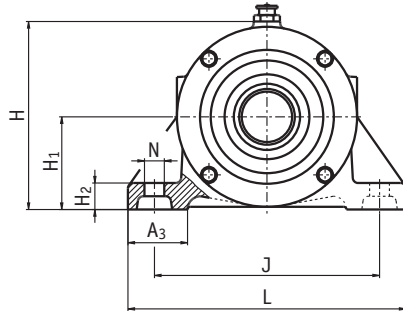

shaft		bearing housing																		
d	d <sub>1</sub>	code number	A	A <sub>1</sub>	A <sub>2</sub>	A <sub>3</sub>	H	H <sub>1</sub>	H <sub>2</sub>	J	J <sub>1</sub>	L	N	W	W <sub>1</sub>	W <sub>2</sub>	B	d <sub>3</sub>		
30	40	ZLG 306	235	30	20	40	100	50	16	130	150	170	15	173,0	140,0	57,0	53,0	-		
														174,5	141,5			35		
														174,5	140,5			-		
35	45	ZLG 307	275	30	20	40	117	60	16	150	175	190	15	197,0	160,0	66,5	60,0	-		
														198,5	161,5			69,0	62,5	40
														198,5	160,5			66,5	60,0	-
40	50	ZLG 308	330	36	26	40	121	60	18	150	225	190	15	257,0	214,0	69,5	65,0	-		
														258,5	215,5			50		
														258,5	214,5			-		
45	55	ZLG 309	370	36	26	45	139	70	20	170	250	210	15	280,5	235,5	78,5	72,5	-		
														282,5	237,5			55		
														282,5	236,5			-		
50	60	ZLG 310	405	40	30	45	142	70	20	170	275	210	15	314,5	265,5	81,0	77,5	-		
														316,5	267,5			60		
														316,5	266,5			-		
55	65	ZLG 311	433	40	30	60	158	80	23	210	300	270	20	336,5	287,5	84,0	79,0	-		
														338,5	289,5			65		
														338,5	288,0			-		
60	70	ZLG 312	479	40	30	60	162	80	23	210	340	270	20	384,0	333,0	84,0	81,5	-		
														385,5	334,5			87,5	85,0	70
														385,5	333,0			84,0	81,5	-
65	75	ZLG 313	503	45	35	60	187	95	25	230	360	290	20	402,0	348,0	88,0	83,5	-		
														404,5	350,5			91,5	87,0	75
														404,5	349,0			88,0	83,5	-

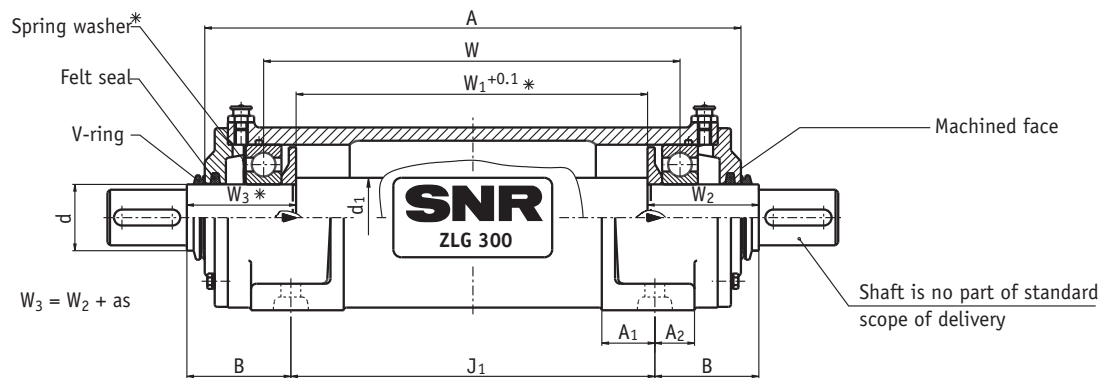

\* The spring washer may not be mounted for alternating axial loads. Dimension W1 is then increased by dimension "as", W3 is then equal to W2.

## Design AA

If you notify us the dimensions of the mating structure for your design, we will be glad to supply you with double or triple bearing housings fully mounted, pre-lubricated and with a corresponding shaft. That means that you have the advantage of getting the complete unit from one supplier only.

p	as	mounting parts		felt ring	V-ring	spring washer	unit designation	housing weight approx. kg
		bearing 1	bearing 2					
-	1,5	6306 C3	6306 C3	FI 7	V-30S	ASG 6306	ZLG 306 AA	8
31	-	NU 306 EG15 C3		FI 8	V-35S	-	ZLG 306 AB	
-	-	NJ 306 EG15 C3		FI 7	V-30S	-	ZLG 306 AC	
-	1,5	6307 C3	6307 C3	FI 8	V-35S	ASG 6307	ZLG 307 AA	10
40	-	NU 307 EG15 C3		FI 9	V-40S	-	ZLG 307 AB	
-	-	NJ 307 EG15 C3		FI 8	V-35S	-	ZLG 307 AC	
-	1,5	6308 C3	6308 C3	FI 9	V-40S	ASG 6308	ZLG 308 AA	12
36,5	-	NU 308 EG15 C3		FI 11	V-50S	-	ZLG 308 AB	
-	-	NJ 308 EG15 C3		FI 9	V-40S	-	ZLG 308 AC	
-	2,0	6309 C3	6309 C3	FI 10	V-45S	ASG 6309	ZLG 309 AA	16
43,5	-	NU 309 EG15 C3		FI 12	V-55S	-	ZLG 309 AB	
-	-	NJ 309 EG15 C3		FI 10	V-45S	-	ZLG 309 AC	
-	2,0	6310 C3	6310 C3	FI 11	V-50S	ASG 6310	ZLG 310 AA	19
43	-	NU 310 EG15 C3		FI 13	V-60S	-	ZLG 310 AB	
-	-	NJ 310 EG15 C3		FI 11	V-50S	-	ZLG 310 AC	
-	2,0	6311 C3	6311 C3	FI 12	V-55S	ASG 6311	ZLG 311 AA	25
45	-	NU 311 EG15 C3		FI 15	V-65S	-	ZLG 311 AB	
-	-	NJ 311 EG15 C3		FI 12	V-55S	-	ZLG 311 AC	
-	1,5	6312 C3	6312 C3	FI 13	V-60S	ASG 6312	ZLG 312 AA	30
46,5	-	NU 312 EG15 C3		FI 16	V-70S	-	ZLG 312 AB	
-	-	NJ 312 EG15 C3		FI 13	V-60S	-	ZLG 312 AC	
-	2,5	6313 C3	6313 C3	FI 15	V-65S	ASG 6313	ZLG 313 AA	33
48	-	NU 313 EG15 C3		FI 17	V-75S	-	ZLG 313 AB	
-	-	NJ 313 EG15 C3		FI 15	V-65S	-	ZLG 313 AC	

# Double Bearing Housings ZLG 300

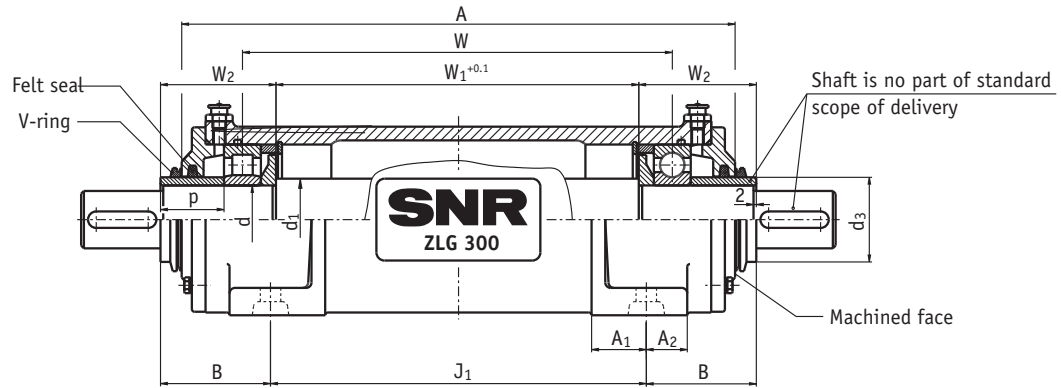

## Design AB

shaft		bearing housing																	
d	d <sub>1</sub>	code number	A	A <sub>1</sub>	A <sub>2</sub>	A <sub>3</sub>	H	H <sub>1</sub>	H <sub>2</sub>	J	J <sub>1</sub>	L	N	W	W <sub>1</sub>	W <sub>2</sub>	B	d <sub>3</sub>	
70	80	ZLG 314	534	45	35	60	190	95	25	230	380	290	20	421,0	364,0	99,0	92,5	-	
														423,5	366,5			80	
														423,5	365,0			-	
75	90	ZLG 315	559	45	35	70	200	100	28	260	400	330	20	450,0	389,0	99,0	95,0	-	
														452,5	391,5			90	
														452,5	390,0			-	
80	95	ZLG 316	585	50	40	70	220	112	30	260	420	330	20	468,0	405,0	104,0	98,0	-	
														470,5	407,5			95	
														470,5	406,0			-	
85	100	ZLG 317	593	50	40	70	225	112	30	290	440	350	20	478,0	415,0	103,0	92,0	-	
														480,5	417,5			100	
														480,5	416,0			-	
90	105	ZLG 318	605	55	45	70	230	112	30	290	460	350	20	483,5	418,5	107,0	88,0	-	
														486,5	421,5			110	
														486,5	420,0			110	
95	110	ZLG 319	633	60	50	90	248	125	35	320	480	400	24	508,5	440,5	110,5	92,0	-	
														511,5	443,5			110	
														511,5	442,0			110	
100	115	ZLG 320	673	60	50	80	264	130	40	320	500	400	24	533,0	463,0	118,5	102,0	-	
														536,5	466,5			120	
														536,5	465,0			120	
110	130	ZLG 322	678	70	60	100	296	150	40	380	520	450	26	577,0	504,0	102,5	96,5	-	
														580,5	507,5			130	
														580,5	506,0			-	
120	140	ZLG 324	705	78	60	115	320	160	40	410	540	500	35	599,5	521,5	107,5	100,0	-	
														602,5	524,5			140	
														602,5	523,0			-	

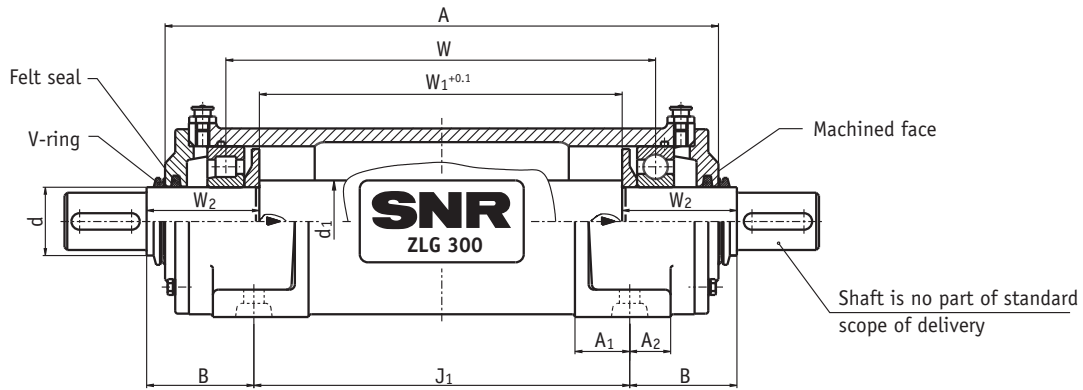

## Design AC

If you notify us the dimensions of the mating structure for your design, we will be glad to supply you with double or triple bearing housings fully mounted, pre-lubricated and with a corresponding shaft. That means that you have the advantage of getting the complete unit from one supplier only.

p	as	mounting parts		felt ring	V-ring	spring washer	unit designation	housing weight approx. kg
		bearing 1	bearing 2					
-	2,5	6314 C3	6314 C3	FI 16	V-70S	ASG 6314	ZLG 314 AA	37
53	-	NU 314 EG15 C3		FI 18	V-80S	-	ZLG 314 AB	
-	-	NJ 314 EG15 C3		FI 16	V-70S	-	ZLG 314 AC	
-	2,5	6315 C3	6315 C3	FI 17	V-75S	ASG 6315	ZLG 315 AA	47
50	-	NU 315 EG15 C3		FI 20	V-90S	-	ZLG 315 AB	
-	-	NJ 315 EG15 C3		FI 17	V-75S	-	ZLG 315 AC	
-	2,5	6316 C3	6316 C3	FI 18	V-80S	ASG 6316	ZLG 316 AA	56
53	-	NU 316 EG15 C3		FI 21	V-95S	-	ZLG 316 AB	
-	-	NJ 316 EG15 C3		FI 18	V-80S	-	ZLG 316 AC	
-	2,5	6317 C3	6317 C3	FI 19	V-85S	ASG 6317	ZLG 317 AA	64
51	-	NU 317 EG15 C3		FI 22	V-100S	-	ZLG 317 AB	
-	-	NJ 317 EG15 C3		FI 19	V-85S	-	ZLG 317 AC	
-	3,0	6318 C3	6318 C3	FI 20	V-90S	ASG 6318	ZLG 318 AA	71
55	-	NU 318 EG15 C3		FI 24	V-110S	-	ZLG 318 AB	
-	-	NJ 318 EG15 C3		FI 20	V-90S	-	ZLG 318 AC	
-	3,0	6319 C3	6319 C3	FI 21	V-95S	ASG 6319	ZLG 319 AA	82
56	-	NU 319 EG15 C3		FI 24	V-110S	-	ZLG 319 AB	
-	-	NJ 319 EG15 C3		FI 21	V-95S	-	ZLG 319 AC	
-	3,5	6320 C3	6320 C3	FI 22	V-100S	ASG 6320	ZLG 320 AA	93
62	-	NU 320 EG15 C3		FI 27	V-120S	-	ZLG 320 AB	
-	-	NJ 320 EG15 C3		FI 22	V-100S	-	ZLG 320 AC	
-	3,5	6322 C3	6322 C3	FI 24	V-110S	ASG 6322	ZLG 322 AA	110
41	-	NU 322 EG15 C3		FI 29	V-130S	-	ZLG 322 AB	
-	-	NJ 322 EG15 C3		FI 24	V-110S	-	ZLG 322 AC	
-	3,0	6324 C3	6324 C3	FI 27	V-120S	ASG 6324	ZLG 324 AA	150
41	-	NU 324 EG15 C3		FI 32	V-140S	-	ZLG 324 AB	
-	-	NJ 324 EG15 C3		FI 27	V-120S	-	ZLG 324 AC	

# Triple Bearing Housings DLG 300

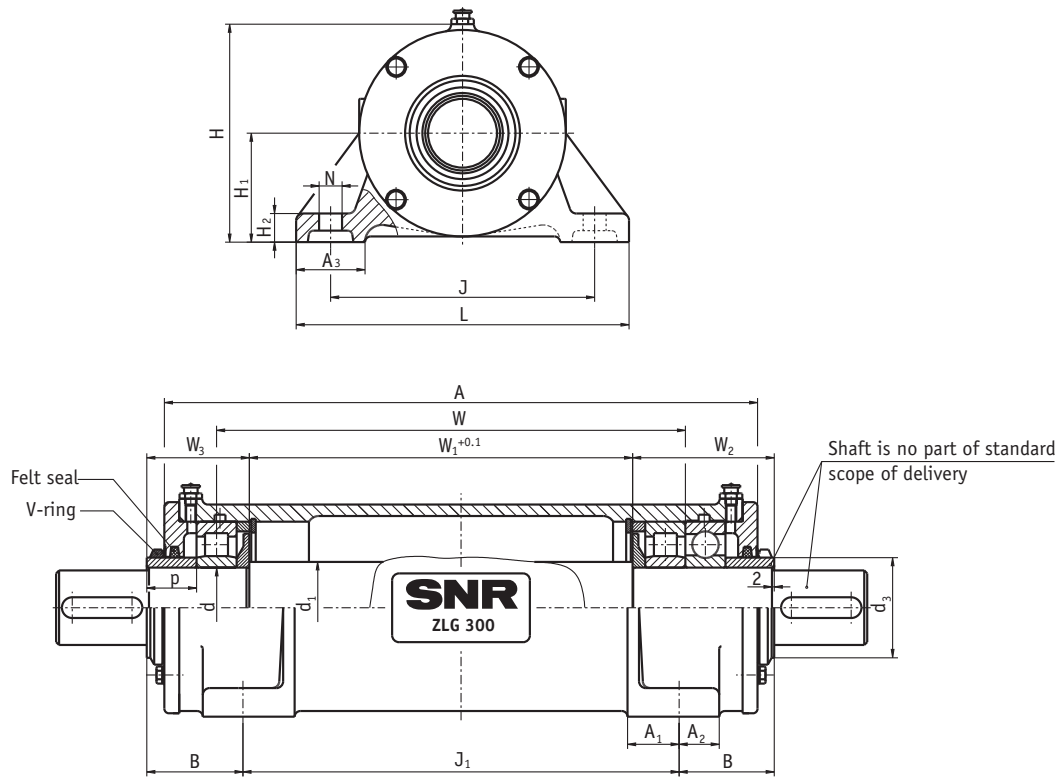

Design AD

		dimensions [mm]																				
shaft	bearing housing	d <sub>1</sub>	code number	A	A <sub>1</sub>	A <sub>2</sub>	A <sub>3</sub>	H	H <sub>1</sub>	H <sub>2</sub>	J	J <sub>1</sub>	L	N	W	W <sub>1</sub>	W <sub>2</sub>	W <sub>3</sub>	B	d <sub>3</sub>	p	as
70	80	DLG 314	517	45	35	60	190	95	25	230	380	290	20	408,5	334,0	124,0	89,0	83,5	80	43,0	-	-
														408,5	334,0	89,0	-	-				
														406,0	331,5	91,5	2,5	-				
75	90	DLG 315	553	45	35	70	200	100	28	260	400	330	20	438,5	359,0	130,5	93,5	91,5	90	44,5	-	-
														438,5	359,0	93,5	-	-				
														436,0	356,5	96,0	2,5	-				
80	95	DLG 316	577	50	40	70	220	112	30	260	420	330	20	460,0	377,5	134,5	95,5	94,0	95	44,5	-	-
														460,0	377,5	95,5	-	-				
														457,5	375,0	98,0	2,5	-				
85	100	DLG 317	593	50	40	70	225	112	30	290	440	350	20	469,0	385,5	139,5	98,5	92,0	100	46,5	-	-
														469,0	385,5	98,5	-	-				
														466,5	383,0	101,0	2,5	-				
90	105	DLG 318	599	55	45	70	230	112	30	290	460	350	20	474,0	387,5	144,5	101,5	87,0	110	47,5	-	-
														474,0	387,5	101,5	-	-				
														471,0	384,5	104,5	3,0	-				
95	110	DLG 319	626	60	50	90	248	125	35	320	480	400	24	498,0	407,5	149,0	104,0	90,5	110	47,5	-	-
														498,0	407,5	104,0	-	-				
														495,0	404,5	107,0	3,0	-				
100	115	DLG 320	657	60	50	80	264	130	40	320	500	400	24	525,5	432,0	153,0	106,0	95,5	120	47,5	-	-
														525,5	432,0	106,0	-	-				
														522,0	428,5	109,5	3,5	-				
110	130	DLG 322	678	70	60	100	296	150	40	380	520	450	26	555,5	457,5	152,5	102,5	96,5	130	41,0	-	-
														555,5	457,5	102,5	-	-				
														552,0	454,0	106,0	3,5	-				
120	140	DLG 324	705	78	60	115	320	160	40	410	540	500	35	575,0	469,5	162,5	107,5	100,0	140	41,0	-	-
														575,0	469,5	107,5	-	-				
														572,0	466,5	110,5	3,0	-				



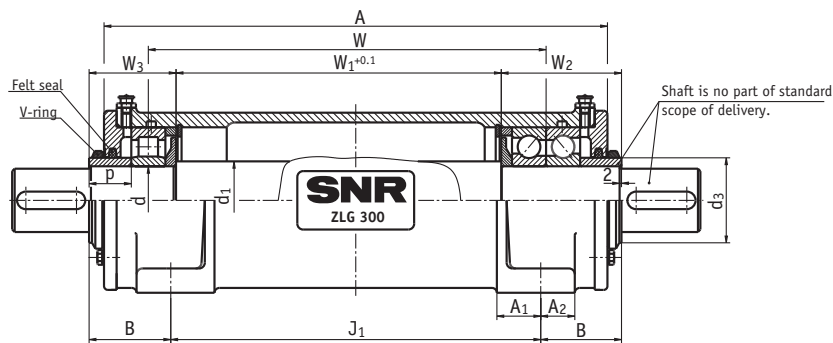

Design AE

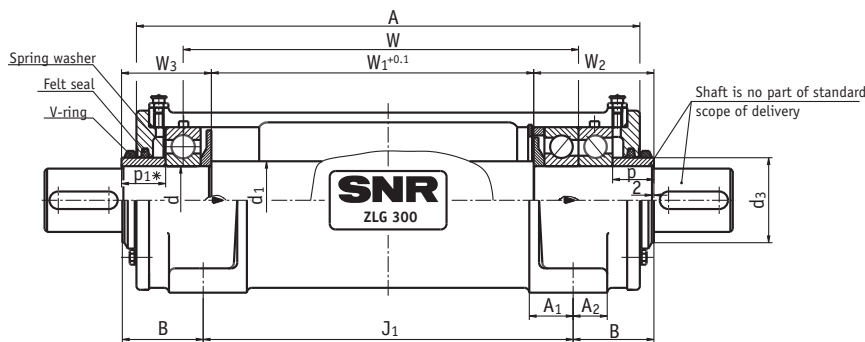

Design AF

\*  $p_1 = p + as$

If you notify us the dimensions of the mating structure for your design, we will be glad to supply you with double or triple bearing housings fully mounted, pre-lubricated and with a corresponding shaft. That means that you have the advantage of getting the complete unit from one supplier only.

mounting parts						unit designation	housing weight approx. kg
bearing 1	bearing 2	felt ring	V-ring	spring washer			
NU 314 EG15 C3	NU 314 EG15 C3 + 6314 C3	FI 18	V-80S	-	DLG 314 AD	37	
NU 314 EG15 C3	2 x 7314 BG			-	DLG 314 AE		
6314 C3	2 x 7314 BG			ASG 6314	DLG 314 AF		
NU 315 EG15 C3	NU 315 EG15 C3 + 6315 C3	FI 20	V-90S	-	DLG 315 AD	47	
NU 315 EG15 C3	2 x 7315 BG			-	DLG 315 AE		
6315 C3	2 x 7315 BG			ASG 6315	DLG 315 AF		
NU 316 EG15 C3	NU 316 EG15 C3 + 6316 C3	FI 21	V-95S	-	DLG 316 AD	56	
NU 316 EG15 C3	2 x 7316 BG			-	DLG 316 AE		
6316 C3	2 x 7316 BG			ASG 6316	DLG 316 AF		
NU 317 EG15 C3	NU 317 EG15 C3 + 6317 C3	FI 22	V-100S	-	DLG 317 AD	64	
NU 317 EG15 C3	2 x 7317 BG			-	DLG 317 AE		
6317 C3	2 x 7317 BG			ASG 6317	DLG 317 AF		
NU 318 EG15 C3	NU 318 EG15 C3 + 6318 C3	FI 24	V-110S	-	DLG 318 AD	71	
NU 318 EG15 C3	2 x 7318 BG			-	DLG 318 AE		
6318 C3	2 x 7318 BG			ASG 6318	DLG 318 AF		
NU 319 EG15 C3	NU 319 EG15 C3 + 6319 C3	FI 24	V-110S	-	DLG 319 AD	82	
NU 319 EG15 C3	2 x 7319 BG			-	DLG 319 AE		
6319 C3	2 x 7319 BG			ASG 6319	DLG 319 AF		
NU 320 EG15 C3	NU 320 EG15 C3 + 6320 C3	FI 27	V-120S	-	DLG 320 AD	93	
NU 320 EG15 C3	2 x 7320 BG			-	DLG 320 AE		
6320 C3	2 x 7320 BG			ASG 6320	DLG 320 AF		
NU 322 EG15 C3	NU 322 EG15 C3 + 6322 C3	FI 29	V-130S	-	DLG 322 AD	110	
NU 322 EG15 C3	2 x 7322 BG			-	DLG 322 AE		
6322 C3	2 x 7322 BG			ASG 6322	DLG 322 AF		
NU 324 EG15 C3	NU 324 EG15 C3 + 6324 C3	FI 32	V-140S	-	DLG 324 AD	150	
NU 324 EG15 C3	2 x 7324 BG			-	DLG 324 AE		
6324 C3	2 x 7324 BG			ASG 6324	DLG 324 AF		

# Double Bearing Housings ZLOE 200/300

for cylindrical roller bearings and deep groove ball bearings, specified for oil lubrication

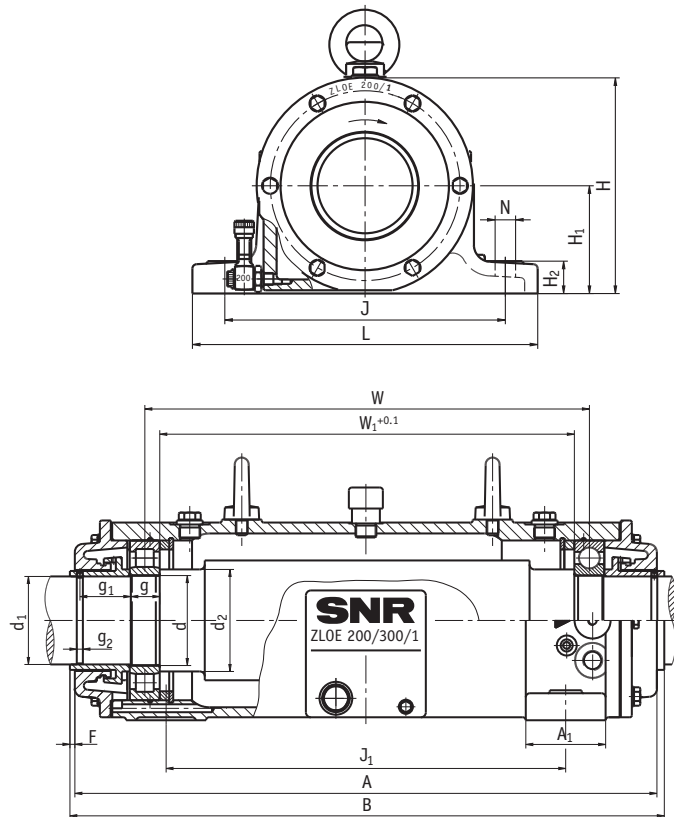

Design B

shaft		dimensions [mm]															
d	d <sub>1</sub>	d <sub>2</sub>	bearing housing code number	A	A <sub>1</sub>	B	F	H	H <sub>1</sub>	H <sub>2</sub>	J	J <sub>1</sub>	L	N	W	W <sub>1</sub>	
90	88	102	ZLOE 218/1	582,5	80	595,0	5	200	100	30	260	400	320	19	445,0	415,0	
95	93	110	ZLOE 219/1	645,0	80	657,5	5	227	112	30	290	440	350	19	493,5	461,5	
100	98	115	ZLOE 220/1	645,0	80	657,5	5	227	112	30	290	440	350	19	491,5	457,5	
110	108	122	ZLOE 222/1	688,5	90	715,5	12	254	125	36	320	480	400	24	536,5	498,5	
75	72	90	ZLOE 315/1	582,5	80	595,0	5	200	100	30	260	400	320	19	445,0	408,0	
85	82	100	ZLOE 317/1	645,0	80	657,5	5	227	112	30	290	440	350	19	491,5	450,5	
95	92	110	ZLOE 319/1	688,5	90	715,5	12	254	125	36	320	480	400	24	536,5	491,5	

This bearing housing can be equipped with a combination of three bearings. Please contact SNR for more informations.

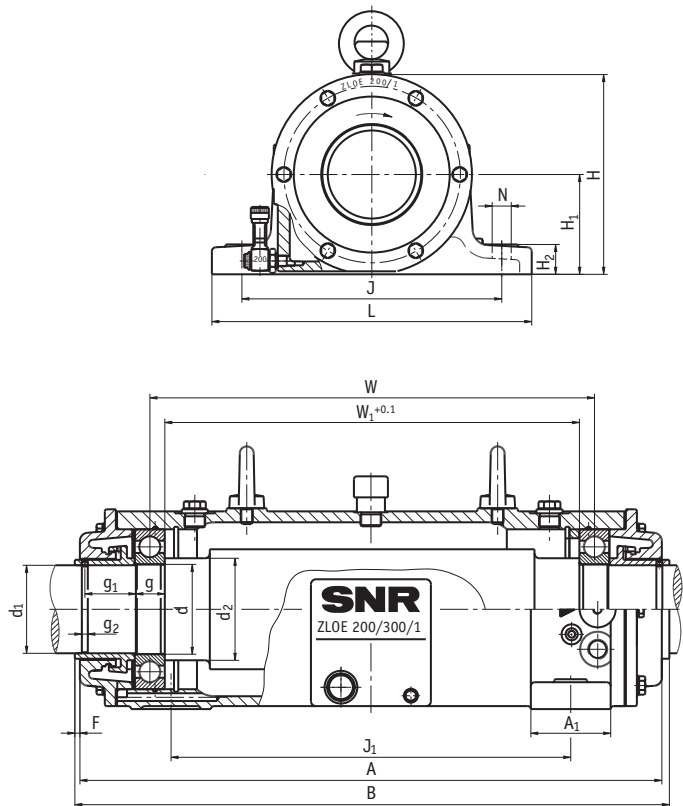

We will also be glad to supply you with ZLOE double bearing housings as complete unit with shaft. Provided that you notify us of the dimensions of your mating structure.

## Design A

g	g <sub>1</sub>	g <sub>2</sub>	mounting parts		oil level in operation [mm]	oil quantity approx. l	weight approx. kg	unit designation
			bearing 1	bearing 2				
28	52,0	6	6218 C3	6218 C3	32 - 36	0,8	75	ZLOE 218/1 A
			NU 218 C3	6218 C3				ZLOE 218/1 B
30	60,0	6	6219 C3	6219 C3	39 - 44	1,3	80	ZLOE 219/1 A
			NU 219 C3	6219 C3				ZLOE 219/1 B
32	58,0	6	6220 C3	6220 C3	36 - 41	1,3	80	ZLOE 220/1 A
			NU 220 C3	6220 C3				ZLOE 220/1 B
36	58,0	6	6222 C3	6222 C3	40 - 45	1,7	85	ZLOE 222/1 A
			NU 222 C3	6222 C3				ZLOE 222/1 B
35	49,5	6	6315 C3	6315 C3	34,5 - 37,5	0,8	75	ZLOE 315/1 A
			NU 315 C3	6315 C3				ZLOE 315/1 B
39	54,5	6	6317 C3	6317 C3	39 - 43	1,3	80	ZLOE 317/1 A
			NU 317 C3	6317 C3				ZLOE 317/1 B
43	54,5	6	6319 C3	6319 C3	43 - 46	1,8	85	ZLOE 319/1 A
			NU 319 C3	6319 C3				ZLOE 319/1 B

# Flange Bearing Housings 722500

for bearings with adapter sleeve fastening

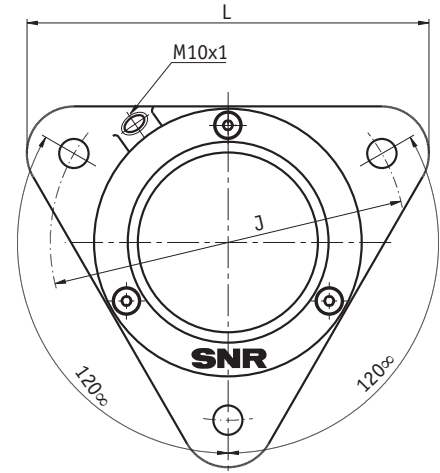
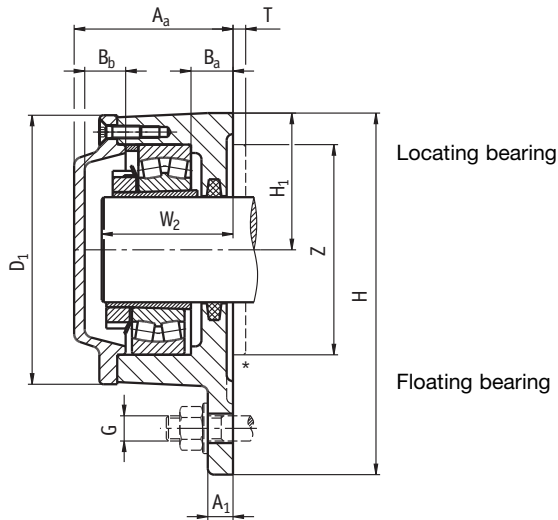

Design A  
Housing design for shaft ends

shaft d	bearing housing code number	dimensions [mm]												
		A <sub>a</sub>	A <sub>b</sub>	A <sub>1</sub>	B <sub>a</sub>	B <sub>b</sub>	D <sub>1</sub>	H	H <sub>1</sub>	J	L	W <sub>2</sub>	T*	Z*
20	722505 DA	51,5	56,5	10	15	12,5	75	100	38	96	110	44	6	65
	722505 DB	-	-	-	-	-	-	-	-	-	-	-	-	-
25	722506 DA	57,0	59,5	12	16	15	86	117	44	116	130	47	6	70
	722506 DB	-	-	-	-	-	-	-	-	-	-	-	-	-
30	722507 DA	59,5	63,5	12	16	14,5	97	130	48,5	130	145	51	6	75
	722507 DB	-	-	-	-	-	-	-	-	-	-	-	-	-
35	722508 DA	64,0	65,5	12	17	18	108	143	54	140	160	53	6	80
	722508 DB	-	-	-	-	-	-	-	-	-	-	-	-	-
40	722509 DA	64,5	69,5	12	19	16,5	113	160	60	160	180	56	6	85
	722509 DB	-	-	-	-	-	-	-	-	-	-	-	-	-
45	722510 DA	68,5	73	12	22	17,5	118	160	60	160	180	60	6	90
	722510 DB	-	-	-	-	-	-	-	-	-	-	-	-	-
50	722511 DA	75,5	81,5	12	24	19,5	128	172	65	170	192	64	6	100
	722511 DB	-	-	-	-	-	-	-	-	-	-	-	-	-
55	722512 DA	77,0	82	12	23	19	142	189	72	180	210	66	10	110
	722512 DB	-	-	-	-	-	-	-	-	-	-	-	-	-
60	722513 DA	80	86	15	22	20	152	203	78	190	225	69	10	120
	722513 DB	-	-	-	-	-	-	-	-	-	-	-	-	-

\* Housings are also available with centring on the mating surface.

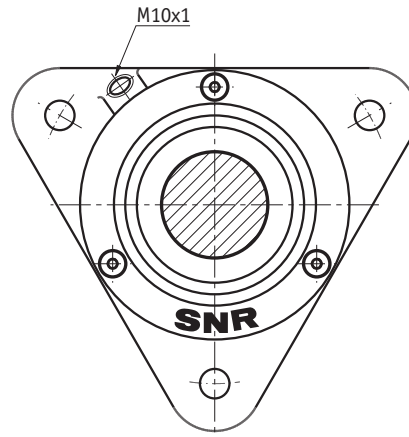
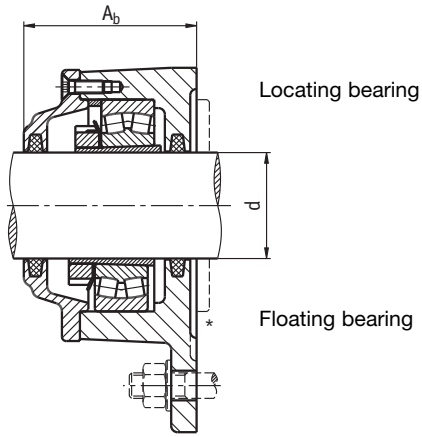

Design B  
Housing for through shafts

fastening G	weight approx. kg	suitable bearing	mounting parts			code number	cover bolts *1 DIN 7991	felt strips DIN 5419 F2	housing design
			adaptor sleeves	locating rings number	code number				
M10	1,1	1205 K C3	H 205	1	FR 52/5	M 5 x 16	FS 5 x 4 x 95		
		2205 K C3	H 305	1	FR 52/2				
M10	1,5	1206 K C3	H 206	1	FR 62/6	M 5 x 16	FS 6 x 5 x 118		
		2206 K C3	H 306	1	FR 62/2				
M12	1,8	1207 K C3	H 207	1	FR 72/8	M 5 x 16	FS 6 x 5 x 132		
		2207 K C3	H 307	1	FR 72/2				
		22207 K	H 307	1	FR 72/2				
M12	2,3	1208 K C3	H 208	1	FR 80/7	M 5 x 16	FS 6 x 5 x 150		
		2208 K C3	H 308	1	FR 80/2				
		22208 K	H 308	1	FR 80/2				
M12	3,0	1209 K C3	H 209	1	FR 85/6	M 6 x 20	FS 6 x 5 x 165		
		2209 K C3	H 309	1	FR 85/2				
		22209 K	H 309	1	FR 85/2				
M12	3,0	1210 K C3	H 210	1	FR 90/5	M 6 x 20	FS 6 x 5 x 180		
		2210 K C3	H 310	1	FR 90/2				
		22210 K	H 310	1	FR 90/2				
M12	4,1	1211 K C3	H 211	1	FR 100/6	M 6 x 20	FS 8 x 6,5 x 210		
		2211 K C3	H 311	1	FR 100/2				
		22211 K	H 311	1	FR 100/2				
M12	4,8	1212 K C3	H 212	1	FR 110/8	M 6 x 20	FS 8 x 6,5 x 225		
		2212 K C3	H 312	1	FR 110/2				
		22212 K	H 312	1	FR 110/2				
M12	5,9	1213 K C3	H 213	1	FR 120/10	M 6 x 20	FS 8 x 6,5 x 240		
		2213 K C3	H 313	1	FR 120/2				
		22213 K	H 313	1	FR 120/2				

\*1 to 722513: 3 screws  
ex 722515: 4 screws

# Flange Bearing Housings 722500

for bearings with adapter sleeve fastening

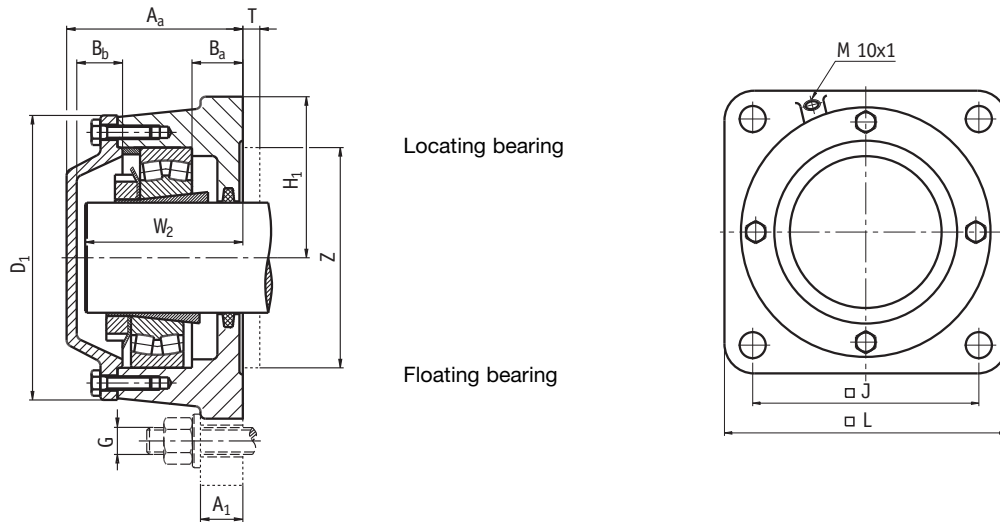

Design A  
Housing design for shaft ends

shaft d	bearing housing code number	dimensions [mm]												
		A <sub>a</sub>	A <sub>b</sub>	A <sub>1</sub>	B <sub>a</sub>	B <sub>b</sub>	D <sub>1</sub>	H	H <sub>1</sub>	J	L	W <sub>2</sub>	T*	Z*
65	722515 A	104	104	25	30	27	168	-	95	152	190	86	10	130
	722515 B					-						-		
70	722516 A	110	110	25	31	30	176	-	98	152	196	92	10	130
	722516 B					-					-			
75	722517 A	114	114	25	31	30	188	-	105	170	210	96	10	140
	722517 B					-					-			
80	722518 A	118	118	25	30	34	198	-	105	170	210	99	10	150
	722518 B					-						-		
90	722520 A	127	127	30	30	35	224	-	125	198	250	107	10	170
	722520 B					-								
100	722522 A	137	137	30	30	38	246	-	135	219	270	115	10	200
	722522 B					-						-		

\* Housings are also available with centring on the mating surface.



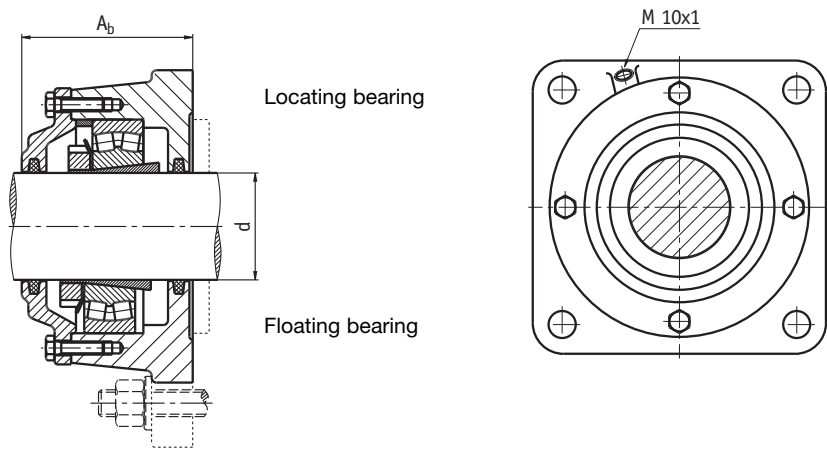

Design B  
Housing for through shafts

fastening G	weight approx. kg	suitable bearing	mounting parts		code number	cover bolts *1 DIN 7991	felt strips DIN 5419 F2	housing design
			adapter sleeves	locating rings number				
M16	9,4	1215 K C3	H 215	2	FR 130/8	M 8 x 25	FS 8 x 6,5 x 260	
		2215 K C3	H 315	1	FR 130/10			
		22215 K	H 315	1	FR 130/10			
M 16	9,8	1216 K C3	H 216	2	FR 140/8,5	M 8 x 25	FS 9 x 7,5 x 280	
		2216 K C3	H 316	1	FR 140/10			
		22216 K	H 316	1	FR 140/10			
M 16	11,5	1217 K C3	H 217	2	FR 150/9	M 8 x 25	FS 9 x 7,5 x 300	
		2217 K C3	H 317	1	FR 150/10			
		22217 K	H 317	1	FR 150/10			
M 16	12,5	1218 K C3	H 218	2	FR 160/10	M 8 x 25	FS 9 x 7,5 x 315	
		2218 K C3	H 318	1	FR 160/10			
		22218 K	H 318	1	FR 160/10			
M 20	18,0	1220 K C3	H 220	je 1	FR180/10+FR 180/12	M10 x 30	FS10 x 8,5 x 350	
		2220 K C3	H 320	1	FR 180/10			
		22220 K	H 320	1	FR 180/10			
M 20	21,5	1222 K C3	H 222	2	FR 200/12,5	M 10 x 30	FS 12 x 10 x 390	
		2222 K C3	H 322	1	FR 200/10			
		22222 K	H 322	1	FR 200/10			

\*1 to 722513: 3 screws  
ex 722515: 4 screws

# Flange Bearing Housings F 11200

for self-aligning ball bearings with widened inner ring

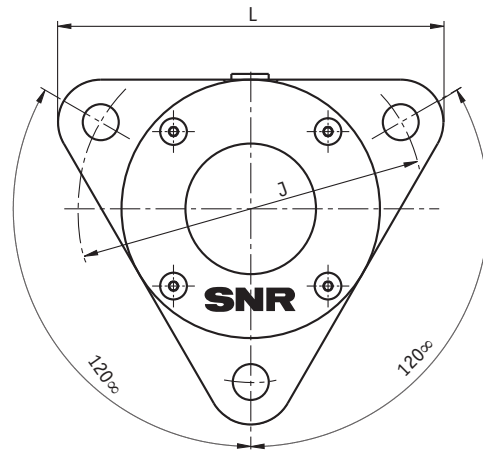

		dimensions [mm]							
shaft $d_1$	bearing housing code number	A	$A_1$	$D_a$	$D_1$	H	$H_1$	J	L
20	F 11204	42	10	29,2	67	93	35,0	90	105
25	F 11205	46	10	33,3	73	100	38,0	96	110
30	F 11206	50	12	40,1	84	117	44,0	116	130
35	F 11207	54	12	47,7	95	130	48,5	130	145
40	F 11208	60	12	54,0	105	143	54,0	140	160
45	F 11209	62	15	57,7	115	160	60,0	160	180
50	F 11210	63	15	62,7	115	160	60,0	160	180

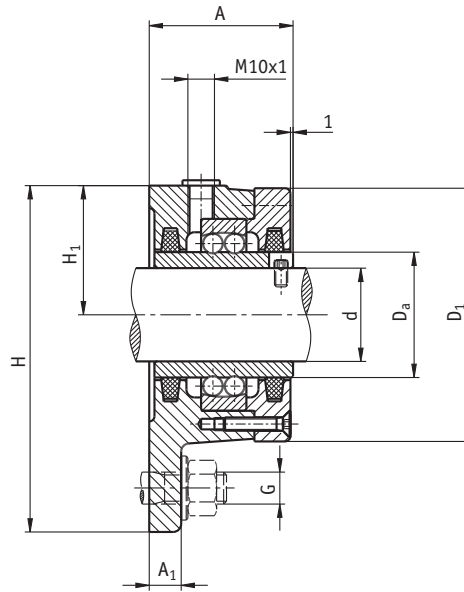

fastening G	weight approx. kg	suitable bearing	cover bolts 4 per housing DIN 7991	felt strips 2 per housing DIN 5419 F2
M10	0,8	11204	M 5 x 20	FS 6 x 5 x 132
M10	1,0	11205	M 5 x 20	FS 6 x 5 x 150
M10	1,4	11206	M 5 x 25	FS 6 x 5 x 165
M12	1,8	11207	M 5 x 25	FS 8 x 6,5 x 190
M12	2,3	11208	M 5 x 30	FS 8 x 6,5 x 225
M12	3,3	11209	M 6 x 30	FS 8 x 6,5 x 235
M12	3,6	11210	M 6 x 30	FS 8 x 6,5 x 260

# Plummer Block Housings SD 3100 TS

for bearing with adapter sleeve fastening

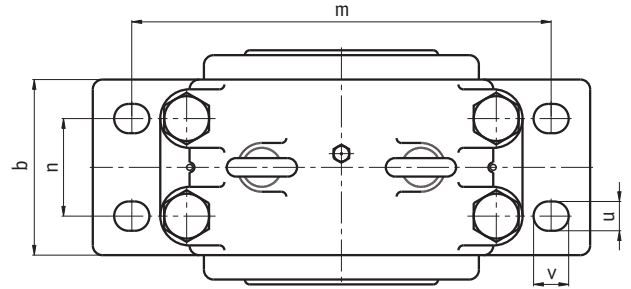
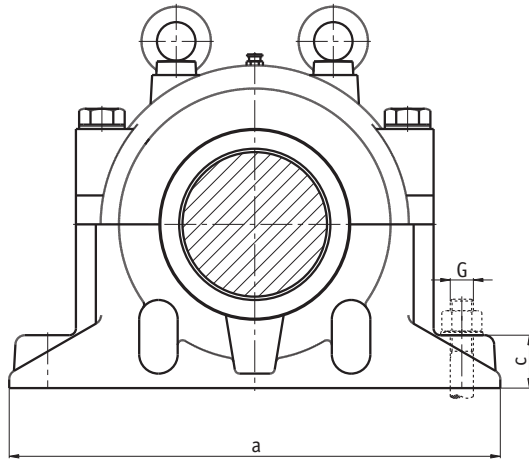

		dimensions [mm]													
shaft	bearing housing	a	b	c	e	f	h	h <sub>1</sub>	l	l <sub>1</sub>	m	n	u	v	
150	SD 3134 TSA	510	180	70	14	14	170	335	230	-	430	100	30	36	
	SD 3134 TSB									232					
160	SD 3136 TSA	530	190	75	15	15	180	355	240	-	450	110	30	42	
	SD 3136 TSB									242					
170	SD 3138 TSA	560	210	80	10	10	190	375	260	-	480	120	30	42	
	SD 3138 TSB									362					
180	SD 3140 TSA	610	230	85	10	10	210	410	280	-	510	130	37	51	
	SD 3140 TSB									282					
200	SD 3144 TSAF	640	240	90	12	12	220	435	290	-	540	140	37	51	
	SD 3144 TSAL									-					
	SD 3144 TSBF									292					
	SD 3144 TSBL									292					
220	SD 3148 TSAF	700	260	95	12	12	240	475	310	-	600	150	37	51	
	SD 3148 TSAL									-					
	SD 3148 TSBF									312					
	SD 3148 TSBL									312					
240	SD 3152 TSAF	770	280	100	13	13	260	515	320	-	650	160	43	60	
	SD 3152 TSAL									-					
	SD 3152 TSBF									322					
	SD 3152 TSBL									322					
260	SD 3156 TSAF	790	280	105	16	16	280	550	320	-	670	160	43	60	
	SD 3156 TSAL									-					
	SD 3156 TSBF									322					
	SD 3156 TSBL									322					
280	SD 3160 TSAF	830	310	110	22	22	300	590	350	-	710	190	43	60	
	SD 3160 TSAL									-					
	SD 3160 TSBF									352					
	SD 3160 TSBL									352					

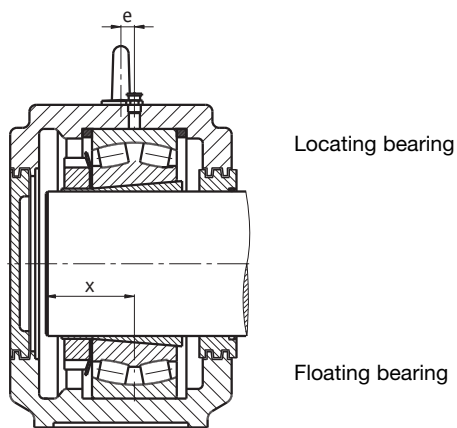

Design A  
Housing for shaft ends

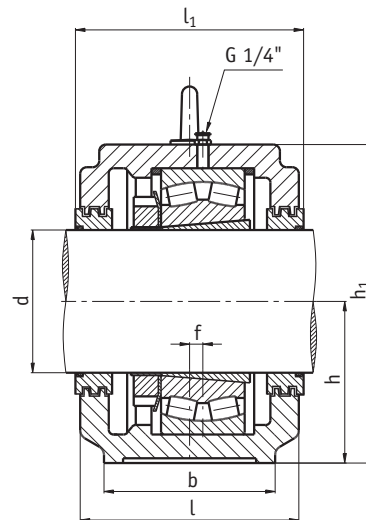

Design B  
Housing for through shafts

fastening and mounting G	X	housing weight ca. kg	suitable bearing	bearing housing equipment				grease quantity* [kg]
				Adapter sleeve	locating ring number	Code number	labyrinth ring cover	
M 24	65	70	23134 K	H 3134	2	FR 280/10	TS 34 TSA 34	1,8
M 24	68	72	23136 K	H 3136		FR 300/10	TS 36 TSA 36	2,0
M 24	80	88	23138 K	H 3138	2	FR 320/10	TS 38 TSA 38	2,7
M 30	82	122	23140 K	H 3140	2	FR 340/10	TS 40 TSA 40	3,5
M 30	90	136	23144 K	H 3144	2	FR 370/10	TS 44 TSA 44	4,2
M 30	100	190	23148 K	H 3148	2	FR 400/10	TS 48 TSA 48	5,2
M 36	105	238	23152 K	H 3152	2	FR 440/10	TS 52 TSA 52	6,6
M 36	105	252	23156 K	H 3156	2	FR 460/10	TS 56 TSA 56	7,1
M 36	110	290	23160 K	H 3160	2	FR 500/10	TS 60 TSA 60	10,2

\* fill-up quantity at initial fill (approx. 60% of cavity)

# Plummer Block Housings SD 3100 TS

for bearing with adapter sleeve fastening

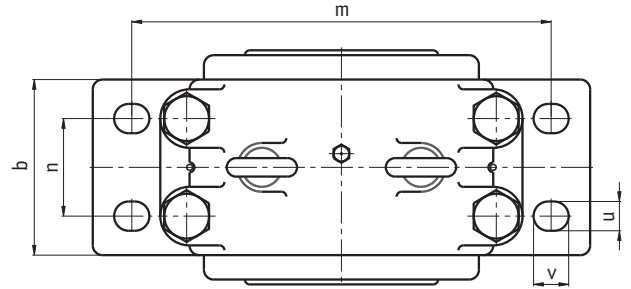
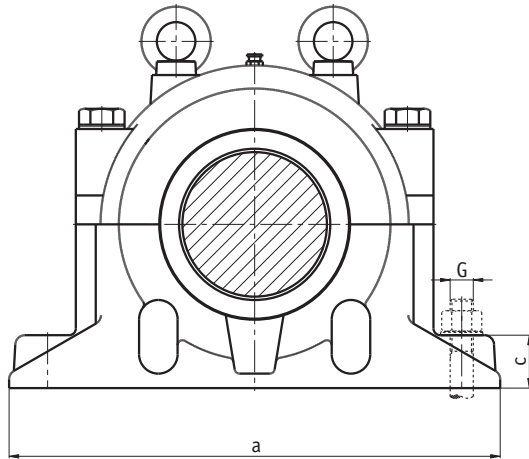

		dimensions [mm]													
shaft	bearing housing	a	b	c	e	f	h	h <sub>1</sub>	l	l <sub>1</sub>	m	n	u	v	
d	code number														
300	SD 3164 TSAF	880	330	115	23	23	320	630	370	-	750	200	43	60	
	SD 3164 TSAL									-					
	SD 3164 TSBF									372					
	SD 3164 TSBL									372					
320	SD 3168 TSAF	950	360	120	24	24	340	675	400	-	810	220	43	62	
	SD 3168 TSAL									-					
	SD 3168 TSBF									402					
	SD 3168 TSBL									402					
340	SD 3172 TSAF	1000	360	120	30	30	350	695	400	-	840	220	43	62	
	SD 3172 TSAL									-					
	SD 3172 TSBF									402					
	SD 3172 TSBL									402					
360	SD 3176 TSAF	1040	360	120	30	30	360	715	400	-	870	220	43	62	
	SD 3176 TSAL									-					
	SD 3176 TSBF									402					
	SD 3176 TSBL									402					
380	SD 3180 TSAF	1120	390	125	30	30	380	755	430	-	950	240	50	70	
	SD 3180 TSAL									-					
	SD 3180 TSBF									432					
	SD 3180 TSBL									432					
400	SD 3184 TSAF	1170	420	130	35	35	410	810	460	-	1000	260	50	70	
	SD 3184 TSAL									-					
	SD 3184 TSBF									462					
	SD 3184 TSBL									462					

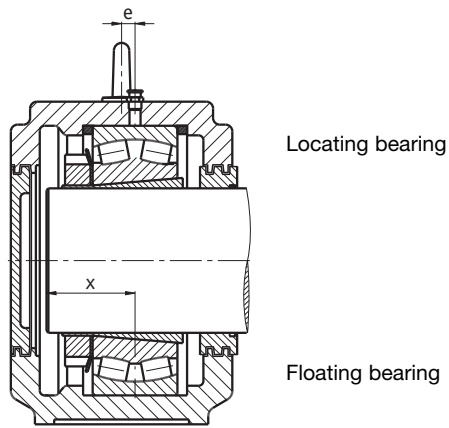

Design A  
Housing for shaft ends

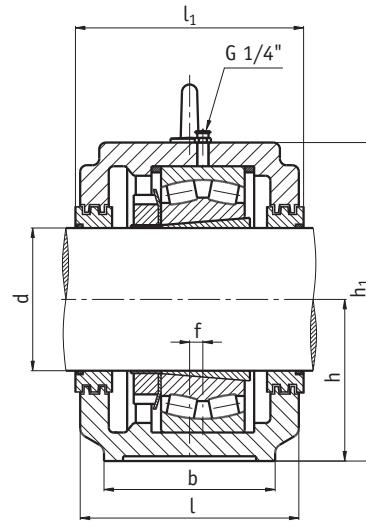

Design B  
Housing for through shafts

fastening and mounting G	X	housing weight ca. kg	suitable bearing	bearing housing equipment			labyrinth ring	cover	grease quantity* [kg]
				Adapter sleeve	locating ring number	Code number			
M 36	120	340	23164 K	H 3164	2	FR 540/10	TS 64	TSA 64	12,2
M 36	155	380	23168 K	H 3168	2	FR 580/10	TS 68	TSA 68	18,5
M 36	160	420	23172 K	H 3172	2	FR 600/10	TS 72	TSA 72	19,0
M 36	165	490	23176 K	H 3176	2	FR 620/10	TS 76	TSA 76	23,5
M 42	170	570	23180 K	H 3180	2	FR 650/10	TS 80	TSA 80	24,0
M 42	190	610	23184 K	H 3184	2	FR 700/10	TS 84	TSA 84	31,0

\* fill-up quantity at initial fill (approx. 60% of cavity)



# Bearing Housings

## Special solutions

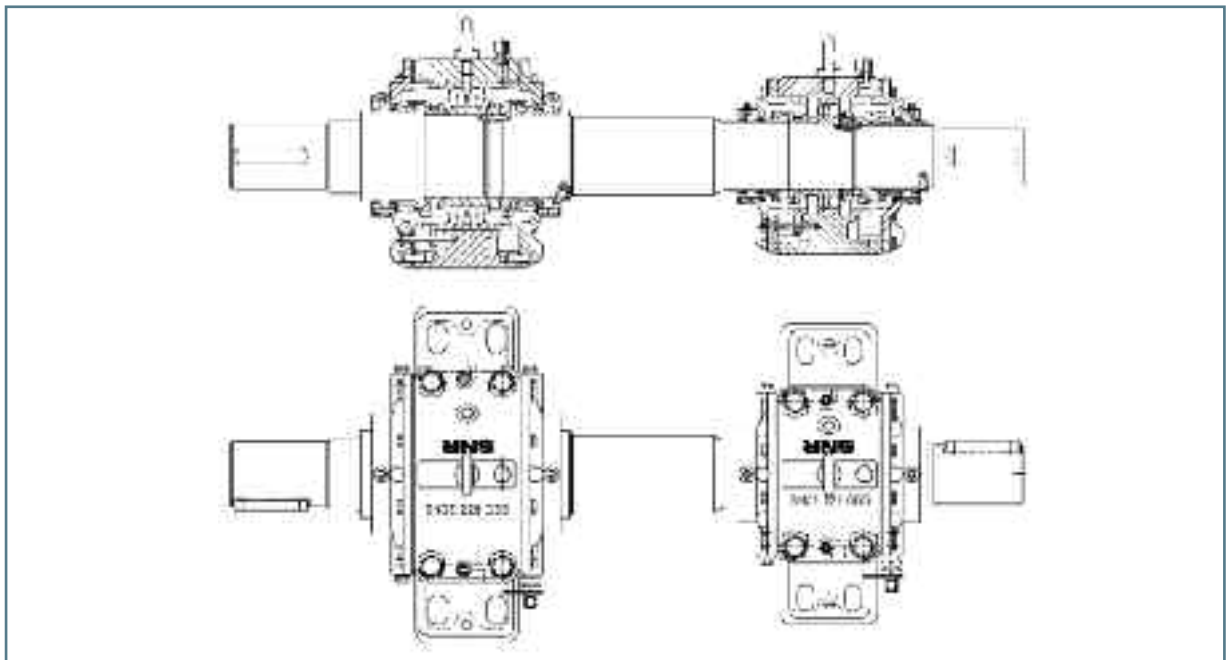
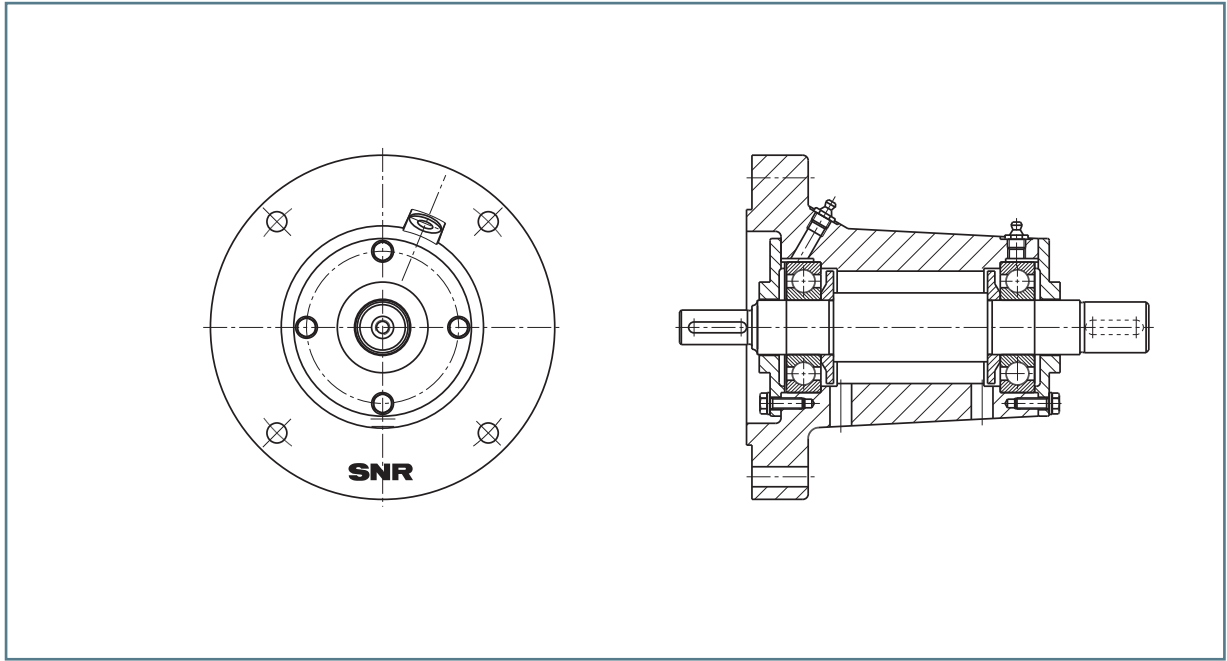

As you can see the SNR service not only extends to bearing design, but also on complete bearing units, i.e. completed housings with shafts mounted by us!



## | Auxiliary range

### **Automatic lubricator**

With the introduction of SNR grease bushings bearing faults caused by lack of grease or excess grease are now a thing of the past. A manually adjustable, constant grease volume supply ensures every bearing position operates perfectly for up to twelve months.

The grease bushing is available with all SNR standard greases. It is explosion-proof and can be mounted into any position.

More information about this can be found in the SNR Maintenance Services catalogue.

### **SNR LUB greases**

The SNR Maintenance catalogue provides you with information on the most important technical and physical properties of the SNR standard grease.

It makes it easier for you to select a lubricant for your particular application.

### **SNR induction heating devices**

With these devices the operator can heat bearing inner rings quickly and reliably. The heating process enables easier mounting and increases the service life of the bearings.

Even sealed and greased bearings can be heated with the aid of induction heating devices.

SNR offers different devices for various sizes of bearings.

### **SNR bearings in PREMIER quality**

SNR PREMIER self-aligning roller bearings are designed for applications in which high loads, severe imbalance, dirt, shocks and vibrations can occur. To improve on the excellent performance and reliability of the series, the SNR PREMIER self-aligning roller bearings have been optimised in terms of their load ratings and service life. By using high-purity steels, optimizing the internal construction and improving the manufacturing methods, the load ratings have been successfully increased by 18%, bringing a 75% rise in the service life.

| To find out more about SNR's PREMIER quality self-aligning roller bearings, ask for your catalogue.

### **SNR special bearings / -systems**

Next to our varied standard range we also develop special bearings and bearing systems in close coordination with our customers from every branch of industry. Therefore we use non-standard materials or change housing designs after customer requirements.



# SNR : BEARING HOUSINGS

There is a great variety of bearing housing applications in the field of machine- and plant engineering. In most cases technical requirements and environmental conditions influence the design of the housing, the choice of the bearing and specification of the sealing system. The wide assortment of SNR bearing housings offers always an adequate and efficient solution for the installation in your machinery.

