DODGE GEARING CATALOG

QUICK REFERENCE	REFERENCE GUIDE
TORQUE-ARM™	G1
TORQUE-ARM II.	G2
MAXUM®	G3
TIGEAR-2™	G4
COMBINATION TIGEAR	G5
ENGINEERING	G6
SYSTEM-1	G7
PART NUMBER INDEX	INDEX-1
KEYWORD INDEX	INDEX-27

REFERENCE GUIDE

TORQUE-ARM II Shaft Mount Reducers Page G1-1



- 12 new reducer sizes with modular accessories
- All reducers can be shaft mounted, screw conveyor, vertical, and flange mounted
- Up through 400 HP
- Torque ratings through 500,000 lb-in
- Standard 5, 9, 15, 25, and up to 40:1 gear ratios
- Nearly 300:1 speed reduction with V-belt drives
- Bushing bores: 1" through 7"
- All-new, highly efficient helical gearing design
- Meets or exceeds AGMA standards, including 5000 hours L10 life and 25,000 average life
- New metal shield sealing system with excluder lip
- Smooth, rugged Class 30 cast-iron housings with pry slots
- New 36-month/18-month warranty protection

TXT TORQUE-ARM Shaft Mount Reducers Page G2-1



- Exclusive twin tapered bushings
- Rugged cast-iron efficient housing
- Precision, high-quality helical gearing
- Reliable anti-friction bearings and seals
- Efficient splash lubrication
- Meets/exceeds AGMA standards
- 100% factory noise and leak tested

Capabilities & Mounting

- Standard ratios: 5, 9, 15, and 25:1
- Ratios up to 210:1 with V-belts
- Fractional to 700 HP
- Output speeds through 400 RPM
- Optional flange mount and vertical shaft application
- Available with hydraulic motor input

Accessories

- Motor mounts
- Bushing assemblies
- Backstops
- Auxiliary seal kits
- Belt guards
- Cooling fans
- Harsh duty accessories

SCXT Screw Conveyor Shaft Mount Reducers Page G2-81



- Industry standard, high quality, drive mounting
- Adapter conforms to any CEMA trough ends
- Sealing system alternatives in standard adapter
 - Seals
 - Waste packing
 - Braided felt seal
- Rugged, high-thrust roller bearings
- Conforms to CEMA standards
- CEMA high-strength shafts, 2- and 3-bolt

Capabilities

- Fractional to 75 HP
- Standard ratios: 5, 9, 15, and 25:1
- 1-1/2" to 3-7/16" CEMA drive shafts
- Output speeds through 400 RPM
- Available with hydraulic motor input
- Vertical and incline mounting capability

Accessories

- Standard C and adjustable packing gland adapters
- Drive shafts - standard steel and stainless steel
- Motor mounts
- Belt guards
- Auxiliary seal kits
- Cooling fans

MAXUM Concentric Speed Reducers

Page G3-1

- Compact, power-dense design
- Precision-machined, cast-iron housing
- Highly efficient AGMA-rated helical gearing
- Heavy duty tapered roller bearing design
- Metallic double-lip seals—input/output
- Full line of accessories available
- SO 9002 certified

Features

- 8 sizes
- Fractional to 1600 HP
- Ratios: 2.25 to 194.6
- Up to 502,000 (in-lb) torque
- Mounting flexibility
 - Direct coupled
 - Top mount
 - Scoop mount
 - Heavy duty base plate

Accessories

- Backstops
- Slide base
- Cooling fans
- Auxiliary seal kits
- Heat exchanger cooling package
- Paint options
- XT filter breather
- XT enclosed breather
- XT Impro machine seal
- Coupling and belt guards
- Oil sight gauge
- Sensor devices



TIGEAR-2 Speed Reducers

Page G4-1

- Single-worm with quill, separate or 3-piece coupled input
- Totally enclosed, ventless design that is maintenance free
- 10 case sizes 1.33" to 4.75" center distances
- 5:1 to 60:1 reductions
- Solid or hollow output
- GRIP TIGHT bushing system available
- E-Z KLEEN design available
- Cast iron construction that is durable and corrosion resistant
- Factory filled with synthetic lubricant



Combination TIGEAR Speed Reducers

Page G5-1

- Worm-helical, three-piece-coupled, C-face design
- Cast-iron construction with a low profile; compact design fits in close quarters
- Replaces large center distance worm drives
- Second-stage helical reduction provides high efficiency
- Hollow bore output available with DODGE twin tapered bushings
- Factory filled with synthetic lubricant
- •1/4 to 10 HP
- •10:1 to 303:1 reductions
- Four case sizes: 150, 200, 262, and 350
- Available with either hollow or solid output
- E-Z KLEEN design available





TORQUE-ARM II Shaft Mount Speed Reducers

Features/Benefits	G1-3
Specifications	G1-7
Nomenclature	G1-8
Easy Selection	G1-9
Selection	
Application and Class Numbers	G1-12
Class I Selections	G1-15
Class II Selections	G1-22
Class III Selections	G1-29
Selection/Dimensions	
TA0107L	
Taper Bushed Reducers and Accessories	G1-36
Screw Conveyor Drive Reducers and Accessories	G1-38
Motor Mount Dimensions	G1-40
TA1107H	
Taper Bushed Reducers and Accessories	G1-44
Screw Conveyor Drive Reducers and Accessories	G1-46
Motor Mount Dimensions	G1-48
TA2115H	
Taper Bushed Reducers and Accessories	G1-52
Screw Conveyor Drive Reducers and Accessories	G1-54
Motor Mount Dimensions	G1-56
TA3203H	
Taper Bushed Reducers and Accessories	G1-60
Screw Conveyor Drive Reducers and Accessories	G1-62
Motor Mount Dimensions	G1-64
TA4207H	
Taper Bushed Reducers and Accessories	G1-68
Screw Conveyor Drive Reducers and Accessories	G1-70
Motor Mount Dimensions	G1-72
TA5215H	
Taper Bushed Reducers and Accessories	G1-76
Screw Conveyor Drive Reducers and Accessories	G1-78
Motor Mount Dimensions	G1-80
TA6307H	
Taper Bushed Reducers and Accessories	G1-84
Screw Conveyor Drive Reducers and Accessories	G1-86
Motor Mount Dimensions	G1-88
TA7315H	
Taper Bushed Reducers and Accessories	G1-92
Screw Conveyor Drive Reducers and Accessories	G1-94
Motor Mount Dimensions	G1-96
TA8407H	
Taper Bushed Reducers and Accessories	G1-100
Motor Mount Dimensions	G1-102

CONTENTS



TORQUE-ARM II Shaft Mount Speed Reducers

Selection/Dimensions (Continued)

TA9415H	
Taper Bushed Reducers and Accessories	G1-106
Motor Mount Dimensions	G1-108
TA10507H	
Taper Bushed Reducers and Accessories	G1-110
Motor Mount Dimensions	G1-112
TA12608H	
Taper Bushed Reducers and Accessories	G1-114
Motor Mount Dimensions	G1-116
Belt Guard Dimensions - TA0107L - TA12608H	G1-118
Cooling Fan Dimensions - TA4207H - TA12608H	G1-122
Reducer Auxiliary Cooling Package	G1-122

Related Products

XT Harsh Duty Accessories	G1-123
Maximum Bore Straight Bore TA II Reducers	G1-124
Nominal Sheave Ratios	G1-125
Nominal Sheave Speeds	G1-127

Renewal Parts	G1-128
-------------------------	--------

Engineering/Technical

NEMA Motor and TA II Reducer Information, Backstop Lift-off Speed	G1-129
Maximum Input and Output Speeds	G1-130
Thrust Capacity for Screw Conveyor Drives	G1-131
Lubrication Information	G1-132
Bearing Life As Function of Service Factor	G1-138

Part Number Index	INDEX-1
-----------------------------	---------

Keyword Index	INDEX-27
-------------------------	----------



FEATURES/BENEFITS

TORQUE-ARM II Shaft Mount Speed Reducers THE LEGACY CONTINUES



With 50 years of proven dependability and more than 1.5 million units in service throughout the world, DODGE TORQUE-ARM speed reducers are the standard of the industry. Now, that legacy continues with the newest generation in shaft mounted speed reducers - TORQUE-ARM II - offering patented innovations, new features, plus increased torque and horsepower ratings.

FEATURES/BENEFITS



TORQUE-ARM II Shaft Mount Speed Reducers

THE LEGACY CONTINUES



Its industry proven design and new patented features are why the new DODGE TORQUE-ARM II surpasses all other reducers on the market.

This completely new line of shaft mounted speed reducers - in 12 case sizes through 700 horsepower (HP) - offers unparalleled torque ratings. An all-new backstop concept. A new patented sealing system. A totally new steel motor mount system. A state-of-the-art, totally modular design with an expanded ratio range to 40:1. And a new patented twin tapered bushing system.

The increased ratings in the new TORQUE-ARM II line are comparable to the next larger sized TXT reducer and are the result of the extended gear centers, wider gear faces, and optimized tooth geometry. The new backstop design features centrifugal lift-off sprags for extended life and can be used with lubricants containing EP additives.

In addition, the new TORQUE-ARM II line has a patent pending, premium sealing system that uses a standard lip, spring-loaded, rubber-coated oil seal protected by a patented metal excluder seal with rubbing lip.

The totally new steel motor mount adjusts to multiple center distances and mounts in shaft mount and screw conveyor positions.

The new twin tapered bushing system in standard length, patented short shaft, and metric versions offers all the features of our standard twin tapered TORQUE-ARM bushing design (unique to DODGE). An insertable tapered wedge allows the optional extended tapered bushing to mount on shorter shaft lengths.

New Modular Concept

Shaft mounted reducer with twin tapered bushing and motor mount



Screw conveyor drive with adapter, drive shaft and motor mount



PRODUCT CAPABILITIES

Twelve new reducer sizes with modular accessories

All reducers can be shaft mounted, screw conveyor, vertical and flange mounted

HP through 400, and torque ratings through 500,000 lb. in

Standard 5, 9, 15, 25 and up to 40:1 gear ratios

Nearly 300:1 speed reduction with V belt drives

Bushing bores 1 inch through 7 inches

All new highly efficient helical gearing design

Meets or exceeds AGMA standards including 5,000 hour L-10 bearing life, 25,000 average life

Smooth, rugged class 30 cast iron housings with pry slots

New 36 month - 18 month warranty protection

Complete Metric TA II product line available - see catalog RAPS-679-1

Three view CAD templates available - request RAPS-949-1

FEATURES/BENEFITS



TORQUE-ARM II Shaft Mount Speed Reducers

THE LEGACY CONTINUES

The new-generation DODGE TORQUE-ARM II has been engineered throughout with features designed to improve performance, extend service life, and reduce or simplify maintenance.

Three large pry slots make rebuilding easy.

Proven, AGMA-rated, case-carburized gear design ensures high efficiency. Has Class I starting load capability of 200%.

Totally modular construction, one reducer for shaft mount, screw conveyor, vertical and flange mount applications.



Standard metal reinforced, lip, spring-loaded oil seals are protected by patented labyrinth metal shield and excluder lip auxiliary seal on all shafts. No lubrication required. Factory tested.

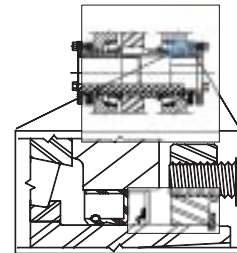

100% cast iron housing (Class 30) eliminates bearing cap leak paths and maximizes surface area for heat dissipation.

New twin tapered bushings are available in standard, patented short shaft, and metric versions.

Heavy duty tapered roller bearings provide 25,000 hours average life and 5,000 L-10 minimum hours life—even in the heaviest load conditions.

Extended gear centers and increased gear tooth contact provide dramatically increased torque and horsepower ratings.

Magnetic drain plug and baffled air breather are standard.





FEATURES/BENEFITS

TORQUE-ARM II Shaft Mount Speed Reducers

THE LEGACY CONTINUES MODULAR ACCESSORIES

Shaft Mounted



STANDARD TWIN TAPERED BUSHING SYSTEM is an easy on, easy off, no-wobble bushing system featuring a fully split, ductile iron 8° taper and reliable twin support. Available in inch

and metric bores. Increased bore capability in many sizes.



Our new **SHORT-SHAFT TWIN-TAPERED BUSHING KITS** eliminate the need for full-length shafts. Constructed with ductile iron, it has all the features of our standard

bushing system. Available in both inch and metric bores.



This new **MODULAR MOTOR MOUNT** is attached and supported by two angle iron brackets with equally spaced holes, which align with the spacing of the cast slots of the gear case. This way, the motor mount can be adjusted up or down depending on the customer's requirements. It can

also be mounted on the side of the reducer for screw conveyor applications.



This new **BACKSTOP** option helps prevent reverse rotation in high stop-start loads, and results in less wear and longer life. Its centrifugal throw-out design eliminates sprag sliding and reduces wear. It operates with standard and EP lubricants and requires no external lubrication.

Ruggedly constructed, the **TA ROD KIT** includes standard brackets, functions as a belt-tensioning device, and offers universal mounting options.



Screw Conveyor

The new **CEMA BOLT-ON ADAPTER** features double-lip seals on both surfaces. The adapter center is open for contaminate drop out for optimized sealing.

An optional **ADJUSTABLE PACKING KIT** bolts to the standard adapter and provides a proven sealing option for hostile environments. Packing can be retightened.



The **SCREW CONVEYOR DRIVE SHAFTS** are made from high alloy steel and engineered to CEMA dimensions. They are three-bolt drilled and their tapered fit ensures simple installation. The rugged locking plate (patent pending) also provides a mechanical shaft removal feature. #316 Stainless Steel drive shafts also available.



This complete **BOLT-ON BELT GUARD PACKAGE** requires no drilling or straps. It allows multiple height adjustments, features lift-off cover construction, and has an open metal inspection feature.



Other accessories include cooling fans and vertical breather kits.



TORQUE-ARM II Shaft Mount Speed Reducers

General Specifications

TORQUE-ARM II Speed Reducers:

The speed reducer shall be either a belt driven or direct coupled enclosed shaft mount type unit with a single or double reduction ratio. The reducer shall mount directly on the driven shaft and utilize an adjustable torque arm that attaches from the gear case to the support structure or foundation. Optional all steel motor mount adjusts to various belt center distances and supports the motor.

The reducer housing shall be constructed of two piece corrosion resistant, class 30 gray iron. All housings shall be doweled and precision machined to assure accurate alignment for all gear sets. Pry slots are provided for ease of repair.

All gearing shall be of helical design, and crown shaved to provide an ellipsoid tooth to eliminate tooth end bearing and assure meshing at the strongest tooth area. All gears shall be case carburized and precision finished to insure a high surface durability with a resilient tooth core for impact resistance and optimum service life. Gears shall be supported between bearings to maintain proper alignment of gear meshes, maximize load carrying capabilities, and to eliminate overhung

loads imposed on bearings. Design meets or exceed AGMA standards.

Reducer bearings shall be of the tapered roller type, meet or exceed AGMA standards, and provide a 25,000 hour average life as a minimum. (5,000 L-10)

All seals shall be of the lip, spring loaded type, made of nitrile rubber and have rubber coated outside diameters. A metal excluder seal with rubber lip is external to the standard oil seal.

Reducer installation shall be accomplished by using ductile iron, fully split, standard Twin Tapered Bushings. Reducer removal shall be accomplished by providing jack screw holes in the bushing flanges to mechanically remove the tapered assembly.

Backstops should be lift-off sprag type and suitable for use with standard petroleum and extreme pressure (EP) lubricants.

Screw Conveyor Drives:

The drive shall consist of a standard speed reducer; a cast iron, bolt on, four bolt mounting adapter with double lip seals on both ends, and optional bolt on adjustable packing kit. Three hole drive shaft are machined from a high quality alloy

steel. The drive shall conform to Conveyor Equipment Manufacturers Association (CEMA) standards. Optional all steel motor mount adjusts to various belt center distances and supports the motor.

FEATURES/BENEFITS PAGE G1-3	NOMENCLATURE PAGE G1-8	SELECTION/DIMENSIONS PAGE G1-36	RELATED PRODUCTS PAGE G1-123
--------------------------------	---------------------------	------------------------------------	---------------------------------



NOMENCLATURE

TORQUE-ARM II Shaft Mount Speed Reducers

Basic TORQUE-ARM II Reducer TA1107H25

Shaft Mount Reducer Drive Accessories

TA1107RA

TA1107 Rod Assembly

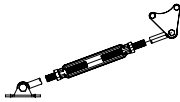

TA1107TB x 1-7/16

TA1107TB x 1-7/16 Twin Tapered Bushing Kit for Standard Length Driven Shaft

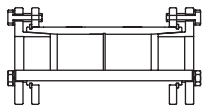

TA1107TBS x 1-7/16

TA1107TBS x 1-7/16 Twin Tapered Bushing Kit for Short Driven Shaft

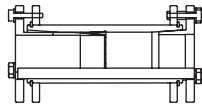

TA1107MM

TA1107MM Motor Mount Assembly

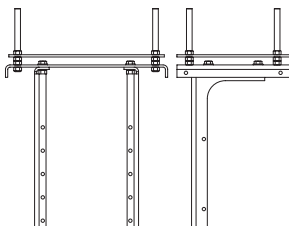

TA - TORQUE-ARM II Shaft Mount Reducer
1 - Case Size 1

107 - AGMA Code reference & Traditional Bore Size

H - Heavy Duty Rating & Extended Bore Size

25 - Nominal Reducer Ratio

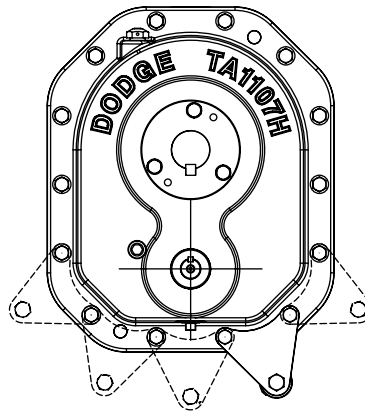

Other Accessories

TA1107BS

Backstop Assembly



TA4207CF

Cooling Fan Assembly

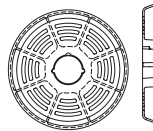

TA1-4 FB Kit

Filter Breather Kit



Screw Conveyor Drive Accessories

TA1107SCA

TA1107SCA Screw Conveyor Standard Adapter & Hardware Kit (does not include shaft)

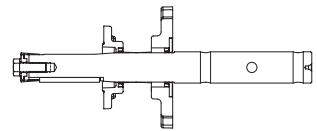

TA1107SCP Kit

TA1107SCP Screw Conveyor Adjustable Packing Kit (does not include shaft or adapter)

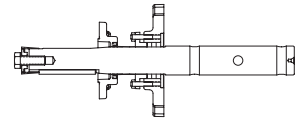

TA1107SCS x 1-7/16

TA1107SCS Screw Conveyor Drive Shaft x 1-7/16" Diameter

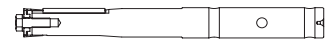

TA1107BG

TA1107BG Belt Guard

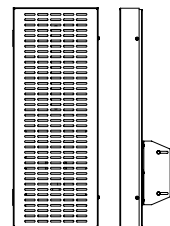

FEATURES/BENEFITS
PAGE G1- 3

SPECIFICATION
PAGE G1- 7

SELECTION/DIMENSIONS
PAGE G1- 36

RELATED PRODUCTS
PAGE G1- 123



TORQUE-ARM II Shaft Mount Speed Reducers

EASY SELECTION METHOD (FOR ELECTRIC MOTORS) FOR TORQUE-ARM II REDUCER AND SCREW CONVEYOR DRIVE REDUCER APPLICATIONS

When to Use Easy Selection

The Easy Selection tables for TA II Shaft Mount reducers are for electric motor selections up to 400 horsepower with output speeds up to 400 RPM, using AGMA recommended application class numbers. For extreme shock or high energy loads which must be absorbed, as when stalling; for a power source other than an electric motor; or for extreme ambient temperatures or oversized equipment, consult DODGE Application Engineering, 864-288-9050.

How to Select

Step 1: Determine Class of Service - See Table 1 to determine Load Classification for applications under normal conditions. Find the type application and duty cycle that most closely matches your specific application.

Class 1 - Steady load not exceeding Motor HP rating and light shock loads during 10 hours a day. Moderate shock loads are allowable if operation is intermittent.

For Class 1 applications, the maximum value of starting and momentary peak loads should not exceed 2 x Motor HP rating. If it exceeds this amount it should be divided by 2 and the result used in the selection table instead of the Motor HP rating.

Class 2 - Steady load not exceeding Motor HP rating for over 10 hours a day. Moderate shock loads are allowable during 10 hours a day.

For Class 2 applications, the maximum value of starting and momentary peakloads should not exceed 2.8 x Motor HP rating. If it exceeds this amount it should be divided by 2.8 and the result used in the selection table instead of the Motor HP rating.

Class 3 - Moderate shock loads for over 10 hours a day. Heavy shock loads are allowable during 10 hours a day.

For Class 3 applications, the maximum value of starting and momentary peak loads should not exceed 4 x Motor HP rating. If it exceeds this amount it should be divided by 4 and the result used in the selection table instead of the Motor HP rating.

Step 2: Determine Reducer Size - See the Easy Selection Tables, pages G1-12- G1-34. From Class I, II or III

Table, find the reducer size for the application horsepower and output speed.

Note: For applications where fan cooling is unacceptable, use the Easy Selection tables with an increased Class of Service number. Where more than one reducer selection is listed, the most economical ratio is generally listed first. See Engineering/Technical pages for maximum input speed, output speed, and thrust capacity ratings for TA II reducers.

Step 3: Compare Hollow Shaft Bore with the size of the driven shaft. All DODGE TA II Taper Bushed reducers require bushings to mount reducer to driven shaft. Refer to reducer pages for available bushings. If the driven shaft is larger than the bore of the selected reducers, the shaft must be machined to the proper size, or select a larger reducer. Check driven shaft and key for strength.

Step 4: Check Dimensions - See Selection/Dimension pages for reducer dimensions, weights, part numbers and Torque-Arm rod mounting positions. See Engineering/ Technical pages for reducer mounting positions.

Step 5: Select a Belt Drive Arrangement - From the Sheave ratio information, pages G1-125 thru G1-126, select a sheave ratio for the belt drive. The reducer sheave P.D., Pitch Diameter, should not be smaller than the minimum sheave diameter shown in the selection tables. Note: Mount the sheave as close as possible to the reducer to minimize the effect of overhung load on the reducer.

See DODGE Drives Components catalog to select sheaves, bushings and belts for the appropriate belt drive.

Step- 6: Select Accessories - See Selection/Dimensions pages for description, dimensions, weights and part numbers for accessories for the TA II reducer selected:

- Rod Assembly** **Bushing Kit** **Motor Mount**
- Cooling Fan** **Backstop Assembly** **Belt Guard**
- Screw Conveyor Adapter** **Filter Breather**
- Drive Shaft** **Adjustable Packing Kit**
- Vertical Breather Kit**

FEATURES/BENEFITS PAGE G1-3	NOMENCLATURE PAGE G1-8	SELECTION/DIMENSIONS PAGE G1-36	RELATED PRODUCTS PAGE G1-123
--------------------------------	---------------------------	------------------------------------	---------------------------------



EASY SELECTIONS

TORQUE-ARM II Shaft Mount Speed Reducers

EASY SELECTION METHOD (FOR ELECTRIC MOTORS) FOR TORQUE-ARM II REDUCER AND SCREW CONVEYOR DRIVE REDUCER APPLICATIONS

Note: IMPORTANT INFORMATION

TA II reducers are stocked without a Torque-Arm Rod Assembly. Order a TA Rod Assembly as a separate item.

TA II reducers are shipped without oil. They must be lubricated at time of installation.

TA II reducers are suitable, from stock, for vertical or incline mounting and flange mounting; no reducer modification is required. See accessories for vertical breather kit.

TA II Backstop - For best life, select reducer gear ratios which exceed input shaft speeds required for backstop sprag lift-off. See page G1-129 for Backstop Lift-off speeds.

WARNING: Backstops are not recommended for applications involving energy absorption and shock or torque loads in excess of reducer ratings or on applications such as chair lift, amusement rides, etc., where the safety of persons or property is dependent on their function. On such applications, other safety devices should be provided.

Note: The TA II reducer has built-in auxiliary sealing which gives extra seal protection for all environments, at no additional cost to the user. See the Feature/Benefits pages for details.

Example: Easy Selection method for TORQUE-ARM II Reducers - Shaft Mount and Screw Conveyor Drive

Shaft Mount Reducer Application:

A 10 HP 1750 RPM motor is used to drive a belt conveyor moving sand at 70 RPM. The conveyor is uniformly loaded and operates 16 hours per day. The head pulley shaft diameter is 2-3/16". The user specifications call for a means of holding the conveyor from moving backwards.

Step 1: Determine Class of Service - From Table 1 on page G1-12 locate the appropriate application, "belt conveyors, uniformly loaded or fed" for over 10 hours per day. This load is classified as a Class II application.

Step 2: Determine Reducer Size - From Class II Selection, page G1-22, find the column for 10 HP and read down to 70 RPM. A reducer size TA3203H25 or TA3203H15 reducer is the correct selection. See Engineering/Technical pages to compare input and output speed and overhung load application requirements with reducer ratings.

Step 3: Compare Hollow Shaft Bore of a size TA3203H25 or TA3203H15 with the head pulley shaft diameter. Per page G1-60, 2-3/16" is the maximum bore available for this size of reducer. It will work in this application. Be sure to check the driven shaft and key for strength.

Step 4: Check Dimensions and Weights - See Selection/Dimension pages for reducer dimensions, weights, part numbers and other pertinent drive dimensions, as well as information on TORQUE-ARM rod mounting positions. See Engineering/Technical pages for information on reducer mounting positions.

Step 5: Select a Belt Drive - From the Sheave Ratio information, pages G1-125 thru G1-126, select a belt drive ratio for the conveyor speed of 70 RPM. Then select a belt drive, from the DODGE Drive components catalog, that meets the customer's needs (service factor, minimum number of belts) and preferences (belt style, bushing mounting style, etc.) The sheave diameters must not be smaller than the minimum diameters shown in the selection tables.

Step 6: Select Accessories - See Selection/Dimensions pages to pick out accessories for this application:

TA3203BS Backstop Assembly, to hold the conveyor from moving backwards

TA3203MM Motor Mount Assembly, for top mounting the motor to the reducer.

TA3203BG - Pos. B Belt Guard, to cover and protect the rotating belt drive.

FEATURES/BENEFITS PAGE G1-3	NOMENCLATURE PAGE G1-8	SELECTION/DIMENSIONS PAGE G1-36	RELATED PRODUCTS PAGE G1-123
--------------------------------	---------------------------	------------------------------------	---------------------------------



TORQUE-ARM II Shaft Mount Speed Reducers

EASY SELECTION METHOD (FOR ELECTRIC MOTORS) FOR TORQUE-ARM II REDUCER AND SCREW CONVEYOR DRIVE REDUCER APPLICATIONS

Example: Easy Selection method for TORQUE-ARM II Reducers - Shaft Mount and Screw Conveyor Drive

Screw Conveyor Drive Reducer Application:

A 5 HP 1750 RPM motor is used to drive a heavy duty screw conveyor moving at 72 RPM. The conveyor runs 10 hours per day in a local feed mill conveying grain. The user needs a reducer drive compatible with a CEMA 12" diameter screw and a 2-7/16" diameter drive shaft.

Step 1: Determine Class of Service - From Table 1 on page G1-12 locate the appropriate application, "conveyors, general purpose; screw conveyor - heavy duty, not uniformly loaded" for 3 to 10 hours per day. This load is classified as a Class II application.

Step 2: Determine Reducer Size - From Class II Selection Table, page G1-22, find the column for 5 HP and read down to 72 RPM. A TA1107H25 reducer is the correct selection. See Engineering/Technical pages to compare input and output speed and overhung load application requirements with reducer ratings.

Step 3: Check Dimensions - See Selection/Dimensions pages for reducer dimensions, weights, part numbers and other pertinent drive dimensions. See Engineering/Technical pages for information on reducer mounting positions.

Step 4: Select Drive Shaft to fit screw diameter. See Selection/Dimension page G1-40. Here we verify that a 2-7/16" diameter drive shaft is compatible with a 12" diameter screw.

Step 5: Select a Belt Drive - From the Sheave Ratio information, pages G1-125 thru G1-126, select a belt drive ratio for the screw conveyor speed of 72 RPM. Then select a belt drive, from the DODGE Drive Components catalog, that meets the customer's needs (service factor, minimum number of belts) and preferences (belt style, bushing mounting style, etc.) The sheave diameters must not be smaller than the minimum diameters shown in the selection tables.

Step 6: Select Accessories - See Selection/Dimensions pages to pick out screw conveyor accessories for this application:

TA1107SCA Adapter & Hardware Kit, to mount reducer to trough end of screw conveyor.

TA1107SCP Adjustable Packing Kit, to add additional sealing protection to reducer drive.

TA1107MM Motor Mount Assembly, for top mounting of motor to the reducer.

TA1107BG-Pos. C Belt Guard, to cover and protect the rotating belt drive.

TA1107SCS X 2-7/16" Drive Shaft, to connect the reducer to the screw conveyor.

FEATURES/BENEFITS PAGE G1-3	NOMENCLATURE PAGE G1-8	SELECTION/DIMENSIONS PAGE G1-36	RELATED PRODUCTS PAGE G1-123
--------------------------------	---------------------------	------------------------------------	---------------------------------

SELECTION



TORQUE-ARM II Shaft Mount Speed Reducers

Table 1: APPLICATION CLASSIFICATION AND CLASS NUMBERS

Application	Class Numbers	
	3 to 10 Hrs per Day	Over 10 Hrs per Day
AGITATORS (Mixers)		
Pure Liquids	I	II
Liquids and Solids	II	II
Liquids-Variable Density	II	II
BLOWERS		
Centrifugal	I	II
Lobe	II	II
Vane	II	II
BREWING AND DISTILLING		
Bottling Machinery	I	II
Brew Kettles-Continuous Duty	II	II
Cookers-Continuous Duty	II	II
Mash Tubs-Continuous Duty	II	II
Scale Hopper-Frequent Starts	II	II
CAN FILLING MACHINES	I	II
CAR DUMPERS	III	III
CAR PULLERS	II	II
CLARIFIERS	I	II
CLASSIFIERS	II	II
CLAY WORKING MACHINERY		
Brick Press	III	III
Briquette Machine	III	III
Pug Mill	II	II
COMPACTORS	★	★
COMPRESSORS		
Centrifugal	I	II
Lobe	II	II
Reciprocating, Multi-Cylinder	II	III
Reciprocating, Single-Cylinder	III	III
CONVEYORS-GENERAL PURPOSE		
Includes Apron, Assembly, Belt, Bucket, Chain, Flight, Oven and Screw		
Uniformly Loaded or Fed	I	II
Heavy Duty-Not Uniformly Fed	II	II
Severe Duty-Reciprocating or Shaker	III	III
CRANES	★	★
CRUSHER		
Stone or Ore	III	III
DREDGES		
Cable Reels	II	II
Conveyors	II	II
Cutter Head Drives	III	III
Pumps	III	III
Screen Drives	III	III
Stackers	II	II
Winches	II	II

Application	Class Numbers	
	3 to 10 Hrs per Day	Over 10 Hrs per Day
ELEVATORS		
Bucket	II	II
Centrifugal Discharge	I	II
Escalators	I	II
Freight	II	II
Gravity Discharge	I	II
EXTRUDERS		
General	II	II
Plastics		
Variable Speed Drive	III	III
Fixed Speed Drive	III	III
Rubber		
Continuous Screw Operation	III	III
Intermittent Screw Operation	III	III
FANS		
Centrifugal	I	II
Forced Draft	II	II
Induced Draft	II	II
Industrial & Mine	II	II
FEEDERS		
Apron	II	II
Belt	II	II
Disc	I	II
Reciprocating	III	III
Screw	II	II
FOOD INDUSTRY		
Cereal Cooker	I	II
Dough Mixer	II	II
Meat Grinders	II	II
Slicers	II	II
GENERATORS AND EXCITERS	II	II
HAMMER MILLS	III	III
HOISTS	★	★
LAUNDRY TUMBLERS	II	II
LAUNDRY WASHERS	II	III
LUMBER INDUSTRY		
Barkers		
Spindle Feed	II	II
Main Drive	III	III
Conveyors		
Burner	II	II
Main or Heavy Duty	II	II
Main Log	III	III
Re-saw, Merry-Go-Round	II	II
Slab	III	III
Transfer	II	II
Chains		
Floor	II	II
Green	II	III

★ Consult DODGE for more information on class number

FEATURES/BENEFITS
PAGE G1-3NOMENCLATURE
PAGE G1-8SELECTION/DIMENSIONS
PAGE G1-36RELATED PRODUCTS
PAGE G1-123



TORQUE-ARM II Shaft Mount Speed Reducers

Table 1: APPLICATION CLASSIFICATION AND CLASS NUMBERS

Application	Class Numbers		Application	Class Numbers	
	3 to 10 Hrs per Day	Over 10 Hrs per Day		3 to 10 Hrs per Day	Over 10 Hrs per Day
LUMBER INDUSTRY (cont)			MIXERS, CEMENT	II	II
Cut-Off Saws			PAPER MILLS		
Chain	II	III	Agitator (Mixer)	II	II
Drag	II	III	Agitator for Pure Liquors	II	II
Debarking Drums	III	III	Barking Drums	III	III
Feeds			Barkers-Mechanical	III	III
Edger	II	II	Beater	II	II
Gang	III	III	Breaker Stack	II	II
Trimmer	II	II	Chipper	III	III
Log Deck	III	III	Chip Feeder	II	II
Log Hauls-Incline-Well Type	III	III	Coating Rolls	II	II
Log Tuning Devices	III	III	Conveyors		
Planer Feed	II	II	Chip, Bark, Chemical	II	II
Planer Tilting Hoists	II	II	Log (including Slab)	III	III
Rolls-Live-off brg.-Roll Cases	III	III	Couch Rolls	II	II
Sorting Table	II	II	Cutter	III	III
Triple Hoist	II	II	Cylinder Molds	II	II
Transfers			Embossor	II	II
Chain	II	III	Extruder	II	II
Craneway	II	III	Fourdrinier Rolls (includes Lump		
Tray Drives	II	II	breaker, dandy roll, wire		
Veneer Lathe Drives	II	II	turning, and return rolls)	II	II
			Jordan	II	II
METAL MILLS			Kiln Drive	II	II
Draw bench Carriage and Main Drive	II	II	Mt. Hope Roll	II	II
Runout Table			Paper Rolls	II	II
Non-Reversing			Platter	II	II
Group Drives	II	II	Presses-Felt & Suction	II	II
Individual Drives	III	III	Pulper	III	III
Reversing	III	III	Pumps-Vacuum	II	II
Slab Pushers	II	II	Reel (Surface Type)	II	II
Shears	III	III	Screens		
Wire Drawing	II	II	Chip	II	II
Wire Winding Machine	II	II	Rotary	II	II
			Vibrating	III	III
METAL STRIP PROCESSING MACHINERY	II	II	Size Press	II	II
Bridles	I	II	Thickener (AC Motor)	II	II
Coilers & Uncoliers	II	II	(DC Motor)	II	II
Edge Trimmers	II	II	Washer (AC Motor)	II	II
Flatteners	I	I	(DC Motor)	II	II
Loopers (Accumulators)	II	II	Wind and Unwind Stand	I	I
Pinch Rolls	II	II	Winders (Surface Type)	II	II
Scrap Choppers	III	III			
Shears	II	II	PLASTICS INDUSTRY-SECONDARY PROCESSING		
Slitters			Blow Molders	II	II
MILLS, ROTARY TYPE			Coating	II	II
Ball & Rod			Film	II	II
Spur Ring Gear	III	III	Pipe	II	II
Helical Ring Gear	II	II	Pre-Plasticizers	II	II
Direct Connected	III	III	Rods	II	II
Cement Kilns	II	II	Sheet	II	II
Dryers & Coolers	II	II	Tubing	II	II

FEATURES/BENEFITS PAGE G1-3	NOMENCLATURE PAGE G1-8	SELECTION/DIMENSIONS PAGE G1-36	RELATED PRODUCTS PAGE G1-123
--------------------------------	---------------------------	------------------------------------	---------------------------------

SELECTION



TORQUE-ARM II Shaft Mount Speed Reducers

Table 1: APPLICATION CLASSIFICATION AND CLASS NUMBERS

Application	Class Numbers	
	3 to 10 Hrs per Day	Over 10 Hrs per Day
PULLERS-BARGE HAUL PUMPS	II	II
Centrifugal	I	II
Proportioning	II	II
Reciprocating		
Single Acting, 3 or more cylinders	II	II
Double Acting, 2 or more cylinders	II	II
Rotary		
Gear Type	I	II
Lobe	I	II
Vane	I	II
RUBBER AND PLASTICS INDUSTRY		
Intensive Internal Mixers		
Batch Mixers	III	III
Continuous Mixers	II	II
Mixing Mill		
2 smooth rolls	II	II
1 or 2 corrugated rolls	III	III
Batch Drop Mill - 2 smooth rolls	II	II
Cracker Warmer - 2 roll, 1 corrugated roll	III	III
Cracker-2 corrugated rolls	II	II
Holding, Feed & Blend Mill-2 rolls	II	II
Refiner-2 rolls	II	II
Calenders		
SAND MULLER	II	II
SEWAGE DISPOSAL EQUIPMENT		
Bar Screens	II	II
Chemical Feeders	II	II
Dewatering Screens	II	II
Scum Breakers	II	II
Slow or Rapid Mixers	II	II
Sludge Collectors	II	II
Thickener	II	II
Vacuum Filters	II	II
SCREENS		
Air Washing	I	II
Rotary-Stone or Gravel	II	II
Traveling Water Intake	I	I
SCREW CONVEYORS		
Uniformly Loaded or Fed	I	II
Heavy Duty	II	II
SUGAR INDUSTRY		
Beet Slicer	III	III
Cane knives	II	II
Crushers	II	II
Mills (low speed end)	III	III

Application	Class Numbers	
	3 to 10 Hrs per Day	Over 10 Hrs per Day
TEXTILE INDUSTRY		
Batchers	II	II
Calenders	II	II
Cards	II	II
Dry Cans	II	II
Dyeing Machinery	II	II
Looms	II	II
Mangles	II	II
Nappers	II	II
Pads	II	II
Stashers	II	II
Soapers	II	II
Spinners	II	II
Tenter Frames	II	II
Washers	II	II
Winders	II	II

SELECTION



TORQUE-ARM II Shaft Mount Speed Reducers CLASS I SELECTIONS * (SF = 1.0)

Motor HP	Output RPM	Reducer Selection	Min. Sheave Dia. P.D.	Cooling Method	Motor HP	Output RPM	Reducer Selection	Min. Sheave Dia. P.D.	Cooling Method	Motor HP	Output RPM	Reducer Selection	Min. Sheave Dia. P.D.	Cooling Method									
1/4	4-50	TA0107L31	4.0	---	1/2 (cont)	81-89	TA0107L15	4.0	---	1 (cont)	90-120	TA0107L15	4.0	---									
		TA0107L25	4.0	---			TA0107L09	5.3	---			TA0107L09	5.2	---	TA0107L05	9.2	---						
		TA0107L15	4.0	---			TA0107L15	4.0	---			TA0107L09	5.2	---	TA0107L05	9.2	---						
	51-80	TA0107L25	4.0	---			TA0107L09	5.0	---			121-200	TA0107L09	5.0	---	201-400	TA0107L05	6.9	---				
		TA0107L15	4.0	---			TA0107L05	8.3	---				TA0107L05	6.9	---								
	81-89	TA0107L15	4.0	---			3/4	4-6	TA2115H33			3.7	---	1-1/2	4-5	TA4207H40	5.0	---					
		TA0107L09	5.3	---	TA2115H25	3.3			---	TA4207H25	5.5	---											
	90-120	TA0107L15	4.0	---	TA2115H15	3.3			---	6-7	TA3203H32	4.6	---			6-7	TA3203H25	4.6	---				
		TA0107L09	5.2	---	TA1107H31	5.0			---		TA3203H15	4.6	---										
	121-200	TA0107L09	5.0	---	7-11	TA1107H25			6.4	---	8-12	TA2115H33	3.7			---	8-12	TA2115H25	3.3	---			
TA0107L05		8.3	---	TA1107H15		5.5			---	TA2115H15		3.3	---										
201-400	TA0107L05	6.9	---	1/3	12-50	TA0107L31			4.0	---	1-1/2	13-23	TA1107H31			4.9	---						
4	TA1107H25	6.4	---			51-80			TA0107L25	4.0			---			24-50	TA0107L31	4.0	---	13-23	TA1107H25	6.2	---
	TA1107H15	5.5	---						TA0107L15	4.0			---				TA0107L25	4.0	---		TA1107H15	5.5	---
5-50	TA0107L31	4.0	---			81-89			TA0107L25	4.0			---			51-80	TA0107L15	4.0	---	51-80	TA0107L15	4.0	---
	TA0107L25	4.0	---				TA0107L09	5.3	---	TA0107L15			4.0	---									
51-80	TA0107L25	4.0	---			90-120	TA0107L15	4.0	---	81-89			TA0107L15	4.0	---	81-89	TA0107L15	4.0	---				
	TA0107L15	4.0	---				TA0107L09	5.3	---				TA0107L09	5.3	---								
81-89	TA0107L15	4.0	---			121-200	TA0107L09	5.0	---	90-120			TA0107L15	4.0	---	90-120	TA0107L15	4.0	---				
	TA0107L09	5.3	---				TA0107L05	8.3	---				TA0107L09	5.2	---		TA0107L05	9.2	---				
90-120	TA0107L15	4.0	---			201-400	TA0107L05	6.9	---	121-200			TA0107L05	8.3	---	121-200	TA0107L05	8.3	---				
	TA0107L09	5.2	---	TA3203H32	4.6		---	TA0107L05	6.9		---												
121-200	TA0107L09	5.0	---	1/2	4-5	TA3203H25	4.6	---	2	4	TA5215H40	6.8	---										
	TA0107L05	8.3	---			6-8	TA2115H33	3.7			---	5-6	TA5215H25	6.1	---								
201-400	TA0107L05	6.9	---				TA2115H15	3.3			---		TA5215H15	7.1	---								
4	TA2115H33	3.7	---			9-15	TA1107H31	5.0			---	7-10	TA4207H40	5.0	---								
	TA2115H25	3.3	---				TA1107H25	6.4			---		TA4207H25	5.5	---								
5-7	TA1107H31	5.0	---			16-50	TA1107H15	5.5			---	7-10	TA4207H15	8.1	---								
	TA1107H25	6.4	---				TA0107L31	4.0			---		TA3203H32	4.6	---								
8-50	TA1107H15	5.5	---			51-80	TA0107L25	4.0			---	11-16	TA3203H25	4.6	---								
	TA0107L31	4.0	---				TA0107L15	4.0			---		TA3203H15	4.6	---								
TA0107L25	4.0	---	81-89			TA0107L15	4.0	---			11-16	TA2115H33	3.7	---									
	TA0107L15	4.0		---	TA0107L09	5.3	---	TA2115H25	3.3	---													
51-80	TA0107L25	4.0	---																				

* See Page G1-132 for lubrication for 15 RPM and slower

FEATURES/BENEFITS PAGE G1-3	NOMENCLATURE PAGE G1-8	SELECTION/DIMENSIONS PAGE G1-36	RELATED PRODUCTS PAGE G1-123
--------------------------------	---------------------------	------------------------------------	---------------------------------



SELECTION

TORQUE-ARM II Shaft Mount Speed Reducers

CLASS I SELECTIONS (cont) * (SF = 1.0)

Motor HP	Output RPM	Reducer Selection	Min. Sheave Dia. P.D.	Cooling Method	Motor HP	Output RPM	Reducer Selection	Min. Sheave Dia. P.D.	Cooling Method	Motor HP	Output RPM	Reducer Selection	Min. Sheave Dia. P.D.	Cooling Method	
2 (cont)	17	TA1107H31	4.8	---	3 (cont)	121-200	TA0107L09	5.0	---	7-1/2 (cont)	7-9	TA6307H40	6.3	---	
		TA2115H25	3.3	---			TA0107L05	8.3	---			TA6307H25	6.3	---	
		TA1107H15	5.4	---		201-400	TA0107L05	6.9	---			TA6307H15	6.4	---	
	18-32	TA1107H31	4.8	---		4	TA7315H40	6.2	---		10-15	TA5215H40	6.8	---	
		TA1107H25	5.9	---				TA7315H25	6.2			---	TA5215H25	6.1	---
		TA1107H15	5.3	---				TA7315H15	6.2			---	TA5215H15	7.1	---
	33-50	TA0107L31	4.0	---		5-6	TA6307H40	6.3	---		16-25	TA4207H40	4.8	---	
		TA0107L25	4.0	---				TA6307H25	6.3			---	TA4207H25	5.4	---
		TA0107L15	4.0	---				TA6307H15	6.4			---	TA4207H15	7.9	---
	51-80	TA0107L25	4.0	---		7-10	TA5215H40	6.8	---		26-39	TA3203H32	4.2	---	
TA0107L15		4.0	---	TA5215H25	6.1			---	TA3203H25	4.4		---			
81-89	TA0107L15	4.0	---	11-16	TA4207H40	5.0	---	40-50	TA2115H33	3.2	---				
	TA0107L09	5.3	---			TA4207H25	5.5		---	TA2115H25	3.1	---			
90-120	TA0107L15	4.0	---	17-25	TA3203H32	4.4	---	51-72	TA2115H25	3.1	---				
	TA0107L09	5.2	---			TA3203H25	4.5		---	TA2115H15	3.6	---			
121-200	TA0107L05	5.0	---	26	TA3203H15	4.5	---	73-80	TA1107H25	5.2	---				
	TA0107L05	8.3	---			TA3203H32	4.2		---	TA1107H15	4.7	---			
3	4-6	TA5215H40	6.8	---	5	TA2115H25	3.2	---	81-89	TA1107H15	4.6	---			
		TA5215H25	6.1	---			TA2115H15	3.1		---	TA1107H09	7.7	---		
		TA5215H15	7.1	---			27-46	TA2115H33		3.6	---	90-120	TA1107H15	4.6	---
	TA4207H40	5.0	---	TA2115H25		3.2		---	TA1107H09	7.5	---				
	TA4207H25	5.5	---	TA2115H15		3.1		---	TA1107H05	12.5	---				
	7-10	TA4207H15	8.1	---		47-50	TA1107H31	4.4	---	121-145	TA1107H09	7.1	---		
		TA3203H32	4.6	---			TA1107H25	5.4	---		TA1107H05	11.2	---		
	11-15	TA3203H25	4.6	---		51-80	TA1107H15	4.9	---	146-163	TA0107L09	4.8	---		
		TA3203H15	4.6	---			TA1107H25	5.4	---		TA1107H05	10.3	---		
		TA2115H33	3.7	---			TA1107H15	4.9	---		164-200	TA0107L09	4.7	---	
16-26	TA2115H25	3.3	---	81-89	TA1107H15	4.6	---	TA0107L05	7.4	---					
	TA2115H15	3.2	---		TA1107H09	7.7	---	201-400	TA0107L05	6.9	---				
27-50	TA1107H31	4.6	---	90-120	TA0107L15	4.0	---	4	TA9415H40	8.0	---				
	TA1107H25	5.7	---		TA0107L09	5.2	---		TA9415H25	8.0	---				
	TA1107H15	5.2	---		TA0107L05	9.2	---		TA9415H15	10.2	---				
51-80	TA0107L25	4.0	---	121-200	TA0107L09	5.0	---	5	TA8407H40	6.2	---				
	TA0107L15	4.0	---		TA0107L05	8.3	---		TA8407H25	6.2	---				
81-89	TA0107L15	4.0	---	201-400	TA0107L05	6.9	---		TA8407H15	6.2	---				
	TA0107L09	5.3	---		7-1/2	4	TA8407H40	6.2	---	TA7315H40	6.2	---			
90-120	TA0107L15	4.0	---	TA8407H25			6.2	---	TA7315H25	6.2	---				
	TA0107L09	5.2	---	TA8407H15			6.2	---	TA7315H15	6.2	---				
		TA0107L05	9.2	---	5-6	TA7315H40	6.2	---	9-12	TA6307H40	6.3	---			
						TA7315H25	6.2	---		TA6307H25	6.3	---			
						TA7315H15	6.2	---		TA6307H15	6.4	---			

* See Page G1-132 for lubrication for 15 RPM and slower

FEATURES/BENEFITS PAGE G1-3	NOMENCLATURE PAGE G1-8	SELECTION/DIMENSIONS PAGE G1-36	RELATED PRODUCTS PAGE G1-123
--------------------------------	---------------------------	------------------------------------	---------------------------------

SELECTION



TORQUE-ARM II Shaft Mount Speed Reducers

CLASS I SELECTIONS (cont) * (SF = 1.0)

Motor HP	Output RPM	Reducer Selection	Min. Sheave Dia. P.D.	Cooling Method	Motor HP	Output RPM	Reducer Selection	Min. Sheave Dia. P.D.	Cooling Method	Motor HP	Output RPM	Reducer Selection	Min. Sheave Dia. P.D.	Cooling Method
10 (cont)	13-20	TA5215H40	6.7	---	15 (cont)	9-13	TA7315H40	6.2	---	20 (cont)	12-18	TA7315H40	6.2	---
		TA5215H25	6.0	---			TA7315H25	6.2	---			TA7315H25	6.2	---
		TA5215H15	7.0	---			TA7315H15	6.2	---			TA7315H15	6.2	---
	21-32	TA4207H40	4.7	---		14-18	TA6307H40	6.3	---		19-25	TA6307H40	6.3	---
		TA4207H25	5.2	---			TA6307H25	6.3	---			TA6307H25	6.3	---
		TA4207H15	7.7	---			TA6307H15	6.3	---			TA6307H15	6.3	---
	34-50	TA3203H32	4.1	---		19-32	TA5215H40	6.5	---		26-45	TA5215H40	6.4	---
		TA3203H25	4.3	---			TA5215H25	5.9	---			TA5215H25	5.7	---
		TA3203H15	4.3	---			TA5215H15	6.8	---			TA5215H15	6.7	---
	51-55	TA3203H25	4.2	---		33-50	TA4207H40	4.5	---		46-50	TA4207H40	4.3	---
		TA3203H15	4.2	---			TA4207H25	5.0	---			TA4207H25	4.7	---
	56-80	TA2115H25	3.1	---			TA4207H15	7.3	---			TA4207H15	7.0	---
		TA2115H15	3.6	---		51-53	TA4207H25	4.7	---		51-75	TA4207H25	4.7	---
	81-89	TA2115H15	3.7	---			TA4207H15	6.8	---			TA4207H15	6.8	---
		90-100	TA2115H09	6.1		---	54-80	TA3203H25	4.1		---	76-80	TA3203H25	4.4
	TA2115H15		3.7	---		TA3203H15		4.2	---		TA3203H15		4.1	---
	TA2115H09		6.2	---		TA3203H15		4.0	---		TA3203H15		4.0	---
	101	TA2115H05	6.5	---		81-89	TA3203H09	5.2	---		81-89	TA3203H15	4.0	---
TA1107H15		4.5	---	TA3203H15	4.0		---	TA3203H09	5.2	---				
TA2115H09		6.2	---	TA3203H09	5.3		---	TA3203H15	4.0	---				
102-118	TA2115H05	6.5	---	90-92	TA3203H05	11.0	---	90-103	TA3203H09	5.4	---			
	TA1107H15	4.5	---		TA2115H15	3.7	---		TA4207H05	9.9	---			
	TA1107H09	7.4	---		TA2115H09	6.2	---		TA4207H15	6.1	---			
119-120	TA2115H05	6.6	---	93-120	TA3203H05	10.4	---	104-105	TA3203H09	5.4	---			
	TA1107H15	4.4	---		TA2115H05	6.4	---		TA4207H05	9.6	---			
	TA1107H09	7.1	---		TA3203H05	10.4	---		TA4207H15	6.1	---			
121-200	TA1107H05	11.2	---	121-143	TA2115H09	6.1	---	106-120	TA3203H09	5.6	---			
	TA1107H05	11.2	---		TA3203H05	7.7	---		TA3203H05	8.6	---			
	TA1107H09	7.1	---		TA2115H05	6.0	---		TA4207H15	6.1	---			
201-276	TA1107H05	11.2	---	144-200	TA2115H09	6.5	---	121-141	TA3203H09	5.7	---			
	TA1107H05	11.2	---		TA2115H05	6.4	---		TA3203H05	7.7	---			
	TA1107H05	11.2	---		TA2115H05	6.0	---		TA2115H09	6.5	---			
15	277-400	TA0107L05	5.8	---	4	TA12608H40	17.2	---	142-200	TA2115H09	6.5	---		
		TA10507H40	8.5	---		TA12608H25	9.5	---		TA3203H05	7.2	---		
		TA10507H25	8.5	---		TA12608H15	13.7	---		TA3203H05	7.0	---		
	4	TA10507H15	10.8	---	5-6	TA10507H40	8.5	---	201-238	TA3203H05	7.0	---		
		TA9415H40	8.0	---		TA10507H25	8.5	---		TA2115H05	5.7	---		
		TA9415H25	8.0	---		TA10507H15	10.8	---		4	TDT1425 †	15.0	---	
	5-6	TA9415H15	10.2	---	7-8	TA9415H40	8.0	---	5	TA12608H40	17.2	---		
		TA8407H40	6.2	---		TA9415H25	8.0	---		TA12608H25	9.5	---		
		TA8407H25	6.2	---		TA9415H15	10.2	---		TA12608H15	13.7	---		
	7-8	TA8407H15	6.2	---	9-11	TA8407H40	6.2	---	6-7	TA10507H40	8.5	---		
		TA8407H25	6.2	---		TA8407H25	6.2	---		TA10507H25	8.5	---		
		TA8407H15	6.2	---		TA8407H15	6.2	---		TA10507H15	10.8	---		

* See Page G1-132 for lubrication for 15 RPM and slower

FEATURES/BENEFITS PAGE G1-3	NOMENCLATURE PAGE G1-8	SELECTION/DIMENSIONS PAGE G1-36	RELATED PRODUCTS PAGE G1-123
--------------------------------	---------------------------	------------------------------------	---------------------------------



SELECTION

TORQUE-ARM II Shaft Mount Speed Reducers

CLASS I SELECTIONS (cont) * (SF = 1.0)

Motor HP	Output RPM	Reducer Selection	Min. Sheave Dia. P.D.	Cooling Method	Motor HP	Output RPM	Reducer Selection	Min. Sheave Dia. P.D.	Cooling Method	Motor HP	Output RPM	Reducer Selection	Min. Sheave Dia. P.D.	Cooling Method						
25 (cont)	8-10	TA9415H40	8.0	---	30 (cont)	4-5	TDT1425 †	15.0	---	40	4	TDT1530 †	15.0	---						
		TA9415H25	8.0	---		6	TA12608H40	17.2	---		5-6	TDT1425 †	15.0	---						
		TA9415H15	10.2	---			TA12608H25	9.5	---		7	TA12608H40	17.2	---						
	11-15	TA8407H40	6.2	---		TA12608H15	13.7	---	TDT1425 †			15.0	---							
		TA8407H25	6.2	---		7-9	TA10507H40	8.5	---		8	TA12608H40	17.2	---						
	TA8407H15	6.2	---	TA10507H25			8.5	---	TA12608H25			9.5	---							
	16-23	TA7315H40	6.2	---		TA10507H15	10.8	---	9-12		TA12608H15	13.7	---							
		TA7315H25	6.2	---		10-12	TA9415H40	8.0			---	TA10507H40	8.5	---						
	24-32	TA7315H15	6.2	---			TA9415H25	8.0	---		9-12	TA10507H25	8.5	---						
		TA6307H40	6.3	---		TA9415H15	10.3	---	TA10507H15			10.8	---							
		TA6307H25	6.3	---		13-18	TA8407H40	6.2	---		13-17	TA9415H40	8.0	---						
	TA6307H15	6.3	---	TA8407H25			6.2	---	TA9415H25			8.0	---							
	33-50	TA5215H40	6.3	---		TA8407H15	6.2	---	18-25		TA9415H15	10.5	---							
		TA5215H25	5.6	---		19-28	TA7315H40	6.2			---	TA8407H40	6.2	---						
		TA5215H15	6.5	---			TA7315H25	6.2	---		TA8407H25	6.2	---							
	51-58	TA5215H25	5.4	---		TA7315H15	6.2	---	18-25		TA8407H15	6.2	---							
		TA5215H15	6.3	---		29-30	TA6307H40	6.3			---	26-38	TA7315H40	6.2	---					
	59-80	TA4207H25	4.6	---			TA6307H25	6.3	---		TA7315H25		6.2	---						
		TA4207H15	6.7	---		TA6307H15	6.3	---	TA7315H15		6.2	---								
	81-89	TA4207H15	6.4	---		31-39	TA6307H40	6.2	---		39-50	TA6307H40	6.2	---						
TA4207H09		10.1	---	TA6307H25	6.2		---	TA6307H25	6.2	---										
90-110	TA4207H15	6.3	---	TA6307H15	6.3	---	39-50	TA6307H15	6.2	---										
	TA4207H09	9.9	---	40-50	TA5215H40	6.2		---	51-54	TA6307H25	6.2	---								
	TA5215H05	13.9	---		TA5215H25	5.5	---	55-80	TA6307H15	6.2	---									
111-120	TA4207H15	6.0	---	TA5215H15	6.4	---	55-80	TA5215H25	5.4	---										
	TA4207H09	9.4	---	51-72	TA5215H25	5.4		---	TA5215H15	6.3	---									
	TA4207H05	9.5	---		TA5215H15	6.3	---	81-89	TA5215H15	6.0	---									
121-163	TA4207H09	9.3	---	73-80	TA4207H25	4.4	---		TA5215H09	9.1	---									
	TA4207H05	9.3	---		TA4207H15	6.5	---	90-102	TA5215H15	5.7	---									
164-200	TA4207H09	8.5	---	81-89	TA4207H15	6.4	---		TA5215H09	8.9	---									
	TA3203H05	7.0	---		TA4207H09	10.1	---	TA5215H05	13.9	---										
201-400	TA3203H05	7.0	---	90-120	TA4207H15	6.3	---	103-107	TA4207H15	6.1	---									
30	4-5	TDT1425 †	15.0		---	TA4207H09	9.9		---	TA5215H09	8.6	---								
	6	TA12608H40	17.2		---	TA5215H05	13.9	---	TA5215H05	12.9	---									
TA12608H25		9.5	---		121-132	TA4207H09	9.3	---	TA4207H15	6.0	---									
TA12608H15		13.7	---			TA5215H05	11.8	---	108-120	TA4207H09	9.5	---								
* See Page G1-132 for lubrication for 15 RPM and slower † See DODGE Gear Engineering Catalog DMR-1205-2 for information on TDT1425 and TDT1530 Reducers					201-215	TA4207H05	9.3	---	121-182	TA4207H09	9.3	---								
					216-400	TA3203H05	7.0	---		TA5215H05	11.8	---	183-185	TA4207H09	8.1	---				
					* See Page G1-132 for lubrication for 15 RPM and slower † See DODGE Gear Engineering Catalog DMR-1205-2 for information on TDT1425 and TDT1530 Reducers					201-215	TA4207H05	9.3	---	183-185	TA4207H09	8.1	---			
										216-400	TA3203H05	7.0	---		TA4207H05	9.1	---	TA4207H05	9.1	---

FEATURES/BENEFITS PAGE G1-3	NOMENCLATURE PAGE G1-8	SELECTION/DIMENSIONS PAGE G1-36	RELATED PRODUCTS PAGE G1-123
--------------------------------	---------------------------	------------------------------------	---------------------------------

SELECTION



TORQUE-ARM II Shaft Mount Speed Reducers CLASS I SELECTIONS (cont) * (SF = 1.0)

Motor HP	Output RPM	Reducer Selection	Min. Sheave Dia. P.D.	Cooling Method	Motor HP	Output RPM	Reducer Selection	Min. Sheave Dia. P.D.	Cooling Method	Motor HP	Output RPM	Reducer Selection	Min. Sheave Dia. P.D.	Cooling Method		
40 (cont)	186-200	TA4207H09	8.0	---	50 (cont)	94-120	TA5215H15	5.6	---	60 (cont)	94-115	TA5215H15	5.6	---		
		TA4207H05	9.2	---			TA5215H09	8.8	---			TA5215H09	8.8	---		
	201-400	TA4207H05	9.8	---			TA5215H05	13.6	---			TA5215H15	5.1	Fan		
50	4-5	TDT1530 †	15.0	---	50 (cont)	121-144	TA5215H09	8.3	---	60 (cont)	116-120	TA5215H15	5.1	Fan		
	6-8	TDT1425 †	15.0	---			TA5215H05	11.8	---			TA5215H09	8.4	---		
	9-10	TA12608H40	17.2	---			TA4207H09	8.9	---			121-131	TA5215H09	8.3	---	
		TA12608H25	9.5	---				TA5215H05	11.2				---	TA6307H05	14.5	---
		TA12608H15	13.7	---				TA5215H05	11.2				---	TA5215H09	7.9	---
	11-15	TA10507H40	8.5	---			201-242	TA5215H05	9.9			---	132-200	TA5215H05	11.4	---
		TA10507H25	8.5	---	TA4207H05	9.7		---	TA5215H05	11.4	---					
		TA10507H15	10.8	---	60	4-6	TDT1530 †	15.0	---	75	201-400	TA5215H05	9.9	---		
		TA9415H40	8.0	Fan			7-10	TDT1425 †	15.0			---	5-8	TDT1530 †	15.0	---
	16-17	TA9415H25	8.0	---		11-13		TA12608H40	17.2		---	9-13	TDT1425 †	15.0	---	
		TA9415H15	10.5	---			TA12608H25	9.5	---		14-16	TA12608H40	17.1	---		
		TA9415H15	10.5	---			TA12608H15	13.9	---			TA12608H25	9.5	---		
	18-21	TA9415H40	8.0	---		14-18	TA10507H40	8.5	---			17-23	TA12608H15	14.2	---	
		TA9415H25	8.0	---			TA10507H25	8.5	---		TA10507H40		8.5	---		
		TA9415H15	10.7	---		TA10507H15	10.8	---	TA10507H25		8.5	---				
	22-27	TA8407H40	6.2	Fan		19	TA9415H40	8.0	Fan		24-33	TA10507H15	10.8	---		
		TA8407H25	6.2	---			TA9415H25	8.0	Fan			TA9415H40	8.0	Fan		
		TA8407H15	6.2	---			TA9415H15	10.7	---			TA9415H25	8.0	Fan		
	28-32	TA8407H40	6.2	---		20-26	TA9415H40	8.0	Fan		34-37	TA9415H15	10.8	---		
		TA8407H25	6.2	---			TA9415H25	8.0	---			TA8407H40	6.2	Fan		
		TA8407H15	6.2	---			TA9415H15	10.8	---			TA8407H25	6.2	Fan		
	33-49	TA7315H40	6.2	---		27-30	TA8407H40	6.2	Fan		38-49	TA8407H15	6.2	Fan		
		TA7315H25	6.2	---			TA8407H25	6.2	Fan			TA8407H40	6.2	Fan		
		TA7315H15	6.2	---			TA8407H15	6.2	---			TA8407H25	6.2	Fan		
	50	TA6307H40	6.2	Fan		31-39	TA8407H40	6.2	Fan		50	TA8407H15	6.2	---		
		TA6307H25	6.2	---			TA8407H25	6.2	---			TA7315H40	6.2	Fan		
		TA6307H15	6.2	---			TA8407H15	6.2	---			TA7315H25	6.2	Fan		
51-69	TA6307H25	6.2	---	40-50		TA7315H40	6.2	Fan	51-77		TA7315H15	6.2	---			
	TA6307H15	6.2	---			TA7315H25	6.2	---			TA7315H25	6.2	Fan			
70-80	TA5215H25	5.3	Fan	51-60		TA7315H15	6.2	---	78-80		TA7315H15	6.2	---			
	TA5215H15	6.1	---			TA7315H25	6.2	---			TA6307H25	6.2	Fan			
81-89	TA5215H15	6.0	---	61-80		TA7315H15	6.2	---	81-89		TA6307H15	6.2	Fan			
	TA5215H09	9.1	---			TA6307H25	6.2	---			TA6307H15	6.3	Fan			
90-93	TA5215H15	5.7	---	81-88		TA6307H15	6.2	---	90-101		TA6307H09	9.9	Fan			
	TA5215H09	8.9	---		TA6307H15	6.3	---	TA6307H15		6.5	Fan					
	TA6307H05	15.1	---		TA6307H09	9.9	---	TA6307H09		10.3	Fan					
* See Page G1-132 for lubrication for 15 RPM and slower † See DODGE Gear Engineering Catalog DMR-1205-2 for information on TDT1425 and TDT1530 Reducers					89	TA5215H15	5.7	Fan	102-120	TA6307H15	6.7	Fan				
						TA6307H09	9.9	---		TA6307H09	10.8	Fan				
						TA6307H05	15.1	---		TA6307H05	15.1	---				

FEATURES/BENEFITS PAGE G1-3	NOMENCLATURE PAGE G1-8	SELECTION/DIMENSIONS PAGE G1-36	RELATED PRODUCTS PAGE G1-123
--------------------------------	---------------------------	------------------------------------	---------------------------------

SELECTION



TORQUE-ARM II Shaft Mount Speed Reducers

CLASS I SELECTIONS (cont) * (SF = 1.0)

Motor HP	Output RPM	Reducer Selection	Min. Sheave Dia. P.D.	Cooling Method	Motor HP	Output RPM	Reducer Selection	Min. Sheave Dia. P.D.	Cooling Method	Motor HP	Output RPM	Reducer Selection	Min. Sheave Dia. P.D.	Cooling Method
75 (cont)	121-129	TA6307H09 TA6307H05	10.8 14.5	Fan ---	100 (cont)	111	TA6307H15 TA6307H09	6.6 10.5	Fan Fan	150	9-17	TD1530 †	15.0	---
	130-196	TA5215H09 TA6307H05	7.9 14.4	---		112-120	TA6307H15 TA6307H09	6.7 10.8	Fan Fan		27-34	TA12608H40 TA12608H25 TA12608H15	17.1 9.5 15.1	P&C Fan Fan
		197-200	TA5215H09 TA6307H05	5.9 13.9			Fan ---	121-157	TA6307H09 TA7315H05			10.9 12.8	Fan ---	35-36
	201-208		TA6307H05	13.8		---	158-200		TA6307H09 TA6307H05		10.9 14.2	Fan ---	37-49	
	209-400	TA5215H05	9.7	---		201-400		TA6307H05	13.8		---	50		TA9415H40 TA9415H25 TA9415H15
	100	6-11	TDT1530 †	15.0		---	8-14	TDT1530 †	15.0		---		51-72	TA9415H40 TA9415H25 TA9415H15
12-17		TDT1425 †	15.0	---	15-21	TDT1425 †		15.0	---	73-80	TA8407H25 TA8407H15	6.2 7.5		P&C Fan
18-19		TA12608H40 TA12608H25 TA12608H15	17.1 9.5 14.4	Fan ---		22-26	TA12608H40 TA12608H25 TA12608H15	17.1 9.5 14.8	Fan Fan Fan		81-112	TA8407H25 TA8407H15	6.2 8.6	P&C Fan
		20-22	TA12608H40 TA12608H25 TA12608H15	17.1 9.5 14.6	---		27-28	TA12608H40 TA12608H25 TA12608H15	17.1 9.5 14.9	Fan Fan ---		113	TA7315H15 TA7315H09	6.2 8.5
23-26			TA10507H40 TA10507H25 TA10507H15	8.5 8.5 10.7	Fan Fan ---	29		TA10507H40 TA12608H25 TA12608H15	8.5 9.5 14.9	Fan Fan ---	114-120		TA7315H15 TA7315H09	6.2 8.5
		27-31	TA10507H40 TA10507H25 TA10507H15	8.5 8.5 10.6	Fan ---		30-40	TA10507H40 TA10507H25 TA10507H15	8.5 8.5 10.8	Fan Fan Fan		121-200	TA7315H09 TA7315H05	8.6 11.5
32-46			TA9415H40 TA9415H25 TA9415H15	8.0 8.0 10.8	Fan Fan Fan	41-50		TA9415H40 TA9415H25 TA9415H15	8.0 8.0 10.8	P&C P&C Fan	213-400		TDT1530 †	15.0
		47-50	TA8407H40 TA8407H25 TA8407H15	6.2 6.2 6.2	Fan Fan Fan		51-59	TA9415H25 TA9415H15	8.0 10.8	P&C Fan		24-35	TDT1425 †	15.0
51-68			TA8407H25 TA8407H15	6.2 7.0	Fan Fan	60-80		TA8407H25 TA8407H15	6.2 7.5	P&C Fan	36-47		TA12608H40 TA12608H25 TA12608H15	17.1 9.5 15.6
		69-80	TA7315H25 TA7315H15	6.2 6.2	Fan Fan		81-88	TA8407H15	7.8	Fan		48-50	TA10507H40 TA12608H25 TA12608H15	8.5 9.5 15.7
81-110			TA7315H15 TA7315H09	6.2 8.5	Fan Fan	89-90		TA7315H15	6.2	Fan	51		TA12608H25 TA12608H15	9.6 15.7
		* See Page G1-132 for lubrication for 15 RPM and slower † See DODGE Gear Engineering Catalog DMR-1205-2 for information on TDT1425 and TDT1530 Reducers P&C (Pump & Coolers) - Use the DODGE Speed Reducer Auxiliary cooling package, part number 014148					91-120	TA7315H15 TA7315H09	6.2 8.5	Fan Fan		52-67	TA10507H25 TA10507H15	8.8 12.4
121-149								TA7315H09	8.6	Fan	68		TA9415H25 TA10507H15	8.0 12.5
							150-160	TA6307H09	10.9	Fan		69-80	TA9415H25 TA9415H15	8.0 10.7
161-200								TA6307H09 TA7315H05	10.8 11.9	Fan ---	81-100		TA9415H15	10.5
							201-225	TA7315H05	11.7	---		101-120	TA8407H15	8.7
226-368	TA6307H05						12.8	---						
369-400	TA6307H05						10.9	Fan						

FEATURES/BENEFITS PAGE G1-3	NOMENCLATURE PAGE G1-8	SELECTION/DIMENSIONS PAGE G1-36	RELATED PRODUCTS PAGE G1-123
--------------------------------	---------------------------	------------------------------------	---------------------------------

SELECTION



TORQUE-ARM II Shaft Mount Speed Reducers CLASS I SELECTIONS (cont) * (SF = 1.0)

Motor HP	Output RPM	Reducer Selection	Min. Sheave Dia. P.D.	Cooling Method	Motor HP	Output RPM	Reducer Selection	Min. Sheave Dia. P.D.	Cooling Method
200 (cont)	172-200	TA7315H09	8.4	P&C	400 (cont)	71-80	TA12608H25 TA12608H15	10.7 16.1	P&C P&C
	331-400	TA7315H05	10.8	Fan		81-120	TA12608H15	15.6	P&C
250	16-30	TDT1530 †	15.0	---	450	30-31	TDT1530 †	15.0	P&C
	31-43	TDT1425 †	15.0	Fan		32-57	TDT1530 †	15.0	Fan
	44-50	TA12608H40	17.1	P&C		59-75	TDT1425 †	15.0	P&C
		TA12608H25 TA12608H15	9.5 15.7	P&C P&C		84-120	TA12608H15	15.5	P&C
	51-67	TA12608H25	10.4	P&C	500	34-57	TDT1530 †	15.0	P&C
		TA12608H15	16.1	P&C		66-75	TDT1425 †	15.0	P&C
	68-75	TA10507H25	9.2	P&C		97-120	TA12608H15	15.1	P&C
		TA10507H15	13.0	P&C	600	41-57	TDT1530 †	15.0	P&C
	76-80	TA10507H25	9.4	P&C	700	50-57	TDT1530 †	15.0	P&C
		TA10507H15	13.4	P&C					
	81-90	TA10507H15	13.6	P&C					
	91-120	TA9415H15	10.3	P&C					
300	19-36	TDT1530 †	15.0	---					
	37-52	TDT1425 †	15.0	P&C					
	53-80	TA12608H25	10.7	P&C					
		TA12608H15	16.1	P&C					
	81-83	TA12608H15	15.6	P&C					
	84-115	TA10507H15	13.6	P&C					
116-120	TA9415H15	10.2	P&C						
350	23-42	TDT1530 †	15.0	Fan					
	43-61	TDT1425 †	15.0	P&C					
	62-80	TA12608H25	10.7	P&C					
		TA12608H15	16.1	P&C					
81-103	TA12608H15	15.6	P&C						
104-120	TA10507H15	13.5	P&C						
400	27-50	TDT1530 †	15.0	Fan					
	51-70	TDT1425 †	15.0	P&C					

* See Page G1-132 for lubrication for 15 RPM and slower
 † See DODGE Gear Engineering Catalog DMR-1205-2 for information on TDT1425 and TDT1530 Reducers

P&C (Pump & Coolers) - Use the DODGE Speed Reducer Auxiliary cooling package, part number 014148

Gearing Reference Guide

TORQUE-ARM II

TORQUE-ARM

MAXIMUM Concentric Reducer

TIGEAR-2

FEATURES/BENEFITS PAGE G1-3	NOMENCLATURE PAGE G1-8	SELECTION/DIMENSIONS PAGE G1-36	RELATED PRODUCTS PAGE G1-123
--------------------------------	---------------------------	------------------------------------	---------------------------------



SELECTION

TORQUE-ARM II Shaft Mount Speed Reducers CLASS II SELECTIONS * (SF = 1.4)

Motor HP	Output RPM	Reducer Selection	Min. Sheave Dia. P.D.	Cooling Method	Motor HP	Output RPM	Reducer Selection	Min. Sheave Dia. P.D.	Cooling Method	Motor HP	Output RPM	Reducer Selection	Min. Sheave Dia. P.D.	Cooling Method		
1/4	4-5	TA1107H31	5.0	---	1/2 (cont)	11-50	TA0107L31	4.0	---	1 (cont)	8-11	TA2115H33	3.7	---		
		TA1107H25	6.4	---			TA0107L25	4.0	---			TA2115H25	3.3	---		
		TA1107H15	5.5	---			TA0107L15	4.0	---			TA2115H15	3.3	---		
	6-50	TA0107L31	4.0	---			51-80	TA0107L25	4.0		---	12-21	TA1107H31	4.9	---	
		TA0107L25	4.0	---				TA0107L15	4.0		---		TA1107H25	6.3	---	
		TA0107L15	4.0	---				TA0107L09	5.3		---		TA1107H15	5.5	---	
	51-80	TA0107L25	4.0	---			81-89	TA0107L15	4.0		---	22-50	TA0107L31	4.0	---	
		TA0107L15	4.0	---				TA0107L09	5.3		---		TA0107L25	4.0	---	
	90-120	TA0107L15	4.0	---			90-120	TA0107L09	5.2		---	51-80	TA0107L15	4.0	---	
			4.0	---		TA0107L05		9.2	---		TA0107L15		4.0	---		
		TA0107L09	5.2	---		121-200		TA0107L09	5.0		---		81-89	TA0107L15	4.0	---
		TA0107L05	9.2	---				TA0107L05	8.3		---			TA0107L09	5.3	---
	121-200	TA0107L09	5.0	---		201-400	TA0107L05	6.9	---		90-120	TA0107L15	4.0	---		
		TA0107L05	8.3	---			TA3203H32	4.6	---			TA0107L09	5.2	---		
1/3	4-6	TA1107H31	5.0	---	3/4	4-5	TA3203H25	4.6	---	TA3203H15	4.6	---	TA0107L05	9.2	---	
		TA1107H25	6.4	---			6-8	TA2115H33	3.7		---	TA2115H25		3.3	---	
		TA1107H15	5.5	---				TA2115H15	3.3		---			121-200	TA0107L09	5.0
	7-50	TA0107L31	4.0	---		9-16		TA1107H31	5.0	---	4		TA5215H40		6.8	---
		TA0107L25	4.0	---			TA1107H25	6.4	---	TA5215H25		6.1	---			
		TA0107L15	4.0	---			TA1107H15	5.5	---	TA5215H15		7.1	---			
	51-80	TA0107L25	4.0	---		17-50	TA0107L31	4.0	---	5-7	TA4207H40	5.0	---			
		TA0107L15	4.0	---			TA0107L25	4.0	---		TA4207H25	5.5	---			
	81-89	TA0107L15	4.0	---		51-80	TA0107L15	4.0	---	8-10	TA4207H15	8.1	---			
		TA0107L09	5.3	---			TA0107L09	5.3	---		TA3203H32	4.6	---			
90-120	TA0107L15	4.0	---	81-89	TA0107L25	4.0	---	11-17	TA3203H25	4.6	---					
	TA0107L09	5.2	---		TA0107L15	4.0	---		TA3203H15	4.6	---					
	TA0107L05	9.2	---		TA0107L09	5.3	---		TA2115H33	3.7	---					
	TA0107L05	9.2	---		TA0107L09	5.2	---		TA2115H25	3.3	---					
121-200	TA0107L09	5.0	---	90-120	TA0107L05	9.2	---	18-34	TA2115H15	3.3	---					
	TA0107L05	8.3	---		TA0107L05	9.2	---		TA1107H31	4.8	---					
201-400	TA0107L05	6.9	---	121-200	TA0107L09	5.0	---	35-50	TA1107H25	5.9	---					
	TA0107L05	6.9	---		TA0107L05	8.3	---		TA1107H15	5.3	---					
1/2	4-5	TA2115H33	3.7	---	1	201-400	TA0107L05	6.9	---	1-1/2	51-80	TA0107L31	4.0	---		
		TA2115H25	3.3	---			4	TA0107L25	4.0			---				
		TA2115H15	3.3	---				TA4207H40	5.0			---	TA0107L25	4.0	---	
	6-10	TA1107H31	5.0	---		TA4207H25		5.5	---		TA0107L15	4.0	---			
		TA1107H25	6.4	---		TA4207H15	8.1	---	TA0107L25		4.0	---				
		TA1107H15	5.5	---		TA3203H32	4.6	---	TA0107L15		4.0	---				
* See Page G1-132 for lubrication for 15 RPM and slower	5-7	TA3203H25	4.6	---	TA3203H15	4.6	---	81-89	TA0107L15	4.0	---					
		TA3203H15	4.6	---		TA0107L09	5.3		---							

FEATURES/BENEFITS PAGE G1-3	NOMENCLATURE PAGE G1-8	SELECTION/DIMENSIONS PAGE G1-36	RELATED PRODUCTS PAGE G1-123
--------------------------------	---------------------------	------------------------------------	---------------------------------

SELECTION



TORQUE-ARM II Shaft Mount Speed Reducers

CLASS II SELECTIONS (cont) * (SF = 1.4)

Motor HP	Output RPM	Reducer Selection	Min. Sheave Dia. P.D.	Cooling Method	Motor HP	Output RPM	Reducer Selection	Min. Sheave Dia. P.D.	Cooling Method	Motor HP	Output RPM	Reducer Selection	Min. Sheave Dia. P.D.	Cooling Method		
1-1/2 (cont)	90-120	TA0107L15	4.0	---	3 (cont)	9-14	TA4207H40	5.0	---	5 (cont)	37-50	TA2115H33	3.3	---		
		TA0107L09	5.2	---			TA4207H25	5.5	---			TA2115H25	3.1	---		
		TA0107L05	9.2	---			TA4207H15	8.1	---			TA2115H15	3.2	---		
	121-200	TA0107L09	5.0	---		15-21	TA3203H32	4.5	---		51-67	TA2115H25	3.1	---		
		TA0107L05	8.3	---			TA3203H25	4.5	---			TA2115H15	3.5	---		
		201-400	TA0107L05	6.9			---	TA3203H15	4.5			---	68-80	TA1107H25	5.2	---
4-5	TA5215H40		6.8	---		22-38	TA2115H33	3.6	---		TA1107H15	4.7		---		
	TA5215H25	6.1	---	TA2115H25			3.3	---	81-89		TA1107H15	4.6	---			
	TA5215H15	7.1	---	TA2115H15			3.2	---			TA1107H09	7.7	---			
2	6-9	TA4207H40	5.0	---		39-50	TA1107H31	4.5	---		5 (cont)	90-120	TA1107H15	4.6	---	
		TA4207H25	5.5	---			TA1107H25	5.5	---				TA1107H09	7.5	---	
		TA4207H15	8.1	---			TA1107H15	5.0	---				TA1107H05	12.5	---	
	10-14	TA3203H32	4.6	---		51-73	TA1107H25	5.4	---			121-131	TA1107H09	7.1	---	
		TA3203H25	4.6	---			TA1107H15	4.9	---				TA1107H05	11.2	---	
		TA3203H15	4.6	---			74-80	TA0107L25	4.0				---	132-146	TA0107L09	5.0
	15-24	TA2115H33	3.7	---		TA0107L15		4.0	---			TA1107H05	10.8		---	
		TA2115H25	3.3	---		81-89	TA0107L15	4.0	---			147-200	TA0107L09	4.8	---	
	TA2115H15	3.3	---	TA0107L09			5.3	---	TA0107L05				7.7	---		
	25-46	TA1107H31	4.7	---	90-120	TA0107L15	4.0	---	7-1/2	201-400			TA0107L05	6.9	---	
		TA1107H25	5.7	---		121-200	TA0107L09	5.0				---	4	TA9415H40	8.0	---
		TA1107H15	5.2	---			TA0107L05	9.2				---		TA9415H25	8.0	---
	47-50	TA0107L31	4.0	---	TA0107L09		5.0	---		TA9415H15		10.2		---		
		TA0107L25	4.0	---	TA0107L05	8.3	---	5-6		TA8407H40		6.2	---			
	TA0107L15	4.0	---	201-400	TA0107L05	6.9	---			TA8407H25		6.2	---			
	51-80	TA0107L25	4.0		---	5	4	TA8407H40		6.2		---	TA8407H15	6.2	---	
		TA0107L15	4.0		---			TA8407H25		6.2		---	7-9	TA7315H40	6.2	---
	TA0107L15	4.0	---	TA8407H15	6.2			---		TA7315H25		6.2		---		
81-89	TA0107L09	5.3	---	5-6	TA7315H40		6.2	---		TA7315H15	6.2	---				
	90-120	TA0107L15	4.0		---		TA7315H25	6.2		---	10-13	TA6307H40	6.3	---		
TA0107L09		5.2	---		TA7315H15		6.2	---		TA6307H25		6.3	---			
TA0107L05	9.2	---	7-8	TA6307H40	6.3		---	TA6307H15		6.4		---				
121-200	TA0107L09	5.0		---	TA6307H25		6.3	---		14-21	TA5215H40	6.7	---			
	TA0107L05	8.3	---	TA6307H15	6.4		---	TA5215H25			6.0	---				
201-400	TA0107L05	6.9	---	TA5215H40	6.8		---	TA5215H15			7.0	---				
3	4-5	TA6307H40	6.3	---	24-36		9-14	TA5215H25		6.1	---	7-1/2	22-35	TA4207H40	4.7	---
		TA6307H25	6.3	---				TA5215H15		7.1	---			TA4207H25	5.2	---
		TA6307H15	6.4	---				TA4207H15	4.9	---	TA4207H15			7.7	---	
	6-8	TA5215H40	6.8	---			15-23	TA4207H25	5.4	---	36-50		TA3203H32	4.1	---	
		TA5215H25	6.1	---				TA4207H15	7.9	---			TA3203H25	4.3	---	
		TA5215H15	7.1	---				TA3203H32	4.3	---			TA3203H15	4.3	---	
* See Page G1-132 for lubrication for 15 RPM and slower										51-58	TA3203H25	4.2	---			
											TA3203H15	4.2	---			

FEATURES/BENEFITS PAGE G1-3	NOMENCLATURE PAGE G1-8	SELECTION/DIMENSIONS PAGE G1-36	RELATED PRODUCTS PAGE G1-123
--------------------------------	---------------------------	------------------------------------	---------------------------------



SELECTION

TORQUE-ARM II Shaft Mount Speed Reducers

CLASS II SELECTIONS (cont) * (SF = 1.4)

Motor HP	Output RPM	Reducer Selection	Min. Sheave Dia. P.D.	Cooling Method	Motor HP	Output RPM	Reducer Selection	Min. Sheave Dia. P.D.	Cooling Method	Motor HP	Output RPM	Reducer Selection	Min. Sheave Dia. P.D.	Cooling Method	
7-1/2 (cont)	59-80	TA2115H25	3.1	---	10 (cont)	30-49	TA4207H40	4.5	---	15 (cont)	27-47	TA5215H40	6.4	---	
		TA2115H15	3.6	---			TA4207H25	5.0	---			TA5215H25	5.7	---	
	81-89	TA2115H15	3.7	---		50	TA4207H15	7.4	---		48-50	TA5215H15	6.6	---	
		TA2115H09	6.1	---			TA3203H32	4.0	---			TA4207H40	4.2	---	
	90-105	TA2115H15	3.7	---		51-80	TA3203H25	4.2	---		51-80	TA4207H25	4.7	---	
		TA2115H09	6.2	---			TA3203H15	4.2	---			TA4207H15	6.9	---	
	106-108	TA2115H05	6.5	---		81-84	TA3203H25	4.2	---		81	TA4207H25	4.7	---	
		TA1107H15	4.5	---			TA3203H15	4.2	---			TA4207H15	6.8	---	
	109-120	TA2115H09	6.2	---		85-89	TA3203H15	4.0	---		82-89	TA3203H15	4.0	---	
		TA2115H05	6.5	---			TA2115H15	3.7	---			TA3203H09	5.2	---	
	121-127	TA1107H15	4.5	---		90-120	TA2115H09	6.1	---		90-92	TA3203H15	4.0	---	
		TA1107H09	7.3	---			TA2115H05	6.2	---			TA3203H09	5.3	---	
	128-200	TA2115H05	6.6	---		121-127	TA3203H05	11.0	---		93-118	TA5215H05	13.9	---	
		TA1107H09	7.1	---			TA2115H09	6.2	---			TA3203H15	4.0	---	
201-306	TA1107H05	10.9	---	128-162	TA2115H05	6.5	---	119-120	TA3203H09	5.6	---				
	TA1107H05	10.9	---		TA1107H09	6.5	---		TA3203H05	7.7	---				
307-400	TA0107L05	5.5	---	163-200	TA2115H05	6.0	---	121-149	TA3203H09	5.7	---				
					TA1107H05	8.9	---		TA3203H05	7.7	---				
10	4	TA10507H40	8.5	---	15	4	TA12608H40	17.2	---	20	4	TDT1425 †	15.0	---	
		TA10507H25	8.5	---			TA12608H25	9.5	---			5	TA12608H40	17.2	---
		TA10507H15	10.8	---			TA12608H15	13.7	---				TA12608H25	9.5	---
	5	TA9415H40	8.0	---		5-6	TA10507H40	8.5	---		6-8		TA10507H40	8.5	---
		TA9415H25	8.0	---			TA10507H25	8.5	---			TA10507H25	8.5	---	
		TA9415H15	10.2	---			TA10507H15	10.8	---			TA10507H15	10.8	---	
	6-8	TA8407H40	6.2	---		7-8	TA9415H40	8.0	---		9-11	TA9415H40	8.0	---	
		TA8407H25	6.2	---			TA9415H25	8.0	---			TA9415H25	8.0	---	
		TA8407H15	6.2	---			TA9415H15	10.2	---			TA9415H15	10.3	---	
	9-12	TA7315H40	6.2	---		9-12	TA8407H40	6.2	---		12-17	TA8407H40	6.2	---	
		TA7315H25	6.2	---			TA8407H25	6.2	---			TA8407H25	6.2	---	
		TA7315H15	6.2	---			TA8407H15	6.2	---			TA8407H15	6.2	---	
	13-17	TA6307H40	6.3	---		13-19	TA7315H40	6.2	---		20-26	TA6307H40	6.3	---	
		TA6307H25	6.3	---			TA7315H25	6.2	---			TA6307H25	6.3	---	
TA6307H15		6.3	---	TA7315H15	6.2		---	TA6307H15	6.3	---					
18-29	TA5215H40	6.6	---												
	TA5215H25	5.9	---												
	TA5215H15	6.8	---												

* See Page G1-132 for lubrication for 15 RPM and slower

† See DODGE Gear Engineering Catalog DMR-1205-2 for information on TDT1425 and TDT1530 Reducers

FEATURES/BENEFITS PAGE G1-3	NOMENCLATURE PAGE G1-8	SELECTION/DIMENSIONS PAGE G1-36	RELATED PRODUCTS PAGE G1-123
--------------------------------	---------------------------	------------------------------------	---------------------------------

SELECTION



TORQUE-ARM II Shaft Mount Speed Reducers

CLASS II SELECTIONS (cont) * (SF = 1.4)

Motor HP	Output RPM	Reducer Selection	Min. Sheave Dia. P.D.	Cooling Method	Motor HP	Output RPM	Reducer Selection	Min. Sheave Dia. P.D.	Cooling Method	Motor HP	Output RPM	Reducer Selection	Min. Sheave Dia. P.D.	Cooling Method
20 (cont)	18-26	TA7315H40	6.2	---	25 (cont)	11-14	TA9415H40	8.0	---	30 (cont)	13-18	TA9415H40	8.0	---
		TA7315H25	6.2	---			TA9415H25	8.0	---			TA9415H25	8.0	---
		TA7315H15	6.2	---			TA9415H15	10.4	---			TA9415H15	10.6	---
	27-36	TA6307H40	6.3	---		15-21	TA8407H40	6.2	---		19-26	TA8407H40	6.2	---
		TA6307H25	6.3	---			TA8407H25	6.2	---			TA8407H25	6.2	---
		TA6307H15	6.3	---			TA8407H15	6.2	---			TA8407H15	6.2	---
	37-50	TA5215H40	6.2	---		22-33	TA7315H40	6.2	---		27-41	TA7315H40	6.2	---
		TA5215H25	5.6	---			TA7315H25	6.2	---			TA7315H25	6.2	---
		TA5215H15	6.5	---			TA7315H15	6.2	---			TA7315H15	6.2	---
	51-67	TA5215H25	5.4	---		34-46	TA6307H40	6.2	---		42-50	TA6307H40	6.2	---
		TA5215H15	6.3	---			TA6307H25	6.2	---			TA6307H25	6.2	---
	68-80	TA4207H25	4.5	---		47-50	TA6307H15	6.2	---		51-56	TA6307H15	6.2	---
		TA4207H15	6.6	---			TA5215H40	6.1	---			TA6307H25	6.2	---
	81-89	TA4207H15	6.4	---		51-80	TA5215H25	5.5	---		57-80	TA5215H25	5.4	---
TA4207H09		10.1	---	TA5215H15	6.3		---	TA5215H15	6.2	---				
90-115	TA4207H15	6.3	---	81-87	TA5215H25	5.4	---	81-89	TA5215H15	6.0	---			
	TA4207H09	9.9	---		TA5215H15	6.3	---		TA5215H09	9.1	---			
	TA5215H05	13.9	---		TA5215H09	9.1	---		TA5215H15	6.0	---			
116-120	TA4207H15	5.9	---	88-89	TA4207H15	6.3	---	90-110	TA5215H15	5.7	---			
	TA3203H09	5.6	---		TA5215H09	8.9	---		TA5215H09	8.9	---			
	TA5215H05	12.1	---		TA5215H09	8.9	---		TA5215H05	13.9	---			
121-123	TA3203H09	5.6	---	90-91	TA4207H15	6.3	---	111-114	TA4207H15	6.0	---			
	TA5215H05	11.8	---		TA5215H09	8.9	---		TA5215H09	8.5	---			
124-194	TA3203H09	5.7	---	92-120	TA5215H05	13.9	---	115-120	TA5215H05	12.4	---			
	TA4207H05	9.3	---		TA4207H15	6.3	---		TA4207H15	5.9	---			
195-200	TA3203H09	5.5	---	121-154	TA4207H09	9.8	---	196-200	TA4207H09	9.4	---			
	TA3203H05	7.0	---		TA5215H05	13.7	---		TA5215H05	12.1	---			
201-400	TA3203H05	7.0	---	155-200	TA4207H09	9.3	---	201-348	TA4207H09	9.3	---			
	TA3203H05	7.0	---		TA5215H05	11.8	---		TA5215H05	11.8	---			
25	4-6	TDT1425 †	15.0	---	201-269	TA4207H09	8.7	---	349-400	TA4207H09	7.8	---		
		TA12608H40	17.2	---		TA4207H05	9.2	---		TA4207H05	9.2	---		
		TA12608H25	9.5	---		TA4207H05	9.8	---	TA4207H05	9.8	---			
	TA12608H15	13.7	---	TA3203H05		7.0	---	TA3203H05	7.0	---				
8-10	TA10507H40	8.5	---	270-400	TA10507H40	8.5	---	40	TA10507H40	8.5	---			
	TA10507H25	8.5	---		TA10507H25	8.5	---		TA10507H25	8.5	---			
* See Page G1-132 for lubrication for 15 RPM and slower † See DODGE Gear Engineering Catalog DMR-1205-2 for information on TDT1425 and TDT1530 Reducers					30	4	TDT1530 †	15.0	---	40	4-6	TDT1530 †	15.0	---
						5-7	TDT1425 †	15.0	---		7-9	TDT1425 †	15.0	---
						8	TA12608H40	17.2	---		10-12	TA12608H40	17.2	---
							TA12608H25	9.5	---			TA12608H25	9.5	---
9-12	TA12608H15	13.7	---	13-17	TA12608H15	13.9	---							
	TA10507H40	8.5	---		TA10507H40	8.5	---							
										TA10507H25	8.5	---		
										TA10507H15	10.8	---		

FEATURES/BENEFITS PAGE G1-3	NOMENCLATURE PAGE G1-8	SELECTION/DIMENSIONS PAGE G1-36	RELATED PRODUCTS PAGE G1-123
--------------------------------	---------------------------	------------------------------------	---------------------------------

Gearing Reference Guide

TORQUE-ARM II

TORQUE-ARM

MAXIMUM Concentric Reducer

TIGEAR-2



SELECTION

TORQUE-ARM II Shaft Mount Speed Reducers

CLASS II SELECTIONS (cont) * (SF = 1.4)

Motor HP	Output RPM	Reducer Selection	Min. Sheave Dia. P.D.	Cooling Method	Motor HP	Output RPM	Reducer Selection	Min. Sheave Dia. P.D.	Cooling Method	Motor HP	Output RPM	Reducer Selection	Min. Sheave Dia. P.D.	Cooling Method			
40 (cont)	18-24	TA9415H40	8.0	---	50 (cont)	16-21	TA10507H40	8.5	---	60 (cont)	15-18	TA12608H40	17.1	---			
		TA9415H25	8.0	---			TA10507H25	8.5	---			TA12608H25	9.5	---			
		TA9415H15	10.7	---			TA10507H15	10.8	---			TA12608H15	14.3	---			
	25-36	TA8407H40	6.2	---		22-31	TA9415H40	8.0	---		19-26	TA10507H40	8.5	---	TA10507H40	8.5	---
		TA8407H25	6.2	---			TA9415H25	8.0	---			TA10507H25	8.5	---			
		TA8407H15	6.2	---			TA9415H15	10.8	---			TA10507H15	10.8	---			
	37-50	TA7315H40	6.2	---		32-43	TA8407H40	6.2	---		27-38	TA9415H40	8.0	Fan	TA9415H40	8.0	---
		TA7315H25	6.2	---			TA8407H25	6.2	---			TA9415H25	8.0	---			
		TA7315H15	6.2	---			TA8407H15	6.2	---			TA9415H15	10.8	---			
	51-56	TA7315H25	6.2	---		44-46	TA8407H40	6.2	Fan		39-50	TA8407H40	6.2	Fan	TA8407H40	6.2	---
		TA7315H15	6.2	---			TA8407H25	6.2	---			TA8407H25	6.2	---			
	57-78	TA6307H25	6.2	---		47-50	TA8407H15	6.2	---		51-56	TA8407H15	6.2	---	TA8407H25	6.2	---
		TA6307H15	6.2	---			TA7315H40	6.2	---			TA8407H15	6.5	---			
	79-80	TA5215H25	5.2	---		51-71	TA7315H25	6.2	---		57-80	TA7315H25	6.2	---	TA7315H25	6.2	---
		TA5215H15	6.0	---			TA7315H15	6.2	---			TA7315H15	6.2	---			
	81-85	TA5215H15	6.0	---		72-80	TA6307H25	6.2	---		81-89	TA7315H15	6.2	---	TA7315H15	6.2	---
		TA6307H09	9.8	---			TA6307H15	6.2	---			TA7315H09	8.1	---			
	86-89	TA5215H15	5.8	---		81-89	TA6307H15	6.3	---		90-120	TA6307H15	6.7	---	TA6307H15	6.7	---
TA5215H09		9.0	---	TA6307H09	9.9		---	TA6307H09	10.8	---							
90-112	TA5215H15	5.7	---	90-91	TA6307H15	6.3	---	121	TA6307H09	10.8	---	TA6307H09	10.8	---			
	TA5215H09	8.9	---		TA6307H15	6.3	---		TA7315H05	12.8	---						
	TA6307H05	15.1	---		TA6307H09	10.0	---		TA7315H05	12.8	---						
113-120	TA5215H15	5.1	---	92-114	TA6307H15	6.6	---	122-195	TA6307H09	10.9	---	TA6307H09	10.9	---			
	TA5215H09	8.4	---		TA6307H05	15.1	---		TA6307H05	14.5	---						
121-173	TA5215H09	8.3	---	115-116	TA6307H15	6.7	---	196-199	TA6307H09	10.1	Fan	TA6307H09	10.1	Fan			
	TA5215H05	11.8	---		TA5215H09	8.4	---		TA6307H05	13.9	---						
174-200	TA4207H09	8.2	---	201-299	TA6307H05	14.7	---	200	TA5215H09	5.8	---	TA5215H09	5.8	---			
	TA5215H05	10.4	---		TA6307H05	14.7	---		TA6307H05	13.8	---						
201-299	TA5215H05	9.9	---	300-400	TA5215H09	8.4	---	201-282	TA6307H05	13.8	---	TA6307H05	13.8	---			
	TA4207H05	8.8	---		TA6307H05	14.7	---		TA5215H05	8.4	---						
50	5-8	TDT1530 †	15.0	---	117-120	TA5215H15	5.1	---	75	7-12	TDT1530 †	15.0	---				
	9-12	TDT1425 †	15.0	---		TA5215H09	8.4	---		13-18	TDT1425 †	15.0	---				
	13-15	TA12608H40	17.1	---		TA6307H05	14.6	---		19-23	TA12608H40	17.1	---				
		TA12608H25	9.5	---		TA5215H09	8.3	---			TA12608H25	9.5	---				
* See Page G1-132 for lubrication for 15 RPM and slower † See DODGE Gear Engineering Catalog DMR-1205-2 for information on TDT1425 and TDT1530 Reducers					60	TA12608H15	14.1	---	TA6307H05	14.5	---	TA12608H15	14.6	---			
						178-200	TA5215H09	6.3	---	24	TA10507H40	8.5	---				
						201-400	TA5215H05	10.4	---		TA12608H25	9.5	---				
						25-33	TA10507H40	8.5	---								
							TA10507H25	8.5	---								
						10-14	TDT1425 †	15.0	---	TA12608H15	14.7	---					
10-14	TDT1425 †	15.0	---	TA10507H15	10.7	---											

FEATURES/BENEFITS PAGE G1-3	NOMENCLATURE PAGE G1-8	SELECTION/DIMENSIONS PAGE G1-36	RELATED PRODUCTS PAGE G1-123
--------------------------------	---------------------------	------------------------------------	---------------------------------

SELECTION



TORQUE-ARM II Shaft Mount Speed Reducers

CLASS II SELECTIONS (cont) * (SF = 1.4)

Motor HP	Output RPM	Reducer Selection	Min. Sheave Dia. P.D.	Cooling Method	Motor HP	Output RPM	Reducer Selection	Min. Sheave Dia. P.D.	Cooling Method	Motor HP	Output RPM	Reducer Selection	Min. Sheave Dia. P.D.	Cooling Method															
75 (cont)	34-48	TA9415H40	8.0	Fan	100 (cont)	34-45	TA10507H40	8.5	Fan	150 (cont)	37-50	TA12608H40	17.1	P&C															
		TA9415H25	8.0	Fan			TA10507H25	8.5	---			TA12608H25	9.5	Fan															
		TA9415H15	10.8	---			TA10507H15	11.1	---			TA12608H15	15.7	Fan															
	49	TA8407H40	6.2	Fan		46-50	TA9415H40	8.0	Fan		51-54	TA12608H25	9.6	Fan															
		TA8407H25	6.2	Fan			TA9415H25	8.0	Fan			TA12608H15	15.8	Fan															
		TA9415H15	10.8	---			TA9415H15	10.8	Fan			55-71	TA10507H25	9.0	Fan														
	50	TA8407H40	6.2	Fan		51-67	TA9415H25	8.0	Fan		TA10507H15		12.7	Fan															
		TA8407H25	6.2	Fan			TA9415H15	10.8	Fan		72	TA9415H25	8.0	P&C															
		TA8407H15	6.2	---			TA8407H25	6.2	Fan			TA10507H15	12.8	Fan															
	51-72	TA8407H25	6.2	Fan		68-80	TA8407H15	7.5	Fan		73-80	TA9415H25	8.0	P&C															
		TA8407H15	7.2	---			TA8407H15	8.3	Fan			TA9415H15	10.6	Fan															
	73-80	TA7315H25	6.2	Fan		81-102	TA8407H15	8.3	Fan		81-105	TA9415H15	10.5	Fan															
		TA7315H15	6.2	---			103	TA7315H15	6.2			Fan	TA8407H15	8.7	Fan														
	81-111	TA7315H15	6.2	---		104-120	TA7315H15	6.2	Fan		106-120	TA7315H09	8.2	Fan															
		TA7315H09	8.5	---			TA7315H09	8.5	Fan			TA7315H09	8.2	Fan															
	112-117	TA7315H15	6.2	---		121-180	TA7315H09	8.6	Fan		189-200	TA7315H05	10.1	---															
TA7315H09		8.5	---	181-190	TA6307H09		10.4	Fan	368-400	TA7315H05		10.1	---																
118-120	TA6307H15	6.7	Fan	191-200	TA6307H09	10.2	Fan	50	TA12608H40	17.1	P&C																		
	TA6307H09	10.8	Fan		TA7315H05	11.7	---		TA12608H25	9.5	P&C																		
	TA6307H09	10.9	Fan		TA7315H05	11.7	---		TA12608H15	15.7	Fan																		
121-169	TA6307H09	10.7	Fan	201-274	TA6307H05	12.0	---	51-76	TA12608H25	10.7	P&C																		
	TA7315H05	12.8	---		275-400	TA6307H05	12.0		---	TA12608H15	16.1	Fan																	
100	8-16	TDT1530 †	15.0	---	125	11-20	TDT1530 †	15.0	---	200	18-33	TDT1530 †	15.0	---															
		TDT1425 †	15.0	---			21-30	TDT1425 †	15.0			---	34-49	TDT1425 †	15.0	Fan													
	25-32	TA12608H40	17.1	---		31-41	TA12608H40	17.1	Fan		77-80	TA10507H25	9.4	P&C															
		TA12608H25	9.5	---			TA12608H25	9.5	---			TA10507H15	13.4	Fan															
		TA12608H15	15.1	---			TA12608H15	15.4	---			81-105	TA10507H15	13.6	Fan														
	33	TA10507H40	8.5	Fan		42-43	TA10507H40	8.5	Fan		106-120	TA9415H15	10.2	P&C															
		TA12608H25	9.5	---			TA12608H25	9.5	---			23-42	TDT1530 †	15.0	---														
	TA12608H15	15.1	---	44-50		TA10507H40	8.5	Fan	43-61		TDT1425 †	15.0	P&C																
	TA10507H15	15.1	---			TA10507H25	8.5	Fan			62-80	TA12608H25	10.7	P&C															
	* See Page G1-132 for lubrication for 15 RPM and slower † See DODGE Gear Engineering Catalog DMR-1205-2 for information on TDT1425 and TDT1530 Reducers P&C (Pump & Coolers - Use the DODGE Speed Reducer Auxiliary cooling package, part number 014148	100	100	100		100	125	125	125		125	125	250	250	250	250	250												
TA10507H15					11.8					Fan								81-103	TA12608H15	15.6	P&C								
59-80					TA9415H25					8.0								Fan	104-120	TA10507H15	13.5	P&C							
81-85					TA9415H15					10.5								Fan	28-53	TDT1530 †	15.0	---							
86-120					TA8407H15					8.7								Fan		54-75	TDT1425 †	15.0	P&C						
141-200					TA7315H09					8.6								Fan	76-80	TA12608H25	10.7	P&C							
272-400					TA7315H05					10.9								---		TA12608H15	15.8	P&C							
13-25					TDT1530 †					15.0								---	81-120	TA12608H15	15.6	P&C							
					26-36					TDT1425 †								15.0		---	33-57	TDT1530 †	15.0	---					
150					150					150								150	150	150	150	150	150	150	350	350	350	350	350
94-120					TA12608H15					15.2								P&C											

FEATURES/BENEFITS PAGE G1-3	NOMENCLATURE PAGE G1-8	SELECTION/DIMENSIONS PAGE G1-36	RELATED PRODUCTS PAGE G1-123
--------------------------------	---------------------------	------------------------------------	---------------------------------



SELECTION

TORQUE-ARM II Shaft Mount Speed Reducers

CLASS II SELECTIONS (cont) * (SF = 1.4)

Motor HP	Output RPM	Reducer Selection	Min. Sheave Dia. P.D.	Cooling Method
400	38-57	TDT1530 †	15.0	Fan
	114-120	TA12608H15	15.1	P&C
450	43-57	TDT1530 †	15.0	Fan
500	50-57	TDT1530 †	15.0	Fan

* See Page G1-132 for lubrication for 15 RPM and slower

† See DODGE Gear Engineering Catalog DMR-1205-2 for information on TDT1425 and TDT1530 Reducers

P&C (Pump & Coolers) - Use the DODGE Speed Reducer Auxiliary cooling package, part number 014148

SELECTION



TORQUE-ARM II Shaft Mount Speed Reducers CLASS III SELECTIONS * (SF = 2.0)

Motor HP	Output RPM	Reducer Selection	Min. Sheave Dia. P.D.	Cooling Method	Motor HP	Output RPM	Reducer Selection	Min. Sheave Dia. P.D.	Cooling Method	Motor HP	Output RPM	Reducer Selection	Min. Sheave Dia. P.D.	Cooling Method
1/4	4	TA2115H33	3.7	---	1/2	4-5	TA3203H32	4.6	---	3/4 (cont)	90-120	TA0107L15	4.0	---
		TA2115H25	3.3	---			TA3203H25	4.6	---			TA0107L09	5.2	---
		TA2115H15	3.3	---			TA3203H15	4.6	---			TA0107L05	9.2	---
	5-7	TA1107H31	5.0	---		6-8	TA2115H33	3.7	---		121-200	TA0107L09	5.0	---
		TA1107H25	6.4	---			TA2115H25	3.3	---			TA0107L05	8.3	---
		TA1107H15	5.5	---			TA2115H15	3.3	---			201-400	TA0107L05	6.9
	8-50	TA0107L31	4.0	---		9-15	TA1107H31	5.0	---	4	TA5215H40	6.8	---	
		TA0107L25	4.0	---			TA1107H25	6.4	---		TA5215H25	6.1	---	
		TA0107L15	4.0	---			TA1107H15	5.5	---		TA5215H15	7.1	---	
	51-80	TA0107L25	4.0	---		16-50	TA0107L31	4.0	---	5-6	TA4207H40	5.0	---	
		TA0107L15	4.0	---			TA0107L25	4.0	---		TA4207H25	5.5	---	
	81-89	TA0107L15	4.0	---			TA0107L15	4.0	---	TA4207H15	8.1	---		
		TA0107L09	5.3	---		51-80	TA0107L25	4.0	---	7-10	TA3203H32	4.6	---	
	90-120	TA0107L15	4.0	---			TA0107L15	4.0	---		TA3203H25	4.6	---	
TA0107L09		5.2	---	81-89	TA0107L15	4.0	---	TA3203H15	4.6		---			
TA0107L05		9.2	---		TA0107L09	5.3	---	11-16	TA2115H33	3.7	---			
121-200	TA0107L09	5.0	---	TA0107L15	4.0	---	TA2115H25		3.3	---				
	TA0107L05	8.3	---	TA0107L09	5.2	---	TA2115H15		3.3	---				
201-400	TA0107L05	6.9	---	TA0107L05	9.2	---	17	TA1107H31	4.8	---				
1/3	4-5	TA2115H33	3.7	---	121-200	TA0107L09		5.0	---	TA2115H25	3.3	---		
		TA2115H25	3.3	---	TA0107L05	8.3		---	TA1107H15	5.4	---			
		TA2115H15	3.3	---	201-400	TA0107L05	6.9	---	TA1107H31	4.8	---			
	6-9	TA1107H31	5.0	---	3/4	4-5	TA4207H40	5.0	---	1	18-32	TA1107H31	4.8	---
		TA1107H25	6.4	---			TA4207H25	5.5	---			TA1107H25	5.9	---
		TA1107H15	5.5	---			TA4207H15	8.1	---			TA1107H15	5.3	---
	10-50	TA0107L31	4.0	---		6-7	TA3203H32	4.6	---	33-50	TA0107L31	4.0	---	
		TA0107L25	4.0	---			TA3203H25	4.6	---		TA0107L25	4.0	---	
	TA0107L15	4.0	---	TA3203H15			4.6	---	TA0107L15	4.0	---			
	51-80	TA0107L25	4.0	---		8-12	TA2115H33	3.7	---	51-80	TA0107L25	4.0	---	
		TA0107L15	4.0	---			TA2115H25	3.3	---		TA0107L15	4.0	---	
	81-89	TA0107L15	4.0	---			TA2115H15	3.3	---	81-89	TA0107L15	4.0	---	
		TA0107L09	5.3	---		TA1107H31	4.9	---	TA0107L09		5.3	---		
	90-120	TA0107L15	4.0	---		13-23	TA1107H25	6.2	---	90-120	TA0107L15	4.0	---	
TA0107L09		5.2	---	TA1107H15			5.5	---	TA0107L09		5.2	---		
TA0107L05		9.2	---	TA0107L31			4.0	---	TA0107L05		9.2	---		
121-200	TA0107L09	5.0	---	24-50		TA0107L25	4.0	---	121-200	TA0107L09	5.0	---		
	TA0107L05	8.3	---		TA0107L15	4.0	---	TA0107L05		8.3	---			
201-400	TA0107L05	6.9	---	51-80	TA0107L25	4.0	---	201-400	TA0107L05	6.9	---			
* See Page G1-132 for lubrication for 15 RPM and slower	81-89	TA0107L15	4.0		---	TA0107L15	4.0		---	1-1/2	4-6	TA5215H40	6.8	---
		TA0107L09	5.3	---	TA0107L15	4.0	---	TA5215H25	6.1			---		
		TA0107L09	5.3	---	TA0107L09	5.3	---	TA5215H15	7.1			---		

FEATURES/BENEFITS PAGE G1-3	NOMENCLATURE PAGE G1-8	SELECTION/DIMENSIONS PAGE G1-36	RELATED PRODUCTS PAGE G1-123
--------------------------------	---------------------------	------------------------------------	---------------------------------

Gearing Reference Guide

TORQUE-ARM II

TORQUE-ARM

MAXIMUM Concentric Reducer

TIGEAR-2



SELECTION

TORQUE-ARM II Shaft Mount Speed Reducers

CLASS III SELECTIONS (cont) * (SF = 2.0)

Motor HP	Output RPM	Reducer Selection	Min. Sheave Dia. P.D.	Cooling Method	Motor HP	Output RPM	Reducer Selection	Min. Sheave Dia. P.D.	Cooling Method	Motor HP	Output RPM	Reducer Selection	Min. Sheave Dia. P.D.	Cooling Method			
1-1/2 (cont)	7-10	TA4207H40	5.0	---	2 (cont)	51-69	TA1107H25	5.4	---	3 (cont)	110-113	TA1107H15	4.5	---			
		TA4207H25	5.5	---			TA1107H15	4.9	---			TA0107L09	5.1	---			
		TA4207H15	8.1	---			TA0107L25	4.0	---			TA1107H05	11.6	---			
	11-15	TA3203H32	4.6	---			70-80	TA0107L15	4.0			---	114	TA0107L15	4.0	---	
		TA3203H25	4.6	---				TA0107L15	4.0			---		TA0107L09	5.1	---	
		TA3203H15	4.6	---				TA0107L09	5.3			---		TA1107H05	11.4	---	
	16-26	TA2115H33	3.7	---		90-120	TA0107L15	4.0	---		115-120	TA0107L15	4.0	---			
		TA2115H25	3.3	---			TA0107L09	5.2	---			TA0107L09	5.1	---			
		TA2115H15	3.2	---			TA0107L05	9.2	---			TA0107L05	8.4	---			
	27-50	TA1107H31	4.6	---		121-200	TA0107L09	5.0	---		121-200	TA0107L09	5.0	---			
		TA1107H25	5.7	---			TA0107L05	8.3	---			TA0107L05	8.3	---			
		TA1107H15	5.2	---			201-400	TA0107L05	6.9			---	201-400	TA0107L05	6.9	---	
	2	51-80	TA0107L25	4.0		---	3	4-5	TA7315H40		6.2	---	5	4	TA9415H40	8.0	---
			TA0107L15	4.0		---			TA7315H25		6.2	---			TA9415H25	8.0	---
81-89		TA0107L15	4.0	---	TA7315H15	6.2			---	TA9415H15	10.2	---					
		TA0107L09	5.3	---	6-7	TA6307H40		6.3	---	5	TA8407H40	6.2		---			
90-120		TA0107L15	4.0	---		TA6307H25		6.3	---		TA8407H25	6.2		---			
		TA0107L09	5.2	---	TA6307H15	6.4		---	TA8407H15	6.2	---						
121-200		TA0107L05	9.2	---	8-12	TA5215H40		6.8	---	6-8	TA7315H40	6.2		---			
		TA0107L09	5.0	---		TA5215H25		6.1	---		TA7315H25	6.2		---			
3		4-5	TA0107L05	8.3	---	3		13-20	TA5215H15	7.1	---	5		9-12	TA7315H15	6.2	---
			TA0107L05	6.9	---				TA4207H40	4.9	---				TA6307H40	6.3	---
	6-8		TA6307H40	6.3	---		TA4207H25		5.5	---	TA6307H25		6.3		---		
		TA6307H25	6.3	---	TA4207H15		8.0	---	TA6307H15	6.4	---						
	9-13	TA6307H15	6.4	---	21-30		TA3203H32	4.3	---	13-20	TA5215H40		6.7	---			
		TA5215H40	6.8	---			TA3203H25	4.4	---		TA5215H25		6.0	---			
	14-20	TA5215H25	6.1	---	TA3203H15		4.4	---	TA5215H15	7.0	---						
		TA5215H15	7.1	---	31		TA3203H32	4.1	---	21-33	TA4207H40		4.7	---			
		21-36	TA4207H40	5.0			---	TA2115H25	3.1		---		TA4207H25	5.2	---		
	TA4207H25		5.5	---	TA2115H15		3.1	---	TA4207H15	7.7	---						
TA4207H15	8.1	---	32-50	TA2115H33	3.5	---	34-50	TA3203H32	4.1	---							
TA3203H32	4.5	---		TA2115H25	3.1	---		TA3203H25	4.3	---							
21-36	TA3203H25	4.5	---	TA2115H15	3.2	---	51-55	TA3203H15	4.3	---							
	TA3203H15	4.6	---	51-56	TA2115H25	3.1		---	TA3203H25	4.2	---						
	TA2115H33	3.6	---		TA2115H15	3.3		---	TA3203H15	4.2	---						
37-50	TA2115H25	3.3	---	57-80	TA1107H25	5.3	---	56-80	TA2115H25	3.1	---						
	TA2115H15	3.2	---		TA1107H15	4.8	---		TA2115H15	3.6	---						
	TA1107H31	4.5	---	81-89	TA1107H15	4.6	---	81-89	TA2115H15	3.7	---						
TA1107H25	5.6	---	TA1107H09		7.7	---	TA2115H09		6.1	---							
* See Page G1-132 for lubrication for 15 RPM and slower	90-109	TA1107H15	5.0	---	TA1107H15	4.6	---	90-100	TA2115H15	3.7	---						
		TA1107H09	7.5	---	TA1107H05	12.5	---		TA2115H09	6.2	---						

FEATURES/BENEFITS PAGE G1-3	NOMENCLATURE PAGE G1-8	SELECTION/DIMENSIONS PAGE G1-36	RELATED PRODUCTS PAGE G1-123
--------------------------------	---------------------------	------------------------------------	---------------------------------

SELECTION



TORQUE-ARM II Shaft Mount Speed Reducers CLASS III SELECTIONS (cont) * (SF = 2.0)

Motor HP	Output RPM	Reducer Selection	Min. Sheave Dia. P.D.	Cooling Method	Motor HP	Output RPM	Reducer Selection	Min. Sheave Dia. P.D.	Cooling Method	Motor HP	Output RPM	Reducer Selection	Min. Sheave Dia. P.D.	Cooling Method				
5 (cont)	101	TA1107H15	4.5	---	7-1/2 (cont)	54-80	TA3203H25	4.1	---	10 (cont)	51-75	TA4207H25	4.7	---				
		TA2115H09	6.2	---			TA3203H15	4.2	---			TA4207H15	6.8	---				
		TA2115H05	6.5	---		TA3203H15	4.0	---	TA3203H25		4.0	---						
	102-118	TA1107H15	4.5	---		81-89	TA3203H09	5.2	---		76-80	TA3203H15	4.1	---	81-89	TA3203H15	4.0	---
		TA1107H09	7.4	---			TA3203H15	4.0	---			TA3203H09	5.2	---				
		TA2115H05	6.6	---		90-92	TA3203H09	5.3	---		90-105	TA3203H15	4.0	---	TA3203H09	5.4	---	
	119-120	TA1107H15	4.4	---			93-120	TA3203H05	11.0			---	TA4207H05	9.9	---	106-120	TA3203H15	4.0
		TA1107H09	7.1	---		TA2115H15		3.7	---		TA3203H09	5.6	---					
		TA1107H05	11.2	---		TA2115H09	6.2	---	TA4207H05		9.9	---						
	121-200	TA1107H09	7.1	---		121-143	TA3203H05	10.4	---		121-141	TA3203H15	4.0	---	142-200	TA3203H15	4.0	---
TA1107H05		11.2	---	TA2115H09	6.1		---	TA3203H09	5.6	---								
201-276		TA1107H05	9.1	---	TA3203H05	7.7	---	TA3203H05	8.6	---								
277-400	TA0107L05	5.8	---	144-181	TA2115H09	6.3	---	201-238	TA3203H05	7.0	---	239-400	TA2115H05	5.7	---			
7-1/2	4	TA10507H40	8.5	---	182-200	TA2115H05	6.4	---	238-400	TA1107H05	8.4	---	4-5	TDT1425 †	15.0	---		
		TA10507H25	8.5	---		201-237	TA2115H05	6.0		---	TA12608H40	17.2		---				
		TA10507H15	10.8	---		TA2115H05	6.2	---		TA12608H25	9.5	---						
	5-6	TA9415H40	8.0	---	201-237	TA2115H05	6.0	---	238-400	TA1107H05	8.4	---	6	TA12608H40	17.2	---		
		TA9415H25	8.0	---		TA2115H05	6.2	---		TA12608H25	9.5	---						
		TA9415H15	10.2	---		TA2115H05	6.2	---		TA12608H15	13.7	---						
	7-8	TA8407H40	6.2	---	182-200	TA2115H05	6.2	---	238-400	TA1107H05	8.4	---	7-9	TA10507H40	8.5	---		
		TA8407H25	6.2	---		TA2115H05	6.2	---		TA10507H25	8.5	---						
		TA8407H15	6.2	---		TA2115H05	6.2	---		TA10507H15	10.8	---						
	9-13	TA7315H40	6.2	---	201-237	TA2115H05	6.0	---	238-400	TA1107H05	8.4	---	10-12	TA9415H40	8.0	---		
		TA7315H25	6.2	---		TA2115H05	6.0	---		TA9415H25	8.0	---						
		TA7315H15	6.2	---		TA2115H05	6.2	---		TA9415H15	10.3	---						
	14-18	TA6307H40	6.3	---	182-200	TA2115H05	6.2	---	238-400	TA1107H05	8.4	---	13-18	TA8407H40	6.2	---		
		TA6307H25	6.3	---		TA2115H05	6.2	---		TA8407H25	6.2	---						
		TA6307H15	6.3	---		TA2115H05	6.2	---		TA8407H15	6.2	---						
	19-32	TA5215H40	6.5	---	201-237	TA2115H05	6.0	---	238-400	TA1107H05	8.4	---	19-28	TA7315H40	6.2	---		
		TA5215H25	5.9	---		TA2115H05	6.0	---		TA7315H25	6.2	---						
		TA5215H15	6.8	---		TA2115H05	6.2	---		TA7315H15	6.2	---						
33-50	TA4207H40	4.5	---	182-200	TA2115H05	6.2	---	238-400	TA1107H05	8.4	---	29-39	TA6307H40	6.3	---			
	TA4207H25	5.0	---		TA2115H05	6.2	---		TA6307H25	6.3	---							
	TA4207H15	7.3	---		TA2115H05	6.2	---		TA6307H15	6.3	---							
51-53	TA4207H25	4.7	---	201-237	TA2115H05	6.0	---	238-400	TA1107H05	8.4	---	40-50	TA5215H40	6.2	---			
	TA4207H15	6.8	---		TA2115H05	6.0	---		TA5215H25	5.5	---							
	TA4207H15	6.8	---		TA2115H05	6.2	---		TA5215H15	6.4	---							
* See Page G1-132 for lubrication for 15 RPM and slower † See DODGE Gear Engineering Catalog DMR-1205-2 for information on TDT1425 and TDT1530 Reducer					10	46-50	TA5215H40	6.4	---	15	51-72	TA5215H25	5.4	---				
							TA5215H25	5.7	---			TA5215H15	6.3	---				
							TA5215H15	6.7	---			TA5215H15	6.3	---				
							TA4207H40	4.3	---			TA5215H40	6.2	---				
							TA4207H25	4.7	---			TA5215H25	5.5	---				
TA4207H15	7.0	---	TA4207H15	6.3	---													

FEATURES/BENEFITS PAGE G1-3	NOMENCLATURE PAGE G1-8	SELECTION/DIMENSIONS PAGE G1-36	RELATED PRODUCTS PAGE G1-123
--------------------------------	---------------------------	------------------------------------	---------------------------------



SELECTION

TORQUE-ARM II Shaft Mount Speed Reducers

CLASS III SELECTIONS (cont) * (SF = 2.0)

Motor HP	Output RPM	Reducer Selection	Min. Sheave Dia. P.D.	Cooling Method	Motor HP	Output RPM	Reducer Selection	Min. Sheave Dia. P.D.	Cooling Method	Motor HP	Output RPM	Reducer Selection	Min. Sheave Dia. P.D.	Cooling Method			
15 (cont)	73-80	TA4207H25	4.4	---	20 (cont)	39-50	TA6307H40	6.2	---	25 (cont)	50	TA6307H40	6.2	---			
		TA4207H15	6.5	---			TA6307H25	6.2	---			TA6307H25	6.2	---			
	81-89	TA4207H15	6.4	---		51-54	TA6307H15	6.2	---		51-69	TA6307H15	6.2	---	TA6307H15	6.2	---
		TA4207H09	10.1	---			TA6307H25	6.2	---			TA6307H25	6.2	---			
	90-120	TA4207H15	6.3	---		55-80	TA5215H25	5.4	---		70-80	TA5215H25	5.3	---	TA5215H25	5.3	---
		TA4207H09	9.9	---			TA5215H15	6.3	---			TA5215H15	6.1	---			
	121-125	TA4207H09	9.3	---		81-89	TA5215H15	6.0	---		81-89	TA5215H15	6.0	---	TA5215H15	6.0	---
		TA5215H05	11.8	---			TA5215H09	9.1	---			TA5215H09	9.1	---			
	126-132	TA3203H09	5.7	---		90-102	TA5215H15	5.7	---		90-93	TA5215H15	5.7	---	TA5215H15	5.7	---
		TA5215H05	11.6	---			TA5215H09	8.9	---			TA5215H09	8.9	---			
133-200	TA3203H09	5.7	---	103-107	TA5215H05	13.9	---	94-120	TA6307H05	15.1	---	TA5215H15	5.6	---			
	TA4207H05	9.2	---		TA4207H15	6.1	---		TA5215H09	8.8	---						
201-215	TA4207H05	9.3	---	108-120	TA5215H09	8.6	---	121-144	TA5215H05	13.6	---	TA5215H09	8.3	---			
	TA4207H05	9.3	---		TA5215H05	12.9	---		TA5215H05	11.8	---						
216-400	TA3203H05	7.0	---	121-182	TA4207H15	6.0	---	145-200	TA5215H09	8.3	---	TA4207H09	8.9	---			
					TA4207H09	9.5	---		TA5215H05	11.2	---						
20	4	TDT1530 †	15.0	---	183-200	TA4207H09	9.3	---	201-242	TA5215H05	9.9	---	TA5215H05	9.9	---		
	5-6	TDT1425 †	15.0	---		TA5215H05	11.8	---		TA4207H05	9.7	---					
	7	TA12608H40	17.2	---	201-324	TA4207H09	8.1	---	243-400	TDT1530 †	15.0	---	TA12608H40	17.2	---		
		TDT1425 †	15.0	---		TA4207H05	9.2	---		TDT1425 †	15.0	---					
	8	TA12608H40	17.2	---	325-400	TA4207H05	9.8	---	11-13	TA12608H40	17.2	---	TA12608H25	9.5	---		
		TA12608H25	9.5	---		TA3203H05	7.0	---		TA12608H15	13.9	---					
	9-12	TA12608H15	13.7	---	4-5	TDT1530 †	15.0	---	14-18	TA10507H40	8.5	---	TA10507H40	8.5	---		
		TA10507H40	8.5	---		6-8	TDT1425 †	15.0		---	TA10507H25	8.5	---				
	13-17	TA10507H25	8.5	---	9-10	TA12608H40	17.2	---	19-26	TA10507H15	10.8	---	TA9415H40	8.0	---		
		TA10507H15	10.8	---		TA12608H25	9.5	---		TA9415H25	8.0	---					
18-25	TA9415H40	8.0	---	11-15	TA12608H15	13.7	---	27-39	TA9415H15	10.8	---	TA8407H40	6.2	---			
	TA9415H25	8.0	---		TA10507H40	8.5	---		TA8407H25	6.2	---						
26-38	TA9415H15	10.5	---	16-21	TA10507H25	8.5	---	40-50	TA8407H15	6.2	---	TA7315H40	6.2	---			
	TA8407H40	6.2	---		TA10507H15	10.8	---		TA7315H25	6.2	---						
* See Page G1-132 for lubrication for 15 RPM and slower † See DODGE Gear Engineering Catalog DMR-1205-2 for information on TDT1425 and TDT1530 Reducer					25	22-32	TA8407H40	6.2	---	30	61-80	TA6307H25	6.2	---			
							TA8407H25	6.2	---			TA6307H15	6.2	---			
							TA8407H15	6.2	---								
							TA7315H40	6.2	---								
							TA7315H25	6.2	---								
							TA7315H15	6.2	---								

FEATURES/BENEFITS PAGE G1-3	NOMENCLATURE PAGE G1-8	SELECTION/DIMENSIONS PAGE G1-36	RELATED PRODUCTS PAGE G1-123
--------------------------------	---------------------------	------------------------------------	---------------------------------

SELECTION



TORQUE-ARM II Shaft Mount Speed Reducers CLASS III SELECTIONS (cont) * (SF = 2.0)

Motor HP	Output RPM	Reducer Selection	Min. Sheave Dia. P.D.	Cooling Method	Motor HP	Output RPM	Reducer Selection	Min. Sheave Dia. P.D.	Cooling Method	Motor HP	Output RPM	Reducer Selection	Min. Sheave Dia. P.D.	Cooling Method					
30 (cont)	81-88	TA6307H15 TA6307H09	6.3 9.9	---	40 (cont)	54-80	TA7315H25 TA7315H15	6.2 6.2	---	50 (cont)	111	TA6307H15 TA6307H09	6.6 10.5	---					
	89	TA5215H15 TA6307H09	5.7 9.9	---		81-84	TA7315H15 TA7315H09	6.2 8.0	---		112-120	TA6307H15 TA6307H09 TA7315H05	6.7 10.8 13.2	---					
	90-93	TA5215H15 TA6307H09 TA6307H05	5.7 10.1 15.1	---		85-89	TA6307H15 TA6307H09	6.3 9.9	---		121-157	TA6307H09 TA7315H05	10.9 12.8	---					
	94-120	TA5215H15 TA5215H09 TA6307H05	5.6 8.8 15.1	---		90-112	TA6307H15 TA6307H09 TA7315H05	6.6 10.6 14.8	---		158-200	TA6307H09 TA6307H05	10.9 14.2	---					
	121-131	TA5215H09 TA6307H05	8.3 14.5	---		113-120	TA6307H15 TA6307H09 TA6307H05	6.7 10.8 14.7	---		201-400	TA6307H05	13.8	---					
	132-196	TA5215H09 TA5215H05	7.9 11.4	---		121-160	TA6307H09 TA6307H05	10.9 14.5	---		7-14	TDT1530 †	15.0	---					
	197-200	TA4207H09 TA5215H05	7.8 10.0	---		161-200	TA5215H09 TA6307H05	6.8 14.1	---		15-20	TDT1425 †	15.0	---					
	201-344	TA5215H05	9.9	---		201-246	TA6307H05	13.8	---		21	TA12608H40 TDT1425 †	17.1 15.0	---					
	345-400	TA4207H05	8.2	---		247-400	TA5215H05	9.0	---		22-27	TA12608H40 TA12608H25 TA12608H15	17.1 9.5 14.8	---					
	40	5-9	TDT1530 †	15.0		---	50	6-11	TDT1530 †		15.0	---	60	28	TA10507H40 TA12608H25 TA12608H15	8.5 9.5 14.9	---		
		10-13	TDT1425 †	15.0		---		12-17	TDT1425 †		15.0	---		29-38	TA10507H40 TA10507H25 TA10507H15	8.5 8.5 10.7	---		
		14	TA12608H40 TDT1425 †	17.1 15.0		---		18-22	TA12608H40 TA12608H25 TA12608H15		17.1 9.5 14.6	---		39-45	TA9415H40 TA9415H25 TA9415H15	8.0 8.0 10.8	Fan ---		
15-17		TA12608H40 TA12608H25 TA12608H15	17.1 9.5 14.3	---	23-31	TA10507H40 TA10507H25 TA10507H15		8.5 8.5 10.7	---	46-50	TA9415H40 TA9415H25 TA9415H15	8.0 8.0 10.8		Fan ---					
18-25		TA10507H40 TA10507H25 TA10507H15	8.5 8.5 10.8	---	32-37	TA9415H40 TA9415H25 TA9415H15		8.0 8.0 10.8	---	51-56	TA9415H25 TA9415H15	8.0 10.8		---					
26-36		TA9415H40 TA9415H25 TA9415H15	8.0 8.0 10.8	---	38-46	TA9415H40 TA9415H25 TA9415H15		8.0 8.0 10.8	---	57-71	TA8407H25 TA8407H15	6.2 7.1		---					
37-50		TA8407H40 TA8407H25 TA8407H15	6.2 6.2 6.2	---	47-50	TA8407H40 TA8407H25 TA8407H15		6.2 6.2 6.2	Fan ---	72-80	TA8407H25 TA8407H15	6.2 7.5		Fan ---					
51-53		TA8407H25 TA8407H15	6.2 6.3	---	51-68	TA8407H25 TA8407H15		6.2 7.0	---	81-83	TA8407H15	7.7		---					
* See Page G1-132 for lubrication for 15 RPM and slower † See DODGE Gear Engineering Catalog DMR-1205-2 for information on TDT1425 and TDT1530 Reducer					69-80	TA7315H25 TA7315H15		6.2 6.2	---	84-85	TA7315H15	6.2		---					
					81-110	TA7315H15 TA7315H09		6.2 8.5	---	86-120	TA7315H15 TA7315H09	6.2 8.5		---	121-141	TA7315H09	8.6	---	
										142-150	TA6307H09	10.9		---					

FEATURES/BENEFITS PAGE G1-3	NOMENCLATURE PAGE G1-8	SELECTION/DIMENSIONS PAGE G1-36	RELATED PRODUCTS PAGE G1-123
--------------------------------	---------------------------	------------------------------------	---------------------------------



SELECTION

TORQUE-ARM II Shaft Mount Speed Reducers

CLASS III SELECTIONS (cont) * (SF = 2.0)

Motor HP	Output RPM	Reducer Selection	Min. Sheave Dia. P.D.	Cooling Method	Motor HP	Output RPM	Reducer Selection	Min. Sheave Dia. P.D.	Cooling Method	Motor HP	Output RPM	Reducer Selection	Min. Sheave Dia. P.D.	Cooling Method				
60 (cont)	151-195	TA6307H09	10.9	---	100 (cont)	48-50	TA10507H40	8.5	Fan	200 (cont)	81-98	TA12608H15	15.6	Fan				
		TA7315H05	12.1	---			TA12608H25	9.5	---			TA12608H15	15.1	P&C				
	196-200	TA6307H09	10.1	Fan		51	TA12608H25	15.7	---	250	34-57	TDT1530 †	15.0	---				
		TA7315H05	11.7	---				TA12608H15	9.6			---	66-75	TDT1425 †	15.0	P&C		
	201-208	TA7315H05	11.7	---		52-56	TA10507H25	8.5	---	300	41-57	TDT1530 †	15.0	---				
209-400	TA6307H05	13.5	---	TA10507H15				11.8	---			350	50-57	TDT1530 †	15.0	---		
75	9-17	TDT1530 †	15.0	---		57-67	TA10507H25	8.8	Fan									
		18-26	TDT1425 †	15.0				---	TA10507H15							12.4	---	
	27-34	TA12608H40	17.1	---		68	TA9415H25	8.0	Fan									
		TA12608H25	9.5	---				TA10507H15	12.5							---		
	35-36	TA12608H15	15.1	---		69-80	TA9415H25	8.0	Fan									
		TA10507H40	8.5	---				TA9415H15	10.7							Fan		
	37-49	TA12608H25	9.5	---		81-100	TA9415H15	10.5	Fan									
		TA12608H15	15.2	---				101-120	TA8407H15							8.7	Fan	
		TA10507H40	8.5	---												172-200	TA7315H09	8.4
		TA10507H25	8.5	---	331-400													TA7315H05
	TA10507H15	11.3	---	16-30		TDT1530 †	15.0											
	50	TA9415H40	8.0				Fan	31-43	TDT1425 †									
		TA9415H25	8.0	Fan		44-50	TA12608H40									17.1	Fan	
	TA9415H15	10.8	---	TA12608H25	9.5			---										
	51-72	TA9415H25	8.0		Fan	TA12608H15	15.7	---										
		TA9415H15	10.8	---	51-58		TA12608H25	9.6	---									
	73-80	TA8407H25	6.2	Fan		TA12608H15		15.9	---									
		TA8407H15	7.5	---	59-67		TA12608H25	10.4	Fan									
	81-112	TA8407H15	8.6	---		TA12608H15		16.1	---									
		113	TA7315H15	6.2	---		68-80	TA10507H25	9.4							Fan		
114-120	TA7315H15	6.2	---	TA10507H15	13.4	Fan												
	TA7315H09	8.5	---		81-90	TA10507H15	13.6	Fan										
121-156	TA7315H09	8.6	---	91-120			TA9415H15	10.3	Fan									
157-200	TA7315H09	8.5	Fan		19-36	TDT1530 †		15.0	---									
213-306	TA7315H05	11.5	---	37-41			TDT1425 †	15.0	---									
307-400	TA6307H05	11.7	---		42-52	TDT1425 †		15.0	Fan									
100	12-23	TDT1530 †	15.0	---			150	53-80	TA12608H25	10.7	Fan							
		24-35	TDT1425 †	15.0	---	TA12608H15			16.1	Fan								
	36-47	TA12608H40	17.1	---	81-83	TA12608H15		15.6	Fan									
		TA12608H25	9.5	---				84-115	TA10507H15	13.6	Fan							
	TA12608H15	15.6	---	116-120	TA9415H15	10.2				Fan								
* See Page G1-132 for lubrication for 15 RPM and slower † See DODGE Gear Engineering Catalog DMR-1205-2 for information on TDT1425 and TDT1530 Reducer						200	27-50	TDT1530 †	15.0	---								
					51-70		TDT1425 †	15.0	P&C									
					71-80		TA12608H25	10.7	P&C									
							TA12608H15	16.1	Fan									

FEATURES/BENEFITS PAGE G1-3	NOMENCLATURE PAGE G1-8	SELECTION/DIMENSIONS PAGE G1-36	RELATED PRODUCTS PAGE G1-123
--------------------------------	---------------------------	------------------------------------	---------------------------------



TORQUE-ARM II Shaft Mount Speed Reducers

SELECTION GUIDE: TA II TORQUE-ARM SHAFT MOUNT REDUCERS AND SCREW CONVEYOR DRIVES

This is a reference sheet for quick selection and specification of DODGE TA II Shaft Mount Reducers. Use it to identify information needed to make an accurate selection with a step-by-step selection format for choosing a reducer, accessories and belt drive.

Name		Company Name		
Phone Number		Fax. No.	e-mail Address:	
Application Data:				
Driven Equipment:				
Type		RPM	Shaft Size	
Hours of service/day			Class of Service	
Type of Load:		Uniform	Moderate	Shock
Screw Conveyor applications:				
Screw Diameter		Drive shaft diameter		
Motor:	HP	RPM	Frame Size	Shaft Size
Type of reducer mounting:		Horizontal	Vertical - input up	
Vertical - input down		Incline (degree of)	Flange Mounting	
Unusual ambient temperature:				
Other important application characteristics (reversing duty, start/stop cycles, etc.):				
Reducer Drive Selection:				
Step 1 - Determine class of service				
Step 2 - From Class of Service Table, select reducer type, size and ratio that meets Application HP and Driven RPM requirements:				
Twin Taper Bushed		Screw Conveyor		
Step 3 - Select reducer accessories required for application:				
Twin Taper Bushing Kit:		Standard Shaft	Short Shaft	
Rod Assembly		Backstop	Cooling Fan	
Motor Mount		Belt Guard	Adapter & Hardware Kit	
Adjustable Packing Kit		Drive Shaft	Stainless Drive Shaft	
Other				
Belt Drive Specification:				
Service Factor	Belt Type	Center Distance	Sheave Ratio	
Driver: Shaft Diameter	Sheave	Bushing	Belt Size & Qty	
Driven: Shaft diameter	Sheave	Bushing	Belt Size & Qty	

FEATURES/BENEFITS PAGE G1-3	NOMENCLATURE PAGE G1-8	SELECTION/DIMENSIONS PAGE G1-36	RELATED PRODUCTS PAGE G1-123
--------------------------------	---------------------------	------------------------------------	---------------------------------

SELECTION/DIMENSIONS



TORQUE-ARM II Shaft Mount Speed Reducers TAPER BUSHED REDUCERS - TA0107L, SINGLE AND DOUBLE REDUCTION

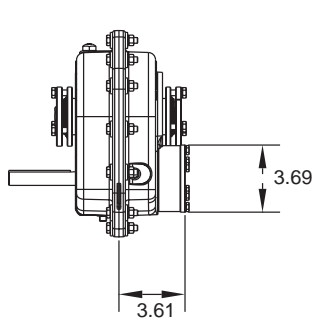
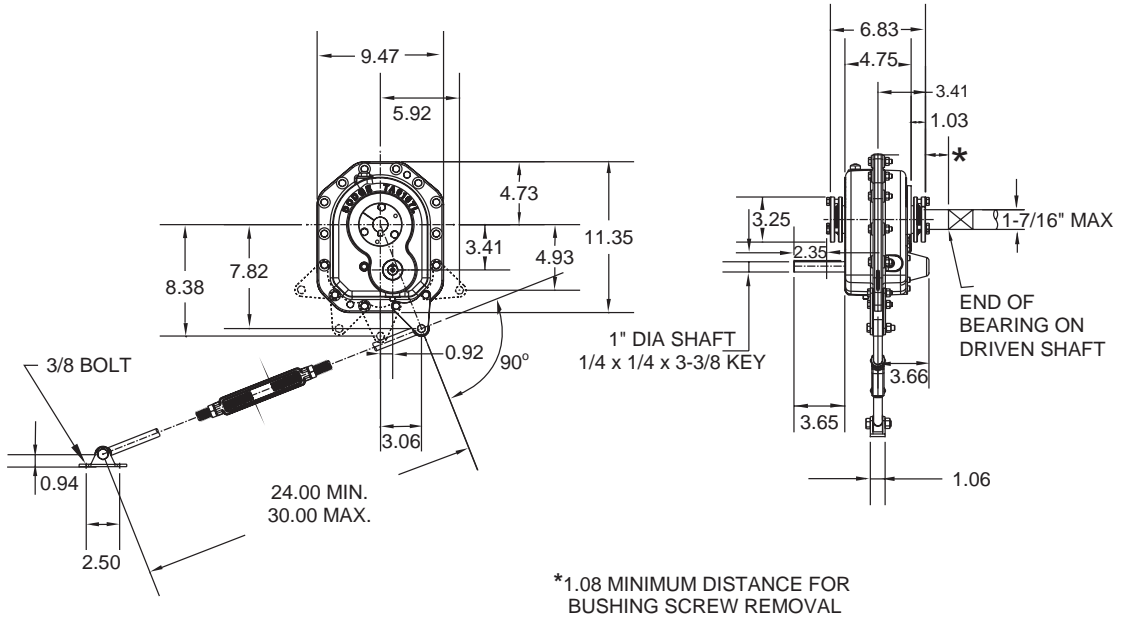

REDUCER WITH BACKSTOP

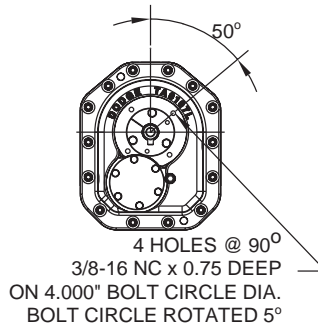

FLANGE MOUNTING DIMENSIONS

FEATURES/BENEFITS PAGE G1-3	NOMENCLATURE PAGE G1-8	SELECTION PAGE G1-12	RELATED PRODUCTS PAGE G1-123
--------------------------------	---------------------------	-------------------------	---------------------------------



TORQUE-ARM II Shaft Mount Speed Reducers TAPER BUSHED REDUCERS - TA0107L, SINGLE AND DOUBLE REDUCTION

TA0107L Taper Bushed Reducers ⁽¹⁾ ●

Reducer Size	Part Number	AGMA Code	Actual Ratio	Weight lbs.
TA0107L05	900004	107S05	5.20	39.6
TA0107L09	900003	107D09	9.00	41.2
TA0107L15	900002	107D15	14.93	41.1
TA0107L25	900001	107D25	25.09	41.0
TA0107L31	900000	107D31	30.94	41.2

(1) Reducers are supplied from stock ready for vertical mounting and for flange mounting. Rod assembly is not included with reducer. Order as a separate part number.

- TA0107L Reducer = Light duty, best value

TA0107L Accessories

Description	Part Number	Weight lbs.
TA0107RA Rod Assembly ⁽¹⁾	900109	4.5
TA1107/0107L BS Backstop Assembly ⁽²⁾	901102	3.9
TA0107MM Motor Mount Assembly (56-215T) ⁽³⁾	900090	35.4
TA0107BG Belt Guard - Pos. B (56-215T)	900096	40.6
TA0107BG Belt Guard - Pos. C (56-215T) ⁽⁴⁾	900097	42.2
TA0-TA3 Vertical Breather Kit	900112	2.0
Filter Breather Plug	430048	0.2

- (2) See page G1-129 for input shaft speed necessary for backstop sprag lift-off.
- (3) Motor Mount will fit NEMA and IEC frame motors; however hardware are inch dimensions.
- (4) Use Position-C belt guard for TA II reducer in screw conveyor drive applications.

TA0107L Tapered Bushing Kits ⁽⁵⁾ (6)

Bushing Size Standard Shaft Bushing Kit	Part Number (7)	Weight lbs.	Shaft Keyseat Required (9) (10)	Bushing Size	Part Number	Weight lbs.	Shaft Keyseat Required (9) (10)
				Short Shaft Bushing Kit (8)			
TA0107TB x 1-7/16 ▲	900020	1.5	3/8 x 3/16 x 6.83	---	---	---	---
TA0107TB x 1-3/8	900021	1.6	5/16 x 5/32 x 6.83	---	---	---	---
TA0107TB x 1-5/16	900022	1.8	5/16 x 5/32 x 6.83	---	---	---	---
TA0107TB x 1-1/4	900023	1.9	1/4 x 1/8 x 6.83	---	---	---	---
TA0107TB x 1-3/16	900024	2.0	1/4 x 1/8 x 6.83	TA0107TBS x 1-3/16	900027	2.1	1/4 x 1/8 x 4.35
TA0107TB x 1-1/8	900025	2.1	1/4 x 1/8 x 6.83	TA0107TBS x 1-1/8	900028	2.3	1/4 x 1/8 x 4.35
TA0107TB x 1	900026	2.4	1/4 x 1/8 x 6.83	TA0107TBS x 1	900029	2.6	1/4 x 1/8 x 4.35

▲ AGMA maximum bore size

- (5) Bushing kit required to mount TA II reducer to driven shaft
- (6) Bushing kit is not required to mount TA II reducer on SCS Drive Shaft in a screw conveyor application
- (7) Standard Shaft Bushing Kit includes two standard bushings with back-up plates and snap rings; hardware, and key
- (8) Short Shaft Bushing Kit includes one standard bushing, one long bushing with insertable wedge; two back-up plates with snap rings; hardware and key. This is an optional bushing for after market, short shaft mounting.
- (9) Minimum keyseat and shaft length required to mount reducer with bushing kit
- (10) Always check the driven shaft and key for strength

FEATURES/BENEFITS PAGE G1-3	NOMENCLATURE PAGE G1-8	SELECTION PAGE G1-12	RELATED PRODUCTS PAGE G1-123
--------------------------------	---------------------------	-------------------------	---------------------------------

SELECTION/DIMENSIONS



TORQUE-ARM II Shaft Mount Speed Reducers SCREW CONVEYOR DRIVE - TA0107L, SINGLE AND DOUBLE REDUCTION

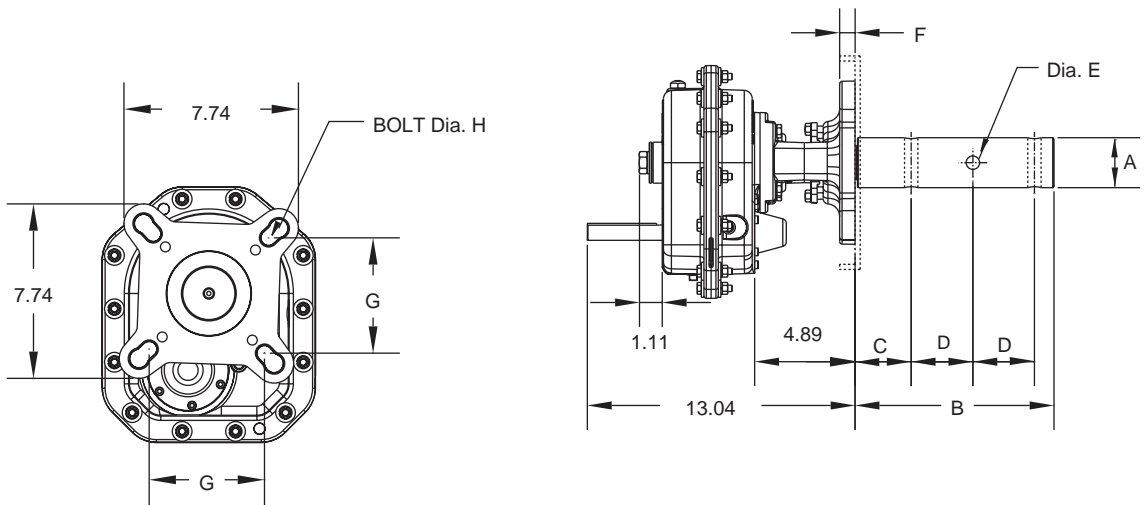

FEATURES/BENEFITS PAGE G1-3	NOMENCLATURE PAGE G1-8	SELECTION PAGE G1-12	RELATED PRODUCTS PAGE G1-123
--------------------------------	---------------------------	-------------------------	---------------------------------

SELECTION/DIMENSIONS



TORQUE-ARM II Shaft Mount Speed Reducers SCREW CONVEYOR DRIVE - TA0107L, SINGLE AND DOUBLE REDUCTION

TA0107L Screw Conveyor Drive Dimensions

Screw Dia	Drive Shaft Dia A	Dimensions						
		B	C	D	Hole Dia E	F	G	Bolt Dia H
6, 9	1-1/2	9.00	2.13	3.00	17/32	0.75	4.00	1/2-13
9, 12	2	9.00	2.13	3.00	21/32	0.75	5.13	5/8
12, 14	2-7/16	9.69	2.75	3.00	21/32	0.75	5.63	5/8
12, 14, 16, 18, 20	3	9.88	2.88	3.00	25/32	0.75	6.00	3/4

TA0107L Accessories for Screw Conveyor Drives ⁽¹⁾ ⁽⁴⁾ ⁽⁵⁾

Description	Part Number	Weight lbs.
TA0107SCA Adapter & Hardware Kit ⁽²⁾	900070	14.7
TA0107SCP Adjustable Packing Kit ⁽³⁾	900071	0.9
TA0107SCS x 1-1/2 Drive Shaft	900072	8.8
TA0107SCS x 2 Drive Shaft	900073	12.0
TA0107SCS x 2-7/16 Drive Shaft	900074	16.5
TA0107SCS x 3 Drive Shaft	900075	22.8
TA0107SCS x 1-1/2 Stainless Steel Drive Shaft	900080	8.8
TA0107SCS x 2 Stainless Steel Drive Shaft	900081	12.0
TA0107SCS x 2-7/16 Stainless Steel Drive Shaft	900082	16.5
TA0107SCS x 3 Stainless Steel Drive Shaft	900083	22.8

- (1) See page G1-45 for Belt Guard for Screw Conveyor Drive applications
- (2) SCA Adapter & Hardware Kit includes adapter, mounting wedge, keeper plate, key, seals and hardware
- (3) SCP Adjustable Packing Kit consists of flange, mounting hardware and braided packing seals
- (4) SCS Drive Shaft is a shaft only. Hardware is stocked with the adapter & hardware kit
- (5) A complete TA II Screw Conveyor Drive includes a TA II Reducer, SCA Adapter & Hardware Kit and SCS Drive Shaft. The SCP Adjustable Packing Kit is an optional accessory.

FEATURES/BENEFITS PAGE G1-3	NOMENCLATURE PAGE G1-8	SELECTION PAGE G1-12	RELATED PRODUCTS PAGE G1-123
--------------------------------	---------------------------	-------------------------	---------------------------------



SELECTION/DIMENSIONS

TORQUE-ARM II Shaft Mount Speed Reducers MOTOR MOUNT DIMENSIONS - TA0107L, POSITION B & D

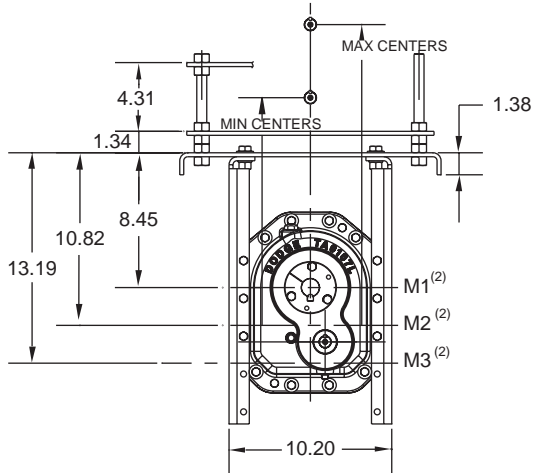

POSITION B

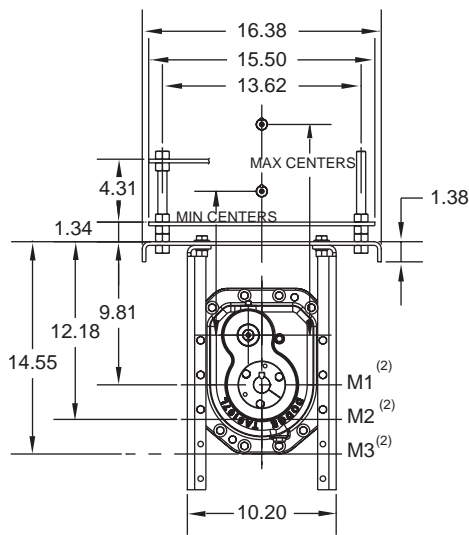
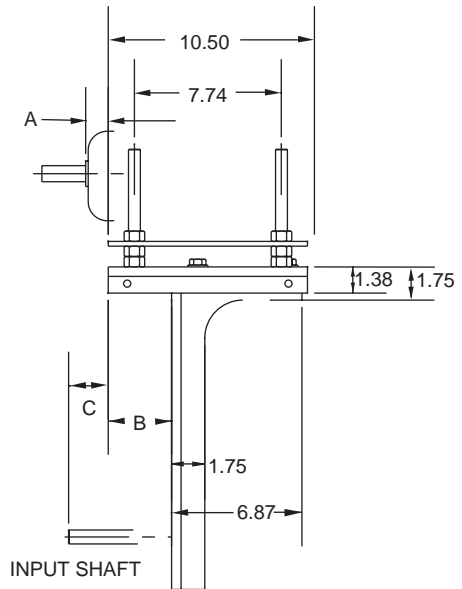

POSITION D

FEATURES/BENEFITS PAGE G1-3	NOMENCLATURE PAGE G1-8	SELECTION PAGE G1-12	RELATED PRODUCTS PAGE G1-123
--------------------------------	---------------------------	-------------------------	---------------------------------

SELECTION/DIMENSIONS



TORQUE-ARM II Shaft Mount Speed Reducers

MOTOR MOUNT DIMENSIONS - TA0107L, POSITION B & D ⁽¹⁾

Mounting	Lateral Adjustment				Motor Mount Height (2)	Motor Frame					
						56			143T & 145T		
	B Min	B Max	C Min	C Max		A	Centers		A	Centers	
							Min	Max		Min	Max
Position B	-0.09	3.33	2.10	5.52	M1	0.78	17.2	21.0	1.22	17.2	21.0
					M2		19.6	23.4		19.6	23.4
					M3		22.0	25.8		22.0	25.8
Position D	-0.09	3.33	2.10	5.52	M1	0.78	11.8	15.6	1.22	11.8	15.6
					M2		14.1	17.9		14.1	17.9
					M3		16.5	20.3		16.5	20.3

Mounting	Lateral Adjustment				Motor Mount Height (2)	Motor Frame					
						182T & 184T			213T & 215T		
	B Min	B Max	C Min	C Max		A	Centers		A	Centers	
							Min	Max		Min	Max
Position B	-0.09	3.33	2.10	5.52	M1	1.37	18.2	22.0	1.55	19.0	22.8
					M2		20.6	24.4		21.3	25.1
					M3		23.0	26.8		23.7	27.5
Position D	-0.09	3.33	2.10	5.52	M1	1.37	12.8	16.6	1.55	13.5	17.3
					M2		15.1	18.9		15.9	19.7
					M3		17.5	21.3		18.3	22.1

Note:

Minimum centers contains 0.5" to allow for belt assembly

(1) Motor mount will fit NEMA and IEC frame motors; hardware are inch dimensions

(2) M1, M2, M3 go through output shaft centerline

FEATURES/BENEFITS PAGE G1-3	NOMENCLATURE PAGE G1-8	SELECTION PAGE G1-12	RELATED PRODUCTS PAGE G1-123
--------------------------------	---------------------------	-------------------------	---------------------------------



SELECTION/DIMENSIONS

TORQUE-ARM II Shaft Mount Speed Reducers MOTOR MOUNT DIMENSIONS - TA0107L, POSITION A & C

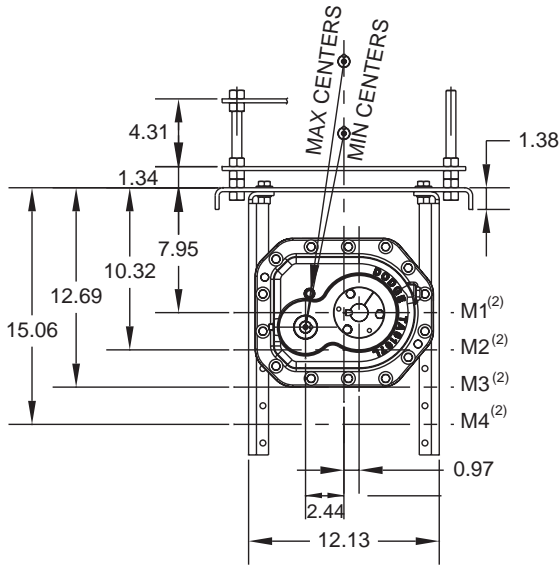

POSITION A

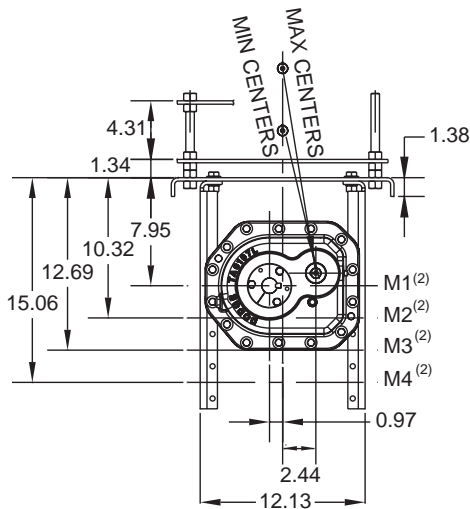

POSITION C

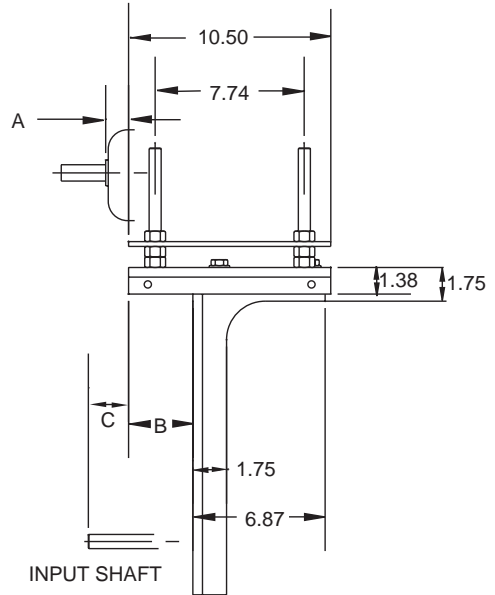

FEATURES/BENEFITS PAGE G1-3	NOMENCLATURE PAGE G1-8	SELECTION PAGE G1-12	RELATED PRODUCTS PAGE G1-123
--------------------------------	---------------------------	-------------------------	---------------------------------

SELECTION/DIMENSIONS



TORQUE-ARM II Shaft Mount Speed Reducers

MOTOR MOUNT DIMENSIONS - TA0107L, POSITION A & C (1) (3)

Mounting	Lateral Adjustment				Motor Mount Height (2)	Motor Frame					
						56			143T & 145T		
	B Min	B Max	C Min	C Max		A	Centers		A	Centers	
Min					Max		Min	Max			
Position A	-0.09	3.33	3.05	6.47	M1	0.78	14.4	18.2	1.22	14.4	18.2
					M2		16.8	20.5		16.8	20.5
					M3		19.1	22.9		19.1	22.9
					M4		21.5	25.2		21.5	25.2
Position C	-0.09	3.33	3.05	6.47	M1	0.78	12.6	16.4	1.22	12.6	16.4
					M2		14.9	18.7		14.9	18.7
					M3		17.3	21.1		17.3	21.1
					M4		19.6	23.4		19.6	23.4

Mounting	Lateral Adjustment				Motor Mount Height (2)	Motor Frame					
						182T & 184T			213T & 215T		
	B Min	B Max	C Min	C Max		A	Centers		A	Centers	
Min					Max		Min	Max			
Position A	-0.09	3.33	3.05	6.47	M1	1.37	15.4	19.2	1.55	16.2	19.9
					M2		17.8	21.5		18.5	22.3
					M3		20.1	23.9		20.8	24.6
					M4		22.5	26.2		23.2	27.0
Position C	-0.09	3.33	3.05	6.47	M1	1.37	13.6	17.4	1.55	14.3	18.1
					M2		15.9	19.7		16.7	20.4
					M3		18.3	22.1		19.0	22.8
					M4		20.6	24.4		21.4	25.2

Note:

Minimum centers contain 0.5" to allow for belt assembly

(1) Motor mount will fit NEMA and IEC frame motors; hardware are inch dimensions

(2) M1, M2, M3, M4 go through output shaft centerline

(3) See Table A, below, for minimum "M" mounting position required for specific screw diameter and reducer size

Table A - Screw Conveyor Motor Mount Minimum "M" Mounting Positions (1)

Nominal Screw Dia	Trough Height Dim	Minimum Mounting Position							
		TA0107L	TA1107H	TA2115H	TA3203H	TA4207H	TA5215H	TA6307H	TA7315H
6	7.00	M2	M3	M2	M2	M2	M1	M1	M1
9	9.00	M3	M4	M3	M3	M2	M2	M2	M1
12	10.00	M4	M4	M3	M3	M2	M2	M2	M1
14	11.00	M4	M4	M4	M3	M3	M2	M2	M2
16	11.50	M4	***	M4	M4	M3	M2	M2	M2
18	12.13	***	***	M4	M4	M3	M3	M2	M2
20	13.50	***	***	M4	M4	M3	M3	M3	M2
24	16.50	***	***	***	***	M4	M3	M3	M3

(1) For U Or Flared Trough Ends Per CEMA 300-014

FEATURES/BENEFITS PAGE G1-3	NOMENCLATURE PAGE G1-8	SELECTION PAGE G1-12	RELATED PRODUCTS PAGE G1-123
--------------------------------	---------------------------	-------------------------	---------------------------------



SELECTION/DIMENSIONS

TORQUE-ARM II Shaft Mount Speed Reducers TAPER BUSHED REDUCERS - TA1107H, SINGLE AND DOUBLE REDUCTION

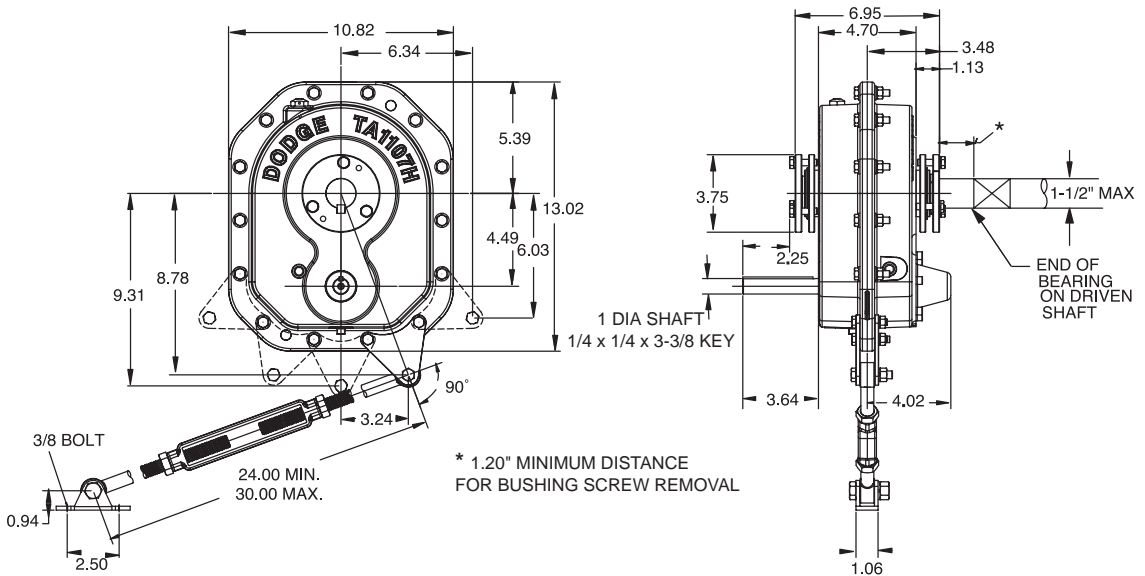

REDUCER WITH BACKSTOP

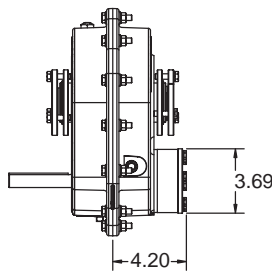

FLANGE MOUNTING DIMENSIONS

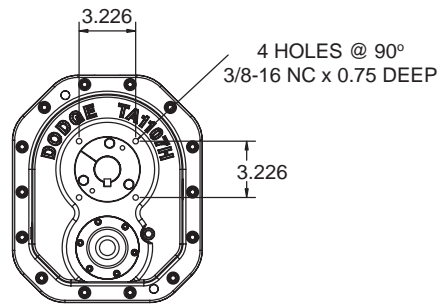

FEATURES/BENEFITS PAGE G1-3	NOMENCLATURE PAGE G1-8	SELECTION PAGE G1-12	RELATED PRODUCTS PAGE G1-123
--------------------------------	---------------------------	-------------------------	---------------------------------



TORQUE-ARM II Shaft Mount Speed Reducers TAPER BUSHED REDUCERS - TA1107H, SINGLE AND DOUBLE REDUCTION

TA1107H Taper Bushed Reducers ⁽¹⁾ ● ■

Reducer Size	Part Number	AGMA Code	Actual Ratio	Weight lbs.
TA1107H05	901004	107S05	5.00	55.4
TA1107H09	901003	107D09	8.99	56.8
TA1107H15	901002	107D15	14.91	56.7
TA1107H25	901001	107D25	25.06	56.7
TA1107H31	901000	107D31	30.91	56.8

- (1) Reducers are supplied from stock ready for vertical mounting and for flange mounting. Rod assembly is not included with reducer. Order as a separate part number.
- TA1107H Reducer - Heavy duty, extended value
 - See page G1-124 for Maximum Bore Straight Bore TA II Reducers

TA1107H Accessories

Description	Part Number	Weight lbs.
TA1107RA Rod Assembly ⁽¹⁾	901109	4.5
TA1107H/0107L BS Backstop Assembly ⁽²⁾	901102	3.9
TA1107MM Motor Mount Assembly (56-254T) ⁽³⁾	901090	39.5
TA1107BG Belt Guard - Pos. B (56-254T)	901096	40.6
TA1107BG Belt Guard - Pos. C (56-254T) ⁽⁴⁾	901097	43.1
TA0-TA3 - Vertical Breather Kit	900112	2.0
Filter Breather Plug	430048	0.2

- (2) See page G1-130 for input shaft speed necessary for backstop sprag lift-off
- (3) Motor Mount will fit NEMA and IEC frame motors; however hardware are inch dimensions
- (4) Use Position-C belt guard for TA II reducer in screw conveyor drive applications

TA1107H Tapered Bushing Kits ⁽⁵⁾ (6)

Bushing Size Standard Shaft Bushing Kit	Part Number (7)	Weight lbs.	Shaft Keyseat Required (9) (10)	Bushing Size	Part Number	Weight lbs.	Shaft Keyseat Required (9) (10)
				Short Shaft Bushing Kit (8)			
TA1107TB x 1-1/2	901020	3.3	3/8 x 3/16 x 6.95	---	---	---	---
TA1107TB x 1-7/16 ▲	901021	3.6	3/8 x 3/16 x 6.95	TA1107TBS x 1-7/16	901030	3.7	3/8 x 3/16 x 4.43
TA1107TB x 1-3/8	901022	3.5	5/16 x 5/32 x 6.95	TA1107TBS x 1-3/8	901031	3.8	5/16 x 5/32 x 4.43
TA1107TB x 1-5/16	901023	3.8	5/16 x 5/32 x 6.95	TA1107TBS x 1-5/16	901032	4	5/16 x 5/32 x 4.43
TA1107TB x 1-1/4	901024	3.7	1/4 x 1/8 x 6.95	TA1107TBS x 1-1/4	901033	4.1	1/4 x 1/8 x 4.43
TA1107TB x 1-3/16	901025	3.8	1/4 x 1/8 x 6.95	TA1107TBS x 1-3/16	901034	4.2	1/4 x 1/8 x 4.43
TA1107TB x 1-1/8	901026	4.0	1/4 x 1/8 x 6.95	TA1107TBS x 1-1/8	901035	4.4	1/4 x 1/8 x 4.43
TA1107TB x 1-1/16	901027	4.0	1/4 x 1/8 x 6.95	TA1107TBS x 1-1/16	901036	4.5	1/4 x 1/8 x 4.43
TA1107TB x 1	901028	4.2	1/4 x 1/8 x 6.95	TA1107TBS x 1	901037	4.7	1/4 x 1/8 x 4.43

- ▲ AGMA maximum bore size
- (5) Bushing kit required to mount TA II reducer to driven shaft
- (6) Bushing kit is not required to mount TA II reducer on SCS Drive Shaft in a screw conveyor application
- (7) Standard Shaft Bushing Kit includes two standard bushings with back-up plates and snap rings; hardware, and key
- (8) Short Shaft Bushing Kit includes one standard bushing, one long bushing with insertable wedge; two back-up plates with snap rings; hardware and key. This is an optional bushing for after market, short shaft mounting.
- (9) Minimum keyseat and shaft length required to mount reducer with bushing kit
- (10) Always check the driven shaft and key for strength

FEATURES/BENEFITS PAGE G1-3	NOMENCLATURE PAGE G1-8	SELECTION PAGE G1-12	RELATED PRODUCTS PAGE G1-123
--------------------------------	---------------------------	-------------------------	---------------------------------

SELECTION/DIMENSIONS



TORQUE-ARM II Shaft Mount Speed Reducers SCREW CONVEYOR DRIVE - TA1107H, SINGLE AND DOUBLE REDUCTION

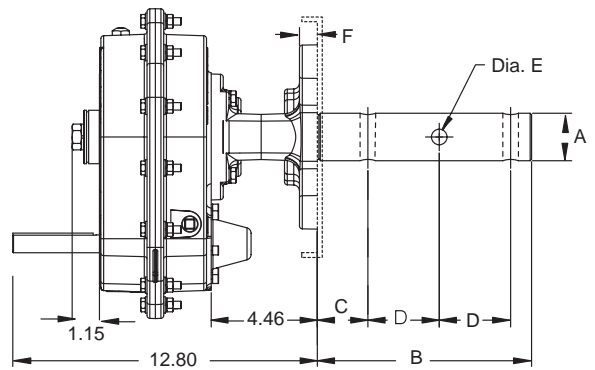
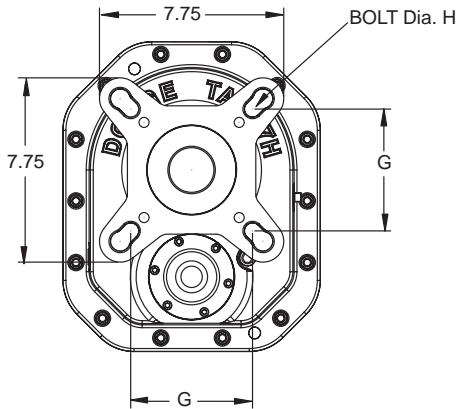

FEATURES/BENEFITS PAGE G1-3	NOMENCLATURE PAGE G1-8	SELECTION PAGE G1-12	RELATED PRODUCTS PAGE G1-123
--------------------------------	---------------------------	-------------------------	---------------------------------

SELECTION/DIMENSIONS



TORQUE-ARM II Shaft Mount Speed Reducers SCREW CONVEYOR DRIVE - TA1107H, SINGLE AND DOUBLE REDUCTION

TA1107H Screw Conveyor Drive Dimensions

Screw Dia	Drive Shft Dia A	Dimensions						
		B	C	D	Hole Dia E	F	G	Bolt Dia H
6, 9	1-1/2	9.00	2.13	3.00	17/32	0.75	4.00	1/2-13
9, 12	2	9.00	2.13	3.00	21/32	0.75	5.13	5/8
12, 14	2-7/16	9.69	2.75	3.00	21/32	0.75	5.63	5/8
12, 14, 16, 18, 20	3	9.88	2.88	3.00	25/32	0.75	6.00	3/4

TA1107H Accessories for Screw Conveyor Drives (1) (4) (5)

Description	Part Number	Weight lbs.
TA1107SCA Adapter & Hardware Kit (2)	901070	15.2
TA1107SCP Adjustable Packing Kit (3)	901071	0.8
TA1107SCS x 1-1/2 Drive Shaft	901072	10.3
TA1107SCS x 2 Drive Shaft	901073	13.5
TA1107SCS x 2-7/16 Drive Shaft	901074	18.1
TA1107SCS x 3 Drive Shaft	901075	24.4
TA1107SCS x 1-1/2 Stainless Steel Drive Shaft	901080	10.3
TA1107SCS x 2 Stainless Steel Drive Shaft	901081	13.5
TA1107SCS x 2-7/16 Stainless Steel Drive Shaft	901082	18.1
TA1107SCS x 3 Stainless Steel Drive Shaft	901083	24.4

- (1) See page G1-45 for Belt Guard for Screw Conveyor Drive applications
- (2) SCA Adapter & Hardware Kit includes adapter, mounting wedge, keeper plate, key, seals and hardware
- (3) SCP Adjustable Packing Kit consists of flange, mounting hardware and braided packing seals
- (4) SCS Drive Shaft is a shaft only. Hardware is stocked with the adapter & hardware kit
- (5) A complete TA II Screw Conveyor Drive includes a TA II Reducer, SCA Adapter & Hardware Kit, and SCS Drive Shaft. The SCP Adjustable Packing Kit is an optional accessory.

FEATURES/BENEFITS PAGE G1-3	NOMENCLATURE PAGE G1-8	SELECTION PAGE G1-12	RELATED PRODUCTS PAGE G1-123
--------------------------------	---------------------------	-------------------------	---------------------------------

SELECTION/DIMENSIONS



TORQUE-ARM II Shaft Mount Speed Reducers MOTOR MOUNT DIMENSIONS - TA1107H, POSITION B & D

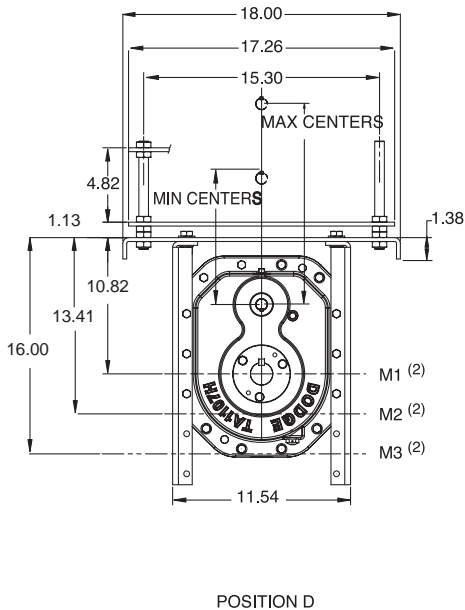
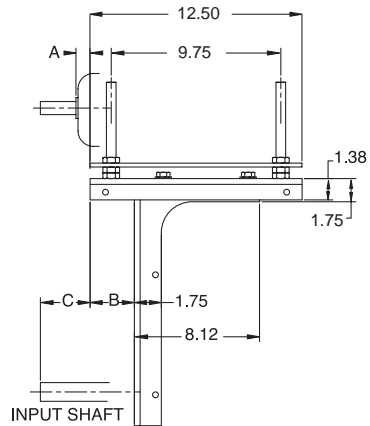
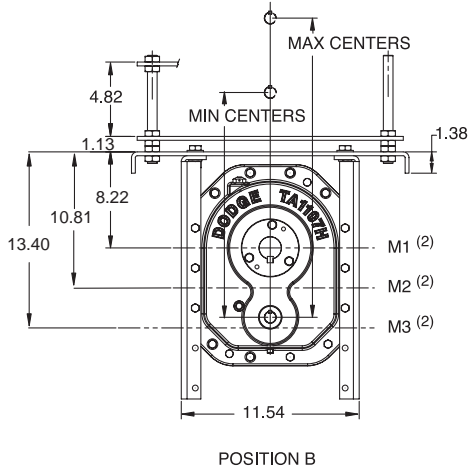

FEATURES/BENEFITS PAGE G1-3	NOMENCLATURE PAGE G1-8	SELECTION PAGE G1-12	RELATED PRODUCTS PAGE G1-123
--------------------------------	---------------------------	-------------------------	---------------------------------

SELECTION/DIMENSIONS



TORQUE-ARM II Shaft Mount Speed Reducers

MOTOR MOUNT DIMENSIONS - TA1107H, POSITION B & D ⁽¹⁾

Mounting	Lateral Adjustment				Motor Mount Height (2)	Motor Frame					
						56			143T & 145T		
	B Min	B Max	C Min	C Max		A	Centers		A	Centers	
							Min	Max		Min	Max
Position B	-0.09	3.33	2.06	5.48	M1	0.78	17.7	22.0	1.22	17.7	22.0
					M2		20.3	24.6		20.3	24.6
					M3		22.9	27.2		22.9	27.2
Position D	-0.09	3.33	2.06	5.48	M1	0.78	11.3	15.7	1.22	11.3	15.7
					M2		13.9	18.2		13.9	18.2
					M3		16.5	20.8		16.5	20.8

Mounting	Motor Mount Height (2)	Motor Frame								
		182T & 184T			213T & 215T			254T		
		A	Centers		A	Centers		A	Centers	
			Min	Max		Min	Max		Min	Max
Position B	M1	1.37	18.7	23.0	1.55	19.5	23.8	1.56	20.5	24.8
	M2		21.3	25.6		22.1	26.4		23.1	27.4
	M3		23.9	28.2		24.6	29.0		25.6	30.0
Position D	M1	1.37	12.3	16.7	1.55	13.1	17.4	1.56	14.1	18.4
	M2		14.9	19.2		15.7	20.0		16.7	21.0
	M3		17.5	21.8		18.3	22.6		19.3	23.6

Note:

Minimum centers contains 0.5" to allow for belt assembly

(1) Motor mount will fit NEMA and IEC frame motors; hardware are inch dimensions

(2) M1, M2, M3 go through output shaft centerline

FEATURES/BENEFITS PAGE G1-3	NOMENCLATURE PAGE G1-8	SELECTION PAGE G1-12	RELATED PRODUCTS PAGE G1-123
--------------------------------	---------------------------	-------------------------	---------------------------------



SELECTION/DIMENSIONS

TORQUE-ARM II Shaft Mount Speed Reducers MOTOR MOUNT DIMENSIONS - TA1107H, POSITION A & C

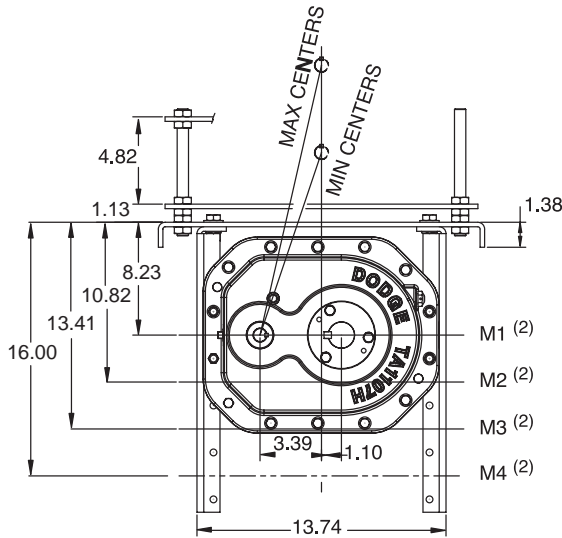

POSITION A

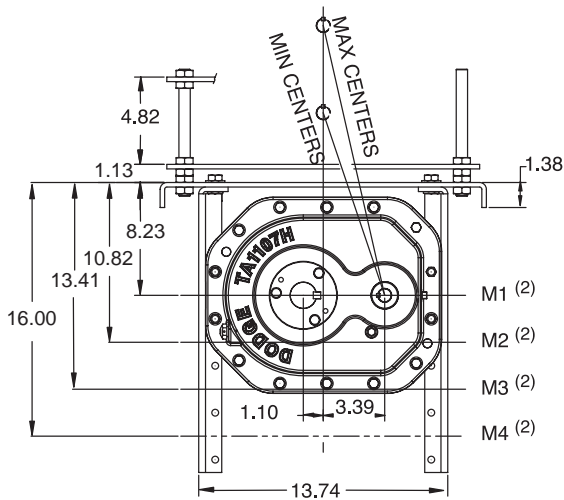

POSITION C

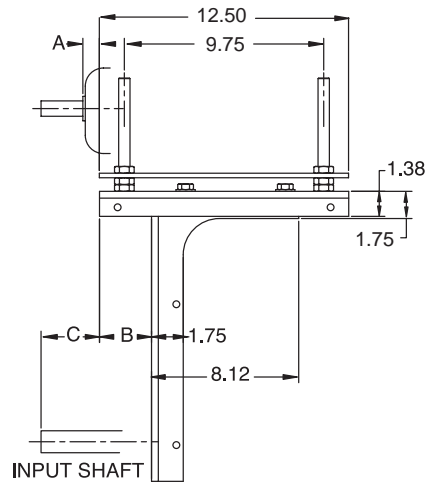

FEATURES/BENEFITS PAGE G1-3	NOMENCLATURE PAGE G1-8	SELECTION PAGE G1-12	RELATED PRODUCTS PAGE G1-123
--------------------------------	---------------------------	-------------------------	---------------------------------

SELECTION/DIMENSIONS



TORQUE-ARM II Shaft Mount Speed Reducers

MOTOR MOUNT DIMENSIONS - TA1107H, POSITION A & C (1) (3)

Mounting	Lateral Adjustment				Motor Mount Height (2)	Motor Frame					
						56			143T & 145T		
	B Min	B Max	C Min	C Max		A	Centers		A	Centers	
Min					Max		Min	Max			
Position A	-0.09	3.33	3.01	6.43	M1	0.78	13.8	17.9	1.22	13.8	17.9
					M2		16.2	20.5		16.2	20.5
					M3		18.8	23.0		18.8	23.0
					M4		21.3	25.6		21.3	25.6
Position C	-0.09	3.33	3.01	6.43	M1	0.78	13.8	17.9	1.22	13.8	17.9
					M2		16.2	20.5		16.2	20.5
					M3		18.8	23.0		18.8	23.0
					M4		21.3	25.6		21.3	25.6

Mounting	Motor Mount Height (2)	Motor Frame								
		182T & 184T			213T & 215T			254T		
		A	Centers		A	Centers		A	Centers	
Min	Max		Min	Max		Min	Max			
Position A	M1	1.37	14.7	18.9	1.55	15.4	19.6	1.56	16.4	20.6
	M2		17.2	21.4		17.9	22.2		18.9	23.2
	M3		19.7	24.0		20.5	24.7		21.5	25.7
	M4		22.3	26.6		23.0	27.3		24.0	28.3
Position C	M1	1.37	14.7	18.9	1.55	15.4	19.6	1.56	16.4	20.6
	M2		17.2	21.4		17.9	22.2		18.9	23.2
	M3		19.7	24.0		20.5	24.7		21.5	25.7
	M4		22.3	26.6		23.0	27.3		24.0	28.3

Note:

Minimum centers contains 0.5" to allow for belt assembly

(1) Motor mount will fit NEMA and IEC frame motors; hardware are inch dimensions

(2) M1, M2, M3, M4 go through output shaft centerline

(3) See Table A, below, for minimum "M" mounting position required for specific screw diameter and reducer size

Table A - Screw Conveyor Motor Mount Minimum "M" Mounting Positions (1)

Nominal Screw Dia	Trough Height Dim	Minimum Mounting Position							
		TA0107L	TA1107H	TA2115H	TA3203H	TA4207H	TA5215H	TA6307H	TA7315H
6	7.00	M2	M3	M2	M2	M2	M1	M1	M1
9	9.00	M3	M4	M3	M3	M2	M2	M2	M1
12	10.00	M4	M4	M3	M3	M2	M2	M2	M1
14	11.00	M4	M4	M4	M3	M3	M2	M2	M2
16	11.50	M4	***	M4	M4	M3	M2	M2	M2
18	12.13	***	***	M4	M4	M3	M3	M2	M2
20	13.50	***	***	M4	M4	M3	M3	M3	M2
24	16.50	***	***	***	***	M4	M3	M3	M3

(1) For U Or Flared Trough Ends Per CEMA 300-014

FEATURES/BENEFITS PAGE G1-3	NOMENCLATURE PAGE G1-8	SELECTION PAGE G1-12	RELATED PRODUCTS PAGE G1-123
--------------------------------	---------------------------	-------------------------	---------------------------------



SELECTION/DIMENSIONS

TORQUE-ARM II Shaft Mount Speed Reducers TAPER BUSHED REDUCER - TA2115H, SINGLE AND DOUBLE REDUCTION

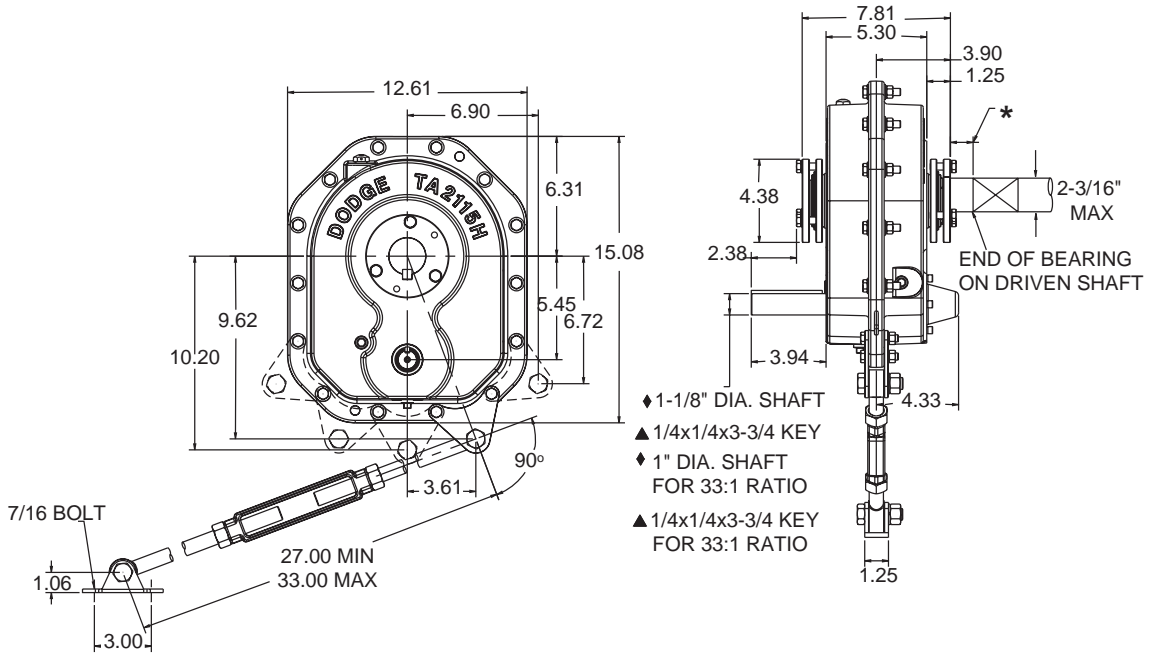

* 1.20" MINIMUM DISTANCE FOR BUSHING SCREW REMOVAL

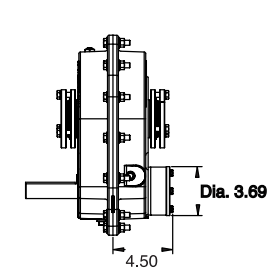

REDUCER WITH BACKSTOP

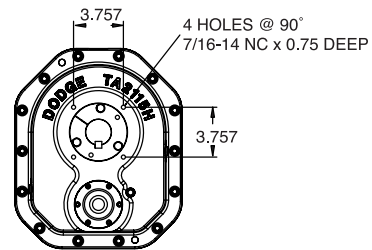

FLANGE MOUNTING DIMENSIONS

FEATURES/BENEFITS PAGE G1-3	NOMENCLATURE PAGE G1-8	SELECTION PAGE G1-12	RELATED PRODUCTS PAGE G1-123
--------------------------------	---------------------------	-------------------------	---------------------------------



TORQUE-ARM II Shaft Mount Speed Reducers TAPER BUSHED REDUCER - TA2115H, SINGLE AND DOUBLE REDUCTION

TA2115H Taper Bushed Reducers ⁽¹⁾

Reducer Size	Part Number	AGMA Code	Actual Ratio	Weight lbs.
TA2115H05	902004	115S05	5.20	84.2
TA2115H09	902003	115D09	9.10	86.5
TA2115H15	902002	115D15	15.62	86.3
TA2115H25	902001	115D25	25.07	86.1
TA2115H33	902000	115D33	33.33	85.7

- (1) Reducers are supplied from stock ready for vertical mounting and for flange mounting. Rod assembly is not included with reducer. Order as a separate part number.

TA2115H Accessories

Description	Part Number	Weight lbs.
TA2115RA Rod Assembly ⁽¹⁾	902109	6.9
TA2115BS Backstop Assembly ⁽²⁾	902102	3.9
TA2115MM Motor Mount Assembly (56-256T) ⁽³⁾	902090	52.6
TA2115BG Belt Guard - Pos. B (56-256T)	902096	47.7
TA2115BG Belt Guard - Pos. C (56-256T) ⁽⁴⁾	902097	52.1
TA0-TA3 Vertical Breather Kit	900112	2.0
Filter Breather Plug	430048	0.2

- (2) See page G1-130 for input shaft speed necessary for backstop sprag lift-off
- (3) Motor Mount will fit NEMA and IEC frame motors; however hardware are inch dimensions
- (4) Use Position-C belt guard for TA II reducer in screw conveyor drive applications

TA2115H Tapered Bushing Kits ⁽⁵⁾ ⁽⁶⁾

Bushing Size Standard Shaft Bushing Kit	Part Number (7)	Weight lbs.	Shaft Keyseat Required (9) (10)	Bushing Size	Part Number	Weight lbs.	Shaft Keyseat Required (9) (10)
				Short Shaft Bushing Kit (8)			
TA2115TB x 2-3/16	902020	4.7	1/2 x 1/4 x 7.80	---	---	---	---
TA2115TB x 2	902022	5.2	1/2 x 1/4 x 7.80	---	---	---	---
TA2115TB x 1-15/16 ▲	902023	5.4	1/2 x 1/4 x 7.80	TA2115TBS x 1-15/16	902030	5.6	1/2 x 1/4 x 4.80
TA2115TB x 1-7/8	902024	5.6	1/2 x 1/4 x 7.80	TA2115TBS x 1-7/8	902031	5.9	1/2 x 1/4 x 4.80
TA2115TB x 1-3/4	902025	5.8	3/8 x 3/16 x 7.80	TA2115TBS x 1-3/4	902032	6	3/8 x 3/16 x 4.80
TA2115TB x 1-11/16	902026	6.1	3/8 x 3/16 x 7.80	TA2115TBS x 1-11/16	902033	6.6	3/8 x 3/16 x 4.80
TA2115TB x 1-5/8	902027	6.0	3/8 x 3/16 x 7.80	TA2115TBS x 1-5/8	902034	6.8	3/8 x 3/16 x 4.80
TA2115TB x 1-1/2	902028	6.4	3/8 x 3/16 x 7.80	TA2115TBS x 1-1/2	902035	7.3	3/8 x 3/16 x 4.80
TA2115TB x 1-7/16	902029	6.4	3/8 x 3/16 x 7.80	TA2115TBS x 1-7/16	902036	7.4	3/8 x 3/16 x 4.80
TA2115TB x 1-3/8	902060	6.5	5/16 x 5/32 x 7.80	TA2115TBS x 1-3/8	902037	7.6	5/16 x 5/32 x 4.80
TA2115TB x 1-5/16	902061	6.7	5/16 x 5/32 x 7.80	TA2115TBS x 1-5/16	902038	7.8	5/16 x 5/32 x 4.80

- ▲ AGMA maximum bore size
- (5) Bushing kit required to mount TA II reducer to driven shaft
- (6) Bushing kit is not required to mount TA II reducer on SCS Drive Shaft in a screw conveyor application
- (7) Standard Shaft Bushing Kit includes two standard bushings with back-up plates and snap rings, hardware and key
- (8) Short Shaft Bushing Kit includes one standard bushing; one long bushing with insertable wedge; two backup plates with snap rings; hardware and key. This is an optional bushing for after market, short shaft mounting.
- (9) Minimum keyseat and shaft length required to mount reducer with bushing kit
- (10) Always check the driven shaft and key for strength

FEATURES/BENEFITS PAGE G1-3	NOMENCLATURE PAGE G1-8	SELECTION PAGE G1-12	RELATED PRODUCTS PAGE G1-123
--------------------------------	---------------------------	-------------------------	---------------------------------

SELECTION/DIMENSIONS



TORQUE-ARM II Shaft Mount Speed Reducers SCREW CONVEYOR DRIVE - TA2115H, SINGLE AND DOUBLE REDUCTION

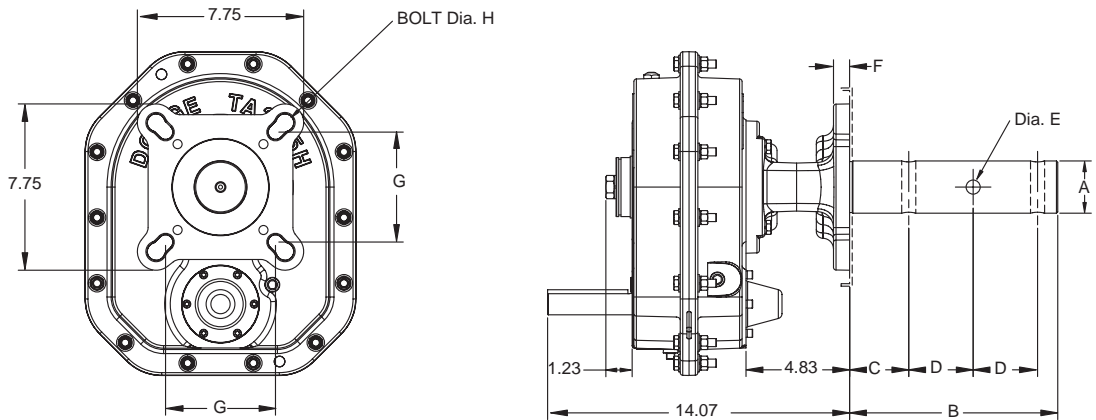

FEATURES/BENEFITS PAGE G1-3	NOMENCLATURE PAGE G1-8	SELECTION PAGE G1-12	RELATED PRODUCTS PAGE G1-123
--------------------------------	---------------------------	-------------------------	---------------------------------

SELECTION/DIMENSIONS



TORQUE-ARM II Shaft Mount Speed Reducers SCREW CONVEYOR DRIVE - TA2115H, SINGLE AND DOUBLE REDUCTION

TA2115H Screw Conveyor Drive Dimensions

Screw Dia	Drive Shaft Dia A	Dimensions						
		B	C	D	Hole Dia E	F	G	Bolt Dia H
6, 9	1-1/2	9.00	2.13	3.00	17/32	0.75	4.00	1/2-13
9, 12	2	9.00	2.13	3.00	21/32	0.75	5.13	5/8
12, 14	2-7/16	9.69	2.75	3.00	21/32	0.75	5.63	5/8
12, 14, 16, 18, 20	3	9.88	2.88	3.00	25/32	0.75	6.00	3/4

TA2115H Accessories for Screw Conveyor Drives ⁽¹⁾ ⁽⁴⁾ ⁽⁵⁾

Description	Part Number	Weight lbs.
TA2115SCA Adapter & Hardware Kit	902070	19.2
TA2115SCP Adjustable Packing Kit ⁽²⁾	902071	1.2
TA2115SCS x 1-1/2 Drive Shaft ⁽³⁾	902072	15.4
TA2115SCS x 2 Drive Shaft	902073	18.6
TA2115SCS x 2-7/16 Drive Shaft	902074	23.3
TA2115SCS x 3 Drive Shaft	902075	29.5
TA2115SCS x 1-1/2 Stainless Steel Drive Shaft	902080	15.4
TA2115SCS x 2 Stainless Steel Drive Shaft	902081	18.6
TA2115SCS x 2-7/16 Stainless Steel Drive Shaft	902082	23.3
TA2115SCS x 3 Stainless Steel Drive Shaft	902083	29.5

- (1) See page G1-53 for Belt Guard for Screw Conveyor Drive applications
- (2) SCA Adapter & Hardware Kit includes adapter, mounting wedge, keeper plate, key, seals and hardware
- (3) SCP Adjustable Packing Kit consists of flange, mounting hardware and braided packing seals
- (4) SCS Drive Shaft is a shaft only. Hardware is stocked with the adapter and hardware kit
- (5) A complete TA II Screw Conveyor Drive includes a TA II Reducer, SCA Adapter & Hardware Kit, and SCS Drive Shaft. The SCP Adjustable Packing Kit is an optional accessory

FEATURES/BENEFITS PAGE G1-3	NOMENCLATURE PAGE G1-8	SELECTION PAGE G1-12	RELATED PRODUCTS PAGE G1-123
--------------------------------	---------------------------	-------------------------	---------------------------------

SELECTION/DIMENSIONS



TORQUE-ARM II Shaft Mount Speed Reducers MOTOR MOUNT DIMENSIONS - TA2115H, POSITION B & D

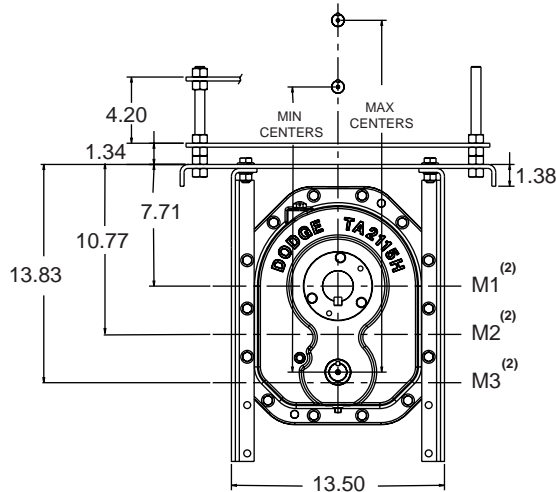

POSITION B

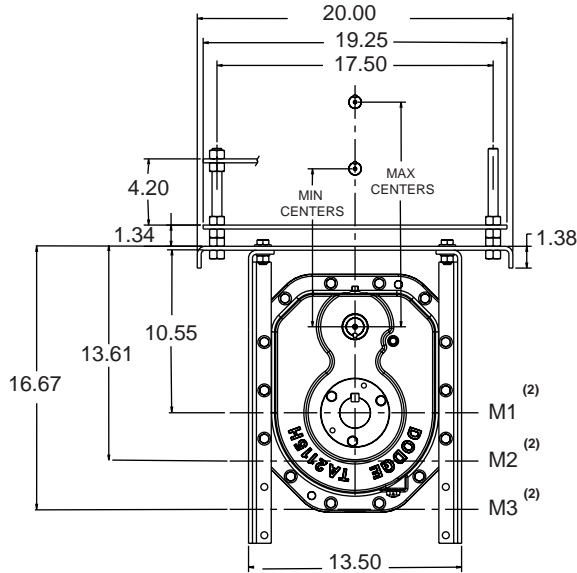

POSITION D

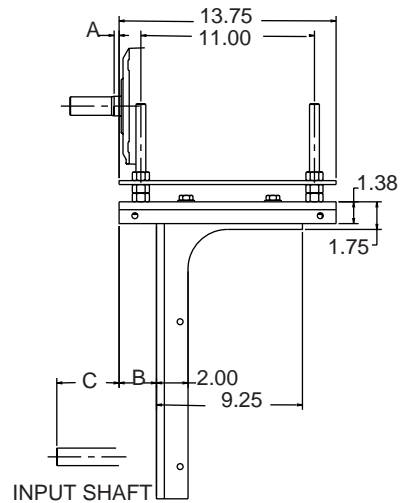

<p>FEATURES/BENEFITS PAGE G1-3</p>	<p>NOMENCLATURE PAGE G1-8</p>	<p>SELECTION PAGE G1-12</p>	<p>RELATED PRODUCTS PAGE G1-123</p>
--	-----------------------------------	---------------------------------	---

SELECTION/DIMENSIONS



TORQUE-ARM II Shaft Mount Speed Reducers

MOTOR MOUNT DIMENSIONS - TA2115H, POSITION B & D ⁽¹⁾

Mounting	Lateral Adjustment				Motor Mount Height (2)	Motor Frame					
						56			143T & 145T		
	B Min	B Max	C Min	C Max		A	Centers		A	Centers	
							Min	Max		Min	Max
Position B	0.19	3.61	2.32	5.74	M1	0.78	18.5	22.2	1.22	18.5	22.2
					M2		21.6	25.3		21.6	25.3
					M3		24.6	28.3		24.6	28.3
Position D	0.19	3.61	2.32	5.74	M1	0.78	10.4	14.1	1.22	10.4	14.1
					M2		13.5	17.2		13.5	17.2
					M3		16.6	20.3		16.6	20.3

Mounting	Motor Mount Height (2)	Motor Frame								
		182T & 184T			213T & 215T			254T & 256T		
		A	Centers		A	Centers		A	Centers	
			Min	Max		Min	Max		Min	Max
Position B	M1	1.37	19.5	23.2	1.55	20.3	24.0	1.56	21.3	25.0
	M2		22.6	26.3		23.3	27.0		24.3	28.0
	M3		25.6	29.3		26.4	30.1		27.4	31.1
Position D	M1	1.37	11.4	15.1	1.55	12.2	15.9	1.56	13.2	16.9
	M2		14.5	18.2		15.3	19.0		16.3	20.0
	M3		17.6	21.3		18.3	22.0		19.3	23.0

Note:

Minimum centers contain 0.5" to allow for belt assembly

(1) Motor mount will fit NEMA and IEC frame motors; hardware are inch dimensions

(2) M1, M2, M3 go through output shaft centerline

FEATURES/BENEFITS PAGE G1-3	NOMENCLATURE PAGE G1-8	SELECTION PAGE G1-12	RELATED PRODUCTS PAGE G1-123
--------------------------------	---------------------------	-------------------------	---------------------------------

SELECTION/DIMENSIONS



TORQUE-ARM II Shaft Mount Speed Reducers MOTOR MOUNT DIMENSIONS - TA2115H, POSITION A & C

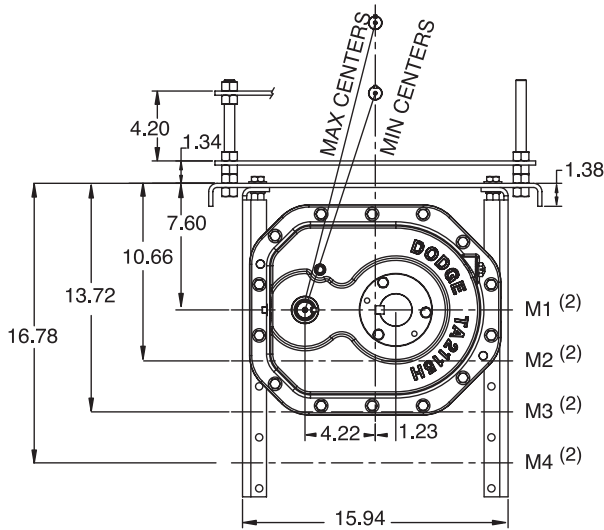

POSITION A

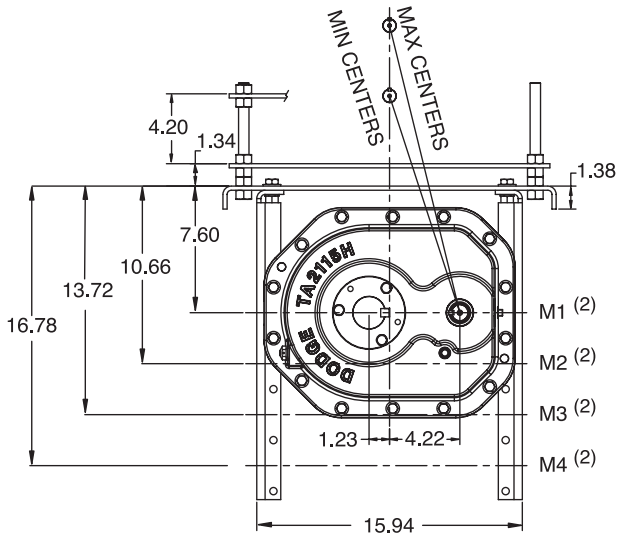

POSITION C

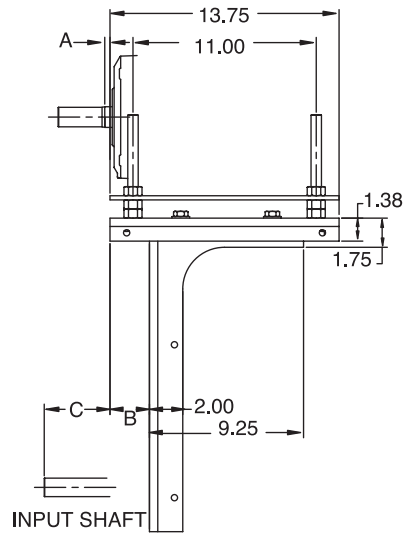

FEATURES/BENEFITS PAGE G1-3	NOMENCLATURE PAGE G1-8	SELECTION PAGE G1-12	RELATED PRODUCTS PAGE G1-123
--------------------------------	---------------------------	-------------------------	---------------------------------

SELECTION/DIMENSIONS



TORQUE-ARM II Shaft Mount Speed Reducers

MOTOR MOUNT DIMENSIONS - TA2115H, POSITION A & C (1) (3)

Mounting	Lateral Adjustment				Motor Mount Height (2)	Motor Frame					
						56			143T & 145T		
	B Min	B Max	C Min	C Max		A	Centers		A	Centers	
Min					Max		Min	Max			
Position A	0.19	3.61	3.39	6.81	M1	0.78	13.6	17.2	1.22	13.6	17.2
					M2		16.6	20.1		16.6	20.1
					M3		19.5	23.1		19.5	23.1
					M4		22.5	26.2		22.5	26.2
Position C	0.19	3.61	3.39	6.81	M1	0.78	13.6	17.2	1.22	13.6	17.2
					M2		16.6	20.1		16.6	20.1
					M3		19.5	23.1		19.5	23.1
					M4		22.5	26.2		22.5	26.2

Mounting	Motor Mount Height (2)	Motor Frame								
		182T & 184T			213T & 215T			254T & 256T		
		A	Centers		A	Centers		A	Centers	
Min	Max		Min	Max		Min	Max			
Position A	M1	1.37	14.6	18.1	1.55	15.3	18.9	1.56	16.3	19.8
	M2		17.5	21.1		18.3	21.9		19.2	22.8
	M3		20.5	24.1		21.2	24.9		22.2	25.9
	M4		23.5	27.1		24.2	27.9		25.2	28.9
Position C	M1	1.37	14.6	18.1	1.55	15.3	18.9	1.56	16.3	19.8
	M2		17.5	21.1		18.3	21.9		19.2	22.8
	M3		20.5	24.1		21.2	24.9		22.2	25.9
	M4		23.5	27.1		24.2	27.9		25.2	28.9

Note:

Minimum centers contain 0.5" to allow for belt assembly

- (1) Motor mount will fit NEMA and IEC frame motors; hardware are inch dimensions
- (2) M1, M2, M3, M4 go through output shaft centerline
- (3) See Table A, below, for minimum "M" mounting position required for specific screw diameter and reducer size

Table A - Screw Conveyor Motor Mount Minimum "M" Mounting Positions (1)

Nominal Screw Dia	Trough Height Dim	Minimum Mounting Position							
		TA0107L	TA1107H	TA2115H	TA3203H	TA4207H	TA5215H	TA6307H	TA7315H
6	7.00	M2	M3	M2	M2	M2	M1	M1	M1
9	9.00	M3	M4	M3	M3	M2	M2	M2	M1
12	10.00	M4	M4	M3	M3	M2	M2	M2	M1
14	11.00	M4	M4	M4	M3	M3	M2	M2	M2
16	11.50	M4	***	M4	M4	M3	M2	M2	M2
18	12.13	***	***	M4	M4	M3	M3	M2	M2
20	13.50	***	***	M4	M4	M3	M3	M3	M2
24	16.50	***	***	***	***	M4	M3	M3	M3

(1) For U Or Flared Trough Ends Per CEMA 300-014

FEATURES/BENEFITS PAGE G1-3	NOMENCLATURE PAGE G1-8	SELECTION PAGE G1-12	RELATED PRODUCTS PAGE G1-123
--------------------------------	---------------------------	-------------------------	---------------------------------

SELECTION/DIMENSIONS



TORQUE-ARM II Shaft Mount Speed Reducers TAPER BUSHED REDUCER - TA3203H, SINGLE AND DOUBLE REDUCTION

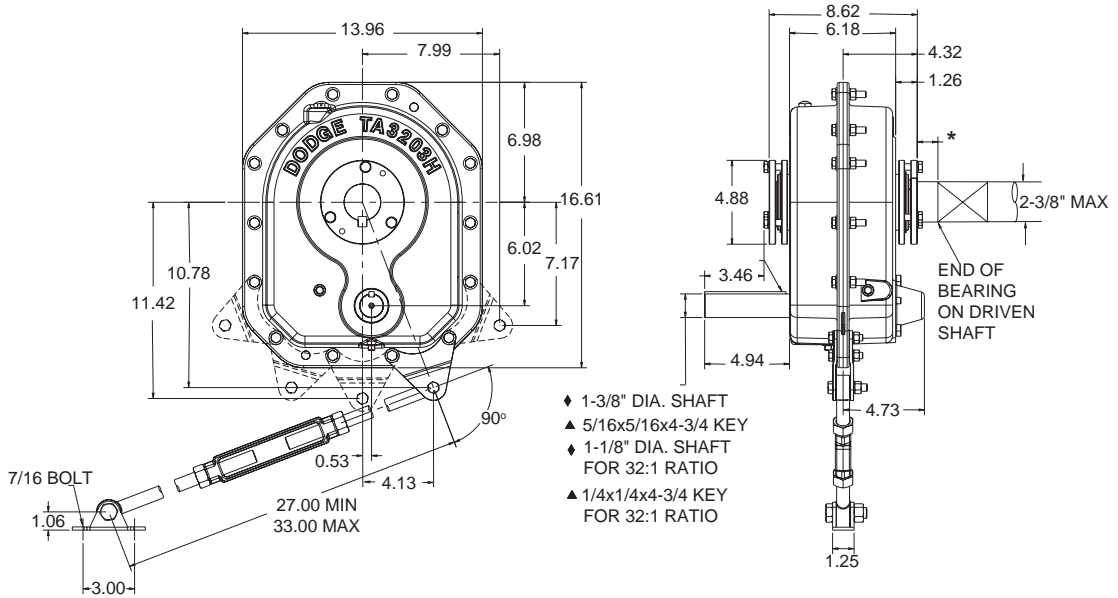

- ◆ 1-3/8" DIA. SHAFT
- ▲ 5/16x5/16x4-3/4 KEY
- ◆ 1-1/8" DIA. SHAFT FOR 32:1 RATIO
- ▲ 1/4x1/4x4-3/4 KEY FOR 32:1 RATIO

* 1.20 MINIMUM DISTANCE FOR BUSHING SCREW REMOVAL

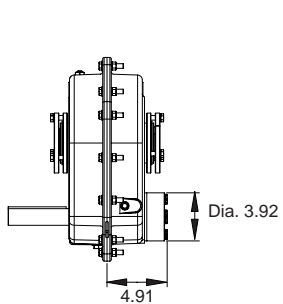

REDUCER WITH BACKSTOP

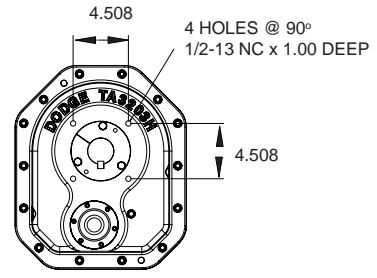

FLANGE MOUNTING DIMENSIONS

FEATURES/BENEFITS PAGE G1-3	NOMENCLATURE PAGE G1-8	SELECTION PAGE G1-12	RELATED PRODUCTS PAGE G1-123
--------------------------------	---------------------------	-------------------------	---------------------------------



TORQUE-ARM II Shaft Mount Speed Reducers TAPER BUSHED REDUCER - TA3203H, SINGLE AND DOUBLE REDUCTION

TA3203H Taper Bushed Reducers ⁽¹⁾ ■

Reducer Size	Part Number	AGMA Code	Actual Ratio	Weight lbs.
TA3203H05	903004	203S05	4.91	107.9
TA3203H09	903003	203D09	9.23	112.0
TA3203H15	903002	203D15	15.07	111.8
TA3203H25	903001	203D25	24.95	111.4
TA3203H32	903000	203D32	32.45	110.3

(1) Reducers are supplied from stock ready for vertical mounting and for flange mounting. Rod assembly is not included with reducer. Order as a separate part number.

■ See page G1-124 for Maximum Bore Straight Bore TA II Reducers

TA3203H Accessories

Description	Part Number	Weight Lbs
TA3203RA Rod Assembly ⁽¹⁾	903109	6.9
TA3203BS Backstop Assembly ⁽²⁾	903102	4.7
TA3203MM Motor Mount Assembly (143-286T) ⁽³⁾	903090	86.7
TA3203BG Belt Guard - Pos. B (143-286T)	903096	65.5
TA3203BG Belt Guard - Pos. C (143-286T) ⁽⁴⁾	903097	67.9
TA0-TA3 Vertical Breather Kit	900112	2.0
Filter Breather Plug	430048	0.2

- (2) See page G1-130 for input shaft speed necessary for backstop sprag lift-off
- (3) Motor Mount will fit NEMA and IEC frame motors; however hardware are inch dimensions
- (4) Use Position-C belt guard for TA II reducer in screw conveyor drive applications

TA3203H Tapered Bushing Kits ⁽⁵⁾ (6)

Bushing Size Standard Shaft Bushing Kit	Part Number (7)	Weight lbs.	Shaft Keyseat Required (9) (10)	Bushing Size	Part Number	Weight lbs.	Shaft Keyseat Required (9) (10)
				Short Driven Shaft Bushing Kit (8)			
TA3203TB x 2-3/8	903020	6.1	5/8 x 5/16 x 8.55	---	---	---	---
TA3203TB x 2-1/4	903021	6.2	1/2 x 1/4 x 8.55	---	---	---	---
TA3203TB x 2-3/16 ▲	903022	6.8	1/2 x 1/4 x 8.55	TA3203TBS x 2-3/16	903030	7.0	1/2 x 1/4 x 5.46
TA3203TB x 2-1/8	903023	7.0	1/2 x 1/4 x 8.55	TA3203TBS x 2-1/8	903031	7.4	1/2 x 1/4 x 5.46
TA3203TB x 2	903024	7.5	1/2 x 1/4 x 8.55	TA3203TBS x 2	903032	8.0	1/2 x 1/4 x 5.46
TA3203TB x 1-15/16	903025	7.8	1/2 x 1/4 x 8.55	TA3203TBS x 1-15/16	903033	8.4	1/2 x 1/4 x 5.46
TA3203TB x 1-7/8	903026	8.0	1/2 x 1/4 x 8.55	TA3203TBS x 1-7/8	903034	8.7	1/2 x 1/4 x 5.46
TA3203TB x 1-3/4	903027	8.0	3/8 x 3/16 x 8.55	TA3203TBS x 1-3/4	903035	9.0	3/8 x 3/16 x 5.46
TA3203TB x 1-11/16	903028	8.2	3/8 x 3/16 x 8.55	TA3203TBS x 1-11/16	903036	9.3	3/8 x 3/16 x 5.46
TA3203TB x 1-5/8	903029	8.4	3/8 x 3/16 x 8.55	TA3203TBS x 1-5/8	903037	9.6	3/8 x 3/16 x 5.46
TA3203TB x 1-1/2	903060	8.8	3/8 x 3/16 x 8.55	TA3203TBS x 1-1/2	903038	9.9	3/8 x 3/16 x 5.46
TA3203TB x 1-7/16	903061	8.8	3/8 x 3/16 x 8.55	TA3203TBS x 1-7/16	903039	10.0	3/8 x 3/16 x 5.46

▲ AGMA maximum bore size

(5) Bushing kit required to mount TA II reducer to driven shaft

(6) Bushing kit is not required to mount TA II reducer on SCS Drive Shaft in a screw conveyor application

(7) Standard Shaft Bushing Kit includes two standard bushings with back-up plates and snap rings, hardware and key

(8) Short Shaft Bushing Kit includes one standard bushing; one long bushing with insertable wedge; key, two backup plates with snap rings; hardware and key. This is an optional bushing for after market, short shaft mounting.

(9) Minimum keyseat and shaft length required to mount reducer with bushing kit

(10) Always check the driven shaft and key for strength

FEATURES/BENEFITS PAGE G1-3	NOMENCLATURE PAGE G1-8	SELECTION PAGE G1-12	RELATED PRODUCTS PAGE G1-123
--------------------------------	---------------------------	-------------------------	---------------------------------

SELECTION/DIMENSIONS



TORQUE-ARM II Shaft Mount Speed Reducers SCREW CONVEYOR DRIVE - TA3203H, SINGLE AND DOUBLE REDUCTION

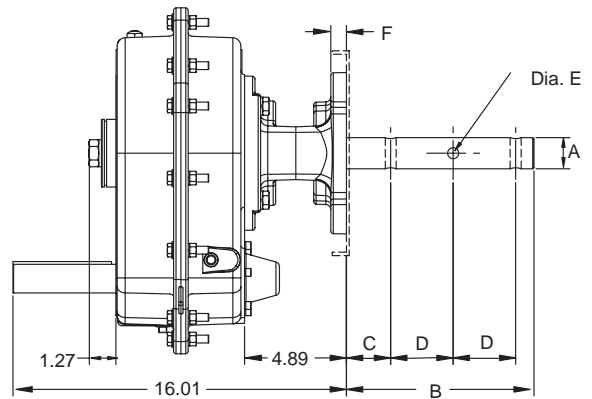
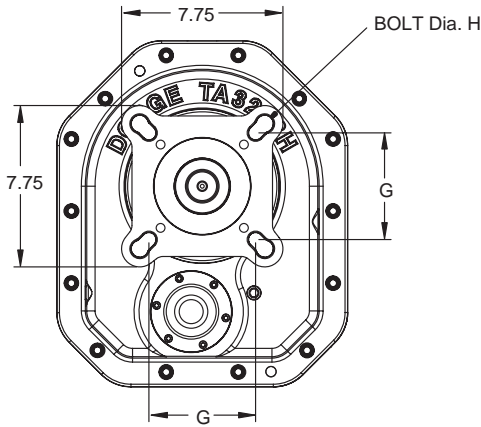

FEATURES/BENEFITS PAGE G1-3	NOMENCLATURE PAGE G1-8	SELECTION PAGE G1-12	RELATED PRODUCTS PAGE G1-123
--------------------------------	---------------------------	-------------------------	---------------------------------

SELECTION/DIMENSIONS



TORQUE-ARM II Shaft Mount Speed Reducers SCREW CONVEYOR DRIVE - TA3203H, SINGLE AND DOUBLE REDUCTION

TA3203H Screw Conveyor Drive Dimensions

Screw Dia	Drive Shaft Dia A	Dimensions						
		B	C	D	Hole Dia E	F	G	Bolt Dia H
6, 9	1-1/2	9.00	2.13	3.00	17/32	0.75	4.00	1/2-13
9, 12	2	9.00	2.13	3.00	21/32	0.75	5.13	5/8
12, 14	2-7/16	9.69	2.75	3.00	21/32	0.75	5.63	5/8
12, 14, 16, 18, 20	3	9.88	2.88	3.00	25/32	0.75	6.00	3/4
18, 20, 24	3-7/16	13.13	3.88	4.00	29/32	.75	6.75	3/4

TA3203H Accessories for Screw Conveyor Drives ⁽¹⁾ ⁽⁴⁾ ⁽⁵⁾

Description	Part Number	Weight lbs.
TA3203SCA Adapter & Hardware Kit ⁽²⁾	903070	22.0
TA3203SCP Adjustable Packing Kit ⁽³⁾	903071	1.4
TA3203SCS x 1-1/2 Drive Shaft	903072	19.3
TA3203SCS x 2 Drive Shaft	903073	22.6
TA3203SCS x 2-7/16 Drive Shaft	903074	27.2
TA3203SCS x 3 Drive Shaft	903075	33.6
TA3203SCS x 3-7/16 Drive Shaft	903076	44.8
TA3203SCS x 1-1/2 Stainless Steel Drive Shaft	903080	19.3
TA3203SCS x 2 Stainless Steel Drive Shaft	903081	22.6
TA3203SCS x 2-7/16 Stainless Steel Drive Shaft	903082	27.2
TA3203SCS x 3 Stainless Steel Drive Shaft	903083	33.6
TA3203SCS x 3-7/16 Stainless Steel Drive Shaft	903084	44.8

- (1) See page G1-61 for Belt Guard for Screw Conveyor Drive applications
- (2) SCA Adapter & Hardware Kit includes adapter, mounting wedge, keeper plate, key, seals and hardware
- (3) SCP Adjustable Packing Kit consists of flange, mounting hardware and braided packing seals
- (4) SCS Drive Shaft is a shaft only. Hardware is stocked with the adapter and hardware kit
- (5) A complete TA II Screw Conveyor Drive includes a TA II Reducer, SCA Adapter & Hardware Kit, and SCS Drive Shaft. The SCP Adjustable Packing Kit is an optional accessory.

FEATURES/BENEFITS PAGE G1-3	NOMENCLATURE PAGE G1-8	SELECTION PAGE G1-12	RELATED PRODUCTS PAGE G1-123
--------------------------------	---------------------------	-------------------------	---------------------------------



SELECTION/DIMENSIONS

TORQUE-ARM II Shaft Mount Speed Reducers MOTOR MOUNT DIMENSIONS - TA3203H, POSITION B & D

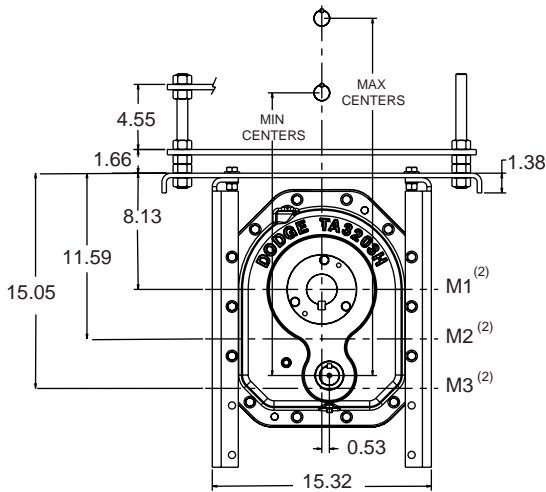

POSITION B

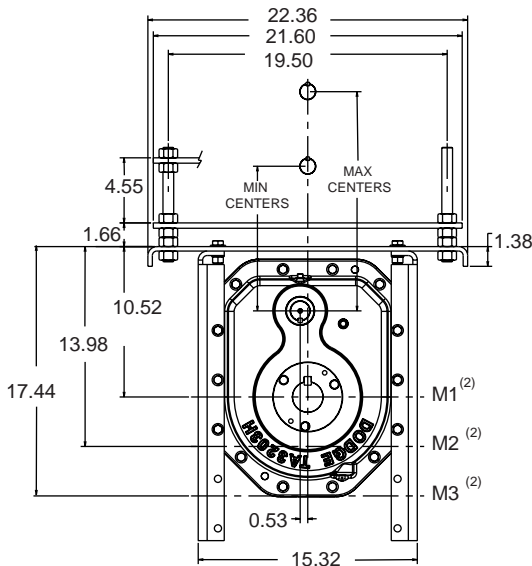

POSITION D

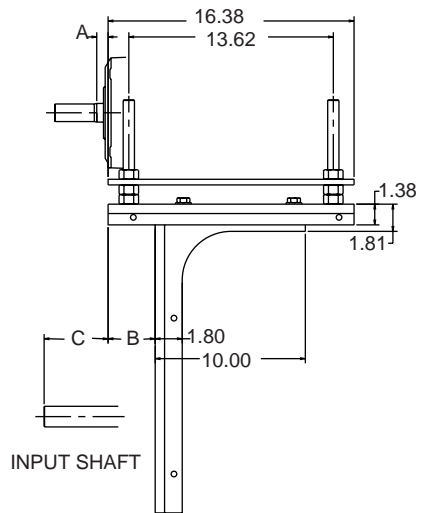

FEATURES/BENEFITS PAGE G1-3	NOMENCLATURE PAGE G1-8	SELECTION PAGE G1-12	RELATED PRODUCTS PAGE G1-123
--------------------------------	---------------------------	-------------------------	---------------------------------

SELECTION/DIMENSIONS



TORQUE-ARM II Shaft Mount Speed Reducers

MOTOR MOUNT DIMENSIONS - TA3203H, POSITION B & D ⁽¹⁾

Mounting	Lateral Adjustment				Motor Mount Height (2)	Motor Frame					
						143T & 145T			182T & 184T		
	B Min	B Max	C Min	C Max		A	Centers		A	Centers	
Min					Max		Min	Max			
Position B	0.04	5.34	2.06	7.36	M1	1.22	19.8	23.9	1.37	20.8	24.9
					M2		23.3	27.3		24.3	28.3
					M3		26.7	30.8		27.7	31.8
Position D	0.04	5.34	2.06	7.36	M1	1.22	10.2	14.2	1.37	11.2	15.2
					M2		13.6	17.7		14.6	18.7
					M3		17.1	21.1		18.1	22.1

Mounting	Motor Mount Height (2)	Motor Frame								
		213T & 215T			254T & 256T			284T & 286T		
		A	Centers		A	Centers		A	Centers	
Min	Max		Min	Max		Min	Max			
Position B	M1	1.55	21.6	25.6	1.56	22.6	26.6	1.16	23.3	27.4
	M2		25.0	29.1		26.0	30.1		26.8	30.8
	M3		28.5	32.5		29.5	33.5		30.2	34.3
Position D	M1	1.55	11.9	16.0	1.56	12.9	17.0	1.16	13.7	17.7
	M2		15.4	19.4		16.4	20.4		17.1	21.2
	M3		18.8	22.9		19.8	23.9		20.6	24.6

Note:

Minimum centers contain 0.5" to allow for belt assembly

(1) Motor mount will fit NEMA and IEC frame motors; hardware are inch dimensions

(2) M1, M2, M3 go through output shaft centerline

FEATURES/BENEFITS PAGE G1-3	NOMENCLATURE PAGE G1-8	SELECTION PAGE G1-12	RELATED PRODUCTS PAGE G1-123
--------------------------------	---------------------------	-------------------------	---------------------------------

SELECTION/DIMENSIONS



TORQUE-ARM II Shaft Mount Speed Reducers MOTOR MOUNT DIMENSIONS - TA3203H, POSITION A & C

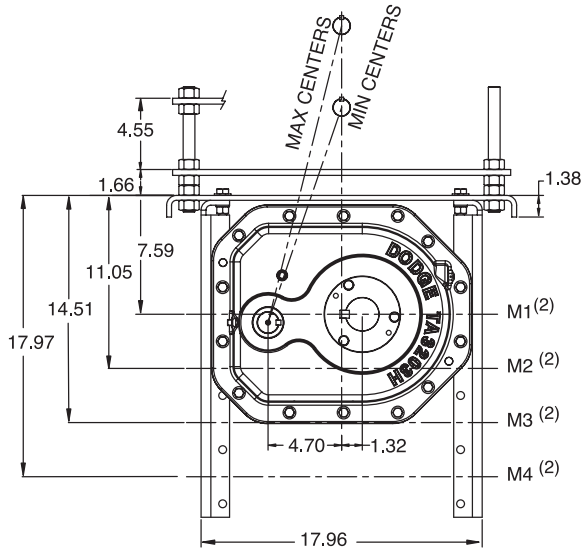

POSITION A

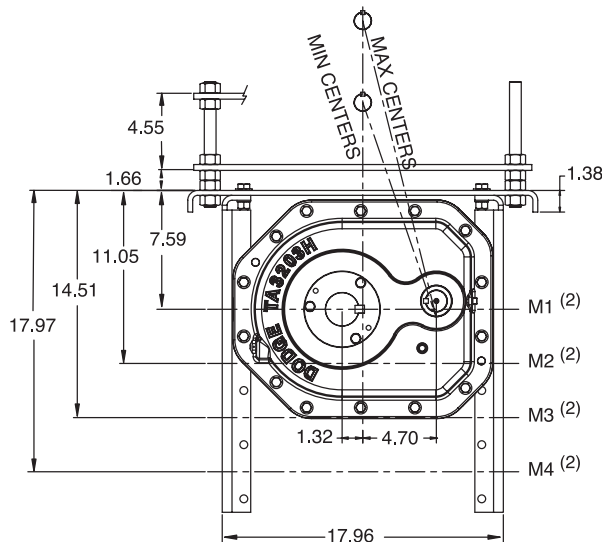

POSITION C

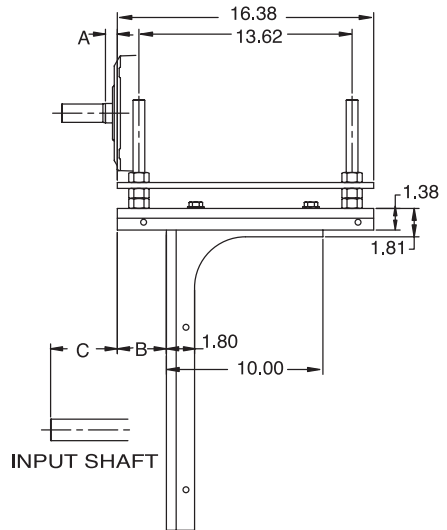

INPUT SHAFT

<p>FEATURES/BENEFITS PAGE G1-3</p>	<p>NOMENCLATURE PAGE G1-8</p>	<p>SELECTION PAGE G1-12</p>	<p>RELATED PRODUCTS PAGE G1-123</p>
--	-----------------------------------	---------------------------------	---

SELECTION/DIMENSIONS



TORQUE-ARM II Shaft Mount Speed Reducers

MOTOR MOUNT DIMENSIONS - TA3203H, POSITION A & C (1) (3)

Mounting	Lateral Adjustment				Motor Mount Height (2)	Motor Frame					
						143T & 145T			182T & 184T		
	B Min	B Max	C Min	C Max		A	Centers		A	Centers	
Min					Max		Min	Max			
Position A	0.04	5.34	3.07	8.37	M1	1.22	14.6	18.4	1.37	15.5	19.4
					M2		17.9	21.8		18.9	22.8
					M3		21.2	25.2		22.2	26.2
					M4		24.6	28.6		25.6	29.6
Position C	0.04	5.34	3.07	8.37	M1	1.22	13.6	17.4	1.37	14.5	18.4
					M2		16.9	20.8		17.8	21.7
					M3		20.2	24.2		21.2	25.1
					M4		23.6	27.6		24.6	28.5

Mounting	Motor Mount Height (2)	Motor Frame								
		213T & 215T			254T & 256T			284T & 286T		
		A	Centers		A	Centers		A	Centers	
Min	Max		Min	Max		Min	Max			
Position A	M1	1.55	16.2	20.1	1.56	17.2	21.1	1.16	17.9	21.8
	M2		19.6	23.5		20.5	24.5		21.3	25.2
	M3		22.9	26.9		23.9	27.9		24.7	28.6
	M4		26.3	30.3		27.3	31.3		28.1	32.1
Position C	M1	1.55	15.2	19.1	1.56	16.2	20.1	1.16	16.9	20.8
	M2		18.6	22.5		19.5	23.5		20.2	24.2
	M3		21.9	25.9		22.9	26.9		23.6	27.6
	M4		25.3	29.3		26.3	30.3		27.0	31.0

Note:

Minimum centers contain 0.5" to allow for belt assembly

- (1) Motor mount will fit NEMA and IEC frame motors; hardware are inch dimensions
- (2) M1, M2, M3, M4 go through output shaft centerline
- (3) See Table A, below, for minimum "M" mounting position required for specific screw diameter and reducer size

Table A - Screw Conveyor Motor Mount Minimum "M" Mounting Positions (1)

Nominal Screw Dia	Trough Height Dim	Minimum Mounting Position							
		TA0107L	TA1107H	TA2115H	TA3203H	TA4207H	TA5215H	TA6307H	TA7315H
6	7.00	M2	M3	M2	M2	M2	M1	M1	M1
9	9.00	M3	M4	M3	M3	M2	M2	M2	M1
12	10.00	M4	M4	M3	M3	M2	M2	M2	M1
14	11.00	M4	M4	M4	M3	M3	M2	M2	M2
16	11.50	M4	***	M4	M4	M3	M2	M2	M2
18	12.13	***	***	M4	M4	M3	M3	M2	M2
20	13.50	***	***	M4	M4	M3	M3	M3	M2
24	16.50	***	***	***	***	M4	M3	M3	M3

(1) For U Or Flared Trough Ends Per CEMA 300-014

FEATURES/BENEFITS PAGE G1-3	NOMENCLATURE PAGE G1-8	SELECTION PAGE G1-12	RELATED PRODUCTS PAGE G1-123
--------------------------------	---------------------------	-------------------------	---------------------------------

SELECTION/DIMENSIONS



TORQUE-ARM II Shaft Mount Speed Reducers

TAPER BUSHED REDUCERS - TA4207H, SINGLE AND DOUBLE REDUCTION

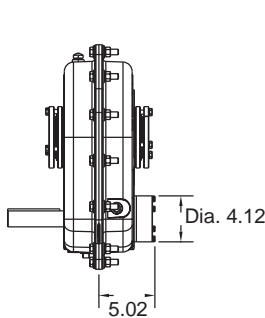
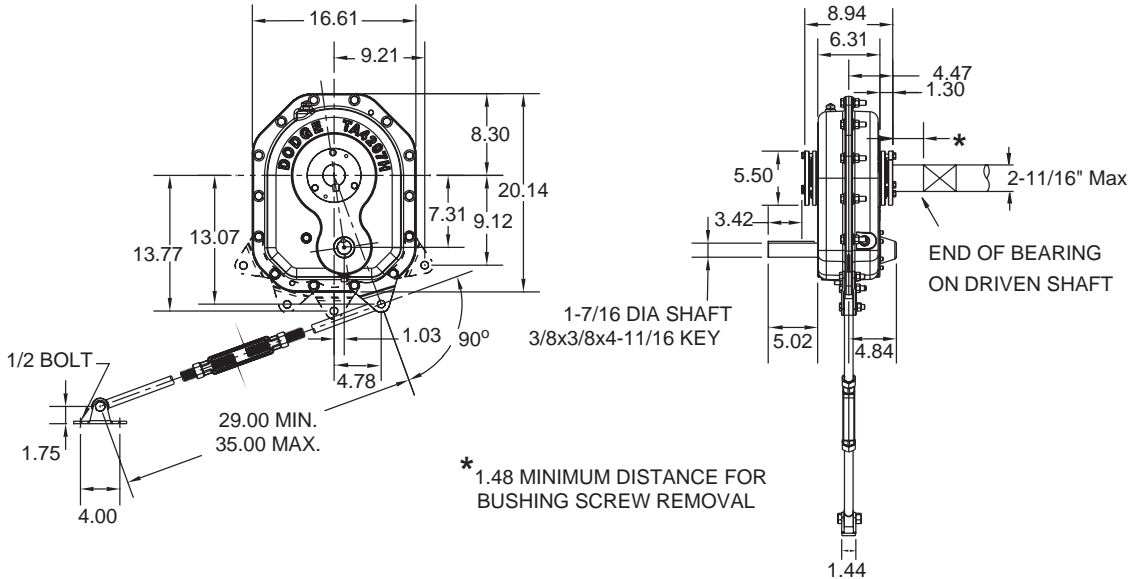

REDUCER WITH BACKSTOP

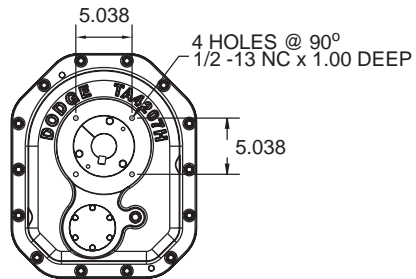

FLANGE MOUNTING DIMENSIONS

FEATURES/BENEFITS PAGE G1-3	NOMENCLATURE PAGE G1-8	SELECTION PAGE G1-12	RELATED PRODUCTS PAGE G1-123
--------------------------------	---------------------------	-------------------------	---------------------------------



TORQUE-ARM II Shaft Mount Speed Reducers TAPER BUSHED REDUCERS - TA4207H, SINGLE AND DOUBLE REDUCTION

TA4207H Taper Bushed Reducers ⁽¹⁾ ■

Reducer Size	Part Number	AGMA Code	Actual Ratio	Weight lbs.
TA4207H05	904004	207S05	5.00	178.5
TA4207H09	904003	207D09	9.23	187.1
TA4207H15	904002	207D15	15.00	186.7
TA4207H25	904001	207D25	25.13	186.0
TA4207H40	904000	207D40	39.11	185.4

(1) Reducers are supplied from stock ready for vertical mounting and for flange mounting. Rod assembly is not included with reducer. Order as a separate part number.

■ See page G1-130 for Maximum Bore Straight Bore TA II Reducers

TA4207H Accessories

Description	Part Number	Weight lbs.
TA4207RA Rod Assembly ⁽¹⁾	904109	10.6
TA4207BS Backstop Assembly ⁽²⁾	904102	5.2
TA4207BS 40:1 Backstop Assembly ⁽²⁾	904103	5.2
TA4207MM Motor Mount Assembly (143-326T) ⁽³⁾	904090	114.3
TA4207BG Belt Guard - Pos. B (143-326T)	904096	79.6
TA4207BG Belt Guard - Pos. C (143-326T) ⁽⁴⁾	904097	82.7
TA4207CF Cooling Fan Assembly ●	904106	2.0
TA4-TA12 Vertical Breather Kit	904112	3.0
Filter Breather Assy	430049	0.2

(2) See page G1-130 for input shaft speed necessary for backstop sprag lift-off

(3) Motor Mount will fit NEMA and IEC frame motors; however hardware are inch dimensions

(4) Use Position-C belt guard for TA II reducer in screw conveyor drive applications

● See page G1-122 for cooling fan dimensions

TA4207H Tapered Bushing Kits ⁽⁵⁾ (6)

Bushing Size Standard Shaft Bushing Kit	Part Number (7)	Weight lbs.	Shaft Keyseat Required (9) (10)	Bushing Size	Part Number	Weight lbs.	Shaft Keyseat Required (9) (10)
				Short Shaft Bushing Kit (8)			
TA4207TB x 2-11/16	904020	9.4	5/8 x 5/16 x 8.93	---	---	---	---
TA4207TB x 2-1/2	904021	10.6	5/8 x 5/16 x 8.93	---	---	---	---
TA4207TB x 2-7/16 ▲	904022	10.8	5/8 x 5/16 x 8.93	TA4207TBS x 2-7/16	904032	11.3	5/8 x 5/16 x 5.65
TA4207TB x 2-3/8	904023	11.3	5/8 x 5/16 x 8.93	TA4207TBS x 2-3/8	904033	11.8	5/8 x 5/16 x 5.65
TA4207TB x 2-1/4	904024	11.5	1/2 x 1/4 x 8.93	TA4207TBS x 2-1/4	904034	12.4	1/2 x 1/4 x 5.65
TA4207TB x 2-3/16	904025	11.8	1/2 x 1/4 x 8.93	TA4207TBS x 2-3/16	904035	10.8	1/2 x 1/4 x 5.65
TA4207TB x 2-1/8	904026	12.2	1/2 x 1/4 x 8.93	TA4207TBS x 2-1/8	904036	13.3	1/2 x 1/4 x 5.65
TA4207TB x 2	904027	12.6	1/2 x 1/4 x 8.93	TA4207TBS x 2	904037	13.9	1/2 x 1/4 x 5.65
TA4207TB x 1-15/16	904028	13.0	1/2 x 1/4 x 8.93	TA4207TBS x 1-15/16	904038	14.3	1/2 x 1/4 x 5.65
TA4207TB x 1-7/8	904029	13.2	1/2 x 1/4 x 8.93	TA4207TBS x 1-7/8	904039	14.6	1/2 x 1/4 x 5.65
TA4207TB x 1-3/4	904030	13.3	3/8 x 3/16 x 8.93	TA4207TBS x 1-3/4	904040	15.0	3/8 x 3/16 x 5.65
TA4207TB x 1-11/16	904031	13.5	3/8 x 3/16 x 8.93	TA4207TBS x 1-11/16	904041	15.3	3/8 x 3/16 x 5.65

▲ AGMA maximum bore size

(5) Bushing kit required to mount TA II reducer to driven shaft

(6) Bushing kit is not required to mount TA II reducer on SCS Drive Shaft in a screw conveyor application

(7) Standard Shaft Bushing Kit includes two standard bushings with back-up plates and snap rings, hardware and key

(8) Short Shaft Bushing Kit includes one standard bushing; one long bushing with insertable wedge; two backup plates with snap rings; hardware and key. This is an optional bushing for after market, short shaft mounting.

(9) Minimum keyseat and shaft length required to mount reducer with bushing kit

(10) Always check the driven shaft and key for strength

FEATURES/BENEFITS PAGE G1-3	NOMENCLATURE PAGE G1-8	SELECTION PAGE G1-12	RELATED PRODUCTS PAGE G1-123
--------------------------------	---------------------------	-------------------------	---------------------------------

SELECTION/DIMENSIONS



TORQUE-ARM II Shaft Mount Speed Reducers SCREW CONVEYOR DRIVE - TA4207H, SINGLE AND DOUBLE REDUCTION

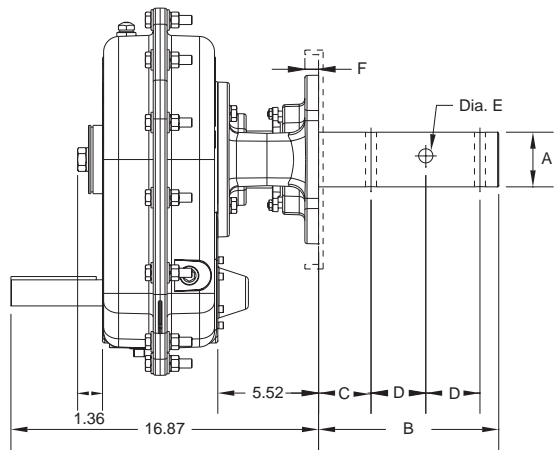
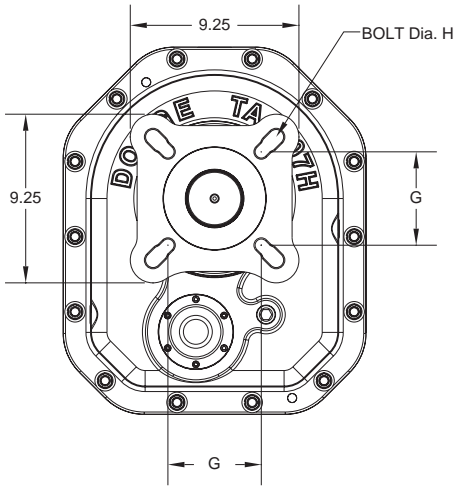

FEATURES/BENEFITS PAGE G1-3	NOMENCLATURE PAGE G1-8	SELECTION PAGE G1-12	RELATED PRODUCTS PAGE G1-123
--------------------------------	---------------------------	-------------------------	---------------------------------



TORQUE-ARM II Shaft Mount Speed Reducers SCREW CONVEYOR DRIVE - TA4207H, SINGLE AND DOUBLE REDUCTION

TA4207H Screw Conveyor Drive Dimensions

Screw Dia	Drive Shaft Dia A	Dimensions						
		B	C	D	Hole Dia E	F	G	Bolt Dia H
9, 12	2	9.00	2.13	3.00	21/32	0.75	5.13	5/8
12, 14	2-7/16	9.69	2.75	3.00	21/32	0.75	5.63	5/8
12, 14, 16, 18, 20	3	9.88	2.88	3.00	25/32	0.75	6.00	3/4
18, 20, 24	3-7/16	13.13	3.88	4.00	29/32	0.75	6.75	3/4

TA4207H Accessories for Screw Conveyor Drives (1) (4) (5)

Description	Part Number	Weight lbs.
TA4207SCA Adapter & Hardware Kit ⁽²⁾	904070	33.6
TA4207SCP Adjustable Packing Kit ⁽³⁾	904071	2.1
TA4207SCS x 2 Drive Shaft	904073	29.8
TA4207SCS x 2-7/16 Drive Shaft	904074	34.5
TA4207SCS x 3 Drive Shaft	904075	40.9
TA4207SCS x 3-7/16 Drive Shaft	904076	54.7
TA4207SCS x 2 Stainless Steel Drive Shaft	904081	29.8
TA4207SCS x 2-7/16 Stainless Steel Drive Shaft	904082	34.5
TA4207SCS x 3 Stainless Steel Drive Shaft	904083	40.9
TA4207SCS x 3-7/16 Stainless Steel Drive Shaft	904084	54.7

- (1) See page G1-69 for Belt Guard for Screw Conveyor Drive applications.
- (2) SCA Adapter & Hardware Kit includes adapter, mounting wedge, keeper plate, key, seals and hardware.
- (3) SCP Adjustable Packing Kit consists of flange, mounting hardware and braided packing seals.
- (4) SCS Drive Shaft is a shaft only. Mounting hardware is stocked with the adapter & hardware kit.
- (5) A complete TA II Screw Conveyor Drive includes a TA II Reducer, SCA Adapter & Hardware Kit, and SCS Drive Shaft. The SCP Adjustable Packing Kit is an optional accessory.

FEATURES/BENEFITS PAGE G1-3	NOMENCLATURE PAGE G1-8	SELECTION PAGE G1-12	RELATED PRODUCTS PAGE G1-123
--------------------------------	---------------------------	-------------------------	---------------------------------



SELECTION/DIMENSIONS

TORQUE-ARM II Shaft Mount Speed Reducers MOTOR MOUNT DIMENSIONS - TA4207H, POSITION B & D

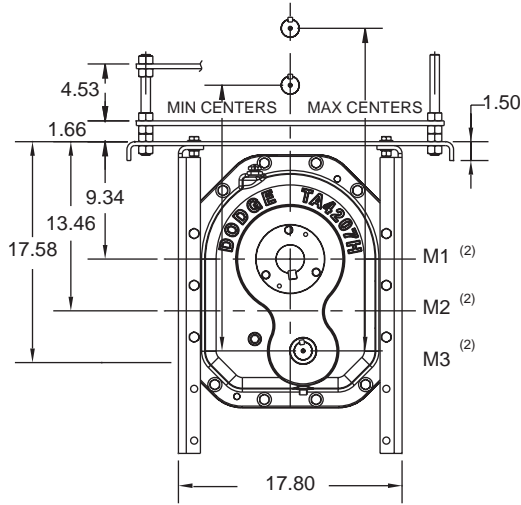

POSITION B

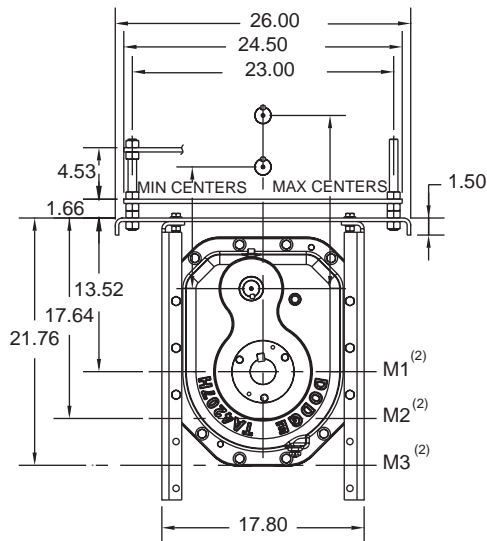

POSITION D

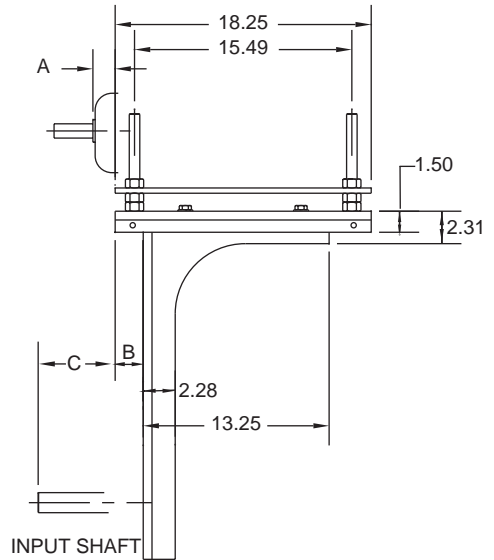

FEATURES/BENEFITS PAGE G1-3	NOMENCLATURE PAGE G1-8	SELECTION PAGE G1-12	RELATED PRODUCTS PAGE G1-123
--------------------------------	---------------------------	-------------------------	---------------------------------

SELECTION/DIMENSIONS



TORQUE-ARM II Shaft Mount Speed Reducers MOTOR MOUNT DIMENSIONS - TA4207H, POSITION B & D ⁽¹⁾

Mounting	Lateral Adjustment				Motor Mount Height (2)	Motor Frame								
						143T & 145T			182T & 184T			213T & 215T		
	B Min	B Max	C Min	C Max		A	Centers		A	Centers		A	Centers	
							Min	Max		Min	Max		Min	Max
Position B	-0.21	4.21	3.28	7.70	M1	1.22	22.6	26.7	1.37	23.6	27.7	1.55	24.4	28.4
					M2	26.8	30.8	27.8	31.8	28.5	32.5			
					M3	30.9	34.9	31.9	35.9	32.6	36.7			
Position D	-0.21	4.21	3.28	7.70	M1	1.22	12.2	16.2	1.37	13.2	17.2	1.55	14.0	18.0
					M2	16.3	20.4	17.3	21.4	18.1	22.1			
					M3	20.4	24.5	21.4	25.5	22.2	26.2			

Mounting	Lateral Adjustment				Motor Mount Height (2)	Motor Frame								
						254T & 256T			284T & 286T			324T & 326T		
	B Min	B Max	C Min	C Max		A	Centers		A	Centers		A	Centers	
							Min	Max		Min	Max		Min	Max
Position B	-0.21	4.21	3.28	7.70	M1	1.56	25.4	29.4	1.16	26.1	30.2	0.38	27.1	31.2
					M2	29.5	33.5	30.3	34.3	31.3	35.3			
					M3	33.6	37.7	34.4	38.4	35.4	39.4			
Position D	-0.21	4.21	3.28	7.70	M1	1.56	15.0	19.0	1.16	15.7	19.7	0.38	16.7	20.7
					M2	19.1	23.1	19.8	23.9	20.8	24.9			
					M3	23.2	27.2	23.9	28.0	24.9	29.0			

Notes:

Minimum centers contains 0.5" to allow for belt assembly

- (1) Motor mount will fit NEMA and IEC frame motors; hardware are inch dimensions
- (2) M1, M2, M3 go through output shaft centerline

FEATURES/BENEFITS PAGE G1-3	NOMENCLATURE PAGE G1-8	SELECTION PAGE G1-12	RELATED PRODUCTS PAGE G1-123
--------------------------------	---------------------------	-------------------------	---------------------------------

SELECTION/DIMENSIONS



TORQUE-ARM II Shaft Mount Speed Reducers MOTOR MOUNT DIMENSIONS - TA4207H, POSITION A & C

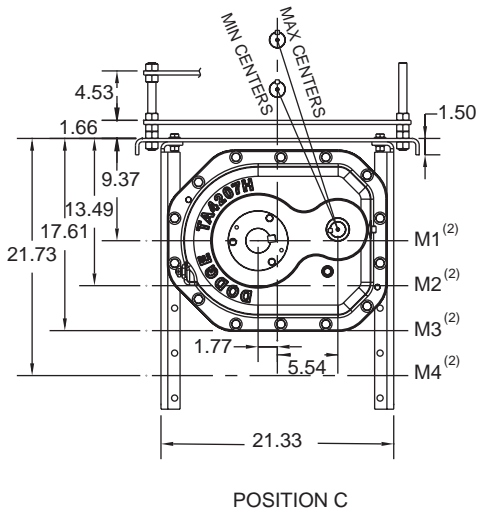
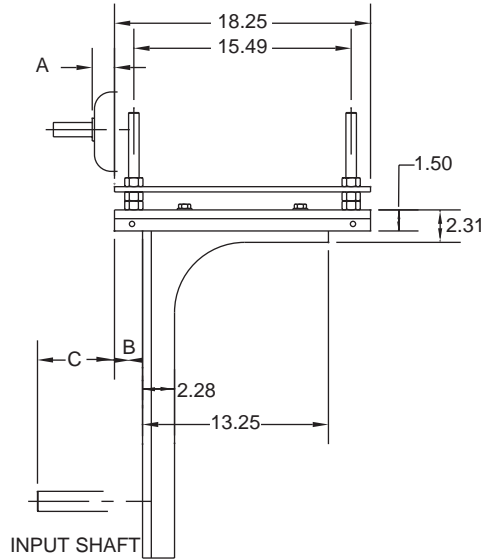
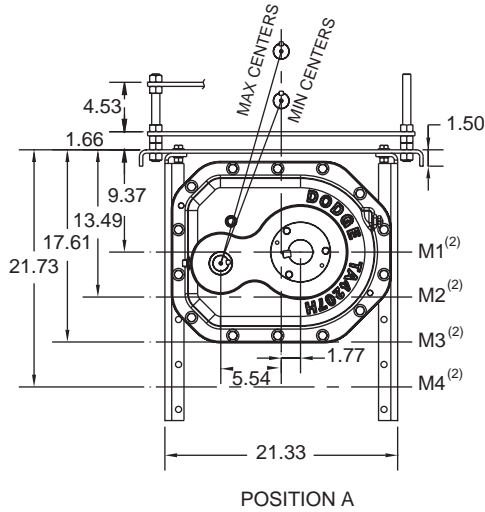

FEATURES/BENEFITS PAGE G1-3	NOMENCLATURE PAGE G1-8	SELECTION PAGE G1-12	RELATED PRODUCTS PAGE G1-123
--------------------------------	---------------------------	-------------------------	---------------------------------

SELECTION/DIMENSIONS



TORQUE-ARM II Shaft Mount Speed Reducers

MOTOR MOUNT DIMENSIONS - TA4207H, POSITION A & C (1) (3)

Mounting	Lateral Adjustment				Motor Mount Height (2)	Motor Frame								
						143T & 145T			182T & 184T			213T & 215T		
	B Min	B Max	C Min	C Max		A	Centers		A	Centers		A	Centers	
							Min	Max		Min	Max		Min	Max
Position A	-0.21	4.21	4.35	8.77	M1	1.22	17.3	21.1	1.37	18.3	22.1	1.55	19.0	22.8
					M2		21.2	25.1		22.2	26.1		22.9	26.8
					M3		25.2	29.2		26.2	30.2		26.9	30.9
					M4		29.3	33.2		30.2	34.2		31.0	34.9
Position C	-0.21	4.21	4.35	8.77	M1	1.22	15.4	19.2	1.37	16.3	20.1	1.55	17.0	20.8
					M2		19.3	23.1		20.2	24.1		20.9	24.8
					M3		23.2	27.2		24.2	28.1		24.9	28.9
					M4		27.3	31.2		28.2	32.2		29.0	32.9

Mounting	Lateral Adjustment				Motor Mount Height (2)	Motor Frame								
						254T & 256T			284T & 286T			324T & 326T		
	B Min	B Max	C Min	C Max		A	Centers		A	Centers		A	Centers	
							Min	Max		Min	Max		Min	Max
Position A	-0.21	4.21	4.35	8.77	M1	1.56	19.9	23.8	1.16	20.6	24.5	0.38	21.6	25.5
					M2		23.9	27.8		24.6	28.6		25.6	29.5
					M3		27.9	31.9		28.7	32.6		29.6	33.6
					M4		32.0	35.9		32.7	36.7		33.7	37.7
Position C	-0.21	4.21	4.35	8.77	M1	1.56	18.0	21.8	1.16	18.7	22.5	0.38	19.6	23.5
					M2		21.9	25.8		22.6	26.5		23.6	27.5
					M3		25.9	29.9		26.6	30.6		27.6	31.6
					M4		29.9	33.9		30.7	34.6		31.7	35.6

Notes:

Minimum centers contains 0.5" to allow for belt assembly

(1) Motor mount will fit NEMA and IEC frame motors; hardware are inch dimensions

(2) M1, M2, M3, M4 go through output shaft centerline

(3) See Table A, below, for minimum "M" mounting position required for specific screw diameter and reducer size

Table A - Screw Conveyor Motor Mount Minimum "M" Mounting Positions (1)

Nominal Screw Dia	Trough Height Dim	Minimum Mounting Position							
		TA0107L	TA1107H	TA2115H	TA3203H	TA4207H	TA5215H	TA6307H	TA7315H
6	7.00	M2	M3	M2	M2	M2	M1	M1	M1
9	9.00	M3	M4	M3	M3	M2	M2	M2	M1
12	10.00	M4	M4	M3	M3	M2	M2	M2	M1
14	11.00	M4	M4	M4	M3	M3	M2	M2	M2
16	11.50	M4	***	M4	M4	M3	M2	M2	M2
18	12.13	***	***	M4	M4	M3	M3	M2	M2
20	13.50	***	***	M4	M4	M3	M3	M3	M2
24	16.50	***	***	***	***	M4	M3	M3	M3

(1) For U Or Flared Trough Ends Per CEMA 300-014

FEATURES/BENEFITS PAGE G1-3	NOMENCLATURE PAGE G1-8	SELECTION PAGE G1-12	RELATED PRODUCTS PAGE G1-123
--------------------------------	---------------------------	-------------------------	---------------------------------

SELECTION/DIMENSIONS



TORQUE-ARM II Shaft Mount Speed Reducers

TAPER BUSHED REDUCERS - TA5215H, SINGLE AND DOUBLE REDUCTION

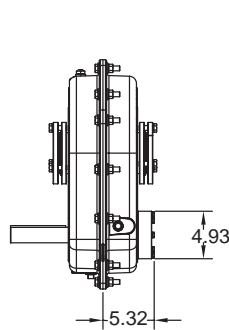
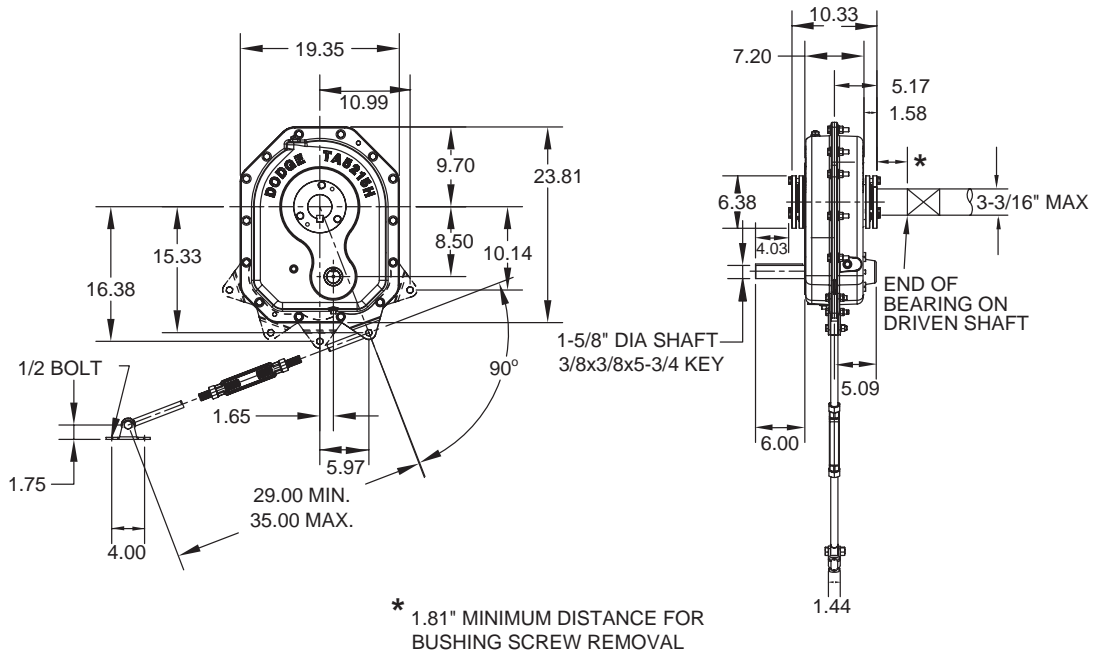

REDUCER WITH BACKSTOP

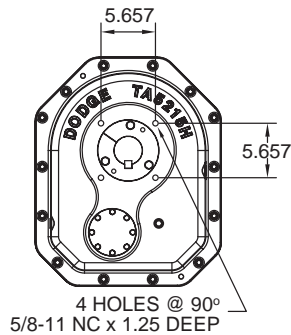

FLANGE MOUNTING DIMENSIONS

FEATURES/BENEFITS PAGE G1-3	NOMENCLATURE PAGE G1-8	SELECTION PAGE G1-12	RELATED PRODUCTS PAGE G1-123
--------------------------------	---------------------------	-------------------------	---------------------------------



TORQUE-ARM II Shaft Mount Speed Reducers

TAPER BUSHED REDUCERS - TA5215H, SINGLE AND DOUBLE REDUCTION

TA5215H Taper Bushed Reducers ⁽¹⁾ ■

Reducer Size	Part Number	AGMA Code	Actual Ratio	Weight lbs.
TA5215H05	905004	215S05	5.11	259.8
TA5215H09	905003	215D09	9.18	274.4
TA5215H15	905002	215D15	14.92	273.9
TA5215H25	905001	215D25	25.00	272.9
TA5215H40	905000	215D40	38.91	272.1

(1) Reducers are supplied from stock ready for vertical mounting and for flange mounting. Rod assembly is not included with reducer. Order as a separate part number.

■ - See page G1-124 for Maximum Bore Straight Bore TA II Reducers

TA5215H Accessories

Description	Part Number	Weight lbs.
TA5215RA Rod Assembly ⁽¹⁾	905109	11.0
TA5215BS Backstop Assembly ⁽²⁾	905102	8.3
TA521BS 40:1 Backstop Assembly ⁽²⁾	905103	8.3
TA5215MM Motor Mount Assembly (182-365T) ⁽³⁾	905090	124.8
TA5215BG Belt Guard - Pos. B (182-365T)	905096	101.5
TA5215BG Belt Guard - Pos. C (182-365T) ⁽⁴⁾	905097	105.5
TA5215CF Cooling Fan Assembly ●	905106	3.0
TA4-TA12 Vertical Breather Kit	904112	3.0
Filter Breather Kit	430049	0.2

(2) See page G1-130 for input shaft speed necessary for backstop sprag lift-off.

(3) Motor Mount will fit NEMA and IEC frame motors; however hardware are inch dimensions.

(4) Use Position C belt guard for TA II reducer in screw conveyor drive applications.

● See page G1-122 for cooling fan dimensions

TA5215H Tapered Bushing Kits ⁽⁵⁾ (6)

Bushing Size Standard Shaft Bushing Kit	Part Number (7)	Weight lbs.	Shaft Keyseat Required (9) (10)	Bushing Size	Part Number	Weight lbs.	Shaft Keyseat Required ⁽⁹⁾ (10)
				Short Shaft Bushing Kit ⁽⁸⁾			
TA5215TB x 3-3/16	905020	13.7	3/4 x 3/8 x 10.34	---	---	---	---
TA5215TB x 3	905021	15.1	3/4 x 3/8 x 10.34	---	---	---	---
TA5215TB x 2-15/16 ▲	905022	15.6	3/4 x 3/8 x 10.34	TA5215TBS x 2-15/16	905033	16.2	3/4 x 3/8 x 6.36
TA5215TB x 2-7/8	905023	16.1	3/4 x 3/8 x 10.34	TA5215TBS x 2-7/8	905034	16.9	3/4 x 3/8 x 6.36
TA5215TB x 2-11/16	905024	16.7	5/8 x 5/16 x 10.34	TA5215TBS x 2-11/16	905035	18.1	5/8 x 5/16 x 6.36
TA5215TB x 2-1/2	905025	17.9	5/8 x 5/16 x 10.34	TA5215TBS x 2-1/2	905036	19.7	5/8 x 5/16 x 6.36
TA5215TB x 2-7/16	905026	18.1	5/8 x 5/16 x 10.34	TA5215TBS x 2-7/16	905037	20.1	5/8 x 5/16 x 6.36
TA5215TB x 2-3/8	905027	18.3	5/8 x 5/16 x 10.34	TA5215TBS x 2-3/8	905038	20.5	5/8 x 5/16 x 6.36
TA5215TB x 2-1/4	905028	18.9	1/2 x 1/4 x 10.34	TA5215TBS x 2-1/4	905039	21.4	1/2 x 1/4 x 6.36
TA5215TB x 2-3/16	905029	19.1	1/2 x 1/4 x 10.34	TA5215TBS x 2-3/16	905040	21.8	1/2 x 1/4 x 6.36
TA5215TB x 2-1/8	905030	19.3	1/2 x 1/4 x 10.34	TA5215TBS x 2-1/8	905041	22.2	1/2 x 1/4 x 6.36
TA5215TB x 2	905031	19.9	1/2 x 1/4 x 10.34	TA5215TBS x 2	905042	23.0	1/2 x 1/4 x 6.36
TA5215TB x 1-15/16	905032	20.1	1/2 x 1/4 x 10.34	TA5215TBS x 1-15/16	905043	23.4	1/2 x 1/4 x 6.36

▲ AGMA maximum bore size

(5) Bushing kit required to mount TA II reducer to driven shaft

(6) Bushing kit is not required to mount TA II reducer on SCS Drive Shaft in a screw conveyor application

(7) Standard Shaft Bushing Kit includes two standard bushings with back-up plates and snap rings, hardware and key

(8) Short Shaft Bushing Kit includes one standard bushing; one long bushing with insertable wedge; two backup plates with snap rings; hardware and key. This is an optional bushing for after market, short shaft mounting.

(9) Minimum keyseat and shaft length required to mount reducer with bushing kit

(10) Always check the driven shaft and key for strength

FEATURES/BENEFITS PAGE G1-3	NOMENCLATURE PAGE G1-8	SELECTION PAGE G1-12	RELATED PRODUCTS PAGE G1-123
--------------------------------	---------------------------	-------------------------	---------------------------------

SELECTION/DIMENSIONS



TORQUE-ARM II Shaft Mount Speed Reducers SCREW CONVEYOR DRIVE - TA5215H, SINGLE AND DOUBLE REDUCTION

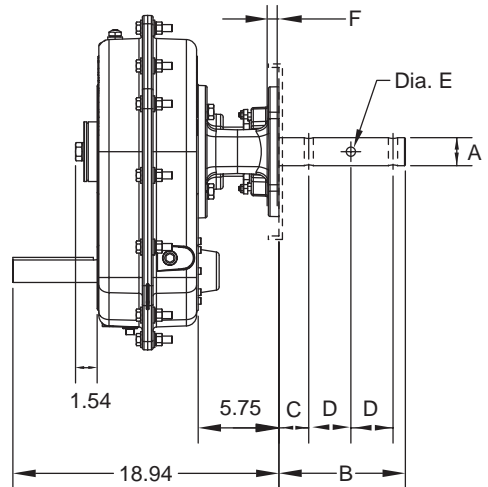
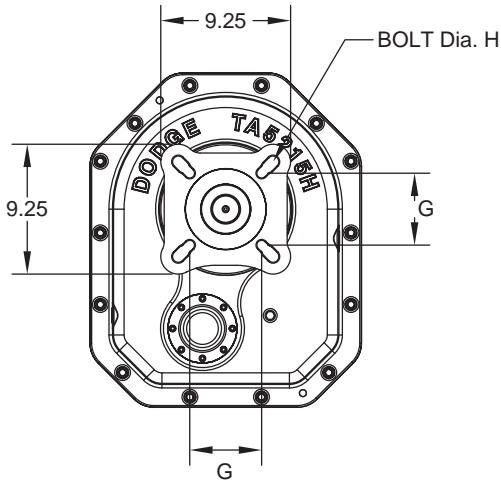

FEATURES/BENEFITS PAGE G1-3	NOMENCLATURE PAGE G1-8	SELECTION PAGE G1-12	RELATED PRODUCTS PAGE G1-123
--------------------------------	---------------------------	-------------------------	---------------------------------



TORQUE-ARM II Shaft Mount Speed Reducers SCREW CONVEYOR DRIVE - TA5215H, SINGLE AND DOUBLE REDUCTION

TA5215H Screw Conveyor Drive Dimensions

Screw Dia	Drive Shaft Dia A	Dimensions						
		B	C	D	Hole Dia E	F	G	Bolt Dia H
9, 12	2	9.00	2.13	3.00	21/32	0.75	5.13	5/8
12, 14	2-7/16	9.69	2.75	3.00	21/32	0.75	5.63	5/8
12, 14, 16, 18, 20	3	9.88	2.88	3.00	25/32	0.75	6.00	3/4
18, 20, 24	3-7/16	13.13	3.88	4.00	29/32	0.75	6.75	3/4

TA5215H Accessories for Screw Conveyor Drives (1) (4) (5)

Description	Part Number	Weight lbs.
TA5215SCA Adapter & Hardware Kit ⁽²⁾	905070	38.4
TA5215SCP Adjustable Packing Kit ⁽³⁾	905071	2.1
TA5215SCS x 2 Drive Shaft	905073	39.0
TA5215SCS x 2-7/16 Drive Shaft	905074	43.6
TA5215SCS x 3 Drive Shaft	905075	50.0
TA5215SCS x 3-7/16 Drive Shaft	905076	63.9
TA5215SCS x 2 Stainless Steel Drive Shaft	905081	39.0
TA5215SCS x 2-7/16 Stainless Steel Drive Shaft	905082	43.6
TA5215SCS x 3 Stainless Steel Drive Shaft	905083	50.0
TA5215SCS x 3 -7/16 Stainless Steel Drive Shaft	905084	63.9

- (1) See page G1-77 for Belt Guard for Screw Conveyor Drive applications.
- (2) SCA Adapter & Hardware Kit includes adapter, mounting wedge, keeper plate, key, seals and hardware.
- (3) SCP Adjustable Packing Kit consists of flange, mounting hardware and braided packing seals.
- (4) SCS Drive Shaft is a shaft only. Mounting hardware is stocked with the adapter & hardware kit.
- (5) A complete TA II Screw Conveyor Drive includes a TA II Reducer, SCA Adapter & Hardware Kit, and SCS Drive Shaft. The SCP Adjustable Packing Kit is an optional accessory.

FEATURES/BENEFITS PAGE G1-3	NOMENCLATURE PAGE G1-8	SELECTION PAGE G1-12	RELATED PRODUCTS PAGE G1-123
--------------------------------	---------------------------	-------------------------	---------------------------------



SELECTION/DIMENSIONS

TORQUE-ARM II Shaft Mount Speed Reducers MOTOR MOUNT DIMENSIONS - TA5215H, POSITION B & D

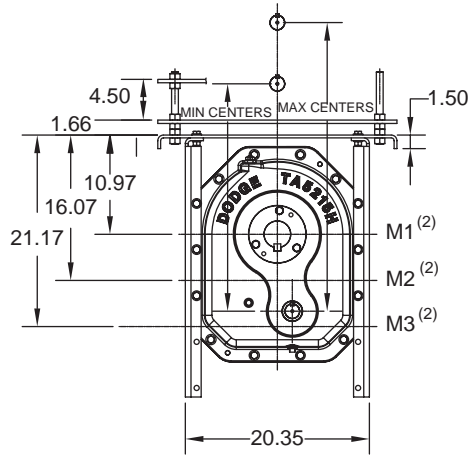

POSITION B

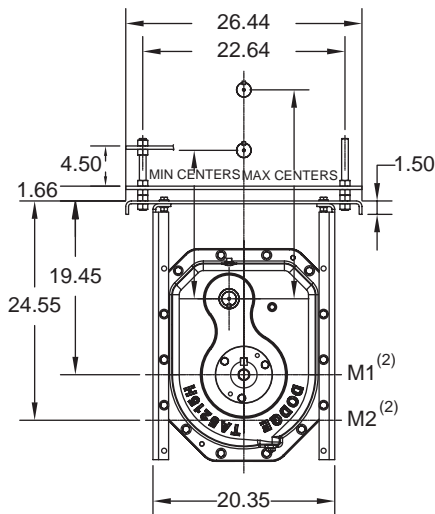

POSITION D

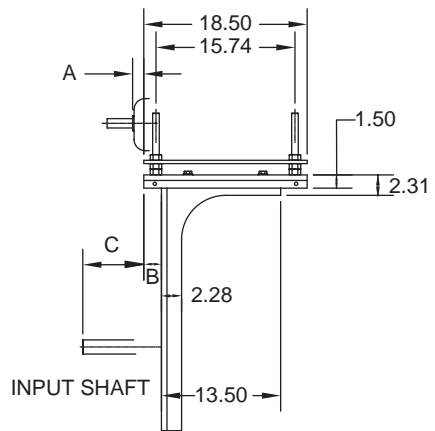

FEATURES/BENEFITS PAGE G1-3	NOMENCLATURE PAGE G1-8	SELECTION PAGE G1-12	RELATED PRODUCTS PAGE G1-123
--------------------------------	---------------------------	-------------------------	---------------------------------

SELECTION/DIMENSIONS



TORQUE-ARM II Shaft Mount Speed Reducers

MOTOR MOUNT DIMENSIONS - TA5215H, POSITION B & D ⁽¹⁾

Mounting	Lateral Adjustment				Motor Mount Height (2)	Motor Frame								
						182T & 184T			213T & 215T			254T & 256T		
	B Min	B Max	C Min	C Max		A	Centers		A	Centers		A	Centers	
							Min	Max		Min	Max		Min	Max
Position B	-0.21	4.21	4.70	9.12	M1	1.37	26.2	30.3	1.55	26.9	31.1	1.56	27.9	32.1
					M2		31.2	35.3		31.9	36.1		32.9	37.1
					M3		36.2	40.3		36.9	41.1		37.9	42.1
Position D	-0.21	4.21	4.70	9.12	M1	1.37	17.7	21.8	1.55	18.4	22.6	1.56	19.4	23.6
					M2		22.7	26.8		23.4	27.6		24.4	28.6

Mounting	Lateral Adjustment				Motor Mount Height (2)	Motor Frame								
						284T & 286T			324T & 326T			364T & 365T		
	B Min	B Max	C Min	C Max		A	Centers		A	Centers		A	Centers	
							Min	Max		Min	Max		Min	Max
Position B	-0.21	4.21	4.70	9.12	M1	1.16	28.7	32.8	0.38	29.7	33.8	1.01	30.7	34.8
					M2		33.7	37.8		34.7	38.8		35.7	39.8
					M3		38.7	42.8		39.7	43.8		40.7	44.8
Position D	-0.21	4.21	4.70	9.12	M1	1.16	20.2	24.3	0.38	21.2	25.3	1.01	22.2	26.3
					M2		25.2	29.3		26.2	30.3		27.2	31.3

Notes:

Minimum centers contains 0.5" to allow for belt assembly

- (1) Motor mount will fit NEMA and IEC frame motors; hardware are inch dimensions
- (2) M1, M2, M3 go through output shaft centerline

FEATURES/BENEFITS PAGE G1-3	NOMENCLATURE PAGE G1-8	SELECTION PAGE G1-12	RELATED PRODUCTS PAGE G1-123
--------------------------------	---------------------------	-------------------------	---------------------------------

SELECTION/DIMENSIONS



TORQUE-ARM II Shaft Mount Speed Reducers MOTOR MOUNT DIMENSIONS - TA5215H, POSITION A & C

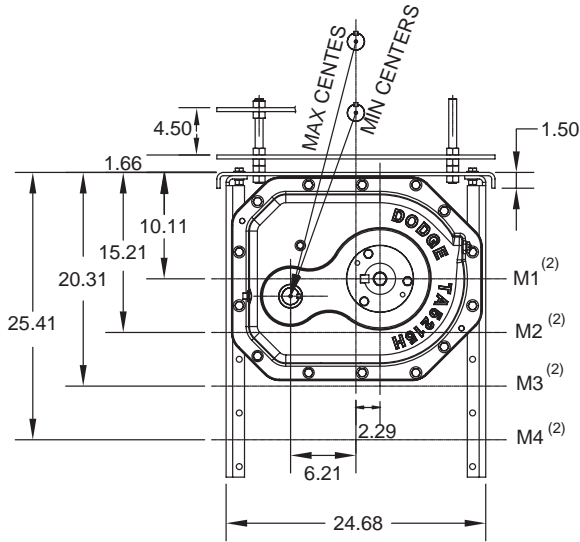

POSITION A

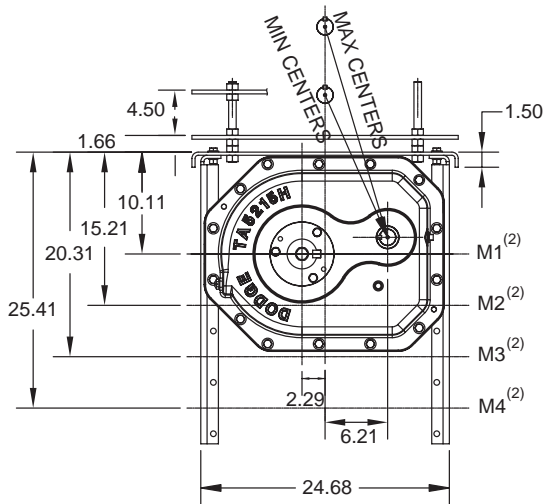

POSITION C

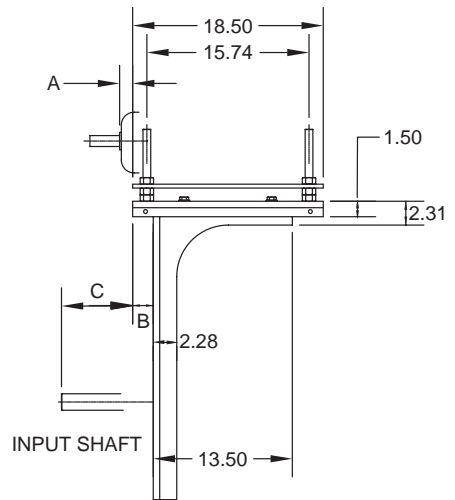

<p>FEATURES/BENEFITS PAGE G1-3</p>	<p>NOMENCLATURE PAGE G1-8</p>	<p>SELECTION PAGE G1-12</p>	<p>RELATED PRODUCTS PAGE G1-123</p>
--	-----------------------------------	---------------------------------	---

SELECTION/DIMENSIONS



TORQUE-ARM II Shaft Mount Speed Reducers

MOTOR MOUNT DIMENSIONS - TA5215H, POSITION A & C (1) (3)

Mounting	Lateral Adjustment				Motor Mount Height (2)	Motor Frame									
						182T & 184T		213T & 215T		254T & 256T					
	B Min	B Max	C Min	C Max		A	Centers		A	Centers		A	Centers		
Position A	-0.21	4.21	5.77	10.19	M1	1.37	19.5	23.4	1.55	20.2	24.1	1.56	21.1	25.1	
							M2	24.2		28.3	25.0		29.0	25.9	30.0
							M3	29.1		33.2	29.8		33.9	30.8	34.9
							M4	34.0		38.1	34.7		38.8	35.7	39.8
Position C	-0.21	4.21	5.77	10.19	M1	1.37	16.4	20.3	1.55	17.1	21.0	1.56	18.0	21.9	
							M2	21.1		25.1	21.8		25.8	22.8	26.8
							M3	25.9		29.9	26.6		30.7	27.6	31.6
							M4	30.8		34.8	31.5		35.6	32.5	36.6

Mounting	Lateral Adjustment				Motor Mount Height (2)	Motor Frame									
						284T & 286T		324T & 326T		364T & 365T					
	B Min	B Max	C Min	C Max		A	Centers		A	Centers		A	Centers		
Position A	-0.21	4.21	5.77	10.19	M1	1.16	21.8	25.8	0.38	22.8	26.8	1.01	23.8	27.8	
							M2	26.7		30.7	27.6		31.7	28.6	32.7
							M3	31.5		35.6	32.5		36.6	33.5	37.6
							M4	36.5		40.6	37.4		41.5	38.4	42.5
Position C	-0.21	4.21	5.77	10.19	M1	1.16	18.7	22.6	0.38	19.7	23.6	1.01	20.6	24.6	
							M2	23.5		27.5	24.4		28.5	25.4	29.4
							M3	28.3		32.4	29.3		33.4	30.3	34.3
							M4	33.2		37.3	34.2		38.3	35.2	39.3

Notes:

Minimum centers contains 0.5" to allow for belt assembly

- (1) Motor mount will fit NEMA and IEC frame motors; hardware are inch dimensions
- (2) M1, M2, M3, M4 go through output shaft centerline
- (3) See Table A, below, for minimum "M" mounting position required for specific screw diameter and reducer size

Table A - Screw Conveyor Motor Mount Minimum "M" Mounting Positions (1)

Nominal Screw Dia	Trough Height Dim	Minimum Mounting Position							
		TA0107L	TA1107H	TA2115H	TA3203H	TA4207H	TA5215H	TA6307H	TA7315H
6	7.00	M2	M3	M2	M2	M2	M1	M1	M1
9	9.00	M3	M4	M3	M3	M2	M2	M2	M1
12	10.00	M4	M4	M3	M3	M2	M2	M2	M1
14	11.00	M4	M4	M4	M3	M3	M2	M2	M2
16	11.50	M4	***	M4	M4	M3	M2	M2	M2
18	12.13	***	***	M4	M4	M3	M3	M2	M2
20	13.50	***	***	M4	M4	M3	M3	M3	M2
24	16.50	***	***	***	***	M4	M3	M3	M3

(1) For U Or Flared Trough Ends Per CEMA 300-014

FEATURES/BENEFITS PAGE G1-3	NOMENCLATURE PAGE G1-8	SELECTION PAGE G1-12	RELATED PRODUCTS PAGE G1-123
--------------------------------	---------------------------	-------------------------	---------------------------------

SELECTION/DIMENSIONS



TORQUE-ARM II Shaft Mount Speed Reducers

TAPER BUSHED REDUCERS - TA6307H, SINGLE AND DOUBLE REDUCTION

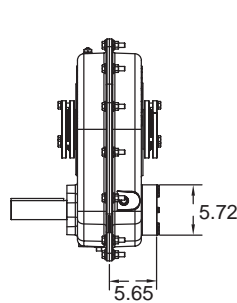
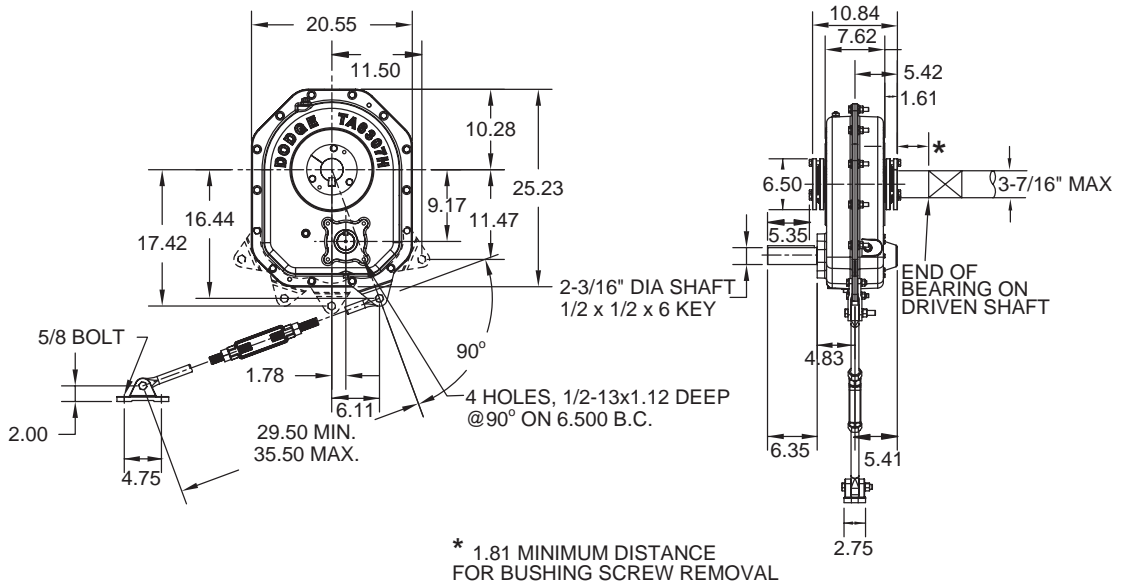

REDUCER WITH BACKSTOP

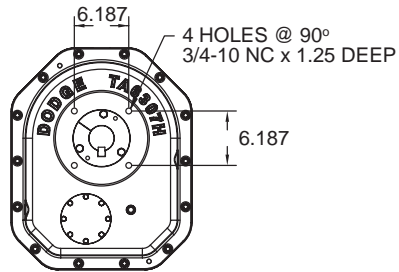

FLANGE MOUNTING DIMENSIONS

FEATURES/BENEFITS PAGE G1-3	NOMENCLATURE PAGE G1-8	SELECTION PAGE G1-12	RELATED PRODUCTS PAGE G1-123
--------------------------------	---------------------------	-------------------------	---------------------------------



TORQUE-ARM II Shaft Mount Speed Reducers TAPER BUSHED REDUCERS - TA6307H, SINGLE AND DOUBLE REDUCTION

TA6307H Taper Bushed Reducers ⁽¹⁾ ■

Reducer Size	Part Number	AGMA Code	Actual Ratio	Weight lbs.
TA6307H05	906004	307S05	4.94	316.0
TA6307H09	906003	307D09	9.22	334.0
TA6307H15	906002	307D15	15.45	333.0
TA6307H25	906001	307D25	24.87	331.0
TA6307H40	906000	307D40	38.32	330.0

(1) Reducers are supplied from stock ready for vertical mounting and for flange mounting. Rod assembly is not included with reducer. Order as a separate part number.

■ See page G1-124 for Maximum Bore Straight Bore TA II Reducers

TA6307H Accessories

Description	Part Number	Weight lbs.
TA6307RA Rod Assembly ⁽¹⁾	906109	19.9
TA6307BS Backstop Assembly ⁽²⁾	906102	11.1
TA6307BS 25:1 & 40:1 Backstop Assembly ⁽²⁾	906103	11.1
TA6307MM Motor Mount Assembly (182-405T) ⁽³⁾	906090	156.7
TA6307BG Belt Guard - Pos. B (182-405T)	906096	121.2
TA6307BG Belt Guard - Pos. C (182-405T) ⁽⁴⁾	906097	129.4
TA6307CF Cooling Fan Assembly ●	906106	10.0
TA4-TA12 Vertical Breather Kit	904112	3.0
Filter Breather Kit	430049	0.2

(2) See page G1-130 for input shaft speed necessary for backstop sprag lift-off

(3) Motor Mount will fit NEMA and IEC frame motors; however hardware are inch dimensions

(4) Use Position-C belt guard for TA II reducer in screw conveyor drive applications

● See page G1-122 for cooling fan dimensions

TA6307H Tapered Bushing Kits ⁽⁵⁾ (6)

Bushing Size Standard Shaft Bushing Kit	Part Number (7)	Weight lbs.	Shaft Keyseat Required (9) (10)	Bushing Size Short Shaft Bushing Kit (8)	Part Number	Weight lbs.	Shaft Keyseat Required (9) (10)
TA6307TB x 3-7/16 ▲	906020	16.7	7/8 x 7/16 x 10.82	TA6307TBS x 3-7/16	906031	16.5	7/8 x 7/16 x 6.72
TA6307TB x 3-3/16	906021	17.7	3/4 x 3/8 x 10.82	TA6307TBS x 3-3/16	906032	19.0	3/4 x 3/8 x 6.72
TA6307TB x 3	906022	19.1	3/4 x 3/8 x 10.82	TA6307TBS x 3	906033	20.9	3/4 x 3/8 x 6.72
TA6307TB x 2-15/16	906023	19.6	3/4 x 3/8 x 10.82	TA6307TBS x 2-15/16	906034	21.6	3/4 x 3/8 x 6.72
TA6307TB x 2-7/8	906024	20.1	3/4 x 3/8 x 10.82	TA6307TBS x 2-7/8	906035	22.3	3/4 x 3/8 x 6.72
TA6307TB x 2-11/16	906025	20.9	5/8 x 5/16 x 10.82	TA6307TBS x 2-11/16	906036	23.7	5/8 x 5/16 x 6.72
TA6307TB x 2-1/2	906026	22.1	5/8 x 5/16 x 10.82	TA6307TBS x 2-1/2	906037	25.3	5/8 x 5/16 x 6.72
TA6307TB x 2-7/16	906027	22.3	5/8 x 5/16 x 10.82	TA6307TBS x 2-7/16	906038	25.8	5/8 x 5/16 x 6.72
TA6307TB x 2-3/8	906028	22.7	5/8 x 5/16 x 10.82	TA6307TBS x 2-3/8	906039	26.3	5/8 x 5/16 x 6.72
TA6307TB x 2-1/4	906029	23.1	1/2 x 1/4 x 10.82	TA6307TBS x 2-1/4	906040	26.7	1/2 x 1/4 x 6.72
TA6307TB x 2-3/16	906030	23.3	1/2 x 1/4 x 10.82	TA6307TBS x 2-3/16	906041	27.5	1/2 x 1/4 x 6.72

▲ AGMA maximum bore size

(5) Bushing kit required to mount TA II reducer to driven shaft

(6) Bushing Kit is not required to mount TA II reducer on SCS Drive Shaft in a screw conveyor application

(7) Standard Shaft Bushing Kit includes two standard bushings with backup plates and snap rings; hardware and one key

(8) Short Shaft Bushing Kit includes one standard bushing; one long bushing with mounting wedge; two backup plates with snap rings; hardware and one key. This is an optional bushing for after market, short shaft mounting.

(9) Minimum keyseat and shaft length required to mount reducer with bushing kit

(10) Always check the driven shaft and key for strength

FEATURES/BENEFITS PAGE G1-3	NOMENCLATURE PAGE G1-8	SELECTION PAGE G1-12	RELATED PRODUCTS PAGE G1-123
--------------------------------	---------------------------	-------------------------	---------------------------------

SELECTION/DIMENSIONS



TORQUE-ARM II Shaft Mount Speed Reducers SCREW CONVEYOR DRIVE - TA6307H, SINGLE AND DOUBLE REDUCTION

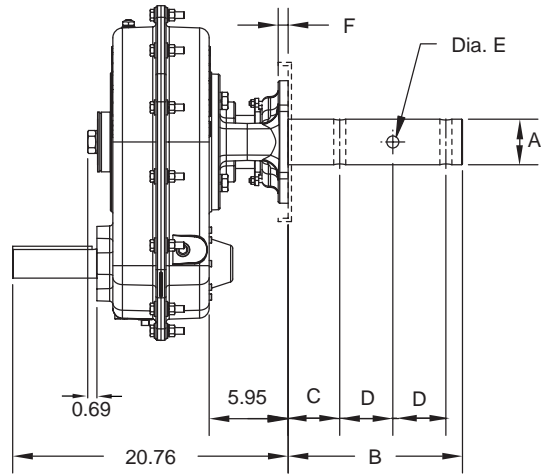
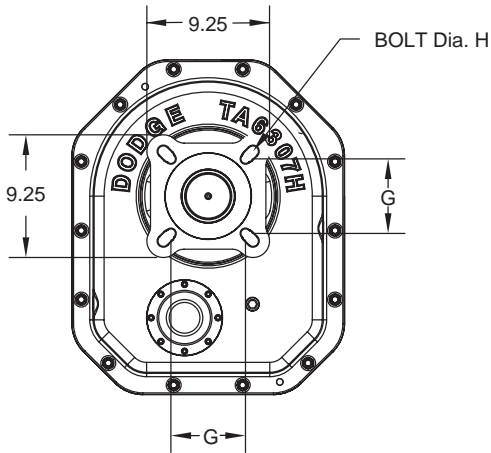

FEATURES/BENEFITS PAGE G1-3	NOMENCLATURE PAGE G1-8	SELECTION PAGE G1-12	RELATED PRODUCTS PAGE G1-123
--------------------------------	---------------------------	-------------------------	---------------------------------



TORQUE-ARM II Shaft Mount Speed Reducers SCREW CONVEYOR DRIVE - TA6307H, SINGLE AND DOUBLE REDUCTION

TA6307H Screw Conveyor Drive Dimensions

Screw Dia	Drive Shaft Dia A	Dimensions						
		B	C	D	Hole Dia E	F	G	Bolt Dia H
12, 14	2-7/16	9.69	2.75	3.00	21/32	0.75	5.63	5/8
12, 14, 16, 18, 20	3	9.88	2.88	3.00	25/32	0.75	6.00	3/4
18, 20, 24	3-7/16	13.13	3.88	4.00	29/32	0.75	6.75	3/4

TA6307H Accessories for Screw Conveyor Drives (1) (4) (5)

Description	Part Number	Weight lbs.
TA6307SCA Adapter & Hardware Kit ⁽²⁾	906070	40.0
TA6307SCP Adjustable Packing Kit ⁽³⁾	906071	2.4
TA6307SCS x 2-7/16 Drive Shaft	906074	54.6
TA6307SCS x 3 Drive Shaft	906075	61.0
TA6307SCS x 3-7/16 Drive Shaft	906076	74.9
TA6307SCS x 2-7/16 Stainless Steel Drive Shaft	906082	54.6
TA6307SCS x 3 Stainless Steel Drive Shaft	906083	61.0
TA6307SCS x 3-7/16 Stainless Steel Drive Shaft	906084	74.9

- (1) See page G1-85 for Belt Guard for Screw Conveyor Drive applications.
- (2) SCA Adapter & Hardware Kit includes adapter, mounting wedge, keeper plate, key, seals and hardware.
- (3) SCP Adjustable Packing Kit consists of flange, mounting hardware and braided packing seals.
- (4) SCS Drive Shaft is a shaft only. Mounting hardware is stocked with the adapter & hardware kit.
- (5) A complete TA II Screw Conveyor Drive includes a TA II Reducer, SCA Adapter & Hardware Kit, and SCS Drive Shaft. The SCP Adjustable Packing Kit is an optional accessory.

FEATURES/BENEFITS PAGE G1-3	NOMENCLATURE PAGE G1-8	SELECTION PAGE G1-12	RELATED PRODUCTS PAGE G1-123
--------------------------------	---------------------------	-------------------------	---------------------------------

SELECTION/DIMENSIONS



TORQUE-ARM II Shaft Mount Speed Reducers MOTOR MOUNT DIMENSIONS - TA6307H, POSITION B & D

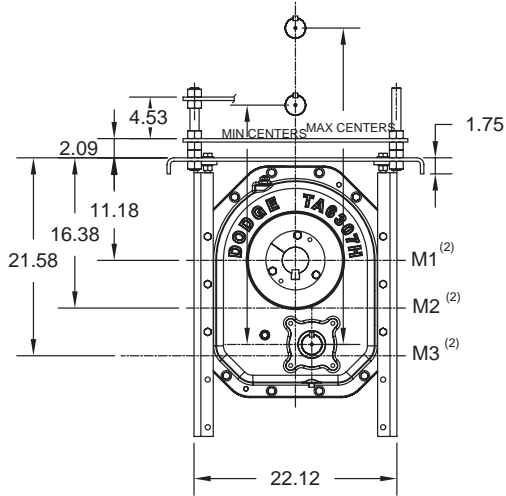

POSITION B

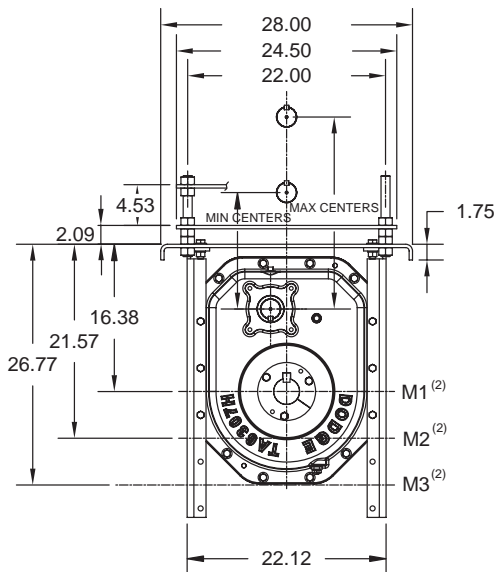

POSITION D

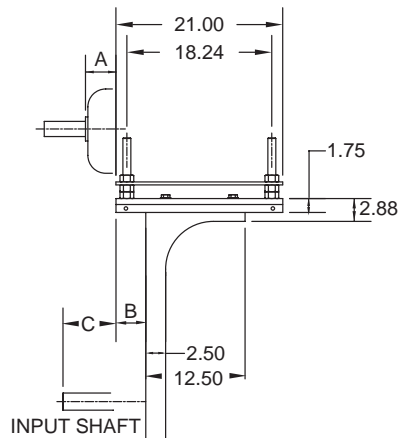

<p>FEATURES/BENEFITS PAGE G1-3</p>	<p>NOMENCLATURE PAGE G1-8</p>	<p>SELECTION PAGE G1-12</p>	<p>RELATED PRODUCTS PAGE G1-123</p>
--	-----------------------------------	---------------------------------	---

SELECTION/DIMENSIONS



TORQUE-ARM II Shaft Mount Speed Reducers

MOTOR MOUNT DIMENSIONS - TA6307H, POSITION B & D ⁽¹⁾

Mounting	Lateral Adjustment				Motor Mount Height (2)	Motor Frame											
						182T & 184T			213T & 215T			254T & 256T			284T & 286T		
	B Min	B Max	C Min	C Max		A	Centers		A	Centers		A	Centers		A	Centers	
							Min	Max		Min	Max		Min	Max		Min	Max
Position B	1.59	5.91	4.51	8.83	M1	1.37	27.5	31.5	1.55	28.2	32.3	1.56	29.2	33.3	1.16	30.0	34.0
					M2		32.7	36.7		33.4	37.5		34.4	38.5		35.2	39.2
					M3		37.9	41.9		38.6	42.7		39.6	43.7		40.4	44.4
Position D	1.59	5.91	4.51	8.83	M1	1.37	14.4	18.4	1.55	15.2	19.2	1.56	16.1	20.2	1.16	16.9	20.9
					M2		19.6	23.6		20.3	24.3		21.3	25.3		22.1	26.1
					M3		24.8	28.8		25.5	29.5		26.5	30.5		27.3	31.3

Mounting	Lateral Adjustment				Motor Mount Height (2)	Motor Frame											
						324T & 326T			364T & 365T			404T & 405T					
	B Min	B Max	C Min	C Max		A	Centers		A	Centers		A	Centers				
							Min	Max		Min	Max		Min	Max			
Position B	1.59	5.91	4.51	8.83	M1	0.38	31.0	35.0	1.01	32.0	36.0	0.75	33.0	37.0			
					M2		36.2	40.2		37.2	41.2		38.2	42.2			
					M3		41.4	45.4		42.4	46.4		43.4	47.4			
Position D	1.59	5.91	4.51	8.83	M1	0.38	17.9	21.9	1.01	18.9	22.9	0.75	19.9	23.9			
					M2		23.1	27.1		24.1	28.1		25.1	29.1			
					M3		28.3	32.3		29.3	33.3		30.2	34.3			

Notes:

Minimum centers contains 0.5" to allow for belt assembly

Motor mount will fit NEMA and IEC frame motors; hardware are inch dimensions

M1, M2, M3 go through output shaft centerline

FEATURES/BENEFITS PAGE G1-3	NOMENCLATURE PAGE G1-8	SELECTION PAGE G1-12	RELATED PRODUCTS PAGE G1-123
--------------------------------	---------------------------	-------------------------	---------------------------------



SELECTION/DIMENSIONS

TORQUE-ARM II Shaft Mount Speed Reducers MOTOR MOUNT DIMENSIONS - TA6307H, POSITION A & C

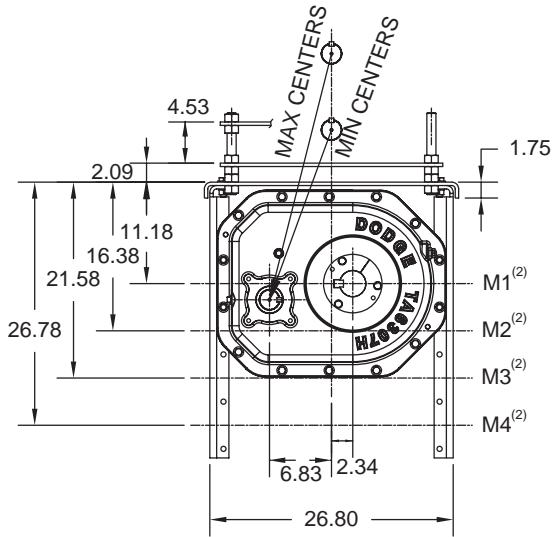

POSITION A

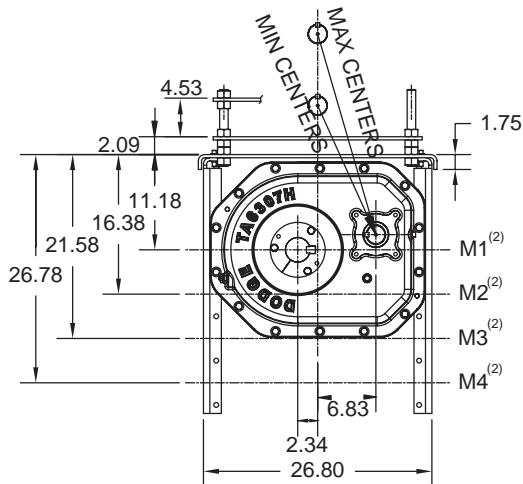

POSITION C

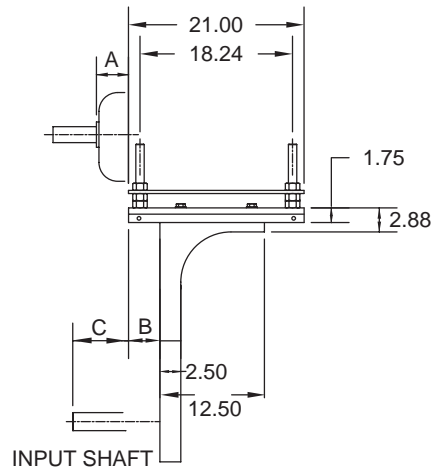

<p>FEATURES/BENEFITS PAGE G1-3</p>	<p>NOMENCLATURE PAGE G1-8</p>	<p>SELECTION PAGE G1-12</p>	<p>RELATED PRODUCTS PAGE G1-123</p>
--	-----------------------------------	---------------------------------	---



TORQUE-ARM II Shaft Mount Speed Reducers

MOTOR MOUNT DIMENSIONS - TA6307H, POSITION A & C (1) (3)

Mounting	Lateral Adjustment				Motor Mount Height (2)	Motor Frame										
						182T & 184T		213T & 215T		254T & 256T		284T & 286T				
	B Min	B Max	C Min	C Max		A	Centers		A	Centers		A	Centers			
							Min	Max		Min	Max		Min	Max	Min	Max
Position A	1.59	5.91	5.65	9.97	M1	21.2	25.0	1.55	21.9	25.8	1.56	22.9	26.7	1.16	23.6	27.4
					M2	26.2	30.1		26.9	30.8		27.9	31.8		28.6	32.5
					M3	31.2	35.1		32.0	35.9		32.9	36.9		33.7	37.6
					M4	36.3	40.3		37.0	41.0		38.0	42.0		38.8	42.7
Position C	1.59	5.91	5.65	9.97	M1	17.9	21.6	1.55	18.6	22.3	1.56	19.5	23.3	1.16	20.2	24.0
					M2	22.8	26.6		23.5	27.3		24.4	28.3		25.2	29.0
					M3	27.8	31.7		28.5	32.4		29.5	33.4		30.2	34.1
					M4	32.8	36.8		33.5	37.5		34.5	38.5		35.3	39.2

Mounting	Lateral Adjustment				Motor Mount Height (2)	Motor Frame								
						324T & 326T		364T & 365T		404T & 405T				
	B Min	B Max	C Min	C Max		A	Centers		A	Centers		A	Centers	
							Min	Max		Min	Max		Min	Max
Position A	1.59	5.91	5.65	9.97	M1	0.38	24.5	28.4	1.01	25.5	29.4	0.75	26.5	30.4
					M2		29.6	33.5		30.5	34.5		31.5	35.4
					M3		34.6	38.6		35.6	39.6		36.6	40.6
					M4		39.7	43.7		40.7	44.7		41.7	45.7
Position C	1.59	5.91	5.65	9.97	M1	0.38	21.1	25.0	1.01	22.1	25.9	0.75	23.0	26.9
					M2		26.1	30.0		27.1	31.0		28.0	32.0
					M3		31.2	35.1		32.1	36.1		33.1	37.1
					M4		36.2	40.2		37.2	41.2		38.2	42.2

Notes:

Minimum centers contains 0.5" to allow for belt assembly

- (1) Motor mount will fit NEMA and IEC frame motors; hardware are inch dimensions
- (2) M1, M2, M3, M4 go through output shaft centerline
- (3) See Table A, below, for minimum "M" mounting position required for specific screw diameter and reducer size

Table A - Screw Conveyor Motor Mount Minimum "M" Mounting Positions (1)

Nominal Screw Dia	Trough Height Dim	Minimum Mounting Position							
		TA0107L	TA1107H	TA2115H	TA3203H	TA4207H	TA5215H	TA6307H	TA7315H
6	7.00	M2	M3	M2	M2	M2	M1	M1	M1
9	9.00	M3	M4	M3	M3	M2	M2	M2	M1
12	10.00	M4	M4	M3	M3	M2	M2	M2	M1
14	11.00	M4	M4	M4	M3	M3	M2	M2	M2
16	11.50	M4	***	M4	M4	M3	M2	M2	M2
18	12.13	***	***	M4	M4	M3	M3	M2	M2
20	13.50	***	***	M4	M4	M3	M3	M3	M2
24	16.50	***	***	***	***	M4	M3	M3	M3

(1) For U Or Flared Trough Ends Per CEMA 300-014

FEATURES/BENEFITS PAGE G1-3	NOMENCLATURE PAGE G1-8	SELECTION PAGE G1-12	RELATED PRODUCTS PAGE G1-123
--------------------------------	---------------------------	-------------------------	---------------------------------



SELECTION/DIMENSIONS

TORQUE-ARM II Shaft Mount Speed Reducers TAPER BUSHED REDUCERS - TA7315H, SINGLE AND DOUBLE REDUCTION

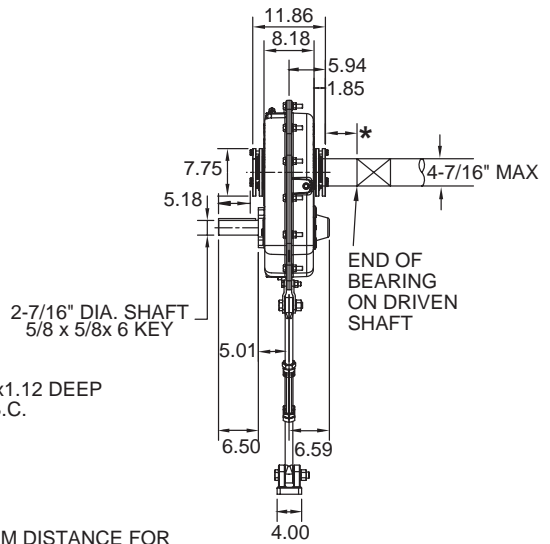
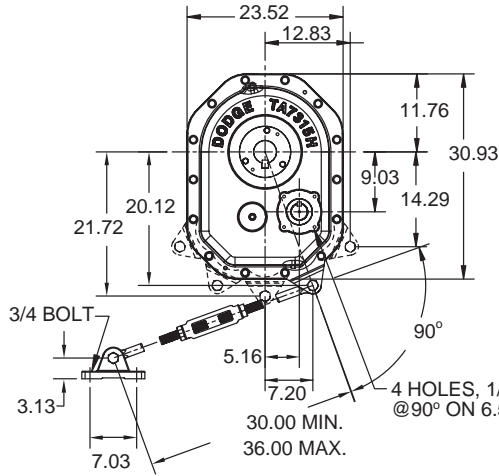

* 2.06" MINIMUM DISTANCE FOR BUSHING SCREW REMOVAL

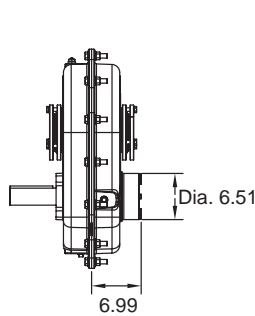

REDUCER WITH BACKSTOP

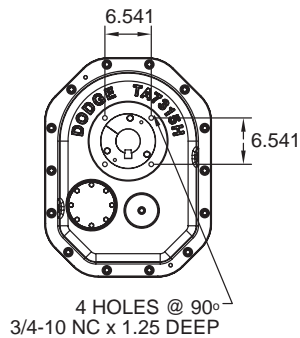

FLANGE MOUNTING DIMENSIONS

FEATURES/BENEFITS PAGE G1-3	NOMENCLATURE PAGE G1-8	SELECTION PAGE G1-12	RELATED PRODUCTS PAGE G1-123
--------------------------------	---------------------------	-------------------------	---------------------------------



TORQUE-ARM II Shaft Mount Speed Reducers TAPER BUSHED REDUCERS - TA7315H, SINGLE AND DOUBLE REDUCTION

TA7315H Taper Bushed Reducers ⁽¹⁾

Reducer Size	Part Number	AGMA Code	Actual Ratio	Weight lbs.
TA7315H05	907004	315S05	5.19	449.0
TA7315H09	907003	315D09	9.72	494.0
TA7315H15	907002	315D15	14.91	493.0
TA7315H25	907001	315D25	24.84	494.0
TA7315H40	907000	315D40	39.66	492.0

- (1) Reducers are supplied from stock ready for vertical mounting and for flange mounting. Rod assembly is not included with reducer. Order as a separate part number.

TA7315H Accessories

Description	Part Number	Weight lbs.
TA7315/8407RA Rod Assembly ⁽¹⁾	907109	43.2
TA7315BS Backstop Assembly ⁽²⁾	907102	20.0
TA7315/9415BS 40:1 Backstop Assembly ⁽²⁾	907103	21.0
TA7315/8407MM Motor Mount Assembly (213-405T) ⁽³⁾	907090	183.3
TA7315/8407BG Belt Guard - Pos. B (213-405T)	907096	147.2
TA7315/8407BG Belt Guard - Pos. C (213-405T) ⁽⁴⁾	907097	152.7
TA7315/8407CF Cooling Fan Assembly ●	907106	10.0
TA4-TA12 Vertical Breather Kit	904112	3.0
Filter Breather Kit	430049	0.2

- (2) See page G1-130 for input shaft speed necessary for backstop sprag lift-off
- (3) Motor Mount will fit NEMA and IEC frame motors; however hardware are inch dimensions
- (4) Use Position-C belt guard for TA II reducer in screw conveyor drive applications
- See page G1-122 for cooling fan dimensions

TA7315H Tapered Bushing Kits ⁽⁵⁾ ⁽⁶⁾

Bushing Size Standard Shaft Bushing Kit	Part Number (7)	Weight lbs.	Shaft Keyseat Required (10)	Bushing Size	Part Number	Weight lbs.	Shaft Keyseat Required (9) (10)
				Short Shaft Bushing Kit (8)			
TA7315TB x 4-7/16	907019	20.5	1 x 1/2 x 11.87	---	---	---	---
TA7315TB x 4-3/16	907021	23.5	1 x 1/2 x 11.87	---	---	---	---
TA7315TB x 3-15/16 ▲	907022	26.3	1 x 1/2 x 11.87	TA7315TBS x 3-15/16	907031	26.7	1 x 1/2 x 7.62
TA7315TB x 3-7/16	907023	30.9	7/8 x 7/16 x 11.87	TA7315TBS x 3-7/16	907032	34.2	7/8 x 7/16 x 7.62
TA7315TB x 3-3/16	907024	32.6	3/4 x 3/8 x 11.87	TA7315TBS x 3-3/16	907033	36.7	3/4 x 3/8 x 7.62
TA7315TB x 3	907025	34.0	3/4 x 3/8 x 11.87	TA7315TBS x 3	907034	38.8	3/4 x 3/8 x 7.62
TA7315TB x 2-15/16	907026	34.6	3/4 x 3/8 x 11.87	TA7315TBS x 2-15/16	907035	39.6	3/4 x 3/8 x 7.62
TA7315TB x 2-7/8	907027	35.0	3/4 x 3/8 x 11.87	TA7315TBS x 2-7/8	907036	40.2	3/4 x 3/8 x 7.62
TA7315TB x 2-11/16	907028	35.8	5/8 x 5/16 x 11.87	TA7315TBS x 2-11/16	907037	41.7	5/8 x 5/16 x 7.62
TA7315TB x 2-1/2	907029	37.2	5/8 x 5/16 x 11.87	TA7315TBS x 2-1/2	907038	43.6	5/8 x 5/16 x 7.62
TA7315TB x 2-7/16	907030	37.4	5/8 x 5/16 x 11.87	TA7315TBS x 2-7/16	907039	44.1	5/8 x 5/16 x 7.62

- ▲ AGMA maximum bore size
- (5) Bushing kit required to mount TA II reducer to driven shaft
- (6) Bushing Kit is not required to mount TA II reducer on SCS Drive Shaft in a screw conveyor application
- (7) Standard Shaft Bushing Kit includes two standard bushings with backup plates and snap rings; hardware and one key
- (8) Short Shaft Bushing Kit includes one standard bushing; one long bushing with mounting wedge; two backup plates with snap rings; hardware and one key. This is an optional bushing for after market, short shaft mounting
- (9) Minimum keyseat and shaft length required to mount reducer with bushing kit
- (10) Always check the driven shaft and key for strength

FEATURES/BENEFITS PAGE G1-3	NOMENCLATURE PAGE G1-8	SELECTION PAGE G1-12	RELATED PRODUCTS PAGE G1-123
--------------------------------	---------------------------	-------------------------	---------------------------------

SELECTION/DIMENSIONS



TORQUE-ARM II Shaft Mount Speed Reducers SCREW CONVEYOR DRIVE - TA7315H, SINGLE AND DOUBLE REDUCTION

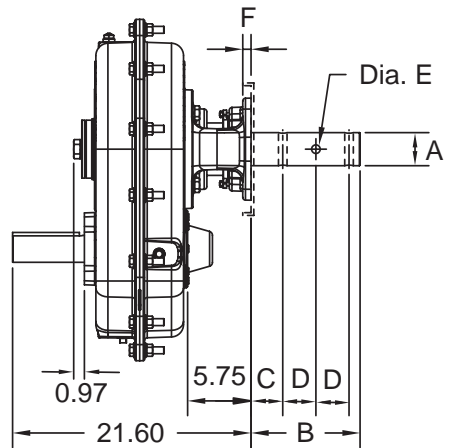
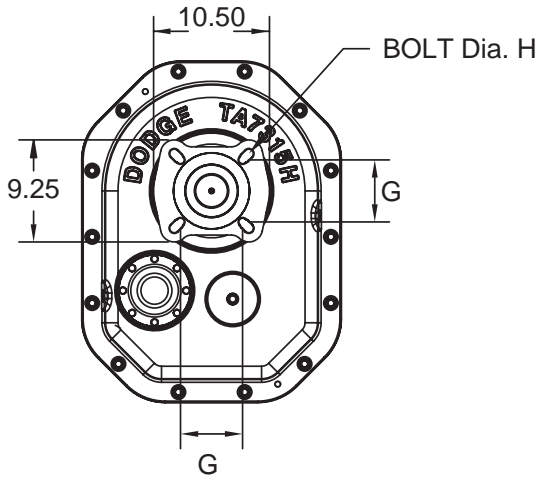

FEATURES/BENEFITS PAGE G1-3	NOMENCLATURE PAGE G1-8	SELECTION PAGE G1-12	RELATED PRODUCTS PAGE G1-123
--------------------------------	---------------------------	-------------------------	---------------------------------



TORQUE-ARM II Shaft Mount Speed Reducers SCREW CONVEYOR DRIVE - TA7315H, SINGLE AND DOUBLE REDUCTION

TA7315H Screw Conveyor Drive Dimensions

Screw Dia	Drive Shaft Dia A	Dimensions						
		B	C	D	Hole Dia E	F	G	Bolt Dia H
12, 14	2-7/16	9.69	2.75	3.00	21/32	0.75	5.63	5/8
12, 14, 16, 18, 20	3	9.88	2.88	3.00	25/32	0.75	6.00	3/4
18, 20, 24	3-7/16	13.13	3.88	4.00	29/32	0.75	6.75	3/4

TA7315H Accessories for Screw Conveyor Drives (1) (4) (5)

Description	Part Number	Weight lbs.
TA7315SCA Adapter & Hardware Kit ⁽²⁾	907070	50.1
TA7315SCP Adjustable Packing Kit ⁽³⁾	907071	2.5
TA7315SCS x 2-7/16 Drive Shaft	907074	77.0
TA7315SCS x 3 Drive Shaft	907075	83.4
TA7315SCS x 3-7/16 Drive Shaft	907076	97.3
TA7315SCS x 2-7/16 Stainless Steel Drive Shaft	907082	77.0
TA7315SCS x 3 Stainless Steel Drive Shaft	907083	83.4
TA7315SCS x 3-7/16 Stainless Steel Drive Shaft	907084	97.3

- (1) See page G1-93 for Belt Guard for Screw Conveyor Drive applications.
- (2) SCA Adapter & Hardware Kit includes adapter, mounting wedge, keeper plate, key, seals and hardware.
- (3) SCP Adjustable Packing Kit consists of flange, mounting hardware and braided packing seals.
- (4) SCS Drive Shaft is a shaft only. Mounting hardware is stocked with the adapter & hardware kit.
- (5) A complete TA II Screw Conveyor Drive includes a TA II Reducer, SCA Adapter & Hardware Kit, and SCS Drive Shaft. The SCP Adjustable Packing kit is an optional accessory

FEATURES/BENEFITS PAGE G1-3	NOMENCLATURE PAGE G1-8	SELECTION PAGE G1-12	RELATED PRODUCTS PAGE G1-123
--------------------------------	---------------------------	-------------------------	---------------------------------

SELECTION/DIMENSIONS



TORQUE-ARM II Shaft Mount Speed Reducers MOTOR MOUNT DIMENSINS - TA7315H, POSITION B & D

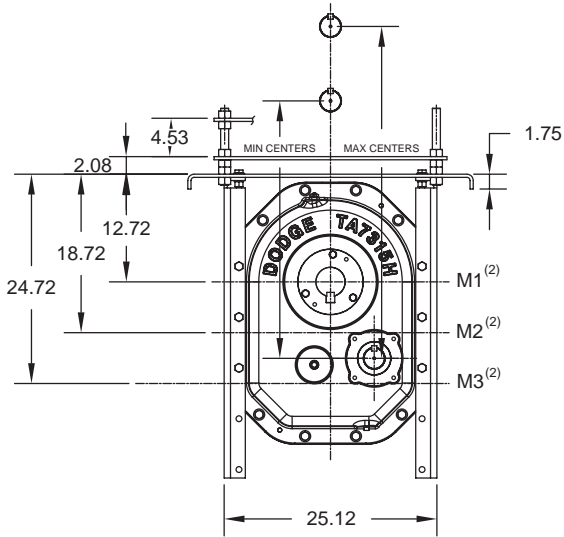

POSITION B

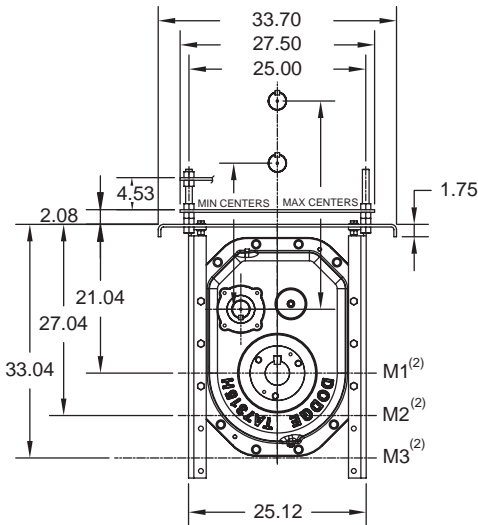
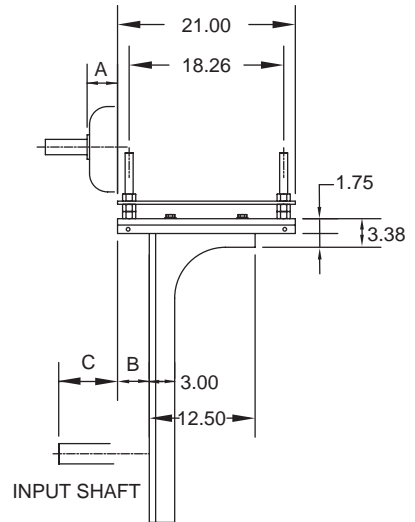

POSITION D

FEATURES/BENEFITS PAGE G1-3	NOMENCLATURE PAGE G1-8	SELECTION PAGE G1-12	RELATED PRODUCTS PAGE G1-123
--------------------------------	---------------------------	-------------------------	---------------------------------

SELECTION/DIMENSIONS



TORQUE-ARM II Shaft Mount Speed Reducers

MOTOR MOUNT DIMENSIONS - TA7315H, POSITION B & D ⁽¹⁾

Mounting	Lateral Adjustment				Motor Mount Height (2)	Motor Frame								
						213T & 215T		254T & 256T		284T & 286T				
	B Min	B Max	C Min	C Max		A	Centers		A	Centers		A	Centers	
							Min	Max		Min	Max		Min	Max
Position B	1.59	5.91	4.78	9.10	M1	1.55	30.0	34.0	1.56	31.0	35.0	1.16	31.8	35.7
					M2		36.0	40.0		37.0	40.9		37.7	41.7
					M3		41.9	45.9		42.9	46.9		43.6	47.6
Position D	1.59	5.91	4.78	9.10	M1	1.55	20.5	24.4	1.56	21.5	25.4	1.16	22.2	26.1
					M2		26.4	30.3		27.4	31.3		28.1	32.0
					M3		32.3	36.3		33.3	37.2		34.0	38.0

Mounting	Lateral Adjustment				Motor Mount Height (2)	Motor Frame								
						324T & 326T		364T & 365T		404T & 405T				
	B Min	B Max	C Min	C Max		A	Centers		A	Centers		A	Centers	
							Min	Max		Min	Max		Min	Max
Position B	1.59	5.91	4.78	9.10	M1	0.38	32.8	36.7	1.01	33.7	37.7	0.75	34.7	38.7
					M2		38.7	42.7		39.7	43.7		40.7	44.7
					M3		44.6	48.6		45.6	49.6		46.6	50.6
Position D	1.59	5.91	4.78	9.10	M1	0.38	23.2	27.1	1.01	24.2	28.1	0.75	25.1	29.1
					M2		29.1	33.0		30.1	34.0		31.0	35.0
					M3		35.0	39.0		36.0	40.0		37.0	41.0

Notes:

Minimum centers contains 0.5" to allow for belt assembly

- (1) Motor mount will fit NEMA and IEC frame motors; hardware are inch dimensions
- (2) M1, M2, M3 go through output shaft centerline

FEATURES/BENEFITS PAGE G1-3	NOMENCLATURE PAGE G1-8	SELECTION PAGE G1-12	RELATED PRODUCTS PAGE G1-123
--------------------------------	---------------------------	-------------------------	---------------------------------



SELECTION/DIMENSIONS

TORQUE-ARM II Shaft Mount Speed Reducers MOTOR MOUNT DIMENSIONS - TA7315H, POSITION A & C

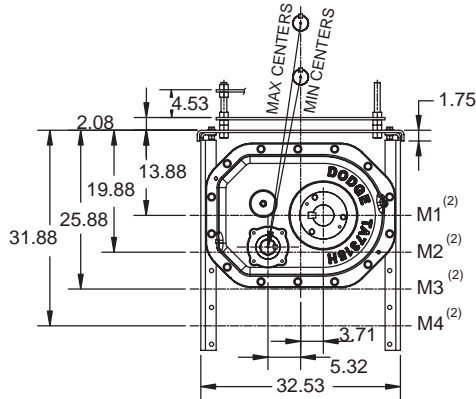

POSITION A

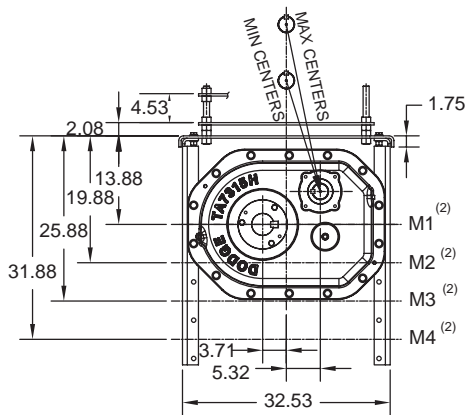
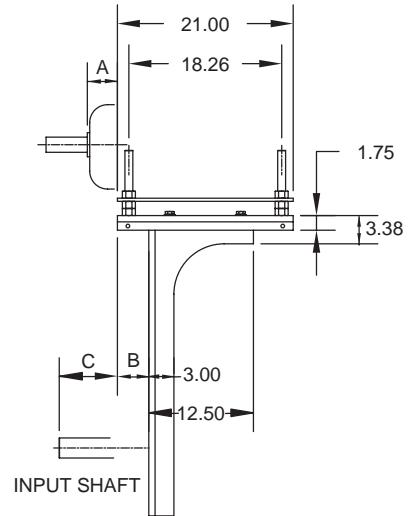

POSITION C

FEATURES/BENEFITS PAGE G1-3	NOMENCLATURE PAGE G1-8	SELECTION PAGE G1-12	RELATED PRODUCTS PAGE G1-123
--------------------------------	---------------------------	-------------------------	---------------------------------

SELECTION/DIMENSIONS



TORQUE-ARM II Shaft Mount Speed Reducers

MOTOR MOUNT DIMENSIONS - TA7315H, POSITION A & C (1) (3)

Mounting	Lateral Adjustment				Motor Mount Height (2)	Motor Frame														
						213T & 215T		254T & 256T		284T & 286T										
	B Min	B Max	C Min	C Max		A	Centers		A	Centers		A	Centers							
Position A	1.59	5.91	6.04	10.36	M1	1.55	27.4	31.4	1.56	28.4	32.4	1.16	29.1	33.1						
					M2										33.3	37.3	34.3	38.3	35.0	39.0
					M3										39.2	43.2	40.2	44.2	41.0	45.0
					M4										45.2	49.2	46.2	50.2	46.9	50.9
Position C	1.59	5.91	6.04	10.36	M1	1.55	17.4	21.3	1.56	18.4	22.2	1.16	19.1	23.0						
					M2										23.2	27.1	24.2	28.1	24.9	28.8
					M3										29.1	33.0	30.0	34.0	30.8	34.7
					M4										35.0	39.0	36.0	39.9	36.7	40.7

Mounting	Lateral Adjustment				Motor Mount Height (2)	Motor Frame														
						324T & 326T		364T & 365T		404T & 405T										
	B Min	B Max	C Min	C Max		A	Centers		A	Centers		A	Centers							
Position A	1.59	5.91	6.04	10.36	M1	0.38	30.1	34.1	1.01	31.1	35.1	0.75	32.1	36.1						
					M2										36.0	40.0	37.0	41.0	38.0	42.0
					M3										42.0	46.0	43.0	47.0	44.0	48.0
					M4										47.9	51.9	48.9	52.9	49.9	53.9
Position C	1.59	5.91	6.04	10.36	M1	0.38	20.0	23.9	1.01	21.0	24.9	0.75	22.0	25.9						
					M2										25.9	29.8	26.9	30.8	27.8	31.8
					M3										31.8	35.7	32.8	36.7	33.7	37.7
					M4										37.7	41.7	38.7	42.7	39.7	43.7

Notes:

Minimum centers contains 0.5" to allow for belt assembly

- (1) Motor mount will fit NEMA and IEC frame motors; hardware are inch dimensions
- (2) M1, M2, M3, M4 go through output shaft centerline
- (3) See Table A, below, for minimum "M" mounting position required for specific screw diameter and reducer size

Table A - Screw Conveyor Motor Mount Minimum "M" Mounting Positions (1)

Nominal Screw Dia	Trough Height Dim	Minimum Mounting Position							
		TA0107L	TA1107H	TA2115H	TA3203H	TA4207H	TA5215H	TA6307H	TA7315H
6	7.00	M2	M3	M2	M2	M2	M1	M1	M1
9	9.00	M3	M4	M3	M3	M2	M2	M2	M1
12	10.00	M4	M4	M3	M3	M2	M2	M2	M1
14	11.00	M4	M4	M4	M3	M3	M2	M2	M2
16	11.50	M4	***	M4	M4	M3	M2	M2	M2
18	12.13	***	***	M4	M4	M3	M3	M2	M2
20	13.50	***	***	M4	M4	M3	M3	M3	M2
24	16.50	***	***	***	***	M4	M3	M3	M3

(1) For U Or Flared Trough Ends Per CEMA 300-014

FEATURES/BENEFITS PAGE G1-3	NOMENCLATURE PAGE G1-8	SELECTION PAGE G1-12	RELATED PRODUCTS PAGE G1-123
--------------------------------	---------------------------	-------------------------	---------------------------------

SELECTION/DIMENSIONS



TORQUE-ARM II Shaft Mount Speed Reducers TAPER BUSHED REDUCERS - TA8407H, DOUBLE REDUCTION

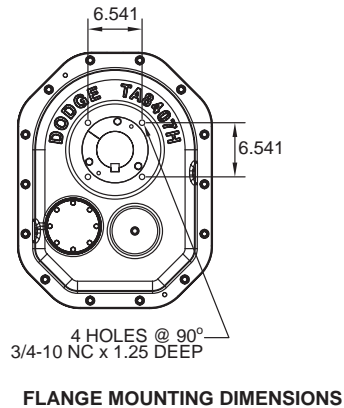
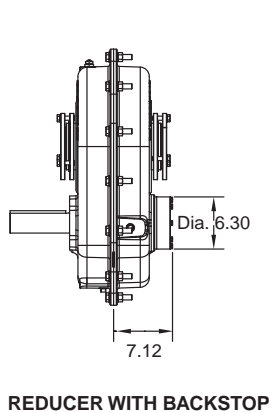
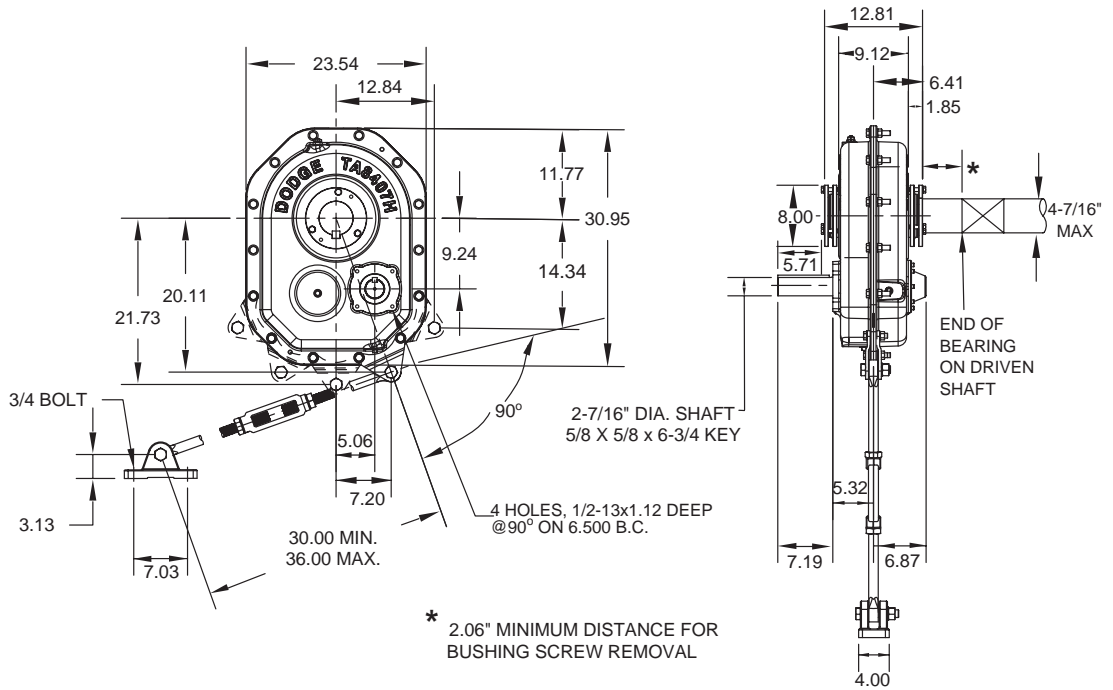

FEATURES/BENEFITS PAGE G1-3	NOMENCLATURE PAGE G1-8	SELECTION PAGE G1-12	RELATED PRODUCTS PAGE G1-123
--------------------------------	---------------------------	-------------------------	---------------------------------



TORQUE-ARM II Shaft Mount Speed Reducers TAPER BUSHED REDUCERS - TA8407H, DOUBLE REDUCTION

TA8407H Taper Bushed Reducers ⁽¹⁾

Reducer Size	Part Number	AGMA Code	Actual Ratio	Weight lbs.
TA8407H15	908002	407D15	15.12	511.0
TA8407H25	908001	407D25	24.97	511.0
TA8407H40	908000	407D40	39.67	507.0

- (1) Reducers are supplied from stock ready for vertical mounting and for flange mounting. Rod assembly is not included with reducer. Order as a separate part number.

TA8407H Accessories

Description	Part Number	Weight lbs.
TA7315/8407RA Rod Assembly (1)	907109	43.2
TA8407BS Backstop Assembly ⁽²⁾	908102	15.0
TA8407BS 40:1 Backstop Assembly ⁽²⁾	908103	15.7
TA7315/8407MM Motor Mount Assembly (213-405T) ⁽³⁾	907090	183.3
TA7315/8407BG Belt Guard - Pos. B (213-405T)	907096	147.2
TA7315/8407BG Belt Guard - Pos. C (213-405T)	907097	152.7
TA7315/8407CF Cooling Fan Assembly ●	907106	10.0
TA4-TA12 Vertical Breather Kit	904112	3.0
Filter Breather Kit	430049	0.2

- (2) See page G1-130 for input shaft speed necessary for backstop sprag lift-off
- (3) Motor Mount will fit NEMA and IEC frame motors; however hardware are inch dimensions
- See page G1-122 for cooling fan dimensions

TA8407H Tapered Bushing Kits ^{(5) (6)}

Bushing Size Standard Shaft Bushing Kit	Part Number (7)	Weight lbs.	Shaft Keyseat Required (9) (10)	Bushing Size	Part Number	Weight lbs.	Shaft Keyseat Required (9) (10)
				Short Shaft Bushing Kit ⁽⁸⁾			
TA8407TB x 4-7/16 ▲	908020	26.0	1 x 1/2 x 12.82	TA8407TBS x 4-7/16	908027	26.9	1 x 1/2 x 8.10
TA8407TB x 4-3/16	908021	29.0	1 x 1/2 x 12.82	TA8407TBS x 4-3/16	908028	31.3	1 x 1/2 x 8.10
TA8407TB x 3-15/16	908022	32.1	1 x 1/2 x 12.82	TA8407TBS x 3-15/16	908029	35.6	1 x 1/2 x 8.10
TA8407TB x 3-7/16	908023	36.7	7/8 x 7/16 x 12.82	TA8407TBS x 3-7/16	908030	42.4	7/8 x 7/16 x 8.10
TA8407TB x 3-3/16	908024	38.4	3/4 x 3/8 x 12.82	TA8407TBS x 3-3/16	908031	45.3	3/4 x 3/8 x 8.10
TA8407TB x 3	908025	39.8	3/4 x 3/8 x 12.82	TA8407TBS x 3	908032	47.5	3/4 x 3/8 x 8.10
TA8407TB x 2-15/16	908026	40.4	3/4 x 3/8 x 12.82	TA8407TBS x 2-15/16	908033	48.3	3/4 x 3/8 x 8.10

- ▲ AGMA maximum bore size
- (5) Bushing kit required to mount TA II reducer to driven shaft
- (6) Bushing Kit is not required to mount TA II reducer on SCS Drive Shaft in a screw conveyor application
- (7) Standard Shaft Bushing Kit includes two standard bushings with backup plates and snap rings; hardware and one key
- (8) Short Shaft Bushing Kit includes one standard bushing; one long bushing with mounting wedge; two backup plates with snap rings; hardware and one key. This is an optional bushing for after market, short shaft mounting.
- (9) Minimum keyseat and shaft length required to mount reducer with bushing kit
- (10) Always check the driven shaft and key for strength

FEATURES/BENEFITS PAGE G1-3	NOMENCLATURE PAGE G1-8	SELECTION PAGE G1-12	RELATED PRODUCTS PAGE G1-123
--------------------------------	---------------------------	-------------------------	---------------------------------



SELECTION/DIMENSIONS

TORQUE-ARM II Shaft Mount Speed Reducers MOTOR MOUNT DIMENSIONS - TA8407H, POSITION B & D

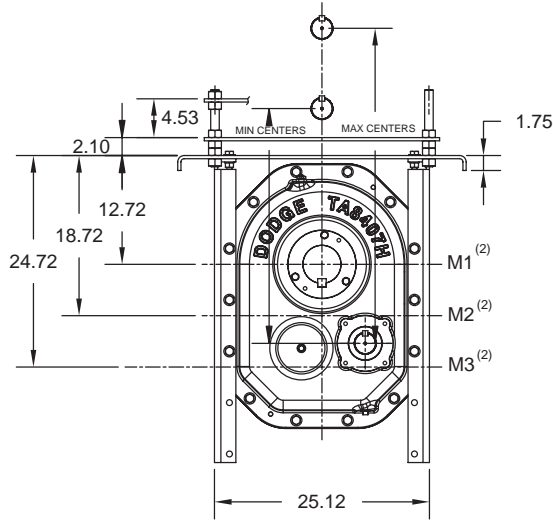

POSITION B

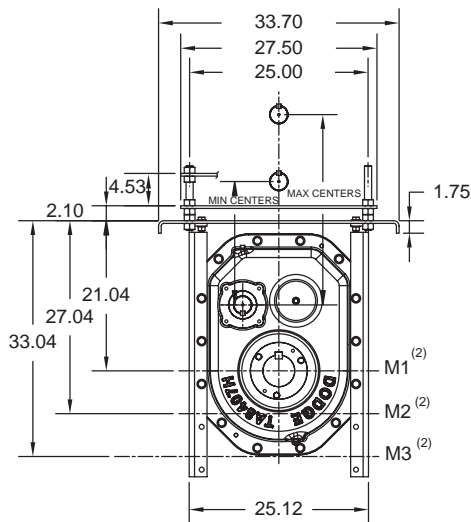
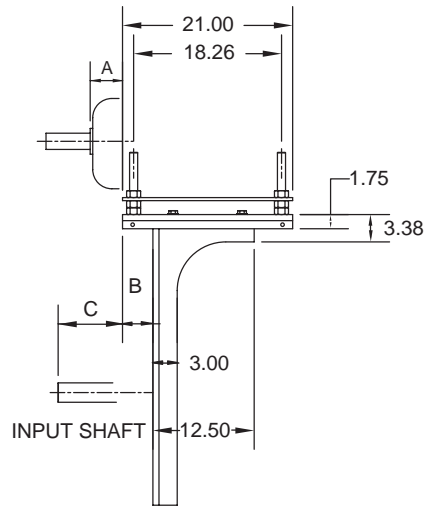

POSITION D

FEATURES/BENEFITS PAGE G1-3	NOMENCLATURE PAGE G1-8	SELECTION PAGE G1-12	RELATED PRODUCTS PAGE G1-123
--------------------------------	---------------------------	-------------------------	---------------------------------

SELECTION/DIMENSIONS



TORQUE-ARM II Shaft Mount Speed Reducers MOTOR MOUNT DIMENSIONS - TA8407H, POSTION B & D ⁽¹⁾

Mounting	Lateral Adjustment				Motor Mount Height (2)	Motor Frame								
						213T & 215T			254T & 256T			284T & 286T		
	B Min	B Max	C Min	C Max		A	Centers		A	Centers		A	Centers	
							Min	Max		Min	Max		Min	Max
Position B	1.59	5.91	5.78	10.10	M1	1.55	30.2	34.2	1.56	31.2	35.2	1.16	32.0	35.9
					M2		36.2	40.1		37.1	41.1		37.9	41.9
					M3		42.1	46.1		43.1	47.1		43.8	47.8
Position D	1.59	5.91	5.78	10.10	M1	1.55	20.3	24.2	1.56	21.3	25.2	1.16	22.0	25.9
					M2		26.1	30.1		27.1	31.1		27.9	31.8
					M3		32.1	36.0		33.0	37.0		33.8	37.8

Mounting	Lateral Adjustment				Motor Mount Height (2)	Motor Frame								
						324T & 326T			364T & 365T			404T & 405T		
	B Min	B Max	C Min	C Max		A	Centers		A	Centers		A	Centers	
							Min	Max		Min	Max		Min	Max
Position B	1.59	5.91	5.78	10.10	M1	0.38	32.9	36.9	1.01	33.9	37.9	0.75	34.9	38.9
					M2		38.9	42.9		39.9	43.9		40.9	44.9
					M3		44.8	48.8		45.8	49.8		46.8	50.8
Position D	1.59	5.91	5.78	10.10	M1	0.38	23.0	26.9	1.01	23.9	27.9	0.75	24.9	28.9
					M2		28.8	32.8		29.8	33.8		30.8	34.8
					M3		34.8	38.8		35.8	39.7		36.7	40.7

Note:

Minimum centers contains 0.5" to allow for belt assembly

(1) Motor mount will fit NEMA and IEC frame motors; hardware are inch dimensions

(2) M1, M2, M3 go through output shaft centerline

FEATURES/BENEFITS PAGE G1-3	NOMENCLATURE PAGE G1-8	SELECTION PAGE G1-12	RELATED PRODUCTS PAGE G1-123
--------------------------------	---------------------------	-------------------------	---------------------------------

SELECTION/DIMENSIONS



TORQUE-ARM II Shaft Mount Speed Reducers MOTOR MOUNT DIMENSIONS - TA8407H, POSITION A & C

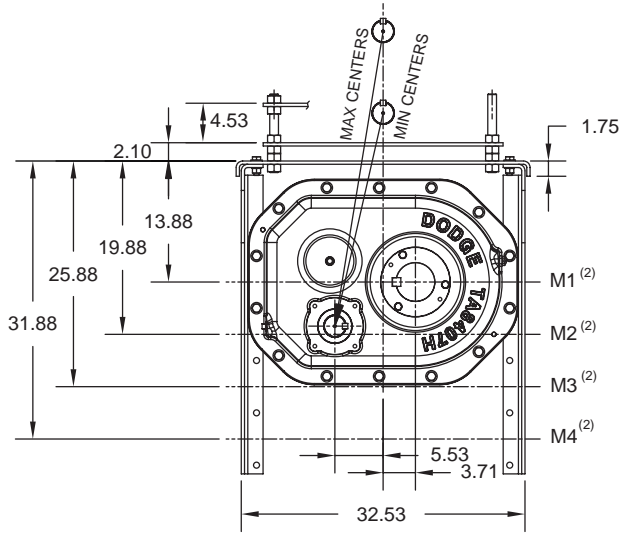

POSITION A

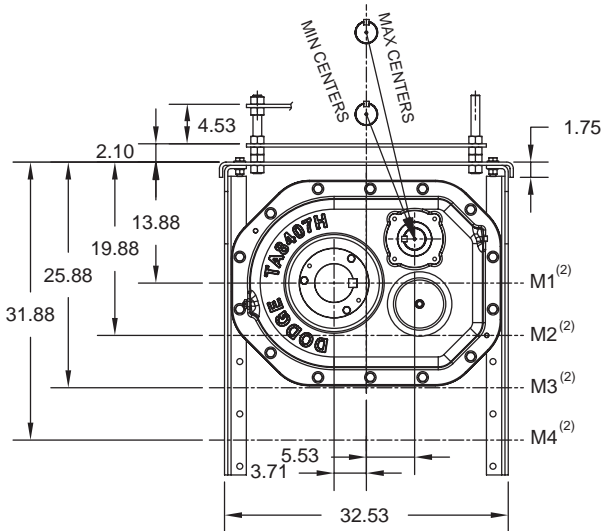

POSITION C

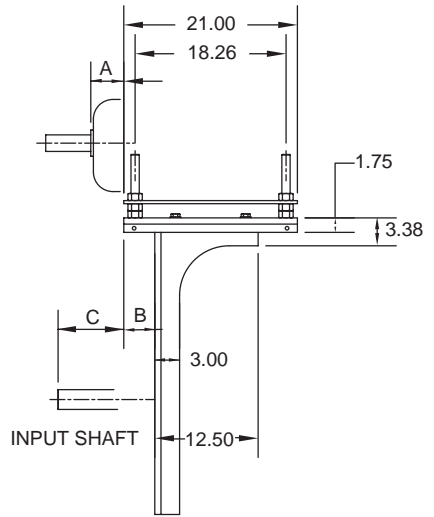

<p>FEATURES/BENEFITS PAGE G1-3</p>	<p>NOMENCLATURE PAGE G1-8</p>	<p>SELECTION PAGE G1-12</p>	<p>RELATED PRODUCTS PAGE G1-123</p>
--	-----------------------------------	---------------------------------	---

SELECTION/DIMENSIONS



TORQUE-ARM II Shaft Mount Speed Reducers

MOTOR MOUNT DIMENSIONS - TA8407H, POSITION A & C ⁽¹⁾

Mounting	Lateral Adjustment				Motor Mount Height (2)	Motor Frame								
						213T & 215T			254T & 256T			284T & 286T		
	B Min	B Max	C Min	C Max		A	Centers		A	Centers		A	Centers	
							Min	Max		Min	Max		Min	Max
Position A	1.59	5.91	7.04	11.36	M1	1.55	27.4	31.3	1.56	28.3	32.3	1.16	29.1	33.0
					M2		33.2	37.2		34.2	38.2		35.0	39.0
					M3		39.2	43.2		40.2	44.2		40.9	44.9
					M4		45.1	49.1		46.1	50.1		46.9	50.9
Position C	1.59	5.91	7.04	11.36	M1	1.55	17.6	21.4	1.56	18.5	22.4	1.16	19.2	23.1
					M2		23.3	27.3		24.3	28.2		25.0	29.0
					M3		29.2	33.2		30.2	34.1		30.9	34.9
					M4		35.1	39.1		36.1	40.1		36.8	40.8

Mounting	Lateral Adjustment				Motor Mount Height (2)	Motor Frame								
						324T & 326T			364T & 365T			404T & 405T		
	B Min	B Max	C Min	C Max		A	Centers		A	Centers		A	Centers	
							Min	Max		Min	Max		Min	Max
Position A	1.59	5.91	7.04	11.36	M1	0.38	30.1	34.0	1.01	31.0	35.0	0.75	32.0	36.0
					M2		36.0	39.9		37.0	40.9		37.9	41.9
					M3		41.9	45.9		42.9	46.9		43.9	47.9
					M4		47.9	51.9		48.8	52.8		49.8	53.8
Position C	1.59	5.91	7.04	11.36	M1	0.38	20.2	24.1	1.01	21.2	25.1	0.75	22.1	26.0
					M2		26.0	30.0		27.0	30.9		28.0	31.9
					M3		31.9	35.9		32.9	36.9		33.9	37.8
					M4		37.8	41.8		38.8	42.8		39.8	43.8

Notes:

Minimum centers contains 0.5" to allow for belt assembly

- (1) Motor mount will fit NEMA and IEC frame motors; hardware are inch dimensions
- (2) M1, M2, M3, M4 go through output shaft centerline

FEATURES/BENEFITS PAGE G1-3	NOMENCLATURE PAGE G1-8	SELECTION PAGE G1-12	RELATED PRODUCTS PAGE G1-123
--------------------------------	---------------------------	-------------------------	---------------------------------

SELECTION/DIMENSIONS



TORQUE-ARM II Shaft Mount Speed Reducers TAPER BUSHED REDUCERS - TA9415H, DOUBLE REDUCTION

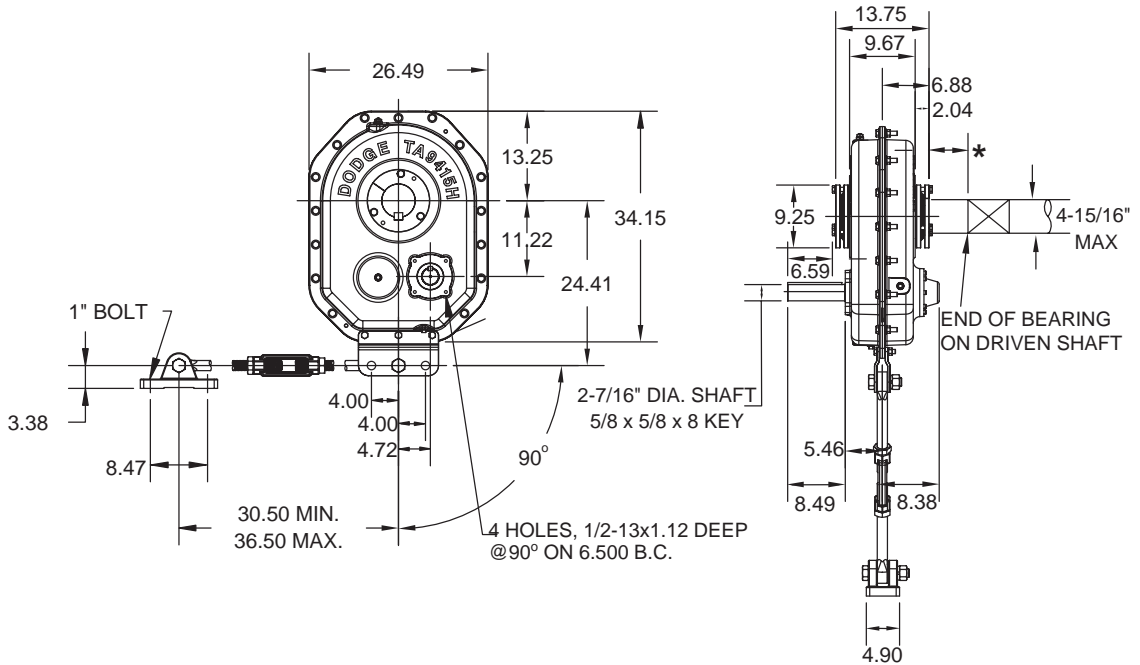

* 2.39" MINIMUM DISTANCE FOR BUSHING SCREW REMOVAL

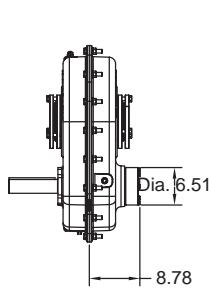

REDUCER WITH BACKSTOP

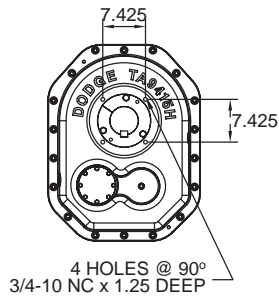

FLANGE MOUNTING DIMENSIONS

FEATURES/BENEFITS PAGE G1-3	NOMENCLATURE PAGE G1-8	SELECTION PAGE G1-12	RELATED PRODUCTS PAGE G1-123
--------------------------------	---------------------------	-------------------------	---------------------------------



TORQUE-ARM II Shaft Mount Speed Reducers TAPER BUSHED REDUCERS - TA9415H, DOUBLE REDUCTION

TA9415H Taper Bushed Reducers ⁽¹⁾

Reducer Size	Part Number	AGMA Code	Actual Ratio	Weight lbs.
TA9415H15	909002	415D15	15.10	735.0
TA9415H25	909001	415D25	25.44	735.0
TA9415H40	909000	415D40	39.41	732.0

- (1) Reducers are supplied from stock ready for vertical mounting and for flange mounting. Rod assembly is not included with reducer. Order as a separate part number.

TA9415H Accessories

Description	Part Number	Weight lbs.
TA9415RA Rod Assembly ⁽¹⁾	909109	76.8
TA9415BS Backstop Assembly ⁽²⁾	909102	20.0
TA7315/9415BS 40:1 Backstop Assembly ⁽²⁾	907103	21.0
TA9415MM Motor Mount Assembly (254-445T) ⁽³⁾	909090	273.7
TA9415BG Belt Guard - Pos. B (254-445T)	909096	158.1
TA9415CF Cooling Fan Assembly	909106	12.4
TA4-TA12 Vertical Breather Kit	904112	3.0
Filter Breather Kit	430049	0.2

- (2) See page G1-130 for input shaft speed necessary for backstop sprag lift-off
- (3) Motor Mount will fit NEMA and IEC frame motors; however hardware are inch dimensions
- See page G1-122 for cooling fan dimensions

TA9415H Tapered Bushing Kits ^{(5) (6)}

Bushing Size Standard Shaft Bushing Kit	Part Number ⁽⁷⁾	Weight lbs.	Shaft Keyseat Required ^{(9) (10)}	Bushing Size	Part Number	Weight lbs.	Shaft Keyseat Required ^{(9) (10)}
				Short Shaft Bushing Kit ⁽⁸⁾			
TA9415TB x 4-15/16 ▲	909020	38.4	1-1/4 x 5/8 x 13.74	TA9415TBS x 4-15/16	909025	40.2	1-1/4 x 5/8 x 8.56
TA9415TB x 4-7/16	909021	43.4	1 x 1/2 x 13.74	TA9415TBS x 4-7/16	909026	48.8	1 x 1/2 x 8.56
TA9415TB x 4-3/16	909022	46.4	1 x 1/2 x 13.74	TA9415TBS x 4-3/16	909027	53.4	1 x 1/2 x 8.56
TA9415TB x 3-15/16	909023	49.2	1 x 1/2 x 13.74	TA9415TBS x 3-15/16	909028	57.7	1 x 1/2 x 8.56
TA9415TB x 3-7/16	909024	53.1	7/8 x 7/16 x 13.74	TA9415TBS x 3-7/16	909029	64.4	7/8 x 7/16 x 8.56

▲ AGMA maximum bore size

- (5) Bushing kit required to mount TA II reducer to driven shaft
- (6) (Bushing Kit is not required to mount TA II reducer on SCS Drive Shaft in a screw conveyor application)
- (7) Standard Shaft Bushing Kit includes two standard bushings with backup plates and snap rings; hardware and one key
- (8) Short Shaft Bushing Kit includes one standard bushing; one long bushing with mounting wedge; two backup plates with snap rings; hardware and one key. This is an optional bushing for after market, short shaft mounting.
- (9) Minimum keyseat and shaft length required to mount reducer with bushing kit
- (10) Always check the driven shaft and key for strength

FEATURES/BENEFITS PAGE G1-3	NOMENCLATURE PAGE G1-8	SELECTION PAGE G1-12	RELATED PRODUCTS PAGE G1-123
--------------------------------	---------------------------	-------------------------	---------------------------------

SELECTION/DIMENSIONS



TORQUE-ARM II Shaft Mount Speed Reducers MOTOR MOUNT DIMENSIONS - TA9415H, POSITION B & D ⁽¹⁾

Mounting	Lateral Adjustment				Motor Frame									
					Motor Mount Height (2)	254T & 256T		284T & 286T		324T & 326T				
	B Min	B Max	C Min	C Max		A	Centers		A	Centers		A	Centers	
							Min	Max		Min	Max		Min	Max
Position B	2.18	6.82	6.26	10.90	M1	1.56	35.5	39.2	1.16	36.2	40.0	0.38	37.2	41.0
					M2		40.5	44.2		41.2	45.0		42.2	46.0
Position D	2.18	6.82	6.26	10.90	M1	1.56	21.3	25.0	1.16	22.0	25.7	0.38	23.0	26.7
					M2		26.2	29.9		26.9	30.6		27.9	31.6

Mounting	Lateral Adjustment				Motor Frame									
					Motor Mount Height (2)	364T & 365T		404T & 405T		444T & 445T				
	B Min	B Max	C Min	C Max		A	Centers		A	Centers		A	Centers	
							Min	Max		Min	Max		Min	Max
Position B	2.18	6.82	6.26	10.90	M1	1.01	38.2	42.0	0.75	39.2	43.0	1.62	40.2	44.0
					M2		43.2	47.0		44.2	47.9		45.2	48.9
Position D	2.18	6.82	6.26	10.90	M1	1.01	24.0	27.7	0.75	25.0	28.7	1.62	25.9	29.7
					M2		28.9	32.6		29.9	33.6		30.9	34.6

Note:

Minimum centers contains 0.5" to allow for belt assembly

(1) Motor mount will fit NEMA and IEC frame motors; hardware are inch dimensions

(2) M1, M2, M3 go through output shaft centerline

FEATURES/BENEFITS PAGE G1-3	NOMENCLATURE PAGE G1-8	SELECTION PAGE G1-12	RELATED PRODUCTS PAGE G1-123
--------------------------------	---------------------------	-------------------------	---------------------------------

SELECTION/DIMENSIONS



TORQUE-ARM II Shaft Mount Speed Reducers TAPER BUSHED REDUCERS - TA10507H, DOUBLE REDUCTION

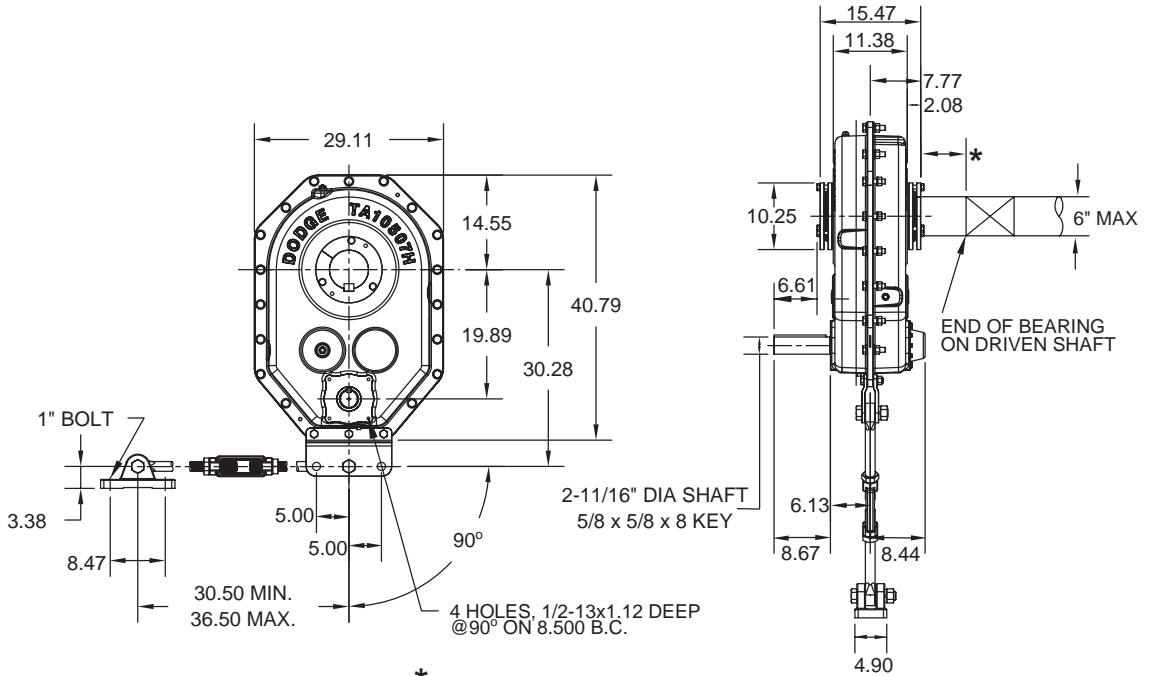

* 2.39 MINIMUM DISTANCE FOR BUSHING SCREW REMOVAL

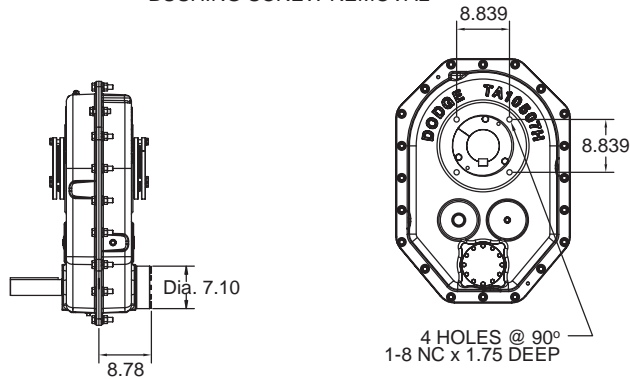

REDUCER WITH BACKSTOP

FLANGE MOUNTING DIMENSIONS

FEATURES/BENEFITS PAGE G1-3	NOMENCLATURE PAGE G1-8	SELECTION PAGE G1-12	RELATED PRODUCTS PAGE G1-123
--------------------------------	---------------------------	-------------------------	---------------------------------



TORQUE-ARM II Shaft Mount Speed Reducers TAPER BUSHED REDUCERS - TA10507H, DOUBLE REDUCTION

TA10507H Taper Bushed Reducers (1)

Reducer Size	Part Number	AGMA Code	Actual Ratio	Weight lbs.
TA10507H15	910002	507D15	15.09	1022.0
TA10507H25	910001	507D25	25.18	1022.0
TA10507H40	910000	507D40	39.68	1018.0

(1) Reducers are supplied from stock ready for vertical mounting and for flange mounting. Rod assembly is not included with reducer. Order as a separate part number.

TA10507H Accessories

Description	Part Number	Weight lbs.
TA10507RA Rod Assembly (1)	910109	87.0
TA10507BS Backstop Assembly (2)	910102	23.5
TA10507BS 40:1 Backstop Assembly (2)	910103	25.0
TA10507MM Motor Mount Assembly (254-445T) (3)	910090	286.7
TA10507BG Belt Guard - Pos. B (254-445T)	910096	158.1
TA10507CF Cooling Fan Assembly ●	910106	12.4
TA4-TA12 Vertical Breather Kit	904112	3.0
Filter Breather Kit	430049	0.2

(2) See page G1-130 for input shaft speed necessary for backstop sprag lift-off

(3) Motor Mount will fit NEMA and IEC frame motors; however hardware are inch dimensions

● See page G1-122 for cooling fan dimensions

TA10507H Tapered Bushing Kits (5) (6)

Bushing Size Standard Shaft Bushing Kit	Part Number (7)	Weight lbs.	Shaft Keyseat Required (9) (10)	Bushing Size	Part Number	Weight lbs.	Shaft Keyseat Required (9) (10)
				Short Shaft Bushing Kit (8)			
TA10507TB x 6	910020	40.8	1-1/2 x 3/4 x 15.46	---	---	---	---
TA10507TB x 5-15/16	910021	43.2	1-1/2 x 3/4 x 15.46	---	---	---	---
TA10507TB x 5-7/16 ▲	910022	50.0	1-1/4 x 5/8 x 15.46	TA10507TBS x 5-7/16	910027	47.2	1-1/4 x 5/8 x 9.67
TA10507TB x 4-15/16	910023	57.8	1-1/4 x 5/8 x 15.46	TA10507TBS x 4-15/16	910028	66.9	1-1/4 x 5/8 x 9.67
TA10507TB x 4-7/16	910024	52.8	1 x 1/2 x 15.46	TA10507TBS x 4-7/16	910029	75.7	1 x 1/2 x 9.67
TA10507TB x 4-3/16	910025	65.6	1 x 1/2 x 15.46	TA10507TBS x 4-3/16	910030	80.5	1 x 1/2 x 9.67
TA10507TB x 3-15/16	910026	68.4	1 x 1/2 x 15.46	TA10507TBS x 3-15/16	910031	85.2	1 x 1/2 x 9.67

▲ AGMA maximum bore size

(5) Bushing kit required to mount TA II reducer to driven shaft

(6) Bushing Kit is not required to mount TA II reducer on SCS Drive Shaft in a screw conveyor application

(7) Standard Shaft Bushing Kit includes two standard bushings with backup plates and snap rings; hardware and one key

(8) Short Shaft Bushing Kit includes one standard bushing; one long bushing with mounting wedge; two backup plates with snap rings; hardware and one key. This is an optional bushing for after market, short shaft mounting.

(9) Minimum keyseat and shaft length required to mount reducer with bushing kit

(10) Always check the driven shaft and key for strength

FEATURES/BENEFITS PAGE G1-3	NOMENCLATURE PAGE G1-8	SELECTION PAGE G1-12	RELATED PRODUCTS PAGE G1-123
--------------------------------	---------------------------	-------------------------	---------------------------------



SELECTION/DIMENSIONS

TORQUE-ARM II Shaft Mount Speed Reducers MOTOR MOUNT DIMENSIONS - TA10507H, POSTION B & D

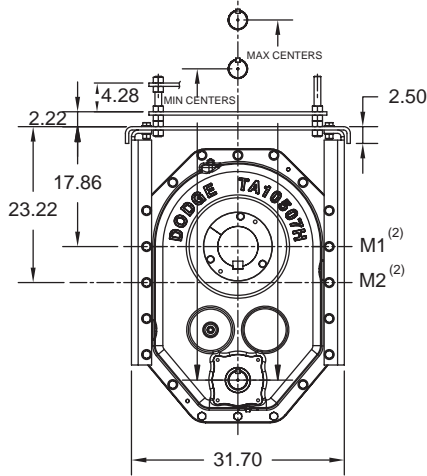

POSITION B

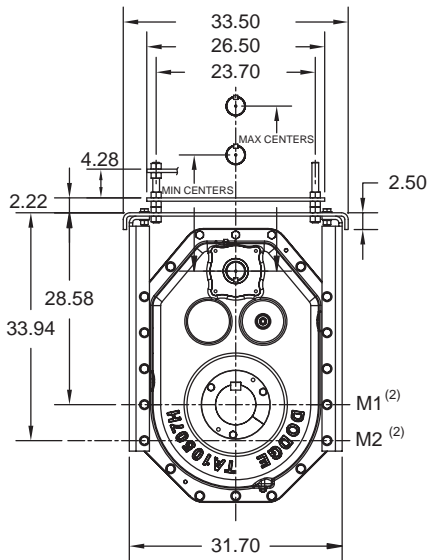

POSITION D

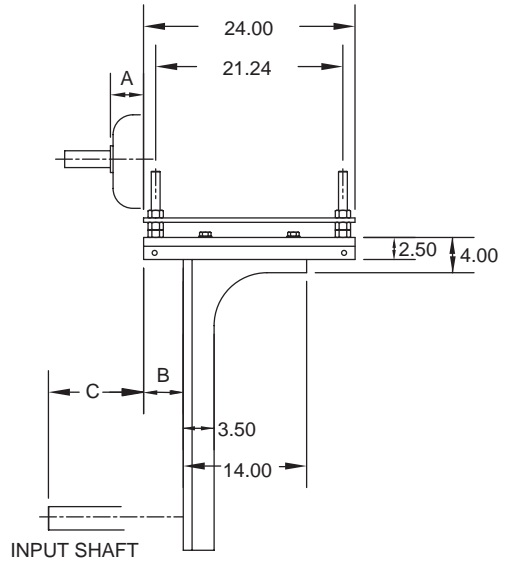

INPUT SHAFT

SELECTION/DIMENSIONS



TORQUE-ARM II Shaft Mount Speed Reducers

MOTOR MOUNT DIMENSIONS - TA10507H, POSTION B & D ⁽¹⁾

Mounting	Lateral Adjustment				Motor Mount Height (2)	Motor Frame								
						254T & 256T			284T & 286T			324T & 326T		
	B Min	B Max	C Min	C Max		A	Centers		A	Centers		A	Centers	
							Min	Max		Min	Max		Min	Max
Position B	2.18	6.82	6.98	11.62	M1	1.56	46.7	50.5	1.16	47.5	51.2	0.38	48.5	52.2
					M2		52.1	55.9		52.8	56.6		53.8	57.6
Position D	2.18	6.82	6.98	11.62	M1	1.56	17.7	21.4	1.16	18.4	22.2	0.38	19.4	23.2
					M2		23.0	26.8		23.8	27.5		24.8	28.5

Mounting	Lateral Adjustment				Motor Mount Height (2)	Motor Frame								
						364T & 365T			404T & 405T			444T & 445T		
	B Min	B Max	C Min	C Max		A	Centers		A	Centers		A	Centers	
							Min	Max		Min	Max		Min	Max
Position B	2.18	6.82	6.98	11.62	M1	1.01	49.5	53.2	0.75	50.5	54.2	1.62	51.5	55.2
					M2		54.8	58.6		55.8	59.6		56.8	60.6
Position D	2.18	6.82	6.98	11.62	M1	1.01	20.4	24.2	0.75	21.4	25.2	1.62	22.4	26.2
					M2		25.8	29.5		26.8	30.5		27.8	31.5

Note:

Minimum centers contains 0.5" to allow for belt assembly

(1) Motor mount will fit NEMA and IEC frame motors; hardware are inch dimensions

(2) M1, M2, M3 go through output shaft centerline

FEATURES/BENEFITS PAGE G1-3	NOMENCLATURE PAGE G1-8	SELECTION PAGE G1-12	RELATED PRODUCTS PAGE G1-123
--------------------------------	---------------------------	-------------------------	---------------------------------



SELECTION/DIMENSIONS

TORQUE-ARM II Shaft Mount Speed Reducers TAPER BUSHED REDUCERS - TA12608H, DOUBLE REDUCTION

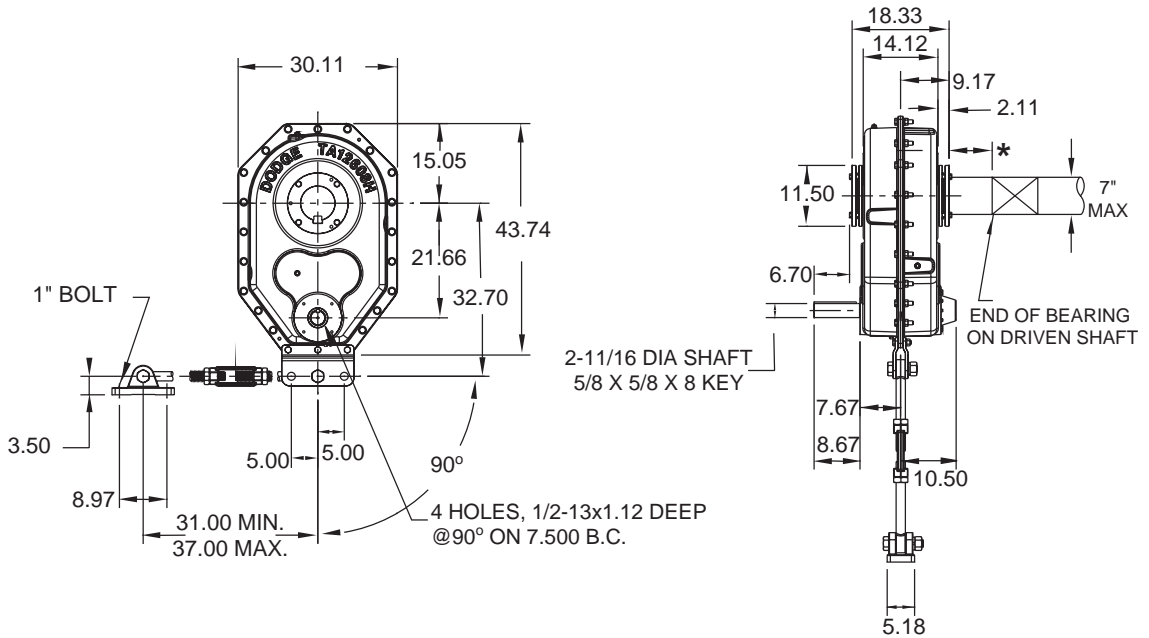

* 2.39" MINIMUM DISTANCE FOR BUSHING SCREW REMOVAL

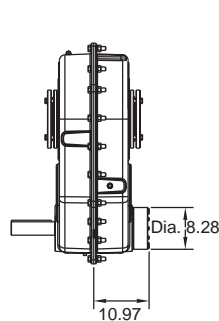

REDUCER WITH BACKSTOP

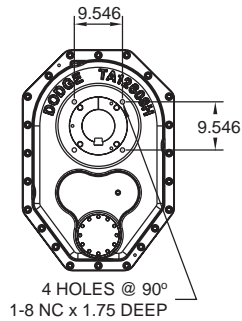

FLANGE MOUNTING DIMENSIONS

FEATURES/BENEFITS PAGE G1-3	NOMENCLATURE PAGE G1-8	SELECTION PAGE G1-12	RELATED PRODUCTS PAGE G1-123
--------------------------------	---------------------------	-------------------------	---------------------------------



TORQUE-ARM II Shaft Mount Speed Reducers TAPER BUSHED REDUCERS - TA12608H, DOUBLE REDUCTION

TA12608H Taper Bushed Reducers ⁽¹⁾

Reducer Size	Part Number	AGMA Code	Actual Ratio	Weight lbs.
TA12608H15	912002	608D15	14.79	1392.0
TA12608H25	912001	608D25	25.03	1395.0
TA12608H40	912000	608D40	38.19	1393.0

- (1) Reducers are supplied from stock ready for vertical mounting and for flange mounting. Rod assembly is not included with reducer. Order as a separate part number.

TA12608H Accessories

Description	Part Number	Weight lbs.
TA12608RA Rod Assembly ⁽¹⁾	912109	106.4
TA12608BS Backstop Assembly ⁽²⁾	912102	40.0
TA12608BS 40:1 Backstop Assembly ⁽²⁾	912103	41.1
TA12608MM Motor Mount Assembly (254-445T) ⁽³⁾	912090	289.6
TA12608BG Belt Guard - Pos. B (254-445T)	912096	190.5
TA12608CF Cooling Fan Assembly ●	912106	13.7
TA4-TA12 Vertical Breather Kit	904112	3.0
Filter Breather Kit	430049	0.2

- (2) See page G1-130 for input shaft speed necessary for backstop sprag lift-off
- (3) Motor Mount will fit NEMA and IEC frame motors; however hardware are inch dimensions
- See page G1-122 for cooling fan dimensions

TA12608H Tapered Bushing Kits ^{(5) (6)}

Bushing Size Standard Shaft Bushing Kit	Part Number (7)	Weight lbs.	Shaft Keyseat Required (9) (10)	Bushing Size	Part Number	Weight lbs.	Shaft Keyseat Required (9) (10)
				Short Shaft Bushing Kit ⁽⁸⁾			
TA12608TB x 7	912020	58.2	1-3/4 x 3/4 x 18.32	---	---	---	---
TA12608TB x 6-1/2 ▲	912021	67.8	1-1/2 x 3/4 x 18.32	TA12608TBS x 6-1/2	912027	73.5	1-1/2 x 3/4 x 11.60
TA12608TB x 6-7/16	912022	69.1	1-1/2 x 3/4 x 18.32	TA12608TBS x 6-7/16	912028	75.7	1-1/2 x 3/4 x 11.60
TA12608TB x 6	912023	78.1	1-1/2 x 3/4 x 18.32	TA12608TBS x 6	912029	90.5	1-1/2 x 3/4 x 11.60
TA12608TB x 5-15/16	912024	79.4	1-1/2 x 3/4 x 18.32	TA12608TBS x 5-15/16	912030	92.6	1-1/2 x 3/4 x 11.60
TA12608TB x 5-7/16	912025	86.7	1-1/4 x 5/8 x 18.32	TA12608TBS x 5-7/16	912031	106.1	1-1/4 x 5/8 x 11.60
TA12608TB x 4-15/16	912026	94.6	1-1/4 x 5/8 x 18.32	TA12608TBS x 4-15/16	912032	119.3	1-1/4 x 5/8 x 11.60

▲ AGMA maximum bore size

- (5) Bushing Kit required to mount TA II reducer to driven shaft
- (6) Bushing Kit is not required to mount TA II reducer on SCS Drive Shaft in a screw conveyor application
- (7) Standard Shaft Bushing Kit includes two standard bushings with backup plates and snap rings; hardware and one key
- (8) Short Shaft Bushing Kit includes one standard bushing; one long bushing with mounting wedge; two backup plates with snap rings; hardware and one key. This is an optional bushing for after market, short shaft mounting.
- (9) Minimum keyseat and shaft length required to mount reducer with bushing kit
- (10) Always check the driven shaft and key for strength

FEATURES/BENEFITS PAGE G1-3	NOMENCLATURE PAGE G1-8	SELECTION PAGE G1-12	RELATED PRODUCTS PAGE G1-123
--------------------------------	---------------------------	-------------------------	---------------------------------



SELECTION/DIMENSIONS

TORQUE-ARM II Shaft Mount Speed Reducers MOTOR MOUNT DIMENSIONS - TA12608H, POSITION B & D

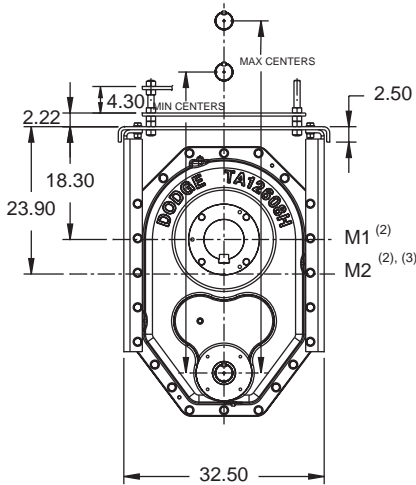

POSITION B

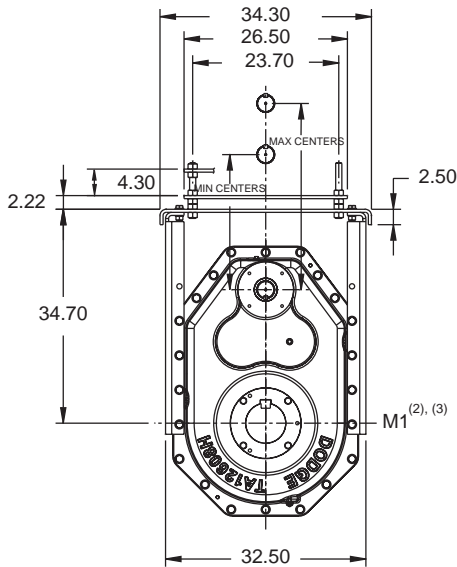

POSITION D

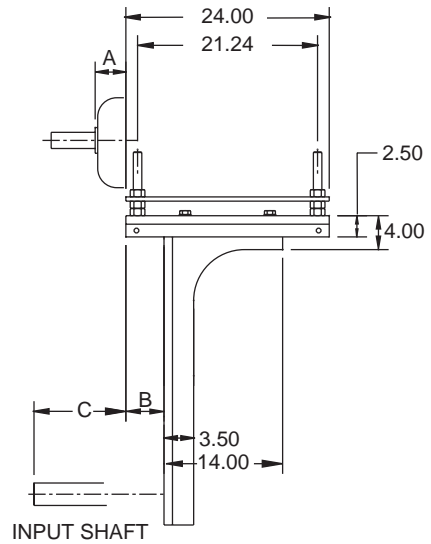

FEATURES/BENEFITS PAGE G1-3	NOMENCLATURE PAGE G1-8	SELECTION PAGE G1-12	RELATED PRODUCTS PAGE G1-123
--------------------------------	---------------------------	-------------------------	---------------------------------

SELECTION/DIMENSIONS



TORQUE-ARM II Shaft Mount Speed Reducers

MOTOR MOUNT DIMENSIONS - TA12608H, POSITION B & D ⁽¹⁾

Mounting	Lateral Adjustment				Motor Mount Height (2) (3)	Motor Frame								
						254T & 256T			284T & 286T			324T & 326T		
	B Min	B Max	C Min	C Max		A	Centers		A	Centers		A	Centers	
							Min	Max		Min	Max		Min	Max
Position B	1.68	7.32	8.02	13.66	M1	1.56	48.9	52.7	1.16	49.7	53.5	0.38	50.7	54.5
					M2		54.5	58.3		55.3	59.1		56.3	60.1
Position D	1.68	7.32	8.02	13.66	M1	1.56	22.0	25.8	1.16	22.8	26.6	0.38	23.8	27.6

Mounting	Lateral Adjustment				Motor Mount Height (2) (3)	Motor Frame								
						364T & 365T			404T & 405T			444T & 445T		
	B Min	B Max	C Min	C Max		A	Centers		A	Centers		A	Centers	
							Min	Max		Min	Max		Min	Max
Position B	1.68	7.32	8.02	13.66	M1	1.01	51.7	55.5	0.75	52.7	56.5	1.62	53.7	57.5
					M2		57.3	61.1		58.3	62.1		59.3	63.1
Position D	1.68	7.32	8.02	13.66	M1	1.01	24.8	28.6	0.75	25.8	29.6	1.62	26.8	30.6

Note:

Minimum centers contains 0.5" to allow for belt assembly

(1) Motor mount will fit NEMA and IEC frame motors; hardware are inch dimensions

(2) M1, M2, M3 go through output shaft centerline

FEATURES/BENEFITS PAGE G1-3	NOMENCLATURE PAGE G1-8	SELECTION PAGE G1-12	RELATED PRODUCTS PAGE G1-123
--------------------------------	---------------------------	-------------------------	---------------------------------

SELECTION/DIMENSIONS



TORQUE-ARM II Shaft Mount Speed Reducers BELT GUARD DIMENSIONS TA0107L - TA5215H

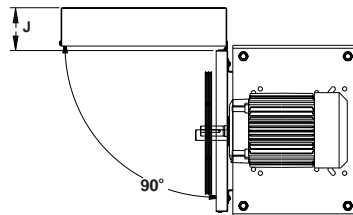
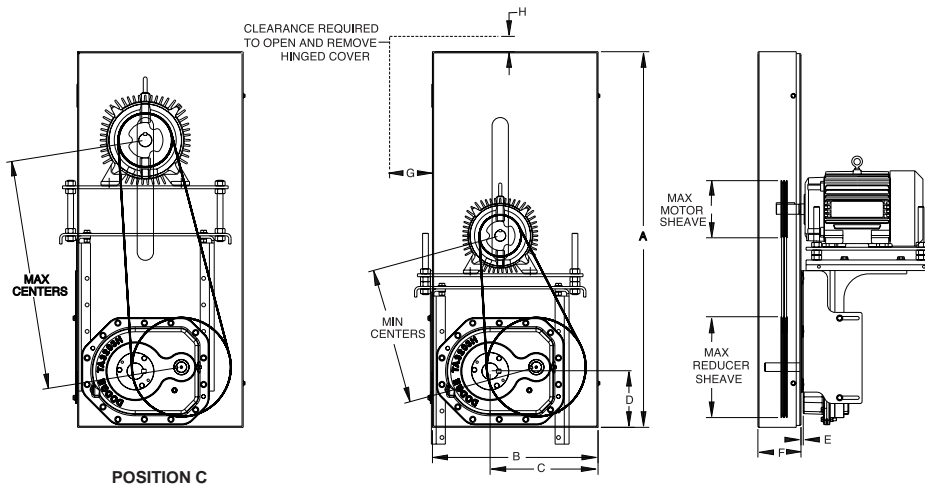
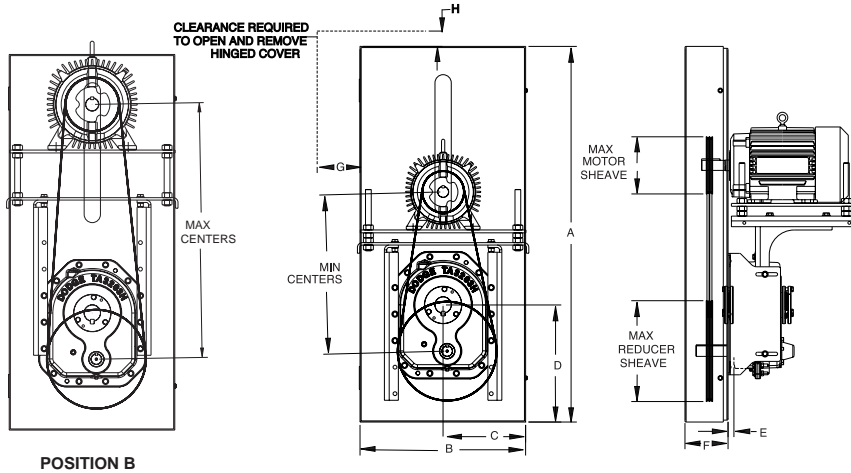

FEATURES/BENEFITS PAGE G1-3	NOMENCLATURE PAGE G1-8	SELECTION PAGE G1-12	RELATED PRODUCTS PAGE G1-123
--------------------------------	---------------------------	-------------------------	---------------------------------

SELECTION/DIMENSIONS



TORQUE-ARM II Shaft Mount Speed Reducers BELT GUARD DIMENSIONS, TA0107L - TA5215H

Case Size	Mounting Position	Centers		Max Sheave Dia.		A	B	C
		Min	Max	Motor	Reducer			
TA0107L	B	16.7	26.9	11.0	12.4	41.50	16.00	8.00
	C	14.4	25.5	11.4	12.3	41.50	16.00	10.43
TA1107H	B	16.0	28.0	10.8	12.8	41.50	16.00	8.00
	C	16.0	26.3	9.4	9.4	41.50	16.00	11.55
TA2115H	B	17.8	31.1	8.6	12.8	43.50	19.25	9.62
	C	16.8	28.9	9.3	12.3	43.50	19.25	13.07
TA3203H	B	18.9	34.3	9.2	16.8	49.00	21.60	10.80
	C	15.0	31.0	15.8	14.0	49.00	21.60	14.12
TA4207H	B	21.8	38.3	10.3	16.9	53.50	24.60	12.30
	C	22.4	35.5	16.5	15.9	53.50	24.60	16.11
TA5215H	B	25.7	44.1	11.8	17.8	60.50	27.60	13.80
	C	25.6	39.6	18.6	16.9	60.50	27.60	17.85

Case Size	Mounting Position	D	E		F	G	H	J
			Min	Max				
TA0107L	B	11.74	0.04	1.66	4.23	4.22	2.00	4.22
	C	7.33	0.04	1.66	4.23	4.22	2.00	4.22
TA1107H	B	11.74	0.00	1.57	4.23	4.22	2.00	4.22
	C	5.50	0.00	1.62	4.23	4.22	2.00	4.22
TA2115H	B	12.70	0.19	1.60	4.23	4.22	2.00	4.22
	C	7.00	0.19	1.56	4.23	4.22	2.00	4.22
TA3203H	B	15.27	0.04	2.54	5.62	5.59	2.00	5.59
	C	7.32	0.09	2.66	5.62	5.59	2.00	5.59
TA4207H	B	16.56	0.00	2.50	5.62	5.59	2.00	5.59
	C	8.32	0.13	2.70	5.62	5.59	2.00	5.59
TA5215H	B	18.25	0.00	2.44	6.37	6.09	2.00	6.09
	C	9.60	0.08	2.64	6.37	6.09	2.00	6.09

Notes:

1. Minimum centers allow 0.5" for belt assembly
2. Maximum sheave diameters allow 0.5" clearance for belt assembly
3. Range of center distances on belt guard may be less than the full range of center distances available on the motor mount
4. Belt guard cover is hinged on the left side
5. 2.00" head room required to lift belt guard cover off its hinge pins
6. Belt guard cover must be opened at least 90 degrees for removal
7. Belt guard attaches to motor mount brackets
8. "E" maximum dimension allows clearance for cooling fan
9. Stock Position-B Belt Guards cannot be used with TA II Reducers mounted in D position. A special belt guard is required.
10. Stock Position-C Belt Guards cannot be used with TA II Reducers mounted in A position. A special belt guard is required.

FEATURES/BENEFITS PAGE G1-3	NOMENCLATURE PAGE G1-8	SELECTION PAGE G1-12	RELATED PRODUCTS PAGE G1-123
--------------------------------	---------------------------	-------------------------	---------------------------------

SELECTION/DIMENSIONS



TORQUE-ARM II Shaft Mount Speed Reducers BELT GUARD DIMENSIONS TA6307H - TA12608H

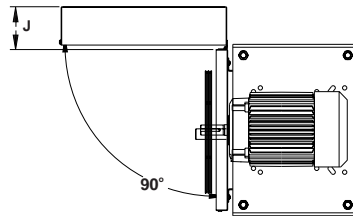
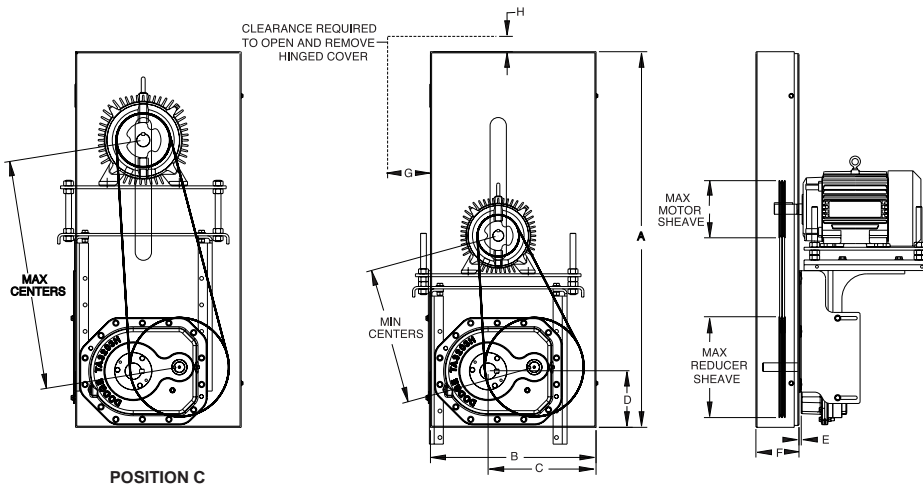
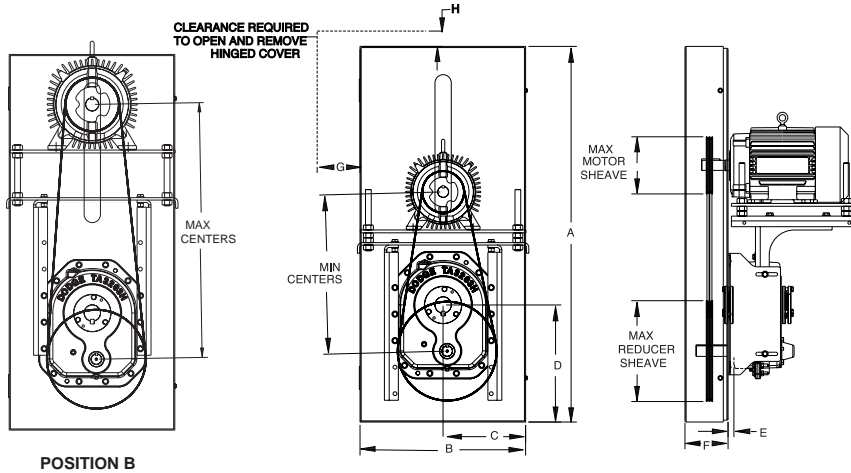

FEATURES/BENEFITS PAGE G1-3	NOMENCLATURE PAGE G1-8	SELECTION PAGE G1-12	RELATED PRODUCTS PAGE G1-123
--------------------------------	---------------------------	-------------------------	---------------------------------

SELECTION/DIMENSIONS



TORQUE-ARM II Shaft Mount Speed Reducers BELT GUARD DIMENSIONS, TA6307H - TA12608H

Case Size	Mounting Position	Centers		Max Sheave Dias.		A	B	C
		Min	Max	Motor	Reducer			
TA6307H	B	26.6	46.5	12.8	19.9	64.50	29.10	14.15
	C	26.8	40.9	21.0	20.0	64.50	29.10	17.94
TA7315H	B	29.5	50.6	12.0	25.0	71.50	30.60	18.51
	C	28.6	43.6	22.0	25.0	71.50	30.60	22.39
TA8407H	B	29.7	50.8	12.0	25.2	71.50	30.60	13.45
	C	28.7	43.8	22.0	24.6	71.50	30.60	22.39
TA9415H	B	35.0	49.2	15.4	28.0	72.50	31.60	19.57
TA10507H	B	46.2	60.8	23.2	30.8	89.50	32.60	16.30
TA12608H	B	48.4	63.3	18.2	30.8	89.50	32.60	16.30

Case Size	Mounting Position	D	E		F	G	H	J
			Min	Max				
TA6307H	B	19.92	0.00	3.56	6.87	6.59	2.00	6.59
	C	10.72	0.00	3.60	6.87	6.59	2.00	6.59
TA7315H	B	23.38	0.00	4.43	7.37	7.09	2.00	7.09
	C	10.25	0.00	3.17	7.37	7.09	2.00	7.09
TA8407H	B	14.14	0.00	4.12	7.37	7.09	2.00	7.09
	C	10.25	0.00	2.86	7.37	7.09	2.00	7.09
TA9415H	B	26.22	0.00	3.50	8.37	8.09	2.00	8.09
TA10507H	B	36.14	0.00	3.56	8.87	8.59	2.00	8.59
TA12608H	B	37.91	0.00	3.56	8.87	8.59	2.00	8.59

Notes:

1. Minimum centers allow 0.5" for belt assembly
2. Maximum sheave diameters allow 0.5" clearance for belt assembly
3. Range of center distances on belt guard may be less than the full range of center distances available on the motor mount
4. Belt guard cover is hinged on the left side
5. 2.00" head room required to lift belt guard cover off its hinge pins
6. Belt guard cover must be opened at least 90 degrees for removal
7. Belt guard attaches to motor mount brackets
8. "E" maximum dimension allows clearance for cooling fan
9. Stock Position-B Belt Guards cannot be used with TA II Reducers mounted in D position. A special belt guard is required.
10. Stock Position-C Belt Guards cannot be used with TA II Reducers mounted in A position. A special belt guard is required.

FEATURES/BENEFITS PAGE G1-3	NOMENCLATURE PAGE G1-8	SELECTION PAGE G1-12	RELATED PRODUCTS PAGE G1-123
--------------------------------	---------------------------	-------------------------	---------------------------------

SELECTION/DIMENSIONS



TORQUE-ARM II Shaft Mount Speed Reducers Cooling Fan Dimensions, TA4207H - TA12608H

When the thermal capacity of a TORQUE-ARM II reducer is exceeded, cooling fans provide an optional, inexpensive way of lowering the oil temperature, thus increasing the thermal horsepower capacity of the reducer. Selection tables indicate when a cooling fan is required.

The computer designed fan assembly, which fastens to the input shaft, is compact enough to allow installation of the V-drive originally designed for the reducer. The fan assemblies are designed to allow free circulation of air at the

back of the housing as well as through the front of the unit. The fan blade offers a radial streamline airflow, which means smaller fans yet a more efficient movement of air. See Figure 1 and Table 1 for cooling fan installation dimensions.

For thermal capacities beyond the range of cooling fans, pump and cooler auxiliary cooling packages may be used. Note: See page G1-130 for maximum input shaft speeds.

Figure 1 - Cooling Fan Assembly

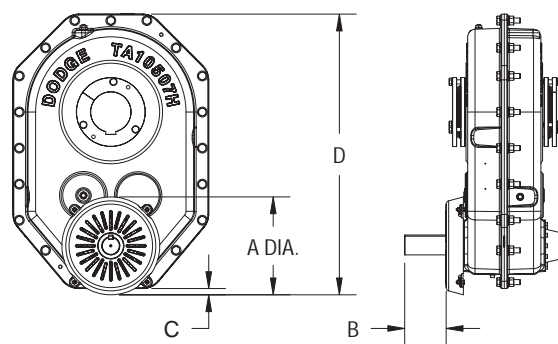

Table 1 - Cooling Fan Installation Dimensions ●

Reducer	A Dia.	B	C	D
TA4207H	9.00	3.77	---	---
TA5215H	10.75	4.63	---	---
TA6307H	11.85	4.00	0.14	25.37
TA7315H	11.85	4.10	---	---
TA8407H	11.85	4.79	---	---
TA9415H	14.55	5.98	---	---
TA10507H	14.55	6.16	0.93	41.72
TA12608H	14.55	6.16	0.25	43.98

● See individual reducer pages for cooling fan part numbers

Reducer Pump and Auxiliary Cooling Package

For thermal capacities beyond the range of cooling fans, an optional pump and cooler auxiliary cooling package is available to prevent overheating the reducer and allow the use of full mechanical HP rating by lowering the oil temperature to an acceptable level.

Specifications for the heat exchanger are as follows: 1/2 HP, 60 Hz, 3 PH. 230/460 Volt, TEFC, 56 Frame. Maximum coolant (water) flow is 3 G.P.M. based upon a maximum water temperature of 80 degrees F. Minimum oil temperature for operation is 60 degrees F.

Figure 2 - Pump And Auxiliary Cooling Package, Part Number 014148

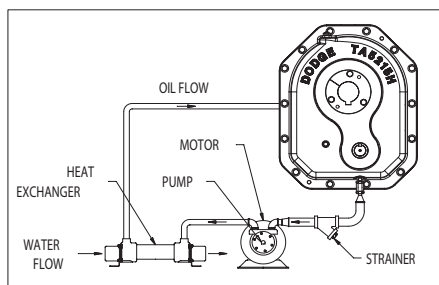

RELATED PRODUCTS



TORQUE-ARM II Shaft Mount Speed Reducers HARSH DUTY ACCESSORIES

XT Safety & Sealing

Metal End Covers ⁽¹⁾ ⁽²⁾

Reducer Size	End Cover Part Numbers			
	Closed	Weight	Split	Weight
TA0107L	900114	0.3	900115	0.3
TA1107H	901114	0.5	901115	0.4
TA2115H	902114	0.6	902115	0.5
TA3203H	903114	1.0	903115	0.6
TA4207H	904114	1.2	904115	1.0
TA5215H	905114	1.3	905115	1.3
TA6307H	906114	1.0	906115	1.5
TA7315H	907114	1.2	907115	1.5
TA8407H	908114	2.5	908115	2.5
TA9415H	909114	4.0	909115	1.7
TA10507H	910114	4.6	910115	3.9
TA12608H	912114	4.8	912115	4.1

- (1) End covers fit both the input side and backstop side of TA II reducer. See Drawing A and Table 3 for dimensions.
- (2) If a TA II Belt Guard is used, an end cover for the input side of the reducer is not needed and will not fit.

Table 3

Reducer Size	A	B	C	D	E	F
TA0107L	7.77	3.63	3.63	2.14	0.22	0.05
TA1107H	7.95	4.13	4.13	2.02	-0.05	-0.22
TA2115H	8.80	4.75	4.75	2.19	0.07	-0.10
TA3203H	9.68	5.25	5.25	3.19	0.08	-0.10
TA4207H	9.95	5.88	5.88	3.21	0.14	-0.04
TA5215H	11.57	6.75	6.75	3.81	0.70	0.46
TA6307H	12.12	6.88	6.88	5.12	0.66	0.41
TA7315H	13.18	8.13	8.13	4.92	0.00	-0.41
TA8407H	14.12	8.38	8.38	5.45	0.19	-0.06
TA9415H	15.17	9.63	9.63	6.37	-0.79	-1.20
TA10507H	16.88	10.63	10.63	6.36	0.00	-0.34
TA12608H	19.75	11.88	11.88	6.47	-0.63	-1.09

Drawing A - Metal End Cover

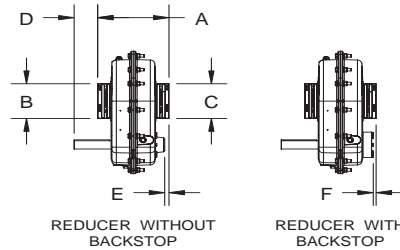

Enclosed Breather Chamber



Oil Sump Heater



Metal End Covers

XT Hostile Environment

Enclosed Breather Chamber

Reducer Size	Part Number
TA0-TA9	240050
TA10-TA12	240051

Filter Breather ⁽³⁾

Reducer Size	Part Number
TA0-TA3	430048
TA4-TA12	430049

Oil Sump Immersion Heaters ⁽³⁾ ⁽⁴⁾

Reducer Size	Part Number
TA0	Not Available
TA1-TA3	241103 ⁽⁴⁾
TA4-TA5	241104 ⁽⁴⁾
TA6-TA12	Consult DODGE ⁽⁴⁾

(3) 110 volt, single phase, AC cartridge heater, threads into special tapped housing hole. Provides for approximately 70 degrees (F) temperatures rise in one hour for cold climates. Simple time phased on/off construction without thermostat.

(4) All TA II reducers have to be factory modified to allow installation of sump heater. Consult DODGE.

(3) 40 micron mesh opening in filter allows reducer to breathe, yet keep dust out, under the most extreme conditions

FEATURES/BENEFITS PAGE G1-3	NOMENCLATURE PAGE G1-8	SELECTION PAGE G1-12	SELECTION/DIMENSION PAGE G1-36
--------------------------------	---------------------------	-------------------------	-----------------------------------



RELATED PRODUCTS

TORQUE-ARM II Shaft Mount Speed Reducers MAXIMUM BORE STRAIGHT BORE TA II REDUCERS

Maximum Bore Straight Bore TA II Reducers ⁽¹⁾ ⁽²⁾ ⁽³⁾

Reducer Size	Max. Bore	TA II Reducer									
		5:1		9:1		15:1		25:1		31:1 - 40:1	
		Part No.	Weight	Part No.	Weight	Part No.	Weight	Part No.	Weight	Part No.	Weight
TA1107H	1-11/16"	901149	56.6	901148	58.0	901147	57.9	901146	57.9	901145	58.0
TA3203H	2-7/16"	903149	109.2	903148	113.3	903147	113.1	903146	112.8	903145	112.0
TA4207H	2-15/16"	904149	182.0	904148	190.7	904147	190.3	904146	189.6	904145	189.0
TA5215H	3-7/16"	905149	262.4	905148	277.0	905147	276.5	905146	275.5	905145	274.7
TA6307H	3-15/16"	906149	316.0	906148	334.0	906147	333.0	906146	331.0	906145	330.0

- (1) See individual reducer catalog pages for accessories for above reducers
- (2) Non-stock, made-to-order reducers
- (3) See Drawing B and Table 4 for catalog dimensions for Maximum Bore Straight Bore TA II Reducers

Drawing B

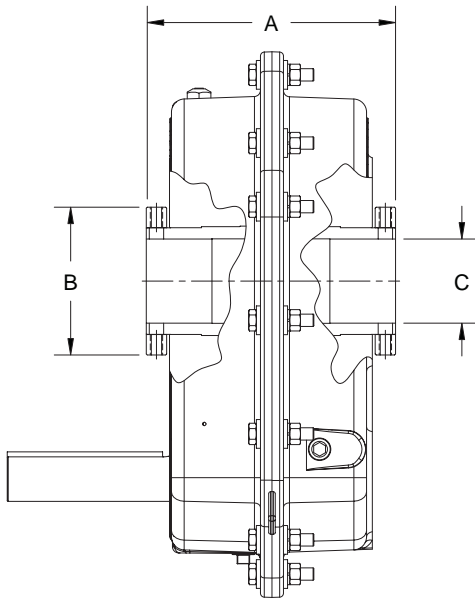

Table 4 ⁽⁴⁾

Reducer Size	A	B	C Bore	Shaft Keyseat Required ⁽⁵⁾
TA1107H	5.82	3.50	1-11/16"	3/8 x 3/16 x 5.81
TA3203H	7.59	4.50	2-7/16"	5/8 x 5/16 x 7.58
TA4207H	8.02	5.00	2-15/16"	3/4 x 3/8 x 8.01
TA5215H	8.97	5.50	3-7/16"	7/8 x 7/16 x 8.96
TA6307H	9.40	5.75	3-15/16"	1 x 1/2 x 9.39

- (4) Always check the driven shaft and key for strength
- (5) Minimum keyseat and shaft length required to mount reducer

FEATURES/BENEFITS PAGE G1-3	NOMENCLATURE PAGE G1-8	SELECTION PAGE G1-12	SELECTION/DIMENSION PAGE G1-36
--------------------------------	---------------------------	-------------------------	-----------------------------------



TORQUE-ARM II Shaft Mount Speed Reducers

NOMINAL SHEAVE RATIOS REQUIRED FOR DODGE TORQUE-ARM II REDUCERS - 5:1, 9:1, 15:1

Reducer Output RPM	5:1 Nominal Reducer Ratio			Reducer Output RPM	9:1 Nominal Reducer Ratio			Reducer Output RPM	15:1 Nominal Reducer Ratio		
	Motor Speed				Motor Speed				Motor Speed		
	1750	1450	1170		1750	1450	1170		1750	1450	1170
400	1.14	1.38	1.71	200	1.03	1.24	1.54	120	1.03	1.24	1.54
395	1.13	1.36	1.69	198	1.02	1.23	1.52	118	1.01	1.22	1.51
390	1.11	1.34	1.67	196	1.01	1.22	1.51	116	1.01	1.20	1.49
385	1.10	1.33	1.65	194	1.00	1.20	1.49	114	1.02	1.18	1.46
380	1.09	1.31	1.62	192	1.01	1.19	1.48	112	1.04	1.16	1.44
375	1.07	1.29	1.60	190	1.02	1.18	1.46	110	1.06	1.14	1.41
370	1.06	1.28	1.58	188	1.03	1.17	1.45	108	1.08	1.12	1.38
365	1.04	1.26	1.56	186	1.05	1.15	1.43	106	1.10	1.10	1.36
360	1.03	1.24	1.54	184	1.06	1.14	1.42	104	1.12	1.08	1.33
355	1.01	1.22	1.52	182	1.07	1.13	1.40	102	1.14	1.06	1.31
350	1.00	1.21	1.50	180	1.08	1.12	1.38	100	1.17	1.03	1.28
345	1.01	1.19	1.47	178	1.09	1.10	1.37	98	1.19	1.01	1.26
340	1.03	1.17	1.45	176	1.10	1.09	1.35	96	1.22	1.01	1.23
335	1.04	1.16	1.43	174	1.12	1.08	1.34	94	1.24	1.03	1.21
330	1.06	1.14	1.41	172	1.13	1.07	1.32	92	1.27	1.05	1.18
325	1.08	1.12	1.39	170	1.14	1.06	1.31	90	1.30	1.07	1.15
320	1.09	1.10	1.37	168	1.16	1.04	1.29	88	1.33	1.10	1.13
315	1.11	1.09	1.35	166	1.17	1.03	1.28	86	1.36	1.12	1.10
310	1.13	1.07	1.32	164	1.19	1.02	1.26	84	1.39	1.15	1.08
305	1.15	1.05	1.30	162	1.20	1.01	1.25	82	1.42	1.18	1.05
300	1.17	1.03	1.28	160	1.22	1.01	1.23	80	1.46	1.21	1.03
295	1.19	1.02	1.26	158	1.23	1.02	1.22	78	1.50	1.24	1.00
290	1.21	1.00	1.24	156	1.25	1.03	1.20	76	1.54	1.27	1.03
285	1.23	1.02	1.22	154	1.26	1.05	1.18	74	1.58	1.31	1.05
280	1.25	1.04	1.20	152	1.28	1.06	1.17	72	1.62	1.34	1.08
275	1.27	1.05	1.18	150	1.30	1.07	1.15	70	1.67	1.38	1.11
270	1.30	1.07	1.15	148	1.31	1.09	1.14	68	1.72	1.42	1.15
265	1.32	1.09	1.13	146	1.33	1.10	1.12	66	1.77	1.46	1.18
260	1.35	1.12	1.11	144	1.35	1.12	1.11	64	1.82	1.51	1.22
255	1.37	1.14	1.09	142	1.37	1.13	1.09	62	1.88	1.56	1.26
250	1.40	1.16	1.07	140	1.39	1.15	1.08	60	1.94	1.61	1.30
245	1.43	1.18	1.05	138	1.41	1.17	1.06	58	2.01	1.67	1.34
240	1.46	1.21	1.03	136	1.43	1.18	1.05	56	2.08	1.73	1.39
235	1.49	1.23	1.00	134	1.45	1.20	1.03	54	2.16	1.79	1.44
230	1.52	1.26	1.02	132	1.47	1.22	1.02	52	2.24	1.86	1.50
225	1.56	1.29	1.04	130	1.50	1.24	1.00	50	2.33	1.93	1.56
220	1.59	1.32	1.06	128	1.52	1.26	1.02	48	2.43	2.01	1.63
215	1.63	1.35	1.09	126	1.54	1.28	1.03	46	2.54	2.10	1.70
210	1.67	1.38	1.11	124	1.57	1.30	1.05	44	2.65	2.20	1.77
205	1.71	1.41	1.14	122	1.59	1.32	1.07	42	2.78	2.30	1.86
200	1.75	1.45	1.17	120	1.62	1.34	1.08	40	2.92	2.42	1.95
195	1.79	1.49	1.20	118	1.65	1.37	1.10	38	3.07	2.54	2.05
190	1.84	1.53	1.23	116	1.68	1.39	1.12	36	3.24	2.69	2.17
185	1.89	1.57	1.26	114	1.71	1.41	1.14	34	3.43	2.84	2.29
180	1.94	1.61	1.30	112	1.74	1.44	1.16	32	3.65	3.02	2.44
175	2.00	1.66	1.34	110	1.77	1.46	1.18	30	3.89	3.22	2.60
170	2.06	1.71	1.38	108	1.80	1.49	1.20	28	4.17	3.45	2.79
165	2.12	1.76	1.42	106	1.83	1.52	1.23	26	4.49	3.72	3.00
160	2.19	1.81	1.46	104	1.87	1.55	1.25	24	4.86	4.03	3.25
155	2.26	1.87	1.51	102	1.91	1.58	1.27	22	5.30	4.39	3.55
150	2.33	1.93	1.56	100	1.94	1.61	1.30	20	5.83	4.83	3.90
145	2.41	2.00	1.61					18	6.48	5.37	4.33
140	2.50	2.07	1.67					16	7.29	6.04	4.88
135	2.59	2.15	1.73					14	8.33	6.90	5.57
130	2.69	2.23	1.80					12	9.72	8.06	6.50
125	2.80	2.32	1.87					10	11.67	9.67	7.80
120	2.92	2.42	1.95								
115	3.04	2.52	2.03								
110	3.18	2.64	2.13								
105	3.33	2.76	2.23								
100	3.50	2.90	2.34								

Note: Speed increase ratios are shown in bold type

FEATURES/BENEFITS PAGE G1-3	NOMENCLATURE PAGE G1-8	SELECTION PAGE G1-12	SELECTION/DIMENSION PAGE G1-36
--------------------------------	---------------------------	-------------------------	-----------------------------------



RELATED PRODUCTS

TORQUE-ARM II Shaft Mount Speed Reducers

NOMINAL SHEAVE RATIOS REQUIRED FOR DODGE TORQUE-ARM II REDUCERS -

25:1, 31-32-33:1, 40:1

Reducer Output RPM	25:1 Nominal Reducer Ratio			Reducer Output RPM	31:1, 32:1 and 33:1 Nominal Reducer Ratios			Reducer Output RPM	40:1 Nominal Reducer Ratio		
	Motor Speed				Motor Speed				Motor Speed		
	1750	1450	1170		1750	1450	1170		1750	1450	1170
80	1.14	1.38	1.71	50	1.09	1.10	1.37	50	1.14	1.38	1.71
78	1.11	1.34	1.67	48	1.14	1.06	1.31	48	1.10	1.32	1.64
76	1.09	1.31	1.62	46	1.19	1.02	1.26	46	1.05	1.27	1.57
74	1.06	1.28	1.58	44	1.24	1.03	1.20	44	1.01	1.21	1.50
72	1.03	1.24	1.54	42	1.30	1.08	1.15	42	1.04	1.16	1.44
70	1.00	1.21	1.50	40	1.37	1.13	1.09	40	1.09	1.10	1.37
68	1.03	1.17	1.45	38	1.44	1.19	1.04	38	1.15	1.05	1.30
66	1.06	1.14	1.41	36	1.52	1.26	1.02	36	1.22	1.01	1.23
64	1.09	1.10	1.37	34	1.61	1.33	1.08	34	1.29	1.07	1.16
62	1.13	1.07	1.32	32	1.71	1.42	1.14	32	1.37	1.13	1.09
60	1.17	1.03	1.28	30	1.82	1.51	1.22	30	1.46	1.21	1.03
58	1.21	1.00	1.24	28	1.95	1.62	1.31	28	1.56	1.29	1.04
56	1.25	1.04	1.20	26	2.10	1.74	1.41	26	1.68	1.39	1.13
54	1.30	1.07	1.15	24	2.28	1.89	1.52	24	1.82	1.51	1.22
52	1.35	1.12	1.11	22	2.49	2.06	1.66	22	1.99	1.65	1.33
50	1.40	1.16	1.07	20	2.73	2.27	1.83	20	2.19	1.81	1.46
48	1.46	1.21	1.03	18	3.04	2.52	2.03	18	2.43	2.01	1.63
46	1.52	1.26	1.02	16	3.42	2.83	2.29	16	2.73	2.27	1.83
44	1.59	1.32	1.06	14	3.91	3.24	2.61	14	3.13	2.59	2.09
42	1.67	1.38	1.11	12	4.56	3.78	3.05	12	3.65	3.02	2.44
40	1.75	1.45	1.17	10	5.47	4.53	3.66	10	4.38	3.63	2.93
38	1.84	1.53	1.23	8	6.84	5.66	4.57	8	5.47	4.53	3.66
36	1.94	1.61	1.30	6	9.11	7.55	6.09	6	7.29	6.04	4.88
34	2.06	1.71	1.38								
32	2.19	1.81	1.46								
30	2.33	1.93	1.56								
28	2.50	2.07	1.67								
26	2.69	2.23	1.80								
24	2.92	2.42	1.95								
22	3.18	2.64	2.13								
20	3.50	2.90	2.34								
18	3.89	3.22	2.60								
16	4.38	3.63	2.93								
14	5.00	4.14	3.34								
12	5.83	4.83	3.90								
10	7.00	5.80	4.68								
8	8.75	7.25	5.85								
6	11.67	9.67	7.80								

RELATED PRODUCTS



TORQUE-ARM II Shaft Mount Speed Reducers

NOMINAL SHEAVE SPEED (RPM) AT INPUT FOR DODGE REDUCERS - 1750 MOTOR

Reducer Output RPM	5:1 Nominal Reducer Ratio	Reducer Output RPM	9:1 Nominal Reducer Ratio	Reducer Output RPM	15:1 Nominal Reducer Ratio	Reducer Output RPM	25:1 Nominal Reducer Ratio	Reducer Output RPM	31:1, 32:1 and 33:1 Nominal Reducer Ratios	Reducer Output RPM	40:1 Nominal Reducer Ratio
400	2000	200	1800	120	1800	80	2000	50	1600	50	2000
395	1975	198	1782	118	1770	78	1950	48	1536	48	1920
390	1950	196	1764	116	1740	76	1900	46	1472	46	1840
385	1925	194	1746	114	1710	74	1850	44	1408	44	1760
380	1900	192	1728	112	1680	72	1800	42	1344	42	1680
375	1875	190	1710	110	1650	70	1750	40	1280	40	1600
370	1850	188	1692	108	1620	68	1700	38	1216	38	1520
365	1825	186	1674	106	1590	66	1650	36	1152	36	1440
360	1800	184	1656	104	1560	64	1600	34	1088	34	1360
355	1775	182	1638	102	1530	62	1550	32	1024	32	1280
350	1750	180	1620	100	1500	60	1500	30	960	30	1200
345	1725	178	1602	98	1470	58	1450	28	896	28	1120
340	1700	176	1584	96	1440	56	1400	26	832	26	1040
335	1675	174	1566	94	1410	54	1350	24	768	24	960
330	1650	172	1548	92	1380	52	1300	22	704	22	880
325	1625	170	1530	90	1350	50	1250	20	640	20	800
320	1600	168	1512	88	1320	48	1200	18	576	18	720
315	1575	166	1494	86	1290	46	1150	16	512	16	640
310	1550	164	1476	84	1260	44	1100	14	448	14	560
305	1525	162	1458	82	1230	42	1050	12	384	12	480
300	1500	160	1440	80	1200	40	1000	10	320	10	400
295	1475	158	1422	78	1170	38	950	8	256	8	320
290	1450	156	1404	76	1140	36	900	6	192	6	240
285	1425	154	1386	74	1110	34	850				
280	1400	152	1368	72	1080	32	800				
275	1375	150	1350	70	1050	30	750				
270	1350	148	1332	68	1020	28	700				
265	1325	146	1314	66	990	26	650				
260	1300	144	1296	64	960	24	600				
255	1275	142	1278	62	930	22	550				
250	1250	140	1260	60	900	20	500				
245	1225	138	1242	58	870	18	450				
240	1200	136	1224	56	840	16	400				
235	1175	134	1206	54	810	14	350				
230	1150	132	1188	52	780	12	300				
225	1125	130	1170	50	750	10	250				
220	1100	128	1152	48	720	8	200				
215	1075	126	1134	46	690	6	150				
210	1050	124	1116	44	660						
205	1025	122	1098	42	630						
200	1000	120	1080	40	600						
195	975	118	1062	38	570						
190	950	116	1044	36	540						
185	925	114	1026	34	510						
180	900	112	1008	32	480						
175	875	110	990	30	450						
170	850	108	972	28	420						
165	825	106	954	26	390						
160	800	104	936	24	360						
155	775	102	918	22	330						
150	750	100	900	20	300						
145	725			18	270						
140	700			16	240						
135	675			14	210						
130	650			12	180						
125	625			10	150						
120	600										
115	575										
110	550										
105	525										
100	500										

Gearing Reference Guide

TORQUE-ARM II

TORQUE-ARM

MAXIMUM Concentric Reducer

TIGEAR-2

FEATURES/BENEFITS PAGE G1-3	NOMENCLATURE PAGE G1-8	SELECTION PAGE G1-12	SELECTION/DIMENSION PAGE G1-36
--------------------------------	---------------------------	-------------------------	-----------------------------------

RENEWAL PARTS



TORQUE-ARM II Shaft Mount Speed Reducers RENEWAL PARTS FOR TA II REDUCERS

Torque-Arm II Bearing Kits ⁽¹⁾

Size	Ratio	Kit P/N	Size	Ratio	Kit P/N
TA0107L	5:1	900128	TA6307H	5:1	906128
TA0107L	9:1 - 40:1	900129	TA6307H	9:1 - 15:1	906129
TA1107H	5:1	901128	TA6307H	25:1 - 40:1	906130
TA1107H	9:1 - 15:1	901129	TA7315H	5:1	907128
TA1107H	25:1 - 40:1	901130	TA7315H	9:1 - 25:1	907129
TA2115H	5:1	902128	TA7315H	40:1	907130
TA2115H	9:1 - 25:1	902129	TA8407H	15:1 - 25:1	908129
TA2115H	40:1	902130	TA8407H	40:1	908130
TA3203H	5:1	903128	TA9415H	15:1 - 25:1	909129
TA3203H	9:1 - 25:1	903129	TA9415H	40:1	909130
TA3203H	40:1	903130	TA10507H	15:1 - 25:1	910129
TA4207H	5:1	904128	TA10507H	40:1	910130
TA4207H	9:1 - 25:1	904129	TA12608H	15:1 - 25:1	912129
TA4207H	40:1	904130	TA12608H	40:1	912130
TA5215H	5:1	905128			
TA5215H	9:1 - 15:1	905129			
TA5215H	25:1	905130			
TA5215H	40:1	905131			

(1) Kit contains complete set of bearings for reducer size and ratio indicated.

Torque-Arm II Level I Rebuild Kits ⁽³⁾

Size	Ratio	Kit P/N	Size	Ratio	Kit P/N
TA0107L	5:1	900135	TA6307H	5:1	906135
TA0107L	9:1 - 40:1	900136	TA6307H	9:1 - 15:1	906136
TA1107H	5:1	901135	TA6307H	25:1 - 40:1	906137
TA1107H	9:1 - 15:1	901136	TA7315H	5:1	907135
TA1107H	25:1 - 40:1	901137	TA7315H	9:1 - 25:1	907136
TA2115H	5:1	902135	TA7315H	40:1	907137
TA2115H	9:1 - 25:1	902136	TA8407H	15:1 - 25:1	908136
TA2115H	40:1	902137	TA8407H	40:1	908137
TA3203H	5:1	903135	TA9415H	15:1 - 25:1	909136
TA3203H	9:1 - 25:1	903136	TA9415H	40:1	909137
TA3203H	40:1	903137	TA10507H	15:1 - 25:1	910136
TA4207H	5:1	904135	TA10507H	40:1	910137
TA4207H	9:1 - 25:1	904136	TA12608H	15:1 - 25:1	912136
TA4207H	40:1	904137	TA12608H	40:1	912137
TA5215H	5:1	905135			
TA5215H	9:1 - 15:1	905136			
TA5215H	25:1	905137			
TA5215H	40:1	905138			

(3) Level 1 Rebuild Kit includes input & output seals, all bearings, shims and sealant for reducer size and ratio indicated. Level II protection can be provided by stocking an input shaft with pinion and a first reduction gear, along with a Level I Rebuild Kit from the above list. See Instruction Manual # 499385 for gearing part numbers.

Torque-Arm II Seal Kits ⁽²⁾

Size	Ratio	Kit P/N
TA0107L	All	900126
TA1107H	All	901126
TA2115H	5:1 - 25:1	902126
TA2115H	40:1	902127
TA3203H	5:1-25:1	903126
TA3203H	40:1	903127
TA4207H	All	904126
TA5215H	All	905126
TA6307H	All	906126
TA7315H	All	907126
TA8407H	All	908126
TA9415H	All	909126
TA10507	All	910126
TA12608	All	912126

(2) Kit includes input & output seals, backstop cover gasket and RTV sealant for reducer size and ratio indicated

Torque-Arm II Shim Kits ⁽⁴⁾

Size	Shim Output Brg	Shim Input Brg	Shim Coshaft Brg
TA0107L	900132	901134	900134
TA1107H	901132	901133	901134
TA2115H	902132	902133	901133
TA3203H	903132	903134	903134
TA4207H	904132	903134	903134
TA5215H	905132	905133	905133
TA6307H	906132	906133	906133
TA7315H	907132	907133	906133
TA8407H	907132	903132	908134
TA9415H	909132	909134	909134
TA10507H	910132	910133	904132
TA12608H	912132	910133	912134

(4) Kit contains complete set of shims for reducer size and location indicated.



TORQUE-ARM II Shaft Mount Speed Reducers

Table 1: NEMA Motor Information (1750 RPM)

Horsepower	NEMA Motor Frame	Shaft Diameter
1	143T	7/8
1-1/2	145T	7/8
2	145T	7/8
3	182T	1-1/8
5	184T	1-1/8
7-1/2	213T	1-3/8
10	215T	1-3/8
15	254T	1-5/8
20	256T	1-5/8
25	284T	1-7/8
30	286T	1-7/8
40	324T	2-1/8
50	326T	2-1/8
60	364T	2-3/8
75	365T	2-3/8
100	+405T	2-7/8
125	+444T	3-3/8
150	+445T	3-3/8
200	+447T	3-3/8

+ Energy Efficient (TEFC-XE) Frame

Table 2: TORQUE-ARM II Reducer Information

TA II Reducer	Ratio	Input Shaft Diameter	Minimum Sheave Diameter
TA0107L	All	1"	See Class I, II and III Selection Tables for minimum reducer sheave recommendations
TA1107H	All	1"	
TA2115H	5:1 - 25:1 33:1	1-1/8" 1"	
TA3203H	5:1 - 25:1 32:1	1-3/8" 1-1/8"	
TA4207H	All	1-7/16"	
TA5215H	All	1-5/8"	
TA6307H	All	2-3/16"	
TA7315H	All	2-7/16"	
TA8407H	All	2-7/16"	
TA9415H	All	2-7/16"	
TA10507H	All	2-11/16"	
TA12608H	All	2-11/16"	

Table 3: TORQUE-ARM II Backstop

Lift-off Speed ⁽¹⁾

TA II Reducer	Minimum Input Shaft RPM
TA0107L	875
TA1107H	875
TA2115H	875
TA3203H	825
TA4207H	780
TA5215H	720
TA6307H	610
TA7315H	490
TA8407H	610
TA9415H	490
TA10507H	480
TA12608H	450

⁽¹⁾ For best results, select reducer ratios which exceed input shaft speeds required for backstop sprag lift-off

FEATURES/BENEFITS PAGE G1-3	NOMENCLATURE PAGE G1-8	SELECTION PAGE G1-12	SELECTION/DIMENSION PAGE G1-36
--------------------------------	---------------------------	-------------------------	-----------------------------------



ENGINEERING/TECHNICAL

TORQUE-ARM II Shaft Mount Speed Reducers

Maximum Input Speed - RPM

Case Size	Nominal Ratio				
	05	09	15	25	32/40
TA0107L	2080	1800	1791	2007	1750
TA1107H	2000	1798	1789	2005	1750
TA2115H	2080	1821	1874	2005	1750
TA3203H	1965	1847	1808	1996	1750
TA4207H	2000	1846	1800	2010	1955
TA5215H	2042	1837	1791	2000	1945
TA6307H	1978	1843	1854	1989	1916
TA7315H	2075	1943	1790	1987	1983
TA8407H	N/A	N/A	1814	1997	1983
TA9415H	N/A	N/A	1812	2035	1970
TA10507H	N/A	N/A	1811	2015	1984
TA12608H	N/A	N/A	1775	2002	1909

Maximum Output Speed - RPM

Case Size	Nominal Ratio				
	05	09	15	25	32/40
TA0107L	400	200	120	80	57
TA1107H	400	200	120	80	57
TA2115H	400	200	120	80	53
TA3203H	400	200	120	80	54
TA4207H	400	200	120	80	50
TA5215H	400	200	120	80	50
TA6307H	400	200	120	80	50
TA7315H	400	200	120	80	50
TA8407H	N/A	N/A	120	80	50
TA9415H	N/A	N/A	120	80	50
TA10507H	N/A	N/A	120	80	50
TA12608H	N/A	N/A	120	80	50



TORQUE-ARM II Shaft Mount Speed Reducers

Thrust Capacity for Screw Conveyor Drives (Pounds)

Case Size	Output Speed (RPM) Single Reduction Reducers (05:1)						
	100	150	200	250	300	350	400
TA0107L	2568	2288	2092	2000	1922	1855	1798
TA1107H	3106	2835	2626	2505	2396	2309	2232
TA2115H	5373	4771	4417	4186	4015	3885	3785
TA3203H	6000	5834	5387	5053	4783	4561	4386
TA4207H	6000	6000	6000	6000	6000	5776	5570
TA5215H	6000	6000	6000	6000	6000	6000	6000
TA6307H	6000	5803	5374	5202	4977	4807	4737
TA7315H	†	†	†	†	†	†	†

Thrust Capacity for Screw Conveyor Drives (Pounds)

Case Size	Output Speed (RPM) Double Reduction Reducers (09:1 thru 40:1)								
	10	25	50	75	100	125	150	175	200
TA0107L	5300	4028	3141	2730	2465	2281	2165	2071	1989
TA1107H	6000	4833	3705	3196	2865	2639	2568	2438	2315
TA2115H	6000	6000	6000	5323	4850	4550	4295	4086	3924
TA3203H	6000	6000	6000	6000	5761	5328	5020	4813	4636
TA4207H	6000	6000	6000	6000	6000	6000	6000	6000	6000
TA5215H	6000	6000	6000	6000	6000	6000	6000	6000	6000
TA6307H	6000	6000	6000	5885	5185	4706	4435	4303	4269
TA7315H	†	†	†	†	†	†	†	†	†

† Consult DODGE

ENGINEERING/TECHNICAL



TORQUE-ARM II Shaft Mount Speed Reducers

LUBRICATION OF TORQUE-ARM II REDUCERS

CAUTION: Unit is shipped without oil. Add proper amount of rust and oxidation inhibited (R & O) gear oil before operating. Follow instructions on reducer warning tags and in the instruction manual. Failure to observe these precautions could result in damage to, or destruction of, the equipment.

WARNING: To ensure that drive is not unexpectedly started, turn off and lock out or tag power source before proceeding. Remove all external loads from drive before removing or servicing drive or accessories. Failure to observe these precautions could result in bodily injury.

Lubrication is extremely important for satisfactory operation. The proper oil level as shown in Table 3 on page 135, showing oil level plug location, must be maintained at all times. Approximate oil quantities are shown in Table 4 on page 136. Frequent inspections with the unit not running and allowing sufficient time for the oil to cool and the entrapped air to settle out of the oil should be made by removing the level plug to see that the level is being maintained. If low, add the proper type and viscosity of lubricant through one of the upper openings until it comes out of the oil level hole. Replace the oil level plug securely. Refer to Tables 1 and 2 for viscosity recommendations. After an initial operation of about two weeks, the oil should be changed. If desired, this oil may be filtered and reused. Very often, small metal particles will show up in the oil due to the wearing process. After the initial break in period, the lubricant should be drained, magnetic drain plug cleaned, gear case flushed and refilled every 2500

hours of operation under average industrial operating conditions.

CAUTION: Too much oil will cause overheating and too little will result in gear failure. Check oil level regularly.

More frequent oil changes are recommended when operating continuously or at high temperatures or under conditions of extreme dirt or dust. Use only recommended grades of lubricant listed on next page, or equivalent. Special attention should be given to checking of lubricants when any of the following conditions exist:

- High operating temperatures resulting from heavy intermittent loads causes the temperature of the gear case to rise rapidly and then cool

- Unusual ambient conditions, which may tend to cause condensation on the inside of the gearcase thereby contaminating the oil

- Operating temperatures that would cause oil to approach 200°F continually

- Subjection of reducer to unusual vapors or moist atmosphere

- Subjection of reducer to extremely dusty or dirty environment

Under these extreme operating conditions, the oil should be changed every 1 to 3 months depending on severity of conditions.

Operating Temperatures

Heating is a natural characteristic of enclosed gearing, and a maximum gear case temperature approaching 200°F is not uncommon for some units operating in normal ambient temperatures (80°F). When operating at rated capacity, no damage will result from this temperature as this was taken into consideration in the design of the gear case and in the selection of the lubricants.



TORQUE-ARM II Shaft Mount Speed Reducers LUBRICATION OF TORQUE-ARM II REDUCERS (CONT'D)

Table 1 – Oil Recommendations

ISO Grades For Ambient Temperatures of 50°F to 125°F

Output RPM	Torque-Arm II Reducer Size											
	TA0107L	TA1107H	TA2115H	TA3203H	TA4207H	TA5215H	TA6307H	TA7315H	TA8407H	TA9415H	TA10507H	TA12608H
301 – 400	320	320	320	220	220	220	220	220	220	220	220	220
201 – 300	320	320	320	220	220	220	220	220	220	220	220	220
151 – 200	320	320	320	220	220	220	220	220	220	220	220	220
126 – 150	320	320	320	220	220	220	220	220	220	220	220	220
101 – 125	320	320	320	320	220	220	220	220	220	220	220	220
81 – 100	320	320	320	320	320	220	220	220	220	220	220	220
41 – 80	320	320	320	320	320	220	220	220	220	220	220	220
11 – 40	320	320	320	320	320	320	320	320	320	320	220	220
1 – 10	320	320	320	320	320	320	320	320	320	320	320	320

Table 2 – Oil Recommendations

ISO Grades For Ambient Temperatures of 15°F to 60°F

Output RPM	Torque-Arm II Reducer Size											
	TA0107L	TA1107H	TA2115H	TA3203H	TA4207H	TA5215H	TA6307H	TA7315H	TA8407H	TA9415H	TA10507H	TA12608H
301 – 400	220	220	220	150	150	150	150	150	150	150	150	150
201 – 300	220	220	220	150	150	150	150	150	150	150	150	150
151 – 200	220	220	220	150	150	150	150	150	150	150	150	150
126 – 150	220	220	220	150	150	150	150	150	150	150	150	150
101 – 125	220	220	220	220	150	150	150	150	150	150	150	150
81 – 100	220	220	220	220	220	150	150	150	150	150	150	150
41 – 80	220	220	220	220	220	150	150	150	150	150	150	150
11 – 40	220	220	220	220	220	220	220	220	220	220	150	150
1 – 10	220	220	220	220	220	220	220	220	220	220	220	220

NOTES:

- Assumes auxiliary cooling where recommended in the catalog.
- Pour point of lubricant selected should be at least 10°F lower than expected minimum ambient starting temperature.
- Extreme pressure (EP) lubricates are not necessary for average operating conditions. When properly selected for specific applications, TORQUE-ARM II backstops are suitable for use with EP lubricants.
- Special lubricants may be required for food and drug industry applications where contact with the product being manufactured may occur.
Consult a lubrication manufacturer's representative for his recommendations.
- For reducers operating in ambient temperatures between -22°F (-30°C) and 20°F (-6.6°C) use a synthetic hydrocarbon lubricant, 100 ISO grade or AGMA 3 grade (for example, Mobil SHC627). Above 125°F (51°C), consult DODGE Gear Application Engineering (864) 288-9050 for lubrication recommendation.
- Mobil SHC630 Series oil is recommended for high ambient temperatures.

FEATURES/BENEFITS PAGE G1-3	NOMENCLATURE PAGE G1-8	SELECTION PAGE G1-12	SELECTION/DIMENSION PAGE G1-36
--------------------------------	---------------------------	-------------------------	-----------------------------------



ENGINEERING/TECHNICAL

TORQUE-ARM II Shaft Mount Speed Reducers

LUBRICATION OF TORQUE-ARM II REDUCERS (CONT'D)

LUBRICANT GRADE EQUIVALENTS •

ISO	AGMA
150	4
220	5
320	6

- See page G1-135 for complete lubricant interchange chart

INSTALLATION

Horizontal Installations - Install the magnetic drain plug in the hole closest to the bottom of the reducer. Throw away the tape that covers the filter/ventilation plug in shipment and install plug in topmost hole. Of the 2 remaining plugs on the sides of the reducer, the lowest one is the minimum oil level plug.

Vertical Installations - Install the filter/ventilation plug in the hole provided in the upper face of the reducer housing as installed. If space is restricted on the upper face, install the vent in the highest hole on the side of the reducer per Figure 1. Install a plug in the hole in the bottom face of the reducer. Do not use this hole for the magnetic drain plug. Of the remaining holes on the sides of the reducer, use the plug in the upper housing half for the minimum oil level plug.

Mounting Position - The running position of the reducer in the horizontal application is not limited to the four positions shown in Figure 1. However, if the running position is over 20° off of position "B" or "D" or 5° off of position "A" or "C", either way from the sketches, the oil level plug cannot be used to safely check the oil level, unless during the checking, the torque arm is disconnected and the reducer is swung to within 20° for position "A" and "C" or 5° for position "B" and "D" of the positions shown in Figure 1. Because of the many possible positions, of the reducer, it may be

necessary or desirable to make special adaptations using the lubrication filling holes furnished along with other standard pipe fittings, stand pipes and oil level gauges as required.

Figure 1

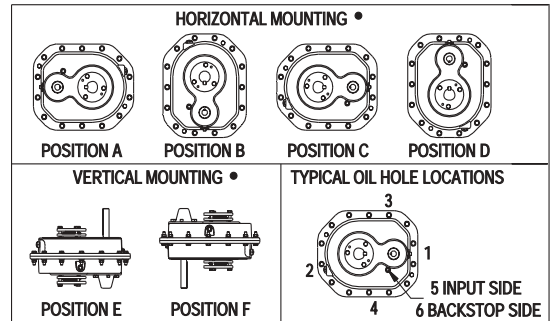

- Below 15 RPM output speed, oil level must be adjusted to reach the highest oil level plug. If reducer position is to vary from those shown in Figure 1, either more or less oil may be required. Consult DODGE.

FEATURES/BENEFITS PAGE G1-3	NOMENCLATURE PAGE G1-8	SELECTION PAGE G1-12	SELECTION/DIMENSION PAGE G1-36
--------------------------------	---------------------------	-------------------------	-----------------------------------



TORQUE-ARM II Shaft Mount Speed Reducers

LUBRICATION OF TORQUE-ARM II REDUCERS (CONT'D)

Table 3 - Vent and Plug Locations (See Figure 1, page G1-134)

Mounting Position	Output Speed Above 15 RPM						Output Speed 15 RPM and Below [●]					
	Vent and Plug Locations						Vent and Plug Locations					
	1	2	3	4	5	6	1	2	3	4	5	6
Position A	Level	Plug	Drain	Vent	Plug	Plug	Plug	Level	Drain	Vent	Plug	Plug
Position B	Drain	Vent	Level	Plug	Plug	Plug	Drain	Vent	Plug	Level	Plug	Plug
Position C	Plug	Level	Vent	Drain	Plug	Plug	Level	Plug	Vent	Drain	Plug	Plug
Position D	Vent	Drain	Level	Plug	Plug	Plug	Vent	Drain	Level	Plug	Plug	Plug
Position E	Level	* Plug	Plug	Drain	Vent	Plug	Level	* Plug	Plug	Drain	Vent	Plug
Position F	Plug	Drain	Level	* Plug	Plug	Vent	Plug	Drain	Level	* Plug	Plug	Vent

* Where space constraints prevent installing the breather in vent locations 5 or 6, install vent in this location and order a vertical breather kit

● Below 15 RPM output speed, oil level must be adjusted to reach the highest oil level plug. If reducer position is to vary from those shown in Figure 1, either more or less oil may be required. Consult DODGE.

RECOMMENDED LUBRICANTS FOR TORQUE-ARM II REDUCERS +			
Standard Oils		EP Oils	
EXXON			
150	Teresstic	150	Spartan EP 150
220		220	220
320		320	320
CHEVRON			
150	Machine	150	Gear Compound 150
220		220	EP 220
320		320	320
UNICAL			
150	Turbine Oil	150	Extra Duty HL 141
220		220	Gear Lube 207
320		320	300
MOBIL SYNTHETIC			
150	SHC	629	SHC 629
220	SHC	630	SHC 630
320	SHC	632	SHC 632
MOBIL			
150	Mobil DTE	BB	Mobil Gear 629
220	Extra Heavy	AA	630
320			632
TEXACO			
150	Regal Oil R&O	150	Meropa 150
220		220	220
320		320	320
SHELL			
150	Morlina Oil	150	Omala 150
220		220	220
320		320	320

+Partial list. Consult DODGE or a lubricant manufacturer for further options.

FEATURES/BENEFITS PAGE G1-3	NOMENCLATURE PAGE G1-8	SELECTION PAGE G1-12	SELECTION/DIMENSION PAGE G1-36
--------------------------------	---------------------------	-------------------------	-----------------------------------



ENGINEERING/TECHNICAL

TORQUE-ARM II Shaft Mount Speed Reducers LUBRICATION OF TORQUE-ARM II REDUCERS (CONT'D)

Table 4 - Oil Volumes

Case Size	Ratios	Oil Volume in Quarts † ■ ▲ ●						Oil Volume in Liters † ■ ▲ ●					
		Horizontal				Vertical		Horizontal				Vertical	
		A	B	C	D	E (Up)	F (Down)	A	B	C	D	E (Up)	F (Down)
TA0107L	Single	0.7	0.5	0.7	1.4	1.3	1.5	0.6	0.5	0.6	1.3	1.2	1.4
	Doubles	0.7	0.5	0.6	1.3	1.2	1.4	0.6	0.5	0.6	1.3	1.2	1.3
TA1107H	Single	1.3	0.7	0.7	1.7	1.5	1.9	1.3	0.7	0.6	1.6	1.4	1.8
	Doubles	1.3	0.7	0.6	1.7	1.5	1.9	1.3	0.7	0.6	1.6	1.4	1.8
TA2115H	Single	2.1	1.2	1.1	2.7	2.3	3.1	2.0	1.2	1.0	2.5	2.2	2.9
	Doubles	2.1	1.1	1.0	2.6	2.4	3.0	2.0	1.1	1.0	2.5	2.3	2.8
TA3203H	Single	2.8	1.6	1.8	4.1	3.3	4.4	2.7	1.6	1.7	3.9	3.1	4.2
	Doubles	2.8	1.5	1.7	4.0	3.4	4.2	2.7	1.4	1.6	3.8	3.3	4.0
TA4207H	Single	4.4	2.6	2.9	7.4	6.3	7.8	4.2	2.5	2.8	7.0	6.0	7.3
	Doubles	4.4	2.5	2.8	7.3	6.4	7.5	4.2	2.4	2.6	6.9	6.0	7.1
TA5215H	Single	7.4	4.9	5.8	13.2	11.6	13.1	7.0	4.7	5.5	12.5	11.0	12.4
	Doubles	7.4	4.7	5.5	12.9	11.4	12.6	7.0	4.4	5.2	12.2	10.8	11.9
TA6307H	Single	8.8	5.8	6.6	16.1	13.2	16.1	8.4	5.5	6.2	15.3	12.5	15.3
	Doubles	8.8	5.5	6.2	15.8	13.9	15.3	8.4	5.2	5.9	15.0	13.1	14.5
TA7315H	Single	8.4	11.8	13.9	22.5	22.1	25.1	8.0	11.1	13.2	21.3	20.9	23.7
	Doubles	8.4	10.8	13.2	22.0	22.4	23.1	8.0	10.3	12.5	20.9	21.2	21.8
TA8407H	Doubles	7.7	11.7	13.7	25.1	24.0	25.8	7.3	11.1	12.9	23.8	22.7	24.4
TA9415H	Doubles	17.0	16.8	18.1	33.2	33.2	38.6	16.1	15.9	17.1	31.4	31.4	36.5
TA10507H	Doubles	38.0	27.6	25.8	53.5	53.8	56.1	36.0	26.1	24.4	50.6	50.9	53.0
TA12608H	Doubles	53.0	41.5	37.1	70.7	72.2	80.4	50.2	39.3	35.1	66.9	68.3	76.1

■ Oil quantity is approximate. Service with lubricant until oil runs out of oil level hole

† Refer to Figure 1 for mounting positions

▲ US measure: 1 quart = 32 fluid ounces = .94646 liters

● Below 15 RPM output speed, oil level must be adjusted to reach the highest oil level plug. If reducer position is to vary from those shown in Figure 1, either more or less oil may be required. Consult DODGE.



TORQUE-ARM II Shaft Mount Speed Reducers

VISCOSITY CLASSIFICATION EQUIVALENTS

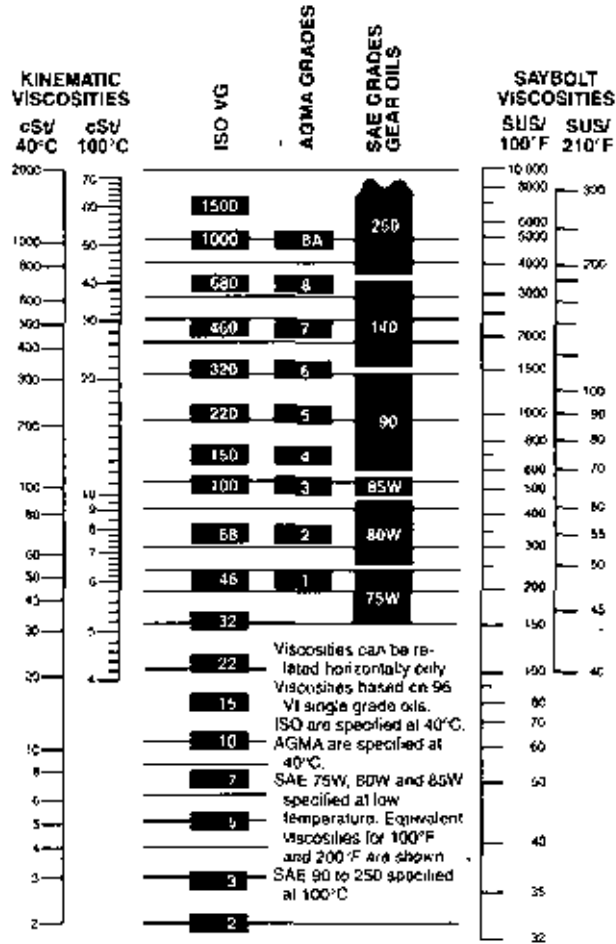

ISO VISCOSITY CLASSIFICATION SYSTEM

All industrial oils are graded according to the ISO Viscosity Classification System, approved by the International Standards Organizations (ISO). Each ISO viscosity grade number corresponds to the mid-point of viscosity range expressed in centistokes (cSt) at 40C. For example, a lubricant with an ISO grade of 32 has a viscosity within the range of 28.80-35.2, the midpoint of which is 32.

Rule-of-Thumb: The comparable ISO grade of a competitive product whose viscosity in SUS at 1005F is known can be determined by using the following conversion formula:

$$\text{SUS @ 100°F} \div 5 = \text{cSt @ 40°C}$$

FEATURES/BENEFITS PAGE G1-3	NOMENCLATURE PAGE G1-8	SELECTION PAGE G1-12	SELECTION/DIMENSION PAGE G1-36
--------------------------------	---------------------------	-------------------------	-----------------------------------

ENGINEERING/TECHNICAL



TORQUE-ARM II Shaft Mount Speed Reducers

BEARING L-10 LIFE AS A FUNCTION OF SERVICE FACTOR - AGMA STANDARD 6009-A00

DODGE TORQUE-ARM II Reducers are designed to provide a minimum L-10 bearing life of 5,000 hours for the most severe operating conditions. Since the probability of all maximum load conditions occurring in an application is remote, the actual L-10 life of an application is much greater.

Remember, the L-50 average life would be approximately 25,000 hours.

The graph illustrates how bearing life varies with different service factors. For example, a DODGE TORQUE-ARM II TA3203H Reducer with a 2.0 service factor has over **50,000** hours L-10 life.

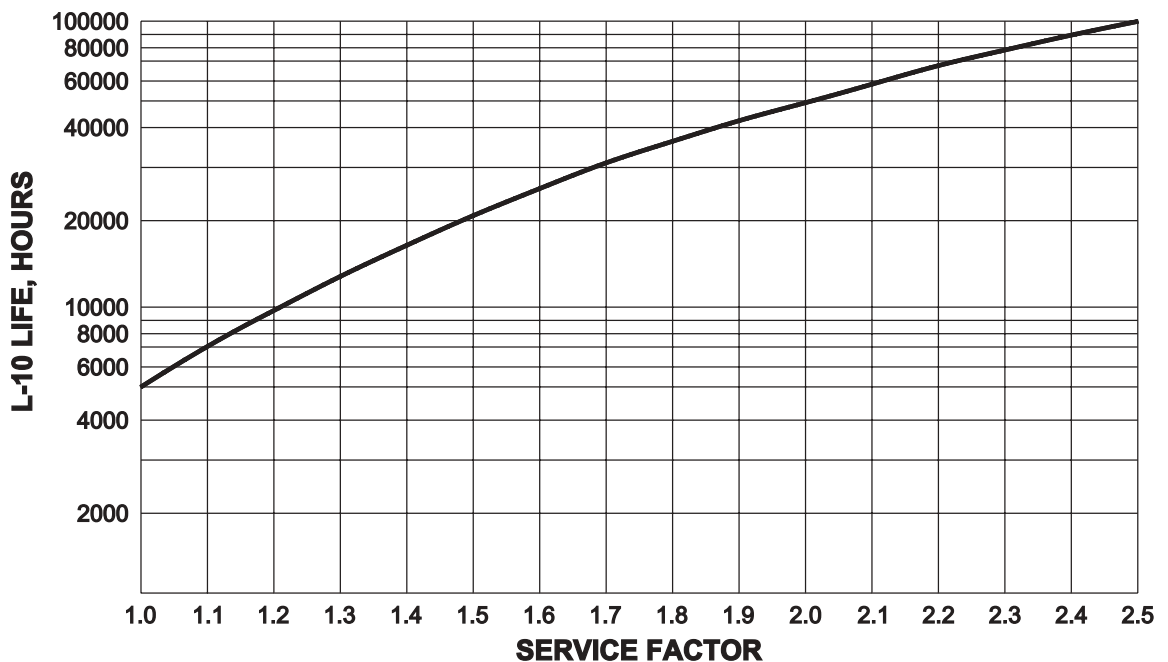

1.0 Service Factor = 5,000 hours L-10 bearing life, 25,000 L-50 hours

1.4 Service Factor = 15,300 hours L-10 bearing life, 76,500 L-50 hours

2.0 Service Factor = 50,300 hours L-10 bearing life, 251,500 L-50 hours

NOTE: Average bearing life (L-50) is typically 5 times L-10 bearing life.



TORQUE-ARM Shaft Mount Speed Reducers

Features/Benefits	G2-3
Specifications	G2-10
Nomenclature	G2-11
Easy Selection	
TORQUE-ARM - TXT	G2-13
Screw Conveyor - SCXT	G2-84
HYDROIL - HXT	G2-128
Selection	
TORQUE-ARM Selection - TXT for Electric Motors	G2-13
SCXT - Screw Conveyor Selection	G2-81
TORQUE-ARM Selection - HXT for Hydraulic Motors	G2-126
Selection/Dimensions	G2-28
TORQUE-ARM Shaft Mount Reducers - TXT	G2-28
Screw Conveyor Reducers - SCXT	G2-90
HYDROIL Shaft Mount Reducers -HXT	G2-144
Modification/Accessories	G2-70
TXT	G2-70
SCXT	G2-120
Related Products	G2-152
Renewal Parts	G2-194
Engineering/Technical	G2-197
Part Number Index	INDEX-1
Keyword Index	INDEX-27

NOTES





TORQUE-ARM Shaft Mount Speed Reducers

DODGE TORQUE-ARM TWIN TAPERED BUSHINGS MAKE DODGE TORQUE-ARM THE LEADER

DODGE Twin Tapered Bushings have provided customers over fifteen years of reliable and proven service. This exclusive feature revolutionized the shaft mount reducer concept and insured that TORQUE-ARM Speed Reducers would not seize to the customer's driven shaft. Another first from DODGE, the supplier of industry preferred quality speed reducers.

TORQUE-ARM Speed Reducers provide positive, easy-on, easy-off mounting for all reducer sizes from fractional to 700 HP. A

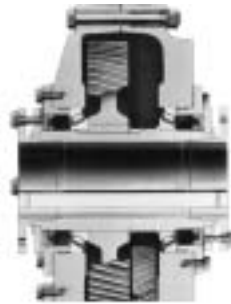

tapered bore in both sides of the reducer's output hub snugs up against a matching taper on the outer surface of the bushing . . . Twin Tapered.

Bushing mounting screws pass through the bushing flange into a mounting collar on the hub. As the screws are tightened, the bushing moves inward, gripping the driven machine's input shaft tightly and evenly around every point on its circumference.

Balanced design adds up to quality and long life

You can now realize significant cost savings with the new TXT TORQUE-ARM Speed Reducer. And here is how:

- TXT reducers now have increased horsepower ratings which may allow you to use a smaller TORQUE-ARM reducer, while receiving the same torque at the output shaft.
- The reducer mounts directly on the driven shaft, eliminating the need for a coupling or chain drive, sliding motor base, and support structure. There's no alignment problem.
- **TXT reducers incorporate standard DODGE features**
 - Ratios up to 210:1.
 - Capacities fractional to 700 HP
 - Output speeds through 400 rpm.
 - Trouble-free maintenance.
 - Up-front installation savings.
 - Quality proven design.
 - Easier, more accurate drive alignment.
- **Rugged, cast-iron housing.** Cast, corrosion-resistant gray and ductile iron housings are precision machined for positive gear alignment. Rugged housing construction provides strong, rigid support for bearings and gearing. Additionally, internal rib design helps channel oil to all bearings for superior lubrication.
- **Efficient helical gear tooth design** produces an efficiency rating of 98.5% per gear set. Gear teeth feature a softer core to resist shock loads, combined with a case carburized surface for maximum wear resistance. Precision crown shaving produces an ellipsoid tooth shape, so that teeth mesh at the stronger center area eliminating end loading. The result: uniform load distribution with no tooth-end wear.
- **Lip seals.** Metallic lip seals keep lubricating oil in, lock dirt and contaminants out. The cavity between the inner and outer lips is filled with grease at assembly to pre-lubricate the seal. A garter spring exerts a constant, gentle pressure at every point around the circumference of the shaft to insure a positive seal. All seals ride on precision ground surfaces for maximum life.
- **Dependable performance.** All DODGE TORQUE-ARM speed reducers are 100% factory noise and leak tested to assure long life and trouble-free service.
- **DODGE has a TORQUE-ARM reducer for every application.**

And all this adds up to more savings for you! The TXT reducer-the best package available to meet tough industrial requirements.

It's easy to see why DODGE TORQUE-ARM is America's #1 Shaft Mounted Speed Reducer.

FEATURES/BENEFITS



TORQUE-ARM Shaft Mount Speed Reducers

DODGE TORQUE-ARM THE COMPLETE SHAFT MOUNT SPEED REDUCER SYSTEM



DODGE TORQUE-ARM IS AMERICA'S LEADING SHAFT-MOUNT REDUCER BECAUSE:

- Experience-over 1,500,000 sold.
- Delivery-nearly 5,000 reducers and 20,000 accessories in stock.
- Quality-warranties of less than 1/2% of sales.
- Customer Preferred-over 50 years of proven experience.
- Twin Tapered Bushings-reliable installation and removal.
- Performance Capability-applications through 700 HP.
- Product Configurations-TORQUE-ARM, Screw Conveyor and HYDROIL.
- Accessory Package-motor mount, backstop, bushings and auxiliary seals.

DODGE has been the leader as a shaft mounted reducer manufacturer for over 50 years. Since our start in 1949, we have developed thousands of satisfied customers. The TORQUE-ARM success is due to initial design and rating conservatism and a rigid quality control program. We have recently tabulated the quantity of reducers sold. This has resulted in the kind of quality and dependability that's proven by one of the lowest percentage replacement rates in the industry-and that's with more than **1.5 million** units sold. Design features built into every shaft mounted TORQUE-ARM reducer are presented in this bulletin. Remember, a speed reducer is a complete system of balanced, high quality components.

1. **PRECISION HIGH QUALITY GEARING**
 - Computer Designed Helical Gears
 - 98.5% Efficiency Per Gear Stage
 - Case Carburized for Long Life
 - Strong Alloy Materials for High Load Capacity
 - Crown Shaved Gear Tooth Profile for Even Load Distribution
 - Smooth Quiet Operation with Several Teeth in Mesh
 - Designed in Conformance with AGMA

2. **MAXIMUM CAPACITY HOUSING DESIGN**
 - Rugged Cast Iron and Ductile Iron
 - Rigid Bearing Support and Positive Gear Alignment
 - High Corrosion Resistance
 - Excellent Vibration Dampening & Shock Resistance Features

3. **RELIABLE ANTI-FRICTION BEARINGS**
 - Anti-friction Bearing Manufacturers Association Bearing Ratings
 - Combination Ball & Tapered Roller Designs
 - Straddle Mounted Gears for Optimum Support
 - High Thrust Capacity Screw Conveyor Drive Bearings

4. **STRONG SHAFTS FOR SUPPORT**
 - Precision-Machined & Hardened for Maximum Load
 - High Alloy Steel for Maximum Torsional Loads
 - Generous Size Shaft Keys for Shock Loading
 - Press or Heat-Shrunk Design for Total Reliability

5. **PROVEN SEALS KEEP OIL IN AND CONTAMINANTS OUT**
 - Lip Spring-Loaded Construction
 - Metal Reinforcement for Strength
 - Broad Operating Range of -20°F to 225°F
 - 100% Factory-Tested Before Shipment
 - Smooth Ground Shaft Surfaces for Maximum Life
 - Seal Kits Available for All Reducer Sizes

6. **EFFICIENT SPLASH LUBRICATION SYSTEM**
 - Generous Oil Sump for Lubricating All Gears & Bearings
 - Standard Gear Petroleum Lubricants Are Suitable
 - Multiple Oil Plugs for Total Mounting Flexibility
 - New Breather With Baffle And Filter
 - Magnetic Drain Plug for Protection







Our success as a manufacturer begins with our design features and extends to our rigid quality program which provides the highest quality and dependability that customers have grown to expect from DODGE. The TORQUE-ARM shaft mounted reducer line, consisting of many sizes and types and with capacities from fractional through 700 HP, is available from our factory warehouse stock, branch warehouse stocks, and authorized distributors located throughout the United States. No other manufacturer in the world can claim this type of coverage and back-up assistance for their products and customer.

FEATURES/BENEFITS



TORQUE-ARM Shaft Mount Speed Reducers

DODGE TORQU-ARM ACCESSORIES

<p>TAPERED BUSHING ASSEMBLIES</p> 	<p>Securely mounts Taper Bushed Reducer to driven shaft</p> <table border="0"> <thead> <tr> <th data-bbox="628 321 701 343">Features</th> <th data-bbox="991 321 1064 343">Benefits</th> </tr> </thead> <tbody> <tr> <td data-bbox="526 361 732 526"> <ul style="list-style-type: none"> • Twin Bushings • Full Length Shaft Key • Flanged Bushing Mount • Removal Screws • Fully Split Bushings • Ductile Iron • No Setscrews • Clamp Fit </td> <td data-bbox="817 361 1153 526"> <ul style="list-style-type: none"> • Reliably supports both sides of reducer. • Maximum torque & shock load capability. • Fast & simple installation. • Reliable demount of reducer. • Eliminates fretting & seizing problems. • Strong, shock resistant bushings. • Eliminates driven shaft damage. • Reduces wobble & fits undersized shafts. </td> </tr> </tbody> </table>	Features	Benefits	<ul style="list-style-type: none"> • Twin Bushings • Full Length Shaft Key • Flanged Bushing Mount • Removal Screws • Fully Split Bushings • Ductile Iron • No Setscrews • Clamp Fit 	<ul style="list-style-type: none"> • Reliably supports both sides of reducer. • Maximum torque & shock load capability. • Fast & simple installation. • Reliable demount of reducer. • Eliminates fretting & seizing problems. • Strong, shock resistant bushings. • Eliminates driven shaft damage. • Reduces wobble & fits undersized shafts.
Features	Benefits				
<ul style="list-style-type: none"> • Twin Bushings • Full Length Shaft Key • Flanged Bushing Mount • Removal Screws • Fully Split Bushings • Ductile Iron • No Setscrews • Clamp Fit 	<ul style="list-style-type: none"> • Reliably supports both sides of reducer. • Maximum torque & shock load capability. • Fast & simple installation. • Reliable demount of reducer. • Eliminates fretting & seizing problems. • Strong, shock resistant bushings. • Eliminates driven shaft damage. • Reduces wobble & fits undersized shafts. 				
<p>STRAIGHT BORE BUSHING ASSEMBLIES</p> 	<p>Accommodate less than maximum bore straight bore reducer applications</p> <table border="0"> <thead> <tr> <th data-bbox="628 581 701 604">Features</th> <th data-bbox="991 581 1064 604">Benefits</th> </tr> </thead> <tbody> <tr> <td data-bbox="526 621 732 699"> <ul style="list-style-type: none"> • Steel or Ductile Iron • Two Bushings • Mount in Reducer Bore • Original Design </td> <td data-bbox="817 621 1153 699"> <ul style="list-style-type: none"> • High load capacity. • Locking setscrews on both sides of reducer. • Suitable for shorter driven shafts. • Equivalent to most competitive reducers. </td> </tr> </tbody> </table>	Features	Benefits	<ul style="list-style-type: none"> • Steel or Ductile Iron • Two Bushings • Mount in Reducer Bore • Original Design 	<ul style="list-style-type: none"> • High load capacity. • Locking setscrews on both sides of reducer. • Suitable for shorter driven shafts. • Equivalent to most competitive reducers.
Features	Benefits				
<ul style="list-style-type: none"> • Steel or Ductile Iron • Two Bushings • Mount in Reducer Bore • Original Design 	<ul style="list-style-type: none"> • High load capacity. • Locking setscrews on both sides of reducer. • Suitable for shorter driven shafts. • Equivalent to most competitive reducers. 				
<p>MOTOR MOUNTS</p> 	<p>Provide a compact and economical method of mounting electric motors on TORQUE-ARM Reducers</p> <table border="0"> <thead> <tr> <th data-bbox="628 777 701 800">Features</th> <th data-bbox="991 777 1064 800">Benefits</th> </tr> </thead> <tbody> <tr> <td data-bbox="526 817 732 965"> <ul style="list-style-type: none"> • All-Steel Construction • Compactness • Adjustable Top Plate • Pre-Drilled • Economical • Flexible Mounting • Interchangeability </td> <td data-bbox="817 817 1153 965"> <ul style="list-style-type: none"> • Rigid motor support. • Eliminates separate motor bases. • Fast & easy belt tensioning. • Accommodates standard NEMA Motors. • Low cost & eliminates alignment problems. • Pre-drilled for belt guard attachment. • Also fits screw conveyor drives. </td> </tr> </tbody> </table>	Features	Benefits	<ul style="list-style-type: none"> • All-Steel Construction • Compactness • Adjustable Top Plate • Pre-Drilled • Economical • Flexible Mounting • Interchangeability 	<ul style="list-style-type: none"> • Rigid motor support. • Eliminates separate motor bases. • Fast & easy belt tensioning. • Accommodates standard NEMA Motors. • Low cost & eliminates alignment problems. • Pre-drilled for belt guard attachment. • Also fits screw conveyor drives.
Features	Benefits				
<ul style="list-style-type: none"> • All-Steel Construction • Compactness • Adjustable Top Plate • Pre-Drilled • Economical • Flexible Mounting • Interchangeability 	<ul style="list-style-type: none"> • Rigid motor support. • Eliminates separate motor bases. • Fast & easy belt tensioning. • Accommodates standard NEMA Motors. • Low cost & eliminates alignment problems. • Pre-drilled for belt guard attachment. • Also fits screw conveyor drives. 				
<p>AUXILIARY SEAL KITS</p> 	<p>Provide extra sealing on Taper Bushed Reducers</p> <table border="0"> <thead> <tr> <th data-bbox="628 1020 701 1043">Features</th> <th data-bbox="991 1020 1064 1043">Benefits</th> </tr> </thead> <tbody> <tr> <td data-bbox="526 1060 732 1150"> <ul style="list-style-type: none"> • Labyrinth Seals • Economical • Simple Installation • Lubrication Fittings • Air Breather </td> <td data-bbox="817 1060 1153 1150"> <ul style="list-style-type: none"> • Protection from dust, dirt, & moisture. • Low cost reducer protection. • No drilling required on Sizes TXT 6 & larger. • Can be grease purged for protection. • Filtered air breather included. </td> </tr> </tbody> </table>	Features	Benefits	<ul style="list-style-type: none"> • Labyrinth Seals • Economical • Simple Installation • Lubrication Fittings • Air Breather 	<ul style="list-style-type: none"> • Protection from dust, dirt, & moisture. • Low cost reducer protection. • No drilling required on Sizes TXT 6 & larger. • Can be grease purged for protection. • Filtered air breather included.
Features	Benefits				
<ul style="list-style-type: none"> • Labyrinth Seals • Economical • Simple Installation • Lubrication Fittings • Air Breather 	<ul style="list-style-type: none"> • Protection from dust, dirt, & moisture. • Low cost reducer protection. • No drilling required on Sizes TXT 6 & larger. • Can be grease purged for protection. • Filtered air breather included. 				
<p>BACKSTOPS</p> 	<p>Prevents reverse of shaft direction</p> <table border="0"> <thead> <tr> <th data-bbox="628 1211 701 1234">Features</th> <th data-bbox="991 1211 1064 1234">Benefits</th> </tr> </thead> <tbody> <tr> <td data-bbox="526 1251 732 1376"> <ul style="list-style-type: none"> • Quick Installation • Internally Mounted • Oil Lubricated • Long Life • Keyed to Reducer • Reversible </td> <td data-bbox="817 1251 1153 1376"> <ul style="list-style-type: none"> • Fits input shaft of all TORQUE-ARM Reducers • Sealed inside reducer for protection. • No external relubrication required. • Case hardened, shock resistant sprags. • High load capacity. • Suitable for either direction of rotation. </td> </tr> </tbody> </table>	Features	Benefits	<ul style="list-style-type: none"> • Quick Installation • Internally Mounted • Oil Lubricated • Long Life • Keyed to Reducer • Reversible 	<ul style="list-style-type: none"> • Fits input shaft of all TORQUE-ARM Reducers • Sealed inside reducer for protection. • No external relubrication required. • Case hardened, shock resistant sprags. • High load capacity. • Suitable for either direction of rotation.
Features	Benefits				
<ul style="list-style-type: none"> • Quick Installation • Internally Mounted • Oil Lubricated • Long Life • Keyed to Reducer • Reversible 	<ul style="list-style-type: none"> • Fits input shaft of all TORQUE-ARM Reducers • Sealed inside reducer for protection. • No external relubrication required. • Case hardened, shock resistant sprags. • High load capacity. • Suitable for either direction of rotation. 				
<p>TORQUE-ARM BELT GUARDS</p> 	<p>Enclose And Protect Belt Drive</p> <table border="0"> <thead> <tr> <th data-bbox="628 1428 701 1451">Features</th> <th data-bbox="991 1428 1064 1451">Benefits</th> </tr> </thead> <tbody> <tr> <td data-bbox="526 1468 799 1576"> <ul style="list-style-type: none"> • Slotted Metal Panel Construction • Yellow Paint • Mounting Hardware • Assemblies to Reducer and Motor Mount Holes • Flexibility </td> <td data-bbox="817 1468 1153 1564"> <ul style="list-style-type: none"> • Light weight, ventilated • Meets safety requirements • Quick easy assembly • No machining needed • One size fits most common sheave diameters </td> </tr> </tbody> </table>	Features	Benefits	<ul style="list-style-type: none"> • Slotted Metal Panel Construction • Yellow Paint • Mounting Hardware • Assemblies to Reducer and Motor Mount Holes • Flexibility 	<ul style="list-style-type: none"> • Light weight, ventilated • Meets safety requirements • Quick easy assembly • No machining needed • One size fits most common sheave diameters
Features	Benefits				
<ul style="list-style-type: none"> • Slotted Metal Panel Construction • Yellow Paint • Mounting Hardware • Assemblies to Reducer and Motor Mount Holes • Flexibility 	<ul style="list-style-type: none"> • Light weight, ventilated • Meets safety requirements • Quick easy assembly • No machining needed • One size fits most common sheave diameters 				



FEATURES/BENEFITS

TORQUE-ARM Shaft Mount Speed Reducers

APPLICATION FLEXIBILITY

Typical DODGE TORQUE-ARM Reducer Installations

VERTICAL SHAFT APPLICATION

DODGE TORQUE-ARM TWIN TAPERED BUSHED VERTICAL SPEED REDUCER



TDT1530T

Application: 200 HP, Class III Service on vertical shaft mixer application. This TDT 1530 Vertical Tapered Bushed Speed Reducer with shock absorbing DYNA-V Belt Drive package replaced an expensive, hard-to-replace, open gear drive system. TORQUE-ARM reducers can mount in many positions, such as vertical shaft applications simply by repositioning the breather and drain plug for lubrication purposes. Another standard feature of compact and highly efficient TORQUE-ARM reducers.

HORIZONTAL SHAFT APPLICATION

STANDARD DODGE TORQUE-ARM TWIN TAPER BUSHED SPEED REDUCER



TXT725T X 3-15/16"

Application: 40 HP drive, Class II service, on main conveyor drive. Standard Tapered Bushed TXT 725 x 3-15/16" Speed Reducer package offers long life and dependability. Other user benefits on this horizontal shaft application include compactness, off-the-shelf components, flexible motor mount arrangement, and reliable easy-on, easy-off Tapered Bushings. The lowest cost installed system for moving bulk materials.

FLANGE MOUNTED APPLICATION

DODGE TORQUE-ARM FLANGE MOUNTED VERTICAL TWIN TAPER BUSHED SPEED REDUCER



TXT625T

Application: 15 HP, Class II Service, on Vertical Agitator Shaft in cement mixing system. This rugged reducer is rigidly mounted via the flange mounting pads which are standard on all TORQUE-ARM reducers. This no-charge, flange drilling option allows the reducer to support the agitator shaft and any thrust loads imposed. Flange mounted reducers do not require TORQUE-ARM rod assemblies.

HYDRAULIC REDUCER APPLICATION

DODGE DYROIL TORQUE-ARM TWIN TAPER BUSHED SPEED REDUCER



HXT525T WITH B30 MOTOR

Application: Variable speed DODGE HYDROIL speed reducer with hydraulic power is another example of TORQUE-ARM reducer flexibility. This version powers a rugged, mobile brand of road construction equipment. Simply regulating the pressure and volume of fluid to the motor provides variable speed, variable torque, and even direction of rotation change.

FEATURES/BENEFITS



TORQUE-ARM Shaft Mount Speed Reducers

DODGE SCREW CONVEYOR DRIVES INDUSTRY WIDE APPLICATION



DODGE quality designed with the Screw Conveyor Industry in mind

The dependable DODGE Screw Conveyor Drives provide a rugged, competitively priced, application-engineered drive for standard CEMA screw conveyors. And the screw conveyor drive incorporates the proven reliability you have come to expect from the DODGE TORQUE-ARM reducer line.

Tapered roller bearings within the drive eliminate the need for an external thrust bearing. The bearings take thrust from the screw conveyor and make external thrust bearings unnecessary.

DODGE Screw Conveyor Drives are available in 5:1, 9:1, 15:1 and 25:1 ratios and the durable drives include:

- A compact design reducer with increased torque ratings.
- The CEMA standard drive shaft.
- A standard trough end mounting adapter with CEMA four-bolt mounting.
- Standard adapter for use with choice of lip, braided or waste pack seals.
- Optional adjustable packing gland adapter.

The DODGE complete, rugged, highly developed, screw conveyor drive mounts on the trough end of your screw conveyor. Tapered roller bearings in the reducer take the thrust from the screw conveyor. This eliminates the external thrust bearing commonly required. The drives may be mounted in any position on horizontal, inclined, or vertical shafts by relocating breather and drain plugs. For complete drive between trough and motor, specify the screw conveyor drive and the following accessories: trough end plate and motor mount.

Where V-belt drives or electric motors cannot be used, DODGE offers a screw conveyor drive powered by a hydraulic motor.

Note: Guards have been removed for photographic purposes

Typical Industry Applications

Food	Agriculture
Grain	Soaps
Aggregates	Lumber
Chemicals	Stone
Minerals	clay
Coal	Glass
	... and many more



FEATURES/BENEFITS

TORQUE-ARM Shaft Mount Speed Reducers

DODGE SCREW CONVEYOR DRIVES

Three alternative seals in CEMA Standard Adapter



Lip Seals.
They're pre-lubricated for protection from dust and dirt during installation and are excellent for conveying semi-solids. Metallic parts are partially coated with synthetic rubber for added protection from corrosion.



Braided Felt Seal.
For unusually dusty environments like granaries or fertilizer plants, the braided felt seal offers special protection.



Waste Packing.
(Not supplied by DODGE)
This can be inserted in a special cavity in the adapter for added protection while operating under abrasive conditions.

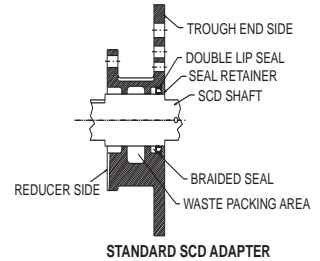

CEMA Adjustable Packing Gland Adapter

The adjustable packing gland adapter can be repacked without removing the adapter from the trough end. This packing gland adapter is mainly used in applications where there is a very abrasive environment, such as cement dust.

The packing gland allows for easy removal and installation of the braided felt seals. As the seals wear, the adjusting studs can be retightened with an open-ended wrench causing the cast iron adjusting flange to compress the seals tighter around the drive shaft and end plate.

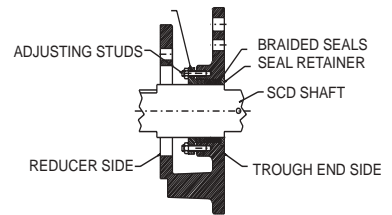

Auxiliary Seal Kit

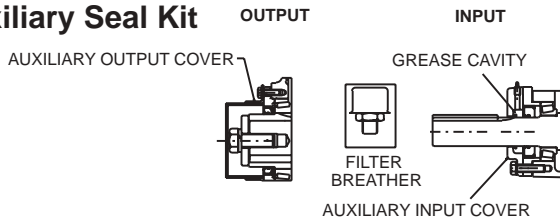

Auxiliary Seal Kits for DODGE Screw Conveyor Drives are available for SCXT Sizes 1-7 Speed Reducers. Each kit contains an input shaft auxiliary seal with cover, output shaft end cap and a filter air breather.

Belt Guard

A slotted metal panel style belt guard with mounting straps for SCXT Reducers will fit standard series motor mounts. The belt guards are designed to fit most common sheave diameters. They mount easily with no machining required.



Motor mounts need no drilling.

Rugged, all-steel DODGE motor mounts bolt directly to the screw conveyor drive reducer. They're available in fourteen sizes, which easily fit NEMA motor frames. Since the four adjusting bolts allow easy belt tensioning, it's less time-consuming and you save on installation costs immediately.



CEMA drive shafts offer easy installation and maintenance.

This means increased production, less down-time and substantial cost savings. You can save even more because of convenience and interchangeability. Different diameter drive shafts are interchangeable within each drive, and there's a wide range of diameters from 1-1/2 to 3-7/16 inches to choose from. Stainless steel and three-hole CEMA drive shafts are available on request.



FEATURES/BENEFITS



TORQUE-ARM Shaft Mount Speed Reducers

DODGE HYDROIL™ DRIVES

Hydraulically Powered TORQUE-ARM Speed Reducers with Infinitely Adjustable Speed and Torque

This is a modified version of the famous TORQUE-ARM speed reducer with the same quality features and ease of installation.

A Hydraulic motor powers the HYDROIL reducer, greatly expanding its scope of application and versatility. It has proven to be popular for locations remote from the prime mover where shafts or belt and chain drives are impractical or where electric motors are not available. Exceptional flexibility is provided in the control of the driven machine by simply regulating the pressure and volume of fluid fed to the HYDROIL motor.

Users can provide flexible control of the HYDROIL drive by selecting proper auxiliary equipment. Output speeds of the reducer are infinitely adjustable through the use of regulating valves in the hydraulic circuit. Both speed and torque can be adjusted to meet the requirements of the driven machine which can be inched or jogged. The direction of rotation is reversible.

Where V-belt drives or electric motors cannot be used, DODGE offers a screw conveyor drive powered by a hydraulic motor.

Hydroil Vane Motors-are a superior single stage vane type fluid motor. A series of internal ports admit oil to and carry it from the power element. Complete hydraulic balance of the assembly contributes to the mechanical efficiency and long life of these motors as well as to their unusually quiet operation. Other exclusive features assure a minimum of friction and efficient valving action regardless of operating speeds.



HYDROIL Vane Motors
A10 and A20



HYDROIL Vane Motor B30



HYDROIL Vane Motor B40



HYDROIL Vane Motor B50

SPECIFICATIONS



TORQUE-ARM Shaft Mount Speed Reducers

General Specifications

TORQUE-ARM II Speed Reducers:

The speed reducer shall be either a belt driven or direct coupled enclosed shaft mount type unit with a single or double reduction ratio. The reducer shall mount directly on the driven shaft and utilize an adjustable torque arm that attaches from the gear case to the support structure or foundation.

The reducer housing shall be constructed of two piece corrosion resistant, gray or ductile iron and be ribbed for added strength. All housings shall be doweled and precision machined to assure accurate alignment for all gear sets.

All gearing shall be of helical design, and crown shaved to provide an elliptoid tooth to eliminate tooth end bearing and assure meshing at the strongest tooth area. All gears shall be case carburized to insure a high surface durability with a resilient tooth core for greater impact resistance and

longer service life. Gears shall be supported between bearings to maintain proper alignment of gear meshes, to maximize load carrying capabilities, and to eliminate overhung loads imposed on bearings.

Reducer bearings shall be of the ball or tapered roller type, and provide a 25,000 hour minimum average life.

All seals shall be of the lip, spring loaded type, made of nitrile rubber.

Reducer gears and bearings shall be splash lubricated using a quality petroleum base oil, containing anti-foamants and rust inhibitors.

Reducer installation shall be accomplished by using ductile iron, fully split Twin Tapered Bushings. Reducer removal shall be accomplished by providing jack screw holes in the bushing flanges to mechanically remove the tapered assembly.

Screw Conveyor Drives:

The drive shall be either a belt driven or direct coupled enclosed, adaptor mounted unit with a single or double reduction ratio. The drive shall consist of a speed reducer, a cast iron 4 bolt mounting adaptor with a double lip and a braided felt seal, and a drive shaft machined from a high quality alloy steel. The drive shall conform to Conveyor Equipment Manufacturers Association (CEMA) standards.

The reducer housing shall be constructed of two piece corrosion resistant, gray iron. All housings shall be doweled and precision machined to assure accurate alignment of all gear sets. All gearing shall be of helical design and crown shaved to provide an elliptoid tooth form to eliminate tooth end bearing and assure meshing at the strongest tooth area. All gears shall be case carburized to insure a high

surface durability, with a resilient tooth core for greater impact resistance and longer service life. Gears shall be supported between bearings to maintain proper alignment of gear meshes, to maximize load carrying capabilities, and to eliminate overhung loads imposed on bearings.

Reducer output bearings shall be of the tapered roller type, to absorb thrust loads from the screw conveyor. All bearings shall provide 25,000 hours minimum average life.

All reducer seals shall be of the lip, spring loaded type, made of nitrile rubber.

Reducer gears and bearings shall be splash lubricated using a quality petroleum base oil containing anti-foamants and rust inhibitors.

HYDROIL Drives:

The speed reducer shall be a hydraulically powered enclosed shaft mount type unit with a single or double reduction ratio. The reducer shall mount directly on the driven shaft and utilize an adjustable torque arm that attaches from the gear case to the support structure or foundation.

The reducer shall be powered using a Hydrooil single stage vane type fluid motor. The reducer shall be provided with a cast iron SAE mounting flange adaptor and splined input shaft to allow an integral fit with the splined hydraulic motor shaft.

The reducer housing shall be constructed of two piece corrosion resistant, gray iron and be ribbed for added strength. All housings shall be doweled and precision machined to assure accurate alignment for all gear sets.

All gearing shall be of helical design, and crown shaved to provide an elliptoid tooth form to eliminate tooth end bearing and assure meshing at the strongest tooth area. All

gears shall be case carburized to insure a high surface durability with a resilient tooth core for greater impact resistance and longer service life. Gears shall be supported between bearings to maintain proper alignment of gear meshes, to maximize load carrying capabilities, and to eliminate overhung loads imposed on bearings.

Reducer bearings shall be of the ball or tapered roller type and provide a 25,000 hour minimum average life.

All seals shall be of the lip, spring loaded type, made of nitrile rubber.

Reducer gears and bearings shall be splash lubricated using a quality petroleum base oil, containing anti-foamants and rust inhibitors.

Reducer installation shall be accomplished by using ductile iron fully split Twin Tapered bushings. Reducer removal shall be accomplished by providing jack screw holes in the bushing flanges to mechanically remove the tapered assembly.

FEATURES/BENEFITS PAGE G2-3	EASY SELECTION PAGE G2-13	SELECTION/DIMENSIONS PAGE G2-28	RELATED PRODUCTS PAGE G2-152
--------------------------------	------------------------------	------------------------------------	---------------------------------



TORQUE-ARM Shaft Mount Speed Reducers

NOMENCLATURE: TORQUE-ARM REDUCERS

XXXX - X XX - x - X - XXXXX

Configuration

- TXT Standard TORQUE-ARM Reducer, 1 - 12
- TDT Large TORQUE-ARM Reducer, 13 - 15
- HXT HYDROIL TORQUE-ARM Reducer, 1 - 7

Gear Case Size

- 1 thru 12 TXT
- 13 thru 15 TDT
- 1 thru 7 HXT

Ratio *

- 5:1 Single Reduction
- 9, 15, 25:1 Double Reduction

Bushing Bore Size

- 1" - 10" TDT Twin Tapered Bushing Assembly
- 1" - 5-7/16" TAXD Straight Bore Bushing Assembly

Type of Reducer/Bushing

- T Twin Taper Bushed Reducer
- S Straight Bore Reducer

NOMENCLATURE EXAMPLE: TORQUE-ARM REDUCERS

TXT - 6 - 25 - T - x - 3-7/16"

Standard TORQUE-ARM Shaft Mount Reducer _____

Case Size 6 _____

25:1 Ratio, Double Reduction _____

Twin Taper Bushed Reducer _____

Twin Tapered Bushing Assembly with bore to fit 3-7/16" diameter driven shaft _____

TXT - 2 - 05 - S - x - 1-15/16"

Standard TORQUE-ARM Shaft Mount Reducer _____

Case Size 2 _____

5:1 Ratio, Single Reduction _____

Straight Bore Reducer _____

1-15/16" is maximum bore for TXT2 Straight Bore Reducer; no bushing required _____

HXT - 1 - 25 - T - x - 1-7/16"

HYDROIL Shaft Mount Reducer _____

Case Size 1 _____

25:1 Ratio, Double Reduction _____

Twin Taper Bushed Reducer _____

Twin Tapered Bushing Assembly with bore to kit 1-7/16" diameter driven shaft _____

* **Note: "A" or "B" in nomenclature after ratio denotes latest reducer design**

FEATURES/BENEFITS PAGE G2- 3	EASY SELECTION PAGE G2- 13	SELECTION/DIMENSIONS PAGE G2- 28	RELATED PRODUCTS PAGE G2- 152
---------------------------------	-------------------------------	-------------------------------------	----------------------------------



NOMENCLATURE

TORQUE-ARM Shaft Mount Speed Reducers

NOMENCLATURE: SCREW CONVEYOR DRIVE REDUCERS

XXXXX - X XX - x - XXXXX - XX - XXXXX

Configuration

SCXT Screw Conveyor Drive Reducer
HSCXT HYDROIL Screw Conveyor Drive Reducer

Gear Case Size

1 thru 7 SCXT
1 thru 7 HSCXT

Ratio

5:1 Single Reduction
9, 15, 25:1 Double Reduction

Motor Mount

M Standard Motor Mount for 6" - 20" screw
ML Long Motor Mount for 24" screw

Adapter Style

C Standard CEMA 4-bolt Adapter
AC Adjustable Packing Gland Adapter

CEMA Standard Drive Shaft Diameter

Sizes 1-1/2", 2", 2-7/16", 3", 3-7/16"
Dependent on screw diameter

NOMENCLATURE EXAMPLE: SCREW CONVEYOR DRIVE REDUCERS

SCXT - 7 25 - x - 3-7/16" - C - M724L

Screw Conveyor Drive Reducer

Case Size 7

25:1 Ratio, Double Reduction

Long Motor Mount for 24" screw
Standard CEMA 4-bolt Adapter
3-7/16" diameter Drive Shaft

SCXT - 5 25 - x - 2-7/16" - C - M518

Screw Conveyor Drive Reducer

Case Size 5

25:1 Ratio, Double Reduction

Standard Motor Mount for 12" screw
Standard CEMA 4-bolt Adapter
2-7/16" diameter Drive Shaft

HSCXT - 2 05 - x - 1-1/2" - AC

HYDROIL Screw Conveyor Drive Reducer

Case Size 2

5:1 Ratio, single Reduction

AC Adjustable Packing Gland Adapter
1-1/2" diameter Drive Shaft

* Note: "A" or "B" in nomenclature after ratio denotes latest reducer design



TORQUE-ARM Shaft Mount Speed Reducers EASY SELECTION METHOD (FOR ELECTRIC MOTORS)

When to Use Easy Selection

The Easy Selection tables for TXT Shaft Mount reducers are for electric motor selections up to 700 horsepower with output speeds up to 400 RPM, using AGMA recommended application class numbers. For extreme shock or high energy loads which must be absorbed, as when stalling; for power source other than an electric motor; or for extreme ambient temperatures, or oversized equipment, consult DODGE Application Engineering, (864) 288-9050.

How to Select

Step 1: Determine Class of Service-See Table 1 to determine Load Classification for applications under normal conditions. Find the type application and duty cycle that most closely matches your specific application.

Class I Steady load not exceeding Motor HP rating and light shock loads during 10 hours a day. Moderate shock loads are allowable if operation is intermittent.

For Class 1 applications, the maximum value of starting and momentary peak loads should not exceed 2 x Motor HP rating. If it exceeds this amount it should be divided by 2 and the result used in the selection table instead of the Motor HP rating.

Class II Steady load not exceeding Motor HP rating for over 10 hours a day. Moderate shock loads are allowable during 10 hours a day.

For Class II applications, the maximum value of starting and momentary peak loads should not exceed 2.8 x Motor HP rating. If it exceeds this amount it should be divided by 2.8 and the result used in the selection table instead of the Motor HP rating.

Class III Moderate shock loads for over 10 hours a day. Heavy shock loads are allowable during 10 hours a day.

For Class III applications, the maximum value of starting and momentary peak loads should not exceed 4 x Motor HP rating. If it exceeds this amount it should be divided by 4 and the result used in the selection table instead of the Motor HP rating.

Step 2: Determine Reducer Size-See the Easy Selection Tables, pages G2-16 thru G2-25. From Selection Table I, II or III read the reducer size for the application horsepower and output speed. **Note:** For applications where fan cooling is unacceptable use the Easy Selection tables with an increased Class number. Where more than one reducer selection is listed, the most economical ratio is generally listed first. See Table 31, page G2-205 for maximum input and output speeds.

Step 3: Compare Hollow Shaft Bore with the size of the driven shaft. All DODGE Torque-Arm Taper Bushed reducers require bushings. Refer to reducer pages for available bushings. If the driven shaft is larger than the bore of the selected reducer, the shaft must be machined to the proper size, or select a larger reducer. Check driven shaft and key for strength.

Step 4: Check Dimensions-See Selection/Dimensions section, pages G2-28 thru G2-69 for reducer dimensions, weights and part numbers. See Engineering/Technical section, page G2-199 for reducer mounting positions. For optional Torque-Arm rod mounting positions, see page G2-202.

FEATURES/BENEFITS PAGE G2-3	NOMENCLATURE PAGE G2-11	SELECTION/DIMENSIONS PAGE G2-28	RELATED PRODUCTS PAGE G2-151
--------------------------------	----------------------------	------------------------------------	---------------------------------

SELECTIONS



TORQUE-ARM Shaft Mount Speed Reducers

Step 5: Select a Belt Drive Arrangement-From the Sheave Ratio table, page G2-162, or the preselected 1750 RPM Motor V-drive tables, pages thru select the required sheave ratio for the belt drive. Be careful to select the belt drive so that the sheave mounted on the reducer shaft is not smaller than the minimum sheave diameter shown in Table 19, page G2-161. Note: Mount the sheave as close as possible to the reducer to minimize the effect of overhung load on the reducer.

Step 6: Select Accessories-See Modifications/Accessories section, pages G2-70 thru G2-80, for description, dimensions, weights, and part numbers for accessories available for the Torque-Arm reducer selected:

Motor Mounts Backstop Assemblies Belt Guards
Cooling Fans Auxiliary Seal Kits Filter Breathers
Mounting Brackets Output Shafts

NOTE: A Torque-Arm rod assembly is furnished with all TXT and HXT reducers, except for those factory-prepared for flange mounting. Torque-Arm reducers are shipped without oil.

Ratings and selections are the same for both taper bushed and straight bore reducers-standard, inclined or vertically mounted.

EXAMPLE: Easy Selection Method-TXT Torque-Arm Reducers

A 10 HP 1750 RPM motor is used to drive a uniformly loaded belt conveyor moving sand at 70 RPM, operating 16 hours per day. Head pulley shaft diameter is 2-7/16". Spec calls for a means of holding the conveyor from moving backwards. User needs immediately so does not have time to build his own motor mount or belt guard.

Step 1: Determine Class of Service-From Table 1, locate "belt conveyors, uniformly loaded or fed" for over 10 hours per day. This load is classified as a Class II application.

Step 2: Determine Reducer Size-From Table 3-Class II Application, page G2-22, find the column for 10 HP and read down to 70 RPM. A TXT425 reducer is the correct selection.

Step 3: Compare Hollow Shaft Bore of TXT425 with the application driven shaft diameter. Per page G2-41, 2-7/16" is the maximum bore available for this size reducer, so it will work in this application. Be sure to check driven shaft and key for strength.

Step 4: Check Dimensions and Weights-See Selection/Dimensions section, page G2-41, for reducer dimensions, weights, part numbers and other pertinent drive dimen-

sions. See Engineering/Technical section, page G2-199 for information on mounting positions.

Step 5: Select a Belt Drive Arrangement-From the Sheave Ratio table, page G2-162, or the Preselected 1750 RPM Motor V-drive table for TXT425 reducers, page G2-172, select a V-drive ratio for the conveyor speed of 70 RPM. With this information, select a belt drive that meets your customer's needs-i.e. belt style preference, service factor requirements, Taper Lock or QD mounting, etc. Sheave diameter must not be less than minimum diameters shown in Table 19, page G2-161.

Step 6: Select Accessories-See Modifications/Accessories section of catalog to pick out accessories for this application:

TXT4 Backstop Assembly - to hold conveyor from moving backwards when shutdown

TXT4 Auxiliary Seal Kit - extra help to keep sand out of the TXT425 reducer

TA4M Motor Mount - to mount motor to top of TXT425 reducer

TXT4D Belt Guard - to cover and protect the rotating belt drive

FEATURES/BENEFITS PAGE G2-3	NOMENCLATURE PAGE G2-11	SELECTION/DIMENSIONS PAGE G2-28	RELATED PRODUCTS PAGE G2-151
--------------------------------	----------------------------	------------------------------------	---------------------------------



TORQUE-ARM Shaft Mount Speed Reducers

SELECTION GUIDE: TXT TORQUE-ARM SHAFT MOUNT REDUCERS

This Is A Reference Sheet For Quick Selection And Specification Of DODGE TXT TORQUE-ARM Shaft Mount Reducers. Use It To Identify Information Needed To Make An Accurate Selection With A Step-By-Step Selection Format For Choosing Reducer, Accessories And Belt Drive

Use This Page To Make Your Own Selections Or Send This Form, With Application Data, To DODGE For Assistance. **You May Make Copies For Future Use.**

Name _____ Company Name _____
 Phone No. _____ Fax No. _____

Application Data:

Type of Driven Equipment _____
 Hours of Service per day _____ Class of Service _____
 Type of Load: Uniform _____ Moderate _____ Shock _____
 Motor Type: HP _____ RPM _____ Frame Size _____ Shaft Size _____
 RPM Of Driven Equipment _____ Driven Shaft Size _____
 Type of Reducer Mounting: Horizontal _____ Vertical: Input Up _____
 Input Down _____ Incline (Degree of) _____ Flange _____
 Unusual Ambient Temperature _____
 Other Pertinent Application Characteristics (i.e.-dusty Environment, Reversing Duty, Start/Stop Cycles, Etc.) _____

Reducer Drive Selection

Step 1 - Determine Class of Service _____
Step 2 - From Appropriate Service Class Table, Select Reducer Size And Ration That Meets Application HP and Driven RPM Requirements:
 Twin Taper Bushed _____ Straight Bore _____
Step 3 - Select Reducer Accessories Required For Application: Backstop _____
 Motor Mount: Standard _____ Long _____ Bottom _____
 Belt Guard: Standard _____ Long _____
 Cooling Fan _____ Auxiliary Seal Kit _____ Short Side _____
 Other _____

Belt Drive Specification:

Service Factor _____ Belt Drive Ratio Needed _____
 Belt Center Distance _____ Type Of Belt Desired _____
 Driver: Shaft Diameter _____ Driven: Shaft Diameter _____
 Sheave _____ Sheave _____
 Bushing _____ Bushing _____
 Belts: Size _____ Quantity _____

FEATURES/BENEFITS PAGE G2-3	NOMENCLATURE PAGE G2-11	SELECTION/DIMENSIONS PAGE G2-28	RELATED PRODUCTS PAGE G2-151
--------------------------------	----------------------------	------------------------------------	---------------------------------

SELECTION



TORQUE-ARM Shaft Mount Speed Reducers

TABLE1 - APPLICATION CLASSIFICATION AND CLASS

Application	Class Numbers	
	3 to 10 Hrs per Day	Over 10 Hrs per Day
AGITATORS (Mixers)		
Pure Liquids	I	II
Liquids and Solids	II	II
Liquids-Variable Density	II	II
BLOWERS		
Centrifugal	I	II
Lobe	II	II
Vane	II	II
BREWING AND DISTILLING		
Bottling Machinery	I	II
Brew Kettles-Continuous Duty	II	II
Cookers-Continuous Duty	II	II
Mash Tubs-Continuous Duty	II	II
Scale Hopper-Frequent Starts	II	II
CAN FILLING MACHINES	I	II
CAR DUMPERS	III	III
CAR PULLERS	II	II
CLARIFIERS	I	II
CLASSIFIERS	II	II
CLAY WORKING MACHINERY		
Brick Press	III	III
Briquette Machine	III	III
Pug Mill	II	II
COMPACTORS	★	★
COMPRESSORS		
Centrifugal	I	II
Lobe	II	II
Reciprocating, Multi-Cylinder	II	III
Reciprocating, Single-Cylinder	III	III
CONVEYORS-GENERAL PURPOSE		
Includes Apron, Assembly, belt, Bucket Chain, Flight, Oven and Screw		
Uniformly Loaded or Fed	I	II
Heavy Duty-Not Uniformly Fed	II	II
Severe Duty-Reciprocating or Shaker	III	III
CRANES	★	★
CRUSHER		
Stone or Ore	III	III
DREDGES		
Cable Reels	II	II
Conveyors	II	II
Cutter Head Drives	III	III
Pumps	III	III
Screen Drives	III	III
Stackers	II	II
Winches	II	II

★ Consult DODGE for more information on class number

Application	Class Numbers	
	3 to 10 Hrs per Day	Over 10 Hrs per Day
ELEVATORS		
Bucket	II	II
Centrifugal Discharge	I	II
Escalators	I	II
Freight	II	II
Gravity Discharge	I	II
EXTRUDERS		
General	II	II
Plastics		
Variable Speed Drive	III	III
Fixed Speed Drive	III	III
Rubber		
Continuous Screw Operation	III	III
Intermittent Screw Operation	III	III
FANS		
Centrifugal	I	II
Forced Draft	II	II
Induced Draft	II	II
Industrial & Mine	II	II
Class Numbers		
FEEDERS		
Apron	II	II
Belt	II	II
Disc	I	II
Reciprocating	III	III
Screw	II	II
FOOD INDUSTRY		
Cereal Cooker	I	II
Dough Mixer	II	II
Meat Grinders	II	II
Slicers	II	II
GENERATORS AND EXCITERS	II	II
HAMMER MILLS	III	III
HOISTS	★	★
LAUNDRY TUMBLERS	II	II
LAUNDRY WASHERS	II	III
LUMBER INDUSTRY		
Bakers		
Spindle Feed	II	II
Main Drive	III	III
Conveyors		
Burner	II	II
Main or Heavy Duty	II	II
Main Log	III	III
"Re-saw, Merry-Go-Round"	II	II
Slab	III	III
Transfer	II	II
Chains		
Floor	II	II
Green	II	III

FEATURES/BENEFITS
PAGE G2-3NOMENCLATURE
PAGE G2-11SELECTION/DIMENSIONS
PAGE G2-28RELATED PRODUCTS
PAGE G2-151



TORQUE-ARM Shaft Mount Speed Reducers

TABLE1 - APPLICATION CLASSIFICATION AND CLASS NUMBERS (continued)

Application	Class Numbers	
	3 to 10 Hrs per Day	Over 10 Hrs per Day
LUMBER INDUSTRY (continued)		
Cut-Off Saws		
Chain	II	III
Drag	II	III
Debarking Drums	III	III
Feeds		
Edger	II	II
Gang	III	III
Trimmer	II	II
Log Deck	III	III
Log Hauls-Incline-Well Type	III	III
Log Tuning Devices	III	III
Planer Feed	II	II
Planer Tilting Hoists	II	II
Rolls-Live-off brg.-Roll Cases	III	III
Sorting Table	II	II
Triple Hoist	II	II
Transfers		
Chain	II	III
Craneway	II	III
Tray Drives	II	II
Veneer Lathe Drives	II	II
METAL MILLS		
Draw bench Carriage and Main Drive	II	II
Runout Table		
Non-Reversing		
Group Drives	II	II
Individual Drives	III	III
Reversing	III	III
Slab Pushers	II	II
Shears	III	III
Wire Drawing	II	II
Wire Winding Machine	II	II
METAL STRIP PROCESSING MACHINERY		
Bridles	II	II
Coilers & Uncoliers	I	II
Edge Trimmers	II	II
Flatteners	II	II
Loopers (Accumulators)	I	I
Pinch Rolls	II	II
Scrap Choppers	II	II
Shears	III	III
Slitters	II	II
MILLS, ROTARY TYPE		
Ball & Rod		
Spur Ring Gear	III	III
Helical Ring Gear	II	II
Direct Connected	III	III
Cement Kilns	II	II
Dryers & Coolers	II	II
MIXERS, CEMENT		
	II	II

Application	Class Numbers	
	3 to 10 Hrs per Day	Over 10 Hrs per Day
PAPER MILLS		
Agitator (Mixer)	II	II
Agitator for Pure Liquors	II	II
Barking Drums	III	III
Barkers-Mechanical	III	III
Beater	II	II
Breaker Stack	II	II
Chipper	III	III
Chip Feeder	II	II
Coating Rolls	II	II
Conveyors		
Chip, Bark, Chemical	II	II
Log (including Slab)	III	III
Couch Rolls	II	II
Cutter	III	III
Cylinder Molds	II	II
Embosser	II	II
Extruder	II	II
Fourdrinier Rolls (includes Lump breaker, dandy roll, wire turning, and return rolls)	II	II
Jordan	II	II
Kiln Drive	II	II
Mt. Hope Roll	II	II
Paper Rolls	II	II
Platter	II	II
Presses-Felt & Suction	II	II
Pulper	III	III
Pumps-Vacuum	II	II
Reel (Surface Type)	II	II
Screens		
Chip	II	II
Rotary	II	II
Vibrating	III	III
Size Press	II	II
Thickener (AC Motor) (DC Motor)	II	II
Washer (AC Motor) (DC Motor)	II	II
Wind and Unwind Stand	I	I
Winders (Surface Type)	II	II
PLASTICS INDUSTRY-SECONDARY PROCESSING		
Blow Molders	II	II
Coating	II	II
Film	II	II
Pipe	II	II
Pre-Plasticizers	II	II
Rods	II	II
Sheet	II	II
Tubing	II	II

FEATURES/BENEFITS PAGE G2-3	NOMENCLATURE PAGE G2-11	SELECTION/DIMENSIONS PAGE G2-28	RELATED PRODUCTS PAGE G2-151
--------------------------------	----------------------------	------------------------------------	---------------------------------

SELECTION



TORQUE-ARM Shaft Mount Speed Reducers

TABLE1 - APPLICATION CLASSIFICATION AND CLASS NUMBERS (continued)

Application	Class Numbers	
	3 to 10 Hrs per Day	Over 10 Hrs per Day
PULLERS-BARGE HAUL	II	II
PUMPS		
Centrifugal	I	II
Proportioning	II	II
Reciprocating		
Single Acting, 3 or more cylinders	II	II
Double Acting, 2 or more cylinders	II	II
Rotary		
Gear Type	I	II
Lobe	I	II
Vane	I	II
RUBBER AND PLASTICS INDUSTRY		
Intensive Internal Mixers		
Batch Mixers	III	III
Continuous Mixers	II	II
Mixing Mill		
2 smooth rolls	II	II
or 2 corrugated rolls	III	III
Batch Drop Mill - 2 smooth rolls	II	II
Cracker Warmer - 2 roll, 1 corrugated roll	III	III
Cracker-2 corrugated rolls	III	III
Holding, Feed & Blend Mill-2 rolls	II	III
Refiner-2 rolls	II	II
Calenders	II	II
SAND MULLER	II	II
SEWAGE DISPOSAL EQUIPMENT		
Bar Screens	II	II
Chemical Feeders	II	II
Dewatering Screens	II	II
Scum Breakers	II	II
Slow or Rapid Mixers	II	II
Sludge Collectors	II	II
Thickener	II	II
Vacuum Filters	II	II

Application	Class Numbers	
	3 to 10 Hrs per Day	Over 10 Hrs per Day
SCREENS		
Air Washing	I	II
Rotary-Stone or Gravel	II	II
Traveling Water Intake	I	I
SCREW CONVEYORS		
Uniformly Loaded or Fed	I	II
Heavy Duty	II	II
SUGAR INDUSTRY		
Beet Slicer	III	III
Cane knives	II	II
Crushers	II	II
Mills (low speed end)	III	III
TEXTILE INDUSTRY		
Batchers	II	II
Calenders	II	II
Cards	II	II
Dry Cans	II	II
Dyeing Machinery	II	II
Looms	II	II
Mangles	II	II
Nappers	II	II
Pads	I	II
Stashers	II	II
Soapers	II	II
Spinners	II	II
Tenter Frames	II	II
Washers	II	II
Winders	II	II

Reference: AGMA Standard 6021-G89 (11/89). The table of application class numbers has been developed from the experience of manufacturers and users of gear drives for use in common applications and has been found to be generally satisfactory for the listed industries when gears are rated using AGMA standards. It is recommended that class numbers for special applications be agreed upon by the user and the gear manufacturer when variations of the table may be required. Special conditions can be any special type of prime mover, starting or stopping conditions, system conditions, ambient conditions, lubrication, overloads, overspeeds, brake equipped applications, high inertia and reversing loads.

EASY SELECTIONS



TORQUE-ARM Shaft Mount Speed ReducersD

TABLE 2 - CLASS I SELECTION TABEL TXT REDUCERS *

HP	Output RPM	Reducer Selection	
		Single	Double
1/4	4-70		TXT125 TXT115
	71-85		TXT115 TXT125
	86-115		TXT115 TXT109
	116-140	TXT105	TXT109 TXT115
	141-200	TXT105	TXT109
	201-400	TXT105	
1/3	5-70		TXT125 TXT115
	71-85		TXT115 TXT125
	86-115		TXT115 TXT109
	116-140	TXT105	TXT109 TXT115
	141-200	TXT105	TXT109
	201-400	TXT105	
1/2	4-6		TXT225
	7-70		TXT125 TXT115
	71-85		TXT115 TXT125
	86-115		TXT115 TXT109
	116-140	TXT105	TXT109 TXT115
	141-200	TXT105	TXT109
	201-400	TXT105	
3/4	4-5		TXT325A
	6-10		TXT225
	11-70		TXT125 TXT115
	71-85		TXT115 TXT125
	86-115		TXT115 TXT109
	116-140	TXT105	TXT109 TXT115
	141-200	TXT105	TXT109
	201-400	TXT105	
1	4-5		TXT425A
	6-7		TXT325A
	8-15		TXT225
	16-70		TXT125 TXT115
	71-85		TXT115 TXT125
	86-115		TXT115 TXT109
	116-140	TXT105	TXT109 TXT115
	141-200	TXT105	TXT109
	201-400	TXT105	
1-1/2	4		TXT525B
	5-7		TXT425A
	8-12		TXT325A
	13-23		TXT225
	24-70		TXT125 TXT115
	71-85		TXT115 TXT125
	86-115		TXT115 TXT109
	116-140	TXT105	TXT109 TXT115
	141-200	TXT105	TXT109
	201-400	TXT105	

* See page G2-199 for lubrication for 15 RPM and slower

HP	Output RPM	Reducer Selection	
		Single	Double
2	4-6		TXT525B
	7-10		TXT425A
	11-17		TXT325A
	18-32		TXT225 TXT215
	33-70		TXT125 TXT115
	71-85		TXT115 TXT125
	86-115		TXT115 TXT109
	116-140	TXT105	TXT109 TXT115
	141-200	TXT105	TXT109
201-400	TXT105		
3	4-5		TXT625
	6-10		TXT525B
	11-15		TXT425A
	16-26		TXT325A
	27-51		TXT225 TXT215
	52-70		TXT125 TXT115
	71-85		TXT115 TXT125
	86-115		TXT115 TXT109
	116-140	TXT105	TXT109 TXT115
	141-200	TXT105	TXT109
201-400	TXT105		
5	5-6		TXT725
	7-9		TXT625
	10-17		TXT525B
	18-26		TXT425A TXT415A
	27-46		TXT325A TXT315A
	47-70		TXT225 TXT215
	71-85		TXT215 TXT225
	86-92		TXT109 TXT215
	93-115		TXT115 TXT109
	116-119		TXT109 TXT115
	120-140	TXT105	TXT109 TXT115
	141-200	TXT105	TXT109
	201-400	TXT105	
7-1/2	4-6		TXT825
	7-9		TXT725
	10-15		TXT625
	16-26		TXT525B
	27-40		TXT425A TXT415A
	41-70		TXT325A TXT315A
	71-74		TXT315A TXT325A
	75-85		TXT215 TXT225
	86-95		TXT215 TXT209
	96-140	TXT205	TXT209 TXT215
	141-200	TXT205	TXT209
	201-231	TXT205	
	232-400	TXT105	

FEATURES/BENEFITS PAGE G2-3	NOMENCLATURE PAGE G2-11	SELECTION/DIMENSIONS PAGE G2-28	RELATED PRODUCTS PAGE G2-151
--------------------------------	----------------------------	------------------------------------	---------------------------------

EASY SELECTIONS



TORQUE-ARM Shaft Mount Speed Reducers

TABLE 2 - CLASS I SELECTION TABLE TXT REDUCERS (Cont'd)*

HP	Output RPM	Reducer Selection		
		Single	Double	
10	5		TXT926	
	6-8		TXT825	
	9-12		TXT725	
	13-20		TXT625	
	21-36		TXT525B TXT515B	
	37-56		TXT425A TXT415A	
	57-70		TXT325A TXT315A	
	71-85		TXT315A TXT325A	
	86-103		TXT315A TXT309A	
	104-115		TXT215 TXT209	
	116-140	TXT305A	TXT215	
	141-158	TXT305A	TXT309A	
	159-200	TXT305A	TXT309A	
201-400	TXT205			
15	5-6		TXT1024	
	7-8		TXT926	
	9-13		TXT825	
	14-19		TXT725	
	20-32		TXT625 TXT615	
	33-56		TXT525B TXT515B	
	57-70		TXT425A TXT415A	
	71-85		TXT415A TXT425A	
	86-93		TXT415A TXT409A	
	94-115		TXT309A+ TXT315A	
	116-140	TXT405A	TXT315A	TXT309A+
	141-145	TXT405A	TXT309A+	
	146-200	TXT305A	TXT309A+	
	201-400	TXT305A		
	20	4-6		TXT1225
7-8			TXT1024	
9-12			TXT926	
13-18			TXT825	
19-26			TXT725 TXT715	
27-45			TXT625 TXT615	
46-70			TXT525B TXT515B	
71-78			TXT515B TXT525B	
79-85			TXT415A TXT425A	
86-115			TXT415A TXT409A+	
116-140		TXT405A	TXT409A+	TXT415A+
141-200		TXT405A	TXT309A+	
201-241		TXT405A		
242-400		TXT305A+		
25		5-7		TXT1225
	8-10		TXT1024	
	11-15		TXT926	
	16-23		TXT825	

* See page G2-199 for lubrication for 15 RPM and slower

HP	Output RPM	Reducer Selection		
		Single	Double	
25	24-33		TXT725 TXT715	
	34-59		TXT625 TXT615	
	60-70		TXT525B+ TXT515B+	
	71-80		TXT515B+ TXT525B+	
	81-101		TXT515B+ TXT509B+	
	102-132	TXT505A	TXT415A+	TXT409A+
	133-140	TXT505A	TXT409A+	TXT415A+
	141-163	TXT505A	TXT409A+	
	164-200	TXT405A+	TXT409A+	
	201-400	TXT405A+		
	30	4-5		TDT1425
		6-9		TXT1225
		10-13		TXT1024
14-19			TXT926	
20-28			TXT825 TXT815	
29-41			TXT725 TXT715	
42-70			TXT625 TXT615	
71-75			TXT615 TXT625	
76-115			TXT515B+ TXT509B+	
116-125		TXT605	TXT509B+	TXT515B+
126-131		TXT605	TXT409A+	
132-200		TXT505A	TXT409A+	
201-215		TXT505A+		
216-400	TXT405A+			
40	5-6		TDT1425	
	7		TDT1325	
	8-12		TXT1225	
	13-18		TXT1024	
	19-25		TXT926 TXT915	
	26-38		TXT825 TXT815	
	39-57		TXT725 TXT715	
	58-70		TXT625 TXT615	
	71-81		TXT615+ TXT625+	
	82-114	TXT605	TXT615+ TXT609+	
	115-125	TXT605	TXT515B+ TXT509B+	
	126-200	TXT605	TXT509B+	
	201-241	TXT605		
242-400	TXT505A+			
50	3-5		TDT1530	
	6-8		TDT1425	
	9		TDT1325	
	10-15		TXT1225	
	16-22		TXT1024	
	23-32		TXT926 TXT915	
	33-49		TXT825 TXT815	
	50-70		TXT725 TXT715	

+ Fan cooling required - see page G2-80

FEATURES/BENEFITS
PAGE G2-3

NOMENCLATURE
PAGE G2-11

SELECTION/DIMENSIONS
PAGE G2-28

RELATED PRODUCTS
PAGE G2-151



TORQUE-ARM Shaft Mount Speed Reducers

TABLE 2 - CLASS I SELECTION TABEL TXT REDUCERS (Cont'd) ★

HP	Output RPM	Reducer Selection	
		Single	Double
50	71-74		TXT715 TXT725
	75-125		TXT615+ TXT709+
	126-163	TXT605+	TXT709+
	164-200	TXT605+	TXT609+
	201-400	TXT605+	
60	4-6		TDT1530
	7-11		TDT1425
	12		TDT1325
	13-18		TXT1225
	19-27		TXT1024 TXT1015
	28-39		TXT926 TXT915
	40-60		TXT825 TXT815
	61-70		TXT725+ TXT715+
	71-120		TXT715+ TXT709+
	121-131	TXT705	TXT709+
	132-200	TXT605+	TXT709+
	201-400	TXT605+	
75	5-8		TDT1530
	9-13		TDT1425
	14-15		TDT1325
	16-23		TXT1225
	24-34		TXT1024 TXT1015
	35-50		TXT926 TXT915
	51-70		TXT825 TXT815
	71-78		TXT815+
	79-120		TXT715+ TXT709+
	121-200	TXT705	TXT709+
	201-210	TXT705	
	211-400	TXT605+	
	100	6-11	
12-17			TDT1425
18-22			TDT1325
23-31			TXT1225 TXT1215
32-46			TXT1024 TXT1015
47-69			TXT926+ TXT915+
70-120			TXT815+
121-123		TXT805+	TXT709+
124-200		TXT705+	TXT709+
201-400		TXT705+	
125		8-14	
	15-22		TDT1425
	23-29		TDT1325
	30-40		TXT1225 TXT1215
	41-59		TXT1024 TXT1015
	60-70		TXT915+ TXT926+
	71-90		TXT915+
	91-123		TXT815+
	124-172	TXT805+	
	173-400	TXT705+	

★ See page G2-199 for lubrication for 15 RPM and slower

HP	Output RPM	Reducer Selection	
		Single	Double
150	9-17		TDT1530
	18-27		TDT1425
	28-36		TDT1325
	37-49		TXT1225 TXT1215
	50-70		TXT1024 TXT1015
	71-75		TXT1015+ TXT1024+
	76-80		TXT1015+
	81-120		TXT915
	121-165	TXT905	
166-400	TXT805+		
200	12-23		TDT1530
	24-36		TDT1425
	37-51		TDT1325+
	52-68		TXT1225: TXT1215*
	69-120		TXT1015+
	212-400	TXT905+	
250	16-30		TDT1530
	31-46		TDT1425+
	47-67		TDT1325+
	68-75		TXT1225* TXT1215*
	76-120		TXT1215:
300	19-36		TDT1530
	37-58		TDT1425*
	59-70		TDT1325+
	71-75		TDT1325*
	83-120		TXT1215*
350	23-43		TDT1530+
	44-69		TDT1425*
	70-75		TDT1325*
400	27-50		TDT1530+
	51-75		TDT1425*
450	30-31		TDT1530*
	32-57		TDT1530+
	59-75		TDT1425*
500	34-57		TDT1530*
	66-75		TDT1425*
600	41-57		TDT1530*
700	50-57		TDT1530*

+ Fan cooling required - see page G2-80.

* Heat exchanger required - see page G2-80.

FEATURES/BENEFITS PAGE G2-3	NOMENCLATURE PAGE G2-11	SELECTION/DIMENSIONS PAGE G2-28	RELATED PRODUCTS PAGE G2-151
--------------------------------	----------------------------	------------------------------------	---------------------------------

EASY SELECTIONS



TORQUE-ARM Shaft Mount Speed Reducers

TABLE 3 - CLASS II SELECTION TABEL TXT REDUCERS *

HP	Output RPM	Reducer Selection	
		Single	Double
1/4	5-70		TXT125 TXT115
	71-85		TXT115 TXT125
	86-115		TXT115 TXT109
	116-140	TXT105	TXT109 TXT115
	141-200	TXT105	TXT109
	201-400	TXT105	
1/3	4-6		TXT225
	7-70		TXT125 TXT115
	71-85		TXT115 TXT125
	86-115		TXT115 TXT109
	116-140	TXT105	TXT109 TXT115
	141-200	TXT105	TXT109
1/2	201-400	TXT105	
	4-5		TXT325A
	6-9		TXT225
	10-70		TXT125 TXT115
	71-85		TXT115 TXT125
	86-115		TXT115 TXT109
	116-140	TXT105	TXT109 TXT115
	141-200	TXT105	TXT109
3/4	201-400	TXT105	
	4-5		TXT425A
	6-8		TXT325A
	9-16		TXT225
	17-70		TXT125 TXT115
	71-85		TXT115 TXT125
	86-115		TXT115 TXT109
	116-140	TXT105	TXT109 TXT115
	141-200	TXT105	TXT109
	201-400	TXT105	
1	5-7		TXT425A
	8-11		TXT325A
	12-22		TXT225
	23-70		TXT125 TXT115
	71-85		TXT115 TXT125
	86-115		TXT115 TXT109
	116-140	TXT105	TXT109 TXT115
	141-200	TXT105	TXT109
	201-400	TXT105	
	1-1/2	5-6	
7-11			TXT425A
12-18			TXT325A
19-34			TXT225 TXT215
35-70			TXT125 TXT115
71-85			TXT115 TXT125
86-115			TXT115 TXT109

* See page G2-199 for lubrication for 15 RPM and slower

HP	Output RPM	Reducer Selection	
		Single	Double
1-1/2	116-140	TXT105	TXT109 TXT115
	141-200	TXT105	TXT109
	201-400	TXT105	
2	4-5		TXT625
	6-9		TXT525B
	10-14		TXT425A
	15-24		TXT325A TXT315A
	25-47		TXT225 TXT215
	48-70		TXT125 TXT115
	71-85		TXT115 TXT125
	86-115		TXT115 TXT109
	116-140	TXT105	TXT109 TXT115
	141-200	TXT105	TXT109
3	201-400	TXT105	
	4-5		TXT725
	6-8		TXT625
	9-14		TXT525B
	15-22		TXT425A TXT415A
	23-38		TXT325A TXT315A
	39-70		TXT225 TXT215
	71-75		TXT215 TXT225
	76-85		TXT115 TXT125
	86-115		TXT115 TXT109
	116-140	TXT105	TXT109 TXT115
	141-200	TXT105	TXT109
	201-400	TXT105	
	5	4-6	
7-8			TXT725
9-14			TXT625
15-24			TXT525B
25-37			TXT425A TXT415A
38-69			TXT325A TXT315A
70-85			TXT215 TXT225
86-89			TXT215 TXT209
90-136		TXT205	TXT209 TXT215
137-140		TXT205	TXT115 TXT209
141-191		TXT205	TXT109
192-200		TXT105	TXT109
201-400		TXT105	
7-1/2	5		TXT926
	6-9		TXT825
	10-13		TXT725
	14-21		TXT625
	22-38		TXT525B TXT515B
	39-59		TXT425A TXT415A
	60-70		TXT325A TXT315A
	71-85		TXT315A TXT325A

+ Fan cooling required - see page G2-80.

FEATURES/BENEFITS PAGE G2-3	NOMENCLATURE PAGE G2-11	SELECTION/DIMENSIONS PAGE G2-28	RELATED PRODUCTS PAGE G2-151
--------------------------------	----------------------------	------------------------------------	---------------------------------



TORQUE-ARM Shaft Mount Speed Reducers

TABLE 3 - CLASS II SELECTION TABEL TXT REDUCERS(Cont'd) ★

HP	Output RPM	Reducer Selection	
		Single	Double
7-1/2	86-110		TXT315A TXT309A
	111-122		TXT215
	123-140	TXT305A	TXT209 TXT215
	141-183	TXT305A	TXT209
	184-200	TXT205	TXT209
	201-400	TXT205	
10	4		TXT1225
	5		TXT1024
	6-7		TXT926
	8-12		TXT825
	13-18		TXT725
	19-29		TXT625 TXT615
	30-52		TXT525B TXT515B
	53-70		TXT425A TXT415A
	71-84		TXT415A TXT425A
	85-130		TXT315A TXT309A
	131-140	TXT305A	TXT315A TXT309A
	141-200	TXT305A	TXT309A
	201-353	TXT305A	
	354-400	TXT205	
	15	4-6	
7-9			TXT1024
10-12			TXT926
13-19			TXT825
20-27			TXT725
28-47			TXT625 TXT615
48-70			TXT525B TXT515B
71-82			TXT515B TXT525B
83-117			TXT415A TXT409A
118-140		TXT405A	TXT409A TXT415A
141-150		TXT405A	TXT409A
151-200		TXT405A	TXT309A+
201-269		TXT405A	
270-400		TXT305A	
20		5	
	6-8		TXT1225
	9-12		TXT1024
	13-17		TXT926
	18-26		TXT825
	27-38		TXT725 TXT715
	39-68		TXT625 TXT615
	69-80		TXT515B TXT525B
	81-89		TXT515B
	90-117		TXT515B+ TXT509B+
	118-125	TXT505A	TXT409A+ TXT415A+
	126-200	TXT505A	TXT409A+
	201-400	TXT405A+	

★ See page G2-199 for lubrication for 15 RPM and slower

HP	Output RPM	Reducer Selection	
		Single	Double
25	4-6		TDT1425
	7-10		TXT1225
	11-15		TXT1024
	16-22		TXT926
	23-33		TXT825 TXT815
	34-49		TXT725 TXT715
	50-80		TXT615 TXT625
	81-94		TXT615 TXT609
	95-125	TXT605	TXT509B+ TXT515B+
	126-174	TXT605	TXT509B+
	175-200	TXT505A	TXT409A+
	201-270	TXT505A	
	271-400	TXT405A+	
30	5-7		TDT1425
	8		TDT1325
	9-12		TXT1225
	13-19		TXT1024
	20-27		TXT926 TXT915
	28-41		TXT825 TXT815
	42-60		TXT725 TXT715
	61-76		TXT625 TXT615
	77-89		TXT615 TXT609
	90-125	TXT605	TXT615+ TXT609+
	126-200	TXT605	TXT509B+
	201-233	TXT605	
	234-349	TXT505A+	
350-400	TXT405A+		
40	4-6		TDT1530
	7-9		TDT1425
	10-11		TDT1325
	12-17		TXT1225
	18-25		TXT1024
	26-36		TXT926 TXT915
	37-56		TXT825 TXT815
	57-75		TXT725 TXT715
	76-88		TXT715
	89-114		TXT615+ TXT609+
	115-120		TXT615+ TXT609+
	121-200	TXT605	TXT609+
	201-347	TXT605+	
348-400	TXT505A+		
50	5-8		TDT1530
	9-12		TDT1425
	13-14		TDT1325
	15-21		TXT1225
	22-32		TXT1024 TXT1015
	33-46		TXT926 TXT915

+ Fan cooling required - see page G2-80.

FEATURES/BENEFITS PAGE G2-3	NOMENCLATURE PAGE G2-11	SELECTION/DIMENSIONS PAGE G2-28	RELATED PRODUCTS PAGE G2-151
--------------------------------	----------------------------	------------------------------------	---------------------------------

EASY SELECTIONS



TORQUE-ARM Shaft Mount Speed Reducers

TABLE 3 - CLASS II SELECTION TABEL TXT REDUCERS (Cont'd)*

HP	Output RPM	Reducer Selection		
		Single	Double	
50	47-70		TXT825 TXT815	
	71-72		TXT815 TXT825	
	73-95		TXT715+	
	96-110	TXT705	TXT709 TXT715+	
	111-120	TXT705	TXT709+ TXT715+	
	121-179	TXT705	TXT709+	
	180-200	TXT605+	TXT609+	
	201-400	TXT605+		
60	5-9		TDT1530	
	10-14		TDT1425	
	15-18		TDT1325	
	19-26		TXT1225	
	27-39		TXT1024 TXT1015	
	40-56		TXT926 TXT915	
	57-70		TXT825 TXT815	
	71-75		TXT815 TXT825	
	76-89		TXT815	
	90-120	TXT705	TXT715+ TXT709+	
	121-200	TXT705	TXT709+	
	201-285	TXT705		
	286-400	TXT605+		
	75	7-12		TDT1530
13-18			TDT1425	
19-24			TDT1325	
25-33			TXT1225 TXT1215	
34-49			TXT1024 TXT1015	
50-73			TXT926 TXT915	
74-75			TXT815 TXT825	
76-120		TXT805	TXT815+	
121-133		TXT805	TXT709+	
134-200		TXT705	TXT709+	
201-400		TXT705		
100		8-16		TDT1530
		17-25		TDT1425
		26-33		TDT1325
	34-45		TXT1225 TXT1215	
	46-67		TXT1024 TXT1015	
	68-75		TXT915+ TXT926+	
	76-103		TXT915+	
	104-120	TXT905	TXT815+	
	121-149	TXT905		
	150-180	TXT805		
	181-200	TXT805	TXT709	
	201-204	TXT805		
	205-246	TXT705		
	247-400	TXT705+		

* See page G2-199 for lubrication for 15 RPM and slower

HP	Output RPM	Reducer Selection		
		Single	Double	
125	11-20		TDT1530	
	21-31		TDT1425	
	32-43		TDT1325	
	44-58		TXT1225 TXT1215	
	59-75		TXT1024 TXT1015	
	76-85		TXT1015	
	86-120		TXT915+	
	145-209	TXT905		
	210-303	TXT805+		
	304-400	TXT705+		
150	13-25		TDT1530	
	26-38		TDT1425	
	39-54		TDT1325	
	55-72		TXT1225+ TXT1215+	
	73-75		TXT1015+ TXT1024+	
	76-120		TXT1015+	
	184-279	TXT905+		
	280-400	TXT805+		
	200	18-33		TDT1530
		34-53		TDT1425+
54-75			TDT1325+	
77-120			TXT1215:	
250	23-42		TDT1530	
	43-46		TDT1425+	
	47-69		TDT1425:	
	70-75		TDT1325+	
300	28-53		TDT1530	
	54-75		TDT1425:	
350	33-57		TDT1530	
	66-75		TDT1425:	
400	38-57		TDT1530+	
450	43-57		TDT1530+	
500	50-57		TDT1530+	

+ Fan cooling required - see page G2-80.

* Heat exchanger required - see page G2-80.



TORQUE-ARM Shaft Mount Speed Reducers

TABLE 4 - CLASS III SELECTION TABLE TXT REDUCERS ★

HP	Output RPM	Reducer Selection	
		Single	Double
1/4	4-6		TXT225
	7-70		TXT125 TXT115
	71-85		TXT115 TXT125
	86-89		TXT115 TXT109
	90-115		TXT115 TXT109
	116-140	TXT105	TXT109 TXT115
	141-200	TXT105	TXT109
	201-400	TXT105	
1/3	5-9		TXT225
	10-70		TXT125 TXT115
	71-85		TXT115 TXT125
	86-115		TXT115 TXT109
	116-140	TXT105	TXT109 TXT115
	141-200	TXT105	TXT109
	201-400	TXT105	
1/2	4-5		TXT425A
	6-7		TXT325A
	8-15		TXT225
	16-70		TXT125 TXT115
	71-85		TXT115 TXT125
	86-115		TXT115 TXT109
	116-140	TXT105	TXT109 TXT115
	141-200	TXT105	TXT109
201-400	TXT105		
3/4	4		TXT525B
	5-7		TXT425A
	8-12		TXT325A
	13-23		TXT225
	24-70		TXT125 TXT115
	71-85		TXT115 TXT125
	86-115		TXT115 TXT109
	116-140	TXT105	TXT109 TXT115
	141-200	TXT105	TXT109
	201-400	TXT105	
1	4-6		TXT525B
	7-10		TXT425A
	11-17		TXT325A
	18-32		TXT225
	33-70		TXT125 TXT115
	71-85		TXT115 TXT125
	86-115		TXT115 TXT109
	116-140	TXT105	TXT109 TXT115
	141-200	TXT105	TXT109
	201-400	TXT105	
1-1/2	4-5		TXT625
	6-10		TXT525B

★ See page G2-199 for lubrication for 15 RPM and slower

HP	Output RPM	Reducer Selection	
		Single	Double
1-1/2	11-15		TXT425A
	16-26		TXT325A
	27-51		TXT225 TXT215
	52-70		TXT125 TXT115
	71-85		TXT115 TXT125
	86-115		TXT115 TXT109
	116-140	TXT105	TXT109 TXT115
	141-200	TXT105	TXT109
	201-400	TXT105	
	2	5-7	
8-13			TXT525B
14-21			TXT425A
22-36			TXT325A TXT315A
37-71			TXT225 TXT215
72-85			TXT115 TXT125
86-115			TXT115 TXT109
116-140		TXT105	TXT109 TXT115
141-200		TXT105	TXT109
201-400		TXT105	
3	4-5		TXT825
	6-7		TXT725
	8-12		TXT625
	13-20		TXT525B
	21-32		TXT425A TXT415A
	33-57		TXT325A TXT315A
	58-70		TXT225 TXT215
	71-85		TXT215 TXT225
	86-89		TXT215 TXT209
	90-113	TXT205	TXT215 TXT209
	114-140	TXT205	TXT109 TXT115
	141-155	TXT205	TXT109
	156-200	TXT105	TXT109
201-400	TXT105		
5	5		TXT926
	6-8		TXT825
	9-12		TXT725
	13-20		TXT625
	21-36		TXT525B TXT515B
	37-56		TXT425A TXT415A
	57-70		TXT325A TXT315A
	71-85		TXT315A TXT325A
	86-103		TXT315A TXT309A
	104-114	TXT305A	TXT215 TXT309A
	115-140	TXT305A	TXT209 TXT215
	141-167	TXT305A	TXT209
	168-200	TXT205	TXT209
	201-400	TXT205	

FEATURES/BENEFITS PAGE G2-3	NOMENCLATURE PAGE G2-11	SELECTION/DIMENSIONS PAGE G2-28	RELATED PRODUCTS PAGE G2-151
--------------------------------	----------------------------	------------------------------------	---------------------------------

EASY SELECTIONS



TORQUE-ARM Shaft Mount Speed Reducers

TABLE 4 - CLASS III SELECTION TABLE TXT REDUCERS (Cont'd)*

HP	Output RPM	Reducer Selection		
		Single	Double	
7-1/2	5-6		TXT1024	
	7-8		TXT926	
	9-13		TXT825	
	14-19		TXT725	
	20-32		TXT625 TXT615	
	33-56		TXT525B TXT515B	
	57-70		TXT425A TXT415A	
	71-85		TXT415A TXT425A	
	86-93		TXT415A TXT409A	
	94-140	TXT405A	TXT309A	TXT315A
	141-144	TXT405A		TXT309A
	145-200	TXT305A		TXT309A
	201-400	TXT305A		
10	4-6		TXT1225	
	7-8		TXT1024	
	9-12		TXT926	
	13-18		TXT825	
	19-26		TXT725 TXT715	
	27-45		TXT625 TXT615	
	46-70		TXT525B TXT515B	
	71-78		TXT515B TXT525B	
	79-92		TXT415A	
	93-105		TXT415A TXT409A	
	106-141	TXT405A	TXT409A	TXT415A
	142-200	TXT405A		TXT309A
	201-241	TXT405A		
	242-400	TXT305A		
15	4-5		TDT1425	
	6-9		TXT1225	
	10-13		TXT1024	
	14-19		TXT926	
	20-28		TXT825 TXT815	
	29-41		TXT725 TXT715	
	42-70		TXT625 TXT615	
	71-75		TXT615 TXT625	
	76-93		TXT515B	
	94-115		TXT515B TXT509B	
	116-125	TXT605	TXT509B	TXT515B
	126-131	TXT605		TXT509B
	132-200	TXT505A		TXT409A
	201-215	TXT505A		
216-400	TXT405A			
20	5-6		TDT1425	
	7		TDT1325	
	8-12		TXT1225	
	13-18		TXT1024	
	19-25		TXT926 TXT915	

★ See page G2-199 for lubrication for 15 RPM and slower

HP	Output RPM	Reducer Selection		
		Single	Double	
20	26-38		TXT825 TXT815	
	39-57		TXT725 TXT715	
	58-70		TXT625 TXT615	
	71-114		TXT615 TXT609	
	115-125	TXT605	TXT509B+	TXT515B+
	126-200	TXT605		TXT509B+
	201-218	TXT605		
	219-324	TXT505A		
	325-400	TXT405A+		
	4-5			TDT1530
	6-8			TDT1425
9			TDT1325	
10-15			TXT1225	
16-22			TXT1024	
25	23-32		TXT926 TXT915	
	33-49		TXT825 TXT815	
	50-70		TXT725 TXT715	
	71-74		TXT715 TXT725	
	75-104		TXT615 TXT609	
	105-113		TXT615+ TXT609	
	114-125	TXT605	TXT615+	TXT609+
	126-200	TXT605		TXT609+
	201-294	TXT605		
	295-400	TXT505A+		
	4-6			TDT1530
7-10			TDT1425	
11-12			TDT1325	
13-18			TXT1225	
19-27			TXT1024 TXT1015	
28-39			TXT926 TXT915	
40-60			TXT825 TXT815	
61-70			TXT725 TXT715	
71-98			TXT715	
99-125			TXT615+ TXT609+	
126-131	TXT705		TXT609+	
132-200	TXT605		TXT609+	
201-381	TXT605			
382-400	TXT505A+			
40	5-9		TDT1530	
	10-14		TDT1425	
	15-17		TDT1325	
	18-25		TXT1225	
	26-37		TXT1024 TXT1015	
	38-53		TXT926 TXT915	
	54-70		TXT825 TXT815	
	71-84		TXT815	
	85-89		TXT715 TXT709	

+ Fan cooling required - see page G2-80.

FEATURES/BENEFITS PAGE G2-3	NOMENCLATURE PAGE G2-11	SELECTION/DIMENSIONS PAGE G2-28	RELATED PRODUCTS PAGE G2-151
--------------------------------	----------------------------	------------------------------------	---------------------------------



TORQUE-ARM Shaft Mount Speed Reducers

TABLE 4 - CLASS III SELECTION TABEL TXT REDUCERS (Cont'd)*

HP	Output RPM	Reducer Selection	
		Single	Double
40	90-120	TXT705	TXT715+ TXT709
	121-200	TXT705	TXT709+
	201-249	TXT705	
	250-400	TXT605+	
50	6-11		TDT1530
	12-17		TDT1425
	18-22		TDT1325
	23-31		TXT1225 TXT1215
	32-46		TXT1024 TXT1015
	47-69		TXT926 TXT915
	70-75		TXT815 TXT825
	76-110		TXT815
	111-120		TXT715+ TXT709+
	121-123	TXT805	TXT709+
	124-200	TXT705	TXT709+
	201-400	TXT705	
60	7-14		TDT1530
	15-21		TDT1425
	22-28		TDT1325
	29-38		TXT1225 TXT1215
	39-56		TXT1024 TXT1015
	57-75		TXT926 TXT915
	76-85		TXT915
	86-115		TXT815
	116-141	TXT805	
	142-161	TXT805	TXT709+
	162-200	TXT705	TXT709+
	201-400	TXT705	
	75	9-17	
18-26			TDT1425
27-36			TDT1325
37-49			TXT1225 TXT1215
50-72			TXT1024 TXT1015
73-75			TXT915+ TXT926+
76-120			TXT915+
121-165		TXT905	
166-234		TXT805	
235-400	TXT705		
100	12-23		TDT1530
	24-36		TDT1425
	37-51		TDT1325
	52-68		TXT1225+ TXT1215+
	69-120		TXT1015
	175-259	TXT905	
	260-387	TXT805+	
	388-400	TXT705+	

★ See page G2-199 for lubrication for 15 RPM and slower

HP	Output RPM	Reducer Selection	
		Single	Double
125	16-30		TDT1530
	31-43		TDT1425
	44-46		TDT1425+
	47-67		TDT1325
	68-70		TXT1225+ TXT1215+
	71-75		TXT1215+ TXT1225+
	76-90		TXT1215+
150	91-120		TXT1015+
	19-36		TDT1530
	37-41		TDT1425
	42-58		TDT1425+
	59-75		TDT1325+
	83-110		TXT1215*
200	27-50		TDT1530
	51-75		TDT1425*
250	34-57		TDT1530
	66-75		TDT1425*
300	41-57		TDT1530
	50-57		TDT1530

+ Fan cooling required - see page G2-80.

* Heat exchanger required - see page G2-80.

FEATURES/BENEFITS PAGE G2-3	NOMENCLATURE PAGE G2-11	SELECTION/DIMENSIONS PAGE G2-28	RELATED PRODUCTS PAGE G2-151
--------------------------------	----------------------------	------------------------------------	---------------------------------

SELECTION/DIMENSIONS



TORQUE-ARM Shaft Mount Speed Reducers TXT1 - DOUBLE REDUCTION TAPER BUSHED

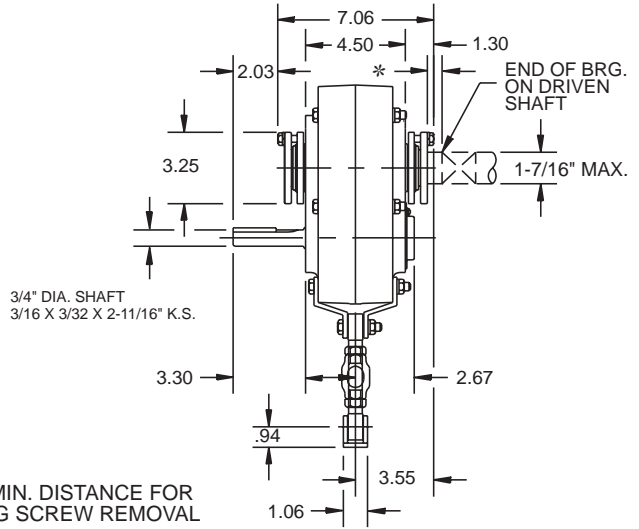
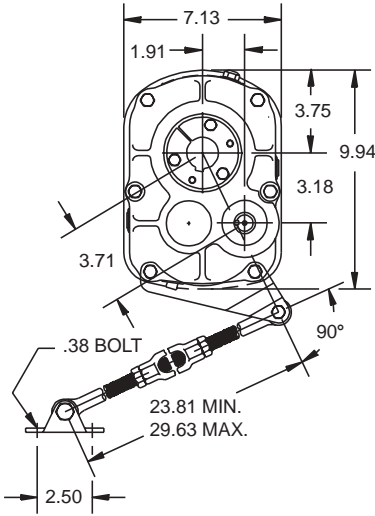

TXT1 - DOUBLE REDUCTION STRAIGHT BORE

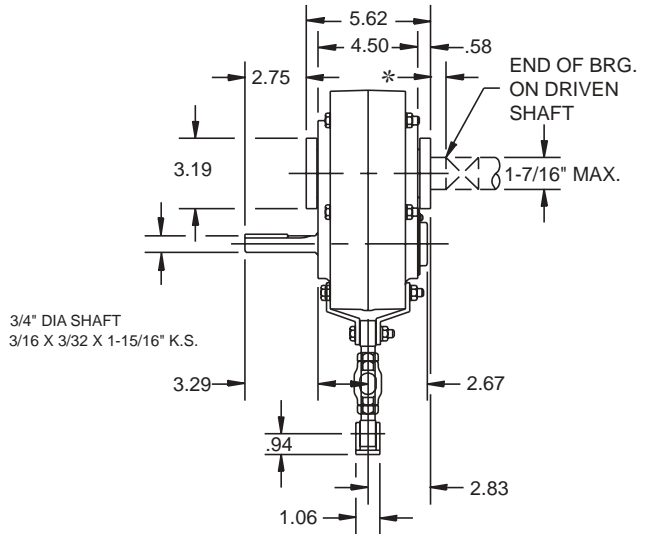
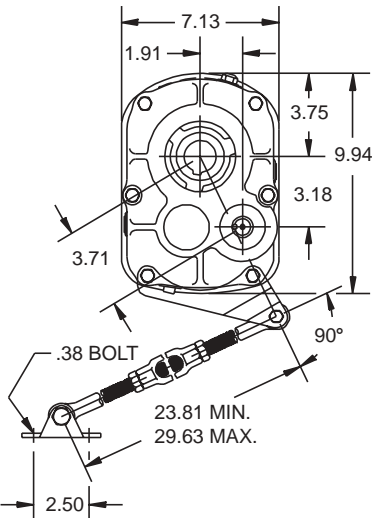

FEATURES/BENEFITS PAGE G2-3	NOMENCLATURE PAGE G2-11	SELECTION PAGE G2-13	RELATED PRODUCTS PAGE G2-152
--------------------------------	----------------------------	-------------------------	---------------------------------

SELECTION/DIMENSIONS



TORQUE-ARM Shaft Mount Speed Reducers

TXT1 Taper Bushed Reducers ■ ○

Reducer Size	Part Number	AGMA Code	Actual Ratio	Weight
TXT109T	241092	107D09	9.44	45
TXT115T	241065	107D15	15.35	45
TXT125T	241066	107D25	25.64	45

TXT1 Straight Bore Reducers ■ ○

Reducer Size	Part Number	AGMA Code	Actual Ratio	Weight
TXT109S	241327 ♣	107D09	9.44	45
TXT115S	241073	107D15	15.35	45
TXT125S	241074	107D25	25.64	45

TXT1 Bushing Assemblies ●

Stock Bore Size	Part Number		Shaft Keyseat Required †			Weight	
	Tapered Bushing	Straight Bore Bushing	Tapered Bushing	Straight Bore Bushing	Tapered Bushing	Straight Bore Bushing	
1-7/16 (Max.)	241292	◆	3/8x3x16x6-7/16	3/8x3/16x2	2	-	
1-3/8	241294	-	5/16 x 5/32 x 6-7/16	-	1.8	-	
1-5/16 ▲	241290	241347	5/16 x 5/32 x 6-7/16	5/16 x 5/32 x 2	1.8	.4	
1-1/4 ▲	241288	241346	1/4 x 1/8 x 6-7/16	1/4 x 1/8 x 2	2.0	.6	
1-3/16 ▲	241286	241345	1/4 x 1/8 x 6-7/16	1/4 x 1/8 x 2	2.2	.6	
1-1/8 ▲	241282	241344	1/4 x 1/8 x 6-7/16	1/4 x 1/8 x 1-3/4	2.2	.6	
1 ▲	241278	241342	1/4 x 1/8 x 6-7/16	1/4 x 1/8 x 1-3/4	2.5	1	

♣ Made to order.

† Shaft key furnished.

▲ Check the driven shaft and key for strength.

◆ Preferred bore. No bushing required for this bore size.

○ Stock TXT1 Reducers are drilled for vertical mounting.

■ See page G2-201 for reducer part numbers and drill and tap dimensions. for Flange Mount TXT Reducers. Now available only as special factory order.

● Taper Bushed Reducers require bushing for all bore sizes.

♥ Use with Taper Bushed Reducers only. See page G2-203 for drill and tap information required to mount to reducer.

TXT1 Accessories

Description	Part Number	Weight
TA1M Standard Motor Mount (56T-215T)	241391	37.3
TAB1 Bottom Motor Mount (56T-215T)	241421	34
TXT1 Backstop Assembly	242101	.8
Optional Filter Breather (3/8-18 NPT)	430048	.2
TXT1-D TA Reducer Belt Guard (56T-215T)	241395	30
TXT1 Taconite Auxiliary Seal Kit ♥	272515	4.40

FEATURES/BENEFITS PAGE G2-3	NOMENCLATURE PAGE G2-11	SELECTION PAGE G2-13	RELATED PRODUCTS PAGE G2-152
--------------------------------	----------------------------	-------------------------	---------------------------------

SELECTION/DIMENSIONS



TORQUE-ARM Shaft Mount Speed Reducers TXT105 - SINGLE REDUCTION TAPER BUSHED

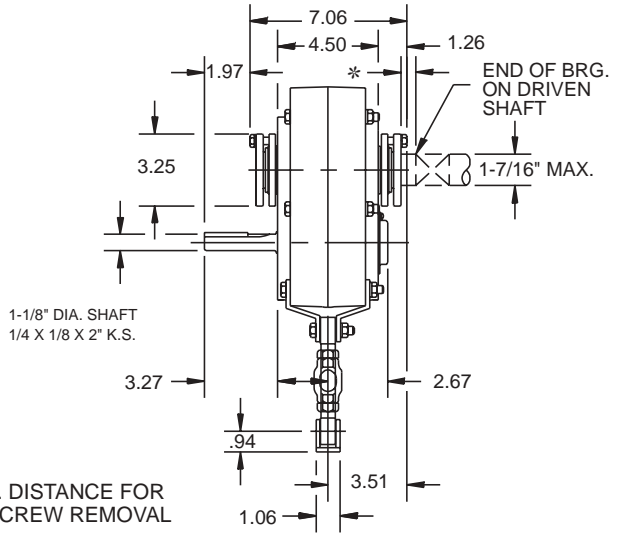
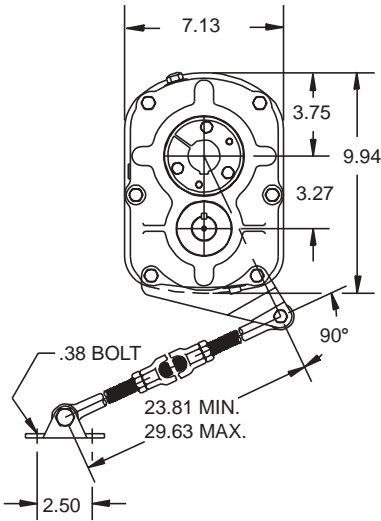

TXT105 - SINGLE REDUCTION STRAIGHT BORE

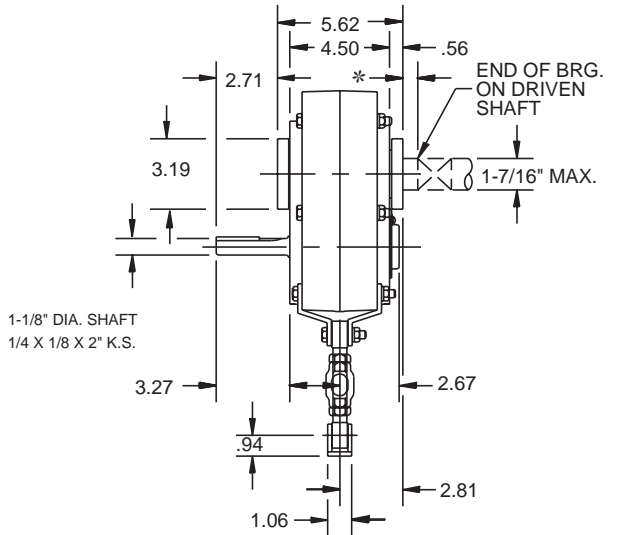
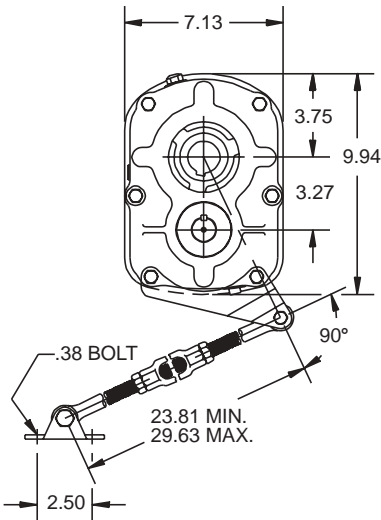

FEATURES/BENEFITS PAGE G2-3	NOMENCLATURE PAGE G2-11	SELECTION PAGE G2-13	RELATED PRODUCTS PAGE G2-152
--------------------------------	----------------------------	-------------------------	---------------------------------



TORQUE-ARM Shaft Mount Speed Reducers

TXT105 Taper Bushed Reducers ■ ○

Reducer Size	Part Number	AGMA Code	Actual Ratio	Weight
TXT105T	241083	107S05	5.62	40

TXT105 Straight Bore Reducers ■ ○

Reducer Size	Part Number	AGMA Code	Actual Ratio	Weight
TXT105S	241087	107S05	5.62	40

TXT105 Accessories

Description	Part Number	Weight
TA1M Standard Motor Mount (56T-215T)	241391	37.3
TAB1 Bottom Motor Mount (56T-215T) †	241421	34
TXT105 Backstop Assembly	242101	.8
Optional Filter Breather (3/8-18 NPT)	430048	.2
TXT1-S TA Reducer Belt Guard (56T-215T)	241397	30
TXT105 Taconite Auxiliary Seal Kit ♥	272521	5

TXT1 Bushing Assemblies ●

Stock Bore Size	Part Number		Shaft Keyseat Required †		Weight	
	Tapered Bushing	Straight Bore Bushing	Tapered Bushing	Straight Bore Bushing	Tapered Bushing	Straight Bore Bushing
1-7/16 (Max.)	241292	◆	3/8 x 3/16 x 6-7/16	3/8 x 3/16 x 2	2	-
1-3/8	241294	-	5/16 x 5/32 x 6-7/16	-	1.8	-
1-5/16 ▲	241290	241347	5/16 x 5/32 x 6-7/16	5/16 x 5/32 x 2	1.8	.4
1-1/4 ▲	241288	241346	1/4 x 1/8 x 6-7/16	1/4 x 1/8 x 2	2	.6
1-3/16 ▲	241286	241345	1/4 x 1/8 x 6-7/16	1/4 x 1/8 x 2	2.2	.6
1-1/8 ▲	241282	241344	1/4 x 1/8 x 6-7/16	1/4 x 1/8 x 1-3/4	2.2	.6
1 ▲	241278	241342	1/4 x 1/8 x 6-7/16	1/4 x 1/8 x 1-3/4	2.5	1

‡ DODGE standard belt guards will not fit this motor mount.

† Shaft key furnished.

▲ Check the driven shaft and key for strength.

◆ Preferred bore. No bushing required for this bore size.

○ Stock TXT105 Reducers are drilled for vertical mounting.

■ See page G2-201 for reducer part numbers and drill and tap dimensions. for Flange Mount TXT Reducers. Now available only as special factory order.

● Taper Bushed Reducers require bushing for all bore sizes.

♥ Use with Taper Bushed Reducer only. See page G2-203 for drill and tap information required to mount to reducer.

FEATURES/BENEFITS PAGE G2-3	NOMENCLATURE PAGE G2-11	SELECTION PAGE G2-13	RELATED PRODUCTS PAGE G2-152
--------------------------------	----------------------------	-------------------------	---------------------------------

SELECTION/DIMENSIONS



TORQUE-ARM Shaft Mount Speed Reducers TXT2 - DOUBLE REDUCTION TAPER BUSHED

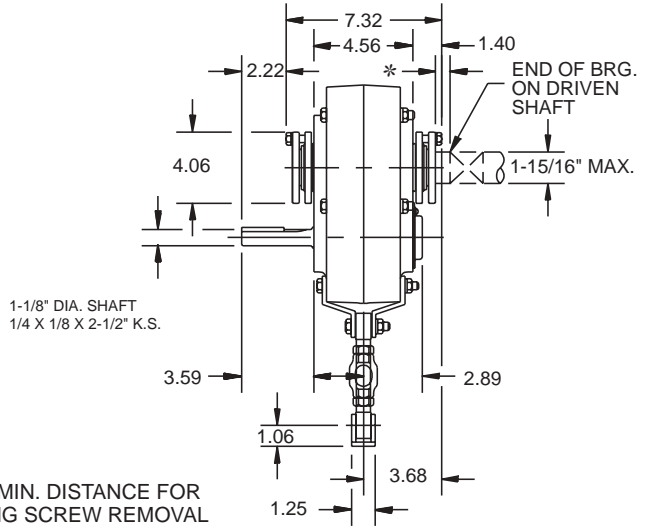
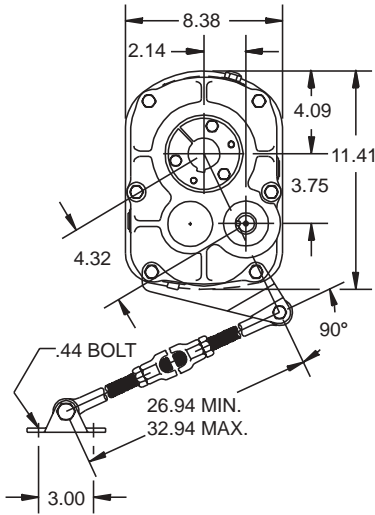

TXT2 - DOUBLE REDUCTION STRAIGHT BORE

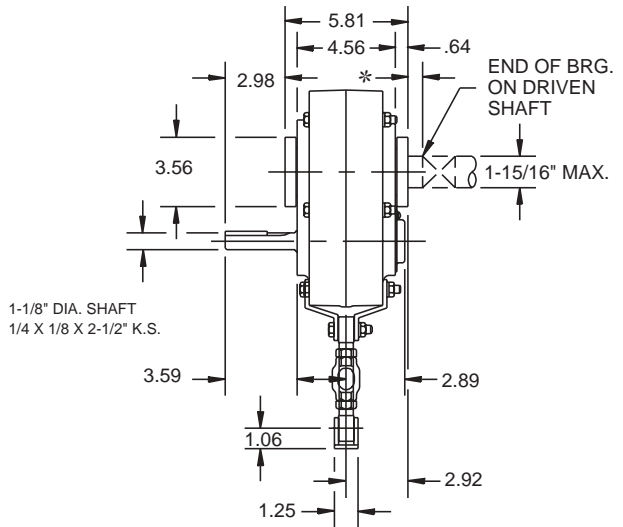
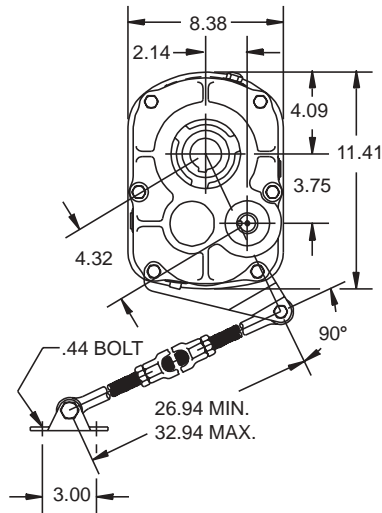

FEATURES/BENEFITS PAGE G2-3	NOMENCLATURE PAGE G2-11	SELECTION PAGE G2-13	RELATED PRODUCTS PAGE G2-152
--------------------------------	----------------------------	-------------------------	---------------------------------

SELECTION/DIMENSIONS



TORQUE-ARM Shaft Mount Speed Reducers

TXT2 Taper Bushed Reducers ■ ○

Reducer Size	Part Number	AGMA Code	Actual Ratio	Weight
TXT209T	242079	115D09	9.25	58
TXT215T	242082	115D15	14.10	58
TXT225T	242083	115D25	23.46	58

TXT2 Straight Bore Reducers ■ ○

Reducer Size	Part Number	AGMA Code	Actual Ratio	Weight
TXT209S	242327 ♣	115D09	9.25	58
TXT215S	242090	115D15	14.10	58
TXT225S	242091	115D25	23.46	58

TXT2 Accessories

Description	Part Number	Weight
TA1M Standard Motor Mount (56T-215T)	241391	37.3
TAB2 Bottom Motor Mount (56T-215T) ♣	242421	34
TXT2 Backstop Assembly	252101	1
Optional Filter Breather (3/8-18 NPT)	430048	.2
TXT2-D TA Reducer Belt Guard (56T-215T)	242395	36
TXT2 Taconite Auxiliary Seal Kit ♥	272446	5.5

TXT2 Bushing Assemblies ●

Stock Bore Size	Part Number		Shaft Keyseat Required †		Weight	
	Tapered Bushing	Straight Bore Bushing	Tapered Bushing	Straight Bore Bushing	Tapered Bushing	Straight Bore Bushing
1-15/16 (Max.)	242168	◆	1/2 x 1/4 x 6-11/16	1/2 x 1/4 x 2-1/2	2.9	-
1-3/4	242166	242351	3/8 x 3/16 x 6-11/16	3/8 x 3/16 x 2-7/8	3.3	.8
1-11/16	242164	242350	3/8 x 3/16 x 6-11/16	3/8 x 3/16 x 2-7/8	3.4	1.1
1-5/8 ▲	242162	242349	3/8 x 3/16 x 6-11/16	3/8 x 3/16 x 2-7/8	3.2	1.2
1-1/2 ▲	242158	242348	3/8 x 3/16 x 6-11/16	3/8 x 3/16 x 2-1/2	3.8	1.5
1-7/16 ▲	242156	242347	3/8 x 3/16 x 6-11/16	3/8 x 3/16 x 2-1/2	4	1.7
1-3/8 ▲	242154	242346	5/16 x 5/32 x 6-11/16	5/16 x 5/32 x 2	3.6	1.8
1-5/16 ▲	242152	242345	5/16 x 5/32 x 6-11/16	5/16 x 5/32 x 2	3.6	1.8
1-1/4 ▲	242150	242344	1/4 x 1/8 x 6-11/16	1/4 x 1/8 x 2	3.6	2.1
1-3/16 ▲	242148	242343	1/4 x 1/8 x 6-11/16	1/4 x 1/8 x 2	3.6	2.2
1-1/8 ▲	242146	-	1/4 x 1/8 x 6-11/16	-	3.8	-

♣ DODGE standard belt guards will not fit this motor mount.

† Shaft key furnished.

▲ Check the driven shaft and key for strength.

◆ Preferred bore. No bushing required for this bore size.

○ Stock TXT2 Reducers are drilled for vertical mounting.

♣ Made to order.

■ See page G2-201 for reducer part numbers and drill and tap dimensions. for Flange Mount TXT Reducers. Now available only as special factory order.

● Taper Bushed Reducers require bushing for all bore sizes.

♥ Use with Taper Bushed Reducer only. See page G2-203 for drill and tap information required to mount to reducer.

FEATURES/BENEFITS PAGE G2-3	NOMENCLATURE PAGE G2-11	SELECTION PAGE G2-13	RELATED PRODUCTS PAGE G2-152
--------------------------------	----------------------------	-------------------------	---------------------------------

SELECTION/DIMENSIONS



TORQUE-ARM Shaft Mount Speed Reducers TXT205 - SINGLE REDUCTION TAPER BUSHED

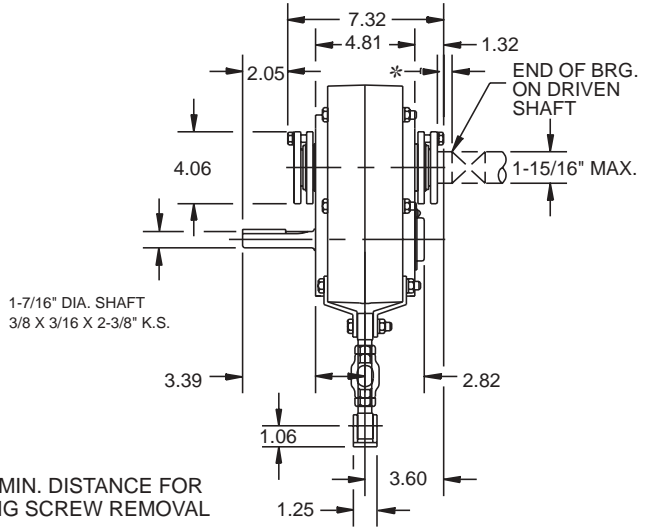
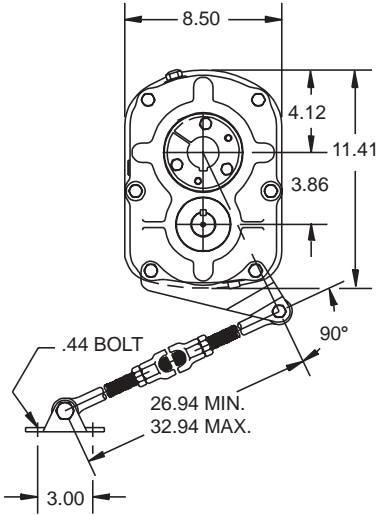

* 1.25" MIN. DISTANCE FOR BUSHING SCREW REMOVAL

TXT205 - SINGLE REDUCTION STRAIGHT BORE

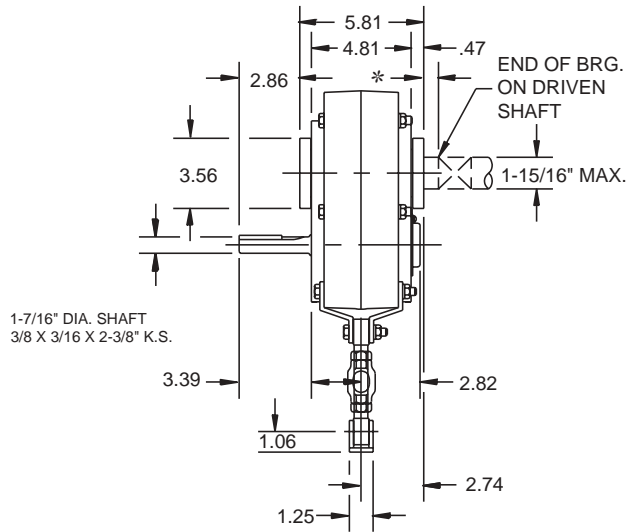
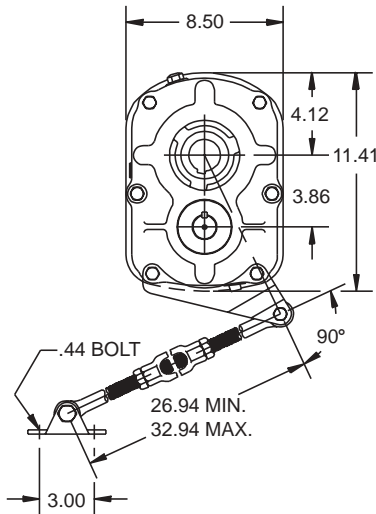

FEATURES/BENEFITS PAGE G2-3	NOMENCLATURE PAGE G2-11	SELECTION PAGE G2-13	RELATED PRODUCTS PAGE G2-152
--------------------------------	----------------------------	-------------------------	---------------------------------

SELECTION/DIMENSIONS



TORQUE-ARM Shaft Mount Speed Reducers

TXT205 Taper Bushed Reducers ■ ○

Reducer Size	Part Number	AGMA Code	Actual Ratio	Weight
TXT205T	242249	115S05	5.29	52

TXT205 Straight Bore Reducers ■ ○

Reducer Size	Part Number	AGMA Code	Actual Ratio	Weight
TXT205S	242253	115S05	5.29	52

TXT205 Accessories

Description	Part Number	Weight
TA1M Standard Motor Mount (56T-215T)	241391	37.3
TAB2 Bottom Motor Mount (56T-215T) ♣	242421	34
TXT205 Backstop Assembly	252101	1
Optional Filter Breather (3/8-18 NPT)	430048	0.2
TXT2-S TA Reducer Belt Guard (56T-215T)	242397	36
TXT205 Taconite Auxiliary Seal Kit ♥	272459	5.8

TXT2 Bushing Assemblies ●

Stock Bore Size		Part Number		Shaft Keyseat Required †		Weight	
		Tapered Bushing	Straight Bore Bushing	Tapered Bushing	Straight Bore Bushing	Tapered Bushing	Straight Bore Bushing
1-15/16	(Max.)	242168	◆	1/2 x 1/4 x 6-11/16	1/2 x 1/4 x 2-1/2	2.9	-
1-3/4		242166	242351	3/8 x 3/16 x 6-11/16	3/8 x 3/16 x 2-7/8	3.3	.8
1-11/16		242164	242350	3/8 x 3/16 x 6-11/16	3/8 x 3/16 x 2-7/8	3.4	1.1
1-5/8	▲	242162	242349	3/8 x 3/16 x 6-11/16	3/8 x 3/16 x 2-7/8	3.2	1.2
1-1/2	▲	242158	242348	3/8 x 3/16 x 6-11/16	3/8 x 3/16 x 2-1/2	3.8	1.5
1-7/16	▲	242156	242347	3/8 x 3/16 x 6-11/16	3/8 x 3/16 x 2-1/2	4	1.7
1-3/8	▲	242154	242346	5/16 x 5/32 x 6-11/16	5/16 x 5/32 x 2	3.6	1.8
1-5/16	▲	242152	242345	5/16 x 5/32 x 6-11/16	5/16 x 5/32 x 2	3.6	1.8
1-1/4	▲	242150	242344	1/4 x 1/8 x 6-11/16	1/4 x 1/8 x 2	3.6	2.1
1-3/16	▲	242148	242343	1/4 x 1/8 x 6-11/16	1/4 x 1/8 x 2	3.6	2.2
1-1/8	▲	242146	-	1/4 x 1/8 x 6-11/16	-	3.8	-

♣ DODGE standard belt guards will not fit this motor mount.

† Shaft key furnished.

▲ Check the driven shaft and key for strength.

◆ Preferred bore. No bushing required for this bore size.

○ Stock TXT205 Reducers are drilled for vertical mounting.

♣ Made to order.

■ See page G2-201 for reducer part numbers and drill and tap dimensions. for Flange Mount TXT Reducers. Now available only as special factory order.

● Taper Bushed Reducers require bushing for all bore sizes.

♥ Use with Taper Bushed Reducder only. See page G2-203 for drill and tap information required to mount to reducer.

FEATURES/BENEFITS PAGE G2-3	NOMENCLATURE PAGE G2-11	SELECTION PAGE G2-13	RELATED PRODUCTS PAGE G2-152
--------------------------------	----------------------------	-------------------------	---------------------------------

SELECTION/DIMENSIONS



TORQUE-ARM Shaft Mount Speed Reducers TXT3A -DOUBLE REDUCTION TAPER BUSHED

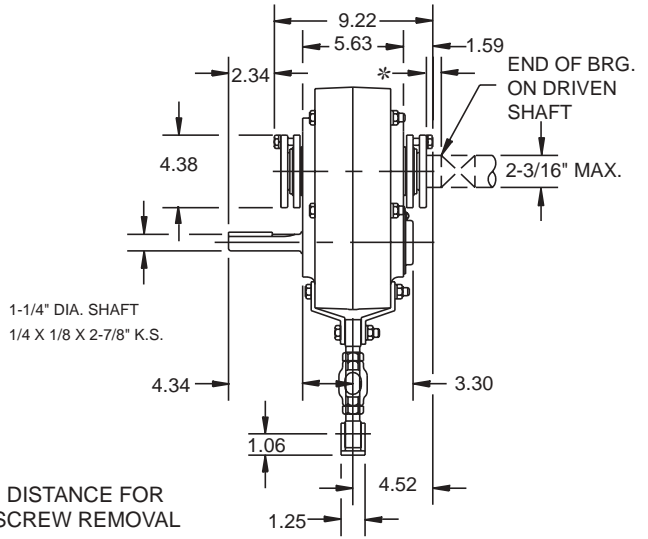
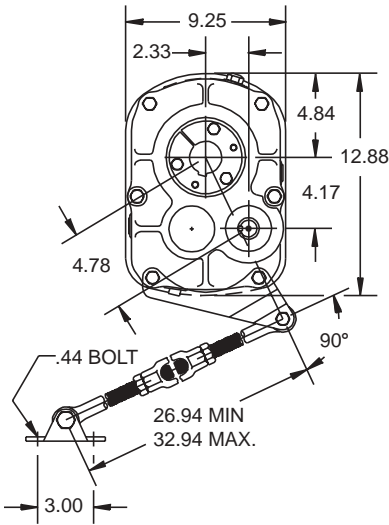

TXT3A - DOUBLE REDUCTION STRAIGHT BORE

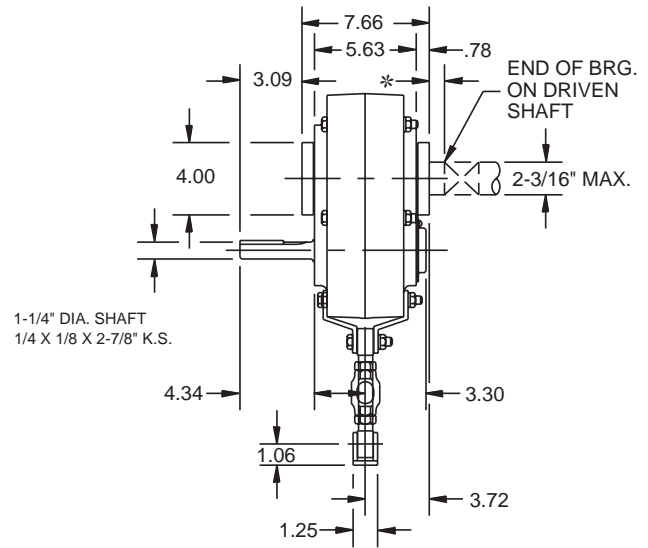
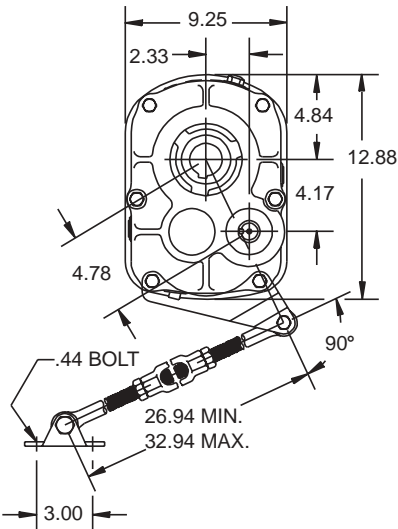

FEATURES/BENEFITS PAGE G2-3	NOMENCLATURE PAGE G2-11	SELECTION PAGE G2-13	RELATED PRODUCTS PAGE G2-152
--------------------------------	----------------------------	-------------------------	---------------------------------



TORQUE-ARM Shaft Mount Speed Reducers

TXT3A Taper Bushed Reducers ■ ○

Reducer Size	Part Number	AGMA Code	Actual Ratio	Weight
TXT309AT	243500	203D09	8.91	98
TXT315AT	243501	203D15	14.88	98
TXT325AT	243502	203D25	24.71	98

TXT3A Straight Bore Reducers ■ ○

Reducer Size	Part Number	AGMA Code	Actual Ratio	Weight
TXT309AS	243512 ♣	203D09	8.91	98
TXT315AS	243513	203D15	14.88	98
TXT325AS	243514	203D25	24.71	98

TXT3A Accessories

Description	Part Number	Weight
TA3M Standard Motor Mount (56T-215T)	243391	38
TA3M Special Motor Mount (254T-256T) ♠	243393	45
TA3ML Long Motor Mount (143T-215T)	243392	42
TAB3 Bottom Motor Mount (143T-286T) ♠	243404	54
TXT3A Backstop Assembly	243106	.6
Optional Filter Breather (3/8-18 NPT)	430048	.2
TXT3-D TA Reducer Belt Guard (56T-215T)	243387	43
TXT3-D TA Reducer Belt Guard for Long Motor Mount (56T-215T) ♣	243153	52
TXT3A Cooling Fan Assembly	243581	3
TXT3A Taconite Auxiliary Seal Kit ♥	243577	7.3

TXT3 Bushing Assemblies ●

Stock Bore Size		Part Number		Shaft Keyseat Required †		Weight	
		Tapered Bushing	Straight Bore Bushing	Tapered Bushing	Straight Bore Bushing	Tapered Bushing	Straight Bore Bushing
2-3/16	(Max.)	243276	◆	1/2 x 1/4 x 8-1/16	1/2 x 1/4 x 3-5/8	3.7	-
2		243274	243429	1/2 x 1/4 x 8-1/16	1/2 x 1/4 x 3-5/8	4.1	1
1-15/16		243272	243428	1/2 x 1/4 x 8-1/16	1/2 x 1/4 x 3-5/8	4.4	1.2
1-7/8	▲	243270	243427	1/2 x 1/4 x 8-1/16	1/2 x 1/4 x 3-5/8	4.3	1.9
1-3/4	▲	243266	243426	3/8 x 3/16 x 8-1/16	3/8 x 3/16 x 3-1/4	4.8	1.9
1-11/16	▲	243268	243425	3/8 x 3/16 x 8-1/16	3/8 x 3/16 x 3-1/4	4.8	2.2
1-5/8	▲	243264	243424	3/8 x 3/16 x 8-1/16	3/8 x 3/16 x 2-1/4	4.8	2.3
1-1/2	▲	243262	243423	3/8 x 3/16 x 8-1/16	3/8 x 3/16 x 2-1/4	5.4	2.5
1-7/16	▲	243260	243422	3/8 x 3/16 x 8-1/16	3/8 x 3/16 x 2-1/4	5.6	2.7
1-3/8	▲	243284	243421	5/16 x 5/32 x 8-1/16	5/16 x 5/32 x 2-1/4	5.8	3.2
1-5/16	▲	243282	243420	5/16 x 5/32 x 8-1/16	5/16 x 5/32 x 2-1/4	5.8	3.8

♠ DODGE standard belt guards will not fit this motor mount. ■ See page G2-201 for reducer part numbers and drill and tap dimensions.

† Shaft key furnished.

▲ Check the driven shaft and key for strength.

◆ Preferred bore. No bushing required for this bore size.

○ Stock TXT3 Reducers are drilled for vertical mounting.

♣ Made to order.

● Taper Bushed Reducers require bushing for all bore sizes.

♥ Use with Taper Bushed Reducers only. See page G2-203 for drill and tap information required to mount to reducer.

FEATURES/BENEFITS PAGE G2-3	NOMENCLATURE PAGE G2-11	SELECTION PAGE G2-13	RELATED PRODUCTS PAGE G2-152
--------------------------------	----------------------------	-------------------------	---------------------------------

SELECTION/DIMENSIONS



TORQUE-ARM Shaft Mount Speed Reducers TXT305A - SINGLE REDUCTION TAPER BUSHED

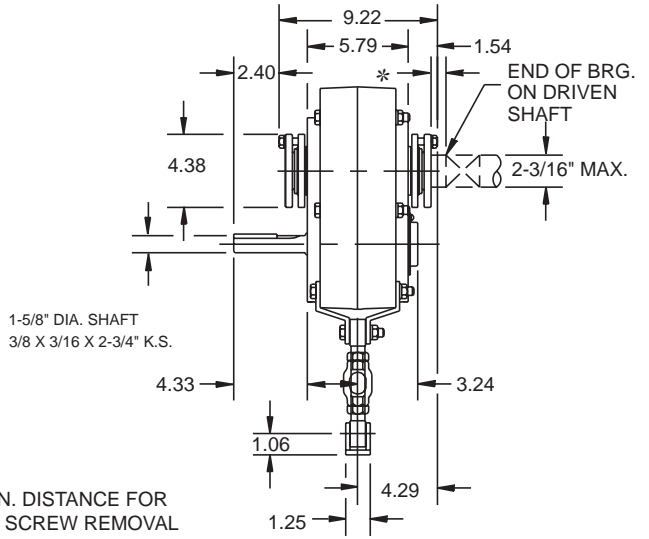
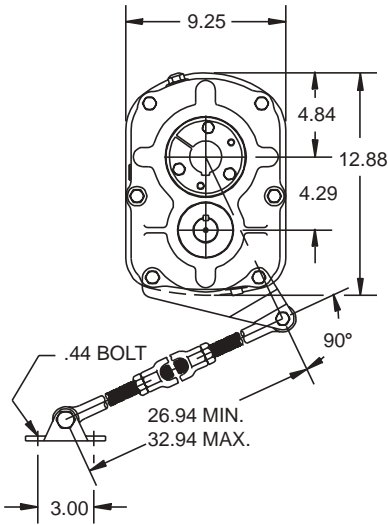

TXT305A - SINGLE REDUCTION STRAIGHT BORE

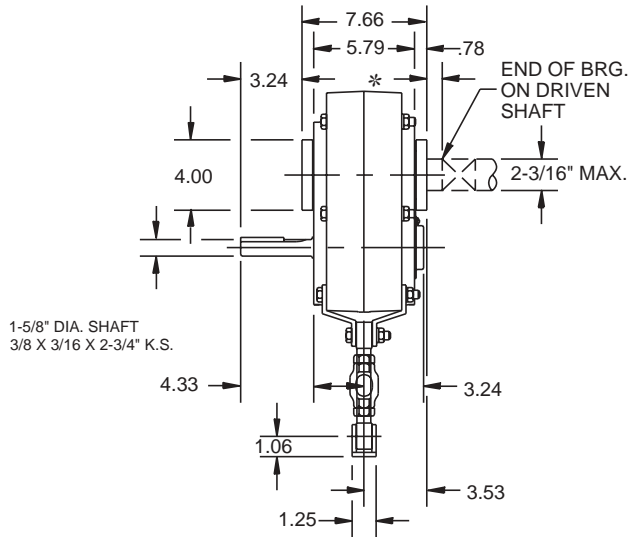
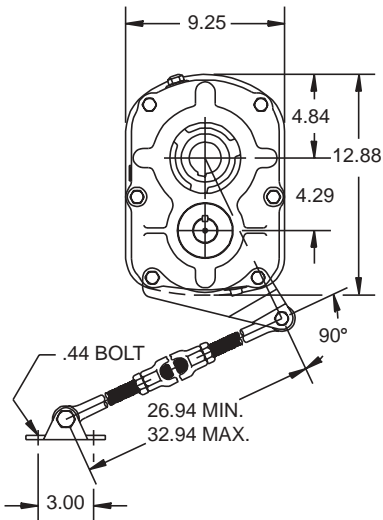

FEATURES/BENEFITS PAGE G2-3	NOMENCLATURE PAGE G2-11	SELECTION PAGE G2-13	RELATED PRODUCTS PAGE G2-152
--------------------------------	----------------------------	-------------------------	---------------------------------

SELECTION/DIMENSIONS



TORQUE-ARM Shaft Mount Speed Reducers

TXT305A Taper Bushed Reducers ■ ○

Reducer Size	Part Number	AGMA Code	Actual Ratio	Weight
TXT305AT	253151	203S05	5.60	86

TXT305A Straight Bore Reducers ■ ○

Reducer Size	Part Number	AGMA Code	Actual Ratio	Weight
TXT305AS	253155	203S05	5.60	86

TXT305A Accessories

Description	Part Number	Weight
TA3M Standard Motor Mount (56T-215T)	243391	38
TA3M Special Motor Mount (254T-256T) †	243393	45
TA3ML Long Motor Mount (143T-215T)	243392	42
TAB3 Bottom Motor Mount (143T-286T) †	243404	54
TXT305A Backstop Assembly	252101	1
Optional Filter Breather (3/8-18 NPT)	430048	.2
TXT3-S TA Reducer Belt Guard (56T-215T)	243389	43
TXT3-S TA Reducer Belt Guard for Long Motor Mount (56T-215T) †	243164	55
TXT305A Cooling Fan Assembly	253188	3
TXT305A Taconite Auxiliary Seal Kit ♥	253186	7.6

TXT3 Bushing Assemblies ●

Stock Bore Size	Part Number		Shaft Keyseat Required †		Weight	
	Tapered Bushing	Straight Bore Bushing	Tapered Bushing	Straight Bore Bushing	Tapered Bushing	Straight Bore Bushing
2-3/16 (Max.)	243276	◆	1/2 x 1/4 x 8-1/16	1/2 x 1/4 x 3-5/8	3.7	-
2	243274	243429	1/2 x 1/4 x 8-1/16	1/2 x 1/4 x 3-5/8	4.1	1
1-15/16	243272	243428	1/2 x 1/4 x 8-1/16	1/2 x 1/4 x 3-5/8	4.4	1.2
1-7/8 ▲	243270	243427	1/2 x 1/4 x 8-1/16	1/2 x 1/4 x 3-5/8	4.3	1.9
1-3/4 ▲	243266	243426	3/8 x 3/16 x 8-1/16	3/8 x 3/16 x 3-1/4	4.8	1.9
1-11/16 ▲	243268	243425	3/8 x 3/16 x 8-1/16	3/8 x 3/16 x 3-1/4	4.8	2.2
1-5/8 ▲	243264	243424	3/8 x 3/16 x 8-1/16	3/8 x 3/16 x 2-1/4	4.8	2.3
1-1/2 ▲	243262	243423	3/8 x 3/16 x 8-1/16	3/8 x 3/16 x 2-1/4	5.4	2.5
1-7/16 ▲	243260	243422	3/8 x 3/16 x 8-1/16	3/8 x 3/16 x 2-1/4	5.6	2.7
1-3/8 ▲	243284	243421	5/16 x 5/32 x 8-1/16	5/16 x 5/32 x 2-1/4	5.8	3.2
1-5/16 ▲	243282	243420	5/16 x 5/32 x 8-1/16	5/16 x 5/32 x 2-1/4	5.8	3.8

† DODGE standard belt guards will not fit this motor mount.

† Shaft key furnished.

▲ Check the driven shaft and key for strength.

◆ Preferred bore. No bushing required for this bore size.

○ Stock TXT305 Reducers are drilled for vertical mounting.

♣ Made to order.

■ See page G2-201 for reducer part numbers and drill and tap dimensions. for Flange Mount TXT Reducers. Now available only as special factory order.

● Taper Bushed Reducers require bushing for all bore sizes.

♥ Use with Taper Bushed Reducer only. See page G2-203 for drill and tap information required to mount to reducer.

FEATURES/BENEFITS PAGE G2-3	NOMENCLATURE PAGE G2-11	SELECTION PAGE G2-13	RELATED PRODUCTS PAGE G2-152
--------------------------------	----------------------------	-------------------------	---------------------------------

SELECTION/DIMENSIONS



TORQUE-ARM Shaft Mount Speed Reducers TXT4A - DOUBLE REDUCTION TAPER BUSHED

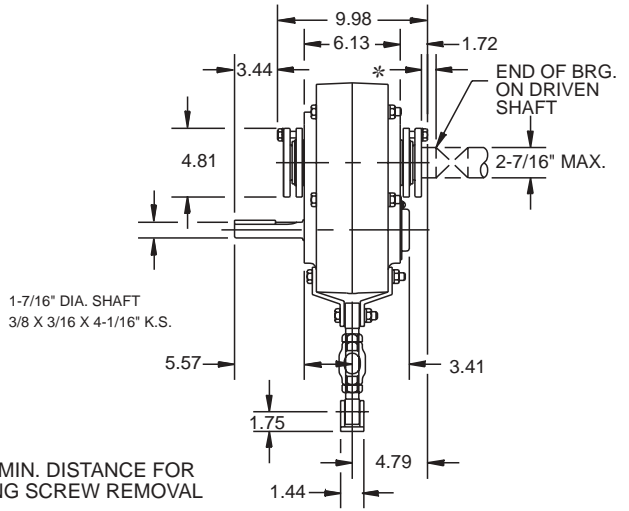
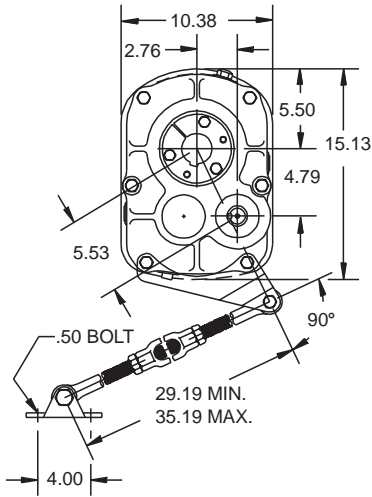

TXT4A - DOUBLE REDUCTION STRAIGHT BORE

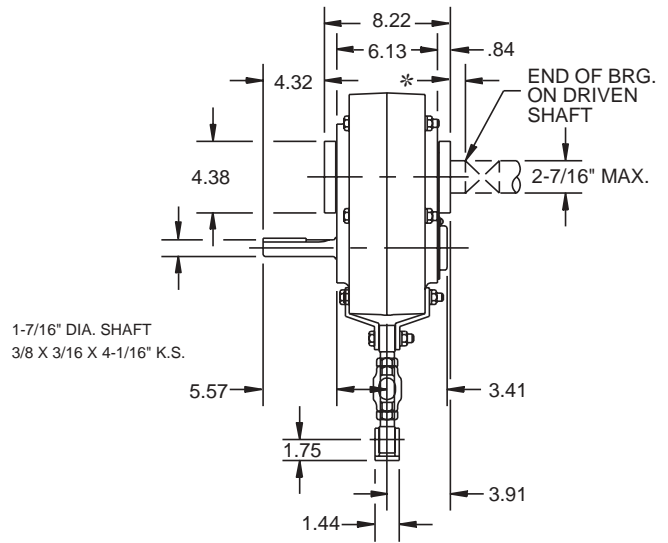
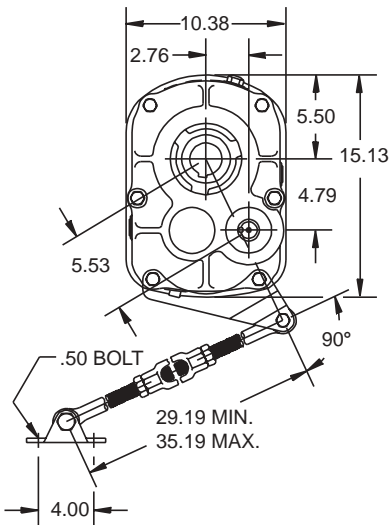



TORQUE-ARM Shaft Mount Speed Reducers

TXT4A Taper Bushed Reducers ■ ○

Reducer Size	Part Number	AGMA Code	Actual Ratio	Weight
TXT409AT	244525	207D09	9.67	139
TXT415AT	244526	207D15	15.13	139
TXT425AT	244527	207D25	24.38	139

TXT4A Straight Bore Reducers ■ ○

Reducer Size	Part Number	AGMA Code	Actual Ratio	Weight
TXT409AS	244537 ♣	207D09	9.67	139
TXT415AS	244538	207D15	15.13	139
TXT425AS	244539	207D25	24.38	139

TXT4A Accessories

Description	Part Number	Weight
TA4M Standard Motor Mount (143T-286T)	244391	75
TA4ML Long Motor Mount (143T-286T)	244392	75
TAB4 Bottom Motor Mount (143T-326T) ♠	244404	55
TXT4A Backstop Assembly	244106	1.2
Optional Filter Breather (3/8-18 NPT)	430048	.2
TXT4-D TA Reducer Belt Guard (143T-286T)	244395	54
TXT4-D TA Reducer Belt Guard for Long Motor Mount (143T-286T) ♠	244151	65
TXT4A Cooling Fan Assembly	272594	3
TXT4A Taconite Auxiliary Seal Kit ♥	244676	7.7

TXT4 Bushing Assemblies ●

Stock Bore Size	Part Number		Shaft Keyseat Required †		Weight	
	Tapered Bushing	Straight Bore Bushing	Tapered Bushing	Straight Bore Bushing	Tapered Bushing	Straight Bore Bushing
2-7/16 (Max.)	244115	◆	5/8 x 5/16 x 9-1/32	5/8 x 5/16 x 3-3/8	5.8	-
2-1/4 ▲	244113	244430	1/2 x 1/4 x 9-1/32	1/2 x 1/4 x 3-3/8	6.3	1.2
2-3/16 ▲	244111	244429	1/2 x 1/4 x 9-1/32	1/2 x 1/4 x 3-3/8	6.7	1.5
2-1/8 ▲	244109	244428	1/2 x 1/4 x 9-1/32	1/2 x 1/4 x 3-3/8	7	2.6
2 ▲	244095	244427	1/2 x 1/4 x 9-1/32	1/2 x 1/4 x 4	7.1	2.6
1-15/16 ▲	244093	244426	1/2 x 1/4 x 9-1/32	1/2 x 1/4 x 4	7.4	3.5
1-3/4 ▲	244087	244424	3/8 x 3/16 x 9-1/32	3/8 x 3/16 x 2-7/16	8	3.6
1-11/16 ▲	244085	244423	3/8 x 3/16 x 9-1/32	3/8 x 3/16 x 2-7/16	8.3	3.6
1-1/2 ▲	244081	244421	3/8 x 3/16 x 9-1/32	3/8 x 3/16 x 2-7/16	8.3	4.1
1-7/16 ▲	244079	244420	3/8 x 3/16 x 9-1/32	3/8 x 3/16 x 2-7/16	8.8	4.1

♠ DODGE standard belt guards will not fit this motor mount.

† Shaft key furnished.

▲ Check the driven shaft and key for strength.

◆ Preferred bore. No bushing required for this bore size.

○ Stock TXT4 Reducers are drilled for vertical mounting.

♣ Made to order.

■ See page G2-201 for reducer part numbers and drill and tap dimensions. for Flange Mount TXT Reducers. Now available only as special factory order.

● Taper Bushed Reducers require bushing for all bore sizes.

♥ Use with Taper Bushed Reducer only. See page G2-203 for drill and tap information required to mount to reducer.

FEATURES/BENEFITS PAGE G2-3	NOMENCLATURE PAGE G2-11	SELECTION PAGE G2-13	RELATED PRODUCTS PAGE G2-152
--------------------------------	----------------------------	-------------------------	---------------------------------

SELECTION/DIMENSIONS



TORQUE-ARM Shaft Mount Speed Reducers TXT405A - SINGLE REDUCTION TAPER BUSHED

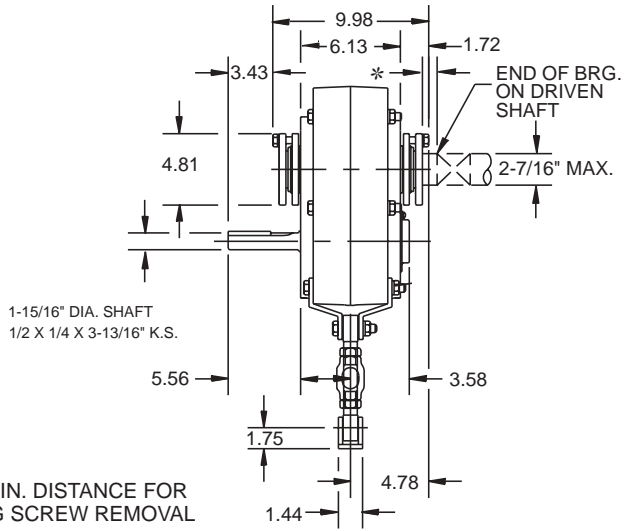
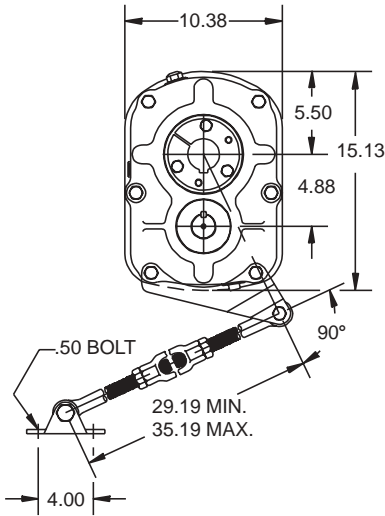

TXT405A - SINGLE REDUCTION STRAIGHT BORE

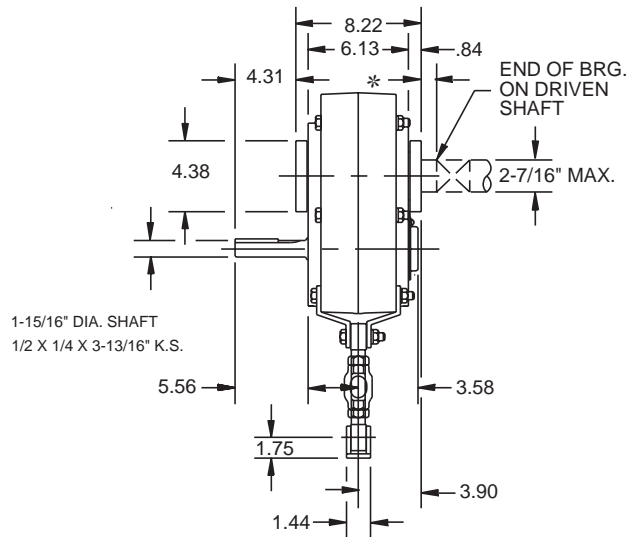
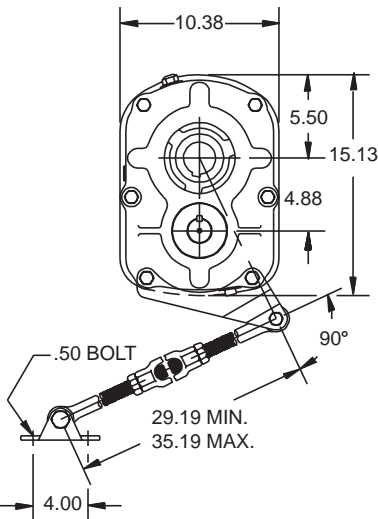

FEATURES/BENEFITS PAGE G2-3	NOMENCLATURE PAGE G2-11	SELECTION PAGE G2-13	RELATED PRODUCTS PAGE G2-152
--------------------------------	----------------------------	-------------------------	---------------------------------

SELECTION/DIMENSIONS



TORQUE-ARM Shaft Mount Speed Reducers

TXT405A Taper Bushed Reducers ■ ○

Reducer Size	Part Number	AGMA Code	Actual Ratio	Weight
TXT405AT	254200	207S05	5.65	122

TXT405A Straight Bore Reducers ■ ○

Reducer Size	Part Number	AGMA Code	Actual Ratio	Weight
TXT405AS	254204	207S05	5.65	122

TXT405A Accessories

Description	Part Number	Weight
TA4M Standard Motor Mount (143T-286T)	244391	75
TA4ML Long Motor Mount (143T-286T)	244392	75
TAB4 Bottom Motor Mount (143T-326T) ♣	244404	55
TXT405A Backstop Assembly	244148	.9
Optional Filter Breather (3/8-18 NPT)	430048	.2
TXT4-S TA Reducer Belt Guard (143T-286T)	244397	54
TXT4-S TA Reducer Belt Guard for Long Motor Mount (143T-286T) ♣	244164	65
TXT405A Cooling Fan Assembly	254268	3
TXT405A Taconite Auxiliary Seal Kit ♥	254267	7.9

TXT4 Bushing Assemblies ●

Stock Bore Size	Part Number		Shaft Keyseat Required †		Weight	
	Tapered Bushing	Straight Bore Bushing	Tapered Bushing	Straight Bore Bushing	Tapered Bushing	Straight Bore Bushing
2-7/16 (Max.)	244115	◆	5/8 x 5/16 x 9-1/32	5/8 x 5/16 x 3-3/8	5.8	-
2-1/4 ▲	244113	244430	1/2 x 1/4 x 9-1/32	1/2 x 1/4 x 3-3/8	6.3	1.2
2-3/16 ▲	244111	244429	1/2 x 1/4 x 9-1/32	1/2 x 1/4 x 3-3/8	6.7	1.5
2-1/8 ▲	244109	244428	1/2 x 1/4 x 9-1/32	1/2 x 1/4 x 3-3/8	7	2.6
2 ▲	244095	244427	1/2 x 1/4 x 9-1/32	1/2 x 1/4 x 4	7.1	2.6
1-15/16 ▲	244093	244426	1/2 x 1/4 x 9-1/32	1/2 x 1/4 x 4	7.4	3.5
1-3/4 ▲	244087	244424	3/8 x 3/16 x 9-1/32	3/8 x 3/16 x 2-7/16	8	3.6
1-11/16 ▲	244085	244423	3/8 x 3/16 x 9-1/32	3/8 x 3/16 x 2-7/16	8.3	3.6
1-1/2 ▲	244081	244421	3/8 x 3/16 x 9-1/32	3/8 x 3/16 x 2-7/16	8.3	4.1
1-7/16 ▲	244079	244420	3/8 x 3/16 x 9-1/32	3/8 x 3/16 x 2-7/16	8.8	4.1

♣ DODGE standard belt guards will not fit this motor mount.

† Shaft key furnished.

▲ Check the driven shaft and key for strength.

◆ Preferred bore. No bushing required for this bore size.

○ Stock TXT405 Reducers are drilled for vertical mounting.

♣ Made to order.

■ See page G2-201 for reducer part numbers and drill and tap dimensions.

for Flange Mount TXT Reducers. Now available only as special factory order.

● Taper Bushed Reducers require bushing for all bore sizes.

♥ Use with Taper Bushed Reducer only. See page G2-203 for drill and tap information required to mount to reducer.

FEATURES/BENEFITS PAGE G2-3	NOMENCLATURE PAGE G2-11	SELECTION PAGE G2-13	RELATED PRODUCTS PAGE G2-152
--------------------------------	----------------------------	-------------------------	---------------------------------



SELECTION/DIMENSIONS

TORQUE-ARM Shaft Mount Speed Reducers TXT5B - DOUBLE REDUCTION TAPER BUSHED

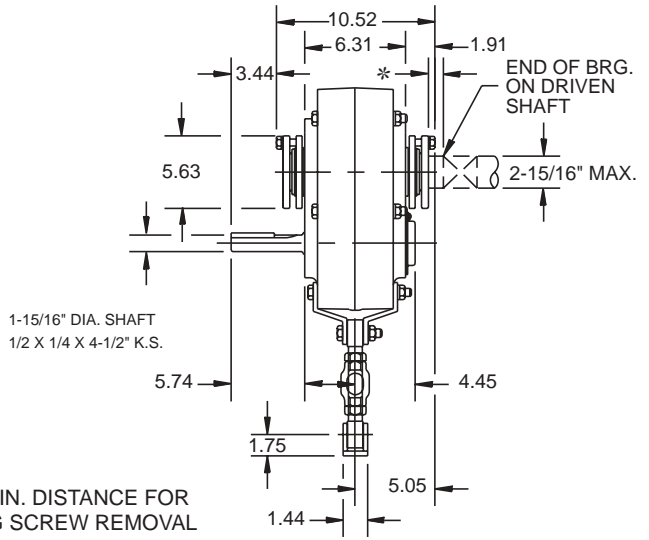
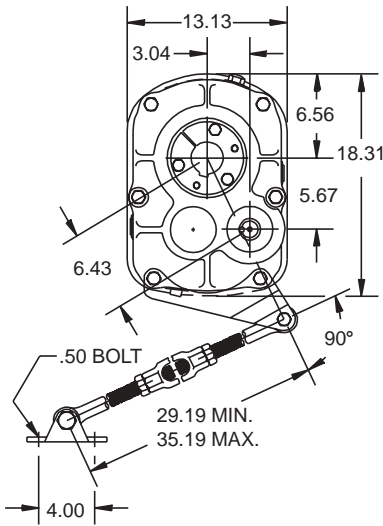

TXT5B - DOUBLE REDUCTION STRAIGHT BORE

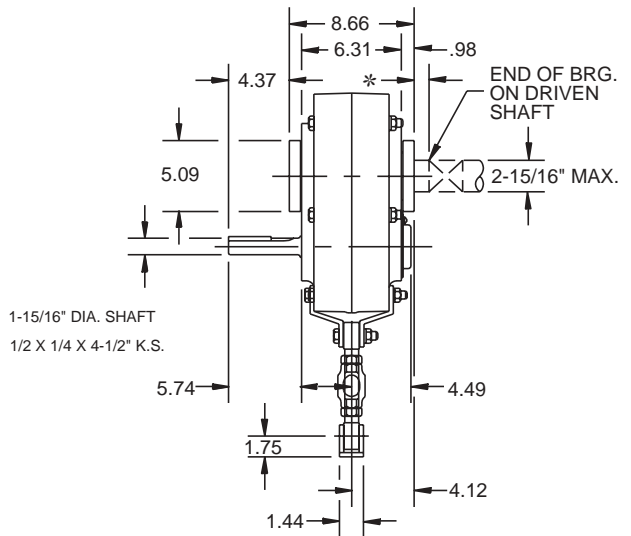
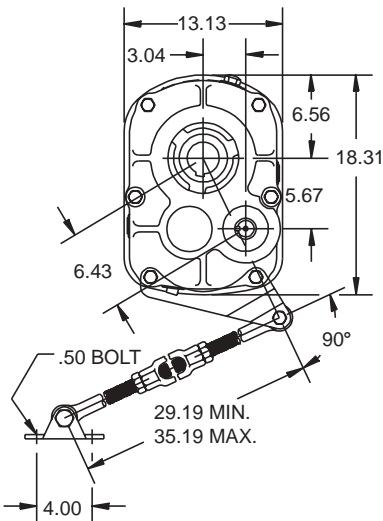

FEATURES/BENEFITS PAGE G2-3	NOMENCLATURE PAGE G2-11	SELECTION PAGE G2-13	RELATED PRODUCTS PAGE G2-152
--------------------------------	----------------------------	-------------------------	---------------------------------

SELECTION/DIMENSIONS



TORQUE-ARM Shaft Mount Speed Reducers

TXT5B Taper Bushed Reducers ■ ○

Reducer Size	Part Number	AGMA Code	Actual Ratio	Weight
TXT509BT	245550	215D09	8.95	207
TXT515BT	245551	215D15	15.40	207
TXT525BT	245552	215D25	25.56	207

TXT5B Straight Bore Reducers ■ ○

Reducer Size	Part Number	AGMA Code	Actual Ratio	Weight
TXT509BS	245562 ♣	215D09	8.95	207
TXT515BS	245563	215D15	15.40	207
TXT525BS	245564	215D25	25.56	207

TXT5B Accessories

Description	Part Number	Weight
TA5M Standard Motor Mount (143T-286T)	245391	76
TA5M Special Motor Mount (324T-326T) ♠	245393	79
TA5ML Long Motor Mount (143T-286T)	245392	89
TAB5 Bottom Motor Mount (143T-326T) ♠	245405	55
TXT5B Backstop Assembly	245154	2.2
Optional Filter Breather (1/2-14 NPT)	430049	.2
TXT5-D TA Reducer Belt Guard (143T-286T)	245387	75
TXT5-D TA Reducer Belt Guard for Long Motor Mount (143T-286T) ♣	245102	90
TXT5B Cooling Fan Assembly	272369	3
TXT5B Taconite Auxiliary Seal Kit ♥	245635	11.9

TXT5 Bushing Assemblies ●

Stock Bore Size	Part Number		Shaft Keyseat Required †		Weight	
	Tapered Bushing	Straight Bore Bushing	Tapered Bushing	Straight Bore Bushing	Tapered Bushing	Straight Bore Bushing
2-15/16 (Max.)	245112	◆	3/4 x 3/8 x 9-3/8	3/4 x 3/8 x 4-3/8	7.8	-
2-11/16	245110	245428	5/8 x 5/16 x 9-3/8	5/8 x 5/16 x 4-3/8	7.9	3
2-1/2 ▲	245099	245427	5/8 x 5/16 x 9-3/8	5/8 x 5/16 x 4-3/8	8.5	3.4
2-7/16 ▲	245094	245426	5/8 x 5/16 x 9-3/8	5/8 x 5/16 x 4-3/8	8.5	4.3
2-1/4 ▲	245092	245425	1/2 x 1/4 x 9-3/8	1/2 x 1/4 x 3	9.2	4.7
2-3/16 ▲	245090	245424	1/2 x 1/4 x 9-3/8	1/2 x 1/4 x 3	10	5.6
2	245088	245423	1/2 x 1/4 x 9-3/8	1/2 x 1/4 x 3	10.2	5.9
1-15/16 ▲	245086	245422	1/2 x 1/4 x 9-3/8	1/2 x 1/4 x 3	10.3	6.1

♠ DODGE standard belt guards will not fit this motor mount.

† Shaft key furnished.

▲ Check the driven shaft and key for strength.

◆ Preferred bore. No bushing required for this bore size.

○ Stock TXT5 Reducers are drilled for vertical mounting.

♣ Made to order.

■ See page G2-201 for reducer part numbers and drill and tap

dimensions for Flange Mount TXT Reducers. Now available only as special factory order.

● Taper Bushed Reducers require bushing for all bore sizes.

♥ Use with Taper Bushed Reducers only. See page G2-203 for drill and tap information required to mount to reducer.

FEATURES/BENEFITS PAGE G2-3	NOMENCLATURE PAGE G2-11	SELECTION PAGE G2-13	RELATED PRODUCTS PAGE G2-152
--------------------------------	----------------------------	-------------------------	---------------------------------

SELECTION/DIMENSIONS



TORQUE-ARM Shaft Mount Speed Reducers TXT505A - SINGLE REDUCTION TAPER BUSHED

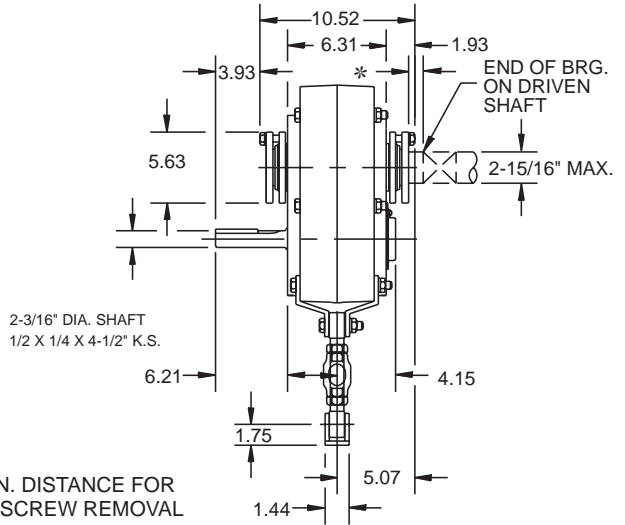
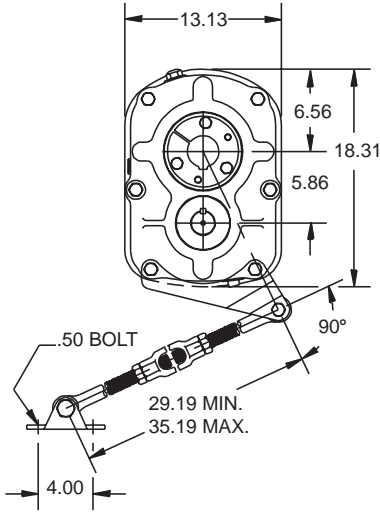

TXT505A - SINGLE REDUCTION STRAIGHT BORE

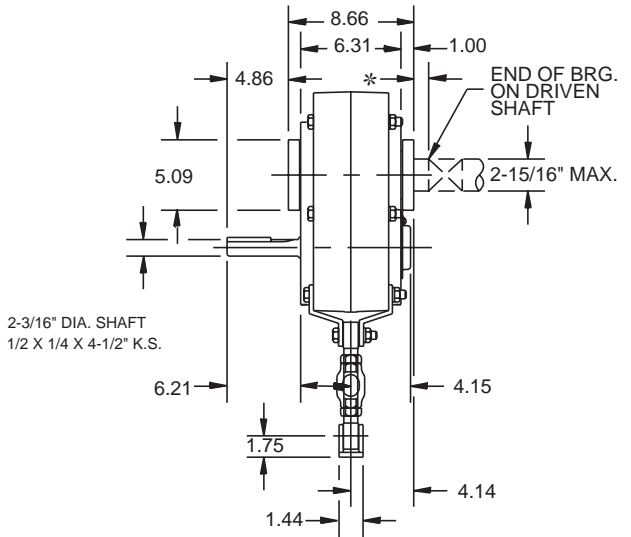
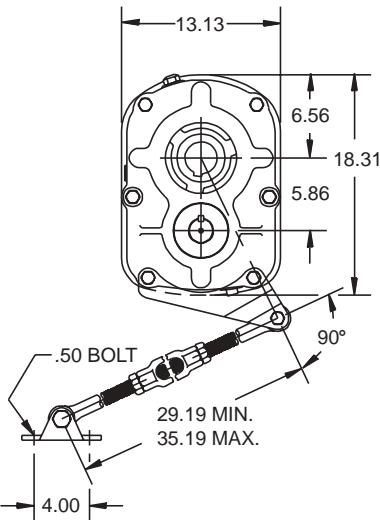

FEATURES/BENEFITS PAGE G2-3	NOMENCLATURE PAGE G2-11	SELECTION PAGE G2-13	RELATED PRODUCTS PAGE G2-152
--------------------------------	----------------------------	-------------------------	---------------------------------

SELECTION/DIMENSIONS



TORQUE-ARM Shaft Mount Speed Reducers

TXT505A Taper Bushed Reducers ■ ○

Reducer Size	Part Number	AGMA Code	Actual Ratio	Weight
TXT505AT	255200	215S05	5.67	182

TXT505A Straight Bore Reducers ■ ○

Reducer Size	Part Number	AGMA Code	Actual Ratio	Weight
TXT505AS	255204	215S05	5.67	182

TXT505A Accessories

Description	Part Number	Weight
TA5M Standard Motor Mount (143T-286T)	245391	76
TA5M Special Motor Mount (324T-326T) ♠	245393	79
TA5ML Long Motor Mount (143T-286T)	245392	89
TAB5 Bottom Motor Mount (143T-326T) ♠	245405	55
TXT505A Backstop Assembly	246101	1.8
Optional Filter Breather (1/2-14 NPT)	430049	.2
TXT5-S TA Reducer Belt Guard (143T-286T)	245389	59
TXT5-S TA Reducer Belt Guard for Long Motor Mount (143T-286T) ♣	245162	90
TXT505A Cooling Fan Assembly	255231	3
TXT505A Taconite Auxiliary Seal Kit ♥	255230	12.3

TXT5 Bushing Assemblies ●

Stock Bore Size		Part Number		Shaft Keyseat Required †		Weight	
		Tapered Bushing	Straight Bore Bushing	Tapered Bushing	Straight Bore Bushing	Tapered Bushing	Straight Bore Bushing
2-15/16	(Max.)	245112	◆	3/4 x 3/8 x 9-3/8	3/4 x 3/8 x 4-3/8	7.8	-
2-11/16		245110	245428	5/8 x 5/16 x 9-3/8	5/8 x 5/16 x 4-3/8	7.9	3
2-1/2	▲	245099	245427	5/8 x 5/16 x 9-3/8	5/8 x 5/16 x 4-3/8	8.5	3.4
2-7/16	▲	245094	245426	5/8 x 5/16 x 9-3/8	5/8 x 5/16 x 4-3/8	8.5	4.3
2-1/4	▲	245092	245425	1/2 x 1/4 x 9-3/8	1/2 x 1/4 x 3	9.2	4.7
2-3/16	▲	245090	245424	1/2 x 1/4 x 9-3/8	1/2 x 1/4 x 3	10	5.6
2	▲	245088	245423	1/2 x 1/4 x 9-3/8	1/2 x 1/4 x 3	10.2	5.9
1-15/16	▲	245086	245422	1/2 x 1/4 x 9-3/8	1/2 x 1/4 x 3	10.3	6.1

♠ DODGE standard belt guards will not fit this motor mount.

† Shaft key furnished.

▲ Check the driven shaft and key for strength.

◆ Preferred bore. No bushing required for this bore size.

○ Stock TXT505 Reducers are drilled for vertical mounting.

♣ Made to order.

■ See page G2-201 for reducer part numbers and drill and tap dimensions. for Flange Mount TXT Reducers. Now available only as special factory order.

● Taper Bushed Reducers require bushing for all bore sizes.

♥ Use with Taper Bushed Reducer only. See page G2-203 for drill and tap information required to mount to reducer.

FEATURES/BENEFITS PAGE G2-3	NOMENCLATURE PAGE G2-11	SELECTION PAGE G2-13	RELATED PRODUCTS PAGE G2-152
--------------------------------	----------------------------	-------------------------	---------------------------------

SELECTION/DIMENSIONS



TORQUE-ARM Shaft Mount Speed Reducers TXT6 - DOUBLE REDUCTION TAPER BUSHED

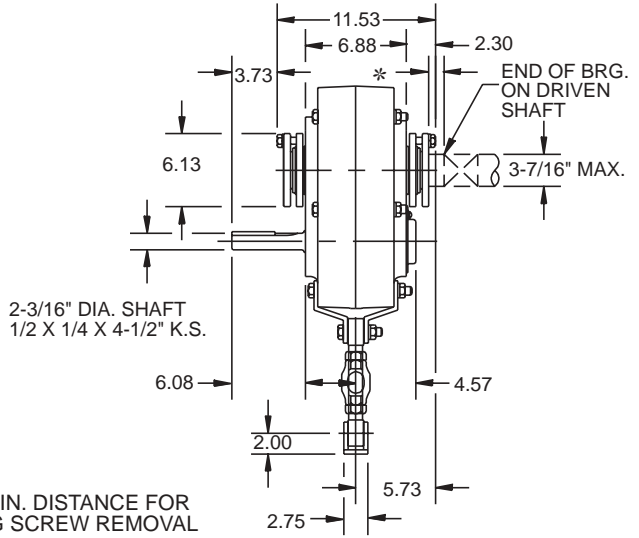
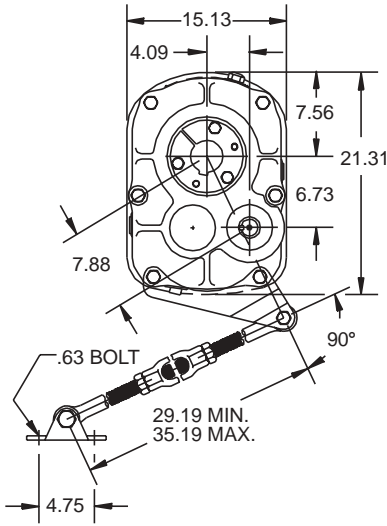

TXT6 - DOUBLE REDUCTION STRAIGHT BORE

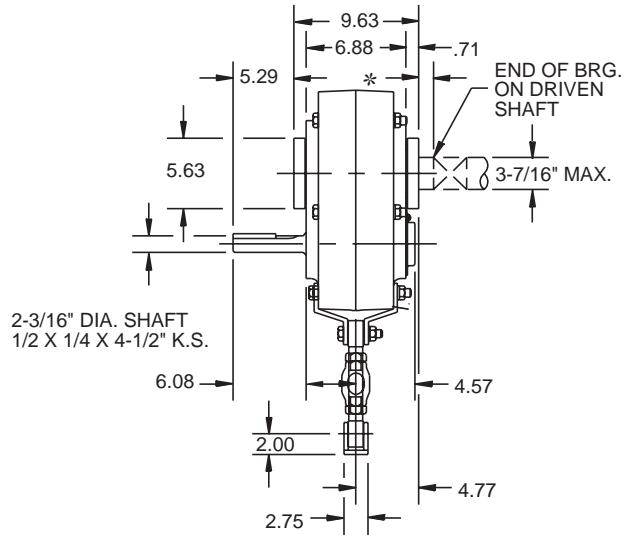
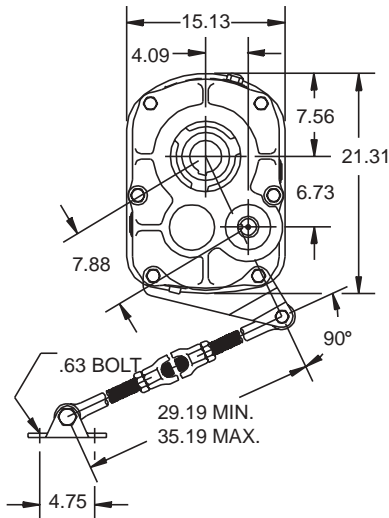

FEATURES/BENEFITS
PAGE G2-3

NOMENCLATURE
PAGE G2-11

SELECTION
PAGE G2-13

RELATED PRODUCTS
PAGE G2-152



TORQUE-ARM Shaft Mount Speed Reducers

TXT6 Taper Bushed Reducers ■ ○

Reducer Size	Part Number	AGMA Code	Actual Ratio	Weight
TXT609T	246149 ♣	307D09	9.20	285
TXT615T	246150	307D15	15.33	285
TXT625T	246151	307D25	25.13	285

TXT6 Straight Bore Reducers ■ ○

Reducer Size	Part Number	AGMA Code	Actual Ratio	Weight
TXT609S	246327 ♣	307D09	9.20	285
TXT615S	246158	307D15	15.33	285
TXT625S	246159	307D25	25.13	285

TXT6 Accessories

Description	Part Number	Weight
TA6M Standard Motor Mount (143T-326T)	246391	99
TA6M Special Motor Mount (364T) ♣ ♣	246388	110
TA6ML Long Motor Mount (143T-326T)	246390	100
TAB6 Bottom Motor Mount (182T-326T) ♣	246392	84
TXT6 Backstop Assembly	246092	2.5
Optional Filter Breather (1/2-14 NPT)	430049	0.2
TXT6-D TA Reducer Belt Guard (143T-326T)	246366	83
TXT6-D TA Reducer Belt Guard for Long Motor Mount (143T-326T)	246147	100
TXT6 Cooling Fan Assembly	272325	3
TXT6 Taconite Auxiliary Seal Kit ♥	272450	17.7

TXT6 Bushing Assemblies ●

Stock Bore Size		Part Number		Shaft Keyseat Required †		Weight	
		Tapered Bushing	Straight Bore Bushing	Tapered Bushing	Straight Bore Bushing	Tapered Bushing	Straight Bore Bushing
3-7/16	(Max.)	246268	◆	7/8 x 7/16 x 10-11/16	7/8 x 7/16 x 5-7/8	9	-
3	▲	246283	246427	3/4 x 3/8 x 10-11/16	3/4 x 3/8 x 5-7/8	11.3	4.6
2-15/16	▲	246267	246426	3/4 x 3/8 x 10-11/16	3/4 x 3/8 x 5-7/8	11.6	6.7
2-7/8	▲	246266	246425	3/4 x 3/8 x 10-11/16	3/4 x 3/8 x 5-7/8	12.2	6.7
2-11/16	▲	246265	246424	5/8 x 5/16 x 10-11/16	5/8 x 5/16 x 5-7/8	12.9	6.7
2-1/2	▲	246264	246423	5/8 x 5/16 x 10-11/16	5/8 x 5/16 x 3-1/2	14	8.2
2-7/16	▲	246263	246422	5/8 x 5/16 x 10-11/16	5/8 x 5/16 x 3-1/2	14.4	8.5
2-1/4	▲	246262	246421	1/2 x 1/4 x 10-11/16	1/2 x 1/4 x 3-1/2	14.9	9.8
2-3/16	▲	246261	246420	1/2 x 1/4 x 10-11/16	1/2 x 1/4 x 3-1/2	15.3	11

♣ DODGE standard belt guards will not fit this motor mount.

† Shaft key furnished.

▲ Check the driven shaft and key for strength.

◆ Preferred bore. No bushing required for this bore size.

○ Stock TXT6 Reducers are drilled for vertical mounting.

♣ Made to order.

■ See page G2-201 for reducer part numbers and drill and tap dimensions. for Flange Mount TXT Reducers. Now available only as special factory order.

● Taper Bushed Reducers require bushing for all bore sizes.

♥ Use with Taper Bushed Reducer only. See page G2-203 for drill and tap information required to mount to reducer.

FEATURES/BENEFITS PAGE G2-3	NOMENCLATURE PAGE G2-11	SELECTION PAGE G2-13	RELATED PRODUCTS PAGE G2-152
--------------------------------	----------------------------	-------------------------	---------------------------------

SELECTION/DIMENSIONS



TORQUE-ARM Shaft Mount Speed Reducers TXT605 - SINGLE REDUCTION TAPER BUSHED

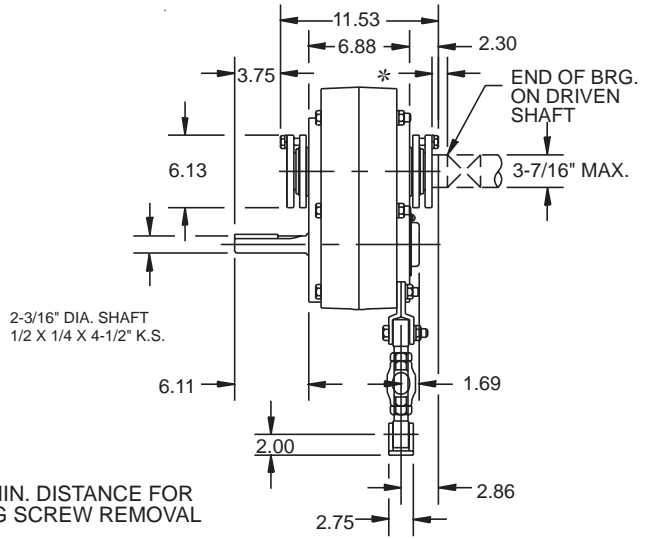
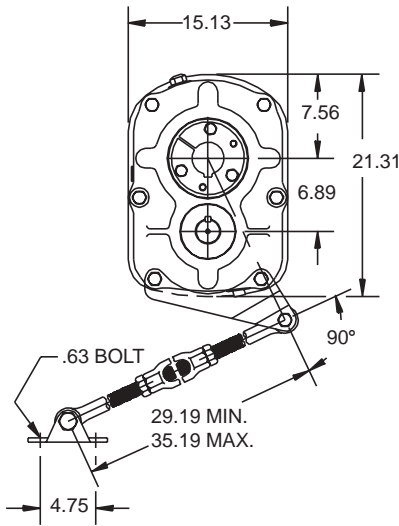

TXT605 - SINGLE REDUCTION STRAIGHT BORE

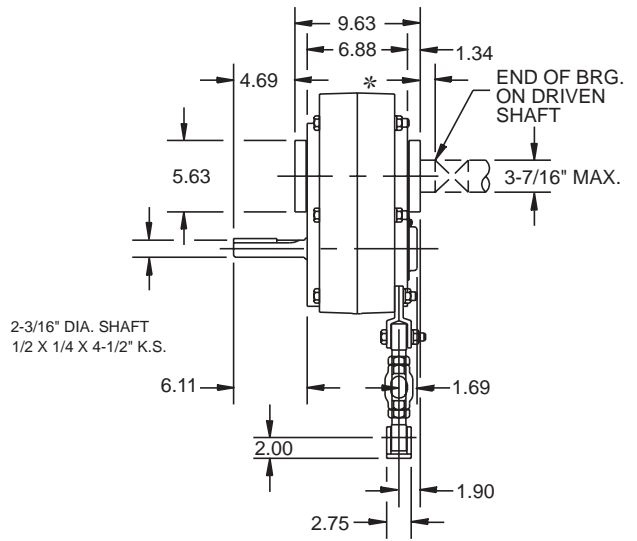
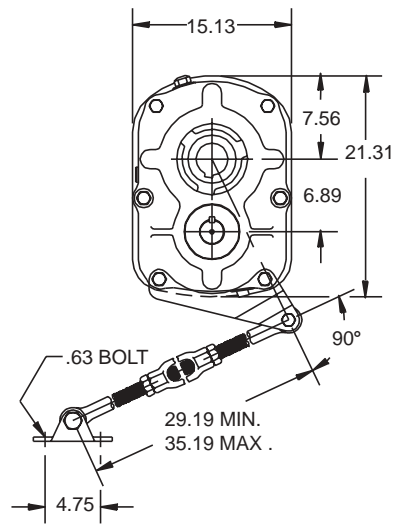

FEATURES/BENEFITS PAGE G2-3	NOMENCLATURE PAGE G2-11	SELECTION PAGE G2-13	RELATED PRODUCTS PAGE G2-152
--------------------------------	----------------------------	-------------------------	---------------------------------



TORQUE-ARM Shaft Mount Speed Reducers

TXT605 Taper Bushed Reducers ■ ○

Reducer Size	Part Number	AGMA Code	Actual Ratio	Weight
TXT605T	246380	307S05	5.67	251

TXT605 Straight Bore Reducers ■ ○

Reducer Size	Part Number	AGMA Code	Actual Ratio	Weight
TXT605S	246382	307S05	5.67	251

TXT605 Accessories

Description	Part Number	Weight
TA6M Standard Motor Mount (143T-326T)	246391	99
TA6ML Long Motor Mount (143T-326T)	246390	100
TAB6 Bottom Motor Mount (182T-326T) †	246392	84
TXT605 Backstop Assembly	246092	2.5
Optional Filter Breather (1/2-14 NPT)	430049	0.2
TXT6-S TA Reducer Belt Guard (143T-326T)	246368	95
TXT6-S TA Reducer Belt Guard for Long Motor Mount (143T-326T) †	246132	100
TXT605 Cooling Fan Assembly †	272681	3
TXT605 Taconite Auxiliary Seal Kit ♥	272450	17.7

TXT6 Bushing Assemblies ●

Stock Bore Size	Part Number		Shaft Keyseat Required †		Weight	
	Tapered Bushing	Straight Bore Bushing	Tapered Bushing	Straight Bore Bushing	Tapered Bushing	Straight Bore Bushing
3-7/16 (Max.)	246268	◆	7/8 x 7/16 x 10-11/16	7/8 x 7/16 x 5-7/8	9	-
3 ▲	246283	246427	3/4 x 3/8 x 10-11/16	3/4 x 3/8 x 5-7/8	11.30	4.6
2-15/16 ▲	246267	246426	3/4 x 3/8 x 10-11/16	3/4 x 3/8 x 5-7/8	11.60	6.7
2-7/8 ▲	246266	246425	3/4 x 3/8 x 10-11/16	3/4 x 3/8 x 5-7/8	12.20	6.7
2-11/16 ▲	246265	246424	5/8 x 5/16 x 10-11/16	5/8 x 5/16 x 5-7/8	12.90	6.7
2-1/2 ▲	246264	246423	5/8 x 5/16 x 10-11/16	5/8 x 5/16 x 3-1/2	14	8.2
2-7/16 ▲	246263	246422	5/8 x 5/16 x 10-11/16	5/8 x 5/16 x 3-1/2	14.40	8.5
2-1/4 ▲	246262	246421	1/2 x 1/4 x 10-11/16	1/2 x 1/4 x 3-1/2	14.90	9.8
2-3/16 ▲	246261	246420	1/2 x 1/4 x 10-11/16	1/2 x 1/4 x 3-1/2	15.30	11

† DODGE standard belt guards will not fit this motor mount.

† Shaft key furnished.

▲ Check the driven shaft and key for strength.

◆ Preferred bore. No bushing required for this bore size.

○ Stock TXT605 Reducers are drilled for vertical mounting.

♣ Made to order.

■ See page G2-201 for reducer part numbers and drill and tap dimensions. for Flange Mount TXT Reducers. Now available only as special factory order.

● Taper Bushed Reducers require bushing for all bore sizes.

♥ Use with Taper Bushed Reducder only. See page G2-203 for drill and tap information required to mount to reducer.

FEATURES/BENEFITS PAGE G2-3	NOMENCLATURE PAGE G2-11	SELECTION PAGE G2-13	RELATED PRODUCTS PAGE G2-152
--------------------------------	----------------------------	-------------------------	---------------------------------

SELECTION/DIMENSIONS



TORQUE-ARM Shaft Mount Speed Reducers TXT7 - DOUBLE REDUCTION TAPER BUSHED

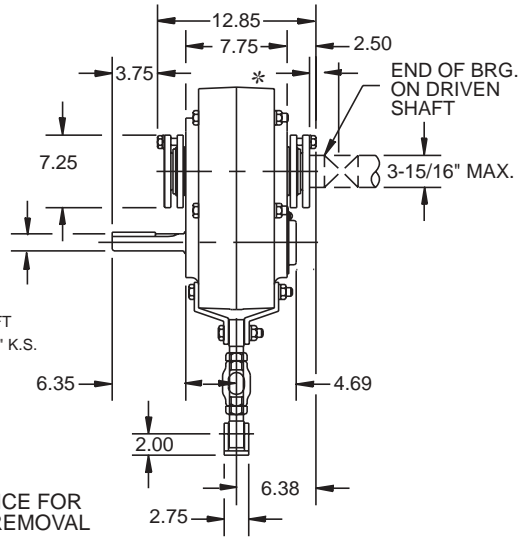
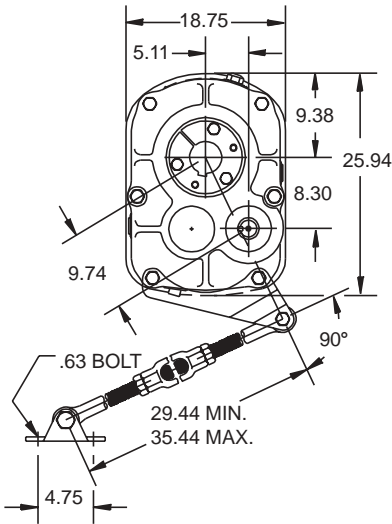

TXT7 - DOUBLE REDUCTION STRAIGHT BORE

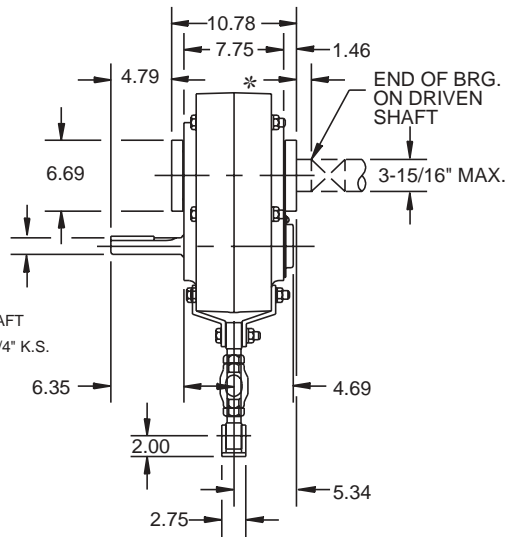
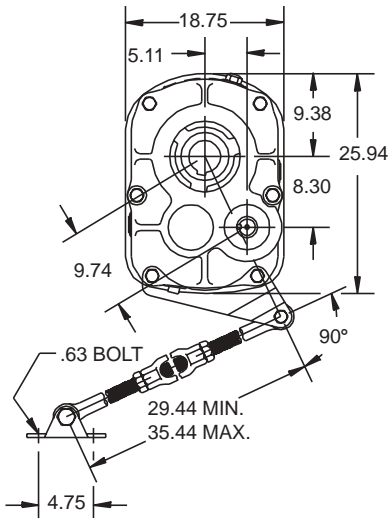

FEATURES/BENEFITS PAGE G2-3	NOMENCLATURE PAGE G2-11	SELECTION PAGE G2-13	RELATED PRODUCTS PAGE G2-152
--------------------------------	----------------------------	-------------------------	---------------------------------

SELECTION/DIMENSIONS



TORQUE-ARM Shaft Mount Speed Reducers

TXT7 Taper Bushed Reducers ■ ○

Reducer Size	Part Number	AGMA Code	Actual Ratio	Weight
TXT709T	247159 ♣	315D09	9.61	462
TXT715T	247160	315D15	15.23	462
TXT725T	247161	315D25	24.59	462

TXT7 Straight Bore Reducers ■ ○

Reducer Size	Part Number	AGMA Code	Actual Ratio	Weight
TXT709S	247327 ♣	315D09	9.61	462
TXT715S	247168	315D15	15.23	462
TXT725S	247169	315D25	24.59	462

TXT7 Accessories

Description	Part Number	Weight
TA7M Standard Motor Mount (143T-365T)	247395	110
TA7ML Long Motor Mount (143T-326T)	247396	100
TAB7 Bottom Motor Mount (182T-326T) ♣	247404	105
TXT7 Backstop Assembly	247260	2.8
Optional Filter Breather (1/2-14 NPT)	430049	.2
TXT7-D TA Reducer Belt Guard (143T-365T)	247390	90
TXT7-D TA Reducer Belt Guard for Long Motor Mount (143T-365T) ♣	247152	108
TXT7 Cooling Fan Assembly	272326	6
TXT7 Taconite Auxiliary Seal Kit ♥	272451	25

TXT7 Bushing Assemblies ●

Stock Bore Size	Part Number		Shaft Keyseat Required †		Weight	
	Tapered Bushing	Straight Bore Bushing	Tapered Bushing	Straight Bore Bushing	Tapered Bushing	Straight Bore Bushing
3-15/16 (Max.)	272136	◆	1 x 1/2 x 11-27/32	1 x 1/2 x 4-7/8	13.8	-
3-7/16	272135	247428	7/8 x 7/16 x 11-27/32	7/8 x 7/16 x 6-3/8	16.9	7.8
3-3/16 ▲	272134	247427	3/4 x 3/8 x 11-27/32	3/4 x 3/8 x 6-3/8	19.2	9
3 ▲	272133	247426	3/4 x 3/8 x 11-27/32	3/4 x 3/8 x 6-3/8	20.1	10.1
2-15/16 ▲	272132	247425	3/4 x 3/8 x 11-27/32	3/4 x 3/8 x 4-7/8	21.3	10.1
2-11/16 ▲	272147	247422	5/8 x 5/16 x 11-27/32	5/8 x 5/16 x 3-1/2	23	14
2-7/16 ▲	272125	247420	5/8 x 5/16 x 11-27/32	5/8 x 5/16 x 3-1/2	24.2	14.2

♣ DODGE standard belt guards will not fit this motor mount.

† Shaft key furnished.

▲ Check the driven shaft and key for strength.

◆ Preferred bore. No bushing required for this bore size.

○ Stock TXT7 Reducers are drilled for vertical mounting.

♣ Made to order.

■ See page G2-201 for reducer part numbers and drill and tap dimensions. For Flange Mount TXT Reducers. Now available only as special factory order.

● Taper Bushed Reducers require bushing for all bore sizes.

♥ Use with Taper Bushed Redudcer only. See page G2-203 for drill and tap information required to mount to reducer.

FEATURES/BENEFITS PAGE G2-3	NOMENCLATURE PAGE G2-11	SELECTION PAGE G2-13	RELATED PRODUCTS PAGE G2-152
--------------------------------	----------------------------	-------------------------	---------------------------------

SELECTION/DIMENSIONS



TORQUE-ARM Shaft Mount Speed Reducers TXT705 - SINGLE REDUCTION TAPER BUSHED

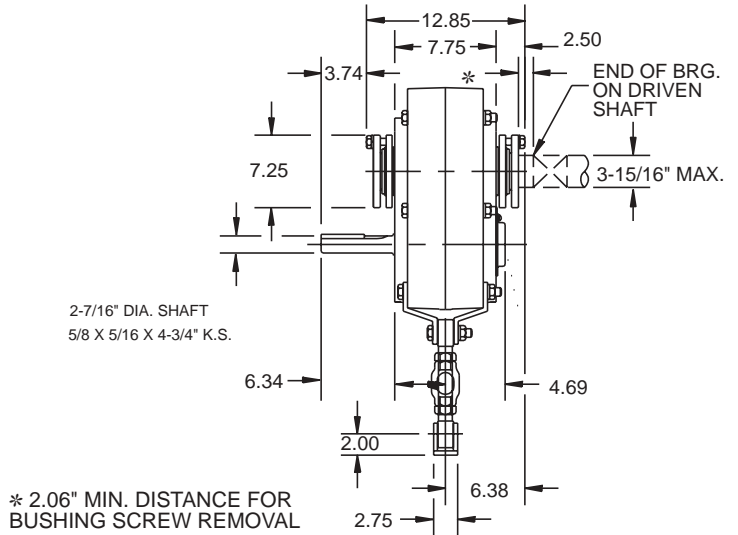
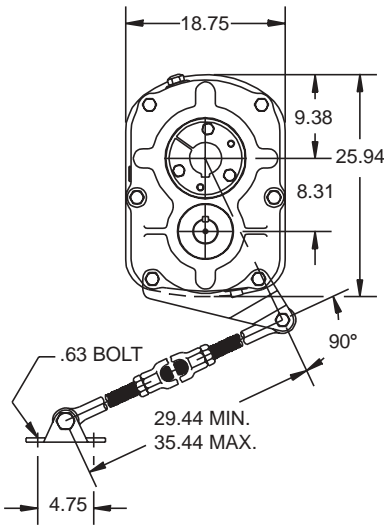

TXT705 - SINGLE REDUCTION STRAIGHT BORE

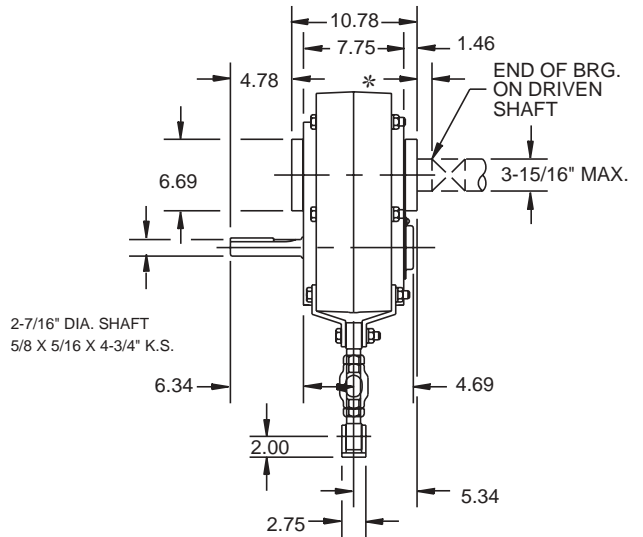
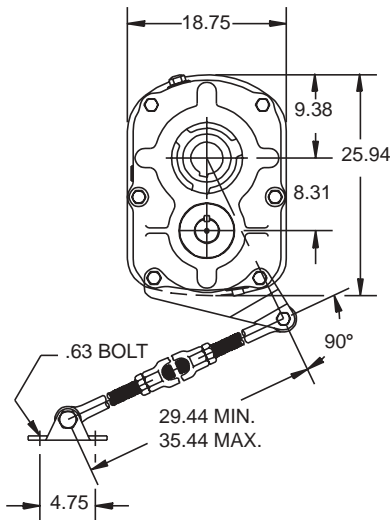

FEATURES/BENEFITS PAGE G2-3	NOMENCLATURE PAGE G2-11	SELECTION PAGE G2-13	RELATED PRODUCTS PAGE G2-152
--------------------------------	----------------------------	-------------------------	---------------------------------

SELECTION/DIMENSIONS



TORQUE-ARM Shaft Mount Speed Reducers

TXT705 Taper Bushed Reducers ■ ○

Reducer Size	Part Number	AGMA Code	Actual Ratio	Weight
TXT705T	247285	315S05	5.36	410

TXT705 Straight Bore Reducers ■ ○

Reducer Size	Part Number	AGMA Code	Actual Ratio	Weight
TXT705S	247287	315S05	5.36	410

TXT705 Accessories

Description	Part Number	Weight
TA7M Standard Motor Mount (143T-365T)	247395	110
TA7ML Long Motor Mount (143T-326T)	247396	100
TAB7 Bottom Motor Mount (182T-326T) ♣	247404	105
TXT705 Backstop Assembly	247260	2.80
Optional Filter Breather (1/2-14 NPT)	430049	0.20
TXT7-S TA Reducer Belt Guard (143T-365T)	247392	112
TXT7-S TA Reducer Belt Guard for Long Motor Mount (143T-365T) ♣	247146	135
TXT705 Cooling Fan Assembly ♣	272685	6
TXT705 Taconite Auxilliary Seal Kit ♥	272451	25

TXT7 Bushing Assemblies ●

Stock Bore Size	Part Number		Shaft Keyseat Required †		Weight	
	Tapered Bushing	Straight Bore Bushing	Tapered Bushing	Straight Bore Bushing	Tapered Bushing	Straight Bore Bushing
3-15/16 (Max.)	272136	◆	1 x 1/2 x 11-27/32	1 x 1/2 x 4-7/8	13.8	-
3-7/16	272135	247428	7/8 x 7/16 x 11-27/32	7/8 x 7/16 x 6-3/8	16.9	7.8
3-3/16 ▲	272134	247427	3/4 x 3/8 x 11-27/32	3/4 x 3/8 x 6-3/8	19.2	9
3 ▲	272133	247426	3/4 x 3/8 x 11-27/32	3/4 x 3/8 x 6-3/8	20.1	10.1
2-15/16 ▲	272132	247425	3/4 x 3/8 x 11-27/32	3/4 x 3/8 x 4-7/8	21.3	10.1
2-11/16 ▲	272147	247422	5/8 x 5/16 x 11-27/32	5/8 x 5/16 x 3-1/2	23	14
2-7/16 ▲	272125	247420	5/8 x 5/16 x 11-27/32	5/8 x 5/16 x 3-1/2	24.2	14.2

♣ DODGE standard belt guards will not fit this motor mount.

† Shaft key furnished.

▲ Check the driven shaft and key for strength.

◆ Preferred bore. No bushing required for this bore size.

○ Stock TXT705 Reducers are drilled for vertical mounting.

♣ Made to order.

■ See page G2-201 for reducer part numbers and drill and tap dimensions. for Flange Mount TXT Reducers. Now available only as special factory order.

● Taper Bushed Reducers require bushing for all bore sizes.

♥ Use with Taper Bushed Reducder only. See page G2-203 for drill and tap information required to mount to reducer.

FEATURES/BENEFITS PAGE G2-3	NOMENCLATURE PAGE G2-11	SELECTION PAGE G2-13	RELATED PRODUCTS PAGE G2-152
--------------------------------	----------------------------	-------------------------	---------------------------------

SELECTION/DIMENSIONS



TORQUE-ARM Shaft Mount Speed Reducers TXT8 - DOUBLE REDUCTION TAPER BUSHED

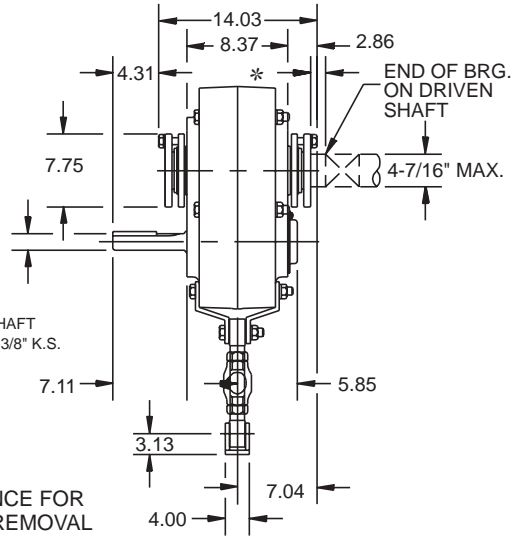
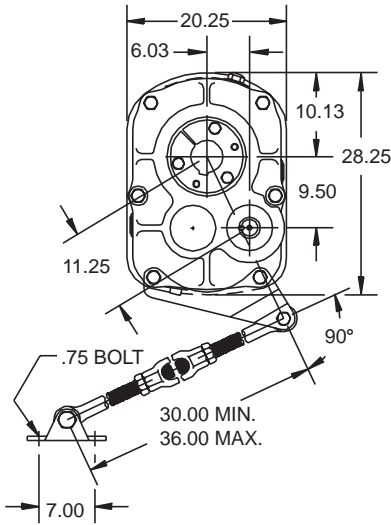

* 2.06" MIN. DISTANCE FOR BUSHING SCREW REMOVAL

TXT8 - DOUBLE REDUCTION STRAIGHT BORE

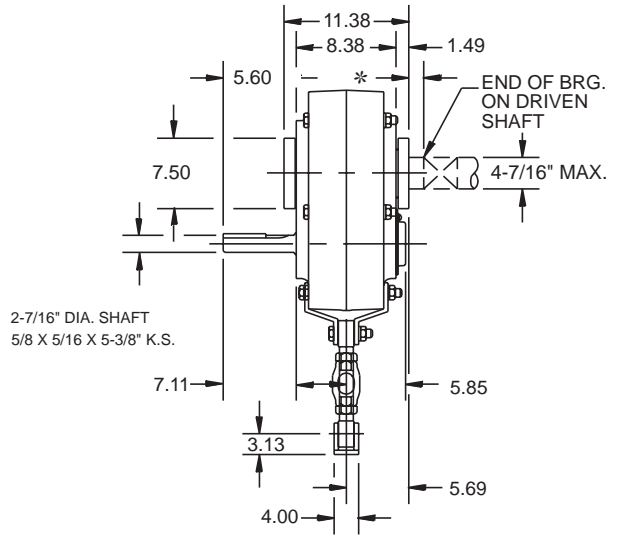
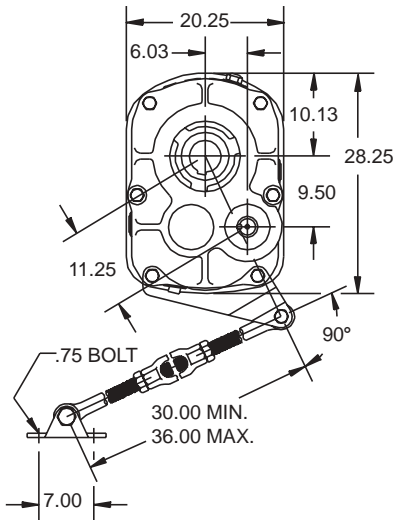

FEATURES/BENEFITS PAGE G2-3	NOMENCLATURE PAGE G2-11	SELECTION PAGE G2-13	RELATED PRODUCTS PAGE G2-152
--------------------------------	----------------------------	-------------------------	---------------------------------

SELECTION/DIMENSIONS



TORQUE-ARM Shaft Mount Speed Reducers

TXT8 Taper Bushed Reducers ■ ○

Reducer Size	Part Number	AGMA Code	Actual Ratio	Weight
TXT815T	248279	407D15	15.08	633
TXT825T	248280	407D25	24.62	633

TXT8 Straight Bore Reducers ■ ○

Reducer Size	Part Number	AGMA Code	Actual Ratio	Weight
TXT815S	248283	407D15	15.08	633
TXT825S	248284	407D25	24.62	633

TXT8 Bushing Assemblies ●

Stock Bore Size	Part Number		Shaft Keyseat Required †		Weight	
	Tapered Bushing	Straight Bore Bushing	Tapered Bushing	Straight Bore Bushing	Tapered Bushing	Straight Bore Bushing
4-7/16 (Max.)	272035	◆	1 x 1/2 x 13-1/16	1 x 1/2 x 6-7/8	15	-
4-3/16	272034	248424	1 x 1/2 x 13-1/16	1 x 1/2 x 6-7/8	17	6.8
3-15/16	272033	248423	1 x 1/2 x 13-1/16	1 x 1/2 x 6-7/8	20	8
3-7/16 ▲	272032	248422	7/8 x 7/16 x 13-1/16	7/8 x 7/16 x 6-7/8	25	12
2-15/16 ▲	272048	248420	3/4 x 3/8 x 13-1/16	3/4 x 3/8 x 4-3/8	29	19

♣ DODGE standard belt guards will not fit this motor mount.

† Shaft key furnished.

▲ Check the driven shaft and key for strength.

◆ Preferred bore. No bushing required for this bore size.

○ Stock TXT8 Reducers are drilled for vertical mounting.

♣ Made to order.

TXT8 Accessories

Description	Part Number	Weight
TA8 Standard Motor Mount (213T-365T)	248401	119
TAB8 Bottom Motor Mount (213T-365T) ♣	248406	120
TXT8 Backstop Assembly	249260	3.8
Optional Filter Breather (1/2-14 NPT)	430049	.2
TXT8-D TA Reducer Belt Guard (213T-365T)	248395	107
TXT8 Cooling Fan Assembly	272327	9
TXT8 Taconite Auxiliary Seal Kit ♥	272452	26.3

■ See page G2-201 for reducer part numbers and drill and tap dimensions. for Flange Mount TXT Reducers. Now available only as special factory order.

● Taper Bushed Reducers require bushing for all bore sizes.

♥ Use with Taper Bushed Redudcer only. See page G2-203 for drill and tap information required to mount to reducer.

FEATURES/BENEFITS PAGE G2-3	NOMENCLATURE PAGE G2-11	SELECTION PAGE G2-13	RELATED PRODUCTS PAGE G2-152
--------------------------------	----------------------------	-------------------------	---------------------------------

SELECTION/DIMENSIONS



TORQUE-ARM Shaft Mount Speed Reducers TXT805 - SINGLE REDUCTION TAPER BUSHED

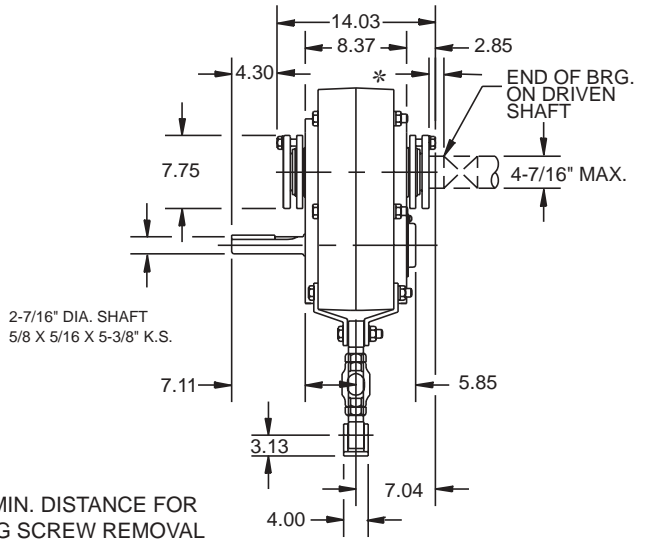
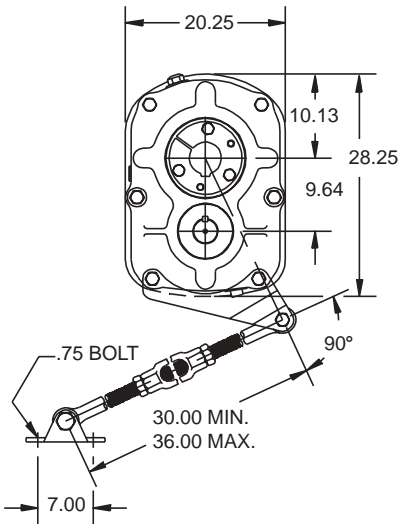

TXT805 - SINGLE REDUCTION STRAIGHT BORE

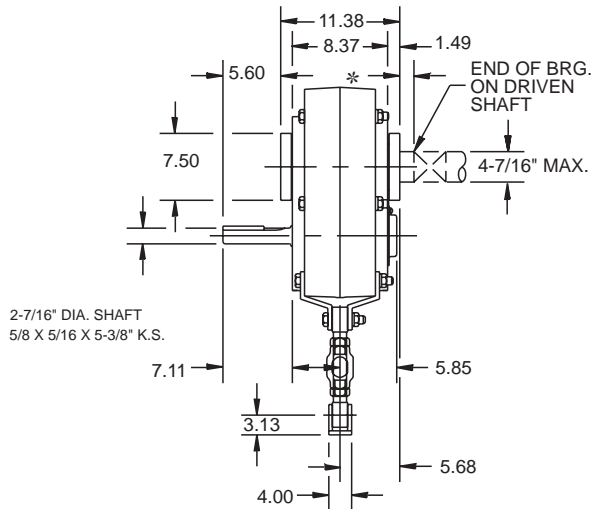
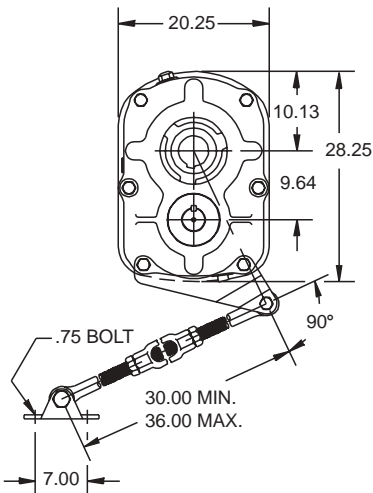

FEATURES/BENEFITS PAGE G2-3	NOMENCLATURE PAGE G2-11	SELECTION PAGE G2-13	RELATED PRODUCTS PAGE G2-152
--------------------------------	----------------------------	-------------------------	---------------------------------

SELECTION/DIMENSIONS



TORQUE-ARM Shaft Mount Speed Reducers

TXT805 Taper Bushed Reducers ■ ○

Reducer Size	Part Number	AGMA Code	Actual Ratio	Weight
TXT805T	248275	407S05	5.50	557

TXT805 Straight Bore Reducers ■ ○

Reducer Size	Part Number	AGMA Code	Actual Ratio	Weight
TXT805S	248277	407S05	5.50	557

TXT805 Accessories

Description	Part Number	Weight
TA8 Standard Motor Mount (254T-365T)	248401	119
TAB8 Bottom Motor Mount (213T-365T) †	248406	120
TXT805 Backstop Assembly	250260	5.6
Optional Filter Breather (1/2-14 NPT)	430049	.2
TXT8-S TA Reducer Belt Guard (213T-365T)	248397	125
TXT8 Cooling Fan Assembly	272327	9
TXT8 Taconite Auxiliary Seal Kit ♥	272452	26.3

TXT8 Bushing Assemblies ●

Stock Bore Size	Part Number		Shaft Keyseat Required †		Weight	
	Tapered Bushing	Straight Bore Bushing	Tapered Bushing	Straight Bore Bushing	Tapered Bushing	Straight Bore Bushing
4-7/16 (Max.)	272035	◆	1 x 1/2 x 13-1/16	1 x 1/2 x 6-7/8	15	-
4-3/16	272034	248424	1 x 1/2 x 13-1/16	1 x 1/2 x 6-7/8	17	6.80
3-15/16	272033	248423	1 x 1/2 x 13-1/16	1 x 1/2 x 6-7/8	20	8
3-7/16 ▲	272032	248422	7/8 x 7/16 x 13-1/16	7/8 x 7/16 x 6-7/8	25	12
2-15/16 ▲	272048	248420	3/4 x 3/8 x 13-1/16	3/4 x 3/8 x 4-3/8	29	19

‡ DODGE standard belt guards will not fit this motor mount.

† Shaft key furnished.

▲ Check the driven shaft and key for strength.

◆ Preferred bore. No bushing required for this bore size.

○ Stock TXT805 Reducers are drilled for vertical mounting.

♣ Made to order.

■ See page G2-201 for reducer part numbers and drill and tap dimensions. For Flange Mount TXT Reducers. Now available only as special factory order.

● Taper Bushed Reducers require bushing for all bore sizes.

♥ Use with Taper Bushed Reducer only. See page G2-203 for drill and tap information required to mount to reducer.

FEATURES/BENEFITS PAGE G2-3	NOMENCLATURE PAGE G2-11	SELECTION PAGE G2-13	RELATED PRODUCTS PAGE G2-152
--------------------------------	----------------------------	-------------------------	---------------------------------

SELECTION/DIMENSIONS



TORQUE-ARM Shaft Mount Speed Reducers TXT9 - DOUBLE REDUCTION TAPER BUSHED

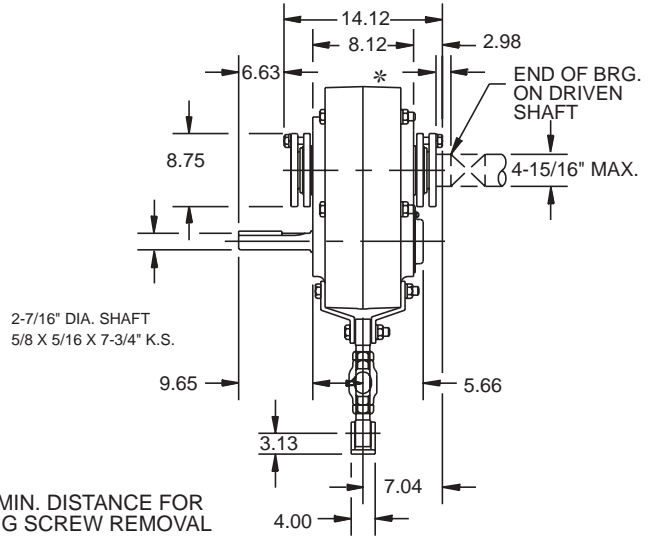
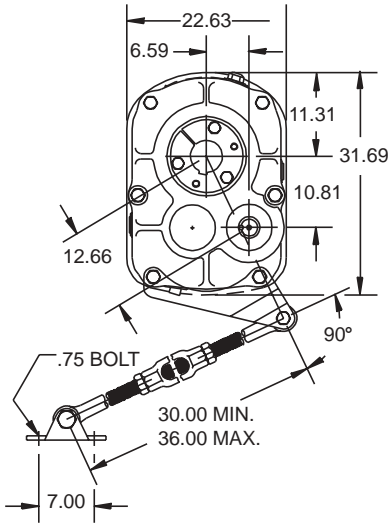

TXT9 - DOUBLE REDUCTION STRAIGHT BORE

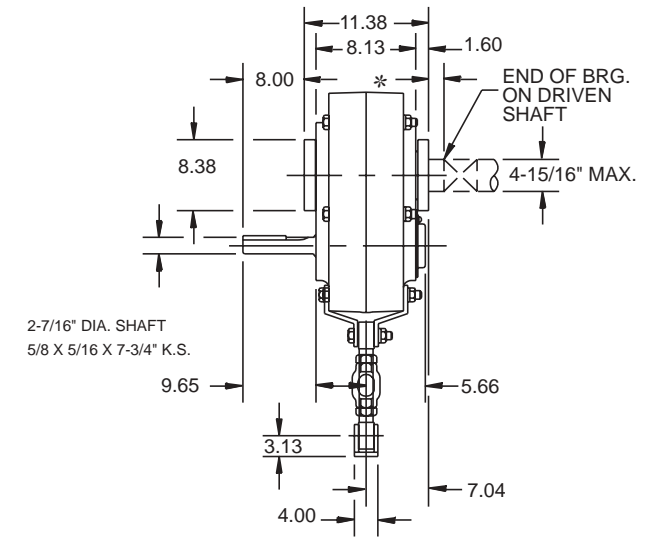
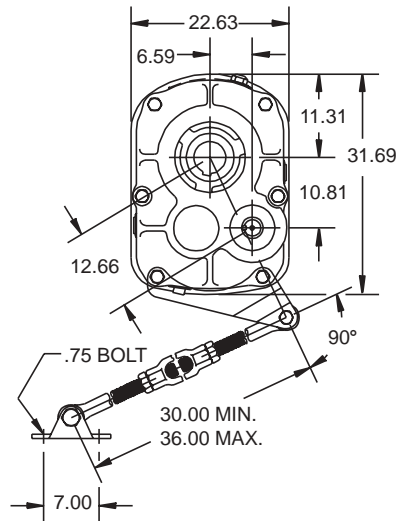

FEATURES/BENEFITS PAGE G2-3	NOMENCLATURE PAGE G2-11	SELECTION PAGE G2-13	RELATED PRODUCTS PAGE G2-152
--------------------------------	----------------------------	-------------------------	---------------------------------

SELECTION/DIMENSIONS



TORQUE-ARM Shaft Mount Speed Reducers

TXT9 Taper Bushed Reducers ■ ○

Reducer Size	Part Number	AGMA Code	Actual Ratio	Weight
TXT915T	249269	415D15	15.12	760
TXT926T	249270	415D26	25.66	760

TXT9 Straight Bore Reducers ■ ○

Reducer Size	Part Number	AGMA Code	Actual Ratio	Weight
TXT915S	249273	415D15	15.12	760
TXT926S	249274	415D26	25.66	760

TXT9 Accessories

Description	Part Number	Weight
TA9 Standard Motor Mount (213T-365T)	249401	120
TA9 Special Motor Mount (404T-405T) ♣ ♠	249399	125
TAB9 Bottom Motor Mount (213T-365T) ♠	249404	125
TXT9 Backstop Assembly	249260	3.8
Optional Filter Breather (1/2-14 NPT)	430049	.2
TXT9-D TA Reducer Belt Guard (213T-365T)	249395	125
TXT9 Cooling Fan Assembly	272328	15
TXT9 Taconite Auxiliary Seal Kit ♥	272453	32.6

TXT9 Bushing Assemblies ●

Stock Bore Size	Part Number		Shaft Keyseat Required †		Weight	
	Tapered Bushing	Straight Bore Bushing	Tapered Bushing	Straight Bore Bushing	Tapered Bushing	Straight Bore Bushing
4-15/16 (Max.)	272080	◆	1-1/4 x 5/8 x 12-15/16	1-1/4 x 5/8 x 11-3/8	22	-
4-7/16	272079	249422	1 x 1/2 x 12-15/16	1 x 1/2 x 11-3/8	27	12.5
3-15/16 ▲	272077	249421	1 x 1/2 x 12-15/16	1 x 1/2 x 11-3/8	32.4	26
3-7/16 ▲	272056	249420	7/8 x 7/16 x 12-15/16	7/8 x 7/16 x 5	36	28

♠ DODGE standard belt guards will not fit this motor mount.

† Shaft key furnished.

▲ Check the driven shaft and key for strength.

◆ Preferred bore. No bushing required for this bore size.

○ Stock TXT9 Reducers are drilled for vertical mounting.

♣ Made to order.

■ See page G2-201 for reducer part numbers and drill and tap dimensions. for Flange Mount TXT Reducers. Now available only as special factory order.

● Taper Bushed Reducers require bushing for all bore sizes.

♥ Use with Taper Bushed Reducers only. See page G2-203 for drill and tap information required to mount to reducer.

FEATURES/BENEFITS PAGE G2-3	NOMENCLATURE PAGE G2-11	SELECTION PAGE G2-13	RELATED PRODUCTS PAGE G2-152
--------------------------------	----------------------------	-------------------------	---------------------------------

SELECTION/DIMENSIONS



TORQUE-ARM Shaft Mount Speed Reducers TXT905 - SINGLE REDUCTION TAPER BUSHED

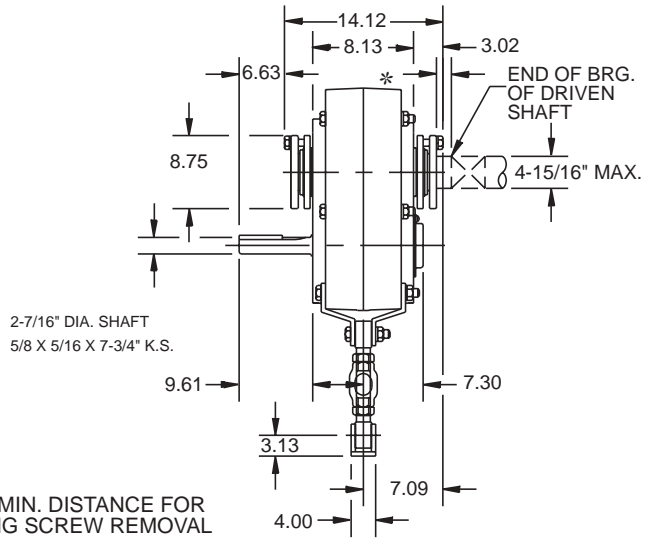
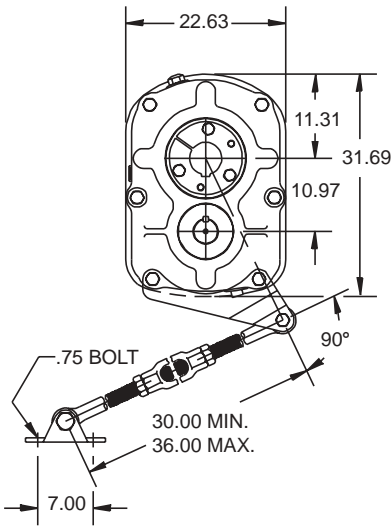

TXT905 - SINGLE REDUCTION STRAIGHT BORE

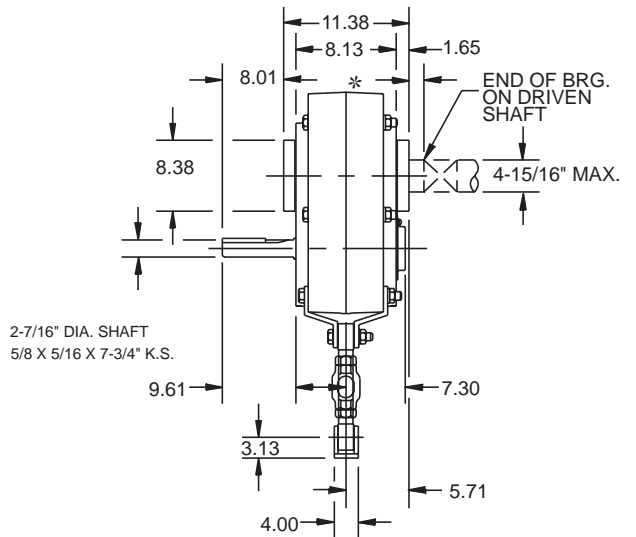
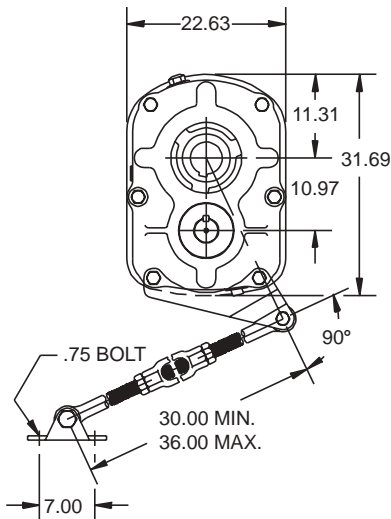

FEATURES/BENEFITS PAGE G2-3	NOMENCLATURE PAGE G2-11	SELECTION PAGE G2-13	RELATED PRODUCTS PAGE G2-152
--------------------------------	----------------------------	-------------------------	---------------------------------

SELECTION/DIMENSIONS



TORQUE-ARM Shaft Mount Speed Reducers

TXT905 Taper Bushed Reducers ■ ○

Reducer Size	Part Number	AGMA Code	Actual Ratio	Weight
TXT905T	249265	415S05	5.38	668

TXT905 Straight Bore Reducers ■ ○

Reducer Size	Part Number	AGMA Code	Actual Ratio	Weight
TXT905S	249267	415S05	5.38	668

TXT905 Accessories

Description	Part Number	Weight
TA9 Standard Motor Mount (284T-365T)	249401	120
TA9 Special Motor Mount (404T-445T) ♣ ♠	249399	125
TAB9 Bottom Motor Mount (213T-365T) ♠	249404	125
TXT905 Backstop Assembly	272259	6.7
Optional Filter Breather (1/2-14 NPT)	430049	.2
TXT9-S TA Reducer Belt Guard (213T-365T)	249397	156
TXT905 Cooling Fan Assembly ♣	272324	15
TXT9 Taconite Auxiliary Seal Kit ♥	272453	32.6

TXT9 Bushing Assemblies ●

Stock Bore Size	Part Number		Shaft Keyseat Required †		Weight	
	Tapered Bushing	Straight Bore Bushing	Tapered Bushing	Straight Bore Bushing	Tapered Bushing	Straight Bore Bushing
4-15/16 (Max.)	272080	◆	1-1/4 x 5/8 x 12-15/16	1-1/4 x 5/8 x 11-3/8	22	-
4-7/16	272079	249422	1 x 1/2 x 12-15/16	1 x 1/2 x 11-3/8	27	12.5
3-15/16 ▲	272077	249421	1 x 1/2 x 12-15/16	1 x 1/2 x 11-3/8	32.4	26
3-7/16 ▲	272056	249420	7/8 x 7/16 x 12-15/16	7/8 x 7/16 x 5	36	28

♠ DODGE standard belt guards will not fit this motor mount.

† Shaft key furnished.

▲ Check the driven shaft and key for strength.

◆ Preferred bore. No bushing required for this bore size.

○ Stock TXT905 Reducers are drilled for vertical mounting.

♣ Made to order.

■ See page G2-201 for reducer part numbers and drill and tap dimensions. for Flange Mount TXT Reducers. Now available only as special factory order.

● Taper Bushed Reducers require bushing for all bore sizes.

♥ Use with Taper Bushed Reducers only. See page G2-203 for drill and tap information required to mount to reducer.

FEATURES/BENEFITS PAGE G2-3	NOMENCLATURE PAGE G2-11	SELECTION PAGE G2-13	RELATED PRODUCTS PAGE G2-152
--------------------------------	----------------------------	-------------------------	---------------------------------

SELECTION/DIMENSIONS



TORQUE-ARM Shaft Mount Speed Reducers TXT10 - DOUBLE REDUCTION TAPER BUSHED

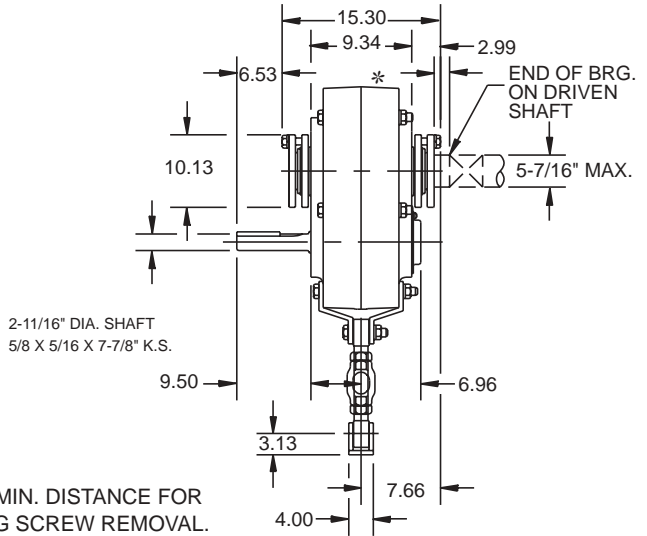
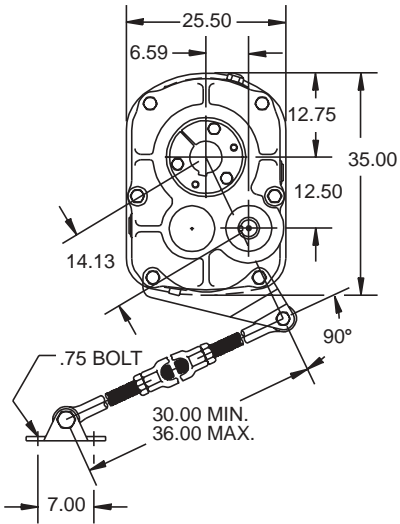

TXT10 - DOUBLE REDUCTION STRAIGHT BORE

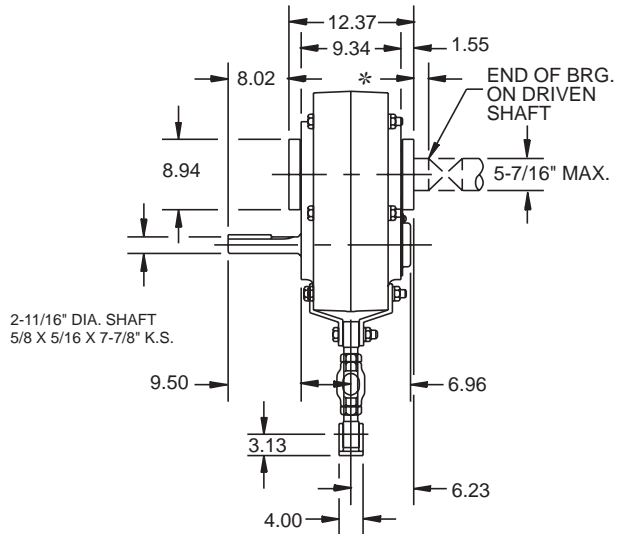
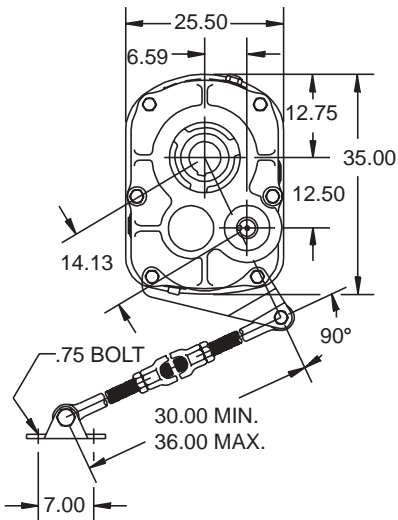

FEATURES/BENEFITS PAGE G2-3	NOMENCLATURE PAGE G2-11	SELECTION PAGE G2-13	RELATED PRODUCTS PAGE G2-152
--------------------------------	----------------------------	-------------------------	---------------------------------



TORQUE-ARM Shaft Mount Speed Reducers

TXT10 Taper Bushed Reducers ■ ○

Reducer Size	Part Number	AGMA Code	Actual Ratio	Weight
TXT1015T	272600	507D15	15.16	1020
TXT1024T	272601	507D24	24.30	1020

TXT10 Straight Bore Reducers ■ ○

Reducer Size	Part Number	AGMA Code	Actual Ratio	Weight
TXT1015S	272604	507D15	15.16	1020
TXT1024S	272605	507D24	24.30	1020

TXT10 Bushing Assemblies ●

Stock Bore Size	Part Number	Shaft Keyseat Required †		Weight		
		Tapered Bushing	Straight Bore Bushing	Tapered Bushing	Straight Bore Bushing	
5-7/16 (Max.)	272240	◆	1-1/4 x 5/8 x 14-1/16	1-1/4 x 5/8 x 12-3/8	26.50	-
4-15/16	272239	250422	1-1/4 x 5/8 x 14-1/16	1-1/4 x 5/8 x 12-3/8	33.50	12.90
4-7/16 ▲	272238	250421	1 x 1/2 x 14-1/16	1 x 1/2 x 12-3/8	38.40	31.40
3-15/16 ▲	272214	250420	1 x 1/2 x 14-1/16	1 x 1/2 x 6-5/8	44	33

♣ DODGE standard belt guards will not fit this motor mount.

† Shaft key furnished.

▲ Check the driven shaft and key for strength.

◆ Preferred bore. No bushing required for this bore size.

○ Stock TXT10 Reducers are drilled for vertical mounting.

♣ Made to order.

TXT10 Accessories

Description	Part Number	Weight
TA10 Standard Motor Mount (254T-365T)	250401	130
TA10 Special Motor Mount (404T-445T)	250404	150
TAB10 Bottom Motor Mount (254T-365T) ♣	250411	150
TXT10 Backstop Assembly	250260	5.60
Optional Filter Breather (1/2-14 NPT)	430049	0.20
TXT10-D TA Reducer Belt Guard (254T-445T)	250395	140
TXT10 Cooling Fan Assembly	272329	15
TXT10 Taconite Auxiliary Seal Kit ♥	272454	35.80

■ See page G2-201 for reducer part numbers and drill and tap dimensions. for Flange Mount TXT Reducers. Now available only as special factory order.

● Taper Bushed Reducers require bushing for all bore sizes.

♥ Use with Taper Bushed Reducers only. See page G2-203 for drill and tap information required to mount to reducer.

FEATURES/BENEFITS PAGE G2-3	NOMENCLATURE PAGE G2-11	SELECTION PAGE G2-13	RELATED PRODUCTS PAGE G2-152
--------------------------------	----------------------------	-------------------------	---------------------------------

SELECTION/DIMENSIONS



TORQUE-ARM Shaft Mount Speed Reducers TXT12 - DOUBLE REDUCTION TAPER BUSHED

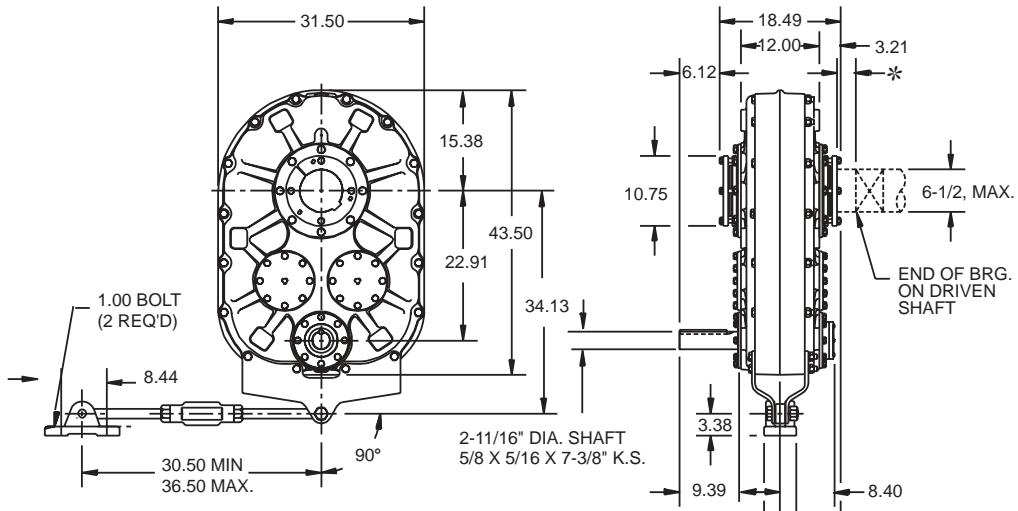

TXT12 Taper Bushed Reducers

Reducer Size	Part Number	AGMA Code	Actual Ratio	Weight
TXT1215TV	272615 ♣	608D15	14.89	1870
TXT1225TV	272617	608D25	24.65	1870

TXT12 Accessories

Description	Part Number	Weight
TA12 Standard Motor Mount (286T-445T)	272310	255
TXT12 Backstop Assembly	250260	5.6
Optional Filter Breather (1/2-14 NPT) †	430049	.2
TXT12 Cooling Fan Assembly	272330	15
Heat Exchanger Cooling Package	014148	55
TXT12 Taconite Auxiliary Seal Kit	272455	67.8
TXT12-D TA Reducer Belt Guard (320T-445T)	272688 ♣	170

TXT12 Tapered Bushing Assemblies ●

Stock Bore Size	Part Number	Shaft Keyseat Required †	Weight
6-1/2 (Max.)	272219	1-1/2 x 3/4 x 17-5/16	37.4
6-7/16	272218	1-1/2 x 3/4 x 17-5/16	38.4
6	272217	1-1/2 x 3/4 x 17-5/16	46.2
5-15/16	272216	1-1/2 x 3/4 x 17-5/16	47.3
5-7/16 ▲	272215	1-1/4 x 5/8 x 17-5/16	53.1

♣ DODGE standard belt guards will not fit this motor mount.

† Shaft key furnished.

▲ Check the driven shaft and key for strength.

♣ Made to order.

Reducers are supplied already drilled and tapped for vertical mounting and flange mounting. see page G2-201 for Flange Mounting dimensions

● Taper Bushed Reducers require bushing for all bore sizes.

FEATURES/BENEFITS
PAGE G2-3

NOMENCLATURE
PAGE G2-11

SELECTION
PAGE G2-13

RELATED PRODUCTS
PAGE G2-152



TORQUE-ARM Shaft Mount Speed Reducers TDT13 - DOUBLE REDUCTION TAPER BUSHED

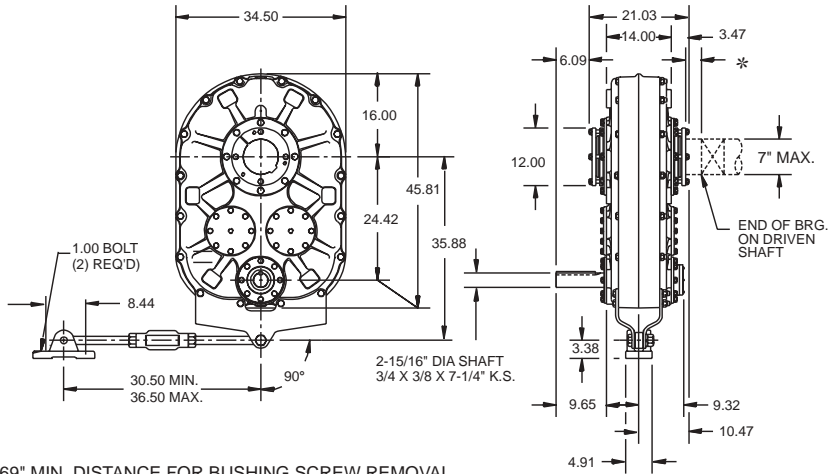

* 2.69" MIN. DISTANCE FOR BUSHING SCREW REMOVAL.

TDT13 Taper Bushed Reducer

Reducer Size	Part Number	AGMA Code	Actual Ratio	Weight
TDT1325T	272250	700D25	24.73	2476

TDT13 Accessories

Description	Part Number	Weight
TA13 Standard Motor Mount (324T-447T)	272313	290
TDT13 Backstop Assembly	272259	6.70
Optional Filter Breather (1/2-14 NPT) †	430049	0.20
TDT13 Cooling Fan Assembly	272331	20
Heat Exchanger Cooling Package	014148	55
TDT13 Taconite Auxiliary Seal Kit	272456	87

TDT13 Tapered Bushing Assemblies ●

Stock Bore Size	Part Number	Shaft Keyseat Required †	Weight
7 (Max.)	272257	1-3/4 x 3/4 x 19-9/16	74
6-1/2 ▲	272292	1-1/2 x 3/4 x 19-9/16	92
6 ▲	272291	1-1/2 x 3/4 x 19-9/16	111
5-15/16 ▲	272290	1-1/2 x 3/4 x 19-9/16	113

‡ DODGE standard belt guards will not fit this motor mount.

† Shaft key furnished.

▲ Check the driven shaft and key for strength.

Reducers are supplied already drilled and tapped for vertical mounting and flange mounting. see page G2-201 for Flange Mounting dimensions

● Taper Bushed Reducers require bushing for all bore sizes.

FEATURES/BENEFITS PAGE G2-3	NOMENCLATURE PAGE G2-11	SELECTION PAGE G2-13	RELATED PRODUCTS PAGE G2-152
--------------------------------	----------------------------	-------------------------	---------------------------------

SELECTION/DIMENSIONS



TORQUE-ARM Shaft Mount Speed Reducers TDT14 - DOUBLE REDUCTION TAPER BUSHED

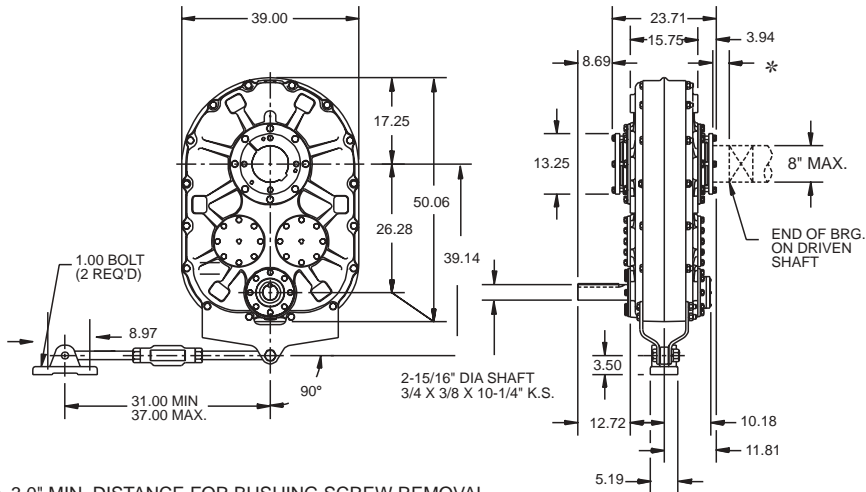

* 3.0" MIN. DISTANCE FOR BUSHING SCREW REMOVAL.

TDT14 Taper Bushed Reducer

Reducer Size	Part Number	AGMA Code	Actual Ratio	Weight
TDT1425T	272150 ♣	800D25	24.80	3436

TDT14 Accessories

Description	Part Number	Weight
TA14 Standard Motor Mount (324T-447T)	272318	295
TDT14 Backstop Assembly	272293	13.4
Optional Filter Breather (1/2-14 NPT) †	430049	.2
TDT14 Cooling Fan Assembly	272332	20
Heat Exchanger Cooling Package	014148	55
TDT14 Taconite Auxiliary Seal Kit	272457	131

TDT14 Tapered Bushing Assemblies ●

Stock Bore Size	Part Number	Shaft Keyseat Required †	Weight
8 (Max.)	272194	2 x 3/4 x 22-1/4	135
7 ▲	272193	1-3/4 x 3/4 x 22-1/4	144
6-1/2 ▲	272192 ♣	1-1/2 x 3/4 x 22-1/4	162.1
6 ▲	272191	1-1/2 x 3/4 x 22-1/4	188

♣ DODGE standard belt guards will not fit this motor mount.

† Shaft key furnished.

▲ Check the driven shaft and key for strength.

♣ Made to order.

Reducers are supplied already drilled and tapped for vertical mounting and flange mounting. see page G2-201 for Flange Mounting dimensions

● Taper Bushed Reducers require bushing for all bore sizes.

FEATURES/BENEFITS
PAGE G2-3

NOMENCLATURE
PAGE G2-11

SELECTION
PAGE G2-13

RELATED PRODUCTS
PAGE G2-152



TORQUE-ARM Shaft Mount Speed Reducers TDT15 - DOUBLE REDUCTION TAPER BUSHED

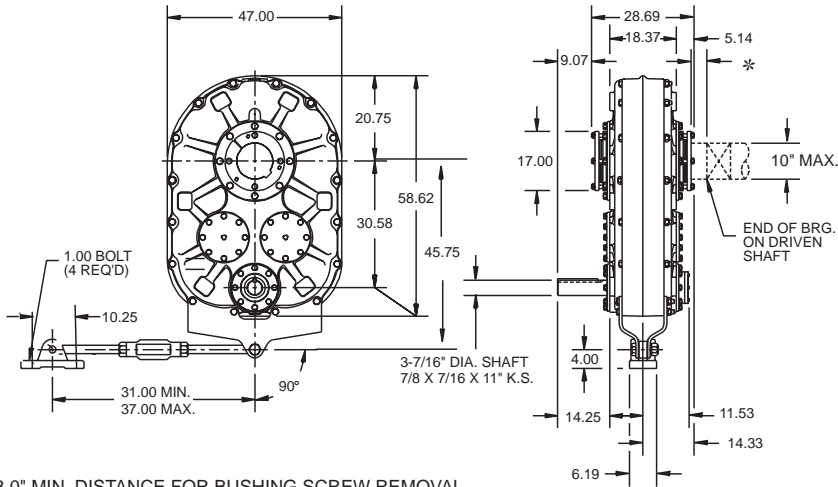

* 3.0" MIN. DISTANCE FOR BUSHING SCREW REMOVAL.

TDT15 Taper Bushed Reducer

Reducer Size	Part Number	AGMA Code	Actual Ratio	Weight
TDT1530T	272370 ♣	1000D30	30.64	5622

TDT15 Accessories

Description	Part Number	Weight
TA15 Standard Motor Mount (405T-449T)	272392	300
TDT15 Backstop Assembly	272293	13.40
Optional Filter Breather (1/2-14 NPT) ♣	430049	0.20
TDT15 Cooling Fan Assembly	272333	23
Heat Exchanger Cooling Package	014148	55
TDT15 Taconite Auxiliary Seal Kit ♣	272458	180

TDT15 Tapered Bushing Assemblies ●

Stock Bore Size	Part Number	Shaft Keyseat Required †	Weight
10 (Max.)	272395	2-1/2 x 7/8 x 27-5/16	202
9 ▲	272396	2 x 3/4 x 27-5/16	267
8-1/2 ▲	272397	2 x 3/4 x 27-5/16	300
8 ▲	272398	2 x 3/4 x 27-5/16	307

♣ DODGE standard belt guards will not fit this motor mount.

† Shaft key furnished.

▲ Check the driven shaft and key for strength.

♣ Made to order.

□ Reducers are supplied already drilled and tapped for vertical mounting and flange mounting. see page G2-201 for Flange Mounting dimensions

● Taper Bushed Reducers require bushing for all bore sizes.

FEATURES/BENEFITS PAGE G2-3	NOMENCLATURE PAGE G2-11	SELECTION PAGE G2-13	RELATED PRODUCTS PAGE G2-152
--------------------------------	----------------------------	-------------------------	---------------------------------



TORQUE-ARM Shaft Mount Speed Reducers

TABLE 5 - DODGE TORQUE-ARM REDUCERS AND ACCESSORIES COMPATIBILITY

TXT Reducer	Maximum Bore	AGMA Code	Input HP @75 RPM Output 15, 25:1	Input HP @100 RPM Output 5:1	Taper Bushed	Straight Bore	HYDROIL Style	Vertical Style	Motor Mount	Backstop	Taconite Auxiliary Seals	Belt Guards
TXT1	1-7/16"	107	4.15	4.49	Yes	Yes	Yes	Yes	Yes	Yes	Yes	Yes
TXT2	1-15/16"	115	7.52	7.70	Yes	Yes	Yes	Yes	Yes	Yes	Yes	Yes
TXT3	2-3/16"	203	12.7	11.7	Yes	Yes	Yes	Yes	Yes	Yes	Yes	Yes
TXT4	2-7/16"	207	19.3	19.6	Yes	Yes	Yes	Yes	Yes	Yes	Yes	Yes
TXT5	2-15/16"	215	29.9	25.0	Yes	Yes	Yes	Yes	Yes	Yes	Yes	Yes
TXT6	3-7/16"	307	50.3	51.6	Yes	Yes	Yes	Yes	Yes	Yes	Yes	Yes
TXT7	3-15/16"	315	72.3	87.4	Yes	Yes	Yes	Yes	Yes	Yes	Yes	Yes
TXT8	4-7/16"	407	106.9	111.0	Yes	Yes	-	Yes	Yes	Yes	Yes	Yes
TXT9	4-15/16"	415	154.7	140.0	Yes	Yes	-	Yes	Yes	Yes	Yes	Yes
TXT10	5-7/16"	507	216.0	-	Yes	Yes	-	Yes	Yes	Yes	Yes	Yes
TXT12	6-1/2"	608	275.0	-	Yes	-	-	Yes	Yes	Yes	Yes	Yes
TDT13	7"	700	374.0	-	Yes	-	-	Yes	Yes	Yes	Yes	Yes
TDT14	8"	800	561.0	-	Yes	-	-	Yes	Yes	Yes	Yes	Yes
TDT15	10"	1000	-	-	Yes	-	-	Yes	Yes	Yes	Yes	Yes

TABLE 6 - DODGE SCREW CONVEYOR DRIVE REDUCERS AND ACCESSORIES COMPATIBILITY

SCXT Reducer	AGMA Code	Input HP@75 RPM Output 15,25:1	Input HP@100 RPM Output 5:1	HYDROIL Style	Drive Shafts	Adapter	Motor Mount	Taconite Auxiliary Seals	Belt Guards
SCXT1	107	4.15	4.49	Yes	Yes	Yes	Yes	Yes	Yes
SCXT2	115	7.52	7.70	Yes	Yes	Yes	Yes	Yes	Yes
SCXT3	203	12.70	11.70	Yes	Yes	Yes	Yes	Yes	Yes
SCXT4	207	19.30	19.60	Yes	Yes	Yes	Yes	Yes	Yes
SCXT5	215	29.90	25.00	Yes	Yes	Yes	Yes	Yes	Yes
SCXT6	307	50.30	51.60	Yes	Yes	Yes	Yes	Yes	Yes
SCXT7	315	72.30	87.40	Yes	Yes	Yes	Yes	Yes	Yes
SCXT8	407	106.90	111.00	-	Yes	Yes	Yes	Yes	Yes



TORQUE-ARM Shaft Mount Speed Reducers

**TABLE 7 - NEMA MOTOR INFORMATION
(1750 RPM)**

Horsepower	NEMA Motor Frame	Shaft Diameter	Minimum Sheave Diameters
1	143T	7/8	2.2
1-1/2	145T	7/8	2.4
2	145T	7/8	2.4
3	182T	1-1/8	2.4
5	184T	1-1/8	3.0
7-1/2	213T	1-3/8	3.0
10	215T	1-3/8	3.8
15	254T	1-5/8	4.4
20	256T	1-5/8	4.4
25	284T	1-7/8	4.4
30	286T	1-7/8	5.2
40	324T	2-1/8	6.0
50	326T	2-1/8	6.8
60	364T	2-3/8	7.4
75	365T	2-3/8	8.6
100	+405T	2-7/8	8.6
125	+444T	3-3/8	10.5
150	+445T	3-3/8	10.5
200	+447T	3-3/8	13.2

+ Energy Efficient (TEFC-XE) Frame

**TABLE 8 - MINIMUM SHEAVE DIAMETERS FOR DODGE
TORQUE-ARM REDUCERS**

TXT, SCXT Reducer	Single Reduction		Double Reduction			
	Shaft Diameter	5:1	Shaft Diameter	9:1	15:1	25:1
1	1-1/8	4.0	3/4	4.0	3.0	3.0
2	1-7/16	3.0	1-1/8	5.0	3.0	3.0
3	1-5/8	7.0	1-1/4	5.0	4.0	4.0
4	1-15/16	7.5	1-7/16	6.5	4.6	4.6
5	2-3/16	9.5	1-15/16	7.0	5.4	5.4
6	2-3/16	6.5	2-3/16	7.0	6.2	6.2
7	2-7/16	7.5	2-7/16	7.0	6.2	6.2
8	2-7/16	9.2	2-7/16		6.2	6.2
9	2-7/16	9.5	2-7/16		8.0	8.0
10			2-11/16		8.5	8.5
12			2-11/16		9.5	9.5
13			2-15/16			12.0
14			2-15/16			15.0
15			3-7/16			20.0

MODIFICATIONS/ ACCESSORIES



TORQUE-ARM Shaft Mount Speed Reducers

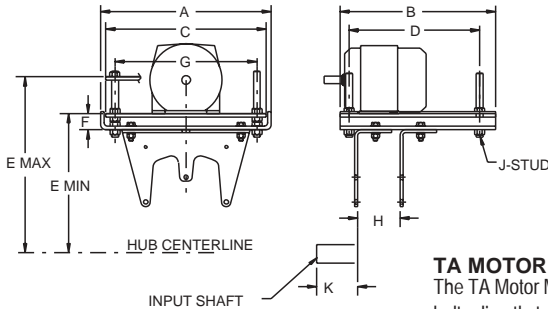

TA MOTOR MOUNTS

The TA Motor Mount is a rugged all steel unit which requires no drilling and no foundation. It bolts directly to the top of the TORQUE-ARM reducer and can be located in any position around the shaft. It permits easy belt tensioning.

Each motor mount accommodates a wide variety of NEMA motor frames - see table below.

All motor mount fasteners are supplied with zinc-plated finish as standard Bolt hole configuration will also allow this mount to fasten to the top of a Screw Conveyor Drive reducer of equivalent size.

TORQUE-ARM MOTOR MOUNTS - TA1M THRU TA7M

MOTOR MOUNT NO. ■	PART NUMBER ●	WT.	REDUCER SIZE	NEMA MOTOR FRAME	A	B	C	D	E ◆		F	G	H	J	K
									MIN	MAX					
TA1M	241391	37	TXT1	56T - 215T	14.63	11.00	13.50	9.25	10.03	14.18	1.59	12.00	3.38	5/8 x 7	3.88
			TXT2						10.59	14.75					4.18
TA3M	243391	40	TXT3A	56T - 215T	14.63	11.00	13.50	9.25	11.59	15.78	1.62	12.00	4.25	5/8 x 7	4.88
	243393 ▲	70		254T - 256T	18.63	17.00	17.50	14.25	11.59	15.78					
TA4M	244391	75	TXT4A	143T - 286T	18.63	17.00	17.50	14.25	11.96	16.73	1.78	15.50	4.63	3/4 x 8	6.13
TA5M	245391	76	TXT5B	143T - 286T	18.63	17.00	17.50	14.25	12.53	17.28	1.84	15.50	4.13	3/4 x 8	6.65
	245393 ▲			324T - 326T	20.50	18.50	19.25	16.50	12.53	17.28					
TA6M	246391	99	TXT6	143T - 326T	20.50	18.50	19.25	16.50	14.56	19.31	1.84	17.50	4.50	3/4 x 8	7.31
TA7M	247395	110	TXT7	143T - 365T	22.50	19.00	21.25	16.50	17.62	22.13	2.50	19.25	4.75	1 x 9	7.81

V-BELT DRIVE CENTER DISTANCES FOR TA1M THRU TA7M TORQUE-ARM MOTOR MOUNTS

MOTOR MOUNT NO.	REDUCER SIZE	CENTER DISTANCES FOR VARIOUS NEMA MOTOR FRAMES															
		56		140		180		210		250		280		320		360	
		MIN	MAX	MIN	MAX	MIN	MAX	MIN	MAX	MIN	MAX	MIN	MAX	MIN	MAX	MIN	MAX
TA1M	TXT1	17.6	21.0	17.6	21.0	18.5	22.0	19.3	22.7								
	TXT2	18.7	22.1	18.7	22.1	19.7	23.1	20.5	23.9								
TA3M	TXT3A	20.2	23.6	20.2	23.6	21.2	24.6	22.0	25.3	23.0	26.3						
TA4M	TXT4A			21.2	25.2	22.2	26.2	23.0	26.9	23.9	27.9	24.7	28.7				
TA5M	TXT5B			22.7	26.6	23.7	27.6	24.4	28.4	25.4	29.4	26.2	30.1	27.2	31.1		
TA6M	TXT6			25.9	29.7	26.9	30.7	27.6	31.4	28.6	32.4	29.4	33.2	30.4	34.2		
TA7M	TXT7			30.6	34.4	31.6	35.4	32.4	36.2	33.4	37.2	34.1	37.9	35.1	38.9	36.1	40.0

- Can be used with any ratio TORQUE-ARM Reducer (5, 9, 15, 25)
- Necessary mounting bolts are included
- ▲ Made to order belt buards required for these motor mounts. Consult DODGE.
- ◆ Provides for V-belt adjustment

FEATURES/BENEFITS PAGE G2-3	NOMENCLATURE PAGE G2-11	SELECTION/DIMENSIONS PAGE G2-28	RELATED PRODUCTS PAGE G2-152
--------------------------------	----------------------------	------------------------------------	---------------------------------



TORQUE-ARM Shaft Mount Speed Reducers

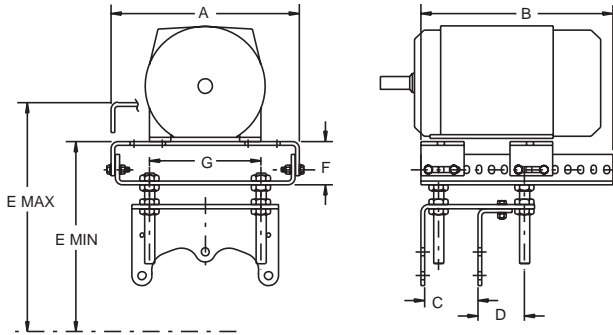

TORQUE-ARM MOTOR MOUNTS - TA8 THRU TA15

MOTOR MOUNT NO.	PART NUMBER	WT.	REDUCER SIZE	NOMINAL RATIO	NEMA MOTOR FRAME	A	B	C	D	E \blacklozenge		F	G
										MIN	MAX		
TA8	248401	119	TXT8	15, 25 5	213T - 365T 254T - 365T	18.63	19.00	5.25	4.36	19.40	23.90	4.25	11.00
TA9	249401	120	TXT9	15, 26 5	213T - 365T 284T - 365T	18.63	19.00	5.25	4.63	21.46	25.90	4.25	11.00
	249399 \clubsuit \blacktriangle	125		15, 26	404T - 445T								
TA10	250401	130	TXT10	15, 24	254T - 365T	18.63	19.00	6.00	3.88	22.60	27.09	4.25	11.00
	250404	200			404T - 445T	25.06	24.00	6.00	3.88	21.86	27.38	3.81	18.50
TA12	272310	255	TXT12	15, 25	286T - 445T	25.06	24.00	7.63	5.25	25.65	31.13	3.81	18.50
TA13	272313	290	TDT13	25	324T - 445T	25.06	24.00	8.75	8.63	25.65	31.13	3.81	18.50
TA14	272318	295	TDT14	25	324T - 447T	25.06	24.00	10.00	7.38	25.81	31.31	3.81	18.50
TA15	272392	320	TDT15	30	405T - 449T	25.06	24.00	12.63	5.75	33.50	39.00	3.81	18.50

V-BELT DRIVE CENTER DISTANCES FOR TA8 THRU TA15 TORQUE-ARM MOTOR MOUNTS

MOTOR MOUNT NO.	REDUCER SIZE	NOMINAL RATIO	CENTER DISTANCES FOR VARIOUS NEMA MOTOR FRAMES													
			210		250		280		320		360		400		440	
			MIN	MAX	MIN	MAX	MIN	MAX	MIN	MAX	MIN	MAX	MIN	MAX	MIN	MAX
TA8	TXT8	15, 25	35.5	40.5	36.4	41.2	37.2	42.2	38.2	43.2	39.2	44.2				
		5			37.2	41.5	37.9	42.3	38.9	43.3	39.9	44.3				
TA9	TXT9	15, 26	38.0	43.0	39.0	44.0	39.8	44.7	40.7	45.7	41.7	46.7	42.8	47.7		
		5					40.5	44.8	41.5	45.8	42.5	46.8	43.5	47.8		
TA10	TXT10	15, 24			42.6	47.5	43.3	48.2	44.3	49.2	45.3	50.2	45.8	50.7	47.3	51.7
TA12	TXT12	15, 25					57.0	61.0	57.7	62.1	58.7	63.1	59.7	64.1	60.7	65.1
TA13	TDT13	25							59.7	65.1	60.7	66.1	61.7	67.1	62.0	66.7
TA14	TDT14	25							61.7	67.1	62.7	68.1	63.7	69.1	64.7	70.1
TA15	TDT15	30											75.0	80.5	76.0	81.5

- Necessary mounting bolts are included
- ▲ Made to order belt guards required for these motor mounts. Consult DODGE.
- ◆ Provides for V-belt adjustment
- ♣ Made to order.

FEATURES/BENEFITS PAGE G2-3	NOMENCLATURE PAGE G2-11	SELECTION/DIMENSIONS PAGE G2-28	RELATED PRODUCTS PAGE G2-152
--------------------------------	----------------------------	------------------------------------	---------------------------------

MODIFICATIONS/ ACCESSORIES



TORQUE-ARM Shaft Mount Speed Reducers

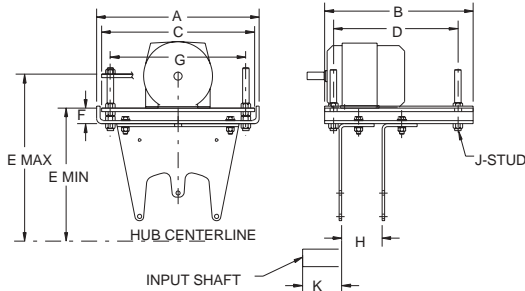

TAML LONG MOTOR MOUNTS

The TAML Motor Mount has longer support brackets, which allows for more clearance between the conveyor pulley and the bottom plate of the motor mount. (Reference table below for clearance dimensions). The motor mount is a rugged all steel unit which requires no drilling and no foundation. It bolts directly to the top of the TORQUE-ARM reducer and can be located in any position around the shaft. It permits easy belt tensioning and accommodates a wide variety of NEMA motor frames.

All motor mount fasteners are supplied with zinc-plated finish as standard.

Bolt hole configuration will also allow this mount to fasten to the top of a Screw Conveyor Drive Reducer of equivalent size.

TORQUE-ARM LONG MOTOR MOUNTS - TA3ML THRU TA7ML ▲ †

MOTOR MOUNT NO. ■	PART NUMBER ●	WT.	REDUCER SIZE	NEMA MOTOR FRAME	A	B	C	D	E ◆		F	G	H	J	K
									MIN	MAX					
TA3ML	243392	42	TXT3A	56T - 215T	14.63	11.00	13.50	9.25	14.59	18.72	1.59	12.00	4.25	5/8 x 7	4.88
TA4ML	244392	78	TXT4A	143T - 286T	18.63	17.00	17.50	14.25	16.46	21.20	1.78	15.50	4.63	3/4 x 8	6.13
TA5ML	245392	80	TXT5B	143T - 286T	18.63	17.00	17.50	14.25	19.28	24.03	1.84	15.50	4.13	3/4 x 8	6.65
TA6ML	246390	102	TXT6	143T - 326T	20.50	18.50	19.25	16.50	28.56	33.30	1.84	17.50	4.50	3/4 x 8	7.31
TA7ML	247396	115	TXT7	143T - 326T	22.50	19.00	21.25	16.50	32.46	37.20	1.84	19.25	4.75	3/4 x 8	7.81

V-BELT DRIVE CENTER DISTANCES FOR TA3ML THRU TA7ML TORQUE-ARM LONG MOTOR MOUNTS

MOTOR MOUNT NO.	REDUCER SIZE	CENTER DISTANCES FOR VARIOUS NEMA MOTOR FRAMES													
		56		140		180		210		250		280		320	
		MIN	MAX	MIN	MAX	MIN	MAX	MIN	MAX	MIN	MAX	MIN	MAX	MIN	MAX
TA3ML	TXT3A	23.1	26.5	23.1	26.5	24.1	27.5	24.9	28.3						
TA4ML	TXT4A			25.6	30.6	26.7	30.6	27.4	31.4	28.3	32.4	29.2	33.1		
TA5ML	TXT5B			29.4	33.4	30.4	34.3	31.1	35.1	32.1	36.1	32.9	36.8		
TA6ML	TXT6					40.8	44.6	41.6	45.4	42.6	46.4	43.3	47.1	44.3	48.1
TA7ML	TXT7					47.0	50.8	47.7	51.5	48.7	52.5	49.5	53.3	50.5	54.3

CLEARANCE DIMENSIONS ■

REDUCER	MOTOR MOUNT	CLEARANCE DIMENSIONS (1)
TXT1	TA1M	7.63
TXT2	TA1M	8.25
TXT3A	TA3M	9.25
TXT4A	TA4M	9.44
TXT5B	TA5M	10.00
TXT6	TA6M	11.97
TXT7	TA7M	14.38

CLEARANCE DIMENSIONS ■

REDUCER	MOTOR MOUNT	CLEARANCE DIMENSIONS (1)
TXT3A	TA3ML	12.25
TXT4A	TA4ML	13.94
TXT5B	TA5ML	16.75
TXT6	TA6ML	25.96
TXT7	TA7ML	29.88

(1) Distance from centerline of head shaft (reducer bore) and lowest component of motor mount hardware extending over top of convey

- Can be used with any ratio TORQUE-ARM Reducer (5, 9, 15, 25)
- Necessary mounting bolts are included
- ▲ Made to order belt boards required for these motor mounts. Consult DODGE.
- ◆ Provides for V-belt adjustment
- † Consult DODGE for Long Motor Mounts for reducers TXT8 and larger.

FEATURES/BENEFITS PAGE G2-3	NOMENCLATURE PAGE G2-11	SELECTION/DIMENSIONS PAGE G2-28	RELATED PRODUCTS PAGE G2-152
--------------------------------	----------------------------	------------------------------------	---------------------------------



TORQUE-ARM Shaft Mount Speed Reducers

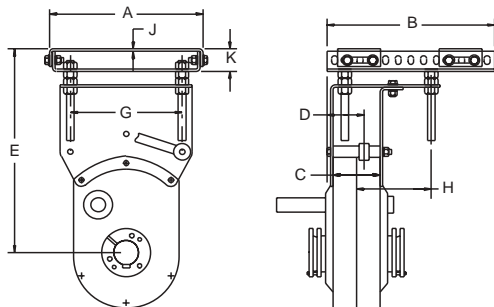

TAB BOTTOM MOTOR MOUNTS

For those applications where space constraints do not allow a DODGE TORQUE-ARM motor mount to be mounted from the top end of the reducer with our standard TORQUE-ARM motor mounts, TAB Bottom Motor Mounts are available. The TAB Motor Mount is a rugged all-steel unit which requires no drilling or foundation. It bolts directly to the bottom of a TORQUE-ARM reducer housing and also serves as a support member for the TORQUE-ARM rod assembly. Each mount accommodates a wide variety of NEMA AC motor frames. For initial belt installation, the adjusting screws can be set at a minimum position which offers adequate future V-belt adjustment.

TORQUE-ARM BOTTOM MOTOR MOUNTS - TAB 1 THRU TAB 10 ▲

MOTOR MOUNT NO.	PART NUMBER	WT.	REDUCER SIZE	NOMINAL RATIO	NEMA MOTOR FRAME	A	B	C	D	E ◆		G	H	J	K
										MIN	MAX				
TAB1	241421	40	TXT1	5, 9, 15, 25	56T - 215T	12-1/8	11-1/2	3-3/8	2-43/64	14-17/64	17-61/64	8	5-25/32	1/4	2-3/8
TAB2	242421	45	TXT2	5, 9, 15, 25	56T - 215T	12-1/8	11-1/2	3-3/8	2-43/64	14-29/32	18-19/32	8	5-25/32	1/4	2-3/8
TAB3	243404	60	TXT3A	5, 9, 15, 25	143T - 286T	15-1/8	16-1/2	4-1/4	3-15/32	19-1/4	23-7/8	11	5-13/32	1/4	2-3/8
TAB4	244404	65	TXT4A	5, 9, 15, 25	143T - 145T 182T - 326T	15-1/8	16-1/2	4-5/8	5-13/32 3-21/32	20-13/32	25-1/32	11	5-1/32	1/4	2-3/8
TAB5	245405	70	TXT5B	5, 9, 15, 25	143T - 145T 182T - 326T	15-1/8	16-1/2	4-1/8	5-21/64 3-37/64	21-15/32	26-3/32	11	5-17/32	1/4	2-3/8
TAB6	246392	75	TXT6	5, 9, 15, 25	182T - 215T 254T - 326T	15-1/8	16-1/2	4-1/2	5-5/32 3-13/32	24-1/4	28-13/16	11	5-17/16	1/4	2-3/8
TAB7	247404	85	TXT7	5, 9, 15, 25	182T - 215T 254T - 326T	15-1/8	16-1/2	4-3/4	5-1/2 3-3/4	27-3/4	32-1/4	11	5-1/8	1/4	2-3/8
TAB8	248406	90	TXT8	5, 15, 25	213T - 256T 284T - 365T	15-1/8	19	5-1/4	3-5/8 3-7/8	33-13/32	37-25/32	11	4-5/8	3/8	4-1/4
TAB9	249404	95	TXT9	5, 15, 26	213T - 256T 284T - 365T	18-5/8	19	5-1/4	5-5/8 3-7/8	34-29/32	39-9/32	11	4-5/8	3/8	4-1/4
TAB10	250411	105	TXT10	15, 24	254T - 365T	25-1/16	24	6	4-23/32	36-3/32	41-17/32	18-1/2	4-1/8	3/8	3-13/16

● Necessary mounting bolts are included.

▲ Made to order belt guards required for these motor mounts. Consult DODGE

◆ Provides for V-belt adjustment.

V-BELT DRIVE CENTER DISTANCES FOR TORQUE-ARM BOTTOM MOTOR MOUNTS

MOTOR MOUNT NO.	REDUCER SIZE	NOMINAL RATIO	CENTER DISTANCES FOR VARIOUS NEMA MOTOR FRAMES															
			56		140		180		210		250		280		320		360	
			MIN	MAX	MIN	MAX	MIN	MAX	MIN	MAX	MIN	MAX	MIN	MAX	MIN	MAX	MIN	MAX
TAB1	TXT1	9, 15, 25	14.70	18.40	14.70	18.40	15.70	19.40										
		5	14.50	18.20	14.50	18.20	16.30	19.20	17.20	19.90								
TAB2	TXT2	9, 15, 25	14.80	18.50	14.80	18.50	15.80	19.50	16.50	20.20								
		5			14.60	18.20	15.60	19.20	16.30	20.00								
TAB3	TXT3A	9, 15, 25	18.70	23.30	18.70	23.30	19.70	24.30	20.50	25.10								
		5			19.50	24.10	20.20	24.80	21.20	25.80								
TAB4	TXT4A	9, 15, 25	19.30	23.90	19.30	23.90	20.30	24.90	21.10	25.70	22.10	26.60						
		5			20.00	24.70	20.80	25.40	21.80	26.40	22.50	27.20						
TAB5	TXT5B	9, 15, 25			19.50	24.10	20.50	25.10	21.30	25.90	22.30	26.90	23.00	27.60				
	TXT5A	5					20.90	25.50	21.90	26.50	22.60	27.20	23.60	28.20				
TAB6	TXT6	9, 15, 25			21.40	25.90	22.40	26.90	23.10	27.60	24.10	28.60	24.90	29.40	25.80	30.40		
		5							23.60	28.20	24.40	28.90	25.40	29.90				
TAB7	TXT7	9, 15, 25					24.50	28.90	25.20	29.70	26.20	30.60	26.90	31.40	27.90	32.40		
		5							25.70	30.20	26.40	30.90	27.40	31.90				
TAB8	TXT8	15, 25							29.50	33.80	30.50	34.80	31.20	35.60	32.20	36.50	33.20	37.50
		5									30.50	34.90	31.50	35.90	32.50	36.90		
TAB9	TXT9	15, 26							29.90	34.10	30.80	35.10	31.60	35.90	32.50	36.80	33.50	37.80
		5											31.70	36.10	32.70	37.10		
TAB10	TXT10	15, 24									32.00	37.00	32.80	38.00	33.70	39.00	34.70	40.00

FEATURES/BENEFITS PAGE G2-3	NOMENCLATURE PAGE G2-11	SELECTION/DIMENSIONS PAGE G2-28	RELATED PRODUCTS PAGE G2-152
--------------------------------	----------------------------	------------------------------------	---------------------------------

MODIFICATIONS/ ACCESSORIES





TORQUE-ARM Shaft Mount Speed Reducers

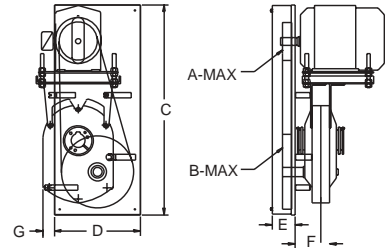

SLOTTED METAL PANEL BELT GUARD

Belt guards with mounting straps for TXT Reducers will fit standard TA motor mounts. The belt guards are designed to fit most common sheave diameters. They mount easily with no machining required.



BELT GUARDS FOR DOUBLE REDUCTION TXT REDUCERS (9, 15, 25:1) WITH STANDARD MOTOR MOUNTS ■

REDUCE R SIZE	BELT GUARD SIZE	PART NUMBER	MOTOR MOUNT NO.	WT.	NEMA MOTOR FRAME	CENTER DISTANCE		A	B	C	D	E	F	G
						MIN	MAX							
TXT1	TXT1D	241395	TA1M	30	56T-215T	17.6	22.7	5.0	12.0	32.0	13.0	3.50	3.63	-
TXT2	TXT2D	242395	TA1M	36	56T-215T	18.7	23.9	6.0	12.0	34.0	15.0	4.00	3.50	-
TXT3A	TXT3D	243387 ▲	TA3M	43	56T-215T	20.2	25.3	7.0	14.0	37.0	17.0	4.00	3.94	-
TXT4A	TXT4D	244395	TA4M	54	143T-286T	21.2	28.7	7.0	15.0	43.0	18.0	4.50	5.19	-
TXT5B	TXT5D	245387 ▲	TA5M	75	143T-286T	22.7	30.2	7.0	15.0	45.0	18.0	4.25	5.13	0.625
TXT6	TXT6D	246366	TA6M	83	143T-326T	25.9	34.2	8.0	18.0	50.0	20.0	6.00	6.06	1.63
TXT7	TXT7D	247390	TA7M	90	143T-365T	30.6	40	10.0	20.0	56.0	23.0	6.00	6.88	0.500
TXT8	TXT8D	248395	TA8	107	213T-365T	35.4	44.2	12.0	25.0	63.0	27.0	6.50	7.46	0.156
TXT9	TXT9D	249395 ▲	TA9	125	213T-365T	38	46.7	12.0	25.0	66.0	30.0	9.00	7.63	2.91
TXT10	TXT10D	250395	TA10	140	254T-445T	42.5	50.8	12.0	25.0	72.5	30.0	9.00	8.25	4.31
TXT12	TXT12D	272688 ♣	TA12	170	320T-445T	58.1	66.6	15.0	30.0	91.0	34.0	9.50	8.13	-

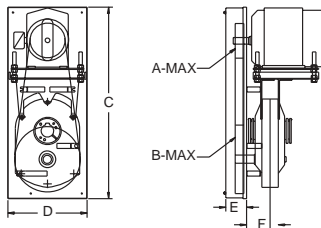

BELT GUARDS FOR SINGLE REDUCTION TXT REDUCERS (5:1) WITH STANDARD MOTOR MOUNTS ■

REDUCER SIZE	BELT GUARD SIZE	PART NUMBER	MOTOR MOUNT NO.	WT.	NEMA MOTOR FRAME	CENTER DISTANCE		A	B	C	D	E	F
						MIN	MAX						
TXT105	TXT1S	241397	TA1M	30	56T-215T	17.6	22.7	5.0	12.0	32.0	13.0	3.50	3.63
TXT205	TXT2S	242397	TA1M	36	56T-215T	18.7	23.9	6.0	13.0	34.0	15.0	4.00	3.50
TXT305A	TXT3S	243389 ▲	TA3M	43	56T-215T	20.2	25.3	7.0	15.0	37.0	17.0	4.00	3.94
TXT405A	TXT4S	244397	TA4M	54	143T-286T	21.2	28.7	8.0	16.0	43.0	18.0	4.50	5.19
TXT505A	TXT5S	245389 ▲	TA5M	59	143T-286T	22.7	30.2	8.0	16.0	45.0	18.0	5.25	5.13
TXT605	TXT6S	246368	TA6M	95	143T-326T	25.9	34.2	10.0	18.0	50.0	20.0	6.00	6.06
TXT705	TXT7S	247392	TA7M	112	143T-365T	30.6	40.0	10.0	25.0	58.0	27.0	6.00	6.88
TXT805	TXT8S	248397	TA8	125	213T-365T	35.1	43.9	13.0	30.0	66.0	32.0	6.50	7.46
TXT905	TXT9S	249397 ▲	TA9	156	213T-365T	37.6	46.4	13.0	30.0	69.0	32.0	9.00	7.63

▲ These belt guards do not fit the larger frame, higher H.P. TORQUE-ARM motor mounts on pages G2-72 and G2-73.

■ These belt guards do not fit TAB Bottom Motor Mounts. Consult DODGE for made-to-order belt guards for use with Bottom Motor Mounts

♣ Made to order.

FEATURES/BENEFITS
PAGE G2-3

NOMENCLATURE
PAGE G2-11

SELECTION/DIMENSIONS
PAGE G2-28

RELATED PRODUCTS
PAGE G2-152



TORQUE-ARM Shaft Mount Speed Reducers

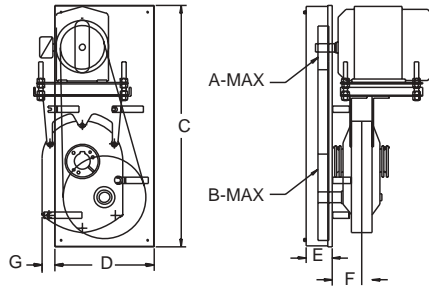

BELT GUARDS FOR DOUBLE REDUCTION TXT REDUCERS (9, 15, 25:1) WITH LONG MOTOR MOUNTS

REDUCER SIZE	BELT GUARD-SIZE	PART NUMBER	MOTOR MOUNT NO.	WT.	NEMA MOTOR FRAME	CENTER DISTANCE		A	B	C	D	E	F	G
						MIN	MAX							
TXT3A	TXT3DLMM	243153 ▲	TA3ML	52	56T-215T	23.1	28.3	7.0	14.0	40.0	17.0	4.00	3.94	-
TXT4A	TXT4DLMM	244151	TA4ML	65	143T-286T	25.6	33.1	7.0	15.0	47.5	18.0	4.50	5.19	-
TXT5B	TXT5DLMM	245102 ▲	TA5ML	90	143T-286T	29.4	36.8	7.0	15.0	51.7	18.0	4.25	5.13	0.625
TXT6	TXT6DLMM	246147	TA6ML	100	143T-326T	39.8	48.1	8.0	18.0	64.0	20.0	6.00	6.06	1.63
TXT7	TXT7DLMM	247152	TA7ML	108	143T-365T	46.0	55.3	10.0	20.0	71.5	23.0	6.00	6.88	0.500

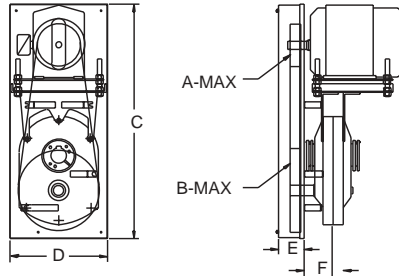

BELT GUARDS FOR SINGLE REDUCTION TXT REDUCERS (5:1) WITH LONG MOTOR MOUNTS

REDUCE R SIZE	BELT GUARD SIZE	PART NUMBER	MOTOR MOUNT NO.	WT.	NEMA MOTOR FRAME	CENTER DISTANCE		A	B	C	D	E	F
						MIN	MAX						
TXT305A	TXT3SLMM	243164 ▲	TA3ML	55	56T-215T	23.1	28.3	7.0	15.0	40.0	17.0	4.00	3.94
TXT405A	TXT4SLMM	244164	TA4ML	65	143T-286T	25.6	33.1	8.0	16.0	47.5	18.0	4.50	5.19
TXT505A	TXT5SLMM	245162 ▲	TA5ML	90	143T-286T	29.4	36.8	8.0	16.0	51.7	18.0	4.25	5.13
TXT605	TXT6SLMM	246132	TA6ML	100	143T-326T	39.8	48.1	10.0	18.0	64.0	20.0	6.00	6.06
TXT705	TXT7SLMM	247146	TA7ML	135	143T-365T	46.0	55.3	10.0	20.0	71.5	23.0	6.00	6.88

▲ These belt guards do not fit the larger frame, higher H.P. TORQUE-ARM motor mounts on pages G2-72 and G2-73

FEATURES/BENEFITS PAGE G2-3	NOMENCLATURE PAGE G2-11	SELECTION/DIMENSIONS PAGE G2-28	RELATED PRODUCTS PAGE G2-152
--------------------------------	----------------------------	------------------------------------	---------------------------------



TORQUE-ARM Shaft Mount Speed Reducers BACKSTOP ASSEMBLIES FOR TORQUE-ARM REDUCERS

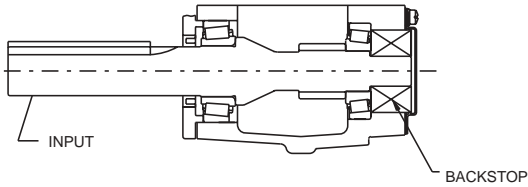

Backstops are offered for service conditions that require the prevention of reverse direction. They can be quickly installed by removing cover plate and slipping the backstop over the input shaft. After cover is replaced, backstop becomes completely sealed inside the reducer case. Since the reducer lubricates the backstop, no additional lubrication is required.

When ordering backstops, specify by reducer size and ratio. Keys are included in each backstop assembly.

Warning: Backstops are not recommended for applications involving energy absorption and shock or torque loads in excess of reducer ratings or on applications such as chair lifts, amusement rides, etc., where the safety of persons or property is dependent on their function. On such applications, other safety devices should be provided.

BACKSTOP ASSEMBLIES ■

Reducer Size	Nominal Ratio	Part Number	Weight
TXT1	5, 9, 15, 25	242101	0.6
TXT2	5, 9, 15, 25	252101	1.0
TXT3A	9, 15, 25	243106	0.6
TXT3A	5	252101	1.0
TXT4A	9, 15, 25	244106	1.2
TXT4A	5	244148	0.9
TXT5B	9, 15, 25	245154	2.2
TXT5A	5	246101	1.8
TXT6	5, 9, 15, 25	246092	2.5
TXT7	5, 9, 15, 25	247260	2.8
TXT8	15, 25	249260	3.8
TXT8	5	250260	5.6
TXT9	15, 26	249260	3.8
TXT9	5	272259	6.7
TXT10	15, 24	250260	5.6
TXT12	15, 25	250260	5.6
TDT13	25	272259	6.7
TDT14	25	272293	13.4
TDT15	30	272293	13.4

■ See page G2-211 for complete listing of Backstop assemblies for all generations of DODGE TORQUE-ARM reducers.

FILTER BREATHERS FOR TORQUE-ARM REDUCERS

FILTER BREATHERS ★



Reducer Size	Part Number	Plug Dimensions
TXT1 to TXT4	430048	3/8-18 NPSF
TXT5 to TXT10	430049	1/2-14 NPSF

★ Breathers fit all reducer ratios.

Filter air breathers are designed for use in dusty atmospheres where the standard Torque-Arm breather may become clogged and inoperative. The 40 micron mesh opening allows the reducer to breathe, yet keep dust out, under the most extreme conditions. Clean oil is necessary for proper service and long gear and bearing life. Breathers may be used in all reducers and screw conveyor drives. When ordering, specify reducer size.



TORQUE-ARM Shaft Mount Speed Reducers AUXILIARY SEAL KITS FOR TORQUE-ARM REDUCERS

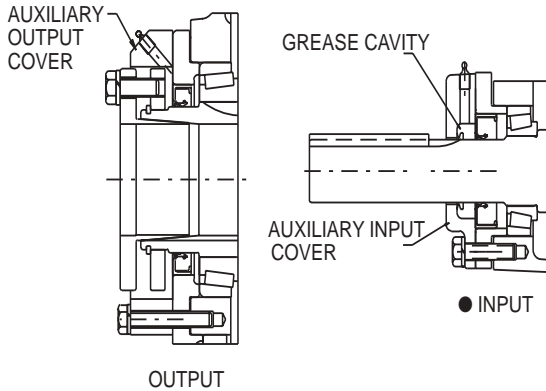

An Auxiliary Seal Kit consists of two output seals and one input seal with necessary mounting hardware. Seal rings are equipped with a standard grease fitting and a large cavity which permits grease purging of the seal in severe applications, such as taconite mining, rock processing, fertilizer processing, etc. Reducer housings, sizes 1 thru 5, must be drilled and tapped to accommodate seal. On sizes 6 and larger, the auxiliary seal bolts to the existing seal carrier, with the longer bolts supplied with the kit. A filter breather is included with each auxiliary seal kit.

AUXILIARY SEAL KITS ★ ■ ●

Reducer Size	Nominal Ratio	Part Number	Reducer Size	Nominal Ratio	Part Number
TXT1	9, 15, 25	272515	TXT6	5, 9, 15, 25	272450
	5	272521		TXT7	5, 9, 15, 25
TXT2	9, 15, 25	272446	TXT8		5, 15, 25
	5	272459		TXT9	5, 15, 26
TXT3A	9, 15, 25	243577	TXT10		15, 24
	5	253186		TXT12	15, 25
TXT4A	9, 15, 25	244676	TDT13		25
	5	254267		TDT14	25
TXT5B	9, 15, 25	245635	TDT15		30
TXT5A	5	255230			

★ For Taper Bushed reducers only.

■ See page G2-203 for dimensions to drill and tap reducer housing for mounting of auxiliary seal kit. Dodge will install upon request.

♣ Made to order

● Input auxiliary seal can not be used on same input shaft with a cooling fan



TORQUE-ARM Shaft Mount Speed Reducers

COOLING FAN ASSEMBLIES FOR TORQUE-ARM REDUCERS

When the thermal capacity of a Torque-Arm reducer is exceeded, cooling fans provide an optional, inexpensive way of lowering the oil temperature, thus increasing the thermal horsepower capacity of the reducer. Selection tables indicate when a cooling fan is required.

Installation is accomplished simply by attaching formed steel mounting straps to the reducer input shaft seal carrier. The fan assembly, which fastens to the input shaft, is compact enough to allow installation of the V-drive originally designed for the reducer. The fan housing is attached

to the outer edges of the straps, which are spaced to allow free circulation of air at the back of the housing as well as through the front of the unit. The fan blade offers a radial streamline air flow which means smaller fans yet a more efficient movement of air.

For thermal capacities beyond the range of cooling fans, heat exchangers may be used-see below.

NOTE: See page G2-205 for maximum input shaft speeds

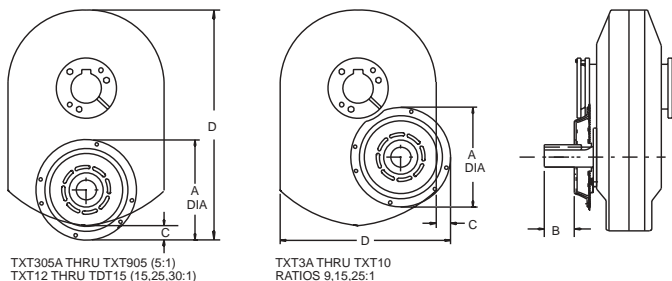

TORQUE-ARM REDUCER COOLING FAN ASSEMBLIES

REDUCER SIZE	COOLING FAN NO.	PART NUMBER	NOMINAL RATIOS	WT.	A	B	C	D
TXT3A, SCXT3A	TXT3A	243581	9, 15, 25	3.0	4.88	2.13	0.15	9.38
TXT305A, SCXT305A	TXT305A	253188	5	3.0	3.94	1.88	-	-
TXT4A, SCXT4A	TDT4	272594	9, 15, 25	3.0	5.88	2.94	0.50	10.88
TXT405A, SCXT405A	TXT405A	254268	5	3.0	4.68	2.94	-	-
TXT5B, SCXT5B	TDT5	272369	9, 15, 25	3.0	7.08	3.44	-	-
TXT505A, SCXT505A	TXT505A	255231	5	3.0	5.75	3.44	-	-
TXT6, SCXT6	TDT6	272325	9, 15, 25	6.0	10.25	3.44	1.31	16.44
TXT605, SCXT605	TXT605	272681 ♣	5	6.0	7.08	3.42	-	-
TXT7, SCXT7	TDT7	272326	9, 15, 25	6.0	12.75	3.68	2.18	20.94
TXT705, SCXT705	TXT705	272685 ♣	5	6.0	9.25	3.88	-	-
TXT8	TDT8	272327	15, 25	9.0	12.75	4.18	2.38	22.63
TXT805	TDT8	272327	5	9.0	12.75	4.25	-	-
TXT9	TDT9	272328	15, 26	15.0	16.75	6.31	3.75	26.38
TXT905	TDT9	272324 ♣	5	15.0	12.75	7.44	-	-
TXT10	TDT10	272329	15, 24	15.0	16.75	6.13	2.25	27.75
TXT12	TDT12	272330	15, 25	15.0	16.75	5.88	3.25	46.75
TDT13	TDT13	272331	25	20.0	18.50	5.68	3.94	49.75
TDT14	TDT14	272332	25	20.0	18.50	8.63	2.81	52.88
TDT15	TDT15	272333	30	23.0	18.50	9.50	2.00	60.63

♣ MADE TO ORDER

REDUCER HEAT EXCHANGER COOLING PACKAGE

For thermal capacities beyond the range of cooling fans, an optional heat exchanger cooling package is available to prevent overheating the reducer and allow the use of full mechanical HP rating by lowering the oil temperature to an acceptable level.

Specifications for the heat exchanger motor are as follows:
1/2 hp, 60 Hz, 3Ph. 230/460 Volt, TEFC, 56 Frame.
Minimum coolant (water) flow is 3 G.P.M. based upon a maximum water temperature of 80°F.
Minimum oil temperature for operation is 60°F.



Part Number

014148 ♣

♣ Made to order

FEATURES/BENEFITS
PAGE G2-3

NOMENCLATURE
PAGE G2-11

SELECTION/DIMENSIONS
PAGE G2-28

RELATED PRODUCTS
PAGE G2-152



Screw Conveyor Shaft Mount Speed Reducers EASY SELECTION METHOD (FOR ELECTRIC MOTORS)

When to Use Easy Selection

The Easy Selection tables for Shaft Mount reducers are for electric motor selections up to 75 horsepower with output speeds up to 400 RPM, using AGMA recommended application class numbers. For extreme shock or high energy loads which must be absorbed, as when stalling; for power source other than an electric motor; or for extreme ambient temperatures, or oversized equipment, consult DODGE Application Engineering, (864) 288-9050.

How to Select

Step 1: Determine Class of Service-See Table 1, page G2- 15 to determine Load Classification for applications under normal conditions. Find the type application and duty cycle that most closely matches your specific application.

Class I Steady load not exceeding Motor HP rating and light shock loads during 10 hours a day. Moderate shock loads are allowable if operation is intermittent.

For Class I applications, the maximum value of starting and momentary peak loads should not exceed 2 x Motor HP rating. If it exceeds this amount it should be divided by 2 and the result used in the selection table instead of the Motor HP rating.

Class II Steady load not exceeding Motor HP rating for over 10 hours a day. Moderate shock loads are allowable during 10 hours a day.

For Class II applications, the maximum value of starting and momentary peak loads should not exceed 2.8 x Motor HP rating. If it exceeds this amount it should be divided by 2.8 and the result

used in the selection table instead of the Motor HP rating.

Class III Moderate shock loads for over 10 hours a day. Heavy shock loads are allowable during 10 hours a day.

For Class III applications, the maximum value of starting and momentary peak loads should not exceed 4 x Motor HP rating. If it exceeds this amount it should be divided by 4 and the result used in the selection table instead of the Motor HP rating.

Step 2: Determine Reducer Size-See the Easy Selection Tables, pages G2- 83 thru G2- 88. From Selection Table I, II or III read the reducer size for the application horsepower and output speed. **Note:** For applications where fan cooling is unacceptable use the Easy Selection tables with an increased Class number. Where more than one reducer selection is listed, the most economical ratio is generally listed first. See page G2- 205 for maximum input and output speeds, overhung load ratings and WR2 ratings.

Step 3: Check Dimensions-See Selection/Dimensions sections, pages G2- 90 thru G2- 120 for reducer dimensions, weights and part numbers. See Engineering/Technical section, page G2- 199 and G2- 213 for reducer mounting positions.

Step 4: Select Screw Conveyor Drive Shaft and Adapter to fit screw diameter-See Selection/Dimensions section, pages G2- 90 thru G2- 120 for compatibility of screw diameter, drive shaft diameter and adapter.

FEATURES/BENEFITS PAGE G2- 3	NOMENCLATURE PAGE G2- 11	SELECTION/DIMENSIONS PAGE G2- 90	RELATED PRODUCTS PAGE G2- 152
---------------------------------	-----------------------------	-------------------------------------	----------------------------------

SELECTION



Screw Conveyor Shaft Mount Speed Reducers

Step 5: Select a Belt Drive Arrangement-From the Sheave Ratio table, page G2- 162, or the preselected 1750 RPM Motor V-drive tables, pages G2- 166 thru G2- 193 select the required sheave ratio for the belt drive. Select the belt drive so that the sheave mounted on the reducer shaft is not smaller than the minimum sheave diameter shown in Table 19, page G2- 161. **Note:** Mount the sheave as close as possible to the reducer to minimize the effect of overhung load on the reducer.

Step 6: Select Accessories-See Modifications/Accessories section, pages G2- 120 thru G2- 125, for description, dimensions, weights, and part numbers for

accessories available for the Screw Conveyor Drive reducer selected:

- Motor Mounts
- Belt Guards
- Cooling Fans
- Auxiliary Seal Kits
- Alternative drive shaft styles
- Filter Breathers

Note: Screw Conveyor Drive reducers are shipped without oil. Screw Conveyor Drive reducers are suitable from stock for vertical or incline mounting, no modification required.

EXAMPLE: Easy Selection Method-SCXT Screw Conveyor Drive Reducers

A 5 HP 1750 RPM motor is used to drive a heavy duty screw conveyor that runs 10 hours per day in a local feed mill, conveying grain. User needs a replacement reducer drive for a CEMA standard screw conveyor with a 12" diameter screw and 2-7/16, diameter drive shaft. Conveyor speed is 72 RPM.

Step 1: Determine Class of Service-From Table 1, locate "conveyors, general purpose; screw conveyor-heavy duty, not uniformly loaded" for 3 to 10 hours per day. This load is classified as a Class II application.

Step 2: Determine Reducer Size-From Table 10, Class II Selection, page G2- 86, find the column for 5 HP and read down to 72 RPM. An SCXT225 reducer is the correct selection. Check maximum input and output speed, overhung load, and WR2 requirements with reducer ratings on page G2- 205.

Step 3: Check Dimensions-See Selection/Dimensions section, page G2- 95, for reducer dimensions, weights, part numbers and other pertinent drive dimensions. See Engineering/Technical section, page G2- 199 and G2- 213 for information on mounting positions.

Step 4: Select Screw Conveyor Drive Shaft and Adapter to fit screw diameter-See Selection/Dimensions section,

page G2- 95. Here we verify that a 2-7/16" diameter drive shaft is compatible with 12" diameter screw. From this same page, select a C2B adapter with fits the 2-7/16" CEMA standard screw conveyor drive shaft, as well as the 2" and 3" drive shafts.

Step 5: Select a Belt Drive Arrangement-From the Sheave Ratio table, page G2- 162, or the Preselected 1750 RPM Motor V-Drive table for SCXT225 reducers, page G2- 166, select a V-drive ratio for the conveyor speed of 72 RPM. With this information, select a belt drive that meets your customer's needs-i.e. belt style preference, service factor requirements, Taper Lock or QD mounting, etc. Sheave diameter must not be less than minimum diameters shown in Table 19, page G2- 161.

Step 6: Select Accessories-See Selection/Dimensions page G2- 95 and Modifications/Accessories pages G2- 120 thru G2- 125 to pick out accessories for this application:

M214 Motor Mount-to mount motor to side of SCXT225 reducer.

SCXT2D Expanded Metal Belt Guard-to cover and protect the rotating belt drive.



Screw Conveyor Shaft Mount Speed Reducers

SELECTION GUIDE: SCXT SCREW CONVEYOR DRIVE REDUCERS

This Is A Handy Reference Sheet For Quick Selection And Specification Of DODGE Screw conveyor Drive Reducers. Use It To Identify Information Needed To Make An Accurate Selection With A Step-By-Step Selection Format For Choosing Reducer, Accessories And V-Drive

Use This Page To Make Your Own Selections Or Send This Form, With Application Data, To DODGE For Assistance. **You May Make Copies For Future Use.**

Name _____ Company Name _____
 Phone No. _____ Fax. No. _____

Application Data:

Type of Driven Equipment _____
 Hours of Service Per Day _____ Class of Service _____
 Type of Load: Uniform _____ Moderate _____ Shock _____
 Motor Type: HP _____ RPM _____ Frame Size _____ Shaft Size _____
 Screw Conveyor RPM _____ Screw Diameter _____
 Drive Shaft Diameter And Type _____
 Adapter Type _____
 Unusual Ambient Temperature _____
 Other Pertinent Application Characteristics (i.e.-dusty Environment, Reversing Duty, Start/Stop Cycles, Etc.) _____

Reducer Drive Selection

Step 1 - Determine Class Of Service _____
Step 2 - From Appropriate Service Class Table, Select Reducer Size And Ration That Meets Application HP And Driven RPM Requirements: _____
Step 3 - Select Drive Shaft With Diameter To Fit Screw Size _____
 Determine Type Of Drive Shaft Needed: Standard _____ Stainless Steel _____
 3-Hole Standard _____ 3-Hole Stainless _____
Step 4 - Select Adapter: "C" Standard _____
 "AC" Adjustable Packing Gland _____
Step 5 - Select Accessories Required For Application:
 Motor Mount: Standard _____ Long _____
 Belt Guard: Standard _____ Long _____
 Cooling Fan _____ Auxiliary Seal Kit _____ Filter Breather _____
 Other _____

V-Belt Drive Specification:

Service Factor _____ V-Belt Drive Ratio Needed _____
 Belt Center Distance _____ Type Of Belt Desired _____
 Driver: Shaft Diameter _____ Driven: Shaft Diameter _____
 Sheave _____ Sheave _____
 Bushing _____ Bushing _____
 Belts: Size _____ Quantity _____

FEATURES/BENEFITS PAGE G2- 3	NOMENCLATURE PAGE G2- 11	SELECTION/DIMENSIONS PAGE G2- 90	RELATED PRODUCTS PAGE G2- 152
---------------------------------	-----------------------------	-------------------------------------	----------------------------------

EASY SELECTION



Screw Conveyor Shaft Mount Speed Reducers

Table 9 - CLASS I SELECTOIN TABLE SCXT REDUCERS ★

HP	OUTPUT RPM	REDUCER SELECTION	
		SINGLE	DOUBLE
1/4	4-70		SCXT125 SCXT115
	71-85		SCXT115 SCXT125
	86-115		SCXT115 SCXT109
	116-140	SCXT105	SCXT109 SCXT115
	141-200	SCXT105	SCXT109
	201-400	SCXT105	
1/3	5-70		SCXT125 SCXT115
	71-85		SCXT115 SCXT125
	86-115		SCXT115 SCXT109
	116-140	SCXT105	SCXT109 SCXT115
	141-200	SCXT105	SCXT109
	201-400	SCXT105	
1/2	4-6		SCXT225
	7-70		SCXT125 SCXT115
	71-85		SCXT115 SCXT125
	86-115		SCXT115 SCXT109
	116-140	SCXT105	SCXT109 SCXT115
	141-200	SCXT105	SCXT109
3/4	4-5		SCXT325A
	6-10		SCXT225
	11-70		SCXT125 SCXT115
	71-85		SCXT115 SCXT125
	86-115		SCXT115 SCXT109
	116-140	SCXT105	SCXT109 SCXT115
1	4-5		SCXT425A
	6-7		SCXT325A
	8-15		SCXT225
	16-70		SCXT125 SCXT115
	71-85		SCXT115 SCXT125
	86-115		SCXT115 SCXT109
1-1/2	4		SCXT525B
	5-7		SCXT425A
	8-12		SCXT325A
	13-23		SCXT225
	24-70		SCXT125 SCXT115
	71-85		SCXT115 SCXT125
2	4-6		SCXT625
	6-10		SCXT525B
	11-15		SCXT425A
	16-26		SCXT325A
	27-51		SCXT225 SCXT215
	52-70		SCXT125 SCXT115
3	71-85		SCXT115 SCXT125
	86-115		SCXT115 SCXT109
	116-140	SCXT105	SCXT109 SCXT115
	141-200	SCXT105	SCXT109
	201-400	SCXT105	
	5	5-6	
7-9			SCXT625
10-17			SCXT525B
18-26			SCXT425A SCXT415A
27-46			SCXT325A SCXT315A
47-70			SCXT225 SCXT215
7-1/2	71-85		SCXT215 SCXT225
	86-92		SCXT109 SCXT215
	93-115		SCXT115 SCXT109
	116-119		SCXT109 SCXT115
	120-140	SCXT105	SCXT109 SCXT115
	141-200	SCXT105	SCXT109
7-1/2	201-400	SCXT105	
	4-6		SCXT825
	7-9		SCXT725
	10-15		SCXT625
	16-26		SCXT525B
	27-40		SCXT425A SCXT415A
7-1/2	41-70		SCXT325A SCXT315A
	71-74		SCXT315A SCXT325A
	75-85		SCXT215 SCXT225
	86-95		SCXT215 SCXT209
	96-140	SCXT205	SCXT209 SCXT215
	141-200	SCXT205	SCXT209
7-1/2	201-231	SCXT205	
	232-400	SCXT205	

★ See page G2- 199 for lubrication for 15 RPM and slower.

FEATURES/BENEFITS
PAGE G2- 3

NOMENCLATURE
PAGE G2- 11

SELECTION/DIMENSIONS
PAGE G2- 90

RELATED PRODUCTS
PAGE G2- 152



Screw Conveyor Shaft Mount Speed Reducers

Table 9 - CLASS I SELECTOIN TABLE SCXT REDUCERS ★ (CONT'D)

HP	OUTPUT RPM	REDUCER SELECTION		
		SINGLE	DOUBLE	
10	6-8		SCXT825	
	9-12		SCXT725	
	13-20		SCXT625	
	21-36		SCXT525B SCXT515B	
	37-56		SCXT425A SCXT415A	
	57-70		SCXT325A SCXT315A	
	71-85		SCXT315A SCXT325A	
	86-103		SCXT315A SCXT309A	
	104-115		SCXT215 SCXT209	
	116-140	SCXT305A	SCXT215	
	141-158	SCXT305A	SCXT309A	
	159-200	SCXT305A	SCXT309A	
	201-400	SCXT205		
15	9-13		SCXT825	
	14-19		SCXT725	
	20-32		SCXT625 SCXT615	
	33-56		SCXT525B SCXT515B	
	57-70		SCXT425A SCXT415A	
	71-85		SCXT415A SCXT425A	
	86-93		SCXT415A SCXT409A	
	94-115		SCXT309A+ SCXT315A	
	116-140	SCXT405A	SCXT315A SCXT309A+	
	141-145	SCXT405A	SCXT309A+	
	146-200	SCXT305A	SCXT309A+	
	201-400	SCXT305A		
	20	13-18		SCXT825
19-26			SCXT725 SCXT715	
27-45			SCXT625 SCXT615	
46-70			SCXT525B SCXT515B	
71-78			SCXT515B SCXT525B	
79-85			SCXT415A SCXT425A	
86-115			SCXT415A SCXT409A+	
116-140		SCXT405A	SCXT409A+ SCXT415A+	
141-200		SCXT405A	SCXT309A+	
201-241		SCXT405A		
242-400		SCXT305A+		
25		16-23		SCXT825
		24-33		SCXT725 SCXT715
	34-59		SCXT625 SCXT615	
	60-70		SCXT525B+ SCXT515B+	
	71-80		SCXT515B+ SCXT525B+	
	81-101		SCXT515B+ SCXT509B+	
	102-132	SCXT505A	SCXT415A+ SCXT409A+	
	133-140	SCXT505A	SCXT409A+ SCXT415A+	
	141-163	SCXT505A	SCXT409A+	
	164-200	SCXT405A+	SCXT409A+	
	201-400	SCXT405A+		

HP	OUTPUT RPM	REDUCER SELECTION		
		SINGLE	DOUBLE	
30	20-28		SCXT825 SCXT815	
	29-41		SCXT725 SCXT715	
	42-70		SCXT625 SCXT615	
	71-75		SCXT615 SCXT625	
	76-115		SCXT515B+ SCXT509B+	
	116-125	SCXT605	SCXT509B+ SCXT515B+	
	126-131	SCXT605	SCXT409A+	
	132-200	SCXT505A	SCXT409A+	
	201-215	SCXT505A+		
	216-400	SCXT405A+		
	40	26-38		SCXT825 SCX815
		39-57		SCXT725 SCXT715
		58-70		SCXT625 SCXT615
71-81			SCXT615+ SCXT625+	
82-114		SCXT605	SCXT615+ SCXT609+	
115-125		SCXT605	SCXT515B+ SCXT509B+	
126-200		SCXT605	SCXT509B+	
201-241		SCXT605		
242-400		SCXT505A+		
50		33-49		SCXT825 SCXT815
		50-70		SCXT725 SCXT715
		71-74		SCXT715 SCXT725
		75-125		SCXT615+ SCXT709+
	126-163	SCXT605+	SCXT709+	
	164-200	SCXT605+	SCXT609+	
	201-400	SCXT605+		
	60	40-60		SCXT825 SCXT815
		61-70		SCXT725+ SCXT715+
		71-120		SCXT715+ SCXT709+
		121-131	SCXT705	SCXT709+
		132-200	SCXT605+	SCXT709+
		201-400	SCXT605+	
75	51-70		SCXT825 SCXT815	
	71-78		SCXT815+	
	79-120		SCXT715+ SCXT709+	
	121-200	SCXT705	SCXT709+	
	201-210	SCXT705		
211-400	SCXT605+			

★ See page G2- 199 for lubrication for 15 RPM and slower

+ Fan cooling required - see page G2- 80

FEATURES/BENEFITS PAGE G2- 3	NOMENCLATURE PAGE G2- 11	SELECTION/DIMENSIONS PAGE G2- 90	RELATED PRODUCTS PAGE G2- 152
---------------------------------	-----------------------------	-------------------------------------	----------------------------------



EASY SELECTION

Screw Conveyor Shaft Mount Speed Reducers

Table 10 - CLASS II SELECTOIN TABLE SCXT REDUCERS ★

HP	OUTPUT RPM	REDUCER SELECTION	
		SINGLE	DOUBLE
1/4	5-70		SCXT125 SCXT115
	71-85		SCXT115 SCXT125
	86-115		SCXT115 SCXT109
	116-140	SCXT105	SCXT109 SCXT115
	141-200	SCXT105	SCXT109
	201-400	SCXT105	
1/3	4-6		SCXT225
	7-70		SCXT125 SCXT115
	71-85		SCXT115 SCXT125
	86-115		SCXT115 SCXT109
	116-140	SCXT105	SCXT109 SCXT115
	141-200	SCXT105	SCXT109
201-400	SCXT105		
1/2	4-5		SCXT325A
	6-9		SCXT225
	10-70		SCXT125 SCXT115
	71-85		SCXT115 SCXT125
	86-115		SCXT115 SCXT109
	116-140	SCXT105	SCXT109 SCXT115
141-200	SCXT105	SCXT109	
201-400	SCXT105		
3/4	4-5		SCXT425A
	6-8		SCXT325A
	9-16		SCXT225
	17-70		SCXT125 SCXT115
	71-85		SCXT115 SCXT125
	86-115		SCXT115 SCXT109
116-140	SCXT105	SCXT109 SCXT115	
141-200	SCXT105	SCXT109	
201-400	SCXT105		
1	5-7		SCXT425A
	8-11		SCXT325A
	12-22		SCXT225
	23-70		SCXT125 SCXT115
	71-85		SCXT115 SCXT125
	86-115		SCXT115 SCXT109
116-140	SCXT105	SCXT109 SCXT115	
141-200	SCXT105	SCXT109	
201-400	SCXT105		
1-1/2	5-6		SCXT525B
	7-11		SCXT425A
	12-18		SCXT325A
	19-34		SCXT225 SCXT215
	35-70		SCXT125 SCXT115
	71-85		SCXT115 SCXT125
86-115		SCXT115 SCXT109	
116-140	SCXT105	SCXT109 SCXT115	
141-200	SCXT105	SCXT109	
201-400	SCXT105		
2	4-5		SCXT625
	6-9		SCXT525B
	10-14		SCXT425A
	15-24		SCXT325A SCXT315A
	25-47		SCXT225 SCXT215
	48-70		SCXT125 SCXT115
	71-85		SCXT115 SCXT125
	86-115		SCXT115 SCXT109
	116-140	SCXT105	SCXT109 SCXT115
	141-200	SCXT105	SCXT109
201-400	SCXT105		
3	4-5		SCXT725
	6-8		SCXT625
	9-14		SCXT525B
	15-22		SCXT425A SCXT415A
	23-38		SCXT325A SCXT315A
	39-70		SCXT225 SCXT215
	71-75		SCXT215 SCXT225
	76-85		SCXT115 SCXT125
	86-115		SCXT115 SCXT109
	116-140	SCXT105	SCXT109 SCXT115
141-200	SCXT105	SCXT109	
201-400	SCXT105		
5	4-6		SCXT825
	7-8		SCXT725
	9-14		SCXT625
	15-24		SCXT525B
	25-37		SCXT425A SCXT415A
	38-69		SCXT325A SCXT315A
	70-85		SCXT215 SCXT225
	86-89		SCXT215 SCXT209
	90-136	SCXT205	SCXT209 SCXT215
	137-140	SCXT205	SCXT115 SCXT209
141-191	SCXT205	SCXT109	
192-200	SCXT105	SCXT109	
201-400	SCXT105		
7-1/2	6-9		SCXT825
	10-13		SCXT725
	14-21		SCXT625
	22-38		SCXT525B SCXT515B
	39-59		SCXT425A SCXT415A
	60-70		SCXT325A SCXT315A
71-85		SCXT315A SCXT325A	
86-110		SCXT315A SCXT309A	
111-122		SCXT215	

★ See page G2- 199 for lubrication for 15 RPM and slower



Screw Conveyor Shaft Mount Speed Reducers

Table 10 - CLASS II SELECTOIN TABLE SCXT REDUCERS ★ (CONT'D)

HP	OUTPUT RPM	REDUCER SELECTION	
		SINGLE	DOUBLE
7-1/2	123-140	SCXT305A	SCXT209 SCXT215
	141-183	SCXT305A	SCXT209
	184-200	SCXT205	SCXT209
	201-400	SCXT205	
10	8-12		SCXT825
	13-18		SCXT725
	19-29		SCXT625 SCXT615
	30-52		SCXT525B SCXT515B
	53-70		SCXT425A SCXT415A
	71-84		SCXT415A SCXT425A
	85-130		SCXT315A SCXT309A
	131-140	SCXT305A	SCXT315A SCXT309A
	141-200	SCXT305A	SCXT309A
	201-353	SCXT305A	
	354-400	SCXT205	
	15	13-19	
20-27			SCXT725
28-47			SCXT625 SCXT615
48-70			SCXT525B SCXT515B
71-82			SCXT515B SCXT525B
83-117			SCXT415A SCXT409A
118-140		SCXT405A	SCXT409A SCXT415A
141-150		SCXT405A	SCXT409A
151-200		SCXT405A	SCXT309A+
201-269		SCXT405A	
270-400		SCXT305A	
20		18-26	
	27-38		SCXT725 SCXT715
	39-68		SCXT625 SCXT615
	69-80		SCXT515B SCXT525B
	81-89		SCXT515B
	90-117		SCXT515B+ SCXT509B+
	118-125	SCXT505A	SCXT409A+ SCXT415A+
	126-200	SCXT505A	SCXT409A+
25	201-400	SCXT405A+	
	23-33		SCXT825 SCXT815
	34-49		SCXT725 SCXT715
	50-80		SCXT615 SCXT625
	81-94		SCXT615 SCXT609
	95-125	SCXT605	SCXT509B+ SCXT515B+
	126-174	SCXT605	SCXT509B+
	175-200	SCXT505A	SCXT409A+
	201-270	SCXT505A	
	271-400	SCXT405A+	

HP	OUTPUT RPM	REDUCER SELECTION		
		SINGLE	DOUBLE	
30	28-41		SCXT825 SCXT815	
	42-60		SCXT725 SCXT715	
	61-76		SCXT625 SCXT615	
	77-89		SCXT615 SCXT609	
	90-125	SCXT605	SCXT615+ SCXT609+	
	126-200	SCXT605	SCXT509B+	
	201-233	SCXT605		
	234-349	SCXT505A+		
40	350-400	SCXT405A+		
	37-56		SCXT825 SCXT815	
	57-75		SCXT725 SCXT715	
	76-88		SCXT715	
	89-114		SCXT615+ SCXT609+	
	115-120		SCXT615+ SCXT609+	
	121-200	SCXT605	SCXT609+	
	201-347	SCXT605+		
	348-400	SCXT505A+		
	50	47-70		SCXT825 SCXT815
71-72			SCXT815 SCXT825	
73-95			SCXT715+	
96-110		SCXT705	SCXT709 SCXT715+	
111-120		SCXT705	SCXT709+ SCXT715+	
121-179		SCXT705	SCXT709+	
180-200		SCXT605	SCXT609+	
201-400		SCXT605+		
60		57-70		SCXT825 SCXT815
		71-75		SCXT815 SCXT825
	76-89		SCXT815	
	90-120	SCXT705	SCXT715+ SCXT709+	
	121-200	SCXT705	SCXT709+	
	201-285	SCXT705		
	286-400	SCXT605+		
	75	74-75		SCXT815 SCXT825
76-120			SCXT815+	
121-133			SCXT709+	
134-200		SCXT705	SCXT709+	
201-400		SCXT705		

★ See page G2- 199 for lubrication for 15 RPM and slower

+ Fan cooling required - see page G2- 80

FEATURES/BENEFITS PAGE G2- 3	NOMENCLATURE PAGE G2- 11	SELECTION/DIMENSIONS PAGE G2- 90	RELATED PRODUCTS PAGE G2- 152
---------------------------------	-----------------------------	-------------------------------------	----------------------------------

EASY SELECTION



Screw Conveyor Shaft Mount Speed Reducers

Table 11 - CLASS III SELECTOIN TABLE SCXT REDUCERS ★

HP	OUTPUT RPM	REDUCER SELECTION		
		SINGLE	DOUBLE	
1/4	4-6	SCXT225		
	7-70	SCXT125	SCXT115	
	71-85	SCXT115	SCXT125	
	86-89	SCXT115	SCXT109	
	90-115	SCXT115	SCXT109	
	116-140	SCXT105	SCXT109	
	141-200	SCXT105	SCXT109	
	201-400	SCXT105		
1/3	5-9	SCXT225		
	10-70	SCXT125	SCXT115	
	71-85	SCXT115	SCXT125	
	86-115	SCXT115	SCXT109	
	116-140	SCXT105	SCXT109	
	141-200	SCXT105	SCXT109	
	201-400	SCXT105		
1/2	4-5	SCXT425A		
	6-7	SCXT325A		
	8-15	SCXT225		
	16-70	SCXT125	SCXT115	
	71-85	SCXT115	SCXT125	
	86-115	SCXT115	SCXT109	
	116-140	SCXT105	SCXT109	
	141-200	SCXT105	SCXT109	
	201-400	SCXT105		
	3/4	4	SCXT525B	
5-7		SCXT425A		
8-12		SCXT325A		
13-23		SCXT225		
24-70		SCXT125	SCXT115	
71-85		SCXT115	SCXT125	
86-115		SCXT115	SCXT109	
116-140		SCXT105	SCXT109	
141-200		SCXT105	SCXT109	
201-400		SCXT105		
1		4-6	SCXT525B	
		7-10	SCXT425A	
		11-17	SCXT325A	
		18-32	SCXT225	
	33-70	SCXT125	SCXT115	
	71-85	SCXT115	SCXT125	
	86-115	SCXT115	SCXT109	
	116-140	SCXT105	SCXT109	
	141-200	SCXT105	SCXT109	
	201-400	SCXT105		
	1-1/2	4-5	SCXT625	
6-10		SCXT525B		
1-1/2	11-15	SCXT425A		
	16-26	SCXT325A		
	27-51	SCXT225	SCXT215	
	52-70	SCXT125	SCXT115	
	71-85	SCXT115	SCXT125	
	86-115	SCXT115	SCXT109	
	116-140	SCXT105	SCXT109	
	141-200	SCXT105	SCXT109	
	201-400	SCXT105		
	2	5-7	SCXT625	
		8-13	SCXT525B	
14-21		SCXT425A		
22-36		SCXT325A	SCXT315A	
37-71		SCXT225	SCXT215	
72-85		SCXT115	SCXT125	
86-115		SCXT115	SCXT109	
116-140		SCXT105	SCXT109	
141-200		SCXT105	SCXT109	
201-400		SCXT105		
3	4-5	SCXT825		
	6-7	SCXT725		
	8-12	SCXT625		
	13-20	SCXT525B		
	21-32	SCXT425A	SCXT415A	
	33-57	SCXT325A	SCXT315A	
	58-70	SCXT225	SCXT215	
	71-85	SCXT215	SCXT225	
	86-89	SCXT215	SCXT209	
	90-113	SCXT205	SCXT215	
	114-140	SCXT205	SCXT109	
	141-155	SCXT205	SCXT109	
	156-200	SCXT105	SCXT109	
	201-400	SCXT105		
5	6-8	SCXT825		
	9-12	SCXT725		
	13-20	SCXT625		
	21-36	SCXT525B	SCXT515B	
	37-56	SCXT425A	SCXT415A	
	57-70	SCXT325A	SCXT315A	
	71-85	SCXT315A	SCXT325A	
	86-103	SCXT315A	SCXT309A	
	104-114	SCXT305A	SCXT215	
	115-140	SCXT305A	SCXT209	
	141-167	SCXT305A	SCXT209	
	168-200	SCXT205	SCXT209	
	201-400	SCXT205		

★ See page G2- 199 for lubrication for 15 RPM and slower

FEATURES/BENEFITS
PAGE G2- 3

NOMENCLATURE
PAGE G2- 11

SELECTION/DIMENSIONS
PAGE G2- 90

RELATED PRODUCTS
PAGE G2- 152



Screw Conveyor Shaft Mount Speed Reducers

Table 11 - CLASS III SELECTOIN TABLE SCXT REDUCERS ★ (CONT'D)

HP	OUTPUT RPM	REDUCER SELECTION	
		SINGLE	DOUBLE
7-1/2	9-13		SCXT825
	14-19		SCXT725
	20-32		SCXT625 SCXT615
	33-56		SCXT525B SCXT515B
	57-70		SCXT425A SCXT415A
	71-85		SCXT415A SCXT425A
	86-93		SCXT415A SCXT409A
	94-140	SCXT405A	SCXT309A SCXT315A
	141-144	SCXT405A	SCXT309A
	145-200	SCXT305A	SCXT309A
201-400	SCXT305A		
10	13-18		SCXT825
	19-26		SCXT725 SCXT715
	27-45		SCXT625 SCXT615
	46-70		SCXT525B SCXT515B
	71-78		SCXT515B SCXT525B
	79-92		SCXT415A
	93-105		SCXT415A SCXT409A
	106-141	SCXT405A	SCXT409A SCXT415A
	142-200	SCXT405A	SCXT309A
	201-241	SCXT405A	
242-400	SCXT305A		
15	20-28		SCXT825 SCXT815
	29-41		SCXT725 SCXT715
	42-70		SCXT625 SCXT615
	71-75		SCXT615 SCXT625
	76-93		SCXT515B
	94-115		SCXT515B SCXT509B
	116-125	SCXT605	SCXT509B SCXT515B
	126-131	SCXT605	SCXT509B
	132-200	SCXT505A	SCXT409A
	201-215	SCXT505A	
216-400	SCXT405A		
20	26-38		SCXT825 SCXT815
	39-57		SCXT725 SCXT715
	58-70		SCXT625 SCXT615
	71-114		SCXT615 SCXT609
	115-125	SCXT605	SCXT509B+ SCXT515B+
	126-200	SCXT605	SCXT509B+
	201-218	SCXT605	
	219-324	SCXT505A	
	325-400	SCXT405A+	

HP	OUTPUT RPM	REDUCER SELECTION		
		SINGLE	DOUBLE	
25	33-49		SCXT825 SCXT815	
	50-70		SCXT725 SCXT715	
	71-74		SCXT715 SCXT725	
	75-104		SCXT615 SCXT609	
	105-113		SCXT615+ SCXT609	
	114-125	SCXT605	SCXT615+ SCXT609+	
	126-200	SCXT605	SCXT609+	
	201-294	SCXT605		
	295-400	SCXT505A+		
	30	40-60		SCXT825 SCXT815
61-70			SCXT725 SCXT715	
71-98			SCXT715	
99-125			SCXT615 SCXT609+	
126-131		SCXT705	SCXT609+	
132-200		SCXT605	SCXT609+	
201-381		SCXT605		
382-400		SCXT505A+		
40		54-70		SCXT825 SCXT815
		71-84		SCXT815
	85-89		SCXT715 SCXT709	
	90-120	SCXT705	SCXT715+ SCXT709	
	121-200	SCXT705	SCXT709+	
	201-249	SCXT705		
	250-400	SCXT605+		
	50	70-75		SCXT815 SCXT825
		76-110		SCXT815
		111-120		SCXT715+ SCXT709+
121-123			SCXT709+	
124-200		SCXT705	SCXT709+	
201-400		SCXT705		
60		86-120		SCXT815
	142-161		SCXT709+	
	162-200	SCXT705	SCXT709+	
	201-400	SCXT705		

★ See page G2- 199 for lubrication for 15 RPM and slower

+ Fan cooling required - see page G2- 80

FEATURES/BENEFITS PAGE G2- 3	NOMENCLATURE PAGE G2- 11	SELECTION/DIMENSIONS PAGE G2- 90	RELATED PRODUCTS PAGE G2- 152
---------------------------------	-----------------------------	-------------------------------------	----------------------------------

SELECTION/DIMENSIONS



Screw Conveyor Shaft Mount Speed Reducers SCXT1 - DOUBLE REDUCTION SCREW CONVEYOR DRIVES

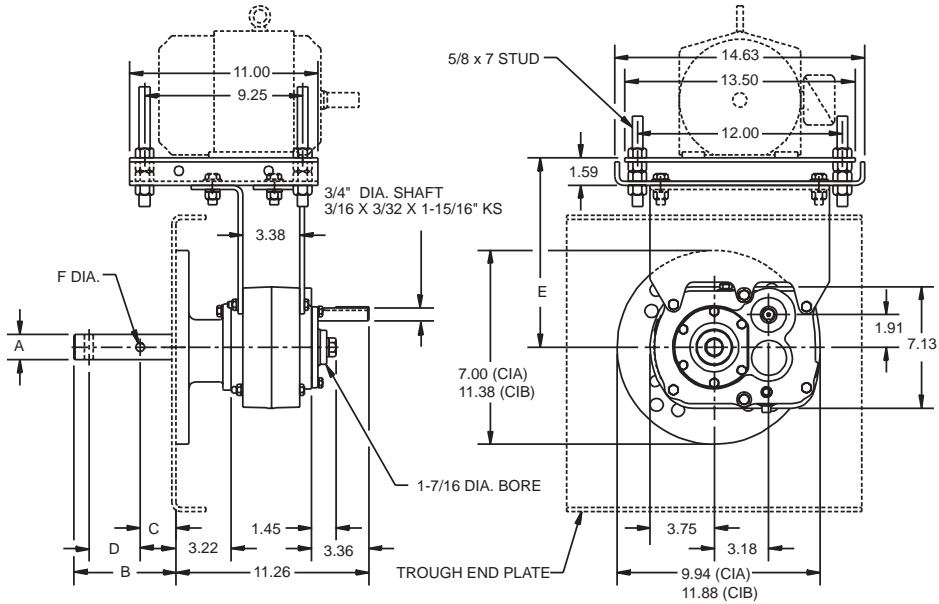

SCXT1 Screw Conveyor Drives †

Reducers				
Size	Part No.	AGMA Code	Ratio	Weight
SCXT109	241480	107D09	9.44	45
SCXT115	351163	107D15	15.35	45
SCXT125	351164	107D25	25.64	45

CEMA Drive Shafts ★									Adapter Assembly ▲		
Drive Shaft	Screw Dia.	Part No.	A	B	C	D	F Dia.	Weight	Size	Part No.	Weight
C1 x 1-1/2	6" - 9"	351094	1.50	6.00	2.13	3.00	.52	7.2	C1A	351086	13
									AC1B ♠	356168	22
C1 x 2	9" - 12'	351095	2.00	6.00	2.13	3.00	.64	9.1	C1B	351087	27
C1 x 2-7/16	12" - 1'4"	351096	2.44	6.69	2.75	3.00	.64	12.5	AC1B ♠	356168	22
C1 x 3	12" - 20"	351097	3.00	6.88	2.88	3.00	.77	17.4			

FEATURES/BENEFITS PAGE G2-3	NOMENCLATURE PAGE G2-11	SELECTION PAGE G2-81	RELATED PRODUCTS PAGE G2-152
--------------------------------	----------------------------	-------------------------	---------------------------------



Screw Conveyor Shaft Mount Speed Reducers SCXT1 - DOUBLE REDUCTION SCREW CONVEYOR DRIVES

SCXT1 Accessories

Description	NEMA Motor Frame	Screw Dia.	Part No.	Weight
M112 Standard Motor Mount	56T thru 210T	6"-12"	351069	42
M120L Long Motor Mount	56T thru 210T	14"-20"	272625	51
SCXT1-D SCD Reducer Belt Guard	56T thru 210T	-	241489	27
SCXT1-D SCD Reducer Belt Guard for Long Motor Mount	56T thru 210T	-	241149	32
SCXT1 Auxiliary Seal Kit ♥	-	-	272721	2

SCXT1 Motor Mount Assembly Dimensions

Motor Mount	E ♦		V-Belt Drive Center Distances for Various NEMA Motor Frames					
			56, 140		180		210	
	Min.	Max.	Min.	Max.	Min.	Max.	Min.	Max.
M112	11.10	15.30	13.50	17.00	14.50	18.00	15.30	19.00
M120L	17.10	21.30	19.50	22.90	20.50	23.90	21.20	24.70

† Complete drive consists of reducer, CEMA drive shaft and key, and adapter assembly. Drive is shipped unassembled.

- ♣ AC adjustable packing adapter furnished if specified. C-style adapter is standard.
- ◆ Provides for V-Belt adjustment.
- ♥ See page G2-201 for drill and tap information required to mount to reducer.

▲ Includes adapter, necessary mounting bolts, and seal retainer. Both lip type and braided type seals included for customer's choice of application.

- ★ CEMA drive shaft and key is furnished unless otherwise specified. See pages G2-120 thru G2-122 for optional drive shafts available from DODGE.

SELECTION/DIMENSIONS



Screw Conveyor Shaft Mount Speed Reducers SCXT105 - SINGLE REDUCTION SCREW CONVEYOR DRIVES

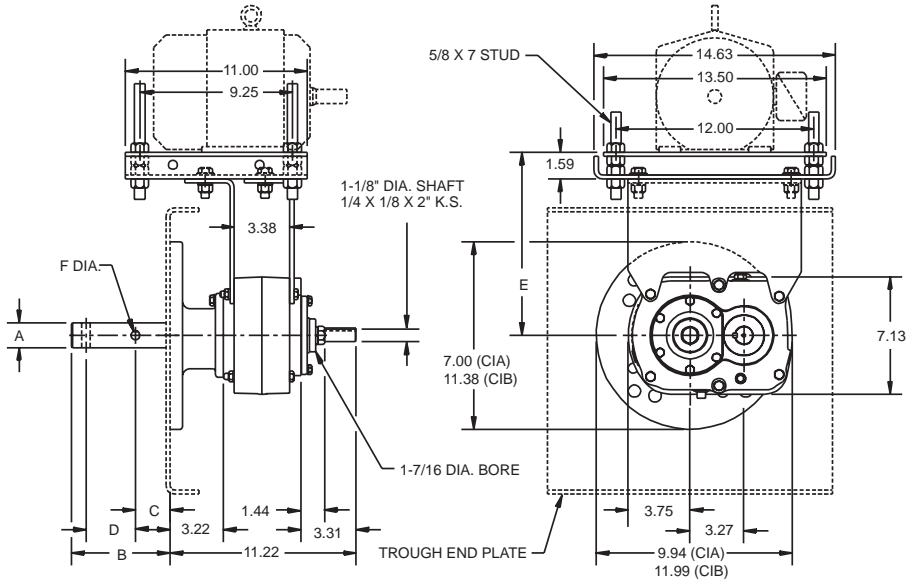

SCXT105 Screw Conveyor Drive †

Reducers				
Size	Part No.	AGMA Code	Ratio	Weight
SCXT105	351165	107S05	5.62	40

CEMA Drive Shafts ★									Adapter Assembly ▲		
Drive Shaft	Screw Dia.	Part No.	A	B	C	D	F Dia.	Weight	Size	Part No.	Weight
C1 x 1-1/2	6" - 9"	351094	1.50	6.00	2.13	3.00	.52	7.20	C1A	351086	13
									AC1B ♠	356168	22
C1 x 2	9" - 12"	351095	2.00	6.00	2.13	3.00	.64	9.10	C1B	351087	27
C1 x 2-7/16	12" - 1'4"	351096	2.44	6.69	2.75	3.00	.64	12.50	AC1B ♠	356168	22
C1 x 3	12" - 20"	351097	3.00	6.88	2.88	3.00	.77	17.40			

FEATURES/BENEFITS PAGE G2-3	NOMENCLATURE PAGE G2-11	SELECTION PAGE G2-81	RELATED PRODUCTS PAGE G2-152
--------------------------------	----------------------------	-------------------------	---------------------------------



Screw Conveyor Shaft Mount Speed Reducers SCXT105 - SINGLE REDUCTION SCREW CONVEYOR DRIVES

SCXT105 Accessories

Description	NEMA Motor Frame	Screw Dia.	Part No.	Weight
M112 Standard Motor Mount	56T thru 210T	6" - 12"	351069	42
M120L Long Motor Mount	56T thru 210T	14" - 20"	272625	51
SCXT1-S SCD Reducer Belt Guard	56T thru 210T	-	241491	30
SCXT1-S SCD Reducer Belt Guard for Long Motor Mount	56T thru 210T	-	241142	36
SCXT105 Auxiliary Seal Kit ♥	-	-	251146	2

SCXT105 Motor Mount Assembly Dimensions

Motor Mount	E ♦		V-Belt Drive Center Distances for Various NEMA Motor Frames					
			56, 140		180		210	
	Min.	Max.	Min.	Max.	Min.	Max.	Min.	Max.
M112	11.10	15.30	15.40	19.00	16.40	20.00	17.20	20.60
M120L	17.10	21.30	21.40	24.80	22.40	25.80	23.10	26.60

† Complete drive consists of reducer, CEMA drive shaft and key, and adapter assembly. Drive is shipped unassembled.

- ♣ AC adjustable packing adapter furnished if specified. C-style adapter is standard.
- ◆ Provides for V-Belt adjustment.
- ♥ See page G2-201 for drill and tap information required to mount to reducer.

▲ Includes adapter, necessary mounting bolts, and seal retainer. Both lip type and braided type seals included for customer's choice of application.

- ★ CEMA drive shaft and key is furnished unless otherwise specified. See pages G2-120 thru G2-122 for optional drive shafts available from DODGE.



SELECTION/DIMENSIONS

Screw Conveyor Shaft Mount Speed Reducers SCXT2 - DOUBLE REDUCTION SCREW CONVEYOR DRIVES

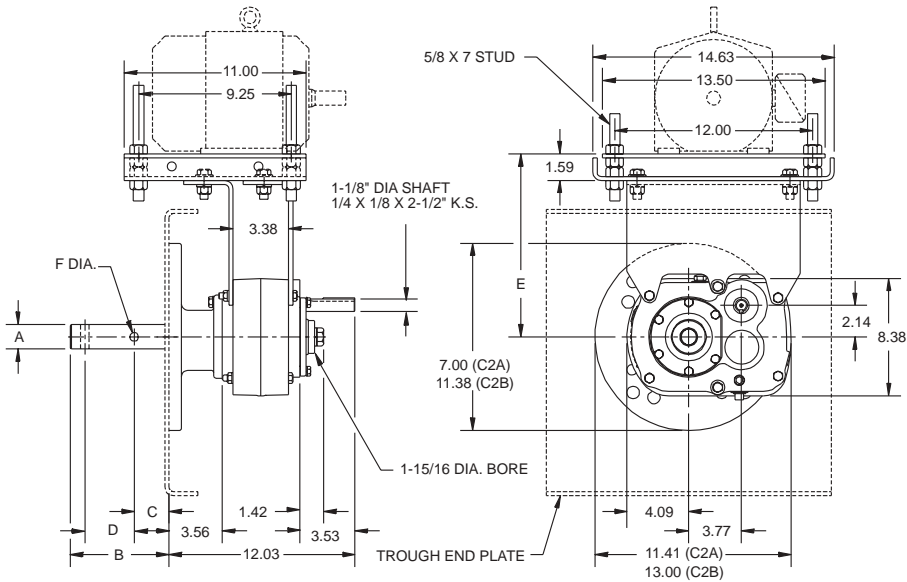

SXCT2 Screw Conveyor Drive †

Reducers				
Size	Part No.	AGMA Code	Ratio	Weight
SCXT209	242480	115D09	9.25	58
SCXT215	352065	115D15	14.10	58
SCXT225	352066	115D25	23.46	58

CEMA Drive Shafts ★									Adapter Assembly ▲		
Drive Shaft	Screw Dia.	Part No.	A	B	C	D	F Dia.	Weight	Size	Part No.	Weight
C2 x 1-1/2	6" - 9"	352090	1.50	6.00	2.13	3.00	.52	11.40	C2A	352052	15
									AC2B ♣	356112	25
C2 x 2	9" - 12"	352091	2.00	6.00	2.13	3.00	.64	13.80	C2B	352053	26
C2 x 2-7/16	12" - 1'4"	352092	2.44	6.69	2.75	3.00	.64	17.30	AC2B ♣	356112	25
C2 x 3	12" - 20"	352093	3.00	6.88	2.88	3.00	.77	19			



Screw Conveyor Shaft Mount Speed Reducers SCXT2 - DOUBLE REDUCTION SCREW CONVEYOR DRIVES

SCXT2 Accessories

Description	NEMA Motor Frame	Screw Dia.	Part No.	Weight
M214 Standard Motor Mount	56T thru 210T	6" - 14"	352069	43
M220L Long Motor Mount	56T thru 210T	16" - 20"	272626	51
SCXT2-D SCD Reducer Belt Guard	56T thru 210T	-	242489	32
SCXT2-D SCD Reducer Belt Guard for Long Motor Mount	56T thru 210T	-	242223	38
SCXT2 Auxiliary Seal Kit ♥	-	-	272722	3

SCXT2 Motor Mount Assembly Dimensions

Motor Mount	E ♦		V-Belt Drive Center Distances for Various NEMA Motor Frames					
			56, 140		180		210	
	Min.	Max.	Min.	Max.	Min.	Max.	Min.	Max.
M214	12.6	16.8	14.9	18.3	15.9	19.3	16.6	20.0
M220L	18.6	22.8	20.9	24.2	21.9	25.3	22.6	26.0

† Complete drive consists of reducer, CEMA drive shaft and key, and adapter assembly. Drive is shipped unassembled.

- ♣ AC adjustable packing adapter furnished if specified. C-style adapter is standard.
- ◆ Provides for V-Belt adjustment.
- ♥ See page G2-201 for drill and tap information required to mount to reducer.

▲ Includes adapter, necessary mounting bolts, and seal retainer. Both lip type and braided type seals included for customer's choice of application.

- ★ CEMA drive shaft and key is furnished unless otherwise specified. See pages G2-120 thru G2-122 for optional drive shafts available from DODGE.

SELECTION/DIMENSIONS



Screw Conveyor Shaft Mount Speed Reducers SCXT205 - SINGLE REDUCTION SCREW CONVEYOR DRIVES

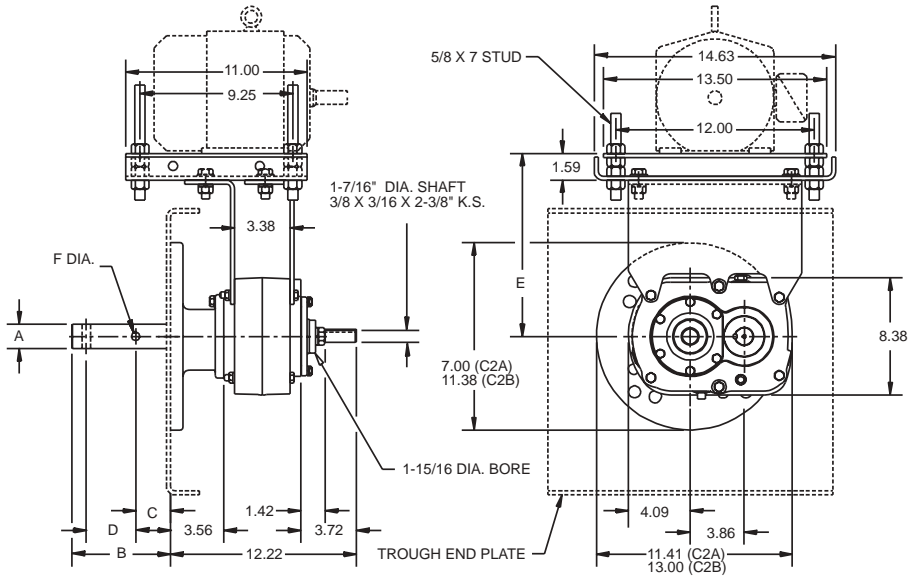

SCXT205 Screw Conveyor Drive †

Reducers				
Size	Part No.	AGMA Code	Ratio	Weight
SCXT205	352218	115S05	5.29	52

CEMA Drive Shafts ★									Adapter Assembly ▲		
Drive Shaft	Screw Dia.	Part No.	A	B	C	D	F Dia.	Weight	Size	Part No.	Weight
C2 x 1-1/2	6" - 9"	352090	1.50	6.00	2.13	3.00	.52	11.40	C2A	352052	15
									AC2B ♣	356112	25
C2 x 2	9" - 12'	352091	2.00	6.00	2.13	3.00	.64	13.80	C2B	352053	26
C2 x 2-7/16	12" - 1'4"	352092	2.44	6.69	2.75	3.00	.64	17.30	AC2B ♣	356112	25
C2 x 3	12" - 20"	352093	3.00	6.88	2.88	3.00	.77	19			

FEATURES/BENEFITS PAGE G2-3	NOMENCLATURE PAGE G2-11	SELECTION PAGE G2-81	RELATED PRODUCTS PAGE G2-152
--------------------------------	----------------------------	-------------------------	---------------------------------



Screw Conveyor Shaft Mount Speed Reducers SCXT205 - SINGLE REDUCTION SCREW CONVEYOR DRIVES

SCXT205 Accessories

Description	NEMA Motor Frame	Screw Dia.	Part No.	Weight
M214 Standard Motor Mount	56T thru 210T	6" - 14"	352069	43
M220L Long Motor Mount	56T thru 210T	16" - 20"	272626	51
SCXT2-S SCD Reducer Belt Guard	56T thru 210T	-	242491	34
SCXT2-S SCD Reducer Belt Guard for Long Motor Mount	56T thru 210T	-	242114	41
SCXT205 Auxiliary Seal Kit ♥	-	-	252146	3

SCXT205 Motor Mount Assembly Dimensions

Motor Mount	E ♦		V-Belt Drive Center Distances for Various NEMA Motor Frames					
			56, 140		180		210	
	Min.	Max.	Min.	Max.	Min.	Max.	Min.	Max.
M214	12.6	16.8	17.0	20.5	18.0	21.4	18.7	22.2
M220L	18.6	22.8	23.0	26.4	24.0	27.5	24.7	28.2

† Complete drive consists of reducer, CEMA drive shaft and key, and adapter assembly. Drive is shipped unassembled.

♣ AC adjustable packing adapter furnished if specified. C-style adapter is standard.

◆ Provides for V-Belt adjustment.

♥ See page G2-201 for drill and tap information required to mount to reducer.

▲ Includes adapter, necessary mounting bolts, and seal retainer. Both lip type and braided type seals included for customer's choice of application.

★ CEMA drive shaft and key is furnished unless otherwise specified. See pages G2-120 thru G2-122 for optional drive shafts available from DODGE.

FEATURES/BENEFITS PAGE G2-3	NOMENCLATURE PAGE G2-11	SELECTION PAGE G2-81	RELATED PRODUCTS PAGE G2-152
--------------------------------	----------------------------	-------------------------	---------------------------------



SELECTION/DIMENSIONS

Screw Conveyor Shaft Mount Speed Reducers SCXT3A - DOUBLE REDUCTION SCREW CONVEYOR DRIVES

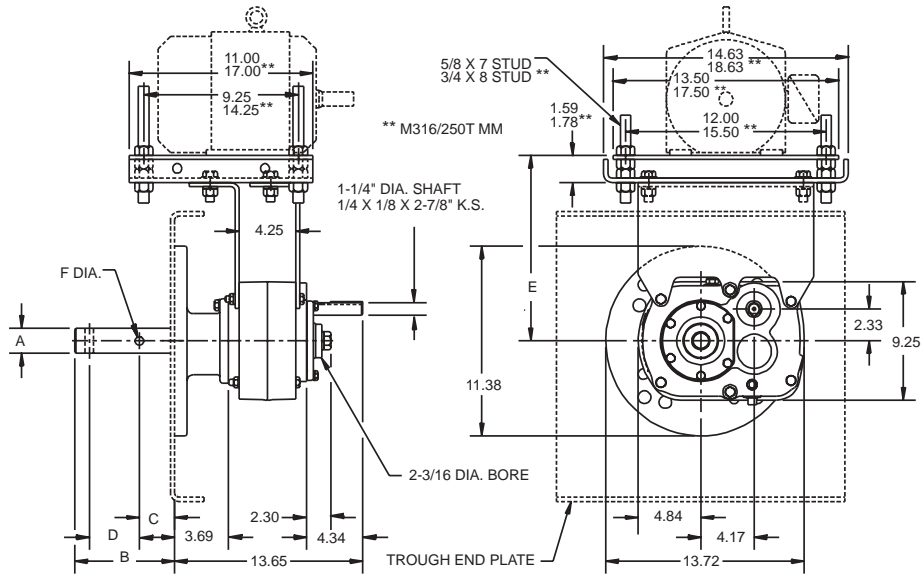

SCXT3 Screw Conveyor Drives †

Reducers				
Size	Part No.	AGMA Code	Ratio	Weight
SCXT309A	243524	203D09	8.91	98
SCXT315A	243525	203D15	14.88	98
SCXT325A	243526	203D25	24.71	98

CEMA Drive Shafts ★									Adapter Assembly ▲		
Drive Shaft	Screw Dia.	Part No.	A	B	C	D	F Dia.	Weight	Size	Part No.	Weight
C3A x 1-1/2	9"	243562	1.50	6.00	2.13	3.00	.52	15	C3 AC3B ▲	353047 356163	29 27
C3A x 2	9" - 12"	243563	2.00	6.00	2.13	3.00	.64	16			
C3A x 2-7/16	12" - 14"	243564	2.44	6.69	2.75	3.00	.64	19.50			
C3A x 3	12" - 20"	243565	3.00	6.88	2.88	3.00	.77	26			



Screw Conveyor Shaft Mount Speed Reducers SCXT3A- DOUBLE REDUCTION SCREW CONVEYOR DRIVES

SCXT205 Accessories

Description	NEMA Motor Frame	Screw Dia.	Part No.	Weight
M316 Standard Motor Mount	56T thru 210T	6" - 16"	353069	44
M316/250T Special Motor Mount ■ ♣	250T	6" - 16"	353070	44
M320L Long Motor Mount	56T thru 210T	18" - 20"	272627	56
SCXT3-D SCD Reducer Belt Guard	56T thru 210T	-	243416	40
SCXT3-D SCD Reducer Belt Guard for Long Motor Mount	56T thru 210T	-	243154	48
SCXT3A Cooling Fan Assembly	-	-	243581	3
SCXT3A Auxiliary Seal Kit ♥	-	-	243582	5

SCXT3A Motor Mount Assembly Dimensions

Motor Mount	E ◆		V-Belt Drive Center Distances for Various NEMA Motor Frames							
			"56,140"		180		210		250	
	Min.	Max.	Min.	Max.	Min.	Max.	Min.	Max.	Min.	Max.
M316	13.8	18.0	15.8	19.3	16.8	20.3	17.6	21.0	18.6	22.0
M320L	19.8	24.0	21.8	25.3	22.8	26.3	23.6	27.0	-	-

† Complete drive consists of reducer, CEMA drive shaft and key, and adapter assembly. Drive is shipped unassembled.

- ♣ AC adjustable packing adapter furnished if specified. C-style adapter is standard.
- ◆ Provides for V-Belt adjustment.
- ♣ Drawing dimensions are noted as **.
- ♥ See page G2-201 for drill and tap information required to mount to reducer.

▲ Includes adapter, necessary mounting bolts, and seal retainer. Both lip type and braided type seals included for customer's choice of application.

- ★ CEMA drive shaft and key is furnished unless otherwise specified. See pages thru G2-120 thru G2-122 for optional drive shafts available from DODGE.
- DODGE standard belt guards will not fit with this motor mount.

FEATURES/BENEFITS PAGE G2-3	NOMENCLATURE PAGE G2-11	SELECTION PAGE G2-81	RELATED PRODUCTS PAGE G2-152
--------------------------------	----------------------------	-------------------------	---------------------------------

SELECTION/DIMENSIONS



Screw Conveyor Shaft Mount Speed Reducers SCXT305A - SINGLE REDUCTION SCREW CONVEYOR DRIVES

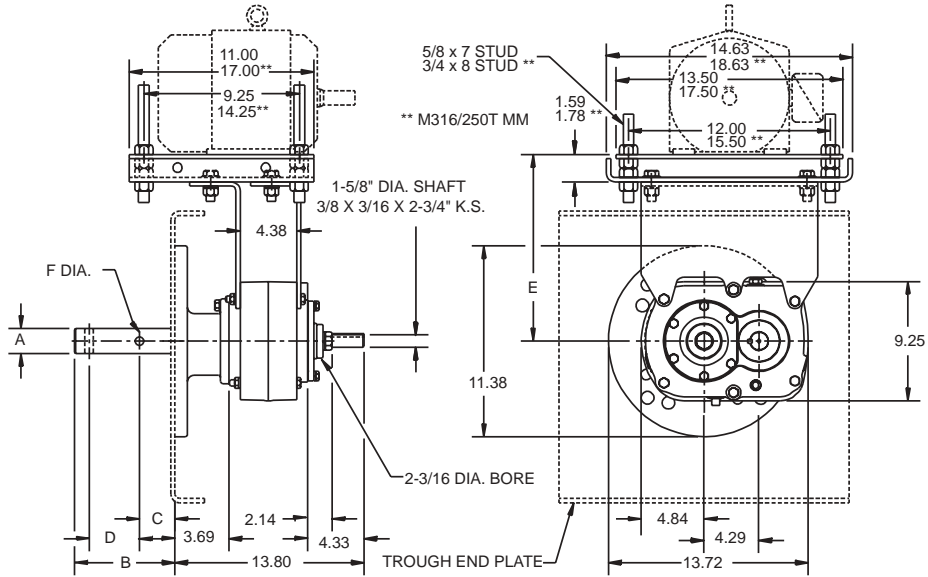

SCXT305A Screw Conveyor Drive †

Reducers				
Size	Part No.	AGMA Code	Ratio	Weight
SCXT305A	253159	203S05	5.60	86

CEMA Drive Shafts ★									Adapter Assembly ▲		
Drive Shaft	Screw Dia.	Part No.	A	B	C	D	F Dia.	Weight	Size	Part No.	Weight
C3A x 1-1/2	9"	243562	1.50	6.00	2.13	3	.52	15	C3 AC3B †	353047 356163	29 27
C3A x 2	9" - 12"	243563	2.00	6.00	2.13	3	.64	16			
C3A x 2-7/16	12" - 14"	243564	2.44	6.69	2.75	3	.64	19.5			
C3A x 3	12" - 20"	243565	3.00	6.88	2.88	3	.77	26			

FEATURES/BENEFITS PAGE G2-3	NOMENCLATURE PAGE G2-11	SELECTION PAGE G2-81	RELATED PRODUCTS PAGE G2-152
--------------------------------	----------------------------	-------------------------	---------------------------------



Screw Conveyor Shaft Mount Speed Reducers SCXT305A - SINGLE REDUCTION SCREW CONVEYOR DRIVES

SCXT305A Accessories

Description	NEMA Motor Frame	Screw Dia.	Part No.	Weight
M316 Standard Motor Mount	56T thru 210T	6'-16"	353069	44
M316/250T Special Motor Mount † ■	250T	6"-16"	353070	44
M320L Long Motor Mount	56T thru 210T	18"-20"	272627	56
SCXT3-S SCD Reducer Belt Guard	56T thru 210T	-	243418	40
SCXT3-S SCD Reducer Belt Guard for Long Motor Mount	56T thru 210T	-	243167	48
SCXT305A Cooling Fan Assembly	-	-	253188	3
SCXT305A Auxiliary Seal Kit ♥	-	-	253146	5

SCXT305A Motor Mount Assembly Dimensions

Motor Mount	E ◆		V-Belt Drive Center Distances for Various NEMA Motor Frames							
			56, 140		180		210		250	
	Min.	Max.	Min.	Max.	Min.	Max.	Min.	Max.	Min.	Max.
M316	13.8	18.0	18.2	21.6	19.2	22.6	19.5	23.4	20.9	24.4
M320L	19.8	24.0	24.2	27.6	25.2	28.6	25.9	29.4	-	-

† Complete drive consists of reducer, CEMA drive shaft and key, and adapter assembly. Drive is shipped unassembled.

- ♣ AC adjustable packing adapter furnished if specified. C-style adapter is standard.
- ◆ Provides for V-Belt adjustment.
- ♣ Drawing dimensions are noted as **.
- ♥ See page G2-201 for drill and tap information required to mount to reducer.

▲ Includes adapter, necessary mounting bolts, and seal retainer. Both lip type and braided type seals included for customer's choice of application.

- ★ CEMA drive shaft and key is furnished unless otherwise specified. See pages thru G2-120 thru G2-122 for optional drive shafts available from DODGE.
- DODGE standard belt guards will not fit with this motor mount. Consult DODGE for special belt guard.
- Consult DODGE for center distances

FEATURES/BENEFITS PAGE G2-3	NOMENCLATURE PAGE G2-11	SELECTION PAGE G2-81	RELATED PRODUCTS PAGE G2-152
--------------------------------	----------------------------	-------------------------	---------------------------------



SELECTION/DIMENSIONS

Screw Conveyor Shaft Mount Speed Reducers SCXT4A - DOUBLE REDUCTION SCREW CONVEYOR DRIVES

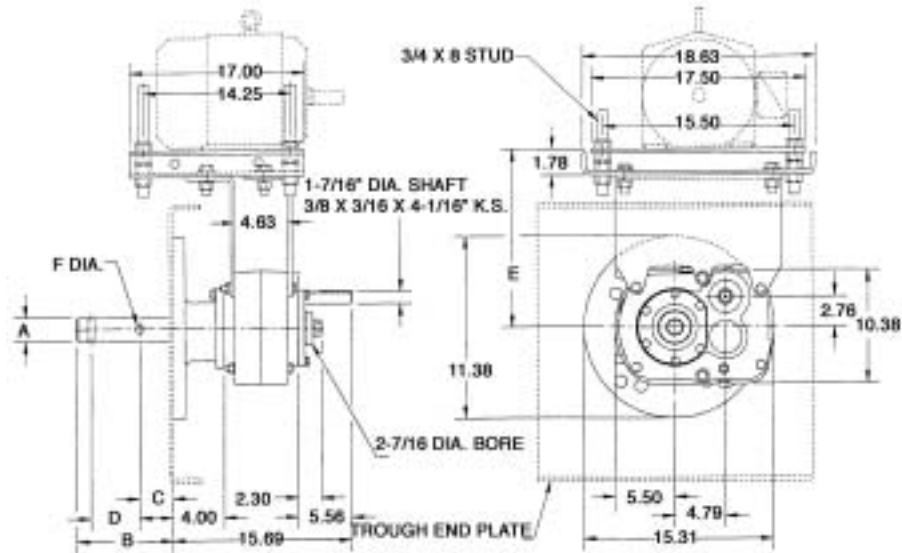

SCXT4A Screw Conveyor Drive †

Reducers				
Size	Part No.	AGMA Code	Ratio	Weight
SCXT409A	244549	207D09	9.67	139
SCXT415A	244550	207D15	15.13	139
SCXT425A	244551	207D25	24.38	139

CEMA Drive Shafts ★									Adapter Assembly ▲		
Drive Shaft	Screw Dia.	Part No.	A	B	C	D	F Dia.	Weight	Size	Part No.	Weight
C4A x 1-1/2	9"	244594	1.50	6.00	2.13	3	.52	19	C4 AC4 †	354121 356149	33 31
C4A x 2	9" - 12"	244595	2.00	6.00	2.13	3	.64	20.8			
C4A x 2-7/16	12" - 14"	244596	2.44	6.69	2.75	3	.64	24.3			
C4A x 3	12" - 20"	244597	3.00	6.88	2.88	3	.77	29.2			
C4A x 3-7/16	18" - 24"	244598	3.44	9.13	3.88	4	.89	39.3			



Screw Conveyor Shaft Mount Speed Reducers SCXT4A - DOUBLE REDUCTION SCREW CONVEYOR DRIVES

SCXT4A Accessories

Description	NEMA Motor Frame	Screw Dia.	Part No.	Weight
M418 Standard Motor Mount	140T thru 280T	9"-18"	354069	86
M418/320T Motor Mount ♣ ■	140T thru 320T	9"-18"	354028	90
M424L Long Motor Mount	140T thru 280T	20"-24"	272628	100
SCXT4-D SCD Reducer Belt Guard	140T thru 280T	-	244489	44
SCXT4-D SCD Reducer Belt Guard for Long Motor Mount	140T thru 280T	-	244152	53
SCXT4A Cooling Fan Assembly	-	-	272594	3
SCXT4A Auxiliary Seal Kit ♥	-	-	244677	5

SCXT4A Motor Mount Assembly Dimensions

Motor Mount	E ◆		V-Belt Drive Center Distances for Various NEMA Motor Frames											
			56, 140		180		210		250		280		320	
	Min.	Max.	Min.	Max.	Min.	Max.	Min.	Max.	Min.	Max.	Min.	Max.	Min.	Max.
M418	15.3	20.1	16.9	21.0	17.9	22.0	18.6	22.7	19.6	23.7	20.4	24.5	21.4	25.4
M424L	21.3	26.1	23.2	27.0	24.2	28.0	24.9	28.6	25.9	29.6	26.7	30.4		

† Complete drive consists of reducer, CEMA drive shaft and key, and adapter assembly. Drive is shipped unassembled.

♣ AC adjustable packing adapter furnished if specified. C-style adapter is standard.

◆ Provides for V-Belt adjustment.

♣ Made to order

♥ See page G2-201 for drill and tap information required to mount to reducer.

▲ Includes adapter, necessary mounting bolts, and seal retainer. Both lip type and braided type seals included for customer's choice of application.

★ CEMA drive shaft and key is furnished unless otherwise specified. See pages thru G2-120 thru G2-122 for optional drive shafts available from DODGE.

■ DODGE standard belt guards will not fit with this motor mount. Consult DODGE for special belt guard.

FEATURES/BENEFITS PAGE G2-3	NOMENCLATURE PAGE G2-11	SELECTION PAGE G2-81	RELATED PRODUCTS PAGE G2-152
--------------------------------	----------------------------	-------------------------	---------------------------------

SELECTION/DIMENSIONS



Screw Conveyor Shaft Mount Speed Reducers SCXT405A - SINGLE REDUCTION SCREW CONVEYOR DRIVES

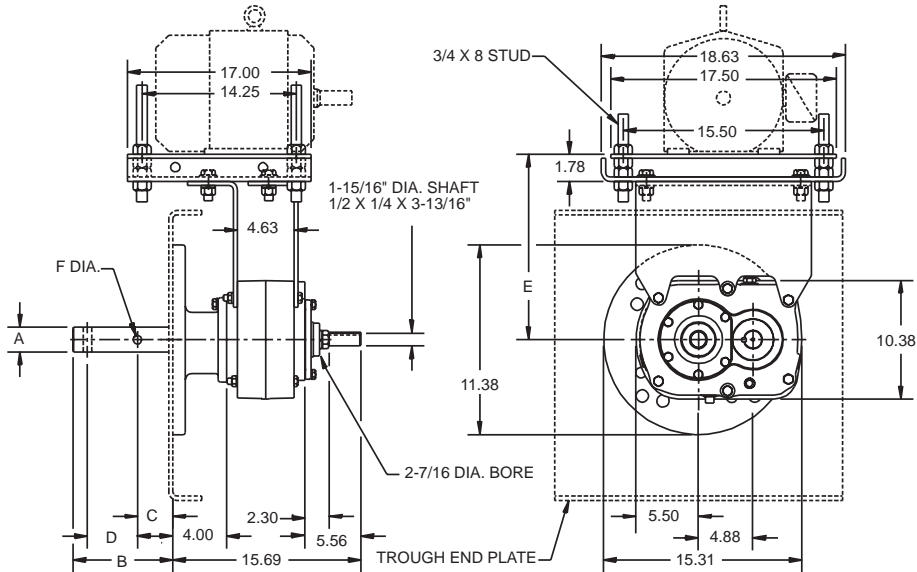

SCXT405A Screw conveyor Drive †

Reducers				
Size	Part No.	AGMA Code	Ratio	Weight
SCXT405A	254208	207S05	5.65	122

CEMA Drive Shafts ★									Adapter Assembly ▲		
Drive Shaft	Screw Dia.	Part No.	A	B	C	D	F Dia.	Weight	Size	Part No.	Weight
C4 x 1-1/2	9"	244594	1.50	6.00	2.13	3.00	.52	19	C4 AC4 †	354121 356149	33 31
C4 x 2	9" - 12"	244595	2.00	6.00	2.13	3.00	.64	20.80			
C4 x 2-7/16	12" - 14"	244596	2.44	6.69	2.75	3.00	.64	24.30			
C4 x 3	12" - 20"	244597	3.00	6.88	2.88	3.00	.77	29.20			
C4 x 3-7/16	18" - 24"	244598	3.44	9.13	3.88	4.00	.89	39.30			

FEATURES/BENEFITS
PAGE G2-3

NOMENCLATURE
PAGE G2-11

SELECTION
PAGE G2-81

RELATED PRODUCTS
PAGE G2-152



Screw Conveyor Shaft Mount Speed Reducers SCXT405A- SINGLE REDUCTION SCREW CONVEYOR DRIVES

SCXT405A Accessories

Description	NEMA Motor Frame	Screw Dia.	Part No.	Weight
M418 Standard Motor Mount	140T thru 280T	9"-18"	354069	86
M418/320T Motor Mount ■ ❖	140T thru 320T	9"-18"	354028	90
M424L Long Motor Mount	140T thru 280T	20"-24"	272628	100
SCXT4-S SCD Reducer Belt Guard	140T thru 280T	-	244491	50
SCXT4-S SCD Reducer Belt Guard for Long Motor Mount	140T thru 280T	-	244167	60
SCXT405A Cooling Fan Assembly	-	-	254268	3
SCXT405A Auxiliary Seal Kit ♥	-	-	254146	5

SCXT405A Motor Mount Assembly Dimensions

Motor Mount	E ◆		V-Belt Drive Center Distances for Various NEMA Motor Frames											
			56, 140		180		210		250		280		320	
	Min.	Max.	Min.	Max.	Min.	Max.	Min.	Max.	Min.	Max.	Min.	Max.	Min.	Max.
M418	15.3	20.1	19.6	23.7	20.6	24.7	21.4	25.5	22.4	26.5	23.0	27.2	21.4	25.4
M424L	21.3	26.1	25.9	29.7	26.9	30.7	27.7	31.4	28.7	32.3	29.4	33.2		

† Complete drive consists of reducer, CEMA drive shaft and key, and adapter assembly. Drive is shipped unassembled.

❖ AC adjustable packing adapter furnished if specified. C-style adapter is standard.

◆ Provides for V-Belt adjustment.

❖ Made to order

♥ See page G2-201 for drill and tap information required to mount to reducer.

▲ Includes adapter, necessary mounting bolts, and seal retainer. Both lip type and braided type seals included for customer's choice of application.

★ CEMA drive shaft and key is furnished unless otherwise specified. See pages thru G2-120 thru G2-122 for optional drive shafts available from DODGE.

■ DODGE standard belt guards will not fit with this motor mount. Consult DODGE for special belt guard.

FEATURES/BENEFITS PAGE G2-3	NOMENCLATURE PAGE G2-11	SELECTION PAGE G2-81	RELATED PRODUCTS PAGE G2-152
--------------------------------	----------------------------	-------------------------	---------------------------------

SELECTION/DIMENSIONS



Screw Conveyor Shaft Mount Speed Reducers SCXT5B - DOUBLE REDUCTION SCREW CONVEYOR DRIVES

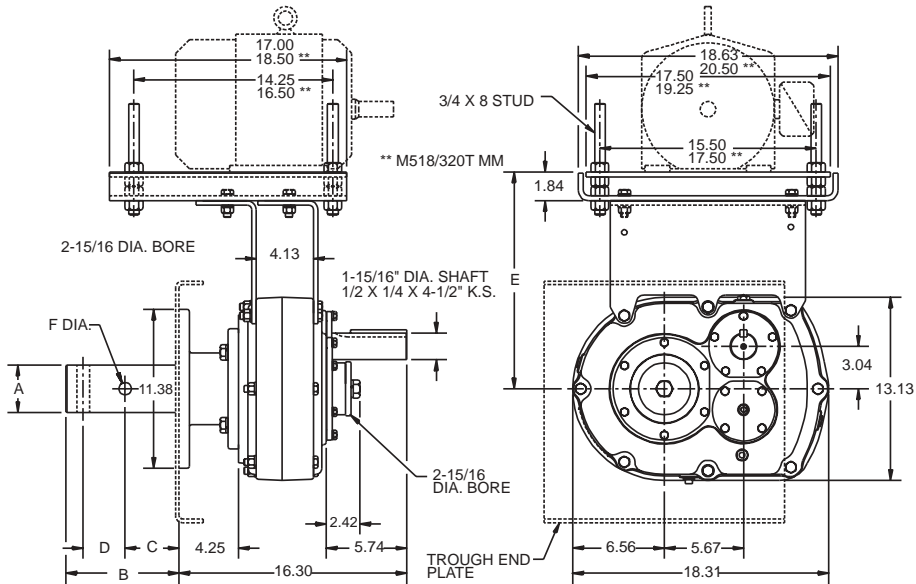

SCXT5B Screw Conveyor Drives †

Reducers				
Size	Part No.	AGMA Code	Ratio	Weight
SCXT509B	245574	215D09	8.95	207
SCXT515B	245575	215D15	15.40	207
SCXT525B	245576	215D25	25.56	207

CEMA Drive Shafts ★									Adapter Assembly ▲		
Drive Shaft	Screw Dia.	Part No.	A	B	C	D	F Dia.	Weight	Size	Part No.	Weight
C5B x 2	9"	355175	2.00	6.00	2.13	3.00	.64	29.4	C5	355072	43
C5B x 2-7/16	9" - 12"	355176	2.44	6.69	2.75	3.00	.64	33			
C5B x 3	12" - 14"	355177	3.00	6.88	2.88	3.00	.77	37.9	AC5 ♣	356158	43
C5B x 3-7/16	12" - 20"	355178	3.44	9.13	3.88	4.00	.89	48.3			

FEATURES/BENEFITS PAGE G2-3	NOMENCLATURE PAGE G2-11	SELECTION PAGE G2-81	RELATED PRODUCTS PAGE G2-152
--------------------------------	----------------------------	-------------------------	---------------------------------



Screw Conveyor Shaft Mount Speed Reducers SCXT5B - DOUBLE REDUCTION SCREW CONVEYOR DRIVES

SCXT5B Accessories

Description	NEMA Motor Frame	Screw Dia.	Part No.	Weight
M518 Standard Motor Mount	140T thru 280T	9"-18"	355169	82
M518/320T Special Motor Mount ♣ ■	320T	9"-18"	355168	82
M524L Long Motor Mount	140T thru 280T	20"-24"	272629	110
SCXT5-D SCD Reducer Belt Guard	140T thru 280T	-	245495	45
SCXT5-D SCD Reducer Belt Guard for Long Motor Mount	140T thru 280T	-	245103	54
SCXT5B Cooling Fan Assembly	-	-	272369	3
SCXT5B Auxiliary Seal Kit ♥	-	-	245637	6

SCXT5B Motor Mount Assembly Dimensions

Motor Mount	E ◆		V-Belt Drive Center Distances for Various NEMA Motor Frames											
			56, 140		180		210		250		280		320	
	Min.	Max.	Min.	Max.	Min.	Max.	Min.	Max.	Min.	Max.	Min.	Max.	Min.	Max.
M518	15.3	20.1	16.6	20.7	17.6	21.7	18.4	22.4	19.4	23.4	20.0	24.2	21.1	25.20
M524L	21.3	26.1	22.9	26.6	23.9	27.6	24.7	28.4	25.7	29.4	26.4	30.1	-	-

† Complete drive consists of reducer, CEMA drive shaft and key, and adapter assembly. Drive is shipped unassembled.

♣ AC adjustable packing adapter furnished if specified. C-style adapter is standard.

◆ Provides for V-Belt adjustment.

♣ Made to order. Drawing dimensions are noted as **.

♥ See page G2-201 for drill and tap information required to mount to reducer.

▲ Includes adapter, necessary mounting bolts, and seal retainer. Both lip type and braided type seals included for customer's choice of application.

★ CEMA drive shaft and key is furnished unless otherwise specified. See pages thru G2-120 thru G2-122 for optional drive shafts available from DODGE.

■ DODGE standard belt guards will not fit with this motor mount. Consult DODGE for special belt guard.

FEATURES/BENEFITS PAGE G2-3	NOMENCLATURE PAGE G2-11	SELECTION PAGE G2-81	RELATED PRODUCTS PAGE G2-152
--------------------------------	----------------------------	-------------------------	---------------------------------

SELECTION/DIMENSIONS



Screw Conveyor Shaft Mount Speed Reducers SCXT505A - SINGLE REDUCTION SCREW CONVEYOR DRIVES

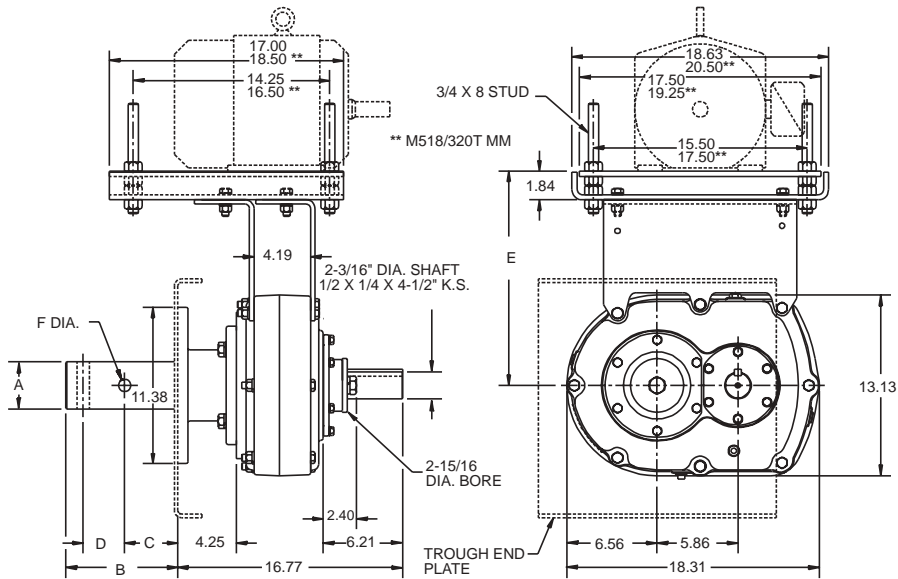

SCXT505A Screw Conveyor Drive †

Reducers				
Size	Part No.	AGMA Code	Ratio	Weight
SCXT505A	255208	215S05	5.67	182

CEMA Drive Shafts ★									Adapter Assembly ▲		
Drive Shaft	Screw Dia.	Part No.	A	B	C	D	F Dia.	Weight	Size	Part No.	Weight
C5B x 2	9" - 12"	355175	2.00	6.00	2.13	3.00	.64	29.40	C5 AC5 †	355072 356158	43 43
C5B x 2-7/16	12" - 14"	355176	2.44	6.69	2.75	3.00	.64	33			
C5B x 3	12" - 20"	355177	3.00	6.88	2.88	3.00	.77	37.90			
C5B x 3-7/16	18" - 24"	355178	3.44	9.13	3.88	4.00	.89	48.30			

FEATURES/BENEFITS
PAGE G2-3

NOMENCLATURE
PAGE G2-11

SELECTION
PAGE G2-81

RELATED PRODUCTS
PAGE G2-152



Screw Conveyor Shaft Mount Speed Reducers SCXT505A - SINGLE REDUCTION SCREW CONVEYOR DRIVES

SCXT505A Accessories

Description	NEMA Motor Frame	Screw Dia.	Part No.	Weight
M518 Standard Motor Mount	140T thru 280T	9"-18"	355169	82
M518/320T Special Motor Mount † ■	320T	9"-18"	355168	82
M524L Long Motor Mount	140T thru 280T	20"-24"	272629	110
SCXT5-S SCD Reducer Belt Guard	140T thru 280T	-	245497	70
SCXT5-S SCD Reducer Belt Guard for Long Motor Mount	140T thru 280T	-	245015	84
SCXT505A Cooling Fan Assembly	-	-	255231	3
SCXT505A Auxiliary Seal Kit ♥	-	-	255148	6

SCXT505A Motor Mount Assembly Dimensions

SCD Motor Mount	E ◆		V-Belt Drive Center Distances for Various NEMA Motor Frames											
			56, 140		180		210		250		280		320	
	Min.	Max.	Min.	Max.	Min.	Max.	Min.	Max.	Min.	Max.	Min.	Max.	Min.	Max.
M518	15.3	20.1	19.7	23.8	20.7	24.7	21.4	25.5	22.4	26.5	23.0	27.2	24.2	28.2
M524L	21.3	26.1	25.9	29.7	26.9	30.7	27.7	31.4	28.7	32.4	29.5	33.2	-	-

† Complete drive consists of reducer, CEMA drive shaft and key, and adapter assembly. Drive is shipped unassembled.

◆ AC adjustable packing adapter furnished if specified. C-style adapter is standard.

◆ Provides for V-Belt adjustment.

◆ Made to order. Drawing dimensions are noted as **.

♥ See page G2-201 for drill and tap information required to mount to reducer.

▲ Includes adapter, necessary mounting bolts, and seal retainer. Both lip type and braided type seals included for customer's choice of application.

★ CEMA drive shaft and key is furnished unless otherwise specified. See pages thru G2-120 thru G2-122 for optional drive shafts available from DODGE.

■ DODGE standard belt guards will not fit with this motor mount. Consult DODGE for special belt guard.

FEATURES/BENEFITS PAGE G2-3	NOMENCLATURE PAGE G2-11	SELECTION PAGE G2-81	RELATED PRODUCTS PAGE G2-152
--------------------------------	----------------------------	-------------------------	---------------------------------

SELECTION/DIMENSIONS



Screw Conveyor Shaft Mount Speed Reducers SCXT6 - DOUBLE REDUCTION SCREW CONVEYOR DRIVES

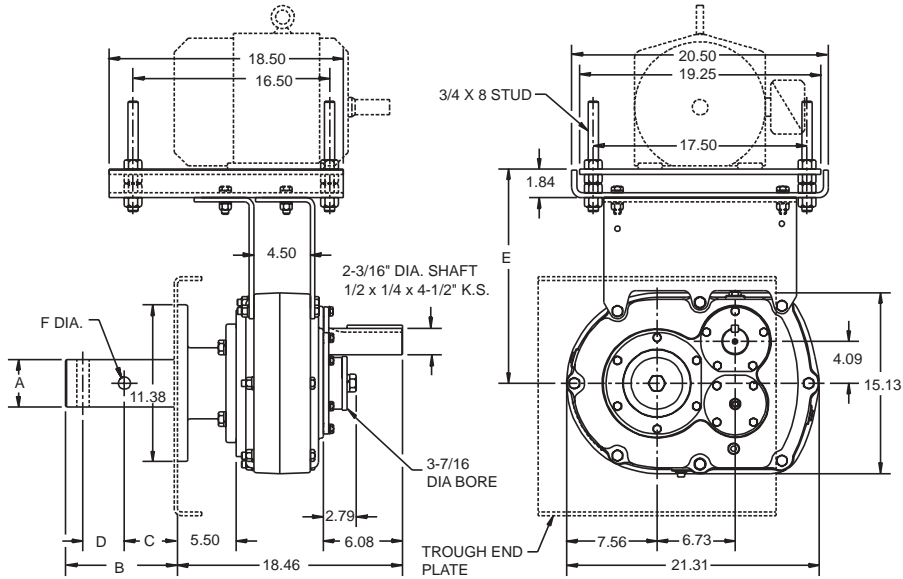

SCXT6 Screw Conveyor Drive †

Reducers				
Size	Part No.	AGMA Code	Ratio	Weight
SCXT609	246480	307D09	9.20	285
SCXT615	356057	307D15	15.33	285
SCXT625	356058	307D25	25.13	285

CEMA Drive Shafts ★									Adapter Assembly ▲		
Drive Shaft	Screw Dia.	Part No.	A	B	C	D	F Dia.	Weight	Size	Part No.	Weight
C6 x 2-7/16	12" - 14"	356042	2.44	6.69	2.75	3.00	.64	47.70	C6 AC6 †	356055 356154	56 56
C6 x 3	12" - 20"	356043	3.00	6.88	2.88	3.00	.77	52.70			
C6 x 3-7/16	18" - 24"	356044	3.44	9.13	3.88	4.00	.89	63			

FEATURES/BENEFITS
PAGE G2-3

NOMENCLATURE
PAGE G2-11

SELECTION
PAGE G2-81

RELATED PRODUCTS
PAGE G2-152



Screw Conveyor Shaft Mount Speed Reducers SCXT6 - DOUBLE REDUCTION SCREW CONVEYOR DRIVES

SCXT6 Accessories

Description	NEMA Motor Frame	Screw Dia.	Part No.	Weight
M620 Standard Motor Mount	140T thru 320T	12"-20"	356069	105
M624L Long Motor Mount	140T thru 320T	24"	272630	122
SCXT6-D SCD Reducer Belt Guard	140T thru 320T	-	246476	60
SCXT6-D SCD Reducer Belt Guard for Long Motor Mount	140T thru 320T	-	246148	72
SCXT6 Cooling Fan Assembly	-	-	272325	3
SCXT6 Auxiliary Seal Kit	-	-	272726	7

SCXT6 Motor Mount Assembly Dimensions

Motor Mount	E ◆		V-Belt Drive Center Distances for Various NEMA Motor Frames											
			56, 140		180		210		250		280		320	
	Min.	Max.	Min.	Max.	Min.	Max.	Min.	Max.	Min.	Max.	Min.	Max.	Min.	Max.
M620	16.7	21.4	17.0	21.0	18.0	22.0	18.8	22.8	19.7	23.8	20.5	24.5	21.5	25.5
M624L	22.7	27.4	23.2	27.0	24.2	27.9	24.9	28.7	25.9	29.7	26.7	30.5	27.6	31.4

† Complete drive consists of reducer, CEMA drive shaft and key, and adapter assembly. Drive is shipped unassembled.

♣ AC adjustable packing adapter furnished if specified. C-style adapter is standard.

◆ Provides for V-Belt adjustment.

▲ Includes adapter, necessary mounting bolts, and seal retainer. Both lip type and braided type seals included for customer's choice of application.

★ CEMA drive shaft and key is furnished unless otherwise specified. See pages G2-120 thru G2-122 for optional drive shafts available from DODGE.

FEATURES/BENEFITS PAGE G2-3	NOMENCLATURE PAGE G2-11	SELECTION PAGE G2-81	RELATED PRODUCTS PAGE G2-152
--------------------------------	----------------------------	-------------------------	---------------------------------



SELECTION/DIMENSIONS

Screw Conveyor Shaft Mount Speed Reducers SCXT605 - SINGLE REDUCTION SCREW CONVEYOR DRIVES

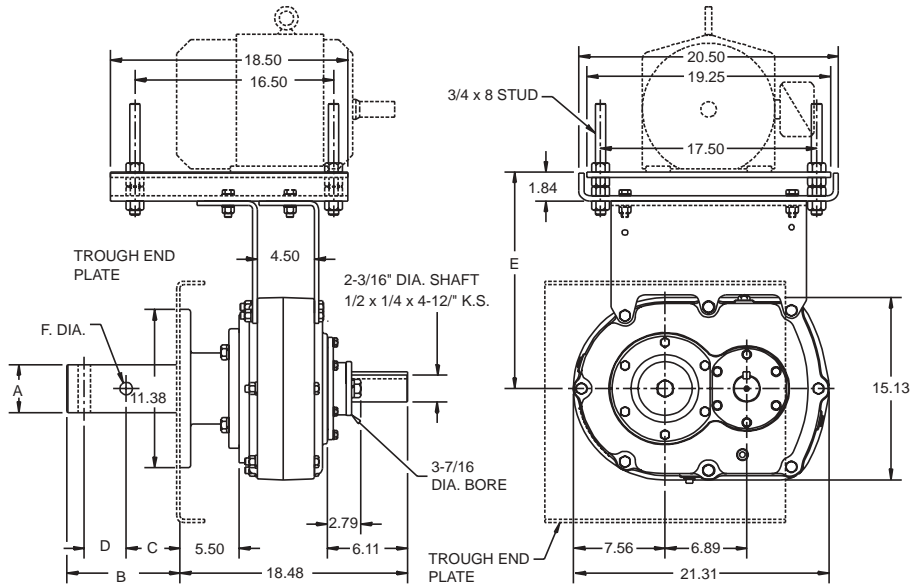

SCXT605 Screw Conveyor Drive †

Reducers				
Size	Part No.	AGMA Code	Ratio	Weight
SCXT605	356285	307S05	5.67	251

CEMA Drive Shafts ★									Adapter Assembly ▲		
Drive Shaft	Screw Dia.	Part No.	A	B	C	D	F Dia.	Weight	Size	Part No.	Weight
C6 x 2-7/16	12" - 14"	356042	2.44	6.69	2.75	3.00	.64	47.70	C6 AC6 †	356055	56
C6 x 3	12" - 20"	356043	3.00	6.88	2.88	3.00	.77	52.70		356154	56
C6 x 3-7/16	18" - 24"	356044	3.44	9.13	3.88	4.00	.89	63			



Screw Conveyor Shaft Mount Speed Reducers SCXT605 - SINGLE REDUCTION SCREW CONVEYOR DRIVES

SCXT605 Accessories

Description	NEMA Motor Frame	Screw Dia.	Part No.	Weight
M620 Standard Motor Mount	140T thru 320T	12"-20"	356069	105
M624L Long Motor Mount	140T thru 320T	24"	272630	122
SCXT6-S SCD Reducer Belt Guard	140T thru 320T	-	246478	77
SCXT6-S SCD Reducer Belt Guard for Long Motor Mount	140T thru 320T	-	246142	92
SCXT605 Cooling Fan Assembly	-	-	272681	3
SCXT6 Auxiliary Seal Kit	-	-	272726	7

SCXT605 Motor Mount Assembly Dimensions

Motor Mount	E ◆		V-Belt Drive Center Distances for Various NEMA Motor Frames											
			56, 140		180		210		250		280		320	
	Min.	Max.	Min.	Max.	Min.	Max.	Min.	Max.	Min.	Max.	Min.	Max.	Min.	Max.
M620	16.7	21.4	21.1	25.1	22.1	26.1	22.8	26.8	23.8	27.9	24.6	28.6	25.6	29.6
M624L	22.7	27.4	27.2	31.1	28.2	32.1	29.0	32.8	30.0	33.8	30.7	34.6	31.7	35.5

† Complete drive consists of reducer, CEMA drive shaft and key, and adapter assembly. Drive is shipped unassembled.

- ♣ AC adjustable packing adapter furnished if specified. C-style adapter is standard.
- ◆ Provides for V-Belt adjustment.

- ▲ Includes adapter, necessary mounting bolts, and seal retainer. Both lip type and braided type seals included for customer's choice of application.
- ★ CEMA drive shaft and key is furnished unless otherwise specified. See pages G2-120 thru G2-122 for optional drive shafts available from DODGE.

FEATURES/BENEFITS PAGE G2-3	NOMENCLATURE PAGE G2-11	SELECTION PAGE G2-81	RELATED PRODUCTS PAGE G2-152
--------------------------------	----------------------------	-------------------------	---------------------------------

SELECTION/DIMENSIONS



Screw Conveyor Shaft Mount Speed Reducers SCXT7 - DOUBLE REDUCTION SCREW CONVEYOR DRIVES

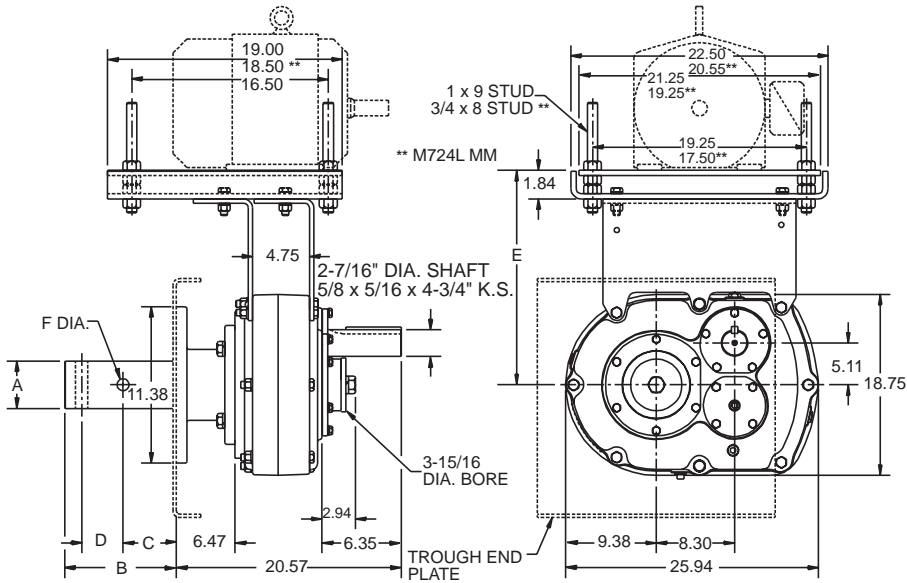

SCXT7 Screw Conveyor Drive †

Reducers				
Size	Part No.	AGMA Code	Ratio	Weight
SCXT709	247480	315D09	9.61	462
SCXT715	356256	315D15	15.23	462
SCXT725	356257	315D25	24.59	462

CEMA Drive Shafts ★									Adapter Assembly ▲		
Drive Shaft	Screw Dia.	Part No.	A	B	C	D	F Dia.	Weight	Size	Part No.	Weight
C7 x 2-7/16	12" - 14"	356182	2.44	6.69	2.75	3.00	.64	58	C7 AC7 †	356187 356192	72 72
C7 x 3	12" - 20"	356183	3.00	6.88	2.88	3.00	.77	70			
C7 x 3-7/16	18" - 24"	356184	3.44	9.13	3.88	4.00	.89	80.30			

FEATURES/BENEFITS
PAGE G2-3

NOMENCLATURE
PAGE G2-11

SELECTION
PAGE G2-81

RELATED PRODUCTS
PAGE G2-152

SELECTION/DIMENSIONS



Screw Conveyor Shaft Mount Speed Reducers SCXT7 - DOUBLE REDUCTION SCREW CONVEYOR DRIVES

SCXT7 Accessories

Description	NEMA Motor Frame	Screw Dia.	Part No.	Weight
M720 Standard Motor Mount	140T thru 360T	12"-20"	356269	106
M724L Long Motor Mount v	140T thru 320T	24"	272631	130
SCXT7-D SCD Reducer Belt Guard	140T thru 360T	-	247474	75
SCXT7-D SCD Reducer Belt Guard for Long Motor Mount	140T thru 320T	-	247153	90
SCXT7 Cooling Fan Assembly	-	-	272326	6
SCXT7 Auxiliary Seal Kit	-	-	272727	8

SCXT7 Motor Mount Assembly Dimensions

Motor Mount	E ◆		V-Belt Drive Center Distances for Various NEMA Motor Frames													
			"56,140"		180		210		250		280		320		360	
	Min.	Max.	Min.	Max.	Min.	Max.	Min.	Max.	Min.	Max.	Min.	Max.	Min.	Max.	Min.	Max.
M720	17.5	21.7	17.1	20.5	18.1	21.5	18.8	22.2	19.8	23.2	20.5	24.0	21.5	25.0	22.5	26.0
M724L	23.5	27.7	22.4	26.1	23.3	27.1	24.1	27.8	25.0	28.8	25.8	29.5	26.8	30.5	---	---

- † Complete drive consists of reducer, CEMA drive shaft and key, and adapter assembly. Drive is shipped unassembled.
- ♣ AC adjustable packing adapter furnished if specified. C-style adapter is standard.
- ◆ Provides for V-Belt adjustment.

- ▲ Includes adapter, necessary mounting bolts, and seal retainer. Both lip type and braided type seals included for customer's choice of application.
- ★ CEMA drive shaft and key is furnished unless otherwise specified. See pages G2-120 thru G2-122 for optional drive shafts available from DODGE.

FEATURES/BENEFITS PAGE G2-3	NOMENCLATURE PAGE G2-11	SELECTION PAGE G2-81	RELATED PRODUCTS PAGE G2-152
--------------------------------	----------------------------	-------------------------	---------------------------------

SELECTION/DIMENSIONS



Screw Conveyor Shaft Mount Speed Reducers SCXT705 - SINGLE REDUCTION SCREW CONVEYOR DRIVES

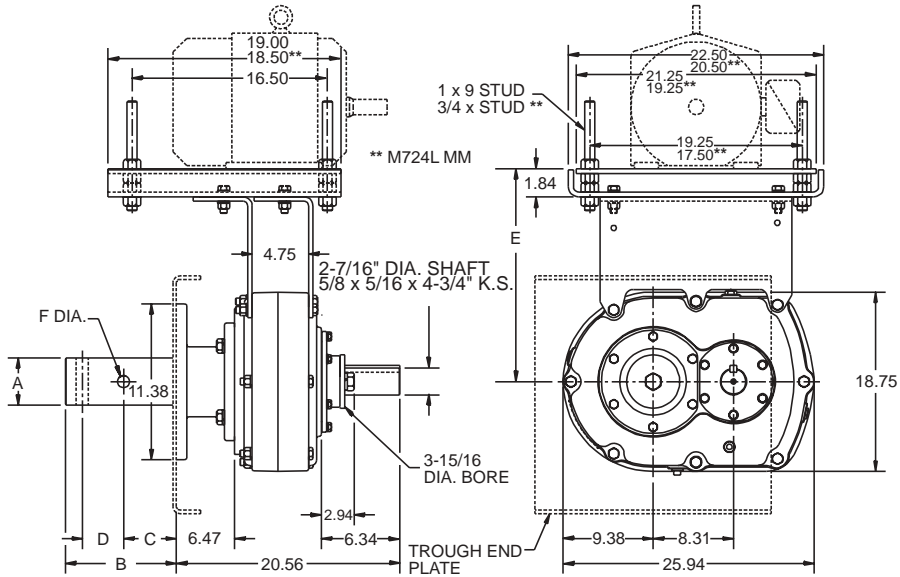

SCXT705 Screw Conveyor Drive †

Reducers				
Size	Part No.	AGMA Code	Ratio	Weight
SCXT705	356295	315S05	5.36	410

CEMA Drive Shafts ★									Adapter Assembly ▲		
Drive Shaft	Screw Dia.	Part No.	A	B	C	D	F Dia.	Weight	Size	Part No.	Weight
C7 x 2-7/16	12" - 14"	356182	2.44	6.69	2.75	3.00	.64	58	C7	356187	72
C7 x 3	12" - 20"	356183	3.00	6.88	2.88	3.00	.77	70	AC7 †	356192	72
C7 x 3-7/16	18" - 24"	356184	3.44	9.13	3.88	4.00	.89	80.30			

FEATURES/BENEFITS PAGE G2-3	NOMENCLATURE PAGE G2-11	SELECTION PAGE G2-81	RELATED PRODUCTS PAGE G2-152
--------------------------------	----------------------------	-------------------------	---------------------------------



Screw Conveyor Shaft Mount Speed Reducers SCXT705 - SINGLE REDUCTION SCREW CONVEYOR DRIVES

SCXT705 Accessories

Description	NEMA Motor Frame	Screw Dia.	Part No.	Weight
M720 Standard Motor Mount	140T thru 360T	12"-20"	356269	106
M724L Long Motor Mount †	140T thru 320T	24"	272631	130
SCXT7-S SCD Reducer Belt Guard	140T thru 360T	-	247476	84
SCXT7-S SCD Reducer Belt Guard for Long Motor Mount	140T thru 320T	-	247149	100
SCXT705 Cooling Fan Assembly	-	-	272685	6
SCXT705 Auxiliary Seal Kit	-	-	272727	8

SCXT705 Motor Mount Assembly Dimensions

Motor Mount	E ◆		V-Belt Drive Center Distances for Various NEMA Motor Frames													
			56, 140		180		210		250		280		320		360	
	Min.	Max.	Min.	Max.	Min.	Max.	Min.	Max.	Min.	Max.	Min.	Max.	Min.	Max.	Min.	Max.
M720	17.5	21.7	22.1	25.6	23.1	26.5	23.8	27.3	24.8	28.3	25.6	29.0	26.6	30.0	27.5	31.0
M724L	23.5	27.7	27.3	31.1	28.3	32.1	29.1	32.9	30.1	33.9	30.8	34.7	31.8	35.6	-	-

† Complete drive consists of reducer, CEMA drive shaft and key, and adapter assembly. Drive is shipped unassembled.

◆ AC adjustable packing adapter furnished if specified. C-style adapter is standard.

◆ Provides for V-Belt adjustment.

♥ See page G2-201 for drill and tap information required to mount to reducer.

▲ Includes adapter, necessary mounting bolts, and seal retainer. Both lip type and braided type seals included for customer's choice of application.

★ CEMA drive shaft and key is furnished unless otherwise specified. See pages G2-120 thru G2-122 for optional drive shafts available from DODGE.

♣ Made to order. Drawing dimensions are noted as **.

FEATURES/BENEFITS PAGE G2-3	NOMENCLATURE PAGE G2-11	SELECTION PAGE G2-81	RELATED PRODUCTS PAGE G2-152
--------------------------------	----------------------------	-------------------------	---------------------------------

SELECTION/DIMENSIONS



Screw Conveyor Shaft Mount Speed Reducers SCXT8 - DOUBLE REDUCTION SCREW CONVEYOR DRIVES

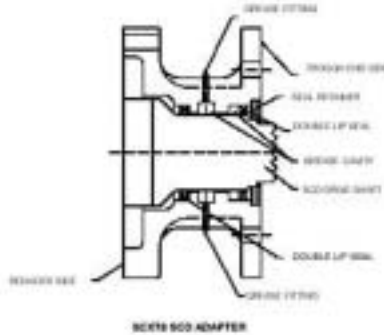
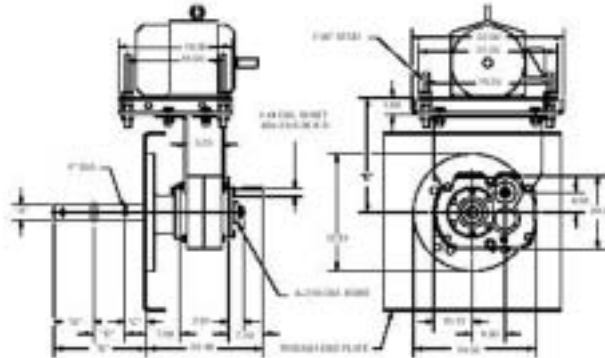

FEATURES/BENEFITS PAGE G2-3	NOMENCLATURE PAGE G2-11	SELECTION PAGE G2-81	RELATED PRODUCTS PAGE G2-152
--------------------------------	----------------------------	-------------------------	---------------------------------

SELECTION/DIMENSIONS



Screw Conveyor Shaft Mount Speed Reducers SCXT8 - DOUBLE REDUCTION SCREW CONVEYOR DRIVES

SCXT8 Screw Conveyor Drive †

Reducers				
Size	Part No.	AGMA Code	Ratio	Weight
SCXT815	248464 ♣	407D15	15.08	633
SCXT825	248465 ♣	407D25	24.62	633

CEMA Drive Shafts ★									Adapter Assembly ▲		
Drive Shaft	Screw Dia.	Part No.	A	B	C	D	F Dia.	Weight	Size	Part No.	Weight
C8 X 3	12" - 20"	248473 ♣	3.00	9.88	2.88	3.00	.77	88	C8 ♣	248470 ♣	90
C8 X 3-7/16	18" - 24"	248474 ♣	3.44	13.13	3.88	4.00	.89	100			

SCXT8 Accessories

Description	NEMA Motor Frame	Screw Dia.	Part No.	Weight
M824L Long Motor Mount ♣	210T thru 360T	12" - 24"	248469	163
SCXT8-D SCD Reducer Belt Guard ♣	210T thru 360T	---	248477	113
SCXT8 Cooling Fan Assembly	---	---	272327	9
SCXT8 Auxiliary Seal Kit ♣	---	---	248484	10

SCXT8 Motor Mount Assembly Dimensions

Motor Mount	E ◆		V-Belt Drive Center Distances for Various NEMA Motor Frames													
			56, 140		180		210		250		280		320		360	
	Min.	Max.	Min.	Max.	Min.	Max.	Min.	Max.	Min.	Max.	Min.	Max.	Min.	Max.	Min.	Max.
M824	22.70	28.60					23.3	28.4	24.3	29.4	25.1	30.1	26.0	31.1	27.0	32.1

† Complete drive consists of reducer, CEMA drive shaft and key, and adapter assembly. Drive is shipped unassembled.

♣ AC adjustable packing adapter furnished if specified. C-style adapter is standard.

◆ Provides for V-Belt adjustment.

♥ See page G2-201 for drill and tap information required to mount to reducer.

▲ Includes adapter, necessary mounting bolts, and seal retainer. Both lip type and braided type seals included for customer's choice of application.

★ CEMA 3-hole drive shaft and key is furnished as standard. For other C8 drive shafts, consult DODGE.

♣ Made to order. Drawing dimensions are noted as **.

FEATURES/BENEFITS PAGE G2-3	NOMENCLATURE PAGE G2-11	SELECTION PAGE G2-81	RELATED PRODUCTS PAGE G2-152
--------------------------------	----------------------------	-------------------------	---------------------------------

MODIFICATIONS/ ACCESSORIES

DODGE®

Screw Conveyor Shaft Mount Speed Reducers SCXT SCREW CONVEYOR DRIVE OPTIONAL DRIVE SHAFTS

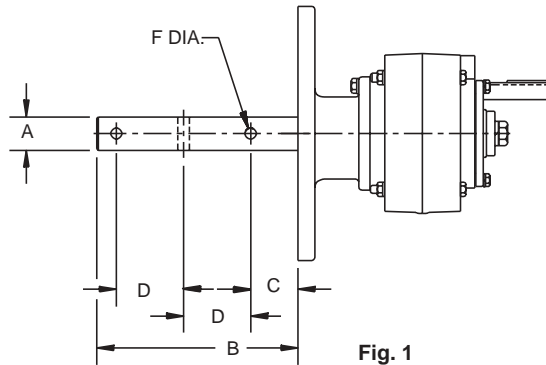

Fig. 1

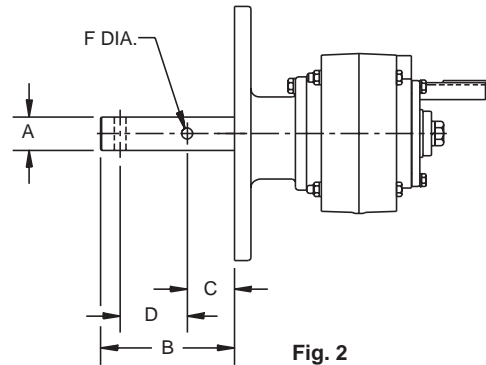

Fig. 2

SCXT1 Optional Drive Shafts

Description	Drive Shaft	Screw Dia.	Part No.	Figure	A	B	C	D	F	Weight
SCXT1 Stainless Steel * Drive Shafts	C1 x 1-1/2	6" - 9"	351147	2	1.50	6.00	2.13	3.00	0.52	7.20
	C1 x 2	9" - 12"	351148	2	2.00	6.00	2.13	3.00	0.64	9.10
	C1 x 2-7/16	12" - 14"	351149	2	2.44	6.69	2.75	3.00	0.64	12.50
	C1 x 3	12" - 20"	351150	2	3.00	6.88	2.88	3.00	0.77	17.40
SCXT1 3-Hole Drive Shafts	C1 x 1-1/2	6" - 9"	351300	1	1.50	9.00	2.13	3.00	0.52	8.70
	C1 x 2	9" - 12"	351301	1	2.00	9.00	2.13	3.00	0.64	11.80
	C1 x 2-7/16	12" - 14"	351302	1	2.44	9.69	2.75	3.00	0.64	16.40
	C1 x 3	12" - 20"	351303	1	3.00	9.88	2.88	3.00	0.77	23.40
SCXT1 Stainless Steel * 3-Hole Drive Shafts	C1 x 1-1/2	6" - 9"	351025	1	1.50	9.00	2.13	3.00	0.52	8.70
	C1 x 2	9" - 12"	351026	1	2.00	9.00	2.13	3.00	0.64	11.80
	C1 x 2-7/16	12" - 14"	351027	1	2.44	9.69	2.75	3.00	0.64	16.40
	C1 x 3	12" - 20"	351028	1	3.00	9.88	2.88	3.00	0.77	23.40

SCXT2 Optional Drive Shafts

Description	Drive Shaft	Screw Dia.	Part No.	Figure	A	B	C	D	F	Weight
SCXT2 Stainless Steel * Drive Shafts	C2 x 1-1/2	6" - 9"	352160	2	1.50	6.00	2.13	3.00	0.52	11.40
	C2 x 2	9" - 12"	352161	2	2.00	6.00	2.13	3.00	0.64	13.80
	C2 x 2-7/16	12" - 14"	352162	2	2.44	6.69	2.75	3.00	0.64	17.30
	C2 x 3	12" - 20"	352163	2	3.00	6.88	2.88	3.00	0.77	19
SCXT2 3-Hole Drive Shafts	C2 x 1-1/2	6" - 9"	351305	1	1.50	9.00	2.13	3.00	0.52	12.90
	C2 x 2	9" - 12"	351306	1	2.00	9.00	2.13	3.00	0.64	16.50
	C2 x 2-7/16	12" - 14"	351307	1	2.44	9.69	2.75	3.00	0.64	21.20
	C2 x 3	12" - 20"	351308	1	3.00	9.88	2.88	3.00	0.77	25
SCXT2 Stainless Steel * 3-Hole Drive Shafts	C2 x 1-1/2	6" - 9"	352186	1	1.50	9.00	2.13	3.00	0.52	12.90
	C2 x 2	9" - 12"	352187	1	2.00	9.00	2.13	3.00	0.64	16.50
	C2 x 2-7/16	12" - 14"	352188	1	2.44	9.69	2.75	3.00	0.64	21.20
	C2 x 3	12" - 20"	352189	1	3.00	9.88	2.88	3.00	0.77	25

* Supplied as #316 stainless steel.

FEATURES/BENEFITS
PAGE G2-3

NOMENCLATURE
PAGE G2-11

SELECTION/DIMENSIONS
PAGE G2-90

RELATED PRODUCTS
PAGE G2-152



Screw Conveyor Shaft Mount Speed Reducers

SCXT3A Optional Drive Shafts

Description	Drive Shaft	Screw Dia.	Part No.	Figure	A	B	C	D	F	Weight
SCXT3A Stainless Steel * Drive Shafts	C3A x 1-1/2	9"	243446	2	1.50	6.00	2.13	3.00	0.52	15
	C3A x 2	9" - 12"	243447	2	2.00	6.00	2.13	3.00	0.64	16
	C3A x 2-7/16	12" - 14"	243448	2	2.44	6.69	2.75	3.00	0.64	19.50
	C3A x 3	12" - 20"	243449	2	3.00	6.88	2.88	3.00	0.77	26
SCXT3A 3-Hole Drive Shafts	C3A x 1-1/2	9"	243016	1	1.50	9.00	2.13	3.00	0.52	16.50
	C3A x 2	9" - 12"	243017	1	2.00	9.00	2.13	3.00	0.64	18.70
	C3A x 2-7/16	12" - 14"	243018	1	2.44	9.69	2.75	3.00	0.64	23.40
	C3A x 3	12" - 20"	243019	1	3.00	9.88	2.88	3.00	0.77	32
SCXT3A Stainless Steel * 3-Hole Drive Shafts	C3A x 1-1/2	9"	353180	1	1.50	9.00	2.13	3.00	0.52	16.50
	C3A x 2	9" - 12"	353181	1	2.00	9.00	2.13	3.00	0.64	18.70
	C3A x 2-7/16	12" - 14"	353182	1	2.44	9.69	2.75	3.00	0.64	23.40
	C3A x 3	12" - 20"	353183	1	3.00	9.88	2.88	3.00	0.77	32

SCXT4A Optional Drive Shafts

Description	Drive Shaft	Screw Dia.	Part No.	Figure	A	B	C	D	F	Weight
SCXT4A Stainless Steel * Drive Shafts	C4A x 1-1/2	9"	244680	2	1.50	6.00	2.13	3.00	0.52	19
	C4A x 2	9" - 12"	244681	2	2.00	6.00	2.13	3.00	0.64	20.80
	C4A x 2-7/16	12" - 14"	244682	2	2.44	6.69	2.75	3.00	0.64	24.30
	C4A x 3	12" - 20"	244683	2	3.00	6.88	2.88	3.00	0.77	29.20
	C4A x 3-7/16	18" - 24"	244684	2	3.44	9.13	3.88	4.00	0.89	39.30
SCXT4A 3-Hole Drive Shafts	C4A x 1-1/2	9"	244494	1	1.50	9.00	2.13	3.00	0.52	20.50
	C4A x 2	9" - 12"	244496	1	2.00	9.00	2.13	3.00	0.64	23.50
	C4A x 2-7/16	12" - 14"	244497	1	2.44	9.69	2.75	3.00	0.64	28.20
	C4A x 3	12" - 20"	244498	1	3.00	9.88	2.88	3.00	0.77	35.20
	C4A x 3-7/16	18" - 24"	244499	1	3.44	14.13	3.88	4.00	0.89	49.80
SCXT4A Stainless Steel * 3-Hole Drive Shafts	C4A x 1-1/2	9"	354351	1	1.50	9.00	2.13	3.00	0.52	20.50
	C4A x 2	9" - 12"	354352	1	2.00	9.00	2.13	3.00	0.64	23.50
	C4A x 2-7/16	12" - 14"	354353	1	2.44	9.69	2.75	3.00	0.64	28.20
	C4A x 3	12" - 20"	354354	1	3.00	9.88	2.88	3.00	0.77	35.20
	C4A x 3-7/16	18" - 24"	354355	1	3.44	14.13	3.88	4.00	0.89	49.80

SCXT5B Optional Drive Shafts

Description	Drive Shaft	Screw Dia.	Part No.	Figure	A	B	C	D	F	Weight
SCXT5B Stainless Steel * Drive Shafts	C5B x 2	9" - 12"	245651	2	2.00	6.00	2.13	3.00	0.64	29.40
	C5B x 2-7/16	12" - 14"	245652	2	2.44	6.69	2.75	3.00	0.64	33
	C5B x 3	12" - 20"	245653	2	3.00	6.88	2.88	3.00	0.77	37.90
	C5B x 3-7/16	18" - 24"	245654	2	3.44	9.13	3.88	4.00	0.89	48.30
SCXT5B 3-Hole Drive Shafts	C5B x 2	9" - 12"	245474	1	2.00	9.00	2.13	3.00	0.64	32.10
	C5B x 2-7/16	12" - 14"	245476	1	2.44	9.69	2.75	3.00	0.64	36.90
	C5B x 3	12" - 20"	245477	1	3.00	9.88	2.88	3.00	0.77	43.90
	C5B x 3-7/16	18" - 24"	245478	1	3.44	14.13	3.88	4.00	0.89	58.80
SCXT5B Stainless Steel * 3-Hole Drive Shafts	C5B x 2	9" - 12"	355225	1	2.00	9.00	2.13	3.00	0.64	32.10
	C5B x 2-7/16	12" - 14"	355226	1	2.44	9.69	2.75	3.00	0.64	36.90
	C5B x 3	12" - 20"	355227	1	3.00	9.88	2.88	3.00	0.77	43.90
	C5B x 3-7/16	18" - 24"	355228	1	3.44	14.13	3.88	4.00	0.89	58.80

* Supplied as #316 stainless steel.

FEATURES/BENEFITS PAGE G2-3	NOMENCLATURE PAGE G2-11	SELECTION/DIMENSIONS PAGE G2-90	RELATED PRODUCTS PAGE G2-152
--------------------------------	----------------------------	------------------------------------	---------------------------------

MODIFICATIONS/ ACCESSORIES

DODGE®

Screw Conveyor Shaft Mount Speed Reducers SCXT SCREW CONVEYOR DRIVE OPTIONAL DRIVE SHAFTS (CONT'D)

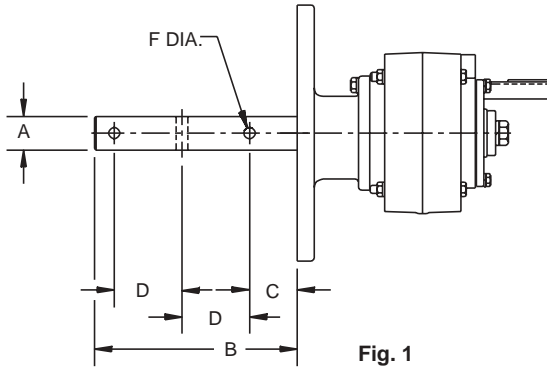

Fig. 1

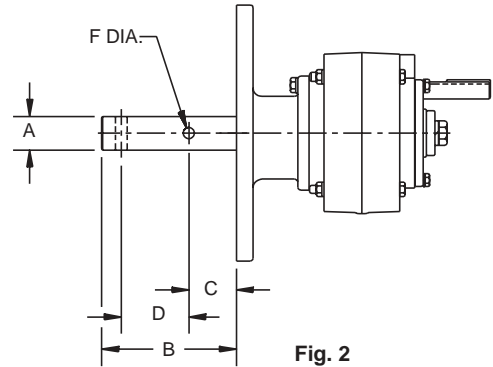

Fig. 2

SCXT6 Optional Drive Shafts

Description	Drive Shaft	Screw Dia.	Part No.	Figure	A	B	C	D	F	Weight
SCXT6 Stainless Steel * Drive Shafts	C6 x 2-7/16	12" - 14"	356014	2	2.44	6.69	2.75	3.00	0.64	47.7
	C6 x 3	12" - 20"	356015	2	3.00	6.88	2.88	3.00	0.77	52.7
	C6 x 3-7/16	18" - 24"	356016	2	3.44	9.13	3.88	4.00	0.89	63.0
SCXT6 3-Hole Drive Shafts	C6 x 2-7/16	12" - 14"	351327	1	2.44	9.69	2.75	3.00	0.64	51.6
	C6 x 3	12" - 20"	351328	1	3.00	9.88	2.88	3.00	0.77	58.7
	C6 x 3-7/16	18" - 24"	351329	1	3.44	14.13	3.88	4.00	0.89	73.5
SCXT6† Stainless Steel * 3-Hole Drive Shafts	C6 x 2-7/16	12" - 14"	356275	1	2.44	9.69	2.75	3.00	0.64	51.6
	C6 x 3	12" - 20"	356276	1	3.00	9.88	2.88	3.00	0.77	58.7
	C6 x 3-7/16	18" - 24"	356277	1	3.44	14.13	3.88	4.00	0.89	73.5

SCXT7 Optional Drive Shafts

Description	Drive Shaft	Screw Dia.	Part No.	Figure	A	B	C	D	F	Weight
SCXT7 Stainless Steel * Drive Shafts	C7 x 2-7/16	12" - 14"	356240	2	2.44	6.69	2.75	3.00	0.64	58.0
	C7 x 3	12" - 20"	356241	2	3.00	6.88	2.88	3.00	0.77	70.0
	C7 x 3-7/16	18" - 24"	356242	2	3.44	9.13	3.88	4.00	0.89	80.3
SCXT7 3-Hole Drive Shafts	C7 x 2-7/16	12" - 14"	351332	1	2.44	9.69	2.75	3.00	0.64	61.9
	C7 x 3	12" - 20"	351333	1	3.00	9.88	2.88	3.00	0.77	76.0
	C7 x 3-7/16	18" - 24"	351334	1	3.44	14.13	3.88	4.00	0.89	90.8
SCXT7 Stainless Steel *3-Hole Drive Shafts	C7 x 2-7/16	12" - 14"	356281	1	2.44	9.69	2.75	3.00	0.64	61.9
	C7 x 3	12" - 20"	356282	1	3.00	9.88	2.88	3.00	0.77	76.0
	C7 x 3-7/16	18" - 24"	356283	1	3.44	14.13	3.88	4.00	0.89	90.8

* Supplied as #316 stainless steel.

NOTE: See page G2-118 - G2-119 for dimensions and part numbers for drive shafts available for SCXT-8 Screw Conveyor Drives.

FEATURES/BENEFITS PAGE G2-3	NOMENCLATURE PAGE G2-11	SELECTION/DIMENSIONS PAGE G2-90	RELATED PRODUCTS PAGE G2-152
--------------------------------	----------------------------	------------------------------------	---------------------------------



Screw Conveyor Shaft Mount Speed Reducers SLOTTED METAL PANEL BELT GUARDS

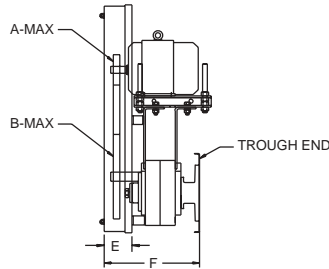
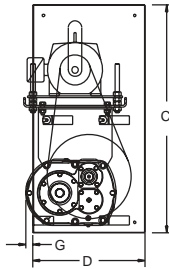

BELT GUARDS FOR DOUBLE REDUCTION SCXT REDUCERS (9, 15, 25:1) WITH STANDARD MOTOR MOUNTS

REDUCER SIZE	BELT GUARD SIZE	PART NUMBER	MOTOR MOUNT NO.	WT.	NEMA MOTOR FRAME	CENTER DISTANCE		A	B	C	D	E	F	G
						MIN.	MAX.							
SCXT1	SCXT1D	241489	M 112L	21	56T-215T	13.5	19.0	5.0	12.0	27.5	13.0	3.5	12.5	1.00
SCXT2	SCXT2D	242489	M 214L	32	56T-215T	14.9	20.0	5.0	12.0	30.0	14.0	3.8	13.5	0.875
SCXT3A	SCXT3D	243416 ▲	M 316L	40	56T-215T	15.8	22.0	6.0	14.0	32.5	16.0	4.0	14.6	1.06
SCXT4A	SCXT4D	244489	M 418L	44	143T-286T	16.9	24.5	7.0	15.0	37.0	17.0	5.0	16.8	1.78
SCXT5B	SCXT5D	245495 ▲	M 518L	45	143T-286T	16.6	25.2	7.0	15.0	37.0	18.0	4.3	18.9	3.25
SCXT6	SCXT6D	246476	M 620L	60	143T-326T	17.0	25.5	8.0	18.0	41.0	20.0	6.0	21.4	4.38
SCXT7	SCXT7D	247474	M 720L	75	143T-365T	17.1	26.0	10.0	20.0	43.0	23.0	6.0	23.5	6.25

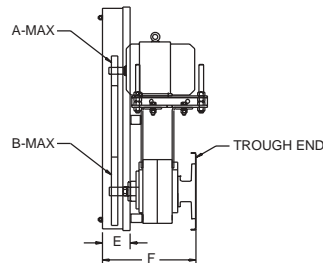
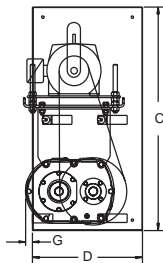

BELT GUARDS FOR SINGLE REDUCTION SCXT REDUCERS (5:1) WITH STANDARD MOTOR MOUNTS

REDUCER SIZE	BELT GUARD SIZE	PART NUMBER	MOTOR MOUNT NO.	WT.	NEMA MOTOR FRAME	CENTER DISTANCE		A	B	C	D	E	F	G
						MIN.	MAX.							
SCXT105	SCXT1S	241491	M 112	30	56T-215T	15.4	20.6	5.0 ■	12.0	31.0	13.50	3.50	12.50	0.38
SCXT205	SCXT2S	242491	M 214	34	56T-215T	17.0	22.2	6.0 ■	12.0	33.0	13.50	3.75	13.50	1.25
SCXT305A	SCXT3S	243418 ▲	M 316	40	56T-215T	18.2	24.4	7.0	12.0	35.0	13.50	4.00	14.63	2.38
SCXT405A	SCXT4S	244491	M 418	50	143T-286T	19.6	27.2	8.0	12.0	40.0	14.50	5.00	16.75	3.63
SCXT505A	SCXT5S	245497 ▲	M 518	70	143T-286T	19.7	28.2	8.0	12.0	40.0	14.50	5.50	18.91	5.68
SCXT605	SCXT6S	246478	M 620	77	143T-326T	21.1	29.6	10.0	16.0	45.0	18.00	6.00	21.44	5.97
SCXT705	SCXT7S	247476	M 720	84	143T-365T	22.1	31.0	10.0	16.0	45.5	19.00	6.00	23.53	9.25

- Guard will interfere with floor when used with 6" screw unless trough is raised above floor.
- ▲ These belt guards do not fit the larger frame, higher H.P. motor mounts in SCXT Selection/Dimension pages. Consult DODGE for special belt guard.

FEATURES/BENEFITS PAGE G2-3	NOMENCLATURE PAGE G2-11	SELECTION/DIMENSIONS PAGE G2-90	RELATED PRODUCTS PAGE G2-152
--------------------------------	----------------------------	------------------------------------	---------------------------------

MODIFICATIONS/ ACCESSORIES



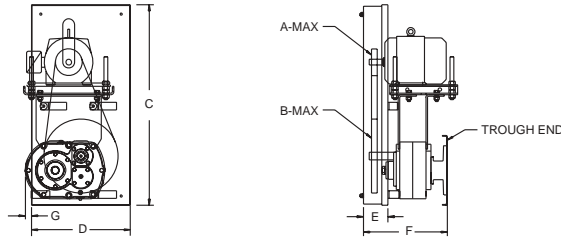

Screw Conveyor Shaft Mount Speed Reducers SLOTTED METAL PANEL BELT GUARDS

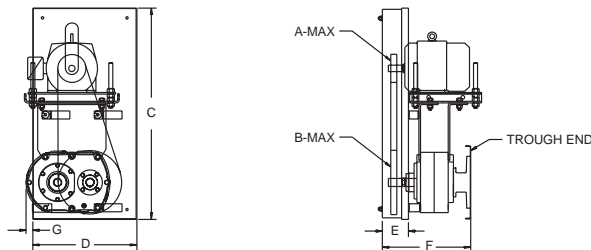

BELT GUARDS FOR DOUBLE REDUCTION SCXT REDUCERS (9, 15, 25:1) WITH LONG MOTOR MOUNTS

REDUCER SIZE	BELT GUARD SIZE	PART NUMBER	MOTOR MOUNT NO.	WT.	NEMA MOTOR FRAME	CENTER DISTANCE		A	B	C	D	E	F	G
						MIN.	MAX.							
SCXT1	SCXT1DLMM	241149	M120L	26	56T-215T	19.5	25.0	5.0	12.0	33.5	13.0	3.50	12.50	1.00
SCXT2	SCXT2DLMM	242223	M220L	37	56T-215T	20.9	26.0	5.0	12.0	36.0	14.0	3.75	13.50	0.875
SCXT3A	SCXT3DLMM	243154 ▲	M320L	45	56T-215T	21.8	27.0	6.0	14.0	38.0	16.0	4.00	14.63	1.06
SCXT4A	SCXT4DLMM	244152 ▲	M424L	50	143T-286T	23.2	30.4	7.0	15.0	43.0	17.0	5.00	16.75	1.78
SCXT5B	SCXT5DLMM	245103 ▲	M524L	52	143T-286T	22.9	30.9	7.0	15.0	43.0	18.0	4.25	18.91	3.25
SCXT6	SCXT6DLMM	246148	M624L	65	143T-326T	23.3	31.4	8.0	18.0	47.0	20.0	6.00	21.44	4.38
SCXT7	SCXT7DLMM	247153 ▲	M724L	80	143T-326T	23.2	30.5	10.0	20.0	49.0	23.0	6.00	23.53	6.25
SCXT8	SCXT8DLMM	248477 ♣	M824L	113	210T-360T	23.3	32.1	12.0	25.0	53.0	28.0	6.50	24.81	5.62



BELT GUARDS FOR SINGLE REDUCTION SCXT REDUCERS (5:1) WITH LONG MOTOR MOUNTS ♣

REDUCER SIZE	BELT GUARD SIZE	PART NUMBER	MOTOR MOUNT NO.	WT.	NEMA MOTOR FRAME	CENTER DISTANCE		A	B	C	D	E	F	G
						MIN.	MAX.							
SCXT105	SCXT1SLMM	241142	M120L	35	56T-215T	21.4	26.6	5.0 ■	12.0	37.0	13.5	3.50	12.50	0.38
SCXT205	SCXT2SLMM	242114	M220L	40	56T-215T	23.3	28.2	6.0 ■	12.0	39.0	13.5	3.75	13.50	1.25
SCXT305A	SCXT3SLMM	243167 ▲	M320L	45	56T-215T	24.2	29.4	7.0	12.0	41.0	13.5	4.00	14.63	2.38
SCXT405A	SCXT4SLMM	244167 ▲	M424L	55	143T-286T	25.9	33.2	8.0	12.0	46.0	14.5	5.00	16.75	3.63
SCXT505A	SCXT5SLMM	245015 ▲	M524L	70	143T-286T	26.0	33.2	8.0	12.0	46.0	14.5	5.50	18.91	5.68
SCXT605	SCXT6SLMM	246142	M624L	82	143T-326T	27.4	35.5	10.0	16.0	51.0	18.0	6.00	21.44	5.97
SCXT705	SCXT7SLMM	247149	M724L	90	143T-326T	28.2	35.6	10.0	16.0	51.5	19.0	6.00	23.53	9.25

■ Guard will interfere with floor when used with 6, screw unless trough is raised above floor.

▲ These belt guards do not fit the larger frame, higher H.P. motor mounts in SCXT Selection/Dimension pages.
Consult DODGE for special belt guard.

♣ Made to order.

FEATURES/BENEFITS PAGE G2-3	NOMENCLATURE PAGE G2-11	SELECTION/DIMENSIONS PAGE G2-90	RELATED PRODUCTS PAGE G2-152
--------------------------------	----------------------------	------------------------------------	---------------------------------



Screw Conveyor Shaft Mount Speed Reducers AUXILIARY SEAL KIT FOR SCREW CONVEYOR DRIVE REDUCERS

Screw conveyor drives often operate in harsh environments in which the input shaft side of the reducer ends up turning in such materials as sand, cement, saw dust and grain. These materials are very abrasive and often damage seals, bearings and gears. These damages can lead to costly repair bills and downtime. To help prevent these maintenance problems DODGE offers an Auxiliary Seal Kit to protect the input side of the

reducer. The kit contains a drive shaft end cover, special filter breather and a grease purged input seal with necessary mounting hardware. The auxiliary seals prevent contaminants from getting to the seal area and thus prevents them from entering the reducer. Use the auxiliary seal kit to get the longest possible life out of your DODGE Screw Conveyor Drive Reducer.

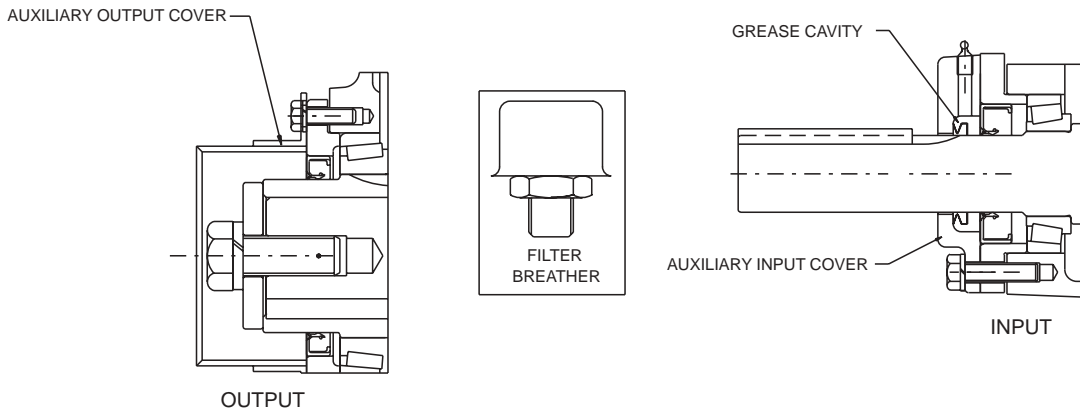

SCXT Auxiliary Seal Kits ●

Reducer Size	Nominal Ratio	Part Number	Nominal Ratio	Part Number ♣
SCXT1	9, 15, 25	272721	5	251146
SCXT2	9, 15, 25	272722	5	252146
SCXT3A	9, 15, 25	243582	5	253146
SCXT4A	9, 15, 25	244677	5	254146
SCXT5A/SCXT5B	9, 15, 25	245637	5	255148
SCXT6	5, 9, 15, 25	272726	-	-
SCXT7	5, 9, 15, 25	272727	-	-
SCXT8	15, 25	248484 ♣	-	-

♣ Made to order.

● An input auxiliary seal cannot be used on the same input shaft with a cooling fan

FEATURES/BENEFITS PAGE G2-3	NOMENCLATURE PAGE G2-11	SELECTION/DIMENSIONS PAGE G2-90	RELATED PRODUCTS PAGE G2-152
--------------------------------	----------------------------	------------------------------------	---------------------------------

SELECTION



TORQUE-ARM Shaft Mount Speed Reducers EASY SELECTION METHOD (FOR HYDRAULIC MOTORS)

When to Use Easy Selection

The Easy Selection tables for HXT Shaft Mount reducers are for hydraulic motor selections up to approximately horsepower with output speeds up to 400 RPM, using AGMA recommended application class numbers. For extreme repetitive shock loads, consult DODGE Application Engineering, (864) 288-9050.

How to Select

Step 1: Determine Class of Service-See Table 1, G2-15 to determine Load Classification for applications under normal conditions. Find the type application and duty cycle that most closely matches your specific application.

Class I Steady load not exceeding Motor HP rating and light shock loads during 10 hours a day. Moderate shock loads are allowable if operation is intermittent.

For Class I applications, the maximum value of starting and momentary peak loads should not exceed 2 x Motor HP rating. If it exceeds this amount it should be divided by 2 and the result used in the selection table instead of the Motor HP rating.

Class II Steady load not exceeding Motor HP rating for over 10 hours a day. Moderate shock loads are allowable during 10 hours a day.

For Class II applications, the maximum value of starting and momentary peak loads should not exceed 2.8 x Motor HP rating. If it exceeds this amount it should be divided by 2.8 and the result used in the selection table instead of the Motor HP rating.

Class III Moderate shock loads for over 10 hours a day. Heavy shock loads are allowable during 10 hours a day.

For Class III applications, the maximum value of starting and momentary peak loads should not exceed 4 x Motor HP rating. If it exceeds this amount it should be divided by 4 and the result used in the selection table instead of the Motor HP rating.

Step 2: Determine Reducer Size-See the Easy Selection Tables, pages G2-128 thru G2-142. From Selection Table I, II or III read the reducer size for the application horsepower and output speed. Also compare the reducer/motor running and starting torque, running pressure and flow rate with that required for the application. See Table 18, page G2-143 for maximum hydraulic motor starting pressure for HYDROIL Vane Motors.

Step 3: Compare Hollow Shaft Bore with the size of the driven shaft. All DODGE TORQUE-ARM Taper Bushed reducers require bushings. Refer to TXT reducer pages for available bushings. If the driven shaft is larger than the bore of the selected reducer, the shaft must be machined to the proper size, or select a larger reducer. Check driven shaft and key for strength.

Step 4: Check Dimensions-See Selection/Dimensions sections, pages G2-144 thru G2-147 for reducer dimensions, weights and part numbers. See Engineering/Technical section, pages G2-199 and G2-213 for reducer and torque-arm rod mounting positions.

Step 5: Select a Hydroil Vane Motor-See Selection/Dimensions pages for listing of HYDROIL Vane Motors required to drive each size and ratio of HXT reducer. See page G2-151 for dimensions and part numbers. **Note: 100 RPM is minimum speed for Hydroil Vane Motors.**



TORQUE-ARM Shaft Mount Speed Reducers

Note: A Torque-Arm rod assembly is furnished with all HXT reducers, unless otherwise specified. Torque-Arm reducers are shipped without oil.

Ratings and selections are the same for both taper bushed and straight bore HXT reducers.

EXAMPLE: EASY SELECTION METHOD-HXT TORQUE-ARM REDUCER

A 3HP motor is used to drive the head shaft on a heavily loaded bucket elevator at 30 RPM, 16 hours per day. Head shaft diameter is 2-3/16". User wants to use a hydraulic motor as prime mover since drive is not in an easily accessible location.

Step 1: Determine Class of Service-From Table 1, page G2-15 locate "bucket elevators, heavily loaded" for over 10 hours per day. This load will be classified as a Class II application.

Step 2: Determine Reducer Size-From Table 13 -Class II Application, page G2-128, find the 30 RPM output column at the top of the table. Read down to the HP rating of 3HP or greater. At 3.6HP, trace to the far left column to find that the basic reducer size for the application is an HXT3. Either an HXT315 or an HXT325 may be used, depending on the starting torque requirements.

Step 3: Compare Hollow Shaft Bore of an HXT315/325 with the application driven shaft diameter. Per page

G2-144, 2-3/16" is the maximum bore available for this size reducer, so it will work in this application. Select reducer bushing from part numbers listed with TXT reducers on page G2-28. Be sure to check driven shaft and key for strength.

Step 4: Check Dimensions and Weights-See Selection/Dimensions section, page, for reducer dimensions, weights, part numbers and other pertinent drive dimensions. See Engineering/Technical section, pages G2-199 and G2-213 for information on reducer and torque-arm rod mounting positions.

Step 5: Select a Hydroil Vane Motor-See Selection/Dimension pages. Trace from Reducer size HXT315 right to column labeled Hydroil Motor. It must be driven by a size B30 Hydroil Vane Motor. Likewise a reducer size HXT325 is designed to be driven by an A20 Hydroil Vane Motor. See page G2-151 for the motor part numbers and dimensions.

FEATURES/BENEFITS PAGE G2-3	NOMENCLATURE PAGE G2-11	SELECTION/DIMENSIONS PAGE G2-90	RELATED PRODUCTS PAGE G2-152
--------------------------------	----------------------------	------------------------------------	---------------------------------

EASY SELECTIONS



HYDROIL TORQUE-ARM Shaft Mount Speed Reducers

TABLE 12 - CLASS I SELECTION TABLE HXT REDUCERS - DOUBLE REDUCTION

HXT-115 - HXT425A

Reducer Size	Requirements ★	Output Speed										
		10	15	20	25	30	35	40	45	50	55	60
HXT-115	OUTPUT HP(RUN)	0.6	0.9	1.2	1.4	1.7	1.9	2.2	2.4	2.7	2.9	3.1
	Running Torque	4025	3776	3651	3577	3527	3491	3465	3396	3342	3298	3260
	Starting Torque	4025	4025	4025	4025	4025	4025	4025	4025	4025	4025	4025
	Running Pressure	1685	1581	1529	1498	1477	1462	1451	1422	1399	1381	1365
	Flow Rate, GPM	2.0	2.3	2.7	3.0	3.4	3.8	4.1	4.5	4.9	5.2	5.6
HXT-125	OUTPUT HP(RUN)	0.5	0.8	1.1	1.3	1.6	1.9	2.2	2.4	2.7	2.9	3.1
	Running Torque	3403	3403	3403	3403	3403	3403	3403	3396	3342	3298	3260
	Starting Torque	2868	2868	2868	2868	2868	2868	2868	2868	2868	2868	2868
	Running Pressure	2000	2000	2000	2000	2000	2000	2000	1996	1964	1938	1916
	Flow Rate, GPM	1.5	1.8	2.1	2.3	2.6	2.9	3.2	3.4	3.7	3.9	4.2
HXT-215	OUTPUT HP(RUN)	0.7	1.0	1.4	1.7	2.1	2.4	2.8	3.1	3.5	3.8	4.2
	Running Torque	4387	4387	4387	4387	4387	4387	4387	4387	4387	4387	4387
	Starting Torque	3697	3697	3697	3697	3697	3697	3697	3697	3697	3697	3697
	Running Pressure	2000	2000	2000	2000	2000	2000	2000	2000	2000	2000	2000
	Flow Rate, GPM	2.2	2.6	2.9	3.3	3.6	4.0	4.3	4.7	5.0	5.4	5.7
HXT-225	OUTPUT HP(RUN)	1.1	1.6	2.1	2.6	3.0	3.5	4.0	4.4	4.8	5.2	5.6
	Running Torque	7245	6824	6613	6486	6402	6342	6297	6171	6070	5988	5919
	Starting Torque	6152	6152	6152	6152	6152	6152	6152	6152	6152	6152	6152
	Running Pressure	1985	1870	1812	1777	1754	1737	1725	1691	1663	1640	1622
	Flow Rate, GPM	2.7	3.2	3.7	4.3	4.8	5.4	6.0	6.5	7.1	7.6	8.2
HXT-315A	OUTPUT HP(RUN)	1.8	2.6	3.4	4.3	5.1	5.9	6.8	7.4	8.1	8.7	9.4
	Running Torque	11098	10894	10791	10730	10689	10660	10638	10379	10171	10001	9860
	Starting Torque	17190	17190	17190	17190	17190	17190	17190	17190	17190	17190	17190
	Running Pressure	1523	1495	1481	1473	1467	1463	1460	1425	1396	1373	1353
	Flow Rate, GPM	4.6	5.7	6.9	8.0	9.2	10.3	11.5	12.6	13.7	14.8	15.9
HXT-325A	OUTPUT HP(RUN)	1.2	1.8	2.4	3.0	3.7	4.3	4.9	5.5	6.1	6.7	7.3
	Running Torque	7689	7689	7689	7689	7689	7689	7689	7689	7689	7689	7689
	Starting Torque	6479	6479	6479	6479	6479	6479	6479	6479	6479	6479	6479
	Running Pressure	2000	2000	2000	2000	2000	2000	2000	2000	2000	2000	2000
	Flow Rate, GPM	2.7	3.4	4.0	4.6	5.2	5.8	6.4	7.0	7.6	8.3	8.9
HXT-415A	OUTPUT HP(RUN)	2.6	3.9	5.1	6.3	7.5	8.7	9.9	11.0	12.1	13.1	14.2
	Running Torque	16676	16229	16005	15871	15781	15717	15669	15424	15227	15066	14932
	Starting Torque	17479	17479	17479	17479	17479	17479	17479	17479	17479	17479	17479
	Running Pressure	2251	2191	2161	2142	2130	2122	2115	2082	2056	2034	2016
	Flow Rate, GPM	5.7	6.8	8.0	9.1	10.3	11.4	12.6	13.7	14.9	16.0	17.2
HXT-425A	OUTPUT HP(RUN)	2.6	3.9	5.1	6.3	7.5	8.7	9.9	11.0	12.1	13.1	14.2
	Running Torque	16676	16229	16005	15871	15781	15717	15669	15424	15227	15066	14932
	Starting Torque	28164	28164	28164	28164	28164	28164	28164	28164	28164	28164	28164
	Running Pressure	1397	1360	1341	1330	1322	1317	1313	1292	1276	1262	1251
	Flow Rate, GPM	5.9	7.7	9.6	11.5	13.4	15.3	17.2	19.0	20.9	22.8	24.7

★ See page G2-143 for definition of requirements.

FEATURES/BENEFITS PAGE G2-3	NOMENCLATURE PAGE G2-11	SELECTION/DIMENSIONS PAGE G2-144	RELATED PRODUCTS PAGE G2-152
--------------------------------	----------------------------	-------------------------------------	---------------------------------



HYDROIL TORQUE-ARM Shaft Mount Speed Reducers

TABLE 12 - CLASS I SELECTION TABLE HXT REDUCERS - DOUBLE REDUCTION

HXT-115 - HXT425A (CONT'D)

Reducer Size	Output Speed															
	65	70	75	80	85	90	95	100	105	110	115	120	125	130	135	140
HXT-115	3.3	3.6	3.8	4.0	4.2	4.5	4.7	4.9	5.1	5.3	5.5	5.7	5.9	6.1	6.3	6.50
	3229	3202	3179	3158	3140	3124	3099	3076	3056	3037	3020	3005	2983	2964	2945	2929
	4025	4025	4025	4025	4025	4025	4025	4025	4025	4025	4025	4025	4025	4025	4025	4025
	1352	1341	1331	1322	1315	1308	1298	1288	1280	1272	1265	1258	1249	1241	1233	1226
	6.0	6.3	6.7	7.1	7.5	7.8	8.2	8.6	9.0	9.3	9.7	10.1	10.5	10.8	11.2	11.6
HXT-125	3.3	3.6	3.8	4.0	4.2											
	3229	3202	3179	3158	3140											
	2868	2868	2868	2868	2868											
	1898	1882	1868	1856	1845											
	4.5	4.7	5.0	5.2	5.5											
HXT-215	4.5	4.9	5.2	5.6	5.9	6.3	6.6	7.0	7.3	7.7	8.0	8.4	8.7	9.0	9.4	9.7
	4387	4387	4387	4387	4387	4387	4387	4387	4387	4387	4387	4387	4387	4387	4387	4387
	3697	3697	3697	3697	3697	3697	3697	3697	3697	3697	3697	3697	3697	3697	3697	3697
	2000	2000	2000	2000	2000	2000	2000	2000	2000	2000	2000	2000	2000	2000	2000	2000
	6.1	6.4	6.8	7.1	7.5	7.8	8.2	8.5	8.9	9.2	9.6	9.9	10.3	10.6	11.0	11.3
HXT-225	6.0	6.5	6.9	7.3	7.7											
	5861	5811	5768	5730	5697											
	6152	6152	6152	6152	6152											
	1606	1592	1580	1570	1561											
	8.8	9.3	9.9	10.5	11.1											
HXT-315A	10.0	10.7	11.4	12.0	12.7	13.3	13.8	14.3	14.8	15.3	15.8	15.9	15.7	15.5	15.2	15.0
	9740	9637	9549	9471	9402	9341	9172	9020	8883	8758	8644	8351	7916	7515	7096	6753
	17190	17190	17190	17190	17190	17190	17190	17190	17190	17190	17190	17078	16862	16663	16478	16306
	1337	1323	1311	1300	1291	1282	1259	1238	1219	1202	1186	1146	1087	1031	974	927
	17.1	18.2	19.4	20.5	21.7	22.8	23.9	25.1	26.2	27.3	28.5	29.6	30.6	31.7	32.8	33.9
HXT-325A	7.9	8.5	9.1	9.8	10.4											
	7689	7689	7689	7689	7689											
	6479	6479	6479	6479	6479											
	2000	2000	2000	2000	2000											
	9.5	10.1	10.7	11.3	11.9											
HXT-415A	15.3	16.3	17.4	18.5	19.6	20.6	21.5	22.0	21.5	21.0	20.5	20.0	19.5	19.0	18.5	18.0
	14818	14721	14636	14563	14497	14440	14295	13866	12905	12032	11235	10504	9832	9211	8637	8103
	17479	17479	17479	17479	17479	17479	17479	17479	17479	17479	17479	17479	17479	17479	17479	17479
	2000	1987	1976	1966	1957	1949	1930	1872	1742	1624	1517	1418	1327	1244	1166	1094
	18.30	19.5	20.7	21.8	23.0	24.1	25.3	26.4	27.4	28.4	29.4	30.4	31.5	32.5	33.6	34.7
HXT-425A	15.30	16.3	17.4	18.5	19.6											
	14818	14721	14636	14563	14497											
	28164	28164	28164	28164	28164											
	1241	1233	1226	1220	1215											
	26.6	28.5	30.3	32.2	34.1											

FEATURES/BENEFITS PAGE G2-3	NOMENCLATURE PAGE G2-11	SELECTION/DIMENSIONS PAGE G2-144	RELATED PRODUCTS PAGE G2-152
--------------------------------	----------------------------	-------------------------------------	---------------------------------

EASY SELECTIONS



HYDROIL TORQUE-ARM Shaft Mount Speed Reducers

TABLE 12 - CLASS I SELECTION TABLE HXT REDUCERS - DOUBLE REDUCTION

HXT-515B - HXT-725

Reducer Size	Requirements ★	Output Speed										
		10	15	20	25	30	35	40	45	50	55	60
HXT-515B	OUTPUT HP(RUN)	4.6	6.5	8.5	10.5	12.5	14.4	16.4	17.9	19.3	20.8	22.3
	Running Torque	28751	27474	26835	26451	26196	26013	25876	25046	24381	23838	23384
	Starting Torque	31924	31924	31924	31924	31924	31924	31924	31924	31924	31924	31924
	Running Pressure	2125	2031	1983	1955	1936	1923	1913	1851	1802	1762	1728
	Flow Rate, GPM	10.0	11.9	13.9	16.0	18.1	20.2	22.3	24.3	26.3	28.4	30.5
HXT-525B	OUTPUT HP(RUN)	4.6	6.5	8.5	10.5	12.5	14.4	16.4	17.9	19.3	20.8	22.3
	Running Torque	28751	27474	26835	26451	26196	26013	25876	25046	24381	23838	23384
	Starting Torque	29528	29528	29528	29528	29528	29528	29528	29528	29528	29528	29528
	Running Pressure	2298	2195	2144	2114	2093	2079	2068	2001	1948	1905	1869
	Flow Rate, GPM	7.4	9.3	11.2	13.1	15.1	17.1	19.0	20.9	22.8	24.8	26.7
HXT-615	OUTPUT HP(RUN)	5.3	8.0	10.7	13.4	16.0	18.7	21.4	24.0	26.7	29.4	32.1
	Running Torque	33671	33671	33671	33671	33671	33671	33671	33671	33671	33671	33671
	Starting Torque	31779	31779	31779	31779	31779	31779	31779	31779	31779	31779	31779
	Running Pressure	2500	2500	2500	2500	2500	2500	2500	2500	2500	2500	2500
	Flow Rate, GPM	11.0	13.1	15.3	17.4	19.5	21.7	23.8	26.0	28.1	30.3	32.4
HXT-625	OUTPUT HP(RUN)	7.2	10.4	13.7	16.9	20.1	23.3	26.6	29.1	31.6	34.1	36.6
	Running Torque	45427	43830	43031	42552	42233	42004	41833	40699	39792	39050	38431
	Starting Torque	52094	52094	52094	52094	52094	52094	52094	52094	52094	52094	52094
	Running Pressure	2058	1985	1949	1927	1913	1903	1895	1843	1802	1769	1741
	Flow Rate, GPM	12.5	15.8	19.3	22.7	26.2	29.7	33.2	36.6	40.0	43.4	46.8
HXT-715	OUTPUT HP(RUN)	9.6	14.4	19.2	23.8	28.3	32.9	37.4	41.4	45.3	49.3	53.2
	Running Torque	60533	60533	60533	59918	59483	59173	58940	57937	57135	56478	55931
	Starting Torque	57132	57132	57132	57132	57132	57132	57132	57132	57132	57132	57132
	Running Pressure	2500	2500	2500	2475	2457	2444	2434	2393	2360	2333	2310
	Flow Rate, GPM	12.7	16.6	20.4	24.2	28.0	31.9	35.7	39.5	43.3	47.1	50.9
HXT-725	OUTPUT HP(RUN)	8.6	12.9	17.1	21.4	25.7	30.0	34.3	38.6	42.8	47.1	51.4
	Running Torque	54009	54009	54009	54009	54009	54009	54009	54009	54009	54009	54009
	Starting Torque	50975	50975	50975	50975	50975	50975	50975	50975	50975	50975	50975
	Running Pressure	2500	2500	2500	2500	2500	2500	2500	2500	2500	2500	2500
	Flow Rate, GPM	13.6	17.0	20.4	23.9	27.3	30.7	34.2	37.6	41.1	44.5	47.9

★ See page G2-143 for definition of requirements.



HYDROIL TORQUE-ARM Shaft Mount Speed Reducers

TABLE 12 - CLASS I SELECTION TABLE HXT REDUCERS - DOUBLE REDUCTION
HXT-515B - HXT-725 (CONT'D)

Reducer Size	Output Speed															
	65	70	75	80	85	90	95	100	105	110	115	120	125	130	135	140
HXT-515B	23.7	24.8	24.2	23.5	22.9	22.3	21.7	21.1	20.5	19.8	19.2	18.6	18.0			
	23001	22329	20336	18514	16980	15616	14396	13298	12305	11345	10522	9769	9076			
	31924	31924	31924	31924	31924	31924	31924	31924	31924	31924	31924	31924	31924			
	1700	1650	1503	1368	1255	1154	1064	983	909	838	778	722	671			
	32.5	34.6	36.3	38.1	40.0	41.8	43.8	45.7	47.7	49.6	51.6	53.6	55.6			
HXT-525B	23.7	24.8	24.2	23.5												
	23001	22329	20336	18514												
	29528	29528	29528	29528												
	1838	1784	1625	1479												
	28.7	30.6	32.3	34.1												
HXT-615	34.7	37.4	39.6	37.6	35.7	33.7	31.8	29.8	27.8	25.9	23.9	22.0	20.0			
	33671	33671	33277	29622	26471	23599	21097	18781	16687	14840	13098	11555	10084			
	31779	31779	31779	31779	31779	31779	31779	31779	31779	31779	31779	31779	31779			
	2500	2500	2471	2199	1965	1752	1566	1395	1239	1102	973	858	749			
	34.5	36.7	38.8	40.2	41.7	43.3	44.9	46.6	48.3	50.1	51.9	53.7	55.6			
HXT-625	39.1	41.5	39.6	37.6												
	37908	37365	33277	29622												
	52094	52094	52094	52094												
	1717	1692	1507	1342												
	50.3	53.7	56.7	59.8												
HXT-715	57.2	55.6	53.5	51.4	49.3	47.2	45.0	43.0	41.0	39.0	37.0	35.0				
	55468	50060	44958	40494	36555	33053	29854	27101	24610	22345	20278	18382				
	57132	57132	57132	57132	57132	57132	57132	57132	57132	57132	57132	57132				
	2291	2067	1857	1672	1510	1365	1233	1119	1016	923	837	759				
	54.7	58.1	61.5	65.0	68.5	72.1	75.7	79.3	83.0	86.6	90.3	94.0				
HXT-725	55.7	55.6	53.5													
	54009	50060	44958													
	50975	50975	50975													
	2500	2317	2081													
	51.4	54.3	57.1													

Gearing Reference Guide

TORQUE-ARM II

TORQUE-ARM

MAXIMUM Concentric Reducer

TIGEAR-2

EASY SELECTIONS



HYDROIL TORQUE-ARM Shaft Mount Speed Reducers

TABLE 13 - CLASS II SELECTION TABLE HXT REDUCERS - DOUBLE REDUCTION

HXT-115 - HXT-425A

Reducer Size	Requirements ★	Output Speed										
		10	15	20	25	30	35	40	45	50	55	60
HXT-115	OUTPUT HP(RUN)	0.5	0.6	0.8	1.0	1.2	1.4	1.6	1.7	1.9	2.1	2.2
	Running Torque	2875	2697	2608	2555	2519	2494	2475	2426	2387	2355	2329
	Starting Torque	4025	4025	4025	4025	4025	4025	4025	4025	4025	4025	4025
	Running Pressure	1204	1129	1092	1070	1055	1044	1036	1016	1000	986	975
	Flow Rate, GPM	1.7	2.0	2.4	2.7	3.1	3.5	3.8	4.2	4.6	4.9	5.3
HXT-125	OUTPUT HP(RUN)	0.5	0.6	0.8	1.0	1.2	1.4	1.6	1.7	1.9	2.1	2.2
	Running Torque	2875	2697	2608	2555	2519	2494	2475	2426	2387	2355	2329
	Starting Torque	2868	2868	2868	2868	2868	2868	2868	2868	2868	2868	2868
	Running Pressure	1690	1585	1533	1501	1480	1465	1454	1426	1403	1384	1369
	Flow Rate, GPM	1.4	1.6	1.8	2.1	2.4	2.6	2.9	3.1	3.4	3.7	3.9
HXT-215	OUTPUT HP(RUN)	0.7	1.0	1.4	1.7	2.1	2.4	2.8	3.1	3.4	3.7	4.0
	Running Torque	4387	4387	4387	4387	4387	4387	4387	4387	4336	4277	4228
	Starting Torque	3697	3697	3697	3697	3697	3697	3697	3697	3697	3697	3697
	Running Pressure	2000	2000	2000	2000	2000	2000	2000	2000	1976	1950	1927
	Flow Rate, GPM	2.2	2.6	2.9	3.3	3.6	4.0	4.3	4.7	5.0	5.3	5.7
HXT-225	OUTPUT HP(RUN)	0.8	1.2	1.5	1.8	2.2	2.5	2.9	3.1	3.4	3.7	4.0
	Running Torque	5175	4874	4723	4633	4573	4530	4498	4408	4336	4277	4228
	Starting Torque	6152	6152	6152	6152	6152	6152	6152	6152	6152	6152	6152
	Running Pressure	1418	1335	1294	1269	1253	1241	1232	1208	1188	1172	1158
	Flow Rate, GPM	2.2	2.8	3.3	3.9	4.4	5.0	5.6	6.2	6.7	7.3	7.9
HXT-315A	OUTPUT HP(RUN)	1.3	1.9	2.4	3.0	3.6	4.2	4.8	5.3	5.8	6.2	6.7
	Running Torque	7927	7781	7708	7664	7635	7614	7599	7413	7265	7144	7043
	Starting Torque	17190	17190	17190	17190	17190	17190	17190	17190	17190	17190	17190
	Running Pressure	1088	1068	1058	1052	1048	1045	1043	1018	997	981	967
	Flow Rate, GPM	4.0	5.1	6.2	7.4	8.5	9.7	10.8	12.0	13.1	14.2	15.4
HXT-325A	OUTPUT HP(RUN)	1.2	1.8	2.4	3.0	3.6	4.2	4.8	5.3	5.8	6.2	6.7
	Running Torque	7689	7689	7689	7664	7635	7614	7599	7413	7265	7144	7043
	Starting Torque	6479	6479	6479	6479	6479	6479	6479	6479	6479	6479	6479
	Running Pressure	2000	2000	2000	1994	1986	1981	1977	1928	1890	1858	1832
	Flow Rate, GPM	2.7	3.4	4.0	4.6	5.2	5.8	6.4	7.0	7.6	8.1	8.7
HXT-415A	OUTPUT HP(RUN)	1.9	2.8	3.6	4.5	5.4	6.2	7.1	7.9	8.6	9.4	10.2
	Running Torque	11911	11592	11432	11336	11272	11227	11192	11017	10876	10761	10665
	Starting Torque	17479	17479	17479	17479	17479	17479	17479	17479	17479	17479	17479
	Running Pressure	1608	1565	1543	1530	1522	1516	1511	1487	1468	1453	1440
	Flow Rate, GPM	4.8	5.9	7.0	8.2	9.4	10.5	11.7	12.8	14.0	15.2	16.3
HXT-425A	OUTPUT HP(RUN)	1.9	2.8	3.6	4.5	5.4	6.2	7.1	7.9	8.6	9.4	10.2
	Running Torque	11911	11592	11432	11336	11272	11227	11192	11017	10876	10761	10665
	Starting Torque	28164	28164	28164	28164	28164	28164	28164	28164	28164	28164	28164
	Running Pressure	998	971	958	950	944	941	938	923	911	902	894
	Flow Rate, GPM	5.3	7.2	9.0	10.9	12.8	14.7	16.6	18.5	20.4	22.3	24.1

★ See page G2-143 for definition of requirements.

FEATURES/BENEFITS PAGE G2-3	NOMENCLATURE PAGE G2-11	SELECTION/DIMENSIONS PAGE G2-144	RELATED PRODUCTS PAGE G2-152
--------------------------------	----------------------------	-------------------------------------	---------------------------------



HYDROIL TORQUE-ARM Shaft Mount Speed Reducers

TABLE 13 - CLASS II SELECTION TABLE HXT REDUCERS - DOUBLE REDUCTION

HXT-115 - HXT-425A

Reducer Size	Output Speed															
	65	70	75	80	85	90	95	100	105	110	115	120	125	130	135	140
HXT-115	2.40	2.50	2.70	2.90	3.00	3.20	3.30	3.50	3.60	3.80	3.90	4.10	4.20	4.40	4.50	4.60
	2306	2287	2271	2256	2243	2232	2214	2197	2183	2169	2157	2146	2131	2117	2104	2092
	4025	4025	4025	4025	4025	4025	4025	4025	4025	4025	4025	4025	4025	4025	4025	4025
	966	958	951	945	939	934	927	920	914	908	903	899	892	886	881	876
	5.7	6.1	6.4	6.8	7.2	7.6	7.9	8.3	8.7	9.1	9.4	9.8	10.2	10.6	10.9	11.3
HXT-125	2.4	2.5	2.7	2.9	3.0											
	2306	2287	2271	2256	2243											
	2868	2868	2868	2868	2868											
	1355	1344	1334	1326	1318											
	4.2	4.5	4.7	5.0	5.3											
HXT-215	4.3	4.6	4.9	5.2	5.5	5.8	6.0	6.3	6.6	6.8	7.1	7.4	7.6	7.9	8.2	8.4
	4186	4151	4120	4093	4069	4048	4010	3976	3945	3917	3891	3868	3847	3828	3810	3793
	3697	3697	3697	3697	3697	3697	3697	3697	3697	3697	3697	3697	3697	3697	3697	3697
	1908	1892	1878	1866	1855	1845	1828	1812	1798	1786	1774	1763	1754	1745	1737	1729
	6.0	6.3	6.7	7.0	7.4	7.7	8.0	8.4	8.7	9.0	9.4	9.7	10.1	10.4	10.8	11.1
HXT-225	4.3	4.6	4.9	5.2	5.5											
	4186	4151	4120	4093	4069											
	6152	6152	6152	6152	6152											
	1147	1137	1129	1121	1115											
	8.4	9.0	9.6	10.2	10.7											
HXT-315A	7.2	7.6	8.1	8.6	9.1	9.5	9.9	10.2	10.6	10.9	11.3	11.6	11.9	12.3	12.6	12.9
	6957	6884	6820	6765	6716	6672	6552	6443	6345	6256	6174	6099	6022	5951	5885	5824
	17190	17190	17190	17190	17190	17190	17190	17190	17190	17190	17190	17078	16862	16663	16478	16306
	955	945	936	929	922	916	899	884	871	859	847	837	827	817	808	799
	16.5	17.7	18.8	20.0	21.1	22.2	23.4	24.5	25.7	26.8	27.9	29.1	30.2	31.4	32.5	33.7
HXT-325A	7.2	7.6	8.1	8.6	9.1											
	6957	6884	6820	6765	6716											
	6479	6479	6479	6479	6479											
	1810	1791	1774	1760	1747											
	9.3	9.9	10.5	11.1	11.7											
HXT-415A	10.9	11.7	12.4	13.2	14.0	14.7	15.4	16.1	16.7	17.4	18.0	18.7	19.2	19.0	18.5	18.0
	10584	10515	10455	10402	10355	10314	10211	10118	10034	9957	9887	9823	9693	9211	8637	8103
	17479	17479	17479	17479	17479	17479	17479	17479	17479	17479	17479	17479	17479	17479	17479	17479
	1429	1419	1411	1404	1398	1392	1378	1366	1355	1344	1335	1326	1309	1244	1166	1094
	17.5	18.6	19.8	21.0	22.1	23.3	24.5	25.6	26.8	28.0	29.1	30.3	31.4	32.5	33.6	34.7
HXT-425A	10.9	11.7	12.4	13.2	14.0											
	10584	10515	10455	10402	10355											
	28164	28164	28164	28164	28164											
	887	881	876	871	868											
	26.0	27.9	29.8	31.7	33.6											

Gearing Reference Guide

TORQUE-ARM II

TORQUE-ARM

MAXIMUM Concentric Reducer

TIGEAR-2

FEATURES/BENEFITS PAGE G2-3	NOMENCLATURE PAGE G2-11	SELECTION/DIMENSIONS PAGE G2-144	RELATED PRODUCTS PAGE G2-152
--------------------------------	----------------------------	-------------------------------------	---------------------------------

EASY SELECTIONS



HYDROIL TORQUE-ARM Shaft Mount Speed Reducers

TABLE 13 - CLASS II SELECTION TABLE HXT REDUCERS - DOUBLE REDUCTION

HXT-515B - HXT-725

Reducer Size	Requirements ★	Output Speed										
		10	15	20	25	30	35	40	45	50	55	60
HXT-515B	OUTPUT HP(RUN)	3.3	4.7	6.1	7.5	8.9	10.3	11.7	12.8	13.8	14.9	15.9
	Running Torque	20537	19624	19168	18894	18711	18581	18483	17890	17415	17027	16703
	Starting Torque	31924	31924	31924	31924	31924	31924	31924	31924	31924	31924	31924
	Running Pressure	1518	1450	1417	1396	1383	1373	1366	1322	1287	1258	1235
	Flow Rate, GPM	8.4	10.3	12.4	14.5	16.6	18.7	20.9	22.9	25.0	27.1	29.1
HXT-525B	OUTPUT HP(RUN)	3.3	4.7	6.1	7.5	8.9	10.3	11.7	12.8	13.8	14.9	15.9
	Running Torque	20537	19624	19168	18894	18711	18581	18483	17890	17415	17027	16703
	Starting Torque	29528	29528	29528	29528	29528	29528	29528	29528	29528	29528	29528
	Running Pressure	1641	1568	1532	1510	1495	1485	1477	1430	1392	1361	1335
	Flow Rate, GPM	6.4	8.3	10.3	12.2	14.2	16.2	18.2	20.1	22.0	24.0	25.9
HXT-615	OUTPUT HP(RUN)	5.1	7.5	9.8	12.1	14.4	16.7	19.0	20.8	22.5	24.3	26.1
	Running Torque	32448	31307	30737	30394	30166	30003	29881	29071	28423	27893	27451
	Starting Torque	31779	31779	31779	31779	31779	31779	31779	31779	31779	31779	31779
	Running Pressure	2409	2325	2282	2257	2240	2228	2219	2158	2110	2071	2038
	Flow Rate, GPM	10.7	12.6	14.7	16.7	18.8	21.0	23.1	25.1	27.1	29.1	31.2
HXT-625	OUTPUT HP(RUN)	5.1	7.5	9.8	12.1	14.4	16.7	19.0	20.8	22.5	24.3	26.1
	Running Torque	32448	31307	30737	30394	30166	30003	29881	29071	28423	27893	27451
	Starting Torque	52094	52094	52094	52094	52094	52094	52094	52094	52094	52094	52094
	Running Pressure	1470	1418	1392	1377	1366	1359	1353	1317	1287	1263	1243
	Flow Rate, GPM	11.0	14.3	17.8	21.3	24.7	28.2	31.7	35.1	38.6	42.0	45.5
HXT-715	OUTPUT HP(RUN)	7.2	10.5	13.7	17.0	20.2	23.5	26.7	29.5	32.4	35.2	38.0
	Running Torque	45591	44040	43264	42798	42488	42266	42100	41384	40811	40342	39951
	Starting Torque	57132	57132	57132	57132	57132	57132	57132	57132	57132	57132	57132
	Running Pressure	1883	1819	1787	1768	1755	1746	1739	1709	1685	1666	1650
	Flow Rate, GPM	11.5	15.2	19.0	22.8	26.6	30.5	34.3	38.1	41.9	45.7	49.5
HXT-725	OUTPUT HP(RUN)	7.2	10.5	13.7	17.0	20.2	23.5	26.7	29.5	32.4	35.2	38.0
	Running Torque	45591	44040	43264	42798	42488	42266	42100	41384	40811	40342	39951
	Starting Torque	50975	50975	50975	50975	50975	50975	50975	50975	50975	50975	50975
	Running Pressure	2110	2039	2003	1981	1967	1956	1949	1916	1889	1867	1849
	Flow Rate, GPM	12.5	15.8	19.1	22.5	25.9	29.3	32.7	36.1	39.4	42.8	46.2

★ See page G2-143 for definition of requirements.

FEATURES/BENEFITS PAGE G2-3	NOMENCLATURE PAGE G2-11	SELECTION/DIMENSIONS PAGE G2-144	RELATED PRODUCTS PAGE G2-152
--------------------------------	----------------------------	-------------------------------------	---------------------------------



HYDROIL TORQUE-ARM Shaft Mount Speed Reducers

TABLE 13 - CLASS II SELECTION TABLE HXT REDUCERS - DOUBLE REDUCTION

HXT-515B - HXT-725 (CONT'D)

Reducer Size	Output Speed															
	65	70	75	80	85	90	95	100	105	110	115	120	125	130	135	140
HXT-515B	16.9	18.0	19.0	20.1	21.1	22.2	21.7	21.1	20.5	19.8	19.2	18.6	18.0			
	16429	16195	15991	15813	15656	15517	14396	13298	12305	11344	10522	9769	9076			
	31924	31924	31924	31924	31924	31924	31924	31924	31924	31924	31924	31924	31924			
	1214	1197	1182	1169	1157	1147	1064	983	909	838	778	722	671			
	31.2	33.3	35.5	37.6	39.7	41.8	43.8	45.7	47.7	49.6	51.6	53.6	55.6			
HXT-525B	16.9	18.0	19.0	20.1												
	16429	16195	15991	15813												
	29528	29528	29528	29528												
	1313	1294	1278	1264												
	27.9	29.8	31.8	33.8												
HXT-615	27.9	29.7	31.5	33.3	35.1	33.7	31.8	29.8	27.8	25.9	23.9	22.0	20.0			
	27077	26756	26479	26236	26021	23599	21097	18781	16687	14840	13098	11555	10084			
	31779	31779	31779	31779	31779	31779	31779	31779	31779	31779	31779	31779	31779			
	2010	1987	1966	1948	1932	1752	1566	1395	1239	1102	973	858	749			
	33.2	35.3	37.4	39.5	41.6	43.3	44.9	46.6	48.3	50.1	51.9	53.7	55.6			
HXT-625	27.9	29.7	31.5	33.3												
	27077	26756	26479	26236												
	52094	52094	52094	52094												
	1226	1212	1199	1188												
	49.0	52.4	55.9	59.4												
HXT-715	40.9	43.7	46.5	49.3	49.3	47.2	45.0	43.0	41.0	39.0	37.0	35.0				
	39620	39337	39091	38876	36555	33053	29854	27101	24610	22345	20278	18382				
	57132	57132	57132	57132	57132	57132	57132	57132	57132	57132	57132	57132				
	1636	1625	1614	1606	1510	1365	1233	1119	1016	923	837	759				
	53.4	57.2	61.0	64.9	68.5	72.1	75.7	79.3	83.0	86.6	90.3	94.0				
HXT-725	40.9	43.7	46.5													
	39620	39337	39091													
	50975	50975	50975													
	1834	1821	1809													
	49.6	53.0	56.4													

Gearing Reference Guide

TORQUE-ARM II

TORQUE-ARM

MAXIMUM Concentric Reducer

TIGEAR-2

EASY SELECTIONS



HYDROIL TORQUE-ARM Shaft Mount Speed Reducers

TABLE 14 - CLASS III SELECTION TABLE HXT REDUCERS - DOUBLE REDUCTION

HXT-115 - HXT-425A

Reducer Size	Requirements ★	Output Speed										
		10	15	20	25	30	35	40	45	50	55	60
HXT-115	OUTPUT HP(RUN)	0.3	0.4	0.6	0.7	0.8	1.0	1.1	1.2	1.3	1.4	1.6
	Running Torque	2013	1888	1826	1788	1763	1746	1732	1698	1671	1649	1630
	Starting Torque	4025	4025	4025	4025	4025	4025	4025	4025	4025	4025	4025
	Running Pressure	843	791	764	749	738	731	725	711	700	690	683
	Flow Rate, GPM	1.4	1.7	2.1	2.5	2.8	3.2	3.6	4.0	4.3	4.7	5.1
HXT-125	OUTPUT HP(RUN)	0.3	0.4	0.6	0.7	0.8	1.0	1.1	1.2	1.3	1.4	1.6
	Running Torque	2013	1888	1826	1788	1763	1746	1732	1698	1671	1649	1630
	Starting Torque	2868	2868	2868	2868	2868	2868	2868	2868	2868	2868	2868
	Running Pressure	1183	1110	1073	1051	1036	1026	1018	998	982	969	958
	Flow Rate, GPM	1.1	1.4	1.6	1.9	2.1	2.4	2.7	2.9	3.2	3.5	3.7
HXT-215	OUTPUT HP(RUN)	0.6	0.8	1.0	1.3	1.5	1.8	2.0	2.2	2.4	2.6	2.8
	Running Torque	3623	3412	3306	3243	3201	3171	3148	3085	3035	2994	2959
	Starting Torque	3697	3697	3697	3697	3697	3697	3697	3697	3697	3697	3697
	Running Pressure	1651	1555	1507	1478	1459	1445	1435	1406	1383	1365	1349
	Flow Rate, GPM	2.0	2.2	2.5	2.9	3.2	3.5	3.9	4.2	4.5	4.9	5.2
HXT-225	OUTPUT HP(RUN)	0.6	0.8	1.0	1.3	1.5	1.8	2.0	2.2	2.4	2.6	2.8
	Running Torque	3623	3412	3306	3243	3201	3171	3148	3085	3035	2994	2959
	Starting Torque	6152	6152	6152	6152	6152	6152	6152	6152	6152	6152	6152
	Running Pressure	993	935	906	889	877	869	863	845	832	820	811
	Flow Rate, GPM	1.9	2.5	3.0	3.6	4.2	4.7	5.3	5.9	6.4	7.0	7.6
HXT-315A	OUTPUT HP(RUN)	0.9	1.3	1.7	2.1	2.5	3.0	3.4	3.7	4.0	4.4	4.7
	Running Torque	5549	5447	5396	5365	5345	5330	5319	5189	5086	5001	4930
	Starting Torque	17190	17190	17190	17190	17190	17190	17190	17190	17190	17190	17190
	Running Pressure	762	748	741	736	734	732	730	712	698	686	677
	Flow Rate, GPM	3.5	4.6	5.8	6.9	8.1	9.2	10.4	11.5	12.6	13.8	14.9
HXT-325A	OUTPUT HP(RUN)	0.9	1.3	1.7	2.1	2.5	3.0	3.4	3.7	4.0	4.4	4.7
	Running Torque	5549	5447	5396	5365	5345	5330	5319	5189	5086	5001	4930
	Starting Torque	6479	6479	6479	6479	6479	6479	6479	6479	6479	6479	6479
	Running Pressure	1443	1417	1403	1396	1390	1386	1384	1350	1323	1301	1282
	Flow Rate, GPM	2.3	2.9	3.5	4.1	4.7	5.3	6.0	6.5	7.1	7.7	8.3
HXT-415A	OUTPUT HP(RUN)	1.3	1.9	2.5	3.1	3.8	4.4	5.0	5.5	6.0	6.6	7.1
	Running Torque	8338	8114	8002	7935	7891	7859	7835	7712	7613	7533	7466
	Starting Torque	17479	17479	17479	17479	17479	17479	17479	17479	17479	17479	17479
	Running Pressure	1126	1095	1080	1071	1065	1061	1058	1041	1028	1017	1008
	Flow Rate, GPM	4.1	5.2	6.3	7.5	8.7	9.8	11.0	12.2	13.3	14.5	15.7
HXT-425A	OUTPUT HP(RUN)	1.3	1.9	2.5	3.1	3.8	4.4	5.0	5.5	6.0	6.6	7.1
	Running Torque	8338	8114	8002	7935	7891	7859	7835	7712	7613	7533	7466
	Starting Torque	28164	28164	28164	28164	28164	28164	28164	28164	28164	28164	28164
	Running Pressure	699	680	670	665	661	658	656	646	638	631	625
	Flow Rate, GPM	4.9	6.7	8.6	10.5	12.4	14.3	16.2	18.1	20.0	21.8	23.7

★ See page G2-143 for definition of requirements.

FEATURES/BENEFITS PAGE G2-3	NOMENCLATURE PAGE G2-11	SELECTION/DIMENSIONS PAGE G2-144	RELATED PRODUCTS PAGE G2-152
--------------------------------	----------------------------	-------------------------------------	---------------------------------



HYDROIL TORQUE-ARM Shaft Mount Speed Reducers

TABLE 14 - CLASS III SELECTION TABLE HXT REDUCERS - DOUBLE REDUCTION

HXT-115 - HXT-425A

Reducer Size	Output Speed															
	65	70	75	80	85	90	95	100	105	110	115	120	125	130	135	140
HXT-115	1.7	1.8	1.9	2.0	2.1	2.2	2.3	2.4	2.5	2.7	2.8	2.9	3.0	3.1	3.2	3.3
	1615	1601	1589	1579	1570	1562	1550	1538	1528	1519	1510	1502	1492	1482	1473	1464
	4025	4025	4025	4025	4025	4025	4025	4025	4025	4025	4025	4025	4025	4025	4025	4025
	676	670	666	661	657	654	649	644	640	636	632	629	625	620	617	613
	5.5	5.8	6.2	6.6	7.0	7.3	7.7	8.1	8.5	8.9	9.2	9.6	10.0	10.4	10.7	11.1
HXT-125	1.7	1.8	1.9	2.0	2.1											
	1615	1601	1589	1579	1570											
	2868	2868	2868	2868	2868											
	949	941	934	928	923											
	4.0	4.3	4.5	4.8	5.1											
HXT-215	3.0	3.2	3.4	3.6	3.8	4.0	4.2	4.4	4.6	4.8	5.0	5.2	5.3	5.5	5.7	5.9
	2930	2906	2884	2865	2848	2834	2807	2783	2762	2742	2724	2707	2693	2679	2667	2655
	3697	3697	3697	3697	3697	3697	3697	3697	3697	3697	3697	3697	3697	3697	3697	3697
	1336	1324	1315	1306	1298	1292	1280	1269	1259	1250	1242	1234	1228	1221	1216	1210
	5.6	5.9	6.2	6.6	6.9	7.3	7.6	8.0	8.3	8.6	9.0	9.3	9.7	10.0	10.4	10.7
HXT-225	3.0	3.2	3.4	3.6	3.8											
	2930	2906	2884	2865	2848											
	6152	6152	6152	6152	6152											
	803	796	790	785	780											
	8.2	8.7	9.3	9.9	10.5											
HXT-315A	5.0	5.4	5.7	6.0	6.3	6.7	6.9	7.2	7.4	7.6	7.9	8.1	8.4	8.6	8.8	9.1
	4870	4819	4774	4735	4701	4671	4586	4510	4441	4379	4322	4270	4216	4166	4119	4077
	17190	17190	17190	17190	17190	17190	17190	17190	17190	17190	17190	17078	16862	16663	16478	16306
	668	661	655	650	645	641	630	619	610	601	593	586	579	572	565	560
	16.1	17.2	18.4	19.5	20.7	21.8	23.0	24.1	25.3	26.4	27.6	28.7	29.9	31.0	32.2	33.3
HXT-325A	5.0	5.4	5.7	6.0	6.3											
	4870	4819	4774	4735	4701											
	6479	6479	6479	6479	6479											
	1267	1253	1242	1232	1223											
	8.9	9.5	10.1	10.7	11.3											
HXT-415A	7.6	8.2	8.7	9.2	9.8	10.3	10.8	11.2	11.7	12.2	12.6	13.1	13.5	13.8	14.2	14.6
	7409	7360	7318	7281	7249	7220	7147	7082	7024	6970	6921	6876	6785	6701	6623	6551
	17479	17479	17479	17479	17479	17479	17479	17479	17479	17479	17479	17479	17479	17479	17479	17479
	1000	994	988	983	979	975	965	956	948	941	934	928	916	905	894	884
	16.8	18.0	19.2	20.3	21.5	22.7	23.9	25.0	26.2	27.4	28.5	29.7	30.9	32.0	33.2	34.3
HXT-425A	7.6	8.2	8.7	9.2	9.8											
	7409	7360	7318	7281	7249											
	28164	28164	28164	28164	28164											
	621	617	613	610	607											
	25.6	27.5	29.4	31.3	33.2											

FEATURES/BENEFITS PAGE G2-3	NOMENCLATURE PAGE G2-11	SELECTION/DIMENSIONS PAGE G2-144	RELATED PRODUCTS PAGE G2-152
--------------------------------	----------------------------	-------------------------------------	---------------------------------

EASY SELECTIONS



HYDROIL TORQUE-ARM Shaft Mount Speed Reducers

TABLE 14 - CLASS III SELECTION TABLE HXT REDUCERS - DOUBLE REDUCTION

HXT-515B - HXT-725

Reducer Size	Requirements ★	Output Speed										
		10	15	20	25	30	35	40	45	50	55	60
HXT-515B	OUTPUT HP(RUN)	2.3	3.3	4.3	5.2	6.2	7.2	8.2	8.9	9.7	10.4	11.1
	Running Torque	14376	13737	13417	13226	13098	13007	12938	12523	12191	11919	11692
	Starting Torque	31924	31924	31924	31924	31924	31924	31924	31924	31924	31924	31924
	Running Pressure	1063	1015	992	978	968	961	956	926	901	881	864
	Flow Rate, GPM	7.1	9.2	11.3	13.4	15.5	17.6	19.8	21.9	23.9	26.0	28.2
HXT-525B	OUTPUT HP(RUN)	2.3	3.3	4.3	5.2	6.2	7.2	8.2	8.9	9.7	10.4	11.1
	Running Torque	14376	13737	13417	13226	13098	13007	12938	12523	12191	11919	11692
	Starting Torque	29528	29528	29528	29528	29528	29528	29528	29528	29528	29528	29528
	Running Pressure	1149	1098	1072	1057	1047	1039	1034	1001	974	952	934
	Flow Rate, GPM	5.7	7.6	9.6	11.5	13.5	15.5	17.5	19.4	21.4	23.3	25.3
HXT-615	OUTPUT HP(RUN)	3.6	5.2	6.8	8.4	10.1	11.7	13.3	14.5	15.8	17.0	18.3
	Running Torque	22714	21915	21516	21276	21116	21002	20917	20350	19896	19525	19216
	Starting Torque	31779	31779	31779	31779	31779	31779	31779	31779	31779	31779	31779
	Running Pressure	1686	1627	1598	1580	1568	1559	1553	1511	1477	1450	1427
	Flow Rate, GPM	8.8	10.8	12.8	14.9	17.1	19.2	21.3	23.3	25.4	27.5	29.5
HXT-625	OUTPUT HP(RUN)	3.6	5.2	6.8	8.4	10.1	11.7	13.3	14.5	15.8	17.0	18.3
	Running Torque	22714	21915	21516	21276	21116	21002	20917	20350	19896	19525	19216
	Starting Torque	52094	52094	52094	52094	52094	52094	52094	52094	52094	52094	52094
	Running Pressure	1029	993	975	964	956	951	947	922	901	884	870
	Flow Rate, GPM	9.8	13.2	16.7	20.1	23.6	27.1	30.6	34.1	37.5	41.0	44.5
HXT-715	OUTPUT HP(RUN)	5.1	7.3	9.6	11.9	14.2	16.4	18.7	20.7	22.7	24.6	26.6
	Running Torque	31914	30828	30285	29959	29742	29587	29470	28969	28567	28239	27966
	Starting Torque	57132	57132	57132	57132	57132	57132	57132	57132	57132	57132	57132
	Running Pressure	1318	1273	1251	1237	1228	1222	1217	1196	1180	1166	1155
	Flow Rate, GPM	10.3	14.1	17.9	21.7	25.6	29.4	33.3	37.1	40.9	44.7	48.6
HXT-725	OUTPUT HP(RUN)	5.1	7.3	9.6	11.9	14.2	16.4	18.7	20.7	22.7	24.6	26.6
	Running Torque	31914	30828	30285	29959	29742	29587	29470	28969	28567	28239	27966
	Starting Torque	50975	50975	50975	50975	50975	50975	50975	50975	50975	50975	50975
	Running Pressure	1477	1427	1402	1387	1377	1370	1364	1341	1322	1307	1294
	Flow Rate, GPM	10.8	14.1	17.5	20.9	24.3	27.7	31.2	34.5	37.9	41.3	44.7

★ See page G2-143 for definition of requirements.

FEATURES/BENEFITS PAGE G2-3	NOMENCLATURE PAGE G2-11	SELECTION/DIMENSIONS PAGE G2-144	RELATED PRODUCTS PAGE G2-152
--------------------------------	----------------------------	-------------------------------------	---------------------------------



HYDROIL TORQUE-ARM Shaft Mount Speed Reducers

TABLE 14 - CLASS III SELECTION TABLE HXT REDUCERS - DOUBLE REDUCTION

HXT-515B - HXT-725

Reducer Size	Output Speed															
	65	70	75	80	85	90	95	100	105	110	115	120	125	130	135	140
HXT-515B	11.9	12.6	13.3	14.1	14.8	15.5	16.1	16.6	17.2	17.7	18.2	18.6	18.0			
	11501	11336	11194	11069	10959	10862	10653	10466	10296	10141	10000	9769	9076			
	31924	31924	31924	31924	31924	31924	31924	31924	31924	31924	31924	31924	31924			
	850	838	827	818	810	803	787	774	761	750	739	722	671			
	30.3	32.4	34.5	36.6	38.8	40.9	43.0	45.1	47.3	49.4	51.5	53.6	55.6			
HXT-525B	11.9	12.6	13.3	14.1												
	11501	11336	11194	11069												
	29528	29528	29528	29528												
	919	906	895	885												
	27.3	29.2	31.2	33.2												
HXT-615	19.5	20.8	22.1	23.3	24.6	25.8	26.6	27.5	27.8	25.9	23.9	22.0	20.0			
	18954	18729	18535	18365	18215	18081	17680	17318	16687	14840	13098	11555	10084			
	31779	31779	31779	31779	31779	31779	31779	31779	31779	31779	31779	31779	31779			
	1407	1391	1376	1364	1352	1343	1313	1286	1239	1102	973	858	749			
	31.6	33.7	35.8	37.9	40.1	42.2	44.2	46.3	48.3	50.1	51.9	53.7	55.6			
HXT-625	19.5	20.8	22.1	23.3												
	18954	18729	18535	18365												
	52094	52094	52094	52094												
	858	848	840	832												
	48.0	51.5	55.0	58.4												
HXT-715	28.6	30.6	32.6	34.5	36.5	38.5	40.2	41.9	41.0	39.0	37.0	35.0				
	27734	27536	27364	27213	27080	26962	26663	26394	24610	22345	20278	18382				
	57132	57132	57132	57132	57132	57132	57132	57132	57132	57132	57132	57132				
	1145	1137	1130	1124	1118	1114	1101	1090	1016	923	837	759				
	52.4	56.2	60.1	63.9	67.8	71.6	75.4	79.3	83.0	86.6	90.3	94.0				
HXT-725	28.6	30.6	32.6													
	27734	27536	27364													
	50975	50975	50975													
	1284	1275	1267													
	48.1	51.5	55.0													

Gearing Reference Guide

TORQUE-ARM II

TORQUE-ARM

MAXIMUM Concentric Reducer

TIGEAR-2

EASY SELECTIONS



HYDROIL TORQUE-ARM Shaft Mount Speed Reducers

TABLE 15 - CLASS I SELECTION TABLE HXT REDUCERS - SINGLE REDUCTION

Reducer Size	Requirements ★	Output Speed															
		90	100	110	120	130	140	150	160	180	200	220	250	300	350	400	
HXT-105	OUTPUT HP(RUNNING)	3.9	4.2	4.4	4.7	5.0	5.2	5.5	5.7	6.2	6.7	6.9	7.1	7.6	7.9	8.3	
	Running Torque	2758	2641	2546	2467	2400	2342	2293	2249	2176	2118	1973	1799	1586	1424	1303	
	Starting Torque	5515	5283	5093	4934	4800	4685	4585	4498	4353	4237	3946	3598	3172	2848	2605	
	Running Pressure	982	940	907	878	854	834	816	801	775	754	702	640	565	507	464	
	Flow Rate, GPM	9.4	10.2	11.0	11.8	12.7	13.5	14.4	15.2	16.9	18.7	20.3	22.9	27.1	31.4	35.7	
HXT-205	OUTPUT HP(RUNNING)	6.8	7.1	7.4	7.7	8.0	8.3	8.6	8.9	9.5	10.1	10.5	11.1	12.0	12.9	13.8	
	Running Torque	4759	4475	4243	4049	3886	3745	3624	3517	3340	3198	3014	2793	2523	2322	2171	
	Starting Torque	6238	6238	6238	6238	6238	6238	6238	6238	6238	6238	6028	5586	5046	4644	4342	
	Running Pressure	1800	1693	1605	1532	1470	1417	1371	1330	1263	1210	1140	1056	954	878	821	
	Flow Rate, GPM	10.1	10.8	11.5	12.2	12.9	13.7	14.4	15.2	16.7	18.3	19.9	22.2	26.2	30.2	34.2	
HXT-305A	OUTPUT HP(RUNNING)	10.1	10.7	11.3	12.0	12.6	13.2	13.8	14.4	15.7	16.9	17.6	17.7	16.8	15.9	15.0	
	Running Torque	7074	6758	6499	6284	6102	5946	5810	5692	5495	5337	5056	4462	3529	2863	2363	
	Starting Torque	11851	11851	11851	11851	11851	11851	11621	11384	10989	10673	10112	9438	8614	7705	7024	
	Running Pressure	1408	1346	1294	1251	1215	1184	1157	1133	1094	1063	1007	888	703	570	471	
	Flow Rate, GPM	17.9	19.3	20.7	22.1	23.6	25.1	26.6	28.1	31.1	34.2	37.1	41.5	48.9	56.3	63.9	
HXT-405A	OUTPUT HP(RUNNING)	17.7	18.5	19.3	20.1	20.9	21.7	22.5	23.3	24.5	23.8	23.1	22.1	20.4	18.7	17.0	
	Running Torque	12387	11655	11056	10557	10135	9773	9459	9185	8578	7500	6618	5571	4286	3367	2679	
	Starting Torque	11956	11956	11956	11956	11956	11956	11956	11956	11956	11956	11956	11956	11956	11956	11956	
	Running Pressure	2445	2300	2182	2083	2000	1929	1867	1813	1693	1480	1306	1099	846	665	529	
	Flow Rate, GPM	20.8	21.9	23.2	24.5	25.9	27.3	28.7	30.1	33.0	35.6	38.3	42.4	49.7	57.1	64.6	
HXT-505A	OUTPUT HP(RUNNING)	21.9	23.1	24.3	25.5	26.7	27.9	29.1	30.4	31.3	30.1	28.9	27.1	24.1	21.0	18.0	
	Running Torque	15321	14552	13923	13398	12954	12574	12244	11955	10959	9485	8279	6832	5063	3782	2836	
	Starting Torque	21713	21713	21713	21713	21713	21713	21713	21713	21713	21713	21529	20748	19794	18659	17808	
	Running Pressure	1665	1581	1513	1456	1408	1366	1331	1299	1191	1031	900	742	550	411	308	
	Flow Rate, GPM	29.2	31.9	34.6	37.3	40.1	42.9	45.7	48.5	54.0	59.5	64.9	73.2	87.20	101.3	115.4	

★ See page G2-143 for definition of requirements.



HYDROIL TORQUE-ARM Shaft Mount Speed Reducers

TABLE 16 - CLASS II SELECTION TABLE - HXT REDUCERS - SINGE REDUCTION

Reducer Size	Requirements ★	Output Speed														
		90	100	110	120	130	140	150	160	180	200	220	250	300	350	400
HXT-105	OUTPUT HP(RUNNING)	2.8	3.0	3.2	3.4	3.5	3.7	3.9	4.1	4.4	4.8	4.9	5.1	5.4	5.6	5.9
	Running Torque	1970	1887	1819	1762	1714	1673	1638	1606	1555	1513	1409	1285	1133	1017	930
	Starting Torque	5515	5283	5093	4934	4800	4685	4585	4498	4353	4237	3946	3598	3172	2848	2605
	Running Pressure	701	672	648	627	610	596	583	572	553	539	502	457	403	362	331
	Flow Rate, GPM	8.9	9.8	10.6	11.5	12.3	13.2	14.0	14.9	16.6	18.3	20.0	22.6	26.9	31.2	35.5
HXT-205	OUTPUT HP(RUNNING)	4.9	5.1	5.3	5.5	5.7	5.9	6.2	6.4	6.8	7.2	7.5	7.9	8.6	9.2	9.8
	Running Torque	3399	3197	3031	2892	2775	2675	2588	2512	2386	2284	2153	1995	1802	1659	1551
	Starting Torque	6238	6238	6238	6238	6238	6238	6238	6238	6238	6238	6028	5586	5046	4644	4342
	Running Pressure	1286	1209	1146	1094	1050	1012	979	950	902	864	814	755	682	627	587
	Flow Rate, GPM	9.4	10.1	10.8	11.5	12.3	13.1	13.8	14.6	16.2	17.8	19.4	21.7	25.8	29.8	33.9
HXT-305A	OUTPUT HP(RUNNING)	7.2	7.7	8.1	8.5	9.0	9.4	9.9	10.3	11.2	12.1	12.6	13.4	14.6	15.3	15.0
	Running Torque	5053	4827	4642	4489	4358	4247	4150	4066	3925	3812	3611	3371	3076	2752	2363
	Starting Torque	11851	11851	11851	11851	11851	11851	11621	11384	10989	10673	10112	9438	8614	7705	7024
	Running Pressure	1006	961	924	894	868	846	826	810	781	759	719	671	613	548	471
	Flow Rate, GPM	16.8	18.2	19.7	21.2	22.7	24.2	25.7	27.2	30.3	33.4	36.4	40.9	48.6	56.3	63.9
HXT-405A	OUTPUT HP(RUNNING)	12.6	13.2	13.8	14.4	14.9	15.5	16.1	16.7	17.8	19.0	20.2	22.0	20.4	18.7	17.0
	Running Torque	8848	8325	7897	7541	7239	6981	6757	6561	6234	5973	5776	5541	4286	3367	2679
	Starting Torque	11956	11956	11956	11956	11956	11956	11956	11956	11956	11956	11956	11956	11956	11956	11956
	Running Pressure	1746	1643	1559	1488	1429	1378	1333	1295	1230	1179	1140	1093	846	665	529
	Flow Rate, GPM	18.9	20.2	21.5	22.9	24.4	25.8	27.3	28.7	31.7	34.8	37.8	42.4	49.7	57.1	64.6
HXT-505A	OUTPUT HP(RUNNING)	15.6	16.5	17.4	18.2	19.1	20.0	20.8	21.7	23.4	25.1	26.8	27.1	24.1	21.0	18.0
	Running Torque	10944	10394	9945	9570	9253	8981	8746	8540	8196	7921	7689	6832	5063	3782	2836
	Starting Torque	21713	21713	21713	21713	21713	21713	21713	21713	21713	21713	21529	20748	19794	18659	17808
	Running Pressure	1189	1130	1081	1040	1006	976	950	928	891	861	836	742	550	411	308
	Flow Rate, GPM	28.2	31.0	33.7	36.5	39.3	42.1	44.9	47.8	53.4	59.1	64.8	73.2	87.2	101.3	115.4

★ See page G2-143 for definition of requirements.

Gearing Reference Guide

TORQUE-ARM II

TORQUE-ARM

MAXIMUM Concentric Reducer

TIGEAR-2

FEATURES/BENEFITS PAGE G2-3	NOMENCLATURE PAGE G2-11	SELECTION/DIMENSIONS PAGE G2-144	RELATED PRODUCTS PAGE G2-152
--------------------------------	----------------------------	-------------------------------------	---------------------------------

EASY SELECTIONS



HYDROIL TORQUE-ARM Shaft Mount Speed Reducers

TABLE 17 - CLASS III SELECTION TABLE HXT REDUCERS - SINGLE REDUCTION

Reducer Size	Requirements ★	Output Speed														
		90	100	110	120	130	140	150	160	180	200	220	250	300	350	400
HXT-105	OUTPUT HP(RUNNING)	2.0	2.1	2.2	2.3	2.5	2.6	2.7	2.9	3.1	3.4	3.4	3.6	3.8	4.0	4.1
	Running Torque	1379	1321	1273	1234	1200	1171	1146	1125	1088	1059	987	899	793	712	651
	Starting Torque	5515	5283	5093	4934	4800	4685	4585	4498	4353	4237	3946	3598	3172	2848	2605
	Running Pressure	491	470	453	439	427	417	408	400	387	377	351	320	282	254	232
	Flow Rate, GPM	8.6	9.5	10.3	11.2	12.0	12.9	13.8	14.6	16.4	18.1	19.8	22.4	26.7	31.0	35.4
HXT-205	OUTPUT HP(RUNNING)	3.4	3.6	3.7	3.9	4.0	4.2	4.3	4.5	4.8	5.1	5.3	5.5	6.0	6.4	6.9
	Running Torque	2380	2238	2121	2025	1943	1873	1812	1759	1670	1599	1507	1397	1262	1161	1086
	Starting Torque	6238	6238	6238	6238	6238	6238	6238	6238	6238	6238	6028	5586	5046	4644	4342
	Running Pressure	900	846	802	766	735	708	685	665	632	605	570	528	477	439	411
	Flow Rate, GPM	8.8	9.5	10.3	11.0	11.8	12.6	13.4	14.2	15.8	17.4	19.0	21.4	25.5	29.5	33.6
HXT-305A	OUTPUT HP(RUNNING)	5.1	5.4	5.7	6.0	6.3	6.6	6.9	7.2	7.8	8.5	8.8	9.4	10.3	10.7	11.1
	Running Torque	3537	3379	3250	3142	3051	2973	2905	2846	2747	2668	2528	2359	2153	1926	1756
	Starting Torque	11851	11851	11851	11851	11851	11851	11621	11384	10989	10673	10112	9438	8614	7705	7024
	Running Pressure	704	673	647	626	607	592	578	567	547	531	503	470	429	384	350
	Flow Rate, GPM	16.0	17.5	19.0	20.5	22.0	23.5	25.0	26.6	29.7	32.7	35.8	40.4	48.1	55.8	63.6
HXT-405A	OUTPUT HP(RUNNING)	8.8	9.2	9.6	10.1	10.5	10.9	11.3	11.7	12.5	13.3	14.1	15.4	17.5	18.7	17.0
	Running Torque	6194	5828	5528	5279	5068	4887	4730	4592	4364	4181	4043	3879	3677	3367	2679
	Starting Torque	11956	11956	11956	11956	11956	11956	11956	11956	11956	11956	11956	11956	11956	11956	11956
	Running Pressure	1222	1150	1091	1042	1000	964	933	906	861	825	798	765	726	665	529
	Flow Rate, GPM	17.5	18.9	20.3	21.7	23.2	24.7	26.2	27.7	30.7	33.8	36.9	41.5	49.3	57.1	64.6
HXT-505A	OUTPUT HP(RUNNING)	10.9	11.5	12.1	12.8	13.4	14.0	14.6	15.2	16.4	17.6	18.8	20.6	23.6	21.0	18.0
	Running Torque	7661	7276	6961	6699	6477	6287	6122	5978	5737	5545	5382	5187	4948	3782	2836
	Starting Torque	21713	21713	21713	21713	21713	21713	21713	21713	21713	21713	21529	20748	19794	18659	17808
	Running Pressure	832	791	756	728	704	683	665	650	623	603	585	564	538	411	308
	Flow Rate, GPM	27.5	30.3	33.1	35.9	38.7	41.5	44.4	47.2	52.9	58.6	64.3	72.9	87.2	101.3	115.4

★ See page G2-143 for definition of requirements.



HYDROIL TORQUE-ARM Shaft Mount Speed Reducers

★ **Requirements:**

Output HP-Horsepower rating of the reducer/motor under continuous operation after load has been started.

Running Torque-Continuous output torque rating of reducer/motor (in.-lbs.)

Starting Torque-Momentary output torque available for starting (in.-lbs.)

Running Pressure-Motor pressure required to generate running torque. This will start loads not to exceed 75% of the running load. For greater starting requirements, motor pressure may be increased-see table 18. (PSI)

Flow Rate-Flow required for given output RPM. With oil viscosity of 300SUS @ 100°F. for A10 and A20 motors, and 200SUS @ 100°F. for B30, B40 and B50 motors.

Table 18 - Maximum Hydraulic Motor Pressures Available for Starting

Double Reduction	Single Reduction	Maximum Hydraulic Pressure
---	HXT105	2500 psi
---	HXT205	
HXT315A	HXT305A	
HXT415A, 425A	HXT405A	
HXT515B, 525B	HXT505A	
HXT615, 625	---	
HXT715, 725	---	2000 psi
HXT115, 125	---	
HXT215, 225	---	
HXT325A	---	

SELECTION/DIMENSIONS



HYDROIL TORQUE-ARM Shaft Mount Speed Reducers HXT1 THRU HXT7 TAPER BUSHED REDUCERS

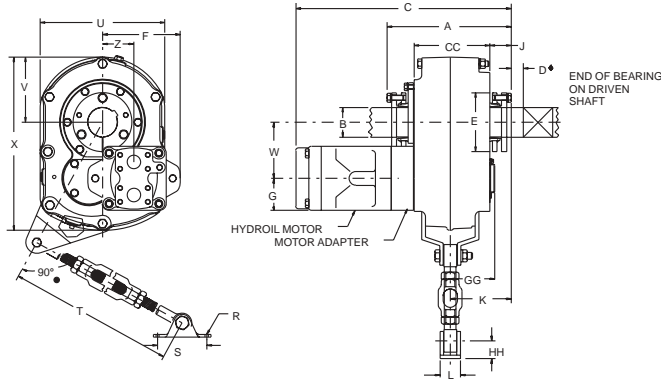

- ◆ Recommended minimum distance to loosen bushing using bushing screws as jack screws.
Reducer will operate satisfactorily at 90° or 180° from normal position shown in front view by relocating breather and drain plugs.

- The ideal position for the TORQUE-ARM is at right angles to a line between the point of attachment of the TORQUE-ARM to the reducer and the output shaft. This may vary up to 30° either way. **CAUTION:** Exceeding the ± 30° variance of the TORQUE-ARM could result in excessive reaction load and result in damage to the equipment.

HXT1 THRU HXT7 HYDROIL DOUBLE REDUCTION TAPER BUSHED TORQUE-ARM SPEED REDUCERS

Reducer Size		AGMA Code		Gear Ratio		Part Number		Wt.	HYDROIL Motor		A	B Max. Bore	C	D	E	F	G	J	K
15:1	25:1	15:1	25:1	15:1	25:1	15:1	25:1		Size	Wt.									
.....	HXT125	107H25	25.64	241070	49	A10	11	7.06	1.44	13.22	1.25	3.25	4.47	2.41	1.28	3.53
HXT115	107H15	15.35	241069♣												
HXT215	HXT225	115H15	115H25	14.10	23.46	242086	242087♣	65	A20	11	7.31	1.94	13.38	1.25	4.06	4.69	2.41	1.38	3.66
.....	HXT325A	205H25	24.71	243508	112	A20	11	9.22	2.19	14.64	1.50	4.38	4.88	2.41	1.58	4.44
HXT315A	203H15	14.88	243507												
HXT415A	HXT425A	207H15	207H25	15.13	24.38	244532	244533	143	B30	30	10	2.44	16.13	1.75	4.81	6.19	2.38	1.81	4.75
.....	HXT525B	215H25	25.56	245558	212	B30	30	10.5	2.94	16.88	1.81	5.63	6.50	2.38	1.94	5.50
HXT515B	215H15	15.40	245557												
HXT615	HXT625	307H15	307H25	15.33	25.13	246154	246155	293	B40	55	11.5	3.44	18.58	1.81	6.13	8.28	3.06	1.94	5.70
.....	HXT725	315H25	24.59	247165	470	B40	55	12.81	3.94	19.16	2.06	7.25	9.30	3.06	2.16	6.34
HXT715	315H15	15.23	247164												

Reducer Size	L	R Bolt	S	T		U	V	W	X	Z	CC	GG	HH
				Min.	Max.								
HXT1	1.06	0.38	2.50	23.81	29.63	7.13	3.75	3.19	9.94	1.91	4.50	2.66	0.94
HXT2	1.25	0.44	3.00	26.94	32.94	8.38	4.13	3.75	11.41	2.13	4.56	2.94	1.06
HXT3A	1.25	0.44	3.00	26.94	32.94	9.25	4.81	4.19	12.88	2.31	6.38	3.25	1.06
HXT4A	1.44	0.50	4.00	29.19	35.19	10.38	5.50	4.78	15.13	2.75	6.88	3.38	1.75
HXT5B	1.44	0.50	4.00	29.19	35.19	13.13	6.56	5.69	18.31	3.06	7.06	4.50	1.75
HXT6	2.75	0.63	4.75	29.19	35.19	15.13	7.56	6.75	21.31	4.09	7.63	4.56	2.00
HXT7	2.75	0.63	4.75	29.44	35.44	18.75	9.38	8.31	25.94	5.13	8.13	4.69	2.00

Note: All reducers on this page require bushings. Stock HXT Reducers are drilled for vertical mounting. Reducer includes motor adapter.

♥ See pages G2-28 thru G2-53 for bore and keyseat information and bushing part numbers.

♣ Made to order.

FEATURES/BENEFITS PAGE G2-3	NOMENCLATURE PAGE G2-11	SELECTION PAGE G2-81	RELATED PRODUCTS PAGE G2-152
--------------------------------	----------------------------	-------------------------	---------------------------------



HYDROIL TORQUE-ARM Shaft Mount Speed Reducers HXT105 THRU HXT505A TAPER BUSHED REDUCERS

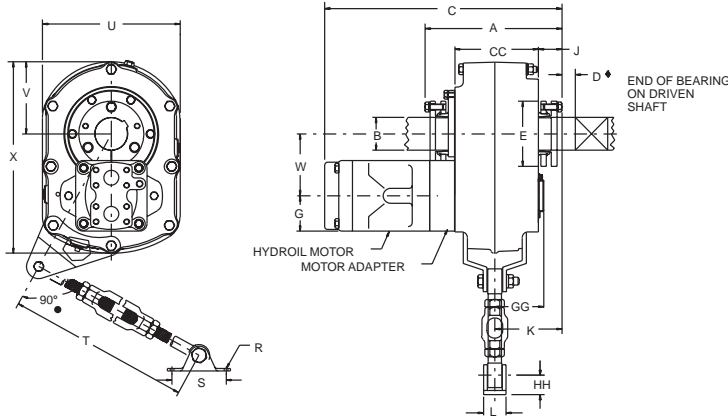

Reducer will operate satisfactorily at 90° or 180° from normal position shown in front view by relocating breather and drain plugs.

- ◆ Recommended minimum distance to loosen bushing using bushing screws as jack screws.

- The ideal position for the TORQUE-ARM is at right angles to a line between the point of attachment of the TORQUE-ARM to the reducer and the output shaft. This may vary up to 30° either way. **CAUTION:** Exceeding the ± 30° variance of the TORQUE-ARM could result in excessive reaction load and result in damage to the equipment.

HXT105 THRU HXT505A HYDROIL SINGLE REDUCTION TAPER BUSHED TORQUE-ARM SPEED REDUCERS

Reducer Size	AGMA Code	Gear Ratio	Part Number	Reducer Wt.	HYDROIL Motor		A	B Max. Bore	C	D	E	G	J	K	L
					Size	Wt.									
HXT105	107H05	5.62	241085	44	B30	30	5.63	1.44	14.97	1.25	3.25	2.38	1.28	3.53	1.06
HXT205	115H05	5.29	242251	56	B30	30	5.81	1.94	15.25	1.25	4.06	2.38	1.38	3.66	1.25
HXT305A	203H05	5.6	253153	90	B40	55	6.88	2.19	17.66	1.5	4.38	3.06	1.58	4.44	1.25
HXT405A	207H05	5.65	254202	126	B40	55	7.81	2.44	18.69	1.75	4.81	3.06	1.81	4.75	1.44
HXT505A	215H05	5.67	255202 ♣	186	B50	106	8.38	2.94	22	1.81	5.63	3.69	1.92	4.13	1.44

Reducer Size	R Bolt	S	T		U	V	W	X	CC	GG	HH
			Min.	Max.							
HXT105	0.38	2.50	23.81	29.63	7.13	3.75	3.25	9.94	4.50	2.64	0.94
HXT205	0.44	3.00	26.94	32.94	8.50	4.13	3.88	11.41	4.56	2.83	1.06
HXT305A	0.44	3.00	26.94	32.94	9.25	4.81	4.28	12.88	6.38	3.25	1.06
HXT405A	0.50	4.00	29.19	35.19	10.38	5.50	4.88	15.13	6.88	3.38	1.75
HXT505A	0.50	4.00	29.19	35.19	13.13	6.56	5.88	18.31	7.06	4.50	1.75

Note: All reducers on this page require bushings. Stock HXT Reducers are drilled for vertical mounting. Reducer includes motor adapter.

♥ See pages G2-28 thru G2-53 for bore and keyseat information and bushing part numbers.

♣ Made to order.

FEATURES/BENEFITS PAGE G2-3	NOMENCLATURE PAGE G2-11	SELECTION PAGE G2-81	RELATED PRODUCTS PAGE G2-152
--------------------------------	----------------------------	-------------------------	---------------------------------

SELECTION/DIMENSIONS



HYDROIL TORQUE-ARM Shaft Mount Speed Reducers HXT1 THRU HXT7 STRAIGHT BORE REDUCERS

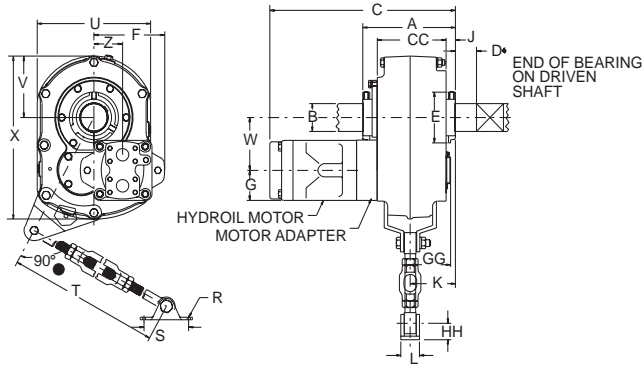

Reducer will operate satisfactorily at 90° or 180° from normal position shown in front view by relocating breather and drain plugs.

- The ideal position for the TORQUE-ARM is at right angles to a line between the point of attachment of the TORQUE-ARM to the reducer and the output shaft. This may vary up to 30° either way. **CAUTION:** Exceeding the ± 30° variance of the TORQUE-ARM could result in excessive reaction load and result in damage to the equipment.

HXT1 THRU HXT7 HYDROIL DOUBLE REDUCTION STRAIGHT BORE TORQUE-ARM SPEED REDUCERS

Reducer Size		AGMA Code		Gear Ratio		Part Number		Wt.	HYDROIL Motor		A	B Max. Bore ♥	C	E	F	G	J	K	L
15:1	25:1	15:1	25:1	15:1	25:1	15:1	25:1		Size	Wt.									
.....	HXT125	107H25	25.64	241078♣	49	A10	11	5.63	1.44	12.50	3.19	4.47	2.41	0.56	2.81	1.06
HXT115	107H15	15.35	241077♣	A20	11	5.81	1.94	12.63	3.56	4.69	2.41	0.63	2.91	1.25
.....	HXT215	115H15	115H25	14.10	23.46	242094	242095♣	65	A20	11	5.81	1.94	12.63	3.56	4.69	2.41	0.63	2.91	1.25
.....	HXT325A	203H25	24.71	243520	112	A20	11	7.81	2.19	13.69	4.00	4.88	2.41	0.63	2.47	1.25
HXT315A	203H15	14.88	243519	B30	30	8.22	2.44	14.50	5.75	7.23	2.38	0.84	3.88	1.44
HXT415A	HXT425A	207H15	207H25	15.13	24.38	244544	244545	143	B30	30	8.22	2.44	15.16	4.38	6.19	2.38	0.84	3.88	1.44
.....	HXT525B	215H25	25.56	245570	212	B30	30	8.66	2.94	15.94	5.13	6.50	2.38	1.00	4.13	1.44
HXT515B	215H15	15.40	245569	B40	55	9.63	3.44	16.69	5.63	7.25	3.06	1.00	4.81	2.75
HXT615	HXT625	307H15	307H25	15.33	25.13	246162	246163	293	B40	55	9.63	3.44	17.69	5.63	8.28	3.06	1.00	4.81	2.75
.....	HXT725	315H25	24.59	247173	470	B40	55	10.78	3.94	18.19	6.69	9.31	3.06	1.14	5.39	2.75
.....	HXT715	315H15	15.23	247172	B50	106	10.78	3.94	21.50	8.38	9.31	3.06	1.14	5.39	2.75

Reducer Size	R Bolt	S	T		U	V	W	X	Z	CC	GG	HH
			Min.	Max.								
HXT1	0.38	2.50	23.81	29.63	7.13	3.75	3.19	9.94	1.91	4.50	2.66	0.94
HXT2	0.44	3.00	26.94	32.94	8.38	4.13	3.75	11.41	2.13	4.56	2.94	1.06
HXT3A	0.44	3.00	26.94	32.94	9.25	4.81	4.19	12.88	2.31	6.38	3.25	1.06
HXT4A	0.50	4.00	29.19	35.19	10.38	5.50	4.78	15.13	2.75	6.88	3.38	1.75
HXT5B	0.50	4.00	29.19	35.19	13.13	6.56	5.69	18.31	3.06	7.06	4.50	1.75
HXT6	0.63	4.75	29.19	35.19	15.13	7.50	6.75	21.31	4.09	7.63	4.56	2.00
HXT7	0.63	4.75	29.44	35.44	18.75	9.38	8.31	25.94	5.13	8.50	4.69	2.00

Note: All reducers on this page require bushings. Stock HXT Reducers are drilled for vertical mounting. Reducer includes motor adapter.

♥ See pages G2-28 thru G2-53 for bore and keyseat information and bushing part numbers.

♣ Made to order.

FEATURES/BENEFITS PAGE G2-3	NOMENCLATURE PAGE G2-11	SELECTION PAGE G2-81	RELATED PRODUCTS PAGE G2-152
--------------------------------	----------------------------	-------------------------	---------------------------------



HYDROIL TORQUE-ARM Shaft Mount Speed Reducers HXT105 THRU HXT505A STRAIGHT BORE REDUCERS

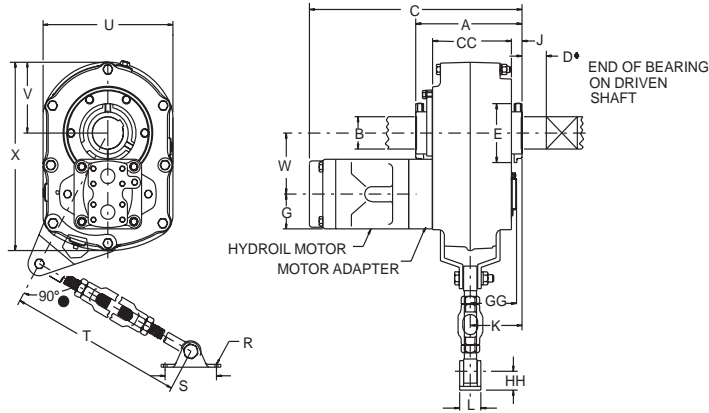

Reducer will operate satisfactorily at 90° or 180° from normal position shown in front view by relocating breather and drain plugs.

- The ideal position for the TORQUE-ARM is at right angles to a line between the point of attachment of the TORQUE-ARM to the reducer and the output shaft. This may vary up to 30° either way. **CAUTION:** Exceeding the ± 30° variance of the TORQUE-ARM could result in excessive reaction load and result in damage to the equipment.

HXT105 THRU HXT505A HYDROIL SINGLE REDUCTION STRAIGHT BORE TORQUE-ARM SPEED REDUCERS

Reducer Size	AGMA Code	Gear Ratio	Part Number	Reducer Wt.	HYDROIL Motor		A	B Max. Bore	C	D	E	G	J	K
					Size	Wt.								
HXT105	107H05	5.62	241089 ♣	44	B30	30	5.63	1.44	14.25	3.19	2.38	0.56	2.81	1.06
HXT205	115H05	5.29	242255	56	B30	30	5.81	1.94	14.5	3.56	2.38	0.63	2.91	1.25
HXT305A	203H05	5.6	253157	90	B40	55	7.41	2.19	16.69	4	3.06	0.63	4.44	1.25
HXT405A	207H05	5.65	254206 ♣	126	B40	55	8.22	2.44	17.72	4.38	3.06	0.84	4.75	1.44
HXT505A	215H05	5.67	255206 ♣	186	B50	106	8.66	2.94	21.06	5.13	3.69	1	4.13	1.44

Reducer Size	R Bolt	S	T		U	V	W	X	CC	GG	HH
			Min.	Max.							
HXT105	0.38	2.5	23.81	29.63	7.13	3.75	3.25	9.94	4.5	2.64	0.94
HXT205	0.44	3	26.94	32.94	8.5	4.13	3.88	11.41	4.56	2.83	1.06
HXT305A	0.44	3	26.94	32.94	9.25	4.81	4.29	12.88	6.38	3.25	1.06
HXT405A	0.5	4	29.19	35.19	10.38	5.5	4.88	15.13	6.88	3.38	1.75
HXT505A	0.5	4	29.19	35.19	13.13	6.56	5.88	18.31	7.06	4.15	1.75

Note: All reducers on this page require bushings. Stock HXT Reducers are drilled for vertical mounting. Reducer includes motor adapter.

♥ See pages G2-28 thru G2-53 for bore and keyseat information and bushing part numbers.

♣ Made to order.

FEATURES/BENEFITS PAGE G2-3	NOMENCLATURE PAGE G2-11	SELECTION PAGE G2-81	RELATED PRODUCTS PAGE G2-152
--------------------------------	----------------------------	-------------------------	---------------------------------

SELECTION/DIMENSIONS



HYDROIL Screw Conveyor Shaft Mount Speed Reducers

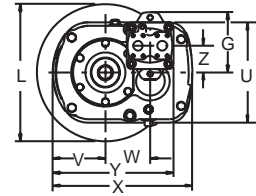
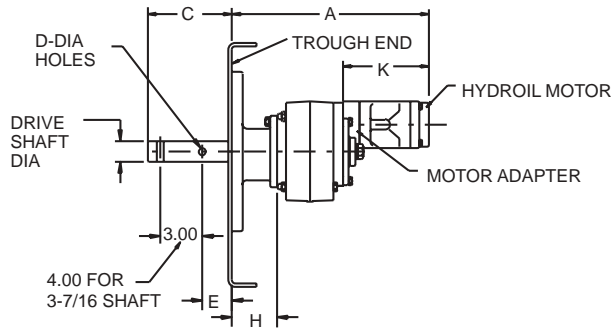

HSC1 THRU HSC7 DOUBLE REDUCTION HYDROIL SCREW CONVEYOR DRIVES †

Reducer Size	Drive Shaft Dia.	To Fit Screw Dia.	HYDROIL Motor		Parts When Ordering Separately											
					Reducer ■		CEMA Drive Shaft ★							Adapter Assy. ▲		
					Part Number		Wt.	Size	Part No.	Wt.	C	D	E	Size	Part No.	Wt.
					15:1	25:1										
HSC115	1-1/2	6, 9	A20	11	⊙	⊕	46	C1 x 1-1/2	351094	7.2	6.00	0.52	2.13	C1A	351086	17
	2	9, 12			⊙	⊕	46	C1 x 2	351095	9.1	6.00	0.64	2.13			
HSC125	2-7/16	12, 14	A10	11	⊙	⊕	46	C1 x 2-7/16	351096	12.5	6.69	0.64	2.75	C1B	351087	22
	3	12 thru 20			⊙	⊕	46	C1 x 3	351097	17.4	6.88	0.77	2.88			
HSC215	1-1/2	6, 9	A20	11	⊙	⊕	58	C2 x 1-1/2	352090	11.4	6.00	0.52	2.13	C2A	352052	20
	2	9, 12			⊙	⊕	58	C2 x 2	352091	13.8	6.00	0.64	2.13			
HSC225	2-7/16	12, 14	A20	11	⊙	⊕	58	C2 x 2-7/16	352092	17.3	6.69	0.64	2.75	C2B	352053	25
	3	12 thru 20			⊙	⊕	58	C2 x 3	352093	22.1	6.88	0.77	2.88			
HSC315A	1-1/2	9	B30	11	⊙	⊕	90	C3A x 1-1/2	243562	13.5	6.00	0.52	2.13	C3	353047	27
	2	9, 12			⊙	⊕		90	C3A x 2	243563	16	6.00	0.64			
HSC325A	2-7/16	12, 14	A20	30	⊙	⊕	90	C3A x 2-7/16	243564	19.5	6.69	0.64	2.75	C3	353047	27
	3	12 thru 20			⊙	⊕		90	C3A x 3	243565	26	6.88	0.77			
HSC415A	1-1/2	9	B30	30	⊙	⊕	113	C4A x 1-1/2	244594	19	6.00	0.52	2.13	C4	354121	31
	2	9, 12			⊙	⊕		113	C4A x 2	244595	20.8	6.00	0.64			
HSC425A	2-7/16	12, 14	B30	30	⊙	⊕	113	C4A x 2-7/16	244596	24.3	6.69	0.64	2.75	C4	354121	31
	3	12 thru 20			⊙	⊕		113	C4A x 3	244597	29.2	6.88	0.77			
HSC515B	1-1/2	9	B40	30	⊙	⊕	165	C4A x 3-7/16	244598	29.3	9.13	0.89	3.88	C5	355072	43
	2	9, 12			⊙	⊕		165	C5B x 2	355175	29.4	6.00	0.64			
HSC525B	2-7/16	12, 14	B30	55	⊙	⊕	165	C5B x 2-7/16	355176	33	6.69	0.64	2.75	C5	355072	43
	3	12 thru 20			⊙	⊕		165	C5B x 3	355177	37.9	6.88	0.77			
HSC615	3-7/16	18 thru 24	B40	55	⊙	⊕	225	C5B x 3-7/16	355178	48.3	9.13	0.89	3.88	C6	356055	56
	2-7/16	12, 14			⊙	⊕		225	C6 x 2-7/16	356042	47.7	6.69	0.64			
HSC625	3	12 thru 20	B40	55	⊙	⊕	225	C6 x 3	356043	52.7	6.88	0.77	2.88	C6	356055	56
	3-7/16	18 thru 24			⊙	⊕		225	C6 x 3-7/16	356044	63	9.13	0.89			
HSC715	2-7/16	12, 14	B50	55	⊙	⊕	390	C7 x 2-7/16	356182	65	6.69	0.64	2.75	C7	356187	72
	3	12 thru 20			⊙	⊕		390	C7 x 3	356183	70	6.88	0.77			
HSC725	3-7/16	18 thru 24	B40	106	⊙	⊕	390	C7 x 3-7/16	356184	80.3	9.13	0.89	3.88	C7	356187	72

FEATURES/BENEFITS PAGE G2-3	NOMENCLATURE PAGE G2-11	SELECTION PAGE G2-81	RELATED PRODUCTS PAGE G2-152
--------------------------------	----------------------------	-------------------------	---------------------------------



HYDROIL Screw Conveyor Shaft Mount Speed Reducers HSCT1 THRU HSCXT7 DOUBLE REDUCTION HYDROIL SCREW CONVEYOR DRIVES †

Reducer Size	Actual Ratio		Max. RPM of Shaft				A	G	H	K	L	U	V	W	X	Y	Z
	15:1	25:1	Input		Driven												
			15:1	25:1	15:1	25:1											
HSCXT1	15.35 25.64	2149 2179	140 85	15.34	4.47	3.22	7.44	♥	7.13	3.75	3.38	♥	9.34	1.91
HSCXT2	14.97	24.92	2096	2118	140	85	15.94	4.69	3.56	7.44	◆	8.38	4.09	3.77	◆	10.27	2.14
HSCXT3A	15.26 25.34	2136 2155	140 85	17.81 17.00	5.75 4.88	3.69	7.44	11.38	9.25	4.84	4.17	13.72	11.39 11.42	2.33
HSCXT4A	15.30	24.64	2142	2094	140	85	18.44	6.19	4.00	7.38	11.38	10.38	5.50	4.78	15.31	12.66	2.75
HSCXT5B	15.38 25.54	1919 2043	125 80	20.56 19.81	7.25 6.50	4.25	9.19 7.75	11.38	13.13	6.56	5.67	18.31	14.30 14.61	3.05
HSCXT6	15.33	25.13	1895	1985	125	80	21.81	8.28	5.50	9.31	11.38	15.13	7.56	6.73	21.31	17.36	4.09
HSCXT7	15.23 24.59	1767 1844	116 75	26.28 23.00	8.38 9.31	6.31	10.56 8.81	11.38	18.75	9.38	8.30	25.94	22.11 20.36	5.11

- † Complete drive consists of reducer, CEMA drive shaft with key, and adapter assembly. Drive is shipped unassembled.
- ▲ Includes adapter, necessary mounting bolts and seal retainer. Both lip type and braided type seals included for customer's choice of application.
- ★ CEMA drive shaft and key furnished unless otherwise specified. See pages G2-120 thru G2-122 for optional drive shafts available from DODGE.

- Reducer includes hydroil motor adapter.
- ♥ L=7", X=9.94" when using a C1A adapter; L=11.38", X=11.88" when using a C1B adapter.
- ◆ L=7", X=11.41" when using a C2A adapter; L=11.38", X=13" when using a C2B adapter.
- ♣ Made to order.

FEATURES/BENEFITS PAGE G2-3	NOMENCLATURE PAGE G2-11	SELECTION PAGE G2-81	RELATED PRODUCTS PAGE G2-152
--------------------------------	----------------------------	-------------------------	---------------------------------

SELECTION/DIMENSIONS



HYDROIL Screw Conveyor Shaft Mount Speed Reducers

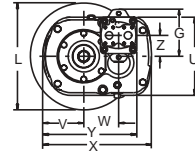
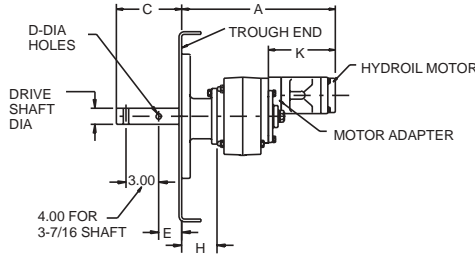

HSCT105 THRU HSCT505A SINGLE REDUCTION HYDROIL SCREW CONVEYOR DRIVES †

Reducer Size	Drive Shaft Dia.	To Fit Screw Dia	HYDROIL Motor		Parts When Ordering Separately													
					Reducer ■		CEMA Drive Shaft ★						Adapter Assy. ▲					
					Size	Wt.	Part No.	Wt.	Size	Part No.	Wt.	C	D	E	Size	Part No.	Wt.	
HSCXT105	1-1/2	6, 9	B30	30	♣ 351190	41	C1 x 1-1/2	351094	7.2	6.00	0.52	2.13	C1A	351086	17			
	2	9, 12				41	C1 x 2	351095	9.1	6.00	0.64	2.13						
	2-7/16	12, 14				41	C1 x 2-7/16	351096	12.5	6.69	0.64	2.75				C1B	351087	22
	3	12 thru 20				41	C1 x 3	351097	14.4	6.88	0.77	2.88						
HSCXT205	1-1/2	6, 9	B30	30	♣ 352190	53	C2 x 1-1/2	352090	11.4	6.00	0.52	2.13	C2A	352052	20			
	2	9, 12				53	C2 x 2	352091	13.8	6.00	0.64	2.13						
	2-7/16	12, 14				53	C2 x 2-7/16	352092	17.3	6.69	0.64	2.75	C2B	352053	25			
	3	12 thru 20				53	C2 x 3	352093	22.1	6.88	0.77	2.88						
HSCXT305A	1-1/2	9	B40	55	♣ 253160	79	C3A x 1-1/2	243562	13.5	6.00	0.52	2.13	C3	353047	27			
	2	9, 12				79	C3A x 2	243563	16.0	6.00	0.64	2.13						
	2-7/16	12, 14				79	C3A x 2-7/16	243564	19.5	6.69	0.64	2.75						
	3	12 thru 20				79	C3A x 3	243565	26.0	6.88	0.77	2.88						
HSCXT405A	1-1/2	9	B40	55	♣ 254209	101	C4A x 1-1/2	244594	19.0	6.00	0.52	2.13	C4	354121	31			
	2	9, 12				101	C4A x 2	244595	20.8	6.00	0.64	2.13						
	2-7/16	12, 14				101	C4A x 2-7/16	244596	24.3	6.69	0.64	2.75						
	3	12 thru 20				101	C4A x 3	244597	29.2	6.88	0.77	2.88						
	3-7/16	18 thru 24				101	C4A x 3-7/16	244598	39.3	9.13	0.89	3.88						
HSCXT505A	2	9, 12	B50	106	♣ 255209	160	C5B x 2	355175	29.4	6.00	0.64	2.13	C5	355072	43			
	2-7/16	12, 14				160	C5B x 2-7/16	355176	33.0	6.69	0.64	2.75						
	3	12 thru 20				160	C5B x 3	355177	37.9	6.88	0.77	2.88						
	3-7/16	18 thru 24				160	C5B x 3-7/16	355178	48.3	9.13	0.89	3.88						

Reducer Size	Actual Ratio	Max. RPM of Shaft		A	H	K	L	U	V	W	X	Y
		Input	Driven									
HSCXT105	5.62	2246	400	16.28	3.22	8.38	♥	7.13	3.75	3.27	♥	9.39
HSCXT205	5.62	2246	400	16.50	3.56	8.50	♦	8.38	4.09	3.86	♦	10.33
HSCXT305A	5.31	2124	400	20.00	3.69	10.31	11.38	9.25	4.84	4.28	13.72	12.19
HSCXT405A	5.27	2108	400	21.00	4.00	10.63	11.38	10.38	5.50	4.88	15.94	16.50
HSCXT505A	5.69	2275	400	22.00	4.25	11.72	11.38	13.00	6.56	5.86	18.31	16.86

- † Complete drive consists of reducer, CEMA drive shaft with key, and adapter assembly. Drive is shipped unassembled.
- ▲ Includes adapter, necessary mounting bolts and seal retainer. Both lip type and braided type seals included for customer's choice of application.
- ★ CEMA drive shaft and key furnished unless otherwise specified. See pages G2-120 thru G2-122 for optional drive shafts available from DODGE.
- Reducer includes hydroil motor adapter.
- ♥ L=7", X=9.94" when using a C1A adapter; L=11.38", X=11.88" when using a C1B adapter.
- ♦ L=7", X=11.41" when using a C2A adapter; L=11.38", X=13" when using a C2B adapter.
- ♣ Made to order.

FEATURES/BENEFITS PAGE G2-3	NOMENCLATURE PAGE G2-11	SELECTION PAGE G2-81	RELATED PRODUCTS PAGE G2-152
--------------------------------	----------------------------	-------------------------	---------------------------------



HYDROIL TORQUE-ARM Shaft Mount Speed Reducers HYDROIL VANE MOTORS

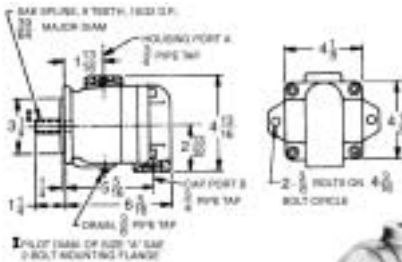

A10 & A20

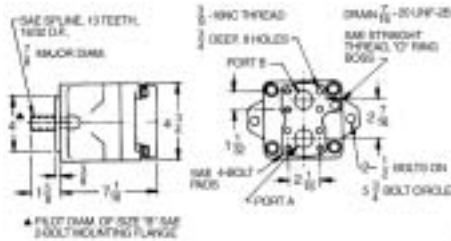

B30 (Port A and Port B, 1" dia.)

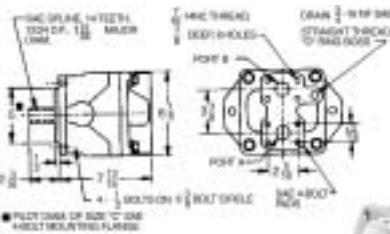

B40 (Port A and Port B, 1 1/4" dia.)

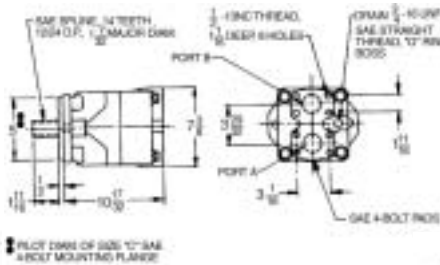

B50 (Port A and Port B, 2" dia.)



Hydroil Vane Motors are superior single stage vane type fluid motor. A series of internal ports admit oil to and carry it from the power element. Complete hydraulic balance of the assembly contributes to the mechanical efficiency and long life of these motors as well as to their unusually quiet operation. Other exclusive features assure a minimum of friction and efficient valving action regardless of operating speeds.

HYDROIL Vane Motors can be run in either direction of rotation. Flow into port A (see drawing) will result in clockwise rotation as viewed from shaft end of motor. Flow into port B will result in counterclockwise rotation.

Inlet and outlet ports on sizes A10 and A20 will accommodate standard tapered pipe fittings. Larger sizes will accommodate SAE split flanges.

Drains should be connected to tank with connections and hoses capable of withstanding 50 psi. No drain is required on sizes A10 and A20 if the housing port is the

low pressure port and is never subjected to more than 20 psi, in which case the motor drains internally.

HYDROIL Vane Motors for HXT Reducers

Motor Size	Part Number	Wt. (lbs)
A10	444049	11
A20	444050	11
B30	444054	30
B40	444055	55
B50	444056	106

NOTE: HXT1 thru HXT7 reducers are available in selected ratios to accommodate H, S, T and 2000-Series 6B spline, SAE "A" 2-bolt motors. See Related Products section for information on the HXT6B spline reducers.

FEATURES/BENEFITS PAGE G2-3	NOMENCLATURE PAGE G2-11	SELECTION PAGE G2-81	RELATED PRODUCTS PAGE G2-152
--------------------------------	----------------------------	-------------------------	---------------------------------



RELATED PRODUCTS

HYDROIL TORQUE-ARM Shaft Mount Speed Reducers CHAR-LYNN* COMPATIBLE 6B SPLINE REDUCER

New hydraulically powered DODGE TORQUE-ARM Twin Taper bushed speed reducers with 6B spline, SAE "A" 2-bolt motor flange. Suitable for Char-Lynn H, S, T and 2000 series motors or equal. This is a modified version of the famous TORQUE-ARM speed

- Twin Tapered Mounting
- Material Cost Savings
- Installed Cost Savings
- Simple Installation
- No Periodic Maintenance Cost Associated with Chain Drives
- Eliminate V-Drives
- Compact Drive Design
- Infinitely Adjustable Speeds/Torque
 - Driven machinery can be inched/jogged
 - Direction of rotation can be reversed
 - Low speed, high torque capability
- Shock Resistant Helical Gearing
- Reduced Motor Costs
- Optimized Pressure, Ratio and Flow
- No Motor Drain

Specifications

Reducer will be modified on the input section to facilitate the mounting of a basic Char-Lynn hydraulic motor or equivalent. This modification allows the mounting of H, S, T and 2000 series motors which must be equipped with a two-bolt SAE "A" flange (3.25 pilot diameter) and a 6B spline shaft (other comparably equipped motor brands will also work).

Reducer installation shall be accomplished by using ductile iron, fully split Twin Tapered bushings. Reducer removal shall be accomplished by providing jack screw holes in the bushing flanges to mechanically remove the tapered assembly.

*Char-Lynn is a registered trademark of EATON

Reducer Size	Double Reduction					Single Reduction		
	Input		Driven			Reducer Size	Input	Driven
	15	25	9	15	25			
HXT3 6B	-	2100	200	140	85	HXT105 6B	2246	400
HXT4 6B	2118	2072	200	140	85	HXT205 6B	2116	400
HXT5 6B	-	2044	200	125	80	HXT305 6B	2240	400
HXT6 6B	-	2010	200	125	80	HXT405 6B	2280	400
HXT7 6B	-	1844	200	125	75	HXT505 6B	2287	400

TORQUE-ARM Hydraulic Taper Bushed Speed Reducers

Reducer Size	Part Number	Exact Ratios	Max. Bore
HXT105T C/L 6B	251140	5.62	1.44
HXT205T C/L 6B	252140	5.29	1.94
HXT305AT C/L 6B	253140	5.60	2.19
HXT405AT C/L 6B	254140	5.65	2.44
HXT505AT C/L 6B	255160	5.67	2.94
HXT325AT CL 6B	243571	24.71	2.19
HXT415AT C/L 6B	244556	15.13	2.44
HXT425AT C/L 6B	244557	24.38	2.44
HXT525BT C/L 6B	245640	25.56	2.94
HXT625T C/L 6B	246520	25.13	3.44
HXT725T C/L 6B	247520	24.59	3.94

Motor Mounting Dimensions

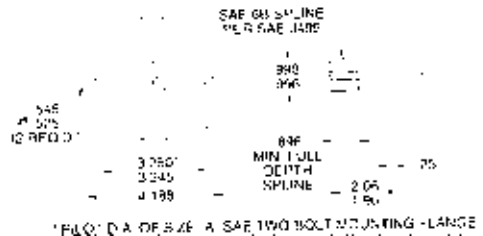

RELATED PRODUCTS



Gearing Reference Guide

HYDROIL TORQUE-ARM Shaft Mount Speed Reducers

Class I- Refer to pages G2-16 thru G2-18 - to determine appropriate drive service factor for your specific application and duty cycle. Refer to tables below for reducer Class I ratings.

Class II- Refer to pages G2-16 thru G2-18 to determine appropriate drive service factor for your specific application and duty cycle. To obtain Class II reducer ratings, divide Class I ratings from the tables below by 1.4.

Class III- Refer to pages G2-16 thru G2-18 to determine appropriate drive service factor for your specific application and duty cycle. To obtain Class III reducer ratings, divide Class I ratings from the tables below by 2.0.

Continuous Input Horsepower - Class I*

Output RPM	Reducer Size										
	HXT105 C/L	HXT205 C/L	HXT305A C/L	HXT405A C/L	HXT505A C/L	HXT325A C/L	HXT415A C/L	HXT425A C/L	HXT525B C/L	HXT625 C/L	HXT725 C/L
1	0.06	0.11	0.16	0.22	0.33	0.17	0.26	0.26	0.44	0.69	1.00
5	0.26	0.52	0.72	1.01	1.55	0.84	1.29	1.29	2.18	3.46	4.98
10	0.50	0.99	1.41	1.96	3.04	1.68	2.52	2.52	4.35	6.89	9.66
20	0.98	1.95	2.45	3.88	6.05	3.30	4.98	4.98	8.38	13.37	18.68
30	1.47	2.09	4.14	5.78	8.74	4.90	7.33	7.33	12.24		
40	1.95	3.85	5.51	7.64	11.13		9.52				
50	2.43	4.81	6.88	9.55	13.51		11.57				
60	2.70	5.34	7.92	11.07							
70	2.95	5.86	8.97	12.46							
80	3.22	6.38	10.01	13.85							
90	3.48	6.92	11.06	15.29							
100	3.75	7.44	12.10	16.83							
110	3.77	7.48	12.53								
120	3.98	7.92	13.46								
130	4.21	8.37	14.41								
140	4.42	8.81									
150	4.66	9.27									
160	4.87	9.71									

* INPUT HP-HP rating of reducer at input shaft under continuous operation after load has been started.

Continuous Output Torque - Class I**

Output RPM	Reducer Size										
	HXT105 C/L	HXT205 C/L	HXT305A C/L	HXT405A C/L	HXT505A C/L	HXT325A C/L	HXT415A C/L	HXT425A C/L	HXT525B C/L	HXT625 C/L	HXT725 C/L
1	3470	6980	9580	13500	20100	10400	16000	16000	27000	42700	61600
5	3200	6380	8950	12500	19200	10400	16000	16000	27000	42700	61600
10	3100	6140	8700	12100	18800	10400	15600	15600	26900	42600	59700
20	3040	6020	8580	12000	18700	10200	15400	15400	25900	41300	57700
30	3020	5980	8530	11900	18000	10100	15100	15100	25200		
40	3010	5950	8510	11800	17200		14700				
50	3000	5940	8500	11800	16700		14300				
60	2780	5500	8160	11400							
70	2600	5170	7920	11000							
80	2490	4930	7730	10700							
90	2390	4750	7590	10500							
100	2320	4600	7480	10400							
110	2120	4200	7040								
120	2050	4080	6930								
130	2000	3980	6850								
140	1950	2890									
150	1920	3820									
160	1880	3750									

** OUTPUT TORQUE - Continuous output torque rating of reducer (in-lbs)

PEAK HP - Momentarily, peak horsepower may be very high. For example, in applications with high inertia loads, oversize or high torque motors, etc.

Where this momentary peak exceeds 200% of normal (100% overload) the equivalent HP may be obtained by dividing the peak HP by two. If the results exceed the horsepower obtained from a consideration of service and duty, it should be used to select the reducer size.

NOTE: Below 15 RPM output speed, oil level must be adjusted to reach highest oil level plug (P).

FEATURES/BENEFITS PAGE G2-3	NOMENCLATURE PAGE G2-11	SELECTION/DIMENSIONS PAGE G2-144	RELATED PRODUCTS PAGE G2-152
--------------------------------	----------------------------	-------------------------------------	---------------------------------

TORQUE-ARM II

TORQUE-ARM

MAXIMUM Concentric Reducer

TIGEAR-2

RELATED PRODUCTS



HYDROIL TORQUE-ARM Shaft Mount Speed Reducers HARSH DUTY ACCESSORIES

XT CORROSION RESISTANCE

Epoxy Paints

Standard factory paint is a high quality true two-part epoxy suitable for incidental food contact by the USDA. This enhancement coating offers excellent chemical resistance, salt spray resistance and resists hostile elements of wash-down or harsh outdoor environments. Color options for this coating offered are black and white. Factory cycle item.

Zinc Plated Fasteners

Includes all housing and Torque-Arm rod fasteners. Factory assembled.

Teflon Coated Tapered Bushings*

All exposed surfaces coated for tough, resilient protection with black Teflon (DODGE S293D). Zinc plated fasteners included. Tested 1,000,000 starts & stops, outdoors in caustic spray. Factory cycle item.

*Patented or patents pending

CEMA Stainless Steel Drive Shafts for Screw Conveyor Drives

#316 stainless steel, three hole construction now available on short cycle delivery. Consult DODGE for delivery.

XT Hostile Environments

Filter Breather

Optional 40 micron filter with cap. Combats dust, dirt and wet environments. Replaces standard breather assembly. Stock item.

Enclosed Breather Chamber

Elastic diaphragm enclosed in steel chamber provides closed system. Protects reducer components and lubricant in wet, dusty or hot environments. Install in new reducer installations only. Mounts in uppermost position and replaces standard breather. Stock item.

Oil Sump Heater

110 volt, single phase, AC cartridge heater, threads into standard tapped drain hole. Provides approximately 70_F temperature rise in one hour for cold climates. Simple time phased on/off construction. Standard oil sump heater does not come with thermostat. Factory cycle item.

CEMA AC Packing Gland Adaptor

For tough, abrasive environments. Protects reducer from contamination. Open center cavity for dropout. Multiple braided felt seal rings. Repack without removal. Stock item.

Long Term Storage

Preparation for long storage or delayed job start-up. Reducer is protected internally with a vapor phase corrosion inhibiting oil. Breather removed and reducer sealed with pipe plug. Factory cycle item.

FEATURES/BENEFITS PAGE G2-3	NOMENCLATURE PAGE G2-11	SELECTION/DIMENSIONS PAGE G2-144	RELATED PRODUCTS PAGE G2-152
--------------------------------	----------------------------	-------------------------------------	---------------------------------



HYDROIL TORQUE-ARM Shaft Mount Speed Reducers HARSH DUTY ACCESSORIES

XT SAFETY & SEALING

Metal End Covers, Open, Closed and Split

- Protection for oil seal areas and from rotating components. Enhances seal life.
- Closed or open for input shaft side. Two piece split for backstop side.
- Simply position on reducer, drill holes and insert self tapping screws. Stock item.

Oil Filter System (TXT 4A-12)*

Oil cycles through standard filter several times daily. Simply bolt kit to backstop area and connect to standard drain. Reduces maintenance, extends lubricant life and minimizes wear factors. No pumps required. Mounting position B only.

Stock item.

*Patented or patents pending.

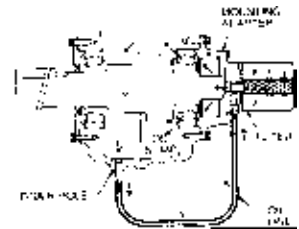

Extended life high temperature and abrasion resistant XT harsh duty oil seals (TXT 5B-10 double reduction.) Stocked individually or installed to order. Optional feature.

The addition of lithium sterate aluminate to the XT harsh duty seal compound acts as a friction-reducing, antiwear additive resulting in extended service life. XT harsh duty seals provide 4 to 6 times the abrasion resistance of standard nitrile seals, resulting in lower seal life and less unscheduled downtime. As oil temperature increases, seal life may be reduced. With standard nitrile seals, the increase in temperature from 200°F to 225°F can reduce seal life up to 50% as the seal lip gets brittle and cracks. XT harsh duty seals will handle up to 350°F (176°C), a 40% increase in temperature capability over standard nitrile seals.

Note: Contact DODGE if oil sump temperature exceeds 200°F maximum with petroleum lubricants.

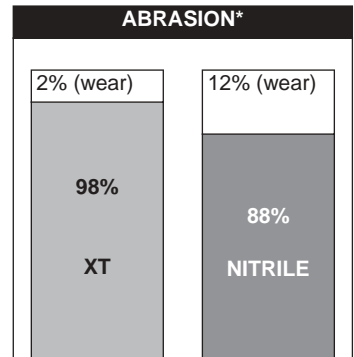

* Run in accordance with ASTM D-3389

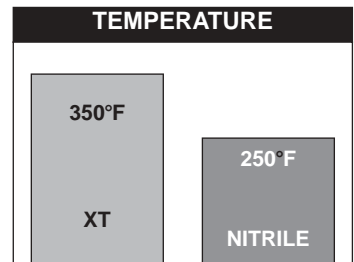

Belt Guards, Backstops

Stock items. Rugged slotted metal construction with welded straps. No drilling required to install. Includes mounting hardware and bolts to reducer and motor mount. Backstops prevent reversing and allow for either direction of operation.

Input Auxiliary Seal

Metal cover with internal V-Seal/Labyrinth construction. Complete with lubrication filling or no-lub plug. Combats dust, dirt and moisture. Protects high speed oil seal. Stock item.

FEATURES/BENEFITS PAGE G2-3	NOMENCLATURE PAGE G2-11	SELECTION/DIMENSIONS PAGE G2-144	RELATED PRODUCTS PAGE G2-152
--------------------------------	----------------------------	-------------------------------------	---------------------------------



RELATED PRODUCTS

HYDROIL TORQUE-ARM Shaft Mount Speed Reducers

HARSH DUTY ACCESSORIES

XT LUBRICATION

- Oil level sight gauge. Stock item
- New DODGE/AGMA/ISO viscosity standards
- New higher viscosity lubricant selections
- Brand options

Maximizing productivity and uptime is paramount in today's industry. By following some simple recommendations on lubrication, OEMs and users can improve product performance and reduce downtime. Remember, the purpose of speed reducer lubrication is to minimize frictional forces, eliminate wear and dissipate heat.

The American Gear Manufacturing Association (AGMA) and ISO have recently changed their lubrication standards.

This change was necessitated by the increased horsepower that helical gearing is asked to transmit. As a result, higher ISO viscosity grades have been selected. The proper oil viscosity is based upon ambient temperature and gearing pitch line velocity. DODGE has converted pitch line velocity into reducer output speed (RPM).

RECOMMENDED LUBRICANTS FOR TORQUE-ARM REDUCERS +					
With or Without Backstop			EP Oils Without Backstops		
EXXON					
150	Teresstic	150	Spartan EP	150	
220		220		220	
320		320		320	
CHEVRON					
150	Machine	150	Gear Compound	150	
220		220	EP	220	
320		320		320	
UNICAL					
150	Turbine Oil	150	Extra Duty HL	141	
220		220	Gear Lube	207	
320		320		300	
MOBIL SYNTHETIC					
150	SHC	629	SHC	629	
220	SHC	630	SHC	630	
320	SHC	632	SHC	632	
MOBIL					
150	Mobil DTE	BB	Mobil Gear	629	
220	Extra Heavy	AA		630	
320				632	
TEXACO					
150	Regal Oil R&O	150	Meropa	150	
220		220		220	
320		320		320	
SHELL					
150	Morlina Oil	150	Omala	150	
220		220		220	
320		320		320	

For further lubrication information, refer to DODGE TORQUE-AMR lubrication Manual 499336 or individual product manuals.

+Partial list. Consult DODGE or a lubricant manufacturer for further options.

FEATURES/BENEFITS PAGE G2-3	NOMENCLATURE PAGE G2-11	SELECTION/DIMENSIONS PAGE G2-144	RELATED PRODUCTS PAGE G2-152
--------------------------------	----------------------------	-------------------------------------	---------------------------------

RELATED PRODUCTS



TORQUE-ARM Shaft Mount Speed Reducers HARSH DUTY & SENSORIZED ACCESSORIES

Product	Part #	Product	Part #
TXT4 Oil Filter Kit	244698	TXT2 Taconite Aux Seal Kit	272446
TXT5 Oil Filter Kit	245698	TXT205 Taconite Aux Seal kit	272459
TXT6 Oil Filter Kit	246698	TXT305A Taconite Aux Seal Kit	253186
TXT7 Oil Filter Kit	247698	TXT3A Taconite Aux Seal Kit	243577
TXT8 Oil Filter Kit	248488	TXT405A Taconite Aux Seal Kit	254267
TXT9 Oil Filter Kit	249488	TXT4A Taconite Aux Seal Kit	244676
TXT10 Oil Filter Kit	250448	TXT505A Taconite Aux Seal Kit	255230
TXT12 Oil Filter Kit	252198	TXT5B Taconite Aux Seal Kit	245635
TXT Encl Breather Sys. Sm (1-10)	240050	TXT6 Taconite Aux Seal	272450
TXT Encl Breather Sys. Lg. (12-15)	240051	TXT7 Taconite Aux Seal Kit	272451
TXT 5D Harsh Duty Input Seal	245543	TXT8 Taconite Aux Seal Kit	272452
"TXT 6D, 7D, 705 XT Duty Input Seal"	246543	TXT9 Taconite Aux Seal Kit	272453
"TXT8-10D, 805, 905, XT Duty I/P Seal"	248443	TXT10 Taconite Aux Seal Kit	272454
TXT 5D Harsh Duty Output Seal	245444	TXT12 Taconite Aux Seal Kit	272455
TXT 6D Harsh Duty Output Seal	246444	TD113 Taconite Aux Seal Kit	272456
TXT 7D Harsh Duty Output Seal	247444	TD114 Taconite Aux Seal Kit	272457
TXT 8D Harsh Duty Output Seal	248444	TD115 Taconite Aux Seal Kit	272458
TXT 9D Harsh Duty Output Seal	249444	3/8 Sight Oil Level Gauge (TXT1-4)	* 430120
TXT 10D Harsh Duty Output Seal	250444	1/2 Sight Oil Level Gauge (TXT5-6)	* 430121
3/8 Filter Breather Plug	430048	3/4 Sight Oil Level Gauge (TXT7-TDT15)	* 430159
1/2 Filter Breather Plug	430049	C1x1-1/2 3H SS Drive Shaft	351025
Pressure Breather Vent Plug	* 6-030657	C1x2 3H SS Drive Shaft	351026
TXT 1-4 Immersion Heater	241103	C2x1-1/2 3H SS Drive Shaft	352186
TXT 5-6 Immersion Heater	241104	C2x2 3H SS Drive Shaft	352187
TXT 7-10 Immersion Heater	241105	C3Ax2 3H SS Drive Shaft	353181
TXT1 SS Cls Aux Cvr Asy	246601	C3Ax2-7/16 3H SS Drive Shaft	353182
TXT1 SS Opn Aux Cvr Asy	246602	C4Ax2 3H SS Drive Shaft	354352
TXT1 BS Split Aux Cvr Asy	246603	C4Ax2-7/16 3H SS Drive Shaft	354353
TXT2 SS Cls Aux Cvr Asy	246604	C4Ax3 3H Ss Drive Shaft	354354
TXT2 SS Opn Aux Cvr Asy	246605	C5Bx2-7/16 3H Ss Drive Shaft	355226
TXT2 BS Split Aux Cvr Asy	246606	C5Bx3 3H SS Drive Shaft	355227
TXT3A SS Cls Aux Cvr Asy	246607	C6x3 3H SS Drive Shaft	356276
TXT3A SS Opn Aux Cvr Asy	246608	C7x3-7/16 3H Ss Drive Shaft	356283
TXT3A BS Split Aux Cvr Asy	246609	AC1B Adj. Pack Adpt Asy	356168
TXT4A SS Cls Aux Cvr Asy	246610	AC2B Adj Pack Adpt Asy	356112
TXT4A SS Opn Aux Asy	246611	AC3B Adj Pack Adpt Asy	356163
TXT4A BS Split Aux Cvr Asy	246612	AC4 Adj Pack Adpt Asy	356149
TXT5B SS Cls Aux Cvr Asy	246616	AC5 Adj Pack Adpt Asy	356158
TXT5B SS Opn Aux Cvr Asy	246617	AC6 Adj Pack Adpt Asy	356154
TXT5B SS BS Split Aux Cvr Asy	246618	AC7 Adj Pack Adpt Asy	356192
TXT6 SS Cls Aux Cvr Asy	246619	SCXT1 Taconite Aux Seal Kit	272721
TXT6 SS Opn Aux Cvr Asy	246620	SCXT2 Taconite Aux Seal Kit	272722
TXT6 BS Split Aux Cvr Asy	246621	SCXT3A Taconite Aux Seal Kit	243582
TXT7 SS Cls Aux Cvr Asy	246622	SCXT4A Taconite Aux Seal Kit	244677
TXT7 SS Opn Aux Cvr Asy	246623	SCXT5B Taconite Aux Seal Kit	245637
TXT7 BS Split Aux Cvr Asy	246624	SCXT505A Taconite Aux Seal Kit	255148
TXT8 SS Cls Aux Cvr Asy	246625	SCXT6 Taconite Aux Seal Kit	272726
TXT8 SS Opn Aux Cvr Asy	246625	SCXT7 Taconite Aux Seal Kit	272727
TXT8 BS Split Aux Cvr Asy	246627	TXT/SCXT 1 Input Taconite Seal	241102
TXT9 SS Cls Aux Cvr Asy	246628	TXT/SCXT 2 Input Taconite Seal	242102
TXT9 SS Opn Aux Cvr Asy	246629	TXT/SCXT 3A Input Taconite Seal	243108
TXT9 SS Split Aux Cvr Asy	246630	TXT/SCXT 4A Input Taconite Seal	244117
TXT10 SS Cls Aux Cvr Asy	246631	TXT/SCXT 5B Input Taconite Seal	245104
TXT10 SS Opn Aux Cvr Asy	246632	TXT/SCXT 6, 605 Input Taconite Seal	246102
TXT10 SS Split Aux Cvr Asy	246633	TXT/SCXT 7, 705 Input Taconite Seal	247102
TXT12 SS Cls Aux Cvr Asy	246634	TXT 8, 805 Input Taconite Seal	248102
TXT12 SS Opn Aux Cvr Asy	246635	TXT 9, 905 Input Taconite Seal	249102
TXT12 SS Split Aux Cvr Asy	246635	TXT 10 Input Taconite Seal	250102
TXT105 BS SPL Aux Cvr Asy	246613	TXT 12 Input Taconite Seal	242102
TXT205 BS SPL Aux Cvr Asy	246614	TXT/SCXT 105 Input Taconite Seal	241109
TXT305 BS SPL Aux Cvr Asy	246615	TXT/SCXT 205 Input Taconite Seal	242109
TXT1 Taconite Aux Seal Kit	272515	TXT/SCXT 305A Input Taconite Seal	243109
TXT105 Taconite Aux Seal Kit	272521	TXT/SCXT 405A Input Taconite Seal	244159
		TXT/SCXT 505A Input Taconite Seal	245106

* Available as Renewal Parts

FEATURES/BENEFITS PAGE G2-3	NOMENCLATURE PAGE G2-11	SELECTION/DIMENSIONS PAGE G2-144	RELATED PRODUCTS PAGE G2-152
--------------------------------	----------------------------	-------------------------------------	---------------------------------



RELATED PRODUCTS

TORQUE-ARM Shaft Mount Speed Reducers TXT-ABHS AIRPORT BAGGAGE HANDLING SYSTEM REDUCER FOR CONVEYORS

With 50 years of proven dependability and more than 1.5 million units in service throughout the world, DODGE TORQUE-ARM speed reducers are the standard of the industry.

SHAFT MOUNT CONCEPT

Twin-Tapered Mounting to the Driven Shaft

Material Cost Savings

- Eliminates support structures
- Eliminates chain, sprocket or coupling

Installed Cost Savings

- No installation and alignment of chains or coupling
- Simple installation and motor alignment

Compact Flexible Drive Design

- Space Savings
- Reducer mounts 360° around the shaft

Flexibility to Change Output Speed

- Ease of changing V-belt drives
- Economical to change speeds
- Ability to fine tune speeds at a later date

Efficiency

- 98.5% per gear stage

Hollow Bore

- Exclusive Twin-Tapered bushings
- Wide range of bore sizes

Performance

- Oversized input bearings and shaft for extended duty hours and service
- New premium material oil seals for continuous duty operation
- 100% factory tested and shipped with mobil DTE-BB premium lubrication
- Zinc plated torque arm rods for corrosion resistance
- Thousands of units in operation
- Maintenance Free
- Ease of repair, fewer spares, high parts availability
- Designed with years of industry analysis and research

Interchanges with Standard DODGE TXT Dimensions and Ratios

36/12 Warranty

Meets or Exceeds AGMA Standards

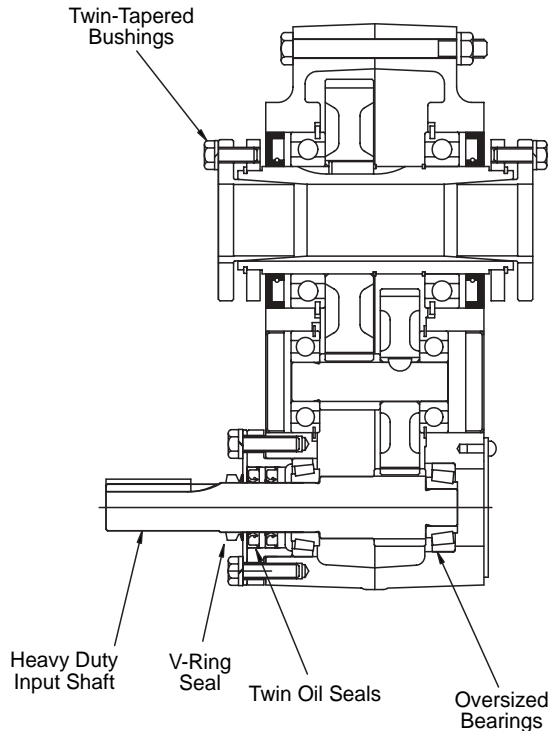

FEATURES/BENEFITS PAGE G2-3	NOMENCLATURE PAGE G2-11	SELECTION/DIMENSIONS PAGE G2-144	RELATED PRODUCTS PAGE G2-152
--------------------------------	----------------------------	-------------------------------------	---------------------------------

RELATED PRODUCTS



TORQUE-ARM Shaft Mount Speed Reducers

TXT-ABHS AIRPORT BAGGAGE HANDLING SYSTEM REDUCER FOR CONVEYORS



DODGE TORQUE-ARM Speed Reducer. The speed reducer shall be either a belt driven or direct coupled enclosed shaft mount type unit with a single or double reduction ratio. The reducer shall mount directly on the driven shaft and utilize an adjustable TORQUE-ARM that attaches from the gear case to the support structure or foundation.

The reducer housing shall be constructed of two-piece corrosion resistant, gray or ductile iron. All housings shall be doweled and precision machined.

All gearing shall be helical design and crown shaved. All gears shall be case carburized to ensure a high surface durability with a resilient tooth core for greater impact resistance and longer service life. Gears shall be supported between bearings to maintain proper alignment of gear meshes.

Reducer bearings shall be ball or tapered roller type. All seals are premium material for continuous duty operation. Dual seals and V-ring seal on input.

Reducer gears and bearings shall be splash lubricated using a premium lubricant.

Reducer installation shall be accomplished by using ductile iron, fully split Twin Tapered bushings.

Reducer removal shall be accomplished by providing jack screw holes in the bushing flanges to mechanically remove the tapered assembly.

TORQUE-ARM Speed Reducers

Size	Part Number
TXT 125T ABHS Reducer▲	241153+
TXT 115T ABHS Reducer▲	241155+
TXT 109T ABHS Reducer▲	241154+
TXT 105T ABHS Reducer▲	251120
TXT 225T ABHS Reducer▲	242258
TXT 215T ABHS Reducer▲	242257
TXT 209T ABHS Reducer▲	242259
TXT 205T ABHS Reducer▲	252120
TXT 325T ABHS Reducer	243251
TXT 315T ABHS Reducer	243252
TXT 309T ABHS Reducer	243253
TXT 305T ABHS Reducer	253199
TXT 425T ABHS Reducer	244251
TXT 415T ABHS Reducer	244252
TXT 409T ABHS Reducer	244253
TXT 405T ABHS Reducer	254199
TXT 525T ABHS Reducer	245251
TXT 515T ABHS Reducer	245252
TXT 509T ABHS Reducer	245253
TXT 505T ABHS Reducer	255199
TXT 1 ABHS TA Assembly★	241213
TXT 2 ABHS TA Assembly★	242280
TXT 3 ABHS TA Assembly★	243254
TXT 4 ABHS TA Assembly★	244254
TXT 5 ABHS TA Assembly★	245254

+15/16" diameter input shaft.

▲ Backstops not available.

★ TORQUE-ARM assembly does not come with the TXT ABHS Reducer. it must be ordered separately by the above part number

Taper Bushing Assemblies Taper Bushed Speed Reducers

Stock Bore	Reducer	Size	Part No.
1-7/16(Max.)	TXT ABHS1	TDT1	241292
1-3/8			241294
1-5/16 ▲			241290
1-1/4 ▲			241288
1-3/16 ▲			241286
1-1/8 ▲			241282
1-1/16 ▲			241280
1 ▲			241278
1-15/16(Max.)	TXT2 ABHS	TDT2	242168
1-3/4			242166
1-11/16			242164
1-5/8 ▲			242162
1-1/2 ▲			242158
1-7/16 ▲			242156
1-3/8 ▲			242154
1-5/16			242152
1-1/4 ▲			242150
1-3/16 ▲			242148
1-1/8 ▲			242146
2-3/16(Max.)			TXT3 ABHS
2	243274		
1-15/16	243272		
1-7/8 ▲	243270		
1-3/4 ▲	243266		
1-11/16 ▲	243268		
1-5/6 ▲	243264		
1-1/2 ▲	243262		
1-7/16 ▲	243260		
1-3/6 ▲	243284		
1-5/16 ▲	243282		
2-7/16(Max.)	TXT4 ABHS	TDT4	
2-1/4 ▲			244113
2-3/16 ▲			244111
2-1/8 ▲			244109
2 ▲			244095
1-15/16 ▲			244093
1-3/4 ▲	244087		
1-11/16 ▲	244085		
1-1/2 ▲	244081		
1-7/16 ▲	244079		
2-15/16(Max.)	TXT5 ABHS	TDT5	245112
2-11/16			245110
2-7/16 ▲			245094
2-1/4 ▲			245092
2-3/16 ▲			245090
2 ▲			245088
1-15/16 ▲	245086		

▲ Check driven shaft and key for strength.

FEATURES/BENEFITS PAGE G2-3	NOMENCLATURE PAGE G2-11	SELECTION/DIMENSIONS PAGE G2-144	RELATED PRODUCTS PAGE G2-152
--------------------------------	----------------------------	-------------------------------------	---------------------------------

RELATED PRODUCTS



TORQUE-ARM Shaft Mount Speed Reducers DODGE BIOLOGICAL CONTACT DRIVE (BIO-DISC) INDUSTRIAL DRIVE FOR WASTEWATR TREATMENT INDUSTRY

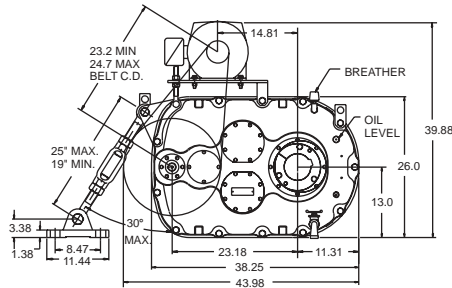

#188 L.H. BIO-DISC ASSY

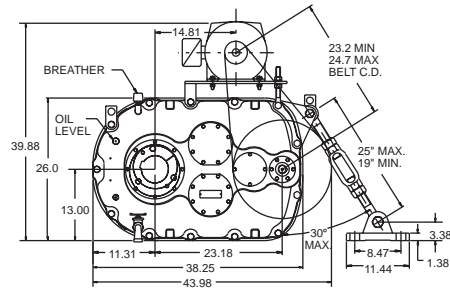

#188 R.H. BIO-DISC ASSY

PRODUCT SPECIFICATION

The speed reducer shall be either a belt driven or direct coupled enclosed shaft mount type unit with a triple reduction ratio of 170.44:1. The reducer shall mount directly on the driven shaft and utilize an adjustable TORQUE-ARM that attaches to the support structure or foundation.

The reducer housing shall be constructed of two-piece corrosion resistant, gray iron and be ribbed for added strength. All housings shall be doweled and precision machined to assure accurate alignment for all gear sets. The reducer housing shall be painted with primer plus two (2) coats of epoxy ester enamel to minimize corrosion.

All gearing shall be of helical or spur design, and crown shaved to provide an ellipsoid tooth to eliminate tooth end bearing and assure meshing at the strongest tooth area. All gears shall be case carburized to ensure a high surface durability with a resilient tooth core for greater impact resistance and long service life. Gears shall be supported between bearings to maintain proper alignment on gear meshes, to maximize load carrying capabilities, and eliminate overhung loads imposed on bearings. The gears shall be rated for 7-1/2 horsepower at 1.5 RPM - Class I service and 5 horsepower at 1.5 RPM - Class II Service. Reducer bearings shall be of the straight or tapered roller type and provide a 5,000 hour minimum L-10 life at the 7-1/2 HP Class I rating.

All seals shall be of the lip, spring loaded type, made of nitrile rubber.

Reducer gears and bearings shall be splash lubricated using a quality petroleum base oil, containing anti-foamants and rust inhibitors.

Reducer installation shall be accomplished by using ductile iron, fully split twin-tapered bushings. The maximum and

preferred bore shall be 4-15/16 inch. Reducer removal shall be accomplished by providing jack screw holes in the bushing flanges to mechanically remove the tapered assembly.

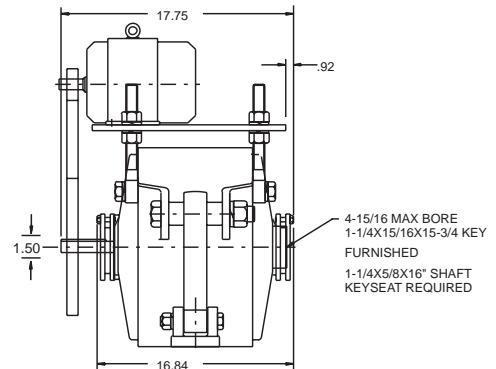

DODGE 188D BIO-DISC DRIVE PRODUCTS

PRODUCT DESCRIPTION	PART NO.	WEIGHT LBS.
188D BIO DISC REDUCER LH ASSEMBLY	259166 *	1392.0
188D BIO DISC REDUCER RH ASSEMBLY	259164 *	1392.0
188D BIO DISC REDUCER REPLACEMENT BUSHING ASSY	021832	20.8
BIO DISC REDUCER V-DRIVE KIT	BIO DR KIT **	50.0
188D LH BELT GUARD ASSEMBLY	259023	125.0
188D RH BELT GUARD ASSEMBLY	259024	125.0

* Consists of Reducer, Tapered Bushing Assembly and Motor Mount.

** Consists of 3/3V4.12/3V19.0/3VX850 V-drive with Taper Lock Bushings

FEATURES/BENEFITS PAGE G2-3	NOMENCLATURE PAGE G2-11	SELECTION/DIMENSIONS PAGE G2-144	RELATED PRODUCTS PAGE G2-152
--------------------------------	----------------------------	-------------------------------------	---------------------------------

RELATED PRODUCTS



TORQUE-ARM Shaft Mount Speed Reducers

DODGE V-BELT DRIVES FOR TORQUE-ARM REDUCERS AND SCREW CONVEYOR DRIVE REDUCERS

These are typical drives for average service conditions. For other conditions, output speeds or motor speeds, see reducer specifications for minimum driven sheave diameter and use V-belt drive selection tables.

For adequate horsepower, 3v, 5v, and 8v sheaves require 3VX, 5VX and 8VX belts; and A, B, C and D sheaves require AX, BX, CX and DX belts.

Keep driven sheave as close to reducer housing as possible.

The belt drive may be located in any convenient position. If the torque-arm is to be used to tighten the belts, the drive should be at about 90° to a line between the input and output shafts.

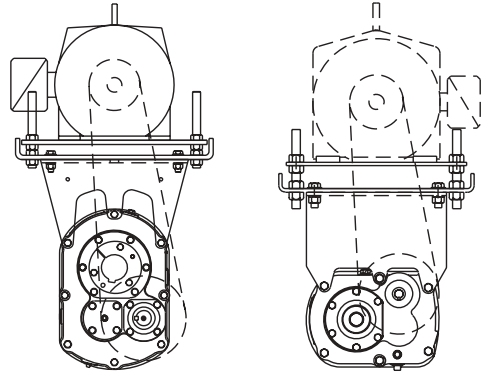
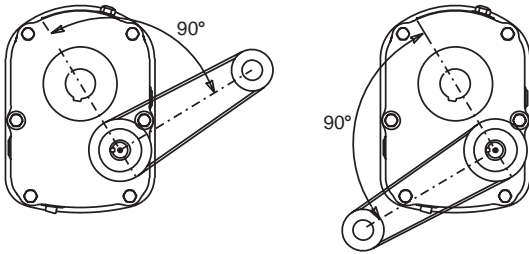

TABLE 19 - NEMA MOTOR INFORMATION (1750 RPM)

Horsepower	NEMA Motor Frame	Shaft Diameter	Minimum Sheave Diameters
1	143T	7/8	2.20
1-1/2	145T	7/8	2.40
2	145T	7/8	2.40
3	182T	1-1/8	2.40
5	184T	1-1/8	3.00
7-1/2	213T	1-3/8	3.00
10	215T	1-3/8	3.80
15	254T	1-5/8	4.40
20	256T	1-5/8	4.40
25	284T	1-7/8	4.40
30	286T	1-7/8	5.20
40	324T	2-1/8	6.00
50	326T	2-1/8	6.80
60	364T	2-3/8	7.40
75	365T	2-3/8	8.60
100	+405T	2-7/8	8.60
125	+444T	3-3/8	10.50
150	+445T	3-3/8	10.50
200	+447T	3-3/8	13.20

+ Energy Efficient (TEFC-XE) Frame

TABLE 20 - MINIMUM SHEAVE DIAMETERS FOR DODGE TORQUE-ARM REDUCERS

TXT, SCXT Reducer	Single Reduction		Double Reduction			
	Shaft Diameter	5:1	Shaft Diameter	9:1	15:1	25:1
1	1-1/8	4.00	3/4	4.0	3.0	3.0
2	1-7/16	3.00	1-1/8	5.0	3.0	3.0
3	1-5/8	7.00	1-1/4	5.0	4.0	4.0
4	1-15/16	7.50	1-7/16	6.5	4.6	4.6
5	2-3/16	9.50	1-15/16	7.0	5.4	5.4
6	2-3/16	6.50	2-3/16	7.0	6.2	6.2
7	2-7/16	7.50	2-7/16	7.0	6.2	6.2
8	2-7/16	9.20	2-7/16		6.2	6.2
9	2-7/16	9.50	2-7/16		8.0	8.0
10			2-11/16		8.5	8.5
12			2-11/16		9.5	9.5
13			2-15/16			12.0
14			2-15/16			15.0
15			3-7/16			20.0

FEATURES/BENEFITS PAGE G2-3	NOMENCLATURE PAGE G2-11	SELECTION/DIMENSIONS PAGE G2-144	RELATED PRODUCTS PAGE G2-152
--------------------------------	----------------------------	-------------------------------------	---------------------------------

RELATED PRODUCTS



TORQUE-ARM Shaft Mount Speed Reducers

TABLE 21 - NOMINAL SHEAVE RATIOS REQUIRED FOR DODGE TORQUE-ARM REDUCERS

Reducer Output RPM	5:1 Nominal Reducer Ratio			Reducer Output RPM	9:1 Nominal Reducer Ratio			Reducer Output RPM	15:1 Nominal Reducer Ratio			Reducer Output RPM	25:1 Nominal Reducer Ratio		
	Motor Speed				Motor Speed				Motor Speed				Motor Speed		
	1750	1450	1170		1750	1450	1170		1750	1450	1170		1750	1450	1170
400.00	1.14	1.38	1.71	200.00	1.03	1.24	1.54	120.00	1.03	1.24	1.54	76.00	1.09	1.31	1.62
395.00	1.13	1.36	1.69	198.00	1.02	1.23	1.52	118.00	1.01	1.22	1.51	74.00	1.06	1.28	1.58
390.00	1.11	1.34	1.67	196.00	1.01	1.22	1.51	116.00	1.01	1.20	1.49	72.00	1.03	1.24	1.54
385.00	1.10	1.33	1.65	194.00	1.00	1.20	1.49	114.00	1.02	1.18	1.46	70.00	1.00	1.21	1.50
380.00	1.09	1.31	1.62	192.00	1.01	1.19	1.48	112.00	1.04	1.16	1.44	68.00	1.03	1.17	1.45
375.00	1.07	1.29	1.60	190.00	1.02	1.18	1.46	110.00	1.06	1.14	1.41	66.00	1.06	1.14	1.41
370.00	1.06	1.28	1.58	188.00	1.03	1.17	1.45	108.00	1.08	1.12	1.38	64.00	1.09	1.10	1.37
365.00	1.04	1.26	1.56	186.00	1.05	1.15	1.43	106.00	1.10	1.10	1.36	62.00	1.13	1.07	1.32
360.00	1.03	1.24	1.54	184.00	1.06	1.14	1.42	104.00	1.12	1.08	1.33	60.00	1.17	1.03	1.28
355.00	1.01	1.22	1.52	182.00	1.07	1.13	1.40	102.00	1.14	1.06	1.31	58.00	1.21	1.00	1.24
350.00	1.00	1.21	1.50	180.00	1.08	1.12	1.38	100.00	1.17	1.03	1.28	56.00	1.25	1.04	1.20
345.00	1.01	1.19	1.47	178.00	1.09	1.10	1.37	98.00	1.19	1.01	1.26	54.00	1.30	1.07	1.15
340.00	1.03	1.17	1.45	176.00	1.10	1.09	1.35	96.00	1.22	1.01	1.23	52.00	1.35	1.12	1.11
335.00	1.04	1.16	1.43	174.00	1.12	1.08	1.34	94.00	1.24	1.03	1.21	50.00	1.40	1.16	1.07
330.00	1.06	1.14	1.41	172.00	1.13	1.07	1.32	92.00	1.27	1.05	1.18	48.00	1.46	1.21	1.03
325.00	1.08	1.12	1.39	170.00	1.14	1.06	1.31	90.00	1.30	1.07	1.15	46.00	1.52	1.26	1.02
320.00	1.09	1.10	1.37	168.00	1.16	1.04	1.29	88.00	1.33	1.10	1.13	44.00	1.59	1.32	1.06
315.00	1.11	1.09	1.35	166.00	1.17	1.03	1.28	86.00	1.36	1.12	1.10	42.00	1.67	1.38	1.11
310.00	1.13	1.07	1.32	164.00	1.19	1.02	1.26	84.00	1.39	1.15	1.08	40.00	1.75	1.45	1.17
305.00	1.15	1.05	1.30	162.00	1.20	1.01	1.25	82.00	1.42	1.18	1.05	38.00	1.84	1.53	1.23
300.00	1.17	1.03	1.28	160.00	1.22	1.01	1.23	80.00	1.46	1.21	1.03	36.00	1.94	1.61	1.30
295.00	1.19	1.02	1.26	158.00	1.23	1.02	1.22	78.00	1.50	1.24	1.00	34.00	2.06	1.71	1.38
290.00	1.21	1.00	1.24	156.00	1.25	1.03	1.20	76.00	1.54	1.27	1.03	32.00	2.19	1.81	1.46
285.00	1.23	1.02	1.22	154.00	1.26	1.05	1.18	74.00	1.58	1.31	1.05	30.00	2.33	1.93	1.56
280.00	1.25	1.04	1.20	152.00	1.28	1.06	1.17	72.00	1.62	1.34	1.08	28.00	2.50	2.07	1.67
275.00	1.27	1.05	1.18	150.00	1.30	1.07	1.15	70.00	1.67	1.38	1.11	26.00	2.69	2.23	1.80
270.00	1.30	1.07	1.15	148.00	1.31	1.09	1.14	68.00	1.72	1.42	1.15	24.00	2.92	2.42	1.95
265.00	1.32	1.09	1.13	146.00	1.33	1.10	1.12	66.00	1.77	1.46	1.18	22.00	3.18	2.64	2.13
260.00	1.35	1.12	1.11	144.00	1.35	1.12	1.11	64.00	1.82	1.51	1.22	20.00	3.50	2.90	2.34
255.00	1.37	1.14	1.09	142.00	1.37	1.13	1.09	62.00	1.88	1.56	1.26	18.00	3.89	3.22	2.60
250.00	1.40	1.16	1.07	140.00	1.39	1.15	1.08	60.00	1.94	1.61	1.30	16.00	4.38	3.63	2.93
245.00	1.43	1.18	1.05	138.00	1.41	1.17	1.06	58.00	2.01	1.67	1.34	14.00	5.00	4.14	3.34
240.00	1.46	1.21	1.03	136.00	1.43	1.18	1.05	56.00	2.08	1.73	1.39	12.00	5.83	4.83	3.90
235.00	1.49	1.23	1.00	134.00	1.45	1.20	1.03	54.00	2.16	1.79	1.44	10.00	7.00	5.80	4.68
230.00	1.52	1.26	1.02	132.00	1.47	1.22	1.02	52.00	2.24	1.86	1.50	8.00	8.75	7.25	5.85
225.00	1.56	1.29	1.04	130.00	1.50	1.24	1.00	50.00	2.33	1.93	1.56	6.00	11.67	9.67	7.80
220.00	1.59	1.32	1.06	128.00	1.52	1.26	1.02	48.00	2.43	2.01	1.63				
215.00	1.63	1.35	1.09	126.00	1.54	1.28	1.03	46.00	2.54	2.10	1.70				
210.00	1.67	1.38	1.11	124.00	1.57	1.30	1.05	44.00	2.65	2.20	1.77				
205.00	1.71	1.41	1.14	122.00	1.59	1.32	1.07	42.00	2.78	2.30	1.86				
200.00	1.75	1.45	1.17	120.00	1.62	1.34	1.08	40.00	2.92	2.42	1.95				

Speed Increase Ratios are shown in bold type

FEATURES/BENEFITS PAGE G2-3	NOMENCLATURE PAGE G2-11	SELECTION/DIMENSIONS PAGE G2-144	RELATED PRODUCTS PAGE G2-152
--------------------------------	----------------------------	-------------------------------------	---------------------------------

RELATED PRODUCTS



TORQUE-ARM Shaft Mount Speed Reducers

TABLE 21 - NOMINAL SHEAVE RATIOS REQUIRED FOR DODGE TORQUE-ARM REDUCERS (con't)

Reducer Output RPM	5:1 Nominal Reducer Ratio			Reducer Output RPM	9:1 Nominal Reducer Ratio			Reducer Output RPM	15:1 Nominal Reducer Ratio			Reducer Output RPM	25:1 Nominal Reducer Ratio		
	Motor Speed				Motor Speed				Motor Speed				Motor Speed		
	1750	1450	1170		1750	1450	1170		1750	1450	1170		1750	1450	1170
195.00	1.79	1.49	1.20	118.00	1.65	1.37	1.10	38.00	3.07	2.54	2.05				
190.00	1.84	1.53	1.23	116.00	1.68	1.39	1.12	36.00	3.24	2.69	2.17				
185.00	1.89	1.57	1.26	114.00	1.71	1.41	1.14	34.00	3.43	2.84	2.29				
180.00	1.94	1.61	1.30	112.00	1.74	1.44	1.16	32.00	3.65	3.02	2.44				
175.00	2.00	1.66	1.34	110.00	1.77	1.46	1.18	30.00	3.89	3.22	2.60				
170.00	2.06	1.71	1.38	108.00	1.80	1.49	1.20	28.00	4.17	3.45	2.79				
165.00	2.12	1.76	1.42	106.00	1.83	1.52	1.23	26.00	4.49	3.72	3.00				
160.00	2.19	1.81	1.46	104.00	1.87	1.55	1.25	24.00	4.86	4.03	3.25				
155.00	2.26	1.87	1.51	102.00	1.91	1.58	1.27	22.00	5.30	4.39	3.55				
150.00	2.33	1.93	1.56	100.00	1.94	1.61	1.30	20.00	5.83	4.83	3.90				
145.00	2.41	2.00	1.61					18.00	6.48	5.37	4.33				
140.00	2.50	2.07	1.67					16.00	7.29	6.04	4.88				
135.00	2.59	2.15	1.73					14.00	8.33	6.90	5.57				
130.00	2.69	2.23	1.80					12.00	9.72	8.06	6.50				
125.00	2.80	2.32	1.87					10.00	11.67	9.67	7.80				
120.00	2.92	2.42	1.95												
115.00	3.04	2.52	2.03												
110.00	3.18	2.64	2.13												
105.00	3.33	2.76	2.23												
100.00	3.50	2.90	2.34												

Speed Increase Ratios are shown in bold type

Gearing Reference Guide

TORQUE-ARM II

TORQUE-ARM

MAXUM Concentric Reducer

TIGEAR-2

FEATURES/BENEFITS PAGE G2-3	NOMENCLATURE PAGE G2-11	SELECTION/DIMENSIONS PAGE G2-144	RELATED PRODUCTS PAGE G2-152
--------------------------------	----------------------------	-------------------------------------	---------------------------------



RELATED PRODUCTS

TORQUE-ARM Shaft Mount Speed Reducers

TABLE 22 - NOMINAL SHEAVE SPEED (RPM) AT INPUT FOR DODGE REDUCERS 1750 RPM MOTOR

Reducer Output RPM	5:1 Nominal Reducer Ratio	Reducer Output RPM	9:1 Nominal Reducer Ratio	Reducer Output RPM	15:1 Nominal Reducer Ratio	Reducer Output RPM	25:1 Nominal Reducer Ratio
400.00	2000	200.00	1800	120.00	1800	76.00	1900
395.00	1975	198.00	1782	118.00	1770	74.00	1850
390.00	1950	196.00	1764	116.00	1740	72.00	1800
385.00	1925	194.00	1746	114.00	1710	70.00	1750
380.00	1900	192.00	1728	112.00	1680	68.00	1700
375.00	1875	190.00	1710	110.00	1650	66.00	1650
370.00	1850	188.00	1692	108.00	1620	64.00	1600
365.00	1825	186.00	1674	106.00	1590	62.00	1550
360.00	1800	184.00	1656	104.00	1560	60.00	1500
355.00	1775	182.00	1638	102.00	1530	58.00	1450
350.00	1750	180.00	1620	100.00	1500	56.00	1400
345.00	1725	178.00	1602	98.00	1470	54.00	1350
340.00	1700	176.00	1584	96.00	1440	52.00	1300
335.00	1675	174.00	1566	94.00	1410	50.00	1250
330.00	1650	172.00	1548	92.00	1380	48.00	1200
325.00	1625	170.00	1530	90.00	1350	46.00	1150
320.00	1600	168.00	1512	88.00	1320	44.00	1100
315.00	1575	166.00	1494	86.00	1290	42.00	1050
310.00	1550	164.00	1476	84.00	1260	40.00	1000
305.00	1525	162.00	1458	82.00	1230	38.00	950
300.00	1500	160.00	1440	80.00	1200	36.00	900
295.00	1475	158.00	1422	78.00	1170	34.00	850
290.00	1450	156.00	1404	76.00	1140	32.00	800
285.00	1425	154.00	1386	74.00	1110	30.00	750
280.00	1400	152.00	1368	72.00	1080	28.00	700
275.00	1375	150.00	1350	70.00	1050	26.00	650
270.00	1350	148.00	1332	68.00	1020	24.00	600
265.00	1325	146.00	1314	66.00	990	22.00	550
260.00	1300	144.00	1296	64.00	960	20.00	500
255.00	1275	142.00	1278	62.00	930	18.00	450
250.00	1250	140.00	1260	60.00	900	16.00	400
245.00	1225	138.00	1242	58.00	870	14.00	350
240.00	1200	136.00	1224	56.00	840	12.00	300
235.00	1175	134.00	1206	54.00	810	10.00	250
230.00	1150	132.00	1188	52.00	780	8.00	200
225.00	1125	130.00	1170	50.00	750	6.00	150
220.00	1100	128.00	1152	48.00	720		
215.00	1075	126.00	1134	46.00	690		
210.00	1050	124.00	1116	44.00	660		
205.00	1025	122.00	1098	42.00	630		
200.00	1000	120.00	1080	40.00	600		

RELATED PRODUCTS



TORQUE-ARM Shaft Mount Speed Reducers

TABLE 22 - NOMINAL SHEAVE SPEED (RPM) AT INPUT FOR DODGE REDUCERS 1750 RPM MOTOR
(con't)

Reducer Output RPM	5:1 Nominal Reducer Ratio	Reducer Output RPM	9:1 Nominal Reducer Ratio	Reducer Output RPM	15:1 Nominal Reducer Ratio	Reducer Output RPM	25:1 Nominal Reducer Ratio
195.00	975	118.00	1062	38.00	570		
190.00	950	116.00	1044	36.00	540		
185.00	925	114.00	1026	34.00	510		
180.00	900	112.00	1008	32.00	480		
175.00	875	110.00	990	30.00	450		
170.00	850	108.00	972	28.00	420		
165.00	825	106.00	954	26.00	390		
160.00	800	104.00	936	24.00	360		
155.00	775	102.00	918	22.00	330		
150.00	750	100.00	900	20.00	300		
145.00	725			18.00	270		
140.00	700			16.00	240		
135.00	675			14.00	210		
130.00	650			12.00	180		
125.00	625			10.00	150		
120.00	600						
115.00	575						
110.00	550						
105.00	525						
100.00	500						

Gearing Reference Guide

TORQUE-ARM II

TORQUE-ARM

MAXIMUM Concentric Reducer

TIGEAR-2

FEATURES/BENEFITS PAGE G2-3	NOMENCLATURE PAGE G2-11	SELECTION/DIMENSIONS PAGE G2-144	RELATED PRODUCTS PAGE G2-152
--------------------------------	----------------------------	-------------------------------------	---------------------------------

RELATED PRODUCTS



TORQUE-ARM Shaft Mount Speed Reducers V-BELT DRIVES FOR TXT115, 125 & SCXT115, 125 REDUCERS 3VX, 5VX, 8VX, AX, BX, CX AND DX BELTS REQUIRED

These are typical drives for average service conditions, For other conditions, output speeds or motor speeds see reducer specification for minimum driven sheave diameter and use V-belt selection tables

Size 115 Driven by 1750 RPM Motors									Size 125 Driven by 1750 RPM Motors										
Out put RPM	V-belt Drive Ratio	Sheave Diameters *		Qty & Belt Size	Out put RPM	V-belt Drive Ratio	Sheave Diameters *		Qty & Belt Size	Out put RPM	V-belt Drive Ratio	Sheave Diameters *		Qty & Belt Size	Out put RPM	V-belt Drive Ratio	Sheave Diameters *		Qty & Belt Size
		Driver	Driven				Driver	Driven				Driver	Driven				Driver	Driven	
19	6.00	3.00	18.00	2-A	73	1.56	3.20	5.00	3-A	16	4.23	3.35	14.00	2-3V	49	1.40	3.00	4.20	2-A
20	5.63	3.20	18.00	2-A	74	1.55	4.00	6.20	2-A	16	4.17	3.60	15.00	2-A	50	1.38	3.65	5.00	2-3V
22	5.07	2.80	14.00	2-3V	75	1.52	3.15	4.75	3-3V	17	4.06	2.65	10.60	2-3V	50	1.37	3.20	4.40	2-A
22	5.29	3.40	18.00	2-A	76	1.51	3.00	4.50	3-3V	17	4.00	3.00	12.00	2-A	51	1.35	3.35	4.50	2-3V
24	4.73	3.00	14.00	2-3V	76	1.50	4.00	6.00	2-A	18	3.84	2.80	10.60	2-3V	51	1.33	3.60	4.80	2-A
24	4.69	3.20	15.00	2-A	77	1.48	4.20	6.20	2-A	18	3.75	3.20	12.00	2-A	52	1.31	3.65	4.75	2-3V
25	4.50	4.00	18.00	2-A	78	1.46	3.65	5.30	2-3V	19	3.58	3.00	10.60	2-3V	52	1.32	4.40	5.80	2-A
27	4.23	3.35	14.00	2-3V	79	1.45	4.50	6.50	2-3V	19	3.53	3.00	10.60	2-A	53	1.29	4.12	5.30	2-3V
27	4.17	3.60	15.00	2-A	79	1.45	4.00	5.80	2-A	20	3.40	3.15	10.60	2-3V	53	1.30	4.00	5.20	2-A
29	3.88	3.65	14.00	2-3V	80	1.43	4.20	6.00	2-A	20	3.33	3.60	12.00	2-A	54	1.27	4.75	6.00	2-3V
29	3.95	3.80	15.00	2-A	82	1.38	2.65	3.65	3-3V	21	3.20	3.35	10.60	2-3V	54	1.27	4.40	5.60	2-A
30	3.75	3.20	12.00	2-A	82	1.39	4.60	6.40	2-B	21	3.31	3.20	10.60	2-A	55	1.24	3.65	4.50	2-3V
31	3.68	5.00	18.40	2-B	83	1.38	4.20	5.80	2-A	22	3.06	2.65	8.00	2-3V	55	1.25	4.00	5.00	2-A
32	3.58	3.00	10.60	2-3V	84	1.36	4.12	5.60	2-3V	22	3.12	3.40	10.60	2-A	56	1.22	4.12	5.00	2-3V
32	3.53	3.00	10.60	2-A	85	1.34	4.50	6.00	2-3V	23	2.93	3.65	10.60	2-3V	56	1.23	4.40	5.40	2-A
34	3.31	3.20	10.60	2-A	85	1.33	4.20	5.60	2-A	23	3.00	3.00	9.00	2-A	57	1.20	5.00	6.00	2-3V
35	3.26	4.60	15.00	2-A	86	1.32	4.40	5.80	2-A	24	2.89	2.80	8.00	2-3V	57	1.20	4.00	4.80	2-A
36	3.20	3.35	10.60	2-3V	87	1.31	3.65	4.75	2-3V	24	2.81	3.20	9.00	2-A	58	1.18	4.50	5.30	2-3V
36	3.16	3.80	12.00	2-A	88	1.29	4.12	5.30	2-3V	25	2.69	3.00	8.00	2-3V	58	1.18	4.40	5.20	2-A
38	2.97	4.75	14.00	2-3V	88	1.30	4.00	5.20	2-A	25	2.73	3.00	8.20	2-A	59	1.15	4.12	4.75	2-3V
38	3.00	4.00	12.00	2-A	91	1.25	4.50	5.60	2-3V	26	2.63	2.65	6.90	2-3V	59	1.15	4.00	4.60	2-A
40	2.82	5.00	14.00	2-3V	91	1.25	4.00	5.00	2-A	26	2.65	3.40	9.00	2-A	60	1.13	5.30	6.00	2-3V
40	2.86	4.20	12.00	2-A	92	1.24	3.65	4.50	2-3V	27	2.49	2.80	6.90	2-3V	60	1.14	4.20	4.80	2-A
42	2.69	3.00	8.00	2-3V	92	1.24	4.20	5.20	2-A	27	2.56	3.20	8.20	2-A	61	1.11	4.50	5.00	2-3V
42	2.73	4.40	12.00	2-A	94	1.22	4.12	5.00	3-3V	28	2.48	2.65	6.50	2-3V	61	1.13	4.80	5.40	2-B
43	2.63	2.65	6.90	3-3V	94	1.21	4.80	5.80	2-B	28	2.41	3.40	8.20	2-A	62	1.09	4.12	4.50	2-3V
44	2.56	3.15	8.00	2-3V	97	1.18	4.50	5.30	3-3V	29	2.35	2.80	6.50	2-3V	62	1.10	4.00	4.40	2-A
44	2.56	3.20	8.20	2-A	97	1.18	5.60	6.60	2-B	29	2.33	3.00	7.00	2-A	63	1.09	3.35	3.65	3-3V
45	2.51	5.60	14.00	2-3V	98	1.17	4.80	5.60	2-B	30	2.29	2.65	6.00	2-3V	63	1.09	4.40	4.80	2-A
45	2.52	4.20	10.60	2-A	99	1.15	6.00	6.90	2-3V	30	2.28	3.60	8.20	2-A	64	1.06	5.00	5.30	2-3V
46	2.48	2.65	6.50	3-3V	101	1.13	5.30	6.00	2-3V	31	2.19	3.00	6.50	2-3V	64	1.07	5.40	5.80	2-B
46	2.50	3.60	9.00	2-A	101	1.13	4.80	5.40	2-B	31	2.19	3.20	7.00	2-A	65	1.06	4.50	4.75	2-3V
47	2.41	3.40	8.20	2-A	102	1.12	5.00	5.60	2-B	32	2.13	2.65	5.60	2-3V	65	1.05	4.00	4.20	2-A
48	2.37	4.50	10.60	2-3V	104	1.09	4.12	4.50	3-3V	32	2.13	3.00	6.40	2-A	68	1.00	4.12	4.12	2-3V
49	2.32	3.00	6.90	2-3V	104	1.10	6.00	6.60	2-B	33	2.08	3.15	6.50	2-3V	68	1.00	4.00	4.00	2-A
49	2.30	4.60	10.60	2-A	105	1.08	4.80	5.20	2-B	33	2.06	3.40	7.00	2-A	72	0.95	4.75	4.50	2-3V

Note: These V-belts drives are designed for average service and are based on reducer ratings. Where fire hazards are prevalent and fire prevention laws apply, it is recommended that drives be redesigned using a service factor of 2.0 on the hp rating of the motor - refer to V-belt drive tables or consult DODGE

* DODGE stock sheaves, outside diameters shown for DYNA-V (3V); pitch diameters for A & B sheaves. All ratios based on P.D. Sheaves in shaded area represent speed up drives.

FEATURES/BENEFITS PAGE G2-3	NOMENCLATURE PAGE G2-11	SELECTION/DIMENSIONS PAGE G2-144	RELATED PRODUCTS PAGE G2-152
--------------------------------	----------------------------	-------------------------------------	---------------------------------

RELATED PRODUCTS



TORQUE-ARM Shaft Mount Speed Reducers V-BELT DRIVES FOR TXT115, 125 & SCXT115, 125 REDUCERS 3VX, 5VX, 8VX, AX, BX, CX AND DX BELTS REQUIRED (con't)

These are typical drives for average service conditions. For other conditions, output speeds or motor speeds see reducer specification for minimum driven sheave diameter and use V-belt selection tables

Size 115 Driven by 1750 RPM Motors										Size 125 Driven by 1750 RPM Motors									
Out put RPM	V-belt Drive Ratio	Sheave Diameters *		Qty & Belt Size	Out put RPM	V-belt Drive Ratio	Sheave Diameters *		Qty & Belt Size	Out put RPM	V-belt Drive Ratio	Sheave Diameters *		Qty & Belt Size	Out put RPM	V-belt Drive Ratio	Sheave Diameters *		Qty & Belt Size
		Driver	Driven				Driver	Driven				Driver	Driven				Driver	Driven	
19	6.00	3.00	18.00	2-A	73	1.56	3.20	5.00	3-A	16	4.23	3.35	14.00	2-3V	49	1.40	3.00	4.20	2-A
50	2.28	3.60	8.20	2-A	106	1.07	5.60	6.00	2-3V	34	2.02	3.00	6.00	2-3V	72	0.95	4.20	4.00	2-A
51	2.24	4.75	10.60	2-3V	107	1.06	5.00	5.30	2-3V	34	2.00	3.20	6.40	2-A	73	0.93	6.00	5.60	2-3V
51	2.25	4.00	9.00	2-A	107	1.07	5.80	6.20	2-B	35	1.95	3.35	6.50	2-3V	73	0.93	5.80	5.40	2-B
52	2.21	3.65	8.00	2-3V	110	1.04	5.00	5.20	2-B	35	1.94	3.20	6.20	2-A	74	0.92	3.65	3.35	3-3V
52	2.21	4.80	10.60	2-A	111	1.03	6.40	6.60	2-B	36	1.88	3.00	5.60	2-3V	74	0.92	4.80	4.40	2-A
53	2.14	4.20	9.00	2-A	117	0.97	6.80	6.60	2-B	36	1.88	3.20	6.00	2-A	75	0.91	4.50	4.12	2-3V
55	2.08	3.15	6.50	3-3V	118	0.96	5.40	5.20	2-B	38	1.78	3.00	5.30	2-3V	75	0.90	4.20	3.80	2-A
55	2.07	3.00	6.20	3-A	120	0.95	5.60	5.30	2-3V	38	1.81	3.20	5.80	2-A	76	0.90	5.00	4.50	2-3V
56	2.05	4.00	8.20	2-A	120	0.95	3.80	3.60	3-A	39	1.75	8.00	14.00	2-3V	76	0.89	5.60	5.00	2-B
57	2.02	3.00	6.00	3-3V	122	0.93	6.00	5.60	2-3V	39	1.75	3.20	5.60	2-A	77	0.88	4.12	3.65	2-3V
58	1.95	4.12	8.00	2-3V	122	0.93	5.80	5.40	2-B	40	1.69	3.15	5.30	2-3V	77	0.88	5.20	4.60	2-B
58	1.95	4.20	8.20	2-A	124	0.92	3.65	3.35	3-3V	40	1.69	3.20	5.40	2-A	79	0.87	4.75	4.12	2-3V
59	1.93	3.00	5.80	3-A	124	0.92	7.40	6.80	2-B	41	1.68	3.00	5.00	2-3V	79	0.86	4.40	3.80	2-A
60	1.90	3.65	6.90	2-3V	125	0.91	6.60	6.00	2-B	41	1.65	3.40	5.60	2-A	81	0.85	5.30	4.50	2-3V
61	1.88	3.00	5.60	3-3V	127	0.90	5.30	4.75	2-3V	42	1.62	2.80	4.50	3-3V	81	0.84	5.00	4.20	2-A
61	1.86	4.40	8.20	2-A	127	0.90	5.80	5.20	2-B	42	1.63	3.20	5.20	2-A	82	0.83	6.00	5.00	2-3V
62	1.83	5.80	10.60	2-A	129	0.88	6.00	5.30	2-3V	43	1.59	3.00	4.75	2-3V	82	0.83	4.80	4.00	2-A
63	1.81	2.65	4.75	3-3V	129	0.88	5.20	4.60	2-B	43	1.59	3.40	5.40	2-A	83	0.82	5.00	4.12	2-3V
64	1.79	3.65	6.50	2-3V	131	0.87	6.90	6.00	2-3V	44	1.54	3.65	5.60	2-3V	83	0.82	4.40	3.60	2-A
64	1.78	4.60	8.20	2-A	132	0.86	6.50	5.60	2-3V	44	1.56	3.20	5.00	2-A	84	0.81	4.50	3.65	2-3V
67	1.71	2.65	4.50	3-3V	132	0.86	5.80	5.00	2-B	45	1.51	3.00	4.50	2-3V	84	0.81	5.40	4.40	2-A
67	1.71	4.80	8.20	2-A	134	0.85	5.30	4.50	3-3V	45	1.53	3.00	4.60	2-A	85	0.80	5.60	4.50	2-3V
68	1.67	4.20	7.00	2-A	134	0.85	5.40	4.60	2-B	46	1.50	3.35	5.00	2-3V	85	0.80	5.00	4.00	2-A
69	1.65	3.65	6.00	2-3V	135	0.84	6.40	5.40	2-B	46	1.50	3.20	4.80	2-A					
70	1.62	2.80	4.50	3-3V	136	0.84	6.20	5.20	2-B	47	1.46	3.65	5.30	2-3V					
70	1.64	5.00	8.20	2-A	137	0.83	6.00	5.00	2-3V	47	1.47	3.00	4.40	2-A					
71	1.60	4.00	6.40	2-A	137	0.83	6.00	5.00	2-B	48	1.44	3.15	4.50	2-3V					
72	1.58	4.12	6.50	2-3V	139	0.82	5.00	4.12	3-3V	48	1.41	3.40	4.80	2-A					
73	1.57	2.65	4.12	3-3V	139	0.82	5.60	4.60	2-B	49	1.38	3.00	4.12	2-3V					

Note: These V-belts drives are designed for average service and are based on reducer ratings. Where fire hazards are prevalent and fire prevention laws apply, it is recommended that drives be redesigned using a service factor of 2.0 on the hp rating of the motor - refer to V-belt drive tables or consult DODGE

* DODGE stock sheaves, outside diameters shown for DYNA-V (3V); pitch diameters for A & B sheaves. All ratios based on P.D. Sheaves in shaded area represent speed up drives.

FEATURES/BENEFITS PAGE G2-3	NOMENCLATURE PAGE G2-11	SELECTION/DIMENSIONS PAGE G2-144	RELATED PRODUCTS PAGE G2-152
--------------------------------	----------------------------	-------------------------------------	---------------------------------

RELATED PRODUCTS



TORQUE-ARM Shaft Mount Speed Reducers V-BELT DRIVES FOR TXT215, TXT225 & SCXT215, SCXT225 REDUCERS 3VX, 5VX, 8VX, AX, BX, CX AND DX BELTS REQUIRED

These are typical drives for average service conditions, For other conditions. output speeds or motor speeds see reducer specification for minimum driven sheave diameter and use V-belt selection tables

Size 115 Driven by 1750 RPM Motors									Size 125 Driven by 1750 RPM Motors										
Out-put RPM	V-belt Drive Ratio	Sheave Diameters *		Qty & Belt Size	Out-put RPM	V-belt Drive Ratio	Sheave Diameters *		Qty & Belt Size	Out-put RPM	V-belt Drive Ratio	Sheave Diameters *		Qty & Belt Size	Out-put RPM	V-belt Drive Ratio	Sheave Diameters *		Qty & Belt Size
		Driver	Driven				Driver	Driven				Driver	Driven				Driver	Driven	
17	7.29	2.65	19.00	2-3V	76	1.63	1.80	6.20	4-A	10	7.29	2.65	19.00	2-3V	48	1.54	4.80	7.40	2-B
19	6.42	3.00	19.00	2-3V	77	1.61	5.00	8.00	3-3V	12	6.42	3.00	19.00	2-3V	49	1.51	5.30	8.00	2-3V
21	6.00	3.00	18.00	3-A	77	1.62	6.80	11.00	2-B	12	6.00	3.00	18.00	2-A	49	1.54	5.60	8.60	2-B
22	5.74	3.35	19.00	2-3V	79	1.57	6.00	9.40	2-B	14	5.37	2.65	14.00	2-3V	50	1.50	3.35	5.00	3-3V
22	5.63	3.20	18.00	2-A	81	1.54	4.50	6.90	3-3V	14	5.29	3.40	18.00	2-A	50	1.48	5.00	7.40	2-B
23	5.37	2.65	14.00	3-3V	81	1.53	3.80	5.80	4-A	15	5.07	2.80	14.00	2-3V	51	1.46	3.65	5.30	3-3V
23	5.29	3.40	18.00	2-A	83	1.50	3.35	5.00	4-3V	15	5.00	3.00	15.00	2-A	51	1.46	5.60	8.20	2-A
25	5.00	3.60	18.00	2-A	83	1.50	3.60	5.40	4-A	16	4.73	3.00	14.00	2-3V	52	1.42	3.35	4.75	3-3V
26	4.73	3.00	14.00	2-3V	84	1.47	3.40	5.00	4-A	16	4.69	3.20	15.00	2-A	52	1.42	5.20	7.40	2-B
26	4.69	3.20	15.00	2-A	85	1.46	4.12	6.00	3-3V	17	4.50	3.15	14.00	2-3V	53	1.42	4.80	6.80	2-B
29	4.26	4.50	19.00	2-3V	85	1.47	6.40	9.40	2-B	17	4.41	3.40	15.00	2-A	54	1.38	5.00	6.90	2-3V
29	4.29	4.20	18.00	2-A	87	1.42	3.35	4.75	4-3V	18	4.23	3.35	14.00	2-3V	54	1.38	4.80	6.60	2-B
30	4.09	4.40	18.00	2-A	87	1.43	6.00	8.60	2-B	18	4.17	3.60	15.00	2-A	56	1.34	6.00	8.00	2-3V
31	4.06	2.65	10.60	3-3V	88	1.41	3.40	4.80	4-A	19	3.88	3.65	14.00	2-3V	56	1.33	4.80	6.40	2-B
31	4.00	3.00	12.00	3-A	89	1.39	4.60	6.40	3-A	19	3.95	3.80	15.00	2-A	57	1.30	5.00	6.50	2-3V
33	3.75	3.20	12.00	3-A	90	1.37	4.75	6.50	3-3V	20	3.75	3.20	12.00	2-A	57	1.32	5.00	6.60	2-B
34	3.61	5.30	19.00	2-3V	90	1.39	6.20	8.60	2-B	22	3.40	3.15	10.60	2-3V	58	1.29	4.12	5.30	3-3V
34	3.60	5.00	18.00	2-A	92	1.35	3.35	4.50	4-3V	22	3.33	3.60	12.00	2-A	58	1.29	4.80	6.20	2-B
35	3.58	3.00	10.60	3-3V	92	1.34	6.40	8.60	2-B	23	3.20	3.35	10.60	2-3V	59	1.27	4.75	6.00	3-3V
35	3.53	3.00	10.60	3-A	93	1.34	4.50	6.00	3-3V	23	3.31	3.20	10.60	2-A	59	1.27	5.20	6.60	2-B
37	3.31	3.20	10.60	3-A	93	1.33	3.60	4.80	4-A	24	3.06	2.65	8.00	3-3V	60	1.23	5.60	6.90	2-3V
38	3.26	4.60	15.00	2-A	94	1.33	8.00	10.60	2-3V	24	3.12	3.40	10.60	2-A	60	1.25	4.80	6.00	2-B
39	3.20	3.35	10.60	3-3V	94	1.32	3.80	5.00	4-A	25	2.93	3.65	10.60	2-3V	61	1.23	5.30	6.50	2-3V
39	3.21	4.80	15.40	2-B	96	1.29	4.12	5.30	3-3V	25	2.94	3.60	10.60	2-A	61	1.23	5.20	6.40	2-B
40	3.13	4.50	14.00	2-3V	96	1.29	4.80	6.20	3-A	26	2.89	2.80	8.00	3-3V	62	1.20	5.00	6.00	2-3V
40	3.12	3.40	10.60	3-A	97	1.28	3.60	4.60	4-A	26	2.86	4.20	12.00	2-A	62	1.21	4.80	5.80	2-B
41	3.06	2.65	8.00	3-3V	99	1.25	4.80	6.00	3-A	27	2.77	6.90	19.00	2-3V	64	1.16	5.60	6.50	2-3V
41	3.00	4.00	12.00	2-A	101	1.23	6.50	8.00	2-3V	27	2.73	4.40	12.00	2-A	64	1.17	4.80	5.60	2-B
43	2.89	2.80	8.00	3-3V	101	1.23	6.00	7.40	2-B	28	2.63	2.65	6.90	3-3V	65	1.15	6.00	6.90	2-3V
43	2.86	4.20	12.00	2-A	102	1.22	4.12	5.00	3-3V	28	2.65	4.00	10.60	2-A	65	1.15	5.20	6.00	2-B
45	2.77	6.90	19.00	2-3V	102	1.22	4.60	5.60	3-A	29	2.56	3.15	8.00	3-3V	66	1.13	5.30	6.00	2-3V
45	2.73	3.00	8.20	3-A	103	1.20	5.00	6.00	3-3V	29	2.61	4.60	12.00	2-A	66	1.13	4.80	5.40	2-B
46	2.69	3.00	8.00	3-3V	103	1.21	3.80	4.60	3A	30	2.48	2.65	6.50	3-3V	67	1.12	5.00	5.60	2-3V
46	2.73	4.40	12.00	2-A	104	1.19	5.20	6.20	3-B	30	2.52	4.20	10.60	2-A	67	1.12	5.00	5.60	2-B
48	2.56	3.15	8.00	4-3V	105	1.18	4.50	5.30	4-3V	31	2.41	3.35	8.00	3-3V	68	1.09	4.12	4.50	3-3V
48	2.58	4.80	12.40	2-B	105	1.19	5.40	6.40	3-B	31	2.41	4.40	10.60	2-A	68	1.10	5.80	6.40	2-B

Note: These V-belts drives are designed for average service and are based on reducer ratings. Where fire hazards are prevalent and fire prevention laws apply, it is recommended that drives be redesigned using a service factor of 2.0 on the hp rating of the motor - refer to V-belt drive tables or consult DODGE

* DODGE stock sheaves. outside diameters shown for DYNA-V (3V); pitch diameters for A & B sheaves. All ratios based on P.D. Sheaves in shaded area represent speed up drives.

FEATURES/BENEFITS PAGE G2-3	NOMENCLATURE PAGE G2-11	SELECTION/DIMENSIONS PAGE G2-144	RELATED PRODUCTS PAGE G2-152
--------------------------------	----------------------------	-------------------------------------	---------------------------------

RELATED PRODUCTS



TORQUE-ARM Shaft Mount Speed Reducers

V-BELT DRIVES FOR TXT215, TXT225 & SCXT215, SCXT225 REDUCERS 3VX, 5VX, 8VX, AX, BX, CX AND DX BELTS REQUIRED (con't)

These are typical drives for average service conditions, For other conditions. output speeds or motor speeds see reducer specification for minimum driven sheave diameter and use V-belt selection tables

Size 115 Driven by 1750 RPM Motors										Size 125 Driven by 1750 RPM Motors									
Out-put RPM	V-belt Drive Ratio	Sheave Diameters *		Qty & Belt Size	Out-put RPM	V-belt Drive Ratio	Sheave Diameters *		Qty & Belt Size	Out-put RPM	V-belt Drive Ratio	Sheave Diameters *		Qty & Belt Size	Out-put RPM	V-belt Drive Ratio	Sheave Diameters *		Qty & Belt Size
		Driver	Driven				Driver	Driven				Driver	Driven				Driver	Driven	
50	2.48	5.00	12.40	2-B	106	1.17	4.80	5.60	3-B	33	2.29	2.65	6.00	3-3V	69	1.08	6.00	6.50	2-3V
51	2.42	6.20	15.00	2-A	107	1.16	5.60	6.50	3-3V	33	2.25	4.00	9.00	2-A	69	1.08	4.80	5.20	2-B
52	2.41	3.35	8.00	3-3V	107	1.16	7.40	8.60	2-B	34	2.21	3.65	8.00	2-3V	70	1.06	5.00	5.30	2-3V
52	2.38	5.20	12.40	2-B	109	1.14	4.20	4.80	4-A	34	2.21	4.80	10.60	2-A	70	1.07	5.60	6.00	2-B
53	2.32	3.00	6.90	4-3V	111	1.12	5.00	5.60	3-3V	35	2.13	2.65	5.60	3-3V	71	1.06	5.30	5.60	2-3V
53	2.33	3.00	7.00	4-A	111	1.12	5.00	5.60	3-B	35	2.14	4.20	9.00	2-A	71	1.06	3.60	3.80	3-A
54	2.29	4.80	11.00	2-B	113	1.10	4.20	4.60	4-A	36	2.08	3.15	6.50	3-3V	72	1.04	5.00	5.20	2-B
56	2.21	3.65	8.00	3-3V	115	1.08	6.00	6.50	3-3V	36	2.05	4.00	8.20	2-A	75	1.00	4.50	4.50	3-3V
56	2.20	5.00	11.00	2-B	115	1.08	4.80	5.20	3-B	37	2.02	2.65	5.30	3-3V	75	1.00	6.20	6.20	2-B
58	2.13	5.00	10.60	2-3V	117	1.06	5.00	5.30	3-3V	37	2.04	4.60	9.40	2-B	77	0.97	6.40	6.20	2-B
58	2.16	3.80	8.20	3-A	117	1.06	6.20	6.60	3-B	38	1.95	4.12	8.00	2-3V	79	0.94	6.90	6.50	2-3V
59	2.12	5.20	11.00	2-B	119	1.04	5.00	5.20	3-B	38	1.95	4.20	8.20	2-A	79	0.94	6.60	6.20	2-B
61	2.04	6.90	14.00	2-3V	121	1.03	6.60	6.80	3-B	39	1.90	3.65	6.90	2-3V	80	0.93	6.00	5.60	3-3V
61	2.04	5.40	11.00	2-B	124	1.00	4.12	4.12	4-3V	39	1.93	3.00	5.80	3-A	80	0.94	6.40	6.00	2-B
63	1.96	4.80	9.40	2-B	124	1.00	8.60	8.60	2-B	40	1.88	3.00	5.60	3-3V	81	0.92	3.65	3.35	4-3V
65	1.90	3.65	6.90	3-3V	128	0.97	6.00	5.80	3-A	40	1.86	4.40	8.20	2-A	81	0.92	7.40	6.80	2-B
65	1.90	5.80	11.00	2-B	129	0.96	5.00	4.80	3-B	41	1.81	2.65	4.75	3-3V	82	0.91	4.50	4.12	3-3V
66	1.88	3.00	5.60	4-3V	131	0.95	5.60	5.30	3-3V	41	1.80	5.00	9.00	2-A	82	91	6.60	6.00	2-B
66	1.88	5.00	9.40	2-B	131	0.95	3.80	3.60	5-A	42	1.79	3.65	6.50	2-3V	83	0.90	5.00	4.50	3-3V
67	1.87	3.00	5.60	4-A	133	0.93	6.00	5.60	3-3V	42	1.78	4.60	8.20	2-A	83	0.89	3.80	3.40	4-A
68	1.83	5.80	10.60	2-A	133	0.93	5.80	5.40	3-B	44	1.68	4.12	6.90	2-3V	84	0.88	4.12	3.65	4-3V
69	1.80	3.35	6.00	3-3V	134	0.93	5.40	5.00	3-B	44	1.71	4.80	8.20	2-A	84	0.89	7.40	6.60	2-B
69	1.79	4.80	8.60	2-B	135	0.92	6.50	6.00	3-3V	45	1.65	3.65	6.00	2-3V	85	0.88	6.00	5.30	3-3V
71	1.75	8.00	14.00	2-3V	135	0.92	5.20	4.80	3-B	45	1.67	2.60	7.00	2-A	85	0.88	6.60	5.80	2-B
71	1.74	5.40	9.40	2-B	136	0.91	4.50	4.12	4-3V	46	1.62	2.80	4.50	3-3V					
72	1.72	5.00	8.60	2-B	136	0.91	9.40	8.60	2-B	46	1.61	4.60	7.40	2-B					
74	1.68	3.35	5.60	3-3V	137	0.91	4.40	4.00	4-A	47	1.59	3.35	5.30	3-3V					
74	1.68	5.60	9.40	2-B	139	0.90	5.30	4.75	3-3V	47	1.59	5.40	8.60	2-B					
76	1.64	6.50	10.60	2-3V	139	0.89	5.60	5.00	3-B	48	1.54	3.65	5.60	3-3V					

Note: These V-belts drives are designed for average service and are based on reducer ratings. Where fire hazards are prevalent and fire prevention laws apply, it is recommended that drives be redesigned using a service factor of 2.0 on the hp rating of the motor - refer to V-belt drive tables or consult DODGE

* DODGE stock sheaves. outside diameters shown for DYNA-V (3V); pitch diameters for A & B sheaves. All ratios based on P.D. Sheaves in shaded area represent speed up drives.

FEATURES/BENEFITS PAGE G2-3	NOMENCLATURE PAGE G2-11	SELECTION/DIMENSIONS PAGE G2-144	RELATED PRODUCTS PAGE G2-152
--------------------------------	----------------------------	-------------------------------------	---------------------------------

RELATED PRODUCTS



TORQUE-ARM Shaft Mount Speed Reducers V-BELT DRIVES FOR TXT315A, TXT325A & SCXT315A, SCXT325A REDUCERS 3VX, 5VX, 8VX, AX, BX, CX AND DX BELTS REQUIRED

These are typical drives for average service conditions, For other conditions. output speeds or motor speeds see reducer specification for minimum driven sheave diameter and use V-belt selection tables

Size 315A Driven by 1750 RPM Motors										Size 325A Driven by 1750 RPM Motors									
Out-put RPM	V-belt Drive Ratio	Sheave Diameters *		Qty & Belt Size	Out-put RPM	V-belt Drive Ratio	Sheave Diameters *		Qty & Belt Size	Out-put RPM	V-belt Drive Ratio	Sheave Diameters *		Qty & Belt Size	Out-put RPM	V-belt Drive Ratio	Sheave Diameters *		Qty & Belt Size
		Driver	Driven				Driver	Driven				Driver	Driven				Driver	Driven	
12	9.60	2.65	25.00	3-3V	71	1.67	6.60	11.00	2-B	10	7.29	2.65	19.00	2-3V	48	1.46	4.12	6.00	3-3V
16	7.29	2.65	19.00	3-3V	73	1.61	5.00	8.00	3-3V	11	6.42	3.00	19.00	2-3V	48	1.48	5.00	7.40	2-B
18	6.42	3.00	19.00	2-3V	73	1.62	5.80	9.40	3-B	12	6.11	3.15	19.00	2-3V	49	1.43	5.60	8.00	2-3V
19	6.11	3.15	19.00	3-3V	75	1.57	6.00	9.40	3-B	12	6.00	3.00	18.00	3-A	49	1.43	6.00	8.60	2-B
20	5.74	3.35	19.00	3-3V	76	1.54	4.50	6.90	4-3V	13	5.37	2.65	14.00	3-3V	50	1.42	3.35	4.75	3-3V
20	6.00	3.00	18.00	3-A	76	1.54	4.80	7.40	3-B	13	5.63	3.20	18.00	2-A	50	1.42	4.80	6.80	2-B
21	5.63	3.20	18.00	3-A	77	1.52	4.20	6.40	4-A	14	5.07	2.80	14.00	3-3V	51	1.38	5.00	6.90	2-3V
22	5.37	2.65	14.00	3-3V	79	1.49	7.40	11.00	2-B	14	5.00	3.60	18.00	2-A	51	1.39	3.60	5.00	3-A
22	5.29	3.40	18.00	3-A	81	1.45	4.50	6.50	4-3V	15	4.73	3.00	14.00	2-3V	52	1.38	3.65	5.00	3-3V
23	5.07	2.80	14.00	3-3V	81	1.45	4.40	6.40	4-A	15	4.69	3.20	15.00	2-A	52	1.38	4.80	6.60	2-B
24	5.00	3.00	15.00	3-A	83	1.42	4.80	6.80	3-B	16	4.50	3.15	14.00	2-3V	53	1.35	3.35	4.50	3-3V
25	4.73	3.00	14.00	3-3V	85	1.38	5.00	6.90	3-3V	16	4.41	3.40	15.00	2-A	53	1.33	4.80	6.40	2-B
25	4.69	3.20	15.00	3-A	85	1.38	4.20	5.80	4-A	17	4.23	3.35	14.00	2-3V	54	1.30	5.00	6.50	2-3V
27	4.29	4.20	18.00	2-A	87	1.36	14.00	19.00	2-3V	17	4.17	3.60	15.00	2-A	54	1.32	5.00	6.60	2-B
28	4.26	4.50	19.00	2-3V	87	1.35	4.60	6.20	4-A	18	3.88	3.65	14.00	2-3V	56	1.27	4.75	6.00	3-3V
28	4.17	3.60	15.00	3-A	89	1.33	8.00	10.60	2-3V	18	3.95	3.80	15.00	2-A	56	1.27	5.20	6.60	2-B
29	4.06	2.65	10.60	3-3V	89	1.32	5.00	6.60	3-B	19	3.83	5.00	19.00	2-3V	57	1.23	5.60	6.90	2-3V
29	4.00	3.00	12.00	3-A	91	1.29	4.12	5.30	4-3V	19	3.75	3.20	12.00	3-A	57	1.25	4.80	6.00	2-B
31	3.84	2.80	10.60	3-3V	91	1.29	4.80	6.20	3-B	20	3.58	3.00	10.60	3-3V	58	1.23	5.30	6.50	2-3V
31	3.75	3.20	12.00	3-A	92	1.28	5.00	6.40	3-B	20	3.53	3.00	10.60	3-A	58	1.23	5.20	6.40	2-B
32	3.68	5.00	18.40	2-B	94	1.25	4.50	5.60	4-3V	21	3.43	4.12	14.00	2-3V	59	1.20	5.00	6.00	2-3V
34	3.43	4.12	14.00	3-3V	94	1.25	4.80	6.00	3-B	21	3.31	3.20	10.60	3-A	59	1.21	4.80	5.80	2-B
34	3.41	4.40	15.00	3-A	96	1.23	5.30	6.50	3-3V	22	3.20	3.35	10.60	3-3V	60	1.18	4.50	5.30	3-3V
36	3.31	3.20	10.60	4-A	96	1.23	5.20	6.40	3-B	22	3.26	4.60	15.00	2-A	60	1.19	5.40	6.40	2-B
37	3.20	3.35	10.60	3-3V	98	1.20	5.00	6.00	3-3V	23	3.06	2.65	8.00	3-3V	61	1.16	5.60	6.50	2-3V
37	3.16	3.80	12.00	3-A	98	1.20	5.00	6.00	3-B	23	3.12	3.40	10.60	3-A	61	1.17	4.80	5.60	2-B
38	3.13	4.50	14.00	3-3V	99	1.19	5.20	6.20	3-B	25	2.89	2.80	8.00	3-3V	62	1.15	6.00	6.90	2-3V
38	3.08	5.00	15.40	2-B	101	1.16	5.60	6.50	3-3V	25	2.86	4.20	12.00	2-A	62	1.15	5.40	6.20	2-B
40	2.93	3.65	10.60	3-3V	101	1.16	7.40	8.60	2-B	26	2.69	3.00	8.00	3-3V	63	1.12	5.00	5.60	2-3V
40	2.94	3.60	10.60	3-A	103	1.14	4.20	4.80	4-A	26	2.73	4.40	12.00	2-A	63	1.13	4.80	5.40	2-B
41	2.85	5.40	15.40	2-B	104	1.13	5.30	6.00	3-3V	27	2.63	2.65	6.90	3-3V	64	1.11	4.50	5.00	3-3V
42	2.82	5.00	14.00	2-3V	104	1.13	4.60	5.20	4-A	27	2.65	4.00	10.60	2-A	64	1.12	5.20	5.80	2-B
42	2.79	3.80	10.60	3-A	105	1.12	5.00	5.60	3-3V	29	2.48	2.65	6.50	3-3V	65	1.08	6.00	6.50	2-3V
44	2.69	3.00	8.00	4-3V	105	1.13	4.80	5.40	3-B	29	2.41	4.40	10.60	2-A	65	1.08	4.80	5.20	2-B
44	2.65	4.00	10.60	3-A	107	1.10	4.20	4.60	4-A	30	2.35	2.80	6.50	3-3V	66	1.07	5.60	6.00	2-3V
45	2.59	4.12	10.60	3-3V	108	1.09	4.12	4.50	4-3V	30	2.39	4.60	11.00	2-B	66	1.08	5.00	5.40	2-B
45	2.61	4.60	12.00	3-A	108	1.09	8.60	9.40	2-B	31	2.29	2.65	6.00	3-3V	68	1.04	5.00	5.20	2-B
47	2.51	5.60	14.00	2-3V	109	1.08	4.80	5.20	3-B	31	2.25	4.00	9.00	2-A	69	1.03	6.00	6.20	2-B
47	2.48	5.00	12.40	2-B	111	1.06	5.00	5.30	3-3V	32	2.21	3.65	8.00	2-3V	71	1.00	5.00	5.00	2-3V

Note: These V-belts drives are designed for average service and are based on reducer ratings. Where fire hazards are prevalent and fire prevention laws apply, it is recommended that drives be redesigned using a service factor of 2.0 on the hp rating of the motor - refer to V-belt drive tables or consult DODGE

* DODGE stock sheaves. outside diameters shown for DYNA-V (3V); pitch diameters for A & B sheaves. All ratios based on P.D. Sheaves in shaded area represent speed up drives.

FEATURES/BENEFITS PAGE G2-3	NOMENCLATURE PAGE G2-11	SELECTION/DIMENSIONS PAGE G2-144	RELATED PRODUCTS PAGE G2-152
--------------------------------	----------------------------	-------------------------------------	---------------------------------

RELATED PRODUCTS



TORQUE-ARM Shaft Mount Speed Reducers

V-BELT DRIVES FOR TXT315A, TXT325A & SCXT315A, SCXT325A REDUCERS 3VX, 5VX, 8VX, AX, BX, CX AND DX BELTS REQUIRED (con't)

These are typical drives for average service conditions. For other conditions, output speeds or motor speeds see reducer specification for minimum driven sheave diameter and use V-belt selection tables

Size 315A Driven by 1750 RPM Motors										Size 325A Driven by 1750 RPM Motors									
Out-put RPM	V-belt Drive Ratio	Sheave Diameters *		Qty & Belt Size	Out-put RPM	V-belt Drive Ratio	Sheave Diameters *		Qty & Belt Size	Out-put RPM	V-belt Drive Ratio	Sheave Diameters *		Qty & Belt Size	Out-put RPM	V-belt Drive Ratio	Sheave Diameters *		Qty & Belt Size
		Driver	Driven				Driver	Driven				Driver	Driven				Driver	Driven	
50	2.34	6.00	14.00	2-3V	111	1.06	6.40	6.80	3-B	32	2.21	480	10.60	2-A	71	1.00	5.00	5.00	2-B
50	2.37	3.80	9.00	3-A	113	1.04	5.00	5.20	3-B	33	2.13	5.00	10.60	2-3V	73	0.96	5.60	5.40	2-B
52	2.24	4.75	10.60	3-3V	118	1.00	4.12	4.12	4-3V	33	2.12	5.20	11.00	2-B	74	0.95	3.15	3.00	4-3V
52	2.28	3.60	8.20	4-A	118	1.00	8.60	8.60	2-B	34	2.08	3.35	6.90	3-3V	74	0.96	5.00	4.80	2-B
54	2.19	3.00	6.50	5-3V	121	0.97	6.40	6.20	3-A	34	2.07	5.80	12.00	2-A	75	0.94	5.30	5.00	2-3V
54	2.19	3.20	7.00	5-A	122	0.96	5.20	5.00	3-B	35	2.02	3.00	6.00	4-3V	75	0.95	3.80	3.60	3-A
56	2.12	5.20	11.00	3-B	124	0.95	5.60	5.30	3-3V	35	2.04	5.40	11.00	2-B	76	0.93	6.00	5.60	2-3V
57	2.08	3.35	6.90	4-3V	124	0.95	3.80	3.60	5-A	36	1.95	3.35	6.50	3-3V	76	0.93	5.60	5.20	2-B
57	2.05	4.00	8.20	4-A	126	0.93	6.00	5.60	3-3V	36	1.96	4.80	9.40	2-B	78	0.90	6.20	5.60	2-B
59	2.01	5.30	10.60	3-3V	126	0.93	5.80	5.40	3-B	37	1.90	3.65	6.90	3-3V	79	0.90	5.30	4.75	2-3V
59	2.00	6.20	12.40	2-B	128	0.92	4.80	4.40	4-A	37	1.90	5.80	11.00	2-B	79	0.89	5.60	5.00	2-B
61	1.92	3.15	6.00	5-3V	129	0.91	4.50	4.12	4-3V	39	1.80	3.35	6.00	3-3V	80	0.88	6.00	5.30	2-3V
61	1.94	6.40	12.40	2-B	129	0.91	9.40	8.60	2-B	39	1.81	5.20	9.40	2-B	80	0.88	5.20	4.60	2-B
63	1.88	3.00	5.60	5-3V	130	0.90	6.20	5.60	3-A	40	1.79	3.65	6.50	3-3V	81	0.87	6.20	5.40	2-B
63	1.88	6.60	12.40	2-B	131	0.90	5.30	4.75	3-3V	40	1.79	4.80	8.60	2-B	82	0.86	6.50	5.60	2-3V
64	1.82	6.80	12.40	2-B	131	0.90	5.80	5.20	3-B	41	1.72	5.00	8.60	2-B	82	0.86	5.80	5.00	2-B
65	1.80	3.35	6.00	4-3V	133	0.88	6.00	5.30	3-3V	43	1.65	3.65	6.00	3-3V	83	0.85	5.40	4.60	2-B
65	1.80	5.00	9.00	3-A	133	0.88	5.20	4.60	3-B	43	1.65	5.20	8.60	2-B	85	0.83	6.00	5.00	2-3V
66	1.79	4.50	8.00	3-3V	134	0.88	4.80	4.20	4-A	44	1.61	5.00	8.00	2-3V	85	0.83	6.00	5.00	2-B
66	1.77	6.20	11.00	2-B	136	0.87	4.75	4.12	4-3V	44	1.59	5.40	8.60	2-B					
68	1.72	6.40	11.00	2-B	136	0.86	5.80	5.00	3-B	45	1.59	3.35	5.30	3-3V					
69	1.69	3.15	5.30	5-3V	137	0.86	6.50	5.60	3-3V	45	1.57	6.00	9.40	2-B					
69	1.71	4.80	8.20	3-A	137	0.86	8.60	7.40	2-B	46	1.54	3.65	5.60	3-3V					
70	1.68	4.12	6.90	3-3V	138	0.85	5.40	4.60	3-B	46	1.54	4.80	7.40	2-B					
70	1.68	3.80	6.40	4-A	139	0.85	5.60	4.75	3-3V	47	1.50	3.35	5.00	3-3V					
71	1.65	3.65	6.00	4-3V	139	0.84	6.40	5.40	3-A	47	1.50	6.00	9.00	2-A					

Note: These V-belts drives are designed for average service and are based on reducer ratings. Where fire hazards are prevalent and fire prevention laws apply, it is recommended that drives be redesigned using a service factor of 2.0 on the hp rating of the motor - refer to V-belt drive tables or consult DODGE

* DODGE stock sheaves, outside diameters shown for DYNA-V (3V); pitch diameters for A & B sheaves. All ratios based on P.D. Sheaves in shaded area represent speed up drives.

FEATURES/BENEFITS PAGE G2-3	NOMENCLATURE PAGE G2-11	SELECTION/DIMENSIONS PAGE G2-144	RELATED PRODUCTS PAGE G2-152
--------------------------------	----------------------------	-------------------------------------	---------------------------------

RELATED PRODUCTS



TORQUE-ARM Shaft Mount Speed Reducers V-BELT DRIVES FOR TXT415A, TXT425A & SCXT415A, SCXT425A REDUCERS 3VX, 5VX, 8VX, AX, BX, CX AND DX BELTS REQUIRED

These are typical drives for average service conditions, For other conditions. output speeds or motor speeds see reducer specification for minimum driven sheave diameter and use V-belt selection tables

Size 415A Driven by 1750 RPM Motors										Size 425A Driven by 1750 RPM Motors									
Out-put RPM	V-belt Drive Ratio	Sheave Diameters *		Qty & Belt Size	Out-put RPM	V-belt Drive Ratio	Sheave Diameters *		Qty & Belt Size	Out-put RPM	V-belt Drive Ratio	Sheave Diameters *		Qty & Belt Size	Out-put RPM	V-belt Drive Ratio	Sheave Diameters *		Qty & Belt Size
		Driver	Driven				Driver	Driven				Driver	Driven				Driver	Driven	
12	9.60	2.65	25.00	3-3V	75	1.54	4.80	7.40	4-B	10	6.89	2.80	19.00	2-3V	48	1.49	7.40	11.00	2-B
13	9.07	2.80	25.00	3-3V	77	1.50	6.00	9.00	4-A	10	6.89	2.80	19.00	2-3V	49	1.46	4.12	6.00	4-3V
15	7.56	3.35	25.00	3-3V	79	1.46	4.75	6.90	5-3V	11	6.42	3.00	19.00	3-3V	49	1.48	5.00	7.40	3-B
16	7.29	2.65	19.00	3-3V	79	1.47	6.40	9.40	3-B	12	6.11	3.15	19.00	3-3V	50	1.43	5.60	8.00	3-3V
18	6.42	3.00	19.00	3-3V	81	1.43	5.60	8.00	4-3V	12	6.00	3.00	18.00	3-A	50	1.43	4.20	6.00	4-A
19	6.11	3.15	19.00	3-3V	81	1.43	6.00	8.60	3-B	14	5.07	2.80	14.00	3-3V	51	1.42	4.80	6.80	3-B
19	6.00	3.00	18.00	3-A	84	1.38	5.00	6.90	4-3V	14	5.00	3.00	15.00	3-A	52	1.38	5.00	6.90	3-3V
21	5.61	4.50	25.00	3-3V	84	1.38	4.80	6.60	4-B	15	4.71	3.00	14.00	3-3V	52	1.38	4.80	6.60	3-B
21	5.63	3.20	18.00	4-A	86	1.34	6.40	8.60	3-B	15	4.69	3.20	15.00	3-A	53	1.36	4.12	5.60	4-3V
23	5.00	3.00	15.00	4-A	87	1.34	4.50	6.00	5-3V	16	4.50	3.15	14.00	3-3V	53	1.36	5.00	6.80	3-B
24	4.73	3.00	14.00	4-3V	87	1.33	4.80	6.40	4-B	16	4.41	3.40	15.00	3-A	55	1.30	5.00	6.50	3-3V
24	4.74	3.80	18.00	3-A	88	1.31	7.10	9.25	3-5V	17	4.26	4.50	19.00	2-3V	55	1.31	5.20	6.80	3-B
26	4.50	3.15	14.00	4-3V	88	1.32	5.00	6.60	4-B	17	4.29	4.20	18.00	2-A	56	1.29	4.12	5.30	4-3V
26	4.41	3.40	15.00	4-A	90	1.29	4.80	6.20	4-B	18	4.06	2.65	10.60	3-3V	56	1.29	4.80	6.20	3-B
28	4.17	3.60	15.00	4-A	91	1.27	4.75	6.00	5-3V	18	4.00	3.00	12.00	3-A	57	1.27	4.75	6.00	4-3V
29	4.03	4.75	19.00	2-3V	91	1.26	6.80	8.60	3-B	19	3.88	3.65	14.00	2-3V	57	1.27	7.40	9.40	2-B
29	3.95	3.80	15.00	3-A	92	1.26	5.40	6.80	4-B	19	3.75	3.20	12.00	3-A	58	1.23	5.30	6.50	3-3V
31	3.75	4.00	15.00	4-A	93	1.25	4.80	6.00	5-B	20	3.58	3.00	10.60	4-3V	58	1.24	5.00	6.20	3-B
32	3.58	3.00	10.60	5-3V	94	1.23	5.30	6.50	5-3V	20	3.53	3.00	10.60	4-A	59	1.22	4.12	5.00	4-3V
32	3.57	4.20	15.00	4-A	94	1.23	6.00	7.40	4-B	21	3.40	3.15	10.60	4-3V	59	1.21	4.80	5.80	3-B
34	3.40	3.15	10.60	5-3V	96	1.20	5.00	6.00	5-3V	21	3.41	5.40	18.40	2-B	60	1.20	5.00	6.00	3-3V
34	3.41	4.40	15.00	4-A	96	1.21	4.80	5.80	5-B	23	3.18	6.00	19.00	2-3V	60	1.20	5.00	6.00	3-B
35	3.33	3.60	12.00	4-A	97	1.19	6.20	7.40	4-B	23	3.08	5.00	15.40	2-B	61	1.18	4.50	5.30	4-3V
37	3.13	4.50	14.00	3-3V	98	1.18	4.75	5.60	6-3V	24	2.93	3.65	10.60	3-3V	61	1.19	5.40	6.40	3-B
37	3.16	3.80	12.00	4-A	98	1.18	5.60	6.60	4-B	24	2.94	3.60	10.60	3-A	62	1.15	4.12	4.75	4-3V
38	3.08	5.00	15.40	3-B	99	1.17	5.80	6.80	4-B	25	2.82	5.00	14.00	2-3V	62	1.16	7.40	8.60	2-B
39	2.93	3.65	10.60	4-3V	101	1.15	8.50	9.75	3-5V	25	2.85	5.40	15.40	2-B	64	1.12	5.00	5.60	3-3V
39	2.94	3.60	10.60	4-A	101	1.14	5.60	6.40	4-B	26	2.77	6.90	19.00	2-3V	64	1.13	4.80	5.40	3-B
41	2.82	5.00	14.00	3-3V	103	1.12	5.00	5.60	5-3V	26	2.79	3.80	10.60	3-A	65	1.11	4.50	5.00	4-3V
41	2.85	5.40	15.40	3-B	103	1.13	4.80	5.40	5-B	27	2.69	3.00	8.00	4-3V	65	1.11	5.40	6.00	3-B
43	2.70	4.60	12.40	4-B	104	1.12	4.75	5.30	6-3V	27	2.65	4.00	10.60	3-A	66	1.09	4.12	4.50	4-3V
44	2.66	5.30	14.00	3-3V	104	1.11	5.60	6.20	4-B	28	2.56	3.15	8.00	4-3V	66	1.08	4.80	5.20	3-B
44	2.61	4.60	12.00	4-A	105	1.10	5.80	6.40	4-B	28	2.58	4.80	12.40	2-B	67	1.07	5.60	6.00	4-3V
46	2.51	5.60	14.00	3-3V	106	1.09	8.50	9.25	3-5V	29	2.51	5.60	14.00	2-3V	67	1.06	6.20	6.60	3-B
46	2.50	4.80	12.00	4-A	106	1.09	8.60	9.40	3-B	29	2.48	5.00	12.40	2-B	68	1.06	5.00	5.30	4-3V
48	2.41	4.40	10.60	4-A	108	1.07	5.60	6.00	5-3V	30	2.41	3.35	8.00	3-3V	68	1.06	6.40	6.80	3-B
49	2.37	4.50	10.60	4-3V	108	1.07	5.80	6.20	4-B	30	2.38	5.20	12.40	2-B	69	1.04	5.00	5.20	4-B
49	2.38	5.20	12.40	3-B	110	1.05	4.75	5.00	6-3V	32	2.24	4.75	10.60	3-3V	70	1.03	6.20	6.40	3-B

Note: These V-belts drives are designed for average service and are based on reducer ratings. Where fire hazards are prevalent and fire prevention laws apply, it is recommended that drives be redesigned using a service factor of 2.0 on the hp rating of the motor - refer to V-belt drive tables or consult DODGE

* DODGE stock sheaves. outside diameters shown for DYNA-V (3V); pitch diameters for A & B sheaves. All ratios based on P.D. Sheaves in shaded area represent speed up drives.

FEATURES/BENEFITS PAGE G2-3	NOMENCLATURE PAGE G2-11	SELECTION/DIMENSIONS PAGE G2-144	RELATED PRODUCTS PAGE G2-152
--------------------------------	----------------------------	-------------------------------------	---------------------------------

RELATED PRODUCTS



TORQUE-ARM Shaft Mount Speed Reducers

V-BELT DRIVES FOR TXT415A, TXT425A & SCXT415A, SCXT425A REDUCERS 3VX, 5VX, 8VX, AX, BX, CX AND DX BELTS REQUIRED (con't)

These are typical drives for average service conditions. For other conditions, output speeds or motor speeds see reducer specification for minimum driven sheave diameter and use V-belt selection tables

Size 415A Driven by 1750 RPM Motors										Size 425A Driven by 1750 RPM Motors									
Out-put RPM	V-belt Drive Ratio	Sheave Diameters *		Qty & Belt Size	Out-put RPM	V-belt Drive Ratio	Sheave Diameters *		Qty & Belt Size	Out-put RPM	V-belt Drive Ratio	Sheave Diameters *		Qty & Belt Size	Out-put RPM	V-belt Drive Ratio	Sheave Diameters *		Qty & Belt Size
		Driver	Driven				Driver	Driven				Driver	Driven				Driver	Driven	
51	2.25	4.00	9.00	5-A	110	1.06	9.00	9.50	3-C	32	2.28	3.60	8.20	4-A	72	1.00	5.00	5.00	4-3V
52	2.24	4.75	10.60	4-3V	111	1.04	5.00	5.20	5-B	33	2.21	3.65	8.00	4-3V	72	1.00	6.20	6.20	3-B
52	2.21	5.60	12.40	3-B	116	1.00	5.00	5.00	5-3V	33	2.21	4.80	10.60	3-A	74	0.97	6.40	6.20	3-B
54	2.13	5.00	10.60	3-3V	116	1.00	5.80	5.80	4-B	34	2.13	5.00	10.60	3-3V	75	0.96	5.00	4.80	4-B
54	2.14	4.20	9.00	4-A	119	0.97	6.40	6.20	4-B	34	2.12	5.00	10.60	3-A	77	0.93	6.00	5.60	4-3V
55	2.12	5.20	11.00	3-B	120	0.97	5.80	5.60	5-B	35	2.08	3.35	6.90	4-3V	77	0.94	6.40	6.00	3-B
56	2.07	5.80	12.00	3-A	122	0.95	5.60	5.30	6-3V	35	2.04	4.60	9.40	3-B	78	0.91	4.50	4.12	5-3V
57	2.04	6.90	14.00	3-3V	122	0.94	9.00	8.50	3-C	36	2.02	3.00	6.00	5-3V	78	0.92	5.20	4.80	4-B
57	2.04	5.40	11.00	3-B	123	0.94	5.30	5.00	6-3V	36	2.00	6.20	12.40	2-B	79	0.91	6.60	6.00	3-B
59	1.95	4.12	8.00	4-3V	123	0.94	6.80	6.40	4-B	37	1.95	4.12	8.00	3-3V	80	0.90	5.30	4.75	4-3V
59	1.96	4.80	9.40	3-B	125	0.92	6.50	6.00	5-3V	37	1.94	6.40	12.40	2-B	80	0.89	5.60	5.00	4-B
61	1.90	5.60	10.60	3-3V	125	0.93	5.40	5.00	6-B	38	1.88	3.00	5.60	5-3V	81	0.88	6.00	5.30	4-3V
61	1.90	5.80	11.00	3-B	127	0.91	6.60	6.00	5-B	38	1.88	6.60	12.40	2-B	81	0.88	5.20	4.60	4-B
62	1.88	5.00	9.40	3-B	128	0.90	6.20	5.60	5-B	39	1.82	6.80	12.40	2-B	82	0.88	6.60	5.80	3-B
64	1.80	10.60	19.00	2-3V	129	0.90	5.30	4.75	6-3V	40	1.79	4.50	8.00	3-3V	83	0.87	6.90	6.00	3-3V
64	1.81	5.20	9.40	3-B	129	0.90	5.80	5.20	5-B	40	1.77	6.20	11.00	2-B	83	0.86	5.80	5.00	4-B
66	1.75	8.00	14.00	2-3V	131	0.88	6.00	5.30	6-3V	41	1.75	8.00	14.00	2-3V	84	0.85	6.80	5.80	3-B
66	1.74	5.40	9.40	3-B	131	0.88	5.20	4.60	6-B	41	1.74	5.40	9.40	3-B	85	0.85	5.60	4.75	4-3V
67	1.72	6.40	11.00	3-B	133	0.87	6.90	6.00	5-3V	43	1.68	4.12	6.90	4-3V	85	0.84	6.40	5.40	4-A
69	1.67	7.10	11.80	3-5V	133	0.87	6.00	5.20	5-B	43	1.68	7.40	12.40	2-B	86	0.83	6.00	5.00	4-3V
69	1.67	6.60	11.00	3-B	135	0.85	11.00	9.40	3-B	44	1.64	6.50	10.60	3-3V					
70	1.65	5.20	8.60	4-B	136	0.85	6.60	5.60	5-B	44	1.62	5.80	9.40	3-B					
72	1.61	5.00	8.00	4-3V	137	0.85	5.60	4.75	6-3V	45	1.61	5.00	8.00	3-3V					
72	1.62	6.80	11.00	3-B	137	0.84	6.40	5.40	5-B	45	1.59	5.40	8.60	3-B					
73	1.59	5.40	8.60	4-B	138	0.84	7.40	6.20	4-B	46	1.55	5.80	9.00	3-A					
74	1.57	6.00	9.40	3-B	139	0.83	6.00	5.00	6-3V	47	1.51	5.30	8.00	3-3V					
75	1.54	4.50	6.90	5-3V	139	0.83	6.00	5.00	6-B	47	1.54	4.80	7.40	3-B					

Note: These V-belts drives are designed for average service and are based on reducer ratings. Where fire hazards are prevalent and fire prevention laws apply, it is recommended that drives be redesigned using a service factor of 2.0 on the hp rating of the motor - refer to V-belt drive tables or consult DODGE

* DODGE stock sheaves. Outside diameters shown for DYNA-V (3V); pitch diameters for A & B sheaves. All ratios based on P.D. Sheaves in shaded area represent speed up drives.

FEATURES/BENEFITS PAGE G2-3	NOMENCLATURE PAGE G2-11	SELECTION/DIMENSIONS PAGE G2-144	RELATED PRODUCTS PAGE G2-152
--------------------------------	----------------------------	-------------------------------------	---------------------------------

RELATED PRODUCTS



TORQUE-ARM Shaft Mount Speed Reducers V-BELT DRIVES FOR TXT515B, TXT525B & SCXT515B, SCXT525B REDUCERS 3VX, 5VX, 8VX, AX, BX, CX AND DX BELTS REQUIRED

These are typical drives for average service conditions, For other conditions, output speeds or motor speeds see reducer specification for minimum driven sheave diameter and use V-belt selection tables

Size 515B Driven by 1750 RPM Motors								Size 525B Driven by 1750 RPM Motors											
Out-put RPM	V-belt Drive Ratio	Sheave Diameters *		Qty & Belt Size	Out-put RPM	V-belt Drive Ratio	Sheave Diameters *		Qty & Belt Size	Out-put RPM	V-belt Drive Ratio	Sheave Diameters *		Qty & Belt Size					
13	8.46	3.00	25.00	4-3V	67	1.69	4.75	8.00	6-3V	10	6.89	2.80	19.00	3-3V	48	1.43	6.00	8.60	3-B
14	8.05	3.15	25.00	3-3V	67	1.71	4.80	8.20	6-A	11	6.42	3.00	19.00	3-3V	49	1.38	5.00	6.90	4-3V
14	8.26	4.60	38.00	3-B	68	1.67	7.10	11.80	3-5V	11	6.00	3.00	18.00	3-A	49	1.39	6.20	8.60	3-B
15	7.56	3.35	25.00	3-3V	68	1.68	7.40	12.40	3-B	12	5.74	3.35	19.00	3-3V	50	1.37	4.75	6.50	5-3V
16	6.93	3.65	25.00	3-3V	70	1.62	5.80	9.40	4-B	12	5.63	3.20	18.00	4-A	50	1.38	4.80	6.60	4-B
17	6.52	4.60	30.00	3-B	71	1.61	5.00	8.00	5-3V	13	5.26	3.65	19.00	3-3V	51	1.34	4.50	6.00	5-3V
19	6.11	3.15	19.00	3-3V	71	1.59	5.40	8.60	5-B	13	5.29	3.40	18.00	4-A	51	1.33	4.80	6.40	4-B
19	6.00	3.00	18.00	4-A	73	1.57	6.00	9.40	4-B	14	4.73	3.00	14.00	4-3V	52	1.30	5.30	6.90	4-3V
20	5.74	3.35	19.00	4-3V	74	1.54	6.90	10.60	4-3V	14	5.00	3.00	15.00	4-A	52	1.32	5.00	6.60	4-B
20	5.63	3.20	18.00	5-A	74	1.54	5.60	8.60	4-B	15	4.50	3.15	14.00	4-3V	53	1.30	5.00	6.50	4-3V
21	5.31	4.75	25.00	3-3V	76	1.49	7.40	11.00	4-B	15	4.69	3.20	15.00	4-A	53	1.29	4.80	6.20	4-B
21	5.29	3.40	18.00	5-A	77	1.48	8.00	11.80	3-5V	16	4.23	3.35	14.00	3-3V	54	1.27	4.75	6.00	5-3V
22	5.26	3.65	19.00	4-3V	77	1.47	6.40	9.40	4-B	16	4.41	3.40	15.00	4-A	54	1.26	6.80	8.60	3-B
22	5.21	4.80	25.00	3-B	78	1.46	4.75	6.90	8-3V	17	4.03	4.75	19.00	2-3V	55	1.23	5.60	6.90	4-3V
24	4.66	4.12	19.00	3-3V	78	1.46	5.60	8.20	6-A	17	3.95	3.80	15.00	3-A	55	1.25	4.80	6.00	4-B
24	4.74	3.80	18.00	4-A	80	1.42	6.60	9.40	4-B	19	3.58	3.00	10.60	4-3V	57	1.20	5.00	6.00	4-3V
25	4.50	3.15	14.00	5-3V	81	1.40	11.00	15.40	3-B	19	3.53	3.00	10.60	4-A	57	1.21	4.80	5.80	4-B
25	4.50	4.00	18.00	4-A	82	1.38	5.00	6.90	6-3V	20	3.40	3.15	10.60	5-3V	58	1.19	5.40	6.40	4-B
26	4.31	5.80	25.00	3-B	82	1.38	6.80	9.40	4-B	20	3.35	4.60	15.40	3-B	59	1.15	6.00	6.90	4-3V
27	4.26	4.50	19.00	4-3V	84	1.36	9.25	12.50	3-5V	21	3.20	3.35	10.60	4-3V	59	1.16	7.40	8.60	3-B
27	4.29	4.20	18.00	5-A	84	1.36	5.00	6.80	6-B	21	3.33	3.60	12.00	4-A	60	1.13	5.30	6.00	5-3V
28	4.03	4.75	19.00	3-3V	85	1.34	6.00	8.00	5-3V	22	3.13	4.50	14.00	3-3V	60	1.14	5.60	6.40	4-B
28	4.09	4.40	18.00	4-A	85	1.34	6.40	8.60	4-B	22	3.16	3.80	12.00	4-A	61	1.13	7.10	8.00	3-5V
30	3.83	5.00	19.00	3-3V	86	1.33	8.00	10.60	4-3V	23	2.93	3.65	10.60	4-3V	61	1.13	4.80	5.40	5-B
30	3.75	4.80	18.00	4-A	86	1.32	9.40	12.40	3-B	23	2.94	3.60	10.60	4-A	62	1.11	5.60	6.20	4-B
31	3.61	5.30	19.00	3-3V	88	1.29	8.00	10.30	3-5V	24	2.82	5.00	14.00	3-3V	63	1.08	6.00	6.50	4-3V
31	3.68	5.00	18.40	3-B	88	1.29	7.00	9.00	5-A	24	2.87	6.40	18.40	2-B	63	1.09	8.60	9.40	3-B
32	3.54	5.20	18.40	3-B	89	1.27	7.10	9.00	3-5V	25	2.69	3.00	8.00	5-3V	64	1.06	6.50	6.90	4-3V
34	3.35	4.60	15.40	4-B	89	1.27	7.40	9.40	4-B	25	2.70	4.60	12.40	3-B	64	1.07	5.80	6.20	4-B
35	3.26	4.60	15.00	4-A	90	1.27	4.75	6.00	8-3V	26	2.59	4.12	10.60	3-3V	65	1.06	7.10	7.50	3-5V
36	3.13	4.50	14.00	4-3V	90	1.26	6.80	8.60	5-B	26	2.65	4.00	10.60	4-A	65	1.06	8.50	9.00	3-C
36	3.12	4.80	15.00	4-A	91	1.25	5.60	7.00	6-A	27	2.51	5.60	14.00	3-3V	66	1.03	5.80	6.00	4-B
37	3.08	5.00	15.40	3-B	93	1.23	5.30	6.50	6-3V	27	2.50	4.80	12.00	4-A	68	1.00	6.50	6.50	4-3V
39	2.94	6.50	19.00	3-3V	93	1.22	5.40	6.60	5-B	28	2.48	5.00	12.40	3-B	68	1.00	5.80	5.80	4-B
39	2.88	5.20	15.00	4-A	94	1.21	8.50	10.30	3-5V	29	2.37	4.50	10.60	4-3V	71	0.97	6.00	5.80	4-B

Note: These V-belts drives are designed for average service and are based on reducer ratings. Where fire hazards are prevalent and fire prevention laws apply, it is recommended that drives be redesigned using a service factor of 2.0 on the hp rating of the motor - refer to V-belt drive tables or consult DODGE

* DODGE stock sheaves, outside diameters shown for DYNA-V (3V); pitch diameters for A & B sheaves. All ratios based on P.D. Sheaves in shaded area represent speed up drives.

FEATURES/BENEFITS PAGE G2-3	NOMENCLATURE PAGE G2-11	SELECTION/DIMENSIONS PAGE G2-144	RELATED PRODUCTS PAGE G2-152
--------------------------------	----------------------------	-------------------------------------	---------------------------------

RELATED PRODUCTS



Gearing Reference Guide

TORQUE-ARM Shaft Mount Speed Reducers

V-BELT DRIVES FOR TXT515B, TXT525B & SCXT515B, SCXT525B REDUCERS 3VX, 5VX, 8VX, AX, BX, CX AND DX BELTS REQUIRED (con't)

These are typical drives for average service conditions. For other conditions, output speeds or motor speeds see reducer specification for minimum driven sheave diameter and use V-belt selection tables

Size 515B Driven by 1750 RPM Motors									Size 525B Driven by 1750 RPM Motors										
Out-put RPM	V-belt Drive Ratio	Sheave Diameters *		Qty & Belt Size	Out-put RPM	V-belt Drive Ratio	Sheave Diameters *		Qty & Belt Size	Out-put RPM	V-belt Drive Ratio	Sheave Diameters *		Qty & Belt Size	Out-put RPM	V-belt Drive Ratio	Sheave Diameters *		Qty & Belt Size
40	2.82	5.00	14.00	4-3V	94	1.21	5.60	6.80	6-B	29	2.38	5.20	12.40	3-B	72	0.95	7.50	7.10	3-5V
40	2.85	5.40	15.40	4-B	95	1.20	7.50	9.00	3-5V	31	2.20	5.00	11.00	3-B	72	0.94	9.00	8.50	3-C
42	2.70	4.60	12.40	5-B	95	1.19	6.20	7.40	5-B	32	2.13	5.00	10.60	3-3V	74	0.92	6.50	6.00	4-3V
43	2.66	5.30	14.00	4-3V	97	1.17	9.40	11.00	4-B	32	2.12	5.20	11.00	3-B	74	0.93	5.80	5.40	5-B
43	2.66	5.80	15.40	4-B	99	1.15	6.00	6.90	6-3V	33	2.07	5.80	12.00	3-A	75	0.91	6.60	6.00	4-B
44	2.58	4.80	12.40	4-B	99	1.14	5.60	6.40	6-B	34	2.01	5.30	10.60	3-3V	76	0.90	6.00	5.40	4-B
46	2.48	6.20	15.40	3-B	100	1.13	5.30	6.00	8-3V	34	2.04	5.40	11.00	3-B	77	0.89	8.00	7.10	3-5V
47	2.41	6.40	15.40	3-B	100	1.13	6.00	6.80	6-B	35	1.95	4.12	8.00	4-3V	77	0.89	7.40	6.60	4-B
48	2.37	4.50	10.60	5-3V	102	1.11	9.25	10.30	3-5V	35	1.96	4.80	9.40	3-B	78	0.88	8.60	7.50	3-5V
48	2.38	5.20	12.40	4-B	102	1.11	5.40	6.00	6-B	36	1.90	5.60	10.60	3-3V	78	0.88	6.40	5.60	5-B
49	2.33	6.60	15.40	3-B	103	1.11	9.50	10.50	3-C	36	1.88	5.00	9.40	3-B	79	0.86	8.00	6.90	4-3V
51	2.24	4.75	10.60	5-3V	104	1.09	8.50	9.25	3-5V	37	1.83	5.80	10.60	3-A	79	0.86	7.40	6.40	4-B
51	2.21	5.60	12.40	4-B	104	1.10	6.20	6.80	5-B	38	1.79	4.50	8.00	4-3V	80	0.85	11.00	9.40	3-B
52	2.20	5.00	11.00	4-B	105	1.08	6.00	6.50	6-3V	38	1.79	4.80	8.60	3-B					
53	2.13	5.00	10.60	4-3V	105	1.08	12.00	13.00	3-C	39	1.75	8.00	14.00	2-3V					
53	2.14	5.80	12.40	4-B	107	1.06	6.50	6.90	5-3V	39	1.74	5.40	9.40	3-B					
54	2.12	5.20	11.00	4-B	107	1.06	6.20	6.60	5-B	40	1.69	4.75	8.00	4-3V					
55	2.07	5.80	12.00	4-A	110	1.03	6.20	6.40	5-B	40	1.72	5.00	8.60	3-B					
57	2.01	5.30	10.60	4-3V	111	1.03	9.00	9.25	3-5V	41	1.68	4.12	6.90	4-3V					
57	2.00	6.20	12.40	3-B	117	0.97	9.25	9.00	3-5V	41	1.68	7.40	12.40	2-B					
58	1.96	5.60	11.00	4-B	117	0.97	6.40	6.20	5-B	42	1.64	6.50	10.60	3-3V					
59	1.94	6.40	12.40	4-B	119	0.95	10.50	10.00	3-C	42	1.62	6.80	11.00	3-B					
60	1.90	5.60	10.60	5-3V	120	0.94	9.00	8.50	3-5V	44	1.54	4.50	6.90	5-3V					
60	1.90	5.80	11.00	4-B	120	0.94	9.00	8.50	3-C	44	1.57	6.00	9.40	3-B					
62	1.83	6.00	11.00	4-B	122	0.93	6.00	5.60	6-3V	45	1.51	5.30	8.00	4-3V					
63	1.80	10.60	19.00	3-3V	122	0.93	6.00	5.60	6-B	45	1.52	6.20	9.40	3-B					
63	1.79	4.80	8.60	5-B	123	0.92	6.50	6.00	6-3V	46	1.48	5.00	7.40	4-B					
65	1.75	8.00	14.00	3-3V	123	0.92	13.00	12.00	3-C	47	1.45	4.50	6.50	5-3V					
65	1.74	5.40	9.40	5-B	124	0.92	9.25	8.50	3-5V	47	1.47	6.40	9.40	3-B					
66	1.72	6.40	11.00	4-B	124	0.91	9.40	8.60	4-B	48	1.43	5.60	8.00	4-3V					

Note: These V-belts drives are designed for average service and are based on reducer ratings. Where fire hazards are prevalent and fire prevention laws apply, it is recommended that drives be redesigned using a service factor of 2.0 on the hp rating of the motor - refer to V-belt drive tables or consult DODGE

* DODGE stock sheaves, outside diameters shown for DYNA-V (3V); pitch diameters for A & B sheaves. All ratios based on P.D. Sheaves in shaded area represent speed up drives.

TORQUE-ARM II

TORQUE-ARM

MAXIMUM Concentric Reducer

TIGEAR-2

FEATURES/BENEFITS PAGE G2-3	NOMENCLATURE PAGE G2-11	SELECTION/DIMENSIONS PAGE G2-144	RELATED PRODUCTS PAGE G2-152
--------------------------------	----------------------------	-------------------------------------	---------------------------------

RELATED PRODUCTS



TORQUE-ARM Shaft Mount Speed Reducers V-BELT DRIVES FOR TXT615, TXT625 & SCXT615, SCXT625 REDUCERS 3VX, 5VX, 8VX, AX, BX, CX AND DX BELTS REQUIRED

These are typical drives for average service conditions, For other conditions, output speeds or motor speeds see reducer specification for minimum driven sheave diameter and use V-belt selection tables

Size 615 Driven by 1750 RPM Motors									Size 625 Driven by 1750 RPM Motors										
Out-put RPM	V-belt Drive Ratio	Sheave Diameters *		Qty & Belt Size	Out-put RPM	V-belt Drive Ratio	Sheave Diameters *		Qty & Belt Size	Out-put RPM	V-belt Drive Ratio	Sheave Diameters *		Qty & Belt Size					
10	11.34	3.00	33.50	4-3V	68	1.68	7.50	12.50	3-5V	10	6.93	3.65	25.00	3-3V	51	1.37	4.75	6.50	8-3V
11	10.79	3.15	33.50	4-3V	68	1.67	6.60	11.00	5-B	11	6.11	3.15	19.00	3-3V	51	1.37	5.40	7.40	5-B
12	9.29	3.65	33.50	4-3V	69	1.66	8.00	13.20	3-5V	11	6.52	4.60	30.00	3-B	52	1.34	6.00	8.00	5-3V
13	8.46	3.00	25.00	5-3V	69	1.66	6.40	10.60	8-A	12	5.74	3.35	19.00	4-3V	52	1.34	6.40	8.60	4-B
15	7.56	3.35	25.00	4-3V	71	1.62	6.80	11.00	5-B	12	5.63	3.20	18.00	5-A	54	1.29	8.00	10.30	3-5V
15	7.60	5.00	38.00	3-B	72	1.58	7.50	11.80	3-5V	14	5.04	5.00	25.00	3-3V	54	1.28	5.00	6.40	6-B
16	7.31	5.20	38.00	3-B	72	1.59	5.40	8.60	6-B	14	5.00	3.60	18.00	5-A	55	1.27	7.10	9.00	3-5V
17	6.79	5.60	38.00	3-B	73	1.57	8.00	12.50	3-5V	15	4.66	4.12	19.00	3-3V	55	1.26	6.80	8.60	4-B
18	6.25	4.80	30.00	4-B	73	1.57	6.00	9.40	5-B	15	4.74	3.80	18.00	4-A	56	1.23	6.50	8.00	5-3V
20	5.61	4.50	25.00	4-3V	74	1.54	6.90	10.60	5-3V	16	4.23	3.35	14.00	4-3V	56	1.23	6.00	7.40	5-B
20	5.77	5.20	30.00	3-B	74	1.54	5.60	8.60	6-B	16	4.29	4.20	18.00	4-A	57	1.23	5.30	6.50	6-3V
21	5.43	4.60	25.00	4-B	75	1.51	5.30	8.00	8-3V	17	4.03	4.75	19.00	3-3V	57	1.22	5.40	6.60	5-V
22	5.21	4.80	25.00	4-B	75	1.52	6.20	9.40	5-B	17	4.09	4.40	18.00	4-A	58	1.20	7.50	9.00	3-5V
23	5.04	5.00	25.00	3-3V	76	1.50	12.00	18.00	4-A	18	3.83	5.00	19.00	3-3V	58	1.19	6.20	7.40	5-B
23	5.00	5.00	25.00	3-B	77	1.48	8.00	11.80	3-5V	18	3.91	4.60	18.00	4-A	60	1.16	5.60	6.50	6-3V
24	4.75	5.30	25.00	3-3V	77	1.49	7.40	11.00	4-B	19	3.61	5.30	19.00	3-3V	60	1.16	7.40	8.60	4-B
24	4.74	3.80	18.00	5-A	79	1.44	9.75	14.00	3-5V	19	3.68	5.00	18.40	3-B	61	1.14	7.50	8.50	3-5V
25	4.50	5.60	25.00	4-3V	79	1.44	8.60	12.40	4-B	21	3.26	4.60	15.00	4-A	61	1.14	5.60	6.40	6-B
25	4.63	5.40	25.00	4-B	80	1.43	5.60	8.00	6-3V	22	3.13	4.50	14.00	4-3V	62	1.13	8.00	9.00	3-5V
26	4.35	4.60	20.00	5-B	80	1.43	6.00	8.60	5-B	22	3.12	4.80	15.00	4-A	62	1.13	11.00	12.40	3-B
27	4.26	4.50	19.00	5-3V	81	1.42	10.60	15.00	6-A	23	2.97	4.75	14.00	4-3V	63	1.10	6.20	6.80	5-B
27	4.17	4.80	20.00	5-B	82	1.39	8.50	11.80	3-5V	23	3.08	5.00	15.40	3-B	64	1.08	6.00	6.50	6-3V
29	4.00	4.60	18.40	5-B	82	1.40	11.00	15.40	4-B	24	2.94	6.50	19.00	3-3V	64	1.09	8.60	9.40	4-B
30	3.83	5.00	19.00	4-3V	83	1.38	7.10	9.75	4-5V	24	2.96	5.20	15.40	3-B	65	1.07	7.50	8.00	3-5V
30	3.75	4.80	18.00	5-A	83	1.38	6.80	9.40	6-B	25	2.82	5.00	14.00	3-3V	65	1.06	6.20	6.60	5-B
31	3.64	6.90	25.00	3-3V	85	1.34	6.00	8.00	8-3V	25	2.75	5.60	15.40	3-B	66	1.06	6.50	6.90	5-3V
31	3.68	5.00	18.40	4-B	85	1.34	6.40	8.60	6-B	26	2.66	5.30	14.00	4-3V	67	1.03	6.20	6.40	5-B
32	3.61	5.30	19.00	4-3V	86	1.33	8.00	10.60	5-3V	26	2.66	5.80	15.40	4-B	68	1.03	9.00	9.25	3-5V
32	3.54	5.20	18.40	4-B	86	1.33	9.00	12.00	6-A	27	2.58	4.80	12.40	4-B	68	1.03	6.40	6.60	5-B
33	3.41	5.60	19.00	4-3V	87	1.31	9.00	11.80	3-5V	28	2.51	5.60	14.00	4-3V	70	1.00	6.00	6.00	6-3V
33	3.41	5.40	18.40	4-B	87	1.32	9.40	12.40	5-B	28	2.48	6.20	15.40	3-B	70	1.00	11.00	11.00	3-B
34	3.35	4.60	15.40	5-B	88	1.30	7.50	9.75	4-5V	30	2.34	6.00	14.00	4-3V	72	0.97	9.25	9.00	3-5V
35	3.29	5.60	18.40	4-B	88	1.30	10.00	13.00	3-C	30	2.29	4.80	11.00	4-B	72	0.97	6.40	6.20	5-B
37	3.07	6.00	18.40	4-B	89	1.28	9.25	11.80	3-5V	31	2.24	4.75	10.60	5-3V	73	0.95	9.75	9.25	3-5V
38	2.97	4.75	14.00	6-3V	89	1.28	8.60	11.00	5-B	31	2.26	6.80	15.40	3-B	73	0.95	10.00	9.50	3-C
38	2.97	6.20	18.40	4-B	91	1.25	12.00	15.00	5-A	32	2.16	6.50	14.00	3-3V	74	0.94	6.90	6.50	5-3V
39	2.94	6.50	19.00	4-3V	92	1.24	7.50	9.25	4-5V	32	2.20	5.00	11.00	4-B	74	0.94	6.40	6.00	5-B
39	2.96	5.20	15.40	5-B	92	1.24	12.40	15.40	4-B	33	2.13	5.00	10.60	4-3V	75	0.92	6.50	6.00	6-3V

Note: These V-belts drives are designed for average service and are based on reducer ratings. Where fire hazards are prevalent and fire prevention laws apply, it is recommended that drives be redesigned using a service factor of 2.0 on the hp rating of the motor - refer to V-belt drive tables or consult DODGE

* DODGE stock sheaves, outside diameters shown for DYNA-V (3V); pitch diameters for A & B sheaves. All ratios based on P.D. Sheaves in shaded area represent speed up drives.

FEATURES/BENEFITS PAGE G2-3	NOMENCLATURE PAGE G2-11	SELECTION/DIMENSIONS PAGE G2-144	RELATED PRODUCTS PAGE G2-152
--------------------------------	----------------------------	-------------------------------------	---------------------------------

RELATED PRODUCTS



Gearing Reference Guide

TORQUE-ARM Shaft Mount Speed Reducers V-BELT DRIVES FOR TXT615, TXT625 & SCXT615, SCXT625 REDUCERS 3VX, 5VX, 8VX, AX, BX, CX AND DX BELTS REQUIRED (con't)

These are typical drives for average service conditions, For other conditions. output speeds or motor speeds see reducer specification for minimum driven sheave diameter and use V-belt selection tables

Size 615 Driven by 1750 RPM Motors									Size 625 Driven by 1750 RPM Motors										
Out-put RPM	V-belt Drive Ratio	Sheave Diameters *		Qty & Belt Size	Out-put RPM	V-belt Drive Ratio	Sheave Diameters *		Qty & Belt Size	Out-put RPM	V-belt Drive Ratio	Sheave Diameters *		Qty & Belt Size	Out-put RPM	V-belt Drive Ratio	Sheave Diameters *		Qty & Belt Size
40	2.82	5.00	14.00	5-3V	93	1.23	6.50	8.00	8-3V	33	2.12	5.20	11.00	4-B	76	0.92	9.25	8.50	3-5V
40	2.87	6.40	18.40	4-B	93	1.23	6.00	7.40	8-B	34	2.04	6.90	14.00	3-3V	76	0.91	6.80	6.20	5-B
41	2.77	6.90	19.00	4-3V	94	1.21	9.00	10.90	3-5V	34	2.04	5.40	11.00	4-B	77	0.91	6.60	6.00	5-B
41	2.79	6.60	18.40	4-B	94	1.21	7.00	8.50	5-C	36	1.96	4.80	9.40	5-B	78	0.89	9.00	8.00	3-5V
42	2.71	6.80	18.40	4-B	95	1.20	7.10	8.50	4-5V	37	1.90	5.60	10.60	5-3V	78	0.89	7.40	6.60	5-B
44	2.57	6.00	15.40	4-B	95	1.20	10.00	12.00	3-C	37	1.90	5.80	11.00	4-B	79	0.89	8.00	7.10	3-5V
45	2.51	5.60	14.00	5-3V	96	1.19	11.80	14.00	3-5V	38	1.83	6.00	11.00	4-B	79	0.88	6.80	6.00	5-B
45	2.53	9.50	24.00	3-C	96	1.19	8.00	9.50	4-C	39	1.77	6.00	10.60	4-3V	80	0.87	6.90	6.00	5-3V
46	2.49	7.40	18.40	4-B	98	1.16	6.90	8.00	6-3V	39	1.77	6.20	11.00	4-B	80	0.88	8.00	7.00	4-C
47	2.41	6.40	15.40	5-B	98	1.16	7.40	8.60	5-B	40	1.75	8.00	14.00	3-3V					
48	2.38	8.00	19.00	4-3V	99	1.15	6.00	6.90	8-3V	40	1.72	5.00	8.60	5-B					
48	2.38	5.20	12.40	6-B	99	1.16	6.40	7.40	6-B	42	1.67	7.10	11.80	3-5V					
49	2.34	6.00	14.00	5-3V	100	1.15	9.00	10.30	3-5V	42	1.68	7.40	12.40	3-B					
49	2.33	6.60	15.40	4-B	100	1.14	10.50	12.00	3-C	43	1.61	5.00	8.00	5-3V					
51	2.24	4.75	10.60	8-3V	101	1.13	7.10	8.00	4-5V	43	1.62	5.80	9.40	4-B					
51	2.25	8.00	18.00	3-C	101	1.13	11.00	12.40	4-B	44	1.58	7.50	11.80	3-5V					
52	2.21	5.60	12.40	5-B	103	1.11	9.00	10.00	4-C	44	1.57	6.00	9.40	4-B					
53	2.16	6.50	14.00	5-3V	104	1.09	8.60	9.40	5-B	45	1.54	6.90	10.60	4-3V					
53	2.14	5.80	12.40	5-B	105	1.08	10.90	11.80	3-5V	45	1.54	5.60	8.60	4-B					
54	2.13	5.00	10.60	6-3V	105	1.09	11.00	12.00	4-C	46	1.51	5.30	8.00	6-3V					
54	2.12	5.20	11.00	6-B	106	1.07	14.00	15.00	3-5V	46	1.52	6.20	9.40	5-B					
55	2.07	6.00	12.40	5-B	106	1.08	13.00	14.00	3-C	48	1.46	4.75	6.90	8-3V					
56	2.04	6.90	14.00	4-3V	107	1.06	8.00	8.50	4-5V	48	1.44	8.60	12.40	4-B					
56	2.04	5.40	11.00	5-B	107	1.07	7.50	8.00	5-C	49	1.43	5.60	8.00	5-3V					
58	1.95	10.90	21.20	3-5V	109	1.05	10.00	10.50	4-C	49	1.42	6.60	9.40	4-B					
58	1.96	5.60	11.00	6-B	111	1.03	9.00	9.25	4-5V	50	1.38	5.00	6.90	6-3V					
59	1.94	6.40	12.40	5-B	114	1.00	10.60	10.60	5-3V	50	1.38	6.80	9.40	4-B					
60	1.90	5.60	10.60	6-3V	114	1.00	9.40	9.40	5-B										
60	1.89	9.50	18.00	3-C	117	0.97	9.25	9.00	4-5V										
61	1.88	7.50	14.00	3-5V	121	0.94	10.90	10.30	3-5V										
61	1.88	6.60	12.40	5-B	121	0.94	6.80	6.40	8-B										
62	1.83	6.00	11.00	6-B	122	0.94	8.00	7.50	5-5V										
63	1.82	6.80	12.40	5-B	122	0.94	8.00	7.50	5-C										
64	1.77	6.00	10.60	6-3V	123	0.93	14.00	13.00	3-C										
64	1.77	6.20	11.00	5-B	124	0.92	11.80	10.90	3-5V										
66	1.74	9.25	16.00	3-5V	124	0.92	7.40	6.80	8-B										
66	1.72	6.40	11.00	5-B															
67	1.71	7.00	12.00	6-A															

Note: These V-belts drives are designed for average service and are based on reducer ratings. Where fire hazards are prevalent and fire prevention laws apply, it is recommended that drives be redesigned using a service factor of 2.0 on the hp rating of the motor - refer to V-belt drive tables or consult DODGE

* DODGE stock sheaves. outside diameters shown for DYNA-V (3V); pitch diameters for A & B sheaves. All ratios based on P.D. Sheaves in shaded area represent speed up drives.

FEATURES/BENEFITS PAGE G2-3	NOMENCLATURE PAGE G2-11	SELECTION/DIMENSIONS PAGE G2-144	RELATED PRODUCTS PAGE G2-152
--------------------------------	----------------------------	-------------------------------------	---------------------------------

TORQUE-ARM II

TORQUE-ARM

MAXIMUM Concentric Reducer

TIGEAR-2

RELATED PRODUCTS



TORQUE-ARM Shaft Mount Speed Reducers V-BELT DRIVES FOR TXT715, TXT725 & SCXT715, SCXT725 REDUCERS 3VX, 5VX, 8VX, AX, BX, CX AND DX BELTS REQUIRED

These are typical drives for average service conditions, For other conditions. output speeds or motor speeds see reducer specification for minimum driven sheave diameter and use V-belt selection tables

Size 715 Driven by 1750 RPM Motors									Size 725 Driven by 1750 RPM Motors										
Out-put RPM	V-belt Drive Ratio	Sheave Diameters *		Qty & Belt Size	Out-put RPM	V-belt Drive Ratio	Sheave Diameters *		Qty & Belt Size	Out-put RPM	V-belt Drive Ratio	Sheave Diameters *		Qty & Belt Size	Out-put RPM	V-belt Drive Ratio	Sheave Diameters *		Qty & Belt Size
10	11.34	3.00	33.50	5-3V	63	1.82	6.80	12.40	6-B	10	6.93	3.65	25.00	4-3V	49	1.46	7.50	10.90	3-5V
10	11.34	3.00	33.50	5-3V	65	1.75	8.00	14.00	6-3V	10	7.31	5.20	38.00	3-B	49	1.44	8.60	12.40	4-B
14	8.22	4.12	33.50	4-3V	65	1.78	9.00	16.00	4-C	11	6.52	4.60	30.00	4-B	50	1.43	9.25	13.20	3-5V
14	8.26	4.60	38.00	4-B	67	1.71	7.00	12.00	6-C	12	6.13	4.12	25.00	4-3V	50	1.43	6.00	8.60	8-B
16	7.31	5.20	38.00	3-B	68	1.70	12.50	21.20	3-5V	12	6.00	5.00	30.00	3-B	51	1.39	8.50	11.80	3-5V
17	6.76	5.00	33.50	4-3V	68	1.68	9.50	16.00	4-C	13	5.31	4.75	25.00	3-3V	51	1.40	11.00	15.40	4-B
17	6.79	5.60	38.00	4-B	69	1.66	8.00	13.20	4-5V	13	5.43	4.60	25.00	4-B	52	1.38	7.10	9.75	4-5V
18	6.37	5.30	33.50	4-3V	69	1.67	11.00	18.40	5-B	14	5.04	5.00	25.00	3-3V	52	1.36	7.00	9.50	5-C
18	6.25	4.80	30.00	5-B	70	1.65	9.75	16.00	3-5V	14	5.00	5.00	25.00	3-B	53	1.34	6.00	8.00	8-3V
20	5.61	4.50	25.00	5-3V	70	1.64	9.40	15.40	5-B	15	4.66	4.12	19.00	4-3V	53	1.34	6.40	8.60	6-B
20	5.77	5.20	30.00	4-B	72	1.60	7.50	12.00	5-C	15	4.74	3.80	18.00	5-A	54	1.33	8.00	10.60	5-3V
21	5.43	4.60	25.00	5-B	73	1.57	8.00	12.50	4-5V	16	4.50	5.60	25.00	3-3V	54	1.32	9.40	12.40	5-B
22	5.31	4.75	25.00	5-3V	73	1.57	7.00	11.00	6-C	16	4.50	4.00	18.00	5-A	56	1.28	9.25	11.80	3-5V
22	5.17	5.80	30.00	5-B	75	1.54	6.90	10.60	8-3V	17	4.26	4.50	19.00	5-3V	56	1.27	7.40	9.40	5-B
23	5.04	5.00	25.00	5-3V	75	1.54	13.00	20.00	3-C	17	4.17	4.80	20.00	5-B	57	1.24	12.40	15.40	4-B
23	5.00	5.00	25.00	5-B	76	1.52	9.25	14.00	4-5V	18	4.03	4.75	19.00	4-3V	58	1.23	6.50	8.00	8-3V
25	4.63	5.40	25.00	5-B	77	1.49	7.40	11.00	6-B	18	4.00	4.60	18.40	5-B	58	1.23	6.00	7.40	8-B
26	4.50	5.60	25.00	5-3V	78	1.48	8.00	11.80	4-5V	20	3.61	5.30	19.00	4-3V	59	1.21	9.00	10.90	3-5V
26	4.46	5.60	25.00	5-B	78	1.47	7.50	11.00	5-C	20	3.54	5.20	18.40	4-B	59	1.20	10.00	12.00	3-C
27	4.19	6.00	25.00	4-3V	79	1.46	10.30	15.00	3-5V	21	3.41	5.60	19.00	4-3V	60	1.18	9.25	10.90	3-5V
27	4.31	5.80	25.00	5-B	79	1.45	11.00	16.00	4-C	21	3.41	5.40	18.40	4-B	60	1.18	9.00	10.60	6-A
29	3.99	7.10	28.00	3-5V	80	1.43	9.25	13.20	4-5V	22	3.18	6.00	19.00	4-3V	61	1.16	6.90	8.00	6-3V
29	4.00	5.00	20.00	5-B	80	1.44	8.60	12.40	6-B	22	3.29	5.60	18.40	4-B	61	1.16	7.40	8.60	5-B
30	3.83	5.00	19.00	6-3V	81	1.41	8.50	12.00	5-C	23	3.14	8.00	25.00	3-3V	62	1.15	6.00	6.90	8-3V
30	3.85	5.20	20.00	6-B	82	1.39	8.50	11.80	4-5V	23	3.07	6.00	18.40	4-B	62	1.16	6.40	7.40	6-B
31	3.68	5.00	18.40	6-B	82	1.40	11.00	15.40	5-B	24	2.94	6.50	19.00	4-3V	63	1.13	7.10	8.00	4-5V
33	3.53	8.00	28.00	3-5V	84	1.37	8.00	10.90	5-5V	24	2.97	6.20	18.40	4-B	63	1.13	11.00	12.40	4-B
33	3.45	5.80	20.00	5-B	84	1.37	9.50	13.00	5-C	25	2.82	5.00	14.00	5-3V	64	1.11	9.25	10.30	3-5V
34	3.41	5.60	19.00	6-3V	85	1.36	11.80	16.00	3-5V	25	2.87	6.40	18.40	4-B	64	1.12	8.50	9.50	4-C
34	3.41	5.40	18.40	8-B	86	1.33	7.50	10.00	6-C	26	2.77	6.90	19.00	4-3V	65	1.09	8.50	9.25	4-5V
35	3.32	8.50	28.00	3-5V	88	1.30	7.50	9.75	5-5V	26	2.79	6.60	18.40	4-B	65	1.09	8.60	9.40	6-B
35	3.29	5.60	18.40	6-B	88	1.31	8.00	10.50	5-C	27	2.66	5.30	14.00	5-3V	67	1.06	10.30	10.90	3-5V
36	3.18	6.00	19.00	6-3V	89	1.28	9.75	12.50	4-5V	27	2.66	5.80	15.40	4-B	67	1.07	7.50	8.00	5-C
36	3.19	9.40	30.00	4-B	89	1.29	8.50	11.00	5-C	30	2.34	6.00	14.00	5-3V	68	1.05	9.50	10.00	4-C
38	3.01	7.10	21.20	4-5V	91	1.27	7.50	9.50	6-C	30	2.33	6.60	15.40	4-B	69	1.03	9.00	9.25	4-5V
38	3.03	6.60	20.00	5-B	92	1.24	12.40	15.40	5-B	31	2.27	7.10	16.00	3-5V	71	1.00	10.60	10.60	5-3V
39	2.94	6.50	19.00	5-3V	93	1.24	7.50	9.25	5-5V	31	2.26	6.80	15.40	4-B	71	1.00	9.40	9.40	5-B
39	2.94	6.80	20.00	5-B	93	1.24	8.50	10.50	5-C	32	2.24	4.75	10.60	8-3V	73	0.97	9.25	9.00	4-5V

Note: These V-belts drives are designed for average service and are based on reducer ratings. Where fire hazards are prevalent and fire prevention laws apply, it is recommended that drives be redesigned using a service factor of 2.0 on the hp rating of the motor - refer to V-belt drive tables or consult DODGE

* DODGE stock sheaves. outside diameters shown for DYNA-V (3V); pitch diameters for A & B sheaves. All ratios based on P.D. Sheaves in shaded area represent speed up drives.

FEATURES/BENEFITS PAGE G2-3	NOMENCLATURE PAGE G2-11	SELECTION/DIMENSIONS PAGE G2-144	RELATED PRODUCTS PAGE G2-152
--------------------------------	----------------------------	-------------------------------------	---------------------------------

RELATED PRODUCTS



TORQUE-ARM Shaft Mount Speed Reducers

V-BELT DRIVES FOR TXT715, TXT725 & SCXT715, SCXT725 REDUCERS 3VX, 5VX, 8VX, AX, BX, CX AND DX BELTS REQUIRED (con't)

These are typical drives for average service conditions. For other conditions, output speeds or motor speeds see reducer specification for minimum driven sheave diameter and use V-belt selection tables

Size 715 Driven by 1750 RPM Motors									Size 725 Driven by 1750 RPM Motors										
Out-put RPM	V-belt Drive Ratio	Sheave Diameters *		Qty & Belt Size	Out-put RPM	V-belt Drive Ratio	Sheave Diameters *		Qty & Belt Size	Out-put RPM	V-belt Drive Ratio	Sheave Diameters *		Qty & Belt Size	Out-put RPM	V-belt Drive Ratio	Sheave Diameters *		Qty & Belt Size
41	2.79	6.60	18.40	5-B	94	1.22	8.00	9.75	5-5V	32	2.21	5.60	12.40	5-B	75	0.94	10.90	10.30	3-5V
42	2.77	6.90	19.00	5-3V	94	1.22	9.00	11.00	5-C	33	2.13	5.00	10.60	6-3V	75	0.95	9.50	9.00	4-C
42	2.71	6.80	18.40	5-B	95	1.21	9.00	10.90	4-5V	33	2.14	5.80	12.40	5-B	76	0.94	8.50	8.00	4-5V
43	2.66	5.30	14.00	8-3V	96	1.20	7.50	9.00	5-5V	34	2.07	6.00	12.40	5-B					
43	2.70	7.40	20.00	5-B	96	1.20	10.00	12.00	4-C	35	2.04	6.90	14.00	4-3V					
46	2.51	5.60	14.00	6-3V	97	1.18	9.25	10.90	4-5V	35	2.04	5.40	11.00	5-B					
46	2.48	6.20	15.40	5-B	97	1.18	11.00	13.00	4-C	36	1.99	7.10	14.00	3-5V					
47	2.42	12.40	30.00	3-B	98	1.17	9.40	11.00	6-B	36	2.00	6.20	12.40	5-B					
48	2.38	8.00	19.00	4-3V	100	1.15	9.00	10.30	4-5V	38	1.88	7.50	14.00	3-5V					
48	2.41	6.40	15.40	5-B	101	1.14	7.50	8.50	5-5V	38	1.88	6.60	12.40	5-B					
50	2.31	9.25	21.20	3-5V	101	1.14	10.50	12.00	4-C	39	1.82	6.80	12.40	5-B					
50	2.29	10.50	24.00	3-C	102	1.12	12.50	14.00	3-5V	40	1.77	6.00	10.60	6-3V					
51	2.27	7.10	16.00	4-5V	102	1.13	11.00	12.40	5-B	40	1.77	6.20	11.00	5-B					
51	2.26	6.80	15.40	6-B	103	1.12	11.80	13.20	3-5V	41	1.75	8.00	14.00	4-3V					
52	2.20	8.20	18.00	8-A	103	1.12	8.50	9.50	5-C	41	1.72	6.40	11.00	5-B					
53	2.16	6.50	14.00	8-3V	104	1.11	9.50	10.50	5-C	42	1.68	7.50	12.50	3-5V					
53	2.18	11.00	24.00	3-C	105	1.09	11.00	12.00	5-C	42	1.68	7.40	12.40	5-B					
55	2.08	7.40	15.40	6-B	107	1.07	14.00	15.00	3-5V	43	1.66	8.00	13.20	3-5V					
56	2.04	6.90	14.00	6-3V	107	1.08	13.00	14.00	4-C	43	1.67	6.60	11.00	5-B					
56	2.07	6.00	12.40	8-B	108	1.06	10.30	10.90	4-5V	44	1.64	6.50	10.60	5-3V					
58	1.99	7.10	14.00	4-5V	109	1.05	9.25	9.75	5-5V	44	1.62	6.80	11.00	5-B					
59	1.95	10.90	21.20	3-5V	109	1.05	10.00	10.50	5-C	45	1.58	7.50	11.80	3-5V					
59	1.94	6.40	12.40	6-B	110	1.05	10.50	11.00	5-C	45	1.57	6.00	9.40	5-B					
60	1.90	10.50	20.00	3-C	112	1.03	9.00	9.25	5-5V	47	1.51	5.30	8.00	8-3V					
61	1.89	8.50	16.00	3-5V	115	1.00	10.30	10.30	4-5V	47	1.52	6.20	9.40	5-B					
61	1.88	8.50	16.00	4-C	115	1.00	11.00	11.00	6-B	48	1.48	8.00	11.80	3-5V					
62	1.86	7.00	13.00	5-C	118	0.97	9.25	9.00	5-5V	48	1.49	7.40	11.00	4-B					

Note: These V-belts drives are designed for average service and are based on reducer ratings. Where fire hazards are prevalent and fire prevention laws apply, it is recommended that drives be redesigned using a service factor of 2.0 on the hp rating of the motor - refer to V-belt drive tables or consult DODGE

* DODGE stock sheaves, outside diameters shown for DYNA-V (3V); pitch diameters for A & B sheaves. All ratios based on P.D. Sheaves in shaded area represent speed up drives.

FEATURES/BENEFITS PAGE G2-3	NOMENCLATURE PAGE G2-11	SELECTION/DIMENSIONS PAGE G2-144	RELATED PRODUCTS PAGE G2-152
--------------------------------	----------------------------	-------------------------------------	---------------------------------

RELATED PRODUCTS



TORQUE-ARM Shaft Mount Speed Reducers

V-BELT DRIVES FOR TXT815, & TXT825 REDUCERS

3VX, 5VX, 8VX, AX, BX, CX AND DX BELTS REQUIRED

These are typical drives for average service conditions, For other conditions, output speeds or motor speeds see reducer specification for minimum driven sheave diameter and use V-belt selection tables

Size 815 Driven by 1750 RPM Motors									Size 825 Driven by 1750 RPM Motors										
Out-put RPM	V-belt Drive Ratio	Sheave Diameters *		Qty & Belt Size	Out-put RPM	V-belt Drive Ratio	Sheave Diameters *		Qty & Belt Size	Out-put RPM	V-belt Drive Ratio	Sheave Diameters *		Qty & Belt Size	Out-put RPM	V-belt Drive Ratio	Sheave Diameters *		Qty & Belt Size
14	8.26	4.60	38.00	5-B	61	1.90	10.50	20.00	4-C	10	7.31	5.20	38.00	3-B	48	1.48	8.00	11.80	4-5V
15	7.52	4.50	33.50	4-3V	63	1.85	13.00	24.00	4-C	11	6.52	4.60	30.00	4-B	48	1.49	7.40	11.00	6-B
15	7.60	5.00	38.00	4-B	64	1.80	11.80	21.20	3-5V	12	6.13	4.12	25.00	4-3V	49	1.44	9.75	14.00	3-5V
16	7.12	4.75	33.50	4-3V	64	1.80	10.00	18.00	4-C	12	6.00	5.00	30.00	3-B	49	1.44	8.60	12.40	6-B
16	7.31	5.20	38.00	4-B	65	1.80	10.60	19.00	6-3V	13	5.31	4.75	25.00	4-3V	50	1.43	9.25	13.20	4-5V
18	6.37	5.30	33.50	5-3V	65	1.79	8.60	15.40	8-B	13	5.43	4.60	25.00	5-B	50	1.41	8.50	12.00	4-C
18	6.33	6.00	38.00	4-B	66	1.75	8.00	14.00	8-3V	14	5.04	5.00	25.00	4-3V	51	1.39	8.50	11.80	4-5V
19	6.03	5.60	33.50	4-3V	66	1.75	8.00	14.00	6-C	14	5.00	5.00	25.00	4-B	51	1.40	11.00	15.40	5-B
19	6.00	5.00	30.00	5-B	68	1.70	12.50	21.20	4-5V	16	4.50	5.60	25.00	4-3V	52	1.37	8.00	10.90	4-5V
20	5.77	5.20	30.00	5-B	68	1.71	10.50	18.00	5-C	16	4.35	4.60	20.00	5-B	52	1.36	7.00	9.50	6-C
21	5.62	6.00	33.50	5-3V	69	1.67	9.00	15.00	5-5V	17	4.19	6.00	25.00	4-3V	53	1.33	7.50	10.00	6-C
21	5.56	5.40	30.00	6-B	69	1.67	11.00	18.40	6-B	17	4.17	6.00	25.00	4-B	54	1.33	8.00	10.60	8-3V
22	5.31	4.75	25.00	6-3V	70	1.65	9.75	16.00	4-5V	18	4.03	4.75	19.00	5-3V	54	1.32	9.40	12.40	6-B
22	5.17	5.80	30.00	5-B	70	1.67	12.00	20.00	4-C	18	4.00	5.00	20.00	5-B	55	1.28	12.50	16.00	3-5V
24	4.75	5.30	25.00	6-3V	71	1.63	9.25	15.00	5-5V	19	3.83	5.00	19.00	4-3V	55	1.30	10.00	13.00	4-C
24	4.81	5.20	25.00	6-B	71	1.64	9.40	15.40	8-B	19	3.68	5.00	18.40	5-B	56	1.28	9.25	11.80	4-5V
25	4.63	5.40	25.00	6-B	73	1.60	10.00	16.00	5-C	20	3.61	5.30	19.00	5-3V	56	1.28	8.60	11.00	6-B
26	4.50	5.60	25.00	6-3V	74	1.56	10.30	16.00	4-5V	20	3.54	5.20	18.40	5-B	57	1.24	7.50	9.25	5-5V
26	4.46	5.60	25.00	6-B	75	1.54	9.75	15.00	5-5V	21	3.41	5.60	19.00	5-3V	57	1.24	12.40	15.40	5-B
27	4.29	7.00	30.00	4-C	75	1.54	13.00	20.00	4-C	21	3.41	5.40	18.40	6-B	58	1.22	8.00	9.75	5-5V
29	3.99	7.10	28.00	3-5V	76	1.52	9.25	14.00	5-5V	22	3.18	6.00	19.00	5-3V	58	1.24	8.50	10.50	5-C
29	4.05	7.40	30.00	5-B	76	1.52	10.50	16.00	5-C	22	3.29	5.60	18.40	5-B	59	1.21	9.00	10.90	4-5V
30	3.87	6.50	25.00	5-3V	77	1.50	12.00	18.00	4-C	23	3.14	8.00	25.00	4-3V	59	1.20	10.00	12.00	4-C
30	3.91	6.40	25.00	5-B	78	1.48	12.40	18.40	6-B	23	3.07	6.00	18.40	5-B	60	1.18	9.25	10.90	4-5V
31	3.77	7.50	28.00	3-5V	80	1.45	11.00	16.00	5-C	24	2.94	6.50	19.00	5-3V	60	1.18	8.50	10.00	5-C
31	3.79	6.60	25.00	5-B	81	1.44	9.75	14.00	4-5V	24	2.97	6.20	18.40	5-B	62	1.15	9.00	10.30	4-5V
32	3.61	5.30	19.00	8-3V	81	1.43	14.00	20.00	4-C	25	2.82	5.00	14.00	6-3V	62	1.14	10.50	12.00	4-C
32	3.57	5.60	20.00	6-B	83	1.39	9.00	12.50	5-5V	25	2.87	6.40	18.40	5-B	63	1.12	11.80	13.20	3-5V
34	3.38	7.40	25.00	6-B	83	1.40	11.00	15.40	6-B	26	2.77	6.90	19.00	5-3V	63	1.13	11.00	12.40	5-B
35	3.32	8.50	28.00	3-5V	84	1.38	10.90	15.00	4-5V	26	2.71	6.80	18.40	5-B	64	1.11	9.25	10.30	4-5V
35	3.33	6.00	20.00	8-B	84	1.38	13.00	18.00	4-C	27	2.66	5.30	14.00	8-3V	64	1.12	8.50	9.50	5-C
36	3.18	6.00	19.00	8-3V	86	1.36	9.25	12.50	5-5V	27	2.66	9.40	25.00	4-B	65	1.09	8.50	9.25	5-5V
36	3.19	9.40	30.00	5-B	87	1.33	12.00	16.00	4-C	28	2.51	5.60	14.00	6-3V	65	1.09	8.60	9.40	8-B
37	3.14	8.00	25.00	5-3V	88	1.32	10.60	14.00	8-3V	28	2.57	6.00	15.40	6-B	66	1.08	9.00	9.75	4-5V
37	3.13	6.40	20.00	8-B	88	1.32	9.40	12.40	8-B	29	2.48	6.20	15.40	5-B	66	1.08	12.00	13.00	4-C
38	3.01	7.10	21.20	4-5V	89	1.30	10.00	13.00	5-C	30	2.38	8.00	19.00	4-3V	67	1.06	11.80	12.50	3-5V
38	3.07	6.00	18.40	8-B	90	1.28	10.30	13.20	4-5V	30	2.41	6.40	15.40	5-B	67	1.06	8.50	9.00	5-C

Note: These V-belts drives are designed for average service and are based on reducer ratings. Where fire hazards are prevalent and fire prevention laws apply, it is recommended that drives be redesigned using a service factor of 2.0 on the hp rating of the motor - refer to V-belt drive tables or consult DODGE

* DODGE stock sheaves, outside diameters shown for DYNA-V (3V); pitch diameters for A & B sheaves. All ratios based on P.D. Sheaves in shaded area represent speed up drives.

FEATURES/BENEFITS PAGE G2-3	NOMENCLATURE PAGE G2-11	SELECTION/DIMENSIONS PAGE G2-144	RELATED PRODUCTS PAGE G2-152
--------------------------------	----------------------------	-------------------------------------	---------------------------------

RELATED PRODUCTS



TORQUE-ARM Shaft Mount Speed Reducers V-BELT DRIVES FOR TXT815, & TXT825 REDUCERS 3VX, 5VX, 8VX, AX, BX, CX AND DX BELTS REQUIRED (con't)

These are typical drives for average service conditions. For other conditions, output speeds or motor speeds see reducer specification for minimum driven sheave diameter and use V-belt selection tables

Size 815 Driven by 1750 RPM Motors									Size 825 Driven by 1750 RPM Motors										
Out-put RPM	V-belt Drive Ratio	Sheave Diameters *		Qty & Belt Size	Out-put RPM	V-belt Drive Ratio	Sheave Diameters *		Qty & Belt Size	Out-put RPM	V-belt Drive Ratio	Sheave Diameters *		Qty & Belt Size	Out-put RPM	V-belt Drive Ratio	Sheave Diameters *		Qty & Belt Size
40	2.89	9.75	28.00	3-5V	90	1.29	14.00	18.00	4-C	32	2.21	5.60	12.40	6-B	68	1.05	10.00	10.50	5-C
40	2.87	6.40	18.40	8-B	92	1.26	9.50	12.00	5-C	33	2.16	6.50	14.00	5-3V	69	1.03	9.00	9.25	5-5V
41	2.85	7.50	21.20	4-5V	93	1.24	12.40	15.40	6-B	33	2.14	8.60	18.40	4-B	71	1.00	10.30	10.30	4-5V
41	2.86	7.00	20.00	5-C	94	1.24	10.50	13.00	5-C	34	2.07	10.30	21.20	3-5V	71	1.00	11.00	11.00	6-B
42	2.77	6.90	19.00	6-3V	95	1.22	10.30	12.50	5-5V	34	2.08	7.40	15.40	6-B	73	0.97	9.25	9.00	5-5V
43	2.67	8.00	21.20	4-5V	96	1.21	9.00	10.90	6-5V	35	2.04	6.90	14.00	6-3V	74	0.95	11.00	10.50	5-C
43	2.70	7.40	20.00	8-B	96	1.21	12.00	14.50	5-D	35	2.02	12.40	25.00	4-B	75	0.94	10.90	10.30	4-5V
44	2.67	7.50	20.00	5-C	97	1.20	12.50	15.00	4-5V	36	1.99	7.10	14.00	4-5V	75	0.95	10.00	9.50	5-C
46	2.51	8.50	21.20	4-5V	97	1.19	13.00	15.50	5-D	36	1.96	9.40	18.40	5-B					
46	2.50	8.00	20.00	5-C	99	1.17	12.00	14.00	5-C	37	1.94	6.40	12.40	5-B					
47	2.49	7.40	18.40	8-B	101	1.15	10.30	11.80	5-5V	38	1.89	8.50	16.00	3-5V					
48	2.40	7.50	18.00	5-C	101	1.15	13.00	15.00	5-D	38	1.86	7.00	13.00	5-C					
49	2.38	8.00	19.00	6-3V	102	1.14	13.20	15.00	4-5V	39	1.80	11.80	21.20	3-5V					
49	2.35	8.50	20.00	5-C	102	1.14	10.50	12.00	6-C	39	1.82	6.80	12.40	6-B					
51	2.27	7.10	16.00	5-5V	103	1.13	11.00	12.40	10-B	40	1.77	6.00	10.60	8-3V					
51	2.27	11.00	25.00	5-B	106	1.09	11.00	12.00	6-C	40	1.79	8.60	15.40	5-B					
52	2.25	12.50	28.00	3-5V	107	1.08	10.90	11.80	5-5V	41	1.75	8.00	14.00	5-3V					
52	2.22	9.00	20.00	4-C	107	1.08	12.00	13.00	6-C	41	1.72	6.40	11.00	6-B					
53	2.19	9.75	21.20	4-5V	108	1.07	14.00	15.00	4-5V	42	1.67	9.00	15.00	3-5V					
53	2.18	11.00	24.00	4-C	108	1.08	13.00	14.00	5-C	42	1.67	11.00	18.40	4-B					
54	2.15	7.50	16.00	5-5V	109	1.06	13.20	14.00	4-5V	43	1.65	9.75	16.00	3-5V					
54	2.14	8.60	18.40	8-B	110	1.06	12.50	13.20	4-5V	43	1.64	9.40	15.40	5-B					
55	2.13	9.40	20.00	6-B	111	1.05	10.50	11.00	6-C	44	1.63	9.25	15.00	4-5V					
58	2.01	7.50	15.00	5-5V	112	1.04	13.00	13.50	5-D	44	1.60	7.50	12.00	5-C					
58	2.02	12.40	25.00	5-B	113	1.03	9.00	9.25	6-5V	45	1.57	8.00	12.50	4-5V					
59	1.95	10.90	21.20	4-5V	116	1.00	14.00	14.00	8-3V	45	1.57	7.00	11.00	6-C					
59	1.96	9.40	18.40	6-B	116	1.00	10.50	10.50	6-C	47	1.52	9.25	14.00	4-5V					
61	1.89	8.50	16.00	4-5V	119	0.97	9.25	9.00	6-5V	47	1.50	12.00	18.00	6-A					

Note: These V-belts drives are designed for average service and are based on reducer ratings. Where fire hazards are prevalent and fire prevention laws apply, it is recommended that drives be redesigned using a service factor of 2.0 on the hp rating of the motor - refer to V-belt drive tables or consult DODGE

* DODGE stock sheaves. outside diameters shown for DYNA-V (3V); pitch diameters for A & B sheaves. All ratios based on P.D. Sheaves in shaded area represent speed up drives.

FEATURES/BENEFITS PAGE G2-3	NOMENCLATURE PAGE G2-11	SELECTION/DIMENSIONS PAGE G2-144	RELATED PRODUCTS PAGE G2-152
--------------------------------	----------------------------	-------------------------------------	---------------------------------

RELATED PRODUCTS



TORQUE-ARM Shaft Mount Speed Reducers V-BELT DRIVES FOR TXT915, & TXT925 REDUCERS 3VX, 5VX, 8VX, AX, BX, CX AND DX BELTS REQUIRED

These are typical drives for average service conditions, For other conditions. output speeds or motor speeds see reducer specification for minimum driven sheave diameter and use V-belt selection tables

Size 915 Driven by 1750 RPM Motors									Size 926 Driven by 1750 RPM Motors										
Out-put RPM	V-belt Drive Ratio	Sheave Diameters *		Qty & Belt Size	Out-put RPM	V-belt Drive Ratio	Sheave Diameters *		Qty & Belt Size	Out-put RPM	V-belt Drive Ratio	Sheave Diameters *		Qty & Belt Size	Out-put RPM	V-belt Drive Ratio	Sheave Diameters *		Qty & Belt Size
16	7.04	5.40	38.00	8-B	65	1.79	9.00	16.00	6-5V	10	7.12	4.75	33.50	5-3V	44	1.54	13.00	20.00	4-C
17	6.79	5.60	38.00	6-B	67	1.74	9.25	16.00	6-5V	10	7.04	5.40	38.00	5-B	45	1.52	9.25	14.00	5-5V
18	6.37	5.30	33.50	6-3V	68	1.70	12.50	21.20	4-5V	11	6.03	5.60	33.50	4-3V	45	1.50	12.00	18.00	4-C
18	6.33	6.00	38.00	6-B	68	1.71	10.50	18.00	6-C	11	6.00	5.00	30.00	5-B	46	1.47	10.90	16.00	4-5V
19	6.03	5.60	33.50	6-3V	69	1.67	9.00	15.00	6-5V	12	5.62	6.00	33.50	5-3V	46	1.48	12.40	18.40	6-B
19	5.94	6.40	38.00	5-B	69	1.67	12.00	20.00	5-C	12	5.77	5.20	30.00	6-B	47	1.44	9.75	14.00	4-5V
20	5.76	6.60	38.00	5-B	70	1.65	9.75	16.00	5-5V	13	5.31	4.75	25.00	6-3V	47	1.45	11.00	16.00	5-C
21	5.62	6.00	33.50	8-3V	71	1.63	9.25	15.00	6-5V	13	5.17	5.80	30.00	5-B	48	1.43	9.25	13.20	5-5V
21	5.59	6.80	38.00	6-B	71	1.64	11.00	18.00	6-C	14	5.04	5.00	25.00	6-3V	48	1.43	14.00	20.00	4-C
22	5.19	6.50	33.50	6-3V	72	1.61	13.20	21.20	4-5V	14	4.81	5.20	25.00	6-B	49	1.38	10.90	15.00	4-5V
23	5.05	7.50	37.50	4-5V	72	1.61	12.40	20.00	10-B	15	4.50	5.60	25.00	6-3V	49	1.40	11.00	15.40	6-B
23	5.00	6.00	30.00	8-B	74	1.56	10.30	16.00	5-5V	15	4.46	5.60	25.00	6-B	50	1.36	14.00	19.00	5-3V
24	4.88	6.90	33.50	6-3V	75	1.54	9.75	15.00	6-5V	16	4.19	6.00	25.00	6-3V	50	1.37	9.50	13.00	5-C
24	4.80	7.50	36.00	5-C	75	1.54	13.00	20.00	5-C	16	4.17	6.00	25.00	6-B	51	1.33	12.00	16.00	4-C
25	4.69	6.40	30.00	8-B	76	1.52	14.00	21.20	5-5V	17	3.99	7.10	28.00	3-5V	52	1.32	10.60	14.00	6-3V
26	4.41	6.80	30.00	6-B	77	1.50	12.00	18.00	6-C	17	3.91	6.40	25.00	5-B	52	1.32	9.40	12.40	8-B
27	4.29	7.00	30.00	6-C	78	1.48	12.40	18.40	10-B	18	3.87	6.50	25.00	5-3V	53	1.28	10.30	13.20	4-5V
28	4.21	8.00	33.50	6-3V	79	1.47	10.90	16.00	6-5V	18	3.79	6.60	25.00	5-B	53	1.29	14.00	18.00	4-C
29	3.99	7.10	28.00	5-5V	81	1.43	14.00	20.00	6-C	19	3.61	5.30	19.00	6-3V	54	1.27	11.80	15.00	4-5V
29	4.05	7.40	30.00	8-B	84	1.38	10.90	15.00	6-5V	19	3.57	5.60	20.00	6-B	54	1.26	9.50	12.00	5-C
31	3.77	7.50	28.00	4-5V	84	1.38	13.00	18.00	6-C	20	3.41	5.60	19.00	6-3V	55	1.24	12.40	15.40	6-B
31	3.75	8.00	30.00	5-C	85	1.36	11.80	16.00	5-5V	20	3.41	5.40	18.40	6-B	56	1.22	10.30	12.50	4-5V
32	3.64	6.90	25.00	3-5V	87	1.33	12.00	16.00	6-C	21	3.19	9.40	30.00	5-B	57	1.19	11.80	14.00	4-5V
32	3.60	10.00	36.00	4-C	90	1.28	12.50	16.00	5-5V	22	3.14	8.00	25.00	5-3V	57	1.20	10.00	12.00	5-C
33	3.53	8.00	28.00	5-5V	90	1.29	14.00	18.00	6-C	22	3.07	6.00	18.40	6-B	58	1.18	9.25	10.90	5-5V
33	3.53	8.50	30.00	5-C	91	1.27	11.80	15.00	5-5V	23	2.94	6.50	19.00	6-3V	58	1.17	9.40	11.00	6-B
34	3.43	10.50	36.00	4-C	95	1.21	10.90	13.20	6-5V	23	2.94	6.80	20.00	6-B	59	1.15	10.30	11.80	5-5V
35	3.32	8.50	28.00	4-5V	96	1.20	12.50	15.00	6-5V	24	2.85	7.50	21.20	4-5V	59	1.15	13.00	15.00	5-D
35	3.33	9.00	30.00	5-C	97	1.19	11.80	14.00	6-5V	24	2.87	6.40	18.40	6-B	60	1.15	9.00	10.30	6-5V
36	3.19	9.40	30.00	6-B	101	1.14	14.00	16.00	5-5V	25	2.77	6.90	19.00	6-3V	60	1.14	10.50	12.00	6-C
37	3.14	8.00	25.00	3-5V	102	1.14	13.20	15.00	6-5V	25	2.71	6.80	18.40	6-B	61	1.12	12.50	14.00	4-5V
37	3.16	9.50	30.00	5-C	103	1.12	11.80	13.20	6-5V	26	2.67	8.00	21.20	4-5V	61	1.13	11.00	12.40	8-B
38	3.05	9.25	28.00	4-5V	107	1.08	10.90	11.80	6-5V	26	2.66	9.40	25.00	5-B	63	1.08	10.90	11.80	5-5V
38	3.06	12.40	38.00	5-B	108	1.07	14.00	15.00	5-5V	27	2.51	8.50	21.20	4-5V	63	1.08	13.00	14.00	5-C
39	3.00	8.00	24.00	6-C	109	1.06	11.80	12.50	6-5V	27	2.49	7.40	18.40	6-B	64	1.06	10.30	10.90	5-5V

Note: These V-belts drives are designed for average service and are based on reducer ratings. Where fire hazards are prevalent and fire prevention laws apply, it is recommended that drives be redesigned using a service factor of 2.0 on the hp rating of the motor - refer to V-belt drive tables or consult DODGE

* DODGE stock sheaves. outside diameters shown for DYNA-V (3V); pitch diameters for A & B sheaves. All ratios based on P.D. Sheaves in shaded area represent speed up drives.

FEATURES/BENEFITS PAGE G2-3	NOMENCLATURE PAGE G2-11	SELECTION/DIMENSIONS PAGE G2-144	RELATED PRODUCTS PAGE G2-152
--------------------------------	----------------------------	-------------------------------------	---------------------------------

RELATED PRODUCTS



TORQUE-ARM Shaft Mount Speed Reducers V-BELT DRIVES FOR TXT915, & TXT925 REDUCERS 3VX, 5VX, 8VX, AX, BX, CX AND DX BELTS REQUIRED (con't)

These are typical drives for average service conditions. For other conditions, output speeds or motor speeds see reducer specification for minimum driven sheave diameter and use V-belt selection tables

Size 915 Driven by 1750 RPM Motors									Size 926 Driven by 1750 RPM Motors										
Out-put RPM	V-belt Drive Ratio	Sheave Diameters *		Qty & Belt Size	Out-put RPM	V-belt Drive Ratio	Sheave Diameters *		Qty & Belt Size	Out-put RPM	V-belt Drive Ratio	Sheave Diameters *		Qty & Belt Size	Out-put RPM	V-belt Drive Ratio	Sheave Diameters *		Qty & Belt Size
40	2.89	9.75	28.00	4-5V	110	1.06	12.50	13.20	6-5V	28	2.40	7.50	18.00	5-C	64	1.07	13.50	14.50	5-D
40	2.91	8.60	25.00	6-B	116	1.00	11.80	11.80	6-5V	29	2.38	8.00	19.00	6-3V	65	1.06	12.50	13.20	4-5V
41	2.85	13.20	37.50	4-5V						29	2.33	8.60	20.00	6-B	65	1.05	10.50	11.00	6-C
41	2.86	10.50	30.00	5-C						30	2.27	7.10	16.00	5-5V	66	1.03	9.00	9.25	6-5V
42	2.74	10.30	28.00	4-5V						30	2.27	11.00	25.00	5-B	66	1.04	13.00	13.50	5-D
42	2.73	11.00	30.00	6-B						31	2.19	9.75	21.20	3-5V	68	1.00	14.00	14.00	6-5V
44	2.66	9.40	25.00	10-B						31	2.22	9.00	20.00	4-C	68	1.00	10.50	10.50	6-C
45	2.58	10.90	28.00	4-5V						32	2.15	7.50	16.00	4-5V	70	0.97	9.25	9.00	6-5V
45	2.57	14.00	36.00	4-C						32	2.14	8.60	18.40	6-B	71	0.95	11.00	10.50	6-C
46	2.53	9.50	24.00	6-C						33	2.07	10.30	21.20	4-5V	72	0.95	13.20	12.50	4-5V
48	2.40	10.00	24.00	5-C						33	2.08	7.40	15.40	3-B	72	0.95	10.50	10.00	6-C
49	2.36	10.60	25.00	3-5V						34	2.01	7.50	15.00	5-5V	73	0.93	14.00	13.00	5-C
50	2.31	9.25	21.20	5-5V						34	2.02	12.40	25.00	5-B	74	0.92	9.25	8.50	6-5V
50	2.31	13.00	30.00	4-C						35	1.95	10.90	21.20	4-5V	74	0.92	13.00	12.00	5-C
51	2.25	12.50	28.00	4-5V						35	1.96	9.40	18.40	6-B	75	0.91	11.00	10.00	6-C
51	2.29	10.50	24.00	5-C						36	1.89	8.50	16.00	4-5V					
53	2.19	9.75	21.20	4-5V						36	1.90	10.50	20.00	4-C					
53	2.18	11.00	24.00	5-C						38	1.80	10.60	19.00	6-3V					
54	2.13	13.20	28.00	4-5V						38	1.79	8.60	15.40	6-B					
54	2.13	9.40	20.00	6-B						39	1.75	8.00	14.00	6-3V					
55	2.11	9.50	20.00	5-C						39	1.73	7.50	13.00	6-C					
56	2.07	10.30	21.20	4-5V						40	1.70	12.50	21.20	3-5V					
57	2.02	12.40	25.00	6-B						40	1.71	10.50	18.00	4-C					
58	2.01	14.00	28.00	3-5V						41	1.65	9.75	16.00	4-5V					
58	2.00	10.00	20.00	5-C						41	1.67	11.00	18.40	6-B					
59	1.95	10.90	21.20	5-5V						42	1.63	9.25	15.00	5-5V					
61	1.90	10.50	20.00	6-C						42	1.64	9.40	15.40	6-B					
63	1.85	13.00	24.00	5-C						43	1.60	10.00	16.00	5-C					
64	1.80	10.60	19.00	4-5V						44	1.56	10.30	16.00	4-5V					
64	1.82	11.00	20.00	6-C															

Note: These V-belts drives are designed for average service and are based on reducer ratings. Where fire hazards are prevalent and fire prevention laws apply, it is recommended that drives be redesigned using a service factor of 2.0 on the hp rating of the motor - refer to V-belt drive tables or consult DODGE

* DODGE stock sheaves, outside diameters shown for DYNA-V (3V); pitch diameters for A & B sheaves. All ratios based on P.D. Sheaves in shaded area represent speed up drives.

FEATURES/BENEFITS PAGE G2-3	NOMENCLATURE PAGE G2-11	SELECTION/DIMENSIONS PAGE G2-144	RELATED PRODUCTS PAGE G2-152
--------------------------------	----------------------------	-------------------------------------	---------------------------------

RELATED PRODUCTS



TORQUE-ARM Shaft Mount Speed Reducers V-BELT DRIVES FOR TXT1015 & TXT1024 REDUCERS 3VX, 5VX, 8VX, AX, BX, CX AND DX BELTS REQUIRED

These are typical drives for average service conditions, For other conditions. output speeds or motor speeds see reducer specification for minimum driven sheave diameter and use V-belt selection tables

Size 1015 Driven by 1750 RPM Motors								Size 1024 Driven by 1750 RPM Motors											
Out-put RPM	V-belt Drive Ratio	Sheave Diameters *		Qty & Belt Size	Out-put RPM	V-belt Drive Ratio	Sheave Diameters *		Qty & Belt Size	Out-put RPM	V-belt Drive Ratio	Sheave Diameters *		Qty & Belt Size					
16	7.13	7.10	50.00	4-5V	58	2.01	14.00	28.00	5-5V	10	7.12	4.75	33.50	6-3V	37	1.95	10.90	21.20	5-5V
17	6.74	7.50	50.00	4-5V	58	2.00	12.00	24.00	6-C	10	7.31	5.20	38.00	6-B	38	1.90	10.50	20.00	6-C
18	6.32	8.00	50.00	4-5V	59	1.95	10.90	21.20	6-5V	11	6.37	5.30	33.50	5-3V	39	1.85	13.00	24.00	5-C
18	6.29	7.00	44.00	6-C	64	1.80	11.80	21.20	6-5V	11	6.55	5.80	38.00	5-B	40	1.79	9.00	16.00	6-5V
19	5.94	8.50	50.00	4-5V	65	1.79	14.00	25.00	6-5V	12	6.03	5.60	33.50	6-3V	40	1.82	11.00	20.00	6-C
20	5.87	7.50	44.00	6-C	68	1.70	12.50	21.20	6-5V	12	5.94	6.40	38.00	5-B	41	1.74	9.25	16.00	6-5V
21	5.61	9.00	50.00	4-5V	72	1.61	13.20	21.20	6-5V	13	5.62	6.00	33.50	5-3V	42	1.70	12.50	21.20	4-5V
21	5.50	8.00	44.00	5-C	76	1.52	14.00	21.20	5-5V	13	5.36	5.60	30.00	6-B	42	1.71	10.50	18.00	6-C
22	5.34	7.10	37.50	5-5V	78	1.47	10.90	16.00	6-5V	14	5.19	6.50	33.50	5-3V	43	1.67	9.00	15.00	6-5V
22	5.14	7.40	38.00	6-B	80	1.45	12.50	18.00	5-8V	14	5.00	6.00	30.00	6-B	43	1.67	12.00	20.00	5-C
23	5.05	7.50	37.50	5-5V	84	1.37	13.20	18.00	5-8V	15	4.88	6.90	33.50	6-3V	44	1.65	9.75	16.00	5-5V
24	4.73	8.00	37.50	5-5V	85	1.36	14.00	19.00	5-8V	15	4.69	6.40	30.00	6-B	44	1.64	11.00	18.00	6-C
24	4.80	7.50	36.00	6-C	89	1.29	13.20	17.00	5-8V	16	4.41	6.80	30.00	6-B	45	1.61	13.20	21.20	4-5V
25	4.63	9.50	44.00	5-C	95	1.21	13.20	16.00	8-5V	17	4.19	6.00	25.00	6-3V	45	1.61	12.40	20.00	8-B
26	4.45	8.50	37.50	4-5V	101	1.14	13.20	15.00	6-5V	17	4.17	6.00	25.00	6-B	46	1.56	10.30	16.00	5-5V
26	4.42	8.60	38.00	6-B	108	1.07	14.00	15.00	6-5V	18	3.99	7.10	28.00	4-5V	47	1.52	9.25	14.00	6-5V
27	4.21	8.00	33.50	3-5V	109	1.06	13.20	14.00	6-5V	18	3.91	6.40	25.00	6-B	47	1.52	10.50	16.00	6-C
27	4.24	8.50	36.00	5-C	115	1.00	13.20	13.20	6-5V	19	3.77	7.50	28.00	4-5V	48	1.50	12.00	18.00	6-C
28	4.09	9.25	37.50	5-5V						19	3.75	8.00	30.00	5-C	49	1.47	10.90	16.00	6-5V
28	4.19	10.50	44.00	5-C						20	3.64	6.90	25.00	8-3V	49	1.48	12.40	18.40	8-B
29	4.02	12.50	50.00	4-5V						20	3.53	8.50	30.00	5-C	50	1.43	14.00	20.00	6-C
29	4.04	9.40	38.00	8-B						21	3.38	7.40	25.00	6-B	52	1.38	10.90	15.00	6-5V
30	3.88	9.75	37.50	4-5V						22	3.32	8.50	28.00	4-5V	52	1.38	13.00	18.00	6-C
30	3.79	9.50	36.00	6-C						22	3.33	9.00	30.00	4-C	53	1.36	11.80	16.00	5-5V
31	3.67	10.30	37.50	4-5V						23	3.14	8.00	25.00	8-3V	54	1.33	12.00	16.00	6-C
31	3.67	12.00	44.00	5-C						23	3.19	9.40	30.00	6-B	56	1.28	12.50	16.00	5-5V
32	3.60	10.00	36.00	5-C						24	3.05	9.25	28.00	4-5V	56	1.29	14.00	18.00	6-C
33	3.46	10.90	37.50	4-5V						24	3.00	8.00	24.00	6-C	57	1.27	11.80	15.00	5-5V
33	3.45	11.00	38.00	8-B						25	2.85	7.50	21.20	5-5V	58	1.24	12.40	15.40	8-B
34	3.43	10.50	36.00	5-C						25	2.91	8.60	25.00	6-B	59	1.21	10.90	13.20	6-5V
35	3.27	11.00	36.00	5-C						26	2.74	10.30	28.00	4-5V	59	1.23	13.00	16.00	6-C
36	3.17	10.60	33.50	4-5V						26	2.82	8.50	24.00	5-C	60	1.20	12.50	15.00	6-5V
36	3.19	9.40	30.00	8-B						27	2.67	8.00	21.20	5-5V	61	1.19	11.80	14.00	6-5V
37	3.13	9.00	28.00	6-5V						27	2.66	9.40	25.00	6-B	63	1.14	14.00	16.00	5-5V
37	3.14	14.00	44.00	5-C						28	2.58	10.90	28.00	4-5V	64	1.12	11.80	13.20	6-5V
38	3.05	9.25	28.00	6-5V						28	2.57	14.00	36.00	4-C	66	1.08	10.90	11.80	8-5V
38	3.00	12.00	36.00	6-C						29	2.53	9.50	24.00	6-C	67	1.07	14.00	15.00	5-5V

Note: These V-belts drives are designed for average service and are based on reducer ratings. Where fire hazards are prevalent and fire prevention laws apply, it is recommended that drives be redesigned using a service factor of 2.0 on the hp rating of the motor - refer to V-belt drive tables or consult DODGE

* DODGE stock sheaves. outside diameters shown for DYNA-V (3V); pitch diameters for A & B sheaves. All ratios based on P.D. Sheaves in shaded area represent speed up drives.

FEATURES/BENEFITS PAGE G2-3	NOMENCLATURE PAGE G2-11	SELECTION/DIMENSIONS PAGE G2-144	RELATED PRODUCTS PAGE G2-152
--------------------------------	----------------------------	-------------------------------------	---------------------------------

RELATED PRODUCTS



TORQUE-ARM Shaft Mount Speed Reducers V-BELT DRIVES FOR TXT1015 & TXT1024 REDUCERS 3VX, 5VX, 8VX, AX, BX, CX AND DX BELTS REQUIRED (con't)

These are typical drives for average service conditions. For other conditions, output speeds or motor speeds see reducer specification for minimum driven sheave diameter and use V-belt selection tables

Size 1015 Driven by 1750 RPM Motors								Size 1024 Driven by 1750 RPM Motors							
Out-put RPM	V-belt Drive Ratio	Sheave Diameters *		Qty & Belt Size	Out-put RPM	V-belt Drive Ratio	Sheave Diameters *		Qty & Belt Size	Out-put RPM	V-belt Drive Ratio	Sheave Diameters *		Qty & Belt Size	
40	2.89	9.75	28.00	5-5V						30	2.36	10.60	25.00	6-3V	
40	2.86	10.50	30.00	6-C						30	2.40	10.00	24.00	5-C	
42	2.74	10.30	28.00	5-5V						31	2.31	9.25	21.20	5-5V	
42	2.73	11.00	30.00	6-C						31	2.31	13.00	30.00	4-C	
43	2.69	14.00	37.50	4-5V						32	2.25	12.50	28.00	4-5V	
45	2.58	10.90	28.00	5-5V						32	2.29	10.50	24.00	5-C	
45	2.57	14.00	36.00	5-C						33	2.19	9.75	21.20	4-5V	
46	2.50	12.00	30.00	6-C						33	2.18	11.00	24.00	5-C	
48	2.38	11.80	28.00	5-5V						34	2.13	13.20	28.00	4-5V	
48	2.42	12.40	30.00	6-C						34	2.11	9.50	20.00	5-C	
50	2.31	13.00	30.00	6-C						35	2.07	10.30	21.20	4-5V	
51	2.25	12.50	28.00	5-5V						36	2.01	14.00	28.00	3-5V	
51	2.25	12.00	27.00	6-D						36	2.02	12.40	25.00	6-B	
54	2.13	13.20	28.00	5-5V											
54	2.14	14.00	30.00	6-C											
56	2.08	13.00	27.00	5-D											
57	2.02	12.40	25.00	6-C											

Note: These V-belts drives are designed for average service and are based on reducer ratings. Where fire hazards are prevalent and fire prevention laws apply, it is recommended that drives be redesigned using a service factor of 2.0 on the hp rating of the motor - refer to V-belt drive tables or consult DODGE

* DODGE stock sheaves, outside diameters shown for DYNA-V (3V); pitch diameters for A & B sheaves. All ratios based on P.D. Sheaves in shaded area represent speed up drives.

FEATURES/BENEFITS PAGE G2-3	NOMENCLATURE PAGE G2-11	SELECTION/DIMENSIONS PAGE G2-144	RELATED PRODUCTS PAGE G2-152
--------------------------------	----------------------------	-------------------------------------	---------------------------------



RELATED PRODUCTS

TORQUE-ARM Shaft Mount Speed Reducers

V-BELT DRIVES FOR TXT1215, TXT1225, TDT1325, TDT1425 & TDT1530 REDUCERS

3VX, 5VX, 8VX, AX, BX, CX AND DX BELTS REQUIRED

These are typical drives for average service conditions. For other conditions, output speeds or motor speeds see reducer specification for minimum driven sheave diameter and use V-belt selection tables.

TXT1215 Driven by 1750 RPM Motor					TXT1225 Driven by 1750 RPM Motor					TDT1325 Driven by 1750 RPM Motor					TDT1425 Driven by 1750 RPM Motor									
Out-put RPM	V-belt Drive Ratio	Sheave Diameters *		Qty & Belt Size	Out-put RPM	V-belt Drive Ratio	Sheave Diameters *		Qty & Belt Size	Out-put RPM	V-belt Drive Ratio	Sheave Diameters *		Qty & Belt Size	Out-put RPM	V-belt Drive Ratio	Sheave Diameters *		Qty & Belt Size					
		Driver	Driven				Driver	Driven				Driver	Driven				Driver	Driven						
21	5.61	9.00	50.00	5-5V	10	7.13	7.10	50.00	5-5V	10	6.74	7.50	50.00	5-5V	15	4.62	10.90	50.00	6-5V					
22	5.45	9.25	50.00	5-5V	11	6.74	7.50	50.00	4-5V	13	5.61	9.00	50.00	5-5V	17	4.26	11.80	50.00	6-5V					
23	5.17	9.75	50.00	4-5V	11	6.29	7.00	44.00	6-C	14	4.89	10.30	50.00	4-5V	19	3.81	13.20	50.00	6-5V					
24	4.89	10.30	50.00	5-5V	12	5.94	8.50	50.00	4-5V	15	4.62	10.90	50.00	4-5V	20	3.59	14.00	50.00	6-5V					
25	4.62	10.90	50.00	5-5V	12	5.87	7.50	44.00	6-C	17	4.20	9.00	37.50	6-5V	23	3.06	13.20	40.00	5-8V					
28	4.20	9.00	37.50	6-5V	13	5.61	9.00	50.00	4-5V	17	4.19	10.50	44.00	6-C	24	2.88	14.00	40.00	5-8V					
28	4.19	10.50	44.00	8-C	13	5.50	8.00	44.00	6-C	18	4.02	12.50	50.00	4-5V	25	2.85	13.20	37.50	6-5V					
29	4.09	9.25	37.50	6-5V	14	5.05	7.50	37.50	5-5V	19	3.81	13.20	50.00	4-5V	26	2.69	14.00	37.50	8-5V					
29	4.00	11.00	44.00	6-C	14	5.14	7.40	38.00	10-B	19	3.67	12.00	44.00	6-C	31	2.29	13.20	30.00	6-8V					
31	3.81	13.20	50.00	5-5V	15	4.73	8.00	37.50	5-5V	20	3.46	10.90	37.50	5-5V	33	2.13	13.20	28.00	8-5V					
32	3.67	12.00	44.00	8-C	15	4.80	7.50	36.00	6-C	21	3.38	13.00	44.00	6-C	35	2.01	14.00	28.00	8-5V					
33	3.59	14.00	50.00	5-5V	16	4.45	8.50	37.50	4-5V	22	3.20	11.80	37.50	5-5V	41	1.71	13.20	22.40	8-8V					
34	3.46	10.90	37.50	6-5V	16	4.42	8.60	38.00	8-B	23	3.02	12.50	37.50	5-5V	TDT1530 Driven by 1750 RPM Motor									
Out-put RPM	V-belt Drive Ratio	Sheave Diameters *		Qty & Belt Size	Out-put RPM	V-belt Drive Ratio	Sheave Diameters *		Qty & Belt Size	Out-put RPM	V-belt Drive Ratio	Sheave Diameters *		Qty & Belt Size										
35	3.38	13.00	44.00	6-C	17	4.20	9.00	37.50	5-5V	25	2.85	13.20	37.50	5-5V	14	4.06	13.20	53.00	6-8V					
37	3.20	11.80	37.50	6-5V	17	4.19	10.50	44.00	5-C	26	2.69	14.00	37.50	5-5V	15	3.81	13.20	50.00	8-5V					
39	3.02	12.50	37.50	6-5V	18	3.88	9.75	37.50	4-5V	31	2.29	13.20	30.00	5-8V	16	3.59	14.00	50.00	8-5V					
41	2.85	13.20	37.50	6-5V	18	4.04	9.40	38.00	8-B	33	2.13	13.20	28.00	6-5V	19	3.06	13.20	40.00	8-8V					
44	2.69	14.00	37.50	5-5V	19	3.67	10.30	37.50	4-5V	35	2.01	14.00	28.00	6-5V	20	2.85	13.20	37.50	10-5V					
45	2.58	10.90	28.00	6-5V	19	3.79	9.50	36.00	6-C	41	1.71	13.20	22.40	6-8V	21	2.69	14.00	37.50	10-5V					
49	2.38	11.80	28.00	6-5V	21	3.43	10.50	36.00	5-C	44	1.61	13.20	21.20	8-5V	* DODGE stock sheaves. outside diameters shown for DYNA-V (3V); pitch diameters for A & B sheaves. All ratios based on P.D. Sheaves in shaded area represent speed up drives									
54	2.16	14.00	30.00	5-8V	22	3.17	10.60	33.50	5-5V	46	1.52	13.20	20.00	6-8V										
55	2.13	13.20	28.00	6-5V	22	3.16	9.50	30.00	6-C	47	1.52	14.00	21.20	8-5V										
59	2.01	14.00	28.00	6-5V	23	3.13	9.00	28.00	5-5V	49	1.45	13.20	19.00	6-8V										
69	1.71	13.20	22.40	6-8V	23	3.06	12.40	38.00	6-B	52	1.36	14.00	19.00	6-8V										
73	1.61	13.20	21.20	8-5V	24	3.02	12.50	37.50	4-5V	55	1.29	14.00	18.00	6-8V										
77	1.52	14.00	21.20	8-5V	24	3.00	12.00	36.00	6-C	58	1.21	13.20	16.00	6-5V										
					25	2.89	9.75	28.00	5-5V	62	1.14	13.20	15.00	6-5V										
					25	2.86	10.50	30.00	6-C	66	1.07	14.00	15.00	6-5V										
					26	2.74	10.30	28.00	5-5V	67	1.06	13.20	14.00	6-5V										
					26	2.73	11.00	30.00	6-C															
					27	2.58	10.90	28.00	5-5V															
					28	2.50	12.00	30.00	6-C															
					29	2.42	12.40	30.00	8-B															

Note: These V-belts drives are designed for average service and are based on reducer ratings. Where fire hazards are prevalent and fire prevention laws apply, it is recommended that drives be redesigned using a service factor of 2.0 on the hp rating of the motor - refer to V-belt drive tables or consult DODGE

* DODGE stock sheaves. outside diameters shown for DYNA-V (3V); pitch diameters for A & B sheaves. All ratios based on P.D. Sheaves in shaded area represent speed up drives

FEATURES/BENEFITS PAGE G2-3	NOMENCLATURE PAGE G2-11	SELECTION/DIMENSIONS PAGE G2-144	RELATED PRODUCTS PAGE G2-152
--------------------------------	----------------------------	-------------------------------------	---------------------------------

RELATED PRODUCTS



TORQUE-ARM Shaft Mount Speed Reducers V-BELT DRIVES FOR TXT1215, TXT1225, TDT1325, TDT1425 & TDT1530 REDUCERS 3VX, 5VX, 8VX, AX, BX, CX AND DX BELTS REQUIRED

These are typical drives for average service conditions. For other conditions, output speeds or motor speeds see reducer specification for minimum driven sheave diameter and use V-belt selection tables.

TXT1215 Driven by 1750 RPM Motor					TXT1225 Driven by 1750 RPM Motor					TDT1325 Driven by 1750 RPM Motor					TDT1425 Driven by 1750 RPM Motor				
Out-put RPM	V-belt Drive Ratio	Sheave Diameters *		Qty & Belt Size	Out-put RPM	V-belt Drive Ratio	Sheave Diameters *		Qty & Belt Size	Out-put RPM	V-belt Drive Ratio	Sheave Diameters *		Qty & Belt Size	Out-put RPM	V-belt Drive Ratio	Sheave Diameters *		Qty & Belt Size
		Driver	Driven				Driver	Driven				Driver	Driven				Driver	Driven	
					30	2.38	11.80	28.00	5-5V										
					31	2.31	13.00	30.00	6-C										
					32	2.25	12.50	28.00	5-5V										
					32	2.25	12.00	27.00	6-D										
					33	2.13	13.20	28.00	5-5V										
					33	2.14	14.00	30.00	6-C										
					34	2.08	13.00	27.00	5-D										
					35	2.01	14.00	28.00	5-5V										
					35	2.02	12.40	25.00	8-B										
					36	1.95	10.90	21.20	6-5V										
					40	1.79	14.00	25.00	6-5V										
					42	1.70	12.50	21.20	6-5V										
					44	1.61	13.20	21.20	6-5V										
					46	1.53	12.50	19.00	5-8V										
					47	1.52	14.00	21.20	5-5V										
					48	1.47	10.90	16.00	6-5V										
					49	1.45	12.50	18.00	5-8V										
					51	1.38	10.90	15.00	6-5V										
					52	1.37	13.20	18.00	5-8V										
					55	1.29	13.20	17.00	5-8V										
					58	1.21	13.20	16.00	6-5V										
					66	1.07	14.00	15.00	6-5V										
					67	1.06	13.30	14.00	6-5V										
					71	1.00	13.20	13.20	8-5V										
					75	0.95	13.50	12.50	8-5V										

Note: These V-belts drives are designed for average service and are based on reducer ratings. Where fire hazards are prevalent and fire prevention laws apply, it is recommended that drives be redesigned using a service factor of 2.0 on the hp rating of the motor - refer to V-belt drive tables or consult DODGE

* DODGE stock sheaves, outside diameters shown for DYNA-V (3V); pitch diameters for A & B sheaves. All ratios based on P.D. Sheaves in shaded area represent speed up drives

FEATURES/BENEFITS PAGE G2-3	NOMENCLATURE PAGE G2-11	SELECTION/DIMENSIONS PAGE G2-144	RELATED PRODUCTS PAGE G2-152
--------------------------------	----------------------------	-------------------------------------	---------------------------------

RELATED PRODUCTS



TORQUE-ARM Shaft Mount Speed Reducers

V-BELT DRIVES FOR TXT105, SCXT105; TXT205, SCXT205; TXT305A, SCXT305A REDUCERS 3VX, 5VX, 8VX, AX, BX, CX AND DX BELTS REQUIRED

These are typical drives for average service conditions. For other conditions, output speeds or motor speeds see reducer specification for minimum driven sheave diameter and use V-belt selection tables.

Size 105 Driven by 1750 RPM Motor					Size 205 Driven by 1750 RPM Motor					Size 305A Driven by 1750 RPM Motor				
Output RPM	V-belt Drive Ratio	Sheave Diameters *		Qty & Belt Size	Output RPM	V-belt Drive Ratio	Sheave Diameters *		Qty & Belt Size	Output RPM	V-belt Drive Ratio	Sheave Diameters *		Qty & Belt Size
		Driver	Driven				Driver	Driven				Driver	Driven	
100	3.12	3.40	10.60	3-A	100	3.31	3.20	10.60	4-A	100	3.13	4.50	1400	3-3V
102	3.06	2.65	8.00	3-3V	104	3.20	3.35	10.60	3-3V	100	3.12	4.80	15.00	3-A
102	3.07	6.00	18.40	2-B	104	3.17	5.80	18.40	2-B	105	2.97	4.75	14.00	4-3V
108	2.89	2.80	8.00	3-3V	112	2.97	4.75	14.00	3-3V	105	2.97	6.20	18.40	3-B
108	2.88	5.20	15.00	2-A	112	2.94	3.60	10.60	3-A	111	2.82	5.00	14.00	3-3V
118	2.63	2.65	6.90	3-3V	120	2.77	6.90	19.00	2-3V	111	2.81	6.40	18.00	3-A
118	2.65	4.00	10.60	2-A	120	2.75	5.60	15.40	2-B	118	2.66	5.30	14.00	3-3V
129	2.41	3.35	8.00	3-3V	129	2.56	3.15	8.00	5-3V	118	2.66	5.80	15.40	3-B
129	2.41	4.40	10.60	3-A	129	2.56	3.20	8.20	5-A	121	2.59	4.12	10.60	4-3V
134	2.32	3.00	6.90	4-3V	137	2.41	3.35	8.00	4-3V	121	2.58	4.80	12.40	3-B
134	2.33	3.00	7.00	4-A	137	2.41	4.40	10.60	4-A	124	2.51	5.60	14.00	3-3V
139	2.24	4.75	10.60	3-3V	140	2.37	4.50	10.60	3-3V	124	2.52	4.20	10.60	5-A
139	2.25	4.00	9.00	3-A	140	2.37	3.80	9.00	4-A	131	2.38	8.00	19.00	2-3V
150	2.08	3.35	6.90	3-3V	150	2.21	3.65	8.00	4-3V	131	2.38	5.20	12.40	3-B
150	2.08	7.40	15.40	2-B	150	2.21	4.80	10.60	3-A	139	2.24	4.75	10.60	3-3V
160	1.95	4.12	8.00	3-3V	159	2.08	3.15	6.50	5-3V	139	2.25	4.00	9.00	5-A
160	1.94	3.60	7.00	3-A	159	2.08	7.40	15.40	2-B	147	2.13	5.00	10.60	3-3V
166	1.88	3.00	5.60	4-3V	169	1.95	4.12	8.00	3-3V	147	2.12	5.00	10.60	4-A
166	1.88	5.00	9.40	2-B	169	1.96	4.60	9.00	3-A	156	2.01	5.30	10.60	3-3V
173	1.80	3.35	6.00	3-3V	176	1.88	3.00	5.60	5-3V	156	2.00	6.00	12.00	3-A
173	1.80	3.00	5.40	4-A	176	1.88	6.60	12.40	2-B	160	1.95	4.12	8.00	4-3V
178	1.75	8.00	14.00	2-3V	184	1.80	3.35	6.00	4-3V	160	1.96	4.80	9.40	3-B
178	1.75	3.20	5.60	4-A	184	1.80	5.00	9.00	3-A	164	1.90	5.60	10.60	3-3V
186	1.68	3.00	5.00	4-3V	197	1.68	4.12	6.90	4-3V	165	1.90	5.80	11.00	3-B
186	1.68	5.60	9.40	2-B	197	1.68	5.60	9.40	3-B	174	1.80	10.60	19.00	2-3V
196	1.59	3.35	5.30	3-3V	206	1.61	5.00	8.00	3-3V	174	1.79	4.80	8.60	3-B
196	1.59	5.40	8.60	2-B	206	1.61	4.60	7.40	4-B	178	1.75	8.00	14.00	2-3V

Note: These V-belts drives are designed for average service and are based on reducer ratings. Where fire hazards are prevalent and fire prevention laws apply, it is recommended that drives be redesigned using a service factor of 2.0 on the hp rating of the motor - refer to V-belt drive tables or consult DODGE

* DODGE stock sheaves, outside diameters shown for DYNA-V (3V); pitch diameters for A & B sheaves. All ratios based on P.D. Sheaves in shaded area represent speed up drives



TORQUE-ARM Shaft Mount Speed Reducers

V-BELT DRIVES FOR TXT105, SCXT105; TXT205, SCXT205; TXT305A, SCXT305A REDUCERS 3VX, 5VX, 8VX, AX, BX, CX AND DX BELTS REQUIRED

These are typical drives for average service conditions. For other conditions, output speeds or motor speeds see reducer specification for minimum driven sheave diameter and use V-belt selection tables.

Size 105 Driven by 1750 RPM Motor					Size 205 Driven by 1750 RPM Motor					Size 305A Driven by 1750 RPM Motor				
Output RPM	V-belt Drive Ratio	Sheave Diameters *		Qty & Belt Size	Output RPM	V-belt Drive Ratio	Sheave Diameters *		Qty & Belt Size	Output RPM	V-belt Drive Ratio	Sheave Diameters *		Qty & Belt Size
		Driver	Driven				Driver	Driven				Driver	Driven	
206	1.51	5.30	8.00	2-3V	215	1.54	4.50	6.90	4-3V	179	1.75	4.00	7.00	5-A
206	1.52	6.20	9.40	2-B	215	1.54	4.80	7.40	3-B	186	1.68	4.12	6.90	4-3V
215	1.45	4.50	6.50	3- 3V	226	1.46	4.12	6.00	4-3V	186	1.68	7.40	12.40	2-B
215	1.45	6.20	9.00	2-A	226	1.46	5.60	8.20	3-A	195	1.61	5.00	8.00	3-3V
225	1.38	5.00	6.90	2-3V	239	1.38	5.00	6.90	3-3V	195	1.60	4.00	6.40	5-A
225	1.39	6.20	8.60	2-B	239	1.39	6.20	8.60	3-B	203	1.54	6.90	10.60	3-3V
236	1.32	10.60	14.00	2-3V	248	1.34	4.50	6.00	4-3V	203	1.54	4.80	7.40	4-B
236	1.32	5.00	6.60	3-B	248	1.33	4.80	6.40	3-B	206	1.51	5.30	8.00	4-3V
246	1.27	4.75	6.00	3-3V	254	1.30	5.00	6.50	3-3V	206	1.52	6.20	9.40	3-B
246	1.26	6.80	8.60	2-B	254	1.30	4.60	6.00	4-A	213	1.47	6.40	9.40	3-B
254	1.23	5.30	6.50	3-3V	265	1.25	4.50	5.60	4-3V	214	1.46	7.10	10.30	3-5V
254	1.23	4.40	5.40	4-A	265	1.25	4.80	6.00	3-B	218	1.43	5.60	8.00	4-3V
264	1.18	4.50	5.30	3-3V	280	1.18	4.75	5.60	4-3V	218	1.43	6.00	8.60	3-B
264	1.18	5.60	6.60	3-B	280	1.18	4.40	5.20	4-A	230	1.36	14.00	19.00	2-3V
275	1.13	5.30	6.00	3-3V	285	1.16	5.60	6.50	3-3V	230	1.36	7.00	9.50	3-C
275	1.13	6.00	6.80	3-B	285	1.16	7.40	8.60	2-B	236	1.32	10.60	14.00	3-3V
285	1.09	4.12	4.50	4-3V	295	1.12	5.00	5.60	3-3V	236	1.32	5.60	7.40	4-B
285	1.09	8.60	9.40	2-B	295	1.12	6.60	7.40	3-B	246	1.27	7.10	9.00	3-5V
296	1.05	4.75	5.00	3-3V	312	1.06	5.00	5.30	3-3V	246	1.27	7.40	9.40	3-B
296	1.05	3.80	4.00	4-A	312	1.06	6.40	6.80	3-B	253	1.23	6.00	7.40	3-B
312	1.00	4.50	4.50	3-3V	331	1.00	4.12	4.12	4-3V	254	1.23	6.50	8.00	3-3V
312	1.00	6.20	6.20	2-B	331	1.00	8.60	8.60	2-B	260	1.20	7.10	8.50	3-5V
327	0.95	4.20	4.00	4-A	349	0.95	5.00	4.75	4-3V	260	1.20	7.50	9.00	3-C
328	0.95	5.00	4.75	3-3V	349	0.95	3.80	3.60	5-A	269	1.16	6.90	8.00	3-3V
334	0.91	6.00	5.60	3-3V	355	0.93	6.00	5.60	3-3V	269	1.16	7.40	8.60	3-B
334	0.93	6.00	5.60	3-A	355	0.93	6.00	5.60	3-A	277	1.13	7.10	8.00	3-5V
341	0.91	4.50	4.12	3-3V	362	0.91	4.50	4.12	4-3V	277	1.13	11.00	12.40	2-B
341	0.91	9.40	8.60	2-B	362	0.91	9.40	8.60	2-B	294	1.06	8.00	8.50	3-C
349	0.89	5.60	5.00	3-3V	374	0.88	4.12	3.65	5-3V	296	1.06	7.10	7.50	3-5V
349	0.89	7.40	6.60	2-B	374	0.88	5.20	4.60	3-B	330	0.95	7.50	7.10	3-5V
360	0.87	4.75	4.12	3-3V	375	0.88	6.00	5.30	3-3V	332	0.94	8.50	8.00	3-C
360	0.86	7.40	6.40	2-B	375	0.88	6.80	6.00	3-B	342	0.91	9.40	8.60	3-B
368	0.85	5.30	4.50	3-3V	384	0.86	8.00	6.90	3-3V	343	0.91	9.00	8.20	3-A
368	0.85	5.20	4.40	3-A	384	0.86	5.80	5.00	3-B	363	0.86	8.60	7.40	3-B
384	0.81	8.00	6.50	2-3V	391	0.85	5.60	4.75	3-3V	366	0.85	11.00	9.40	3-B
384	0.81	7.40	6.00	2-B	391	0.85	5.20	4.40	4-A	368	0.85	10.60	9.00	3-A
394	0.79	8.60	6.80	2-B	397	0.83	4.80	4.00	4-A	375	0.83	9.00	7.50	3-C
395	0.79	6.00	4.75	3-3V	398	0.83	6.00	5.00	3-3V	397	0.79	9.40	7.40	3-B

Note: These V-belts drives are designed for average service and are based on reducer ratings. Where fire hazards are prevalent and fire prevention laws apply, it is recommended that drives be redesigned using a service factor of 2.0 on the hp rating of the motor - refer to V-belt drive tables or consult DODGE

* DODGE stock sheaves. outside diameters shown for DYNA-V (3V); pitch diameters for A & B sheaves. All ratios based on P.D. Sheaves in shaded area represent speed up drives

FEATURES/BENEFITS PAGE G2-3	NOMENCLATURE PAGE G2-11	SELECTION/DIMENSIONS PAGE G2-144	RELATED PRODUCTS PAGE G2-152
--------------------------------	----------------------------	-------------------------------------	---------------------------------

RELATED PRODUCTS



TORQUE-ARM Shaft Mount Speed Reducers

V-BELT DRIVES FOR TXT405A, SCXT405A; TXT505A, SCXT505A; TXT605, SCXT605 REDUCERS - 3VX, 5VX, 8VX, AX, BX, CX AND DX BELTS REQUIRED

These are typical drives for average service conditions. For other conditions, output speeds or motor speeds see reducer specification for minimum driven sheave diameter and use V-belt selection tables.

Size 405A Driven by 1750 RPM Motor					Size 505A Driven by 1750 RPM Motor					Size 605 Driven by 1750 RPM Motor				
Output RPM	V-belt Drive Ratio	Sheave Diameters *		Qty & Belt Size	Output RPM	V-belt Drive Ratio	Sheave Diameters *		Qty & Belt Size	Output RPM	V-belt Drive Ratio	Sheave Diameters *		Qty & Belt Size
100	3.33	5.40	18.00	5-A	100	3.08	5.00	15.40	5-B	101	3.05	9.25	28.00	3-5V
100	3.33	6.00	20.00	4-B	102	3.01	7.10	21.20	3-5V	101	3.07	6.00	18.40	6-B
110	3.01	7.10	21.20	3-5V	102	3.03	6.60	20.00	4-B	108	2.85	7.50	21.20	3-5V
110	3.03	6.60	20.00	3-B	110	2.82	5.00	14.00	5-3V	108	2.85	5.40	15.40	6-B
120	2.77	6.90	19.00	3-3V	110	2.81	6.40	18.00	5-A	116	2.66	5.10	14.00	8-3V
120	2.78	5.40	15.00	5-A	116	2.66	5.30	14.00	6-3V	116	2.66	9.40	25.00	4-B
129	2.57	7.00	18.00	4-A	116	2.66	5.80	15.40	5-B	131	2.36	10.60	25.00	4-3V
129	2.58	4.80	12.40	4-B	130	2.38	8.00	19.00	4-3V	131	2.35	8.50	20.00	4-C
138	2.41	6.40	15.40	3-B	130	2.38	5.20	12.40	6-B	136	2.27	7.10	16.00	4-5V
138	2.40	7.50	18.00	3-C	136	2.27	7.10	16.00	3-5V	136	2.26	6.80	15.40	6-B
146	2.27	7.10	16.00	3-5V	136	2.26	6.80	15.40	4-B	141	2.19	9.75	21.20	3-5V
146	2.27	11.00	25.00	3-B	144	2.15	7.50	16.00	3-5V	141	2.20	8.20	18.00	6-B
155	2.15	7.50	16.00	3-5V	144	2.14	5.80	12.40	5-B	149	2.07	10.30	21.20	3-5V
155	2.14	5.60	12.00	6-A	152	2.04	6.90	14.00	5-3V	149	2.07	6.00	12.40	6-B
163	2.04	5.20	10.60	6-A	152	2.04	5.40	11.00	6-B	158	1.95	10.90	21.20	3-5V
163	2.04	5.40	11.00	5-B	158	1.95	10.90	21.20	3-5V	158	1.96	9.40	18.40	5-B
170	1.96	4.60	9.00	6-A	158	1.96	9.40	18.40	4-B	165	1.87	7.10	13.20	4-5V
170	1.96	4.80	9.40	5-B	165	1.87	7.10	13.20	4-5V	165	1.87	7.50	14.00	5-C
178	1.87	7.10	13.20	3-5V	165	1.88	6.40	12.00	6-A	172	1.80	10.60	19.00	4-3V
178	1.87	7.50	14.00	3-C	172	1.80	10.60	19.00	4-3V	172	1.79	8.60	15.40	5-B
185	1.80	5.00	9.00	6-A	172	1.79	8.60	15.40	4-B	178	1.74	9.25	16.00	3-5V
185	1.79	4.80	8.60	5-B	178	1.74	9.25	16.00	3-5V	178	1.73	7.50	13.00	4-C
192	1.73	5.20	9.00	6-A	178	1.73	7.50	13.00	4-C	184	1.68	7.50	12.50	5-5V
192	1.73	7.50	13.00	3-C	184	1.68	7.50	12.50	3-5V	184	1.68	7.40	12.40	6-B

Note: These V-belts drives are designed for average service and are based on reducer ratings. Where fire hazards are prevalent and fire prevention laws apply, it is recommended that drives be redesigned using a service factor of 2.0 on the hp rating of the motor - refer to V-belt drive tables or consult DODGE

* DODGE stock sheaves, outside diameters shown for DYNA-V (3V); pitch diameters for A & B sheaves. All ratios based on P.D. Sheaves in shaded area represent speed up drives



TORQUE-ARM Shaft Mount Speed Reducers

V-BELT DRIVES FOR TXT405A, SCXT405A; TXT505A, SCXT505A; TXT605, SCXT605 REDUCERS - 3VX, 5VX, 8VX, AX, BX, CX AND DX BELTS REQUIRED

These are typical drives for average service conditions. For other conditions, output speeds or motor speeds see reducer specification for minimum driven sheave diameter and use V-belt selection tables.

Size 405A Driven by 1750 RPM Motor					Size 505A Driven by 1750 RPM Motor					Size 605 Driven by 1750 RPM Motor				
Output RPM	V-belt Drive Ratio	Sheave Diameters *		Qty & Belt Size	Output RPM	V-belt Drive Ratio	Sheave Diameters *		Qty & Belt Size	Output RPM	V-belt Drive Ratio	Sheave Diameters *		Qty & Belt Size
201	1.65	8.50	14.00	3-5V	184	1.68	7.40	12.40	5-B	190	1.63	9.25	15.00	4-5V
201	1.66	6.40	10.60	4-A	190	1.63	9.25	15.00	3-5V	190	1.63	8.00	13.00	5-C
208	1.60	7.50	12.00	3-C	190	1.63	8.00	13.00	3-C	197	1.57	8.00	12.50	4-5V
208	1.60	10.00	16.00	3-C	201	1.54	6.90	10.60	5-3V	197	1.57	7.00	11.00	6-C
216	1.54	6.90	10.60	4-3V	201	1.54	13.00	20.00	3-C	203	1.52	9.25	14.00	4-5V
216	1.54	5.60	8.60	5-B	210	1.47	9.00	13.20	3-5V	203	1.52	10.50	16.00	4-C
224	1.48	8.00	11.80	3-5V	210	1.47	6.40	9.40	5-B	210	1.47	10.90	14.00	3-5V
224	1.48	5.80	8.60	5-B	216	1.43	9.25	13.20	3-5V	210	1.47	9.50	16.00	4-C
232	1.43	5.60	8.00	5-3V	216	1.43	7.00	10.00	4-C	216	1.43	9.25	13.20	4-5V
232	1.43	9.25	13.20	3-5V	226	1.37	8.00	10.90	3-5V	216	1.43	7.00	10.00	6-C
240	1.39	6.20	8.60	5-B	226	1.37	9.50	13.00	3-C	226	1.37	8.00	10.90	4-5V
240	1.38	6.80	9.40	4-B	234	1.32	10.60	14.00	4-3V	226	1.37	9.50	13.00	4-C
249	1.34	6.00	8.00	5-3V	234	1.32	9.40	12.40	4-B	234	1.32	10.60	14.00	5-3V
249	1.33	9.00	12.00	5-A	240	1.29	8.50	10.90	3-5V	234	1.32	9.40	12.40	5-B
258	1.29	8.50	10.90	3-5V	240	1.29	7.00	9.00	6-A	240	1.28	10.30	13.20	3-5V
258	1.29	7.00	9.00	5-A	250	1.24	7.50	9.25	3-5V	240	1.29	7.00	9.00	6-C
266	1.25	12.00	15.00	4-A	250	1.24	8.50	10.50	3-C	250	1.24	7.50	9.25	5-5V
266	1.25	8.00	10.00	3-C	262	1.18	9.25	10.90	3-5V	250	1.24	8.50	10.50	5-C
272	1.22	8.00	9.75	3-5V	262	1.18	9.00	10.60	6-A	260	1.19	11.80	14.00	3-5V
272	1.22	9.00	11.00	3-C	270	1.14	14.00	16.00	3-5V	260	1.19	8.00	9.50	5-C
282	1.18	9.25	10.90	3-5V	270	1.14	10.50	12.00	3-C	270	1.14	14.00	16.00	3-5V
282	1.18	9.00	10.60	5-A	277	1.11	9.25	10.30	3-5V	270	1.14	7.00	8.00	6-C
290	1.15	9.00	10.30	3-5V	278	1.11	9.00	10.00	4-C	276	1.12	11.80	13.20	3-5V
290	1.15	10.30	11.80	3-5V	285	1.08	9.00	9.75	3-5V	276	1.12	8.50	9.50	5-C
297	1.12	9.75	10.90	3-5V	285	1.08	12.00	13.00	3-C	285	1.08	10.90	11.80	3-5V
297	1.12	8.50	9.50	3-C	293	1.05	9.25	9.75	3-5V	285	1.08	12.00	13.00	4-C
304	1.09	6.40	7.00	6-A	293	1.06	9.00	9.50	4-C	292	1.06	12.50	13.20	3-5V
304	1.09	8.60	9.40	4-B	309	1.00	10.60	10.60	4-3V	292	1.06	8.50	9.00	5-C
312	1.06	8.00	8.50	3-5V	309	1.00	11.00	11.00	4-B	309	1.00	11.80	11.80	3-5V
312	1.07	7.50	8.00	4-C	335	0.92	9.75	9.00	3-5V	309	1.00	11.00	11.00	5-B
316	1.05	9.50	10.00	3-C	335	0.92	13.00	12.00	3-C	326	0.95	13.20	12.50	3-5V
316	1.05	10.00	10.50	3-C	341	0.90	10.50	9.50	4-C	326	0.95	9.50	9.00	5-C
332	1.00	10.90	10.90	3-5V	344	0.90	10.30	9.25	3-5V	335	0.92	9.75	9.00	4-5V
332	1.00	7.00	7.00	6-A	353	0.88	12.00	10.50	3-C	335	0.92	13.00	12.00	4-C
350	0.95	9.75	9.25	3-5V	354	0.87	10.30	9.00	3-5V	348	0.89	9.00	8.00	5-5V
350	0.95	10.00	9.50	3-C	365	0.85	10.90	9.25	3-5V	348	0.89	12.40	11.00	5-B
360	0.92	9.75	9.00	3-5V	365	0.85	13.00	11.00	3-C	358	0.86	8.00	6.90	8-3V
360	0.92	11.80	10.90	3-5V	375	0.82	10.90	9.00	3-5V	358	0.86	11.00	9.50	5-C
375	0.89	8.00	7.10	3-5V	382	0.81	13.00	10.50	3-C	377	0.82	9.75	8.00	4-5V
375	0.89	12.40	11.00	3-B	395	0.78	11.80	9.25	3-5V	377	0.82	11.00	9.00	5-C
399	0.83	8.50	7.10	3-5V	397	0.78	12.50	9.75	3-5V	399	0.77	10.30	8.00	4-5V

Note: These V-belts drives are designed for average service and are based on reducer ratings. Where fire hazards are prevalent and fire prevention laws apply, it is recommended that drives be redesigned using a service factor of 2.0 on the hp rating of the motor - refer to V-belt drive tables or consult DODGE

* DODGE stock sheaves. outside diameters shown for DYNA-V (3V); pitch diameters for A & B sheaves. All ratios based on P.D. Sheaves in shaded area represent speed up drives

FEATURES/BENEFITS PAGE G2-3	NOMENCLATURE PAGE G2-11	SELECTION/DIMENSIONS PAGE G2-144	RELATED PRODUCTS PAGE G2-152
--------------------------------	----------------------------	-------------------------------------	---------------------------------

RELATED PRODUCTS



TORQUE-ARM Shaft Mount Speed Reducers

V-BELT DRIVES FOR TXT605, SCXT605; TXT705, SCXT705; TXT805, TXT905 REDUCERS 3VX, 5VX, 8VX, AX, BX, CX AND DX BELTS REQUIRED

These are typical drives for average service conditions. For other conditions, output speeds or motor speeds see reducer specification for minimum driven sheave diameter and use V-belt selection tables.

TXT705 Driven by 1750 RPM Motor					TXT805 Driven by 1750 RPM Motor					TXT905 Driven by 1750 RPM Motor				
Output RPM	V-belt Drive Ratio	Sheave Diameters *		Qty & Belt Size	Output RPM	V-belt Drive Ratio	Sheave Diameters *		Qty & Belt Size	Output RPM	V-belt Drive Ratio	Sheave Diameters *		Qty & Belt Size
100	3.27	11.00	36.00	4-C	100	3.17	10.60	33.50	8-3V	102	3.20	11.80	37.50	5-5V
103	3.17	10.60	33.50	5-3V	100	3.19	9.40	30.00	10-B	103	3.17	10.60	33.50	10-3V
103	3.16	9.50	30.00	4-V	104	3.05	9.25	28.00	5-5V	103	3.14	14.00	44.00	5-C
115	2.85	7.50	21.20	4-5V	104	3.06	12.40	38.00	6-B	104	3.13	9.00	28.00	6-5V
116	2.82	8.50	24.00	5-C	111	2.85	13.20	37.50	4-5V	108	3.02	12.50	37.50	5-5V
122	2.67	8.00	21.20	5-5V	111	2.86	10.50	30.00	5-C	108	3.00	12.00	36.00	8-C
123	2.66	9.40	25.00	6-B	116	2.74	10.30	28.00	4-5V	114	2.85	13.20	37.50	5-5V
130	2.51	8.50	21.20	4-5V	117	2.73	11.00	30.00	8-B	117	2.77	13.00	36.00	6-C
131	2.50	12.00	30.00	4-C	123	2.58	10.90	28.00	4-5V	121	2.69	14.00	37.50	5-5V
142	2.31	9.25	21.20	4-5V	124	2.57	14.00	36.00	4-C	126	2.58	10.90	28.00	6-5V
142	2.31	13.00	30.00	4-C	133	2.38	11.80	28.00	4-5V	126	2.57	14.00	36.00	6-C
145	2.25	12.50	28.00	3-5V	133	2.40	10.00	24.00	5-C	130	2.50	12.00	30.00	8-C
145	2.25	8.00	18.00	6-C	138	2.31	9.25	21.20	6-5V	134	2.42	12.40	30.00	10-B
153	2.13	13.20	28.00	3-5V	138	2.31	13.00	30.00	5-C	136	2.38	11.80	28.00	5-5V
153	2.14	8.60	18.40	8-B	141	2.25	12.50	28.00	4-5V	141	2.31	13.00	30.00	6-C
162	2.01	7.50	15.00	5-5V	141	2.25	12.00	27.00	5-D	144	2.25	12.50	28.00	5-5V
162	2.02	12.40	25.00	5-B	148	2.14	14.00	30.00	5-C	144	2.25	12.00	27.00	6-D
174	1.88	7.50	14.00	5-5V	149	2.13	13.20	28.00	4-5V	153	2.13	13.20	28.00	6-5V
174	1.88	8.50	16.00	5-C	159	2.01	14.00	28.00	4-5V	162	2.01	14.00	28.00	5-5V
181	1.80	11.80	21.20	3-5V	159	2.00	12.00	24.00	6-C	166	1.95	10.90	21.20	8-5V
181	1.80	10.00	18.00	4-C	167	1.90	10.50	20.00	6-C	180	1.80	11.80	21.20	6-5V
195	1.67	9.00	15.00	5-5V	172	1.85	13.00	24.00	5-C	182	1.79	14.00	25.00	10-3V
195	1.67	11.00	18.40	6-B	177	1.80	10.60	19.00	8-3V	191	1.70	12.50	21.20	6-5V

Note: These V-belts drives are designed for average service and are based on reducer ratings. Where fire hazards are prevalent and fire prevention laws apply, it is recommended that drives be redesigned using a service factor of 2.0 on the hp rating of the motor - refer to V-belt drive tables or consult DODGE

* DODGE stock sheaves. outside diameters shown for DYNA-V (3V); pitch diameters for A & B sheaves. All ratios based on P.D. Sheaves in shaded area represent speed up drives

RELATED PRODUCTS



TORQUE-ARM Shaft Mount Speed Reducers

V-BELT DRIVES FOR TXT605, SCXT605; TXT705, SCXT705; TXT805, TXT905 REDUCERS 3VX, 5VX, 8VX, AX, BX, CX AND DX BELTS REQUIRED

These are typical drives for average service conditions. For other conditions, output speeds or motor speeds see reducer specification for minimum driven sheave diameter and use V-belt selection tables.

TXT705 Driven by 1750 RPM Motor					TXT805 Driven by 1750 RPM Motor					TXT905 Driven by 1750 RPM Motor				
Output RPM	V-belt Drive Ratio	Sheave Diameters *		Qty & Belt Size	Output RPM	V-belt Drive Ratio	Sheave Diameters *		Qty & Belt Size	Output RPM	V-belt Drive Ratio	Sheave Diameters *		Qty & Belt Size
203	1.61	13.20	21.20	4-5V	178	1.79	9.00	16.00	6-5V	202	1.61	13.20	21.20	6-5V
203	1.61	12.40	20.00	6-B	183	1.74	9.25	16.00	6-5V	213	1.53	12.50	19.00	5-8V
212	1.54	9.75	15.00	5-5V	186	1.71	10.50	18.00	6-C	214	1.52	14.00	21.20	5-5V
212	1.54	13.00	20.00	4-C	190	1.67	9.00	15.00	6-5V	221	1.47	10.90	16.00	8-5V
222	1.47	10.90	16.00	4-5V	190	1.67	11.00	18.40	6-C	225	1.45	12.50	18.00	5-8V
222	1.47	9.50	14.00	5-C	197	1.61	12.40	20.00	8-B	236	1.38	10.90	15.00	8-5V
234	1.39	9.00	12.50	5-5V	198	1.61	13.20	21.20	5-5V	238	1.37	12.50	17.00	5-8V
236	1.38	13.00	18.00	4-C	207	1.54	13.00	20.00	6-C	239	1.36	11.80	16.00	6-5V
248	1.31	9.00	11.80	5-5V	210	1.52	14.00	21.20	5-5V	253	1.28	12.50	16.00	6-5V
248	1.32	9.40	12.40	8-B	214	1.48	12.40	18.40	8-B	255	1.27	11.80	15.00	6-5V
257	1.27	11.80	15.00	4-5V	216	1.47	10.90	16.00	6-5V	268	1.21	10.90	13.20	8-5V
257	1.27	11.00	14.00	5-C	230	1.38	13.00	18.00	6-C	270	1.20	12.50	15.00	6-5V
263	1.24	12.40	15.40	6-B	231	1.38	10.90	15.00	6-5V	274	1.19	11.80	14.00	6-5V
264	1.24	10.50	13.00	5-C	234	1.36	11.80	16.00	5-5V	284	1.14	14.00	16.00	6-5V
272	1.20	12.50	15.00	4-5V	239	1.33	12.00	16.00	6-C	285	1.14	13.20	15.00	5-8V
272	1.20	10.00	12.00	5-C	247	1.29	10.90	14.00	6-5V	286	1.14	13.20	15.00	8-5V
286	1.14	14.00	16.00	3-5V	247	1.29	14.00	18.00	6-C	303	1.07	14.00	15.00	8-5V
286	1.14	10.50	12.00	5-C	256	1.24	12.40	15.40	8-B	306	1.06	13.20	14.00	8-5V
293	1.11	9.25	10.30	5-5V	259	1.23	13.00	16.00	6-C	325	1.00	13.20	13.20	8-5V
296	1.11	9.50	10.50	5-C	263	1.21	12.00	14.50	6-D	343	0.95	13.20	12.50	8-5V
302	1.08	10.90	11.80	4-5V	265	1.20	12.50	15.00	5-5V	345	0.94	14.00	13.20	8-5V
302	1.08	12.00	13.00	5-C	268	1.19	11.80	14.00	5-5V	364	0.89	14.00	12.50	8-5V
310	1.05	9.25	9.75	5-5V	268	1.19	13.50	16.00	5-D	365	0.89	14.00	12.50	6-8V
310	1.05	9.50	10.00	6-C	277	1.15	10.90	12.50	6-5V	386	0.84	14.00	11.80	8-5V
327	1.00	10.30	10.30	4-5V	277	1.15	13.50	15.50	5-D	394	0.82	13.20	10.90	10-5V
327	1.00	11.00	11.00	6-B	283	1.13	12.00	13.50	6-D					
336	0.97	9.25	9.00	5-5V	284	1.12	11.80	13.20	5-5V					
342	0.95	11.00	10.50	5-C	294	1.08	10.90	11.80	5-5V					
345	0.95	9.75	9.25	5-5V	294	1.08	12.00	13.00	8-C					
345	0.95	9.50	9.00	6-C	297	1.07	14.00	15.00	5-5V					
354	0.92	11.80	10.90	4-5V	297	1.07	14.00	15.00	5-D					
354	0.92	13.00	12.00	4-C	306	1.04	13.00	13.50	6-D					
364	0.90	10.30	9.25	5-5V	307	1.04	13.50	14.00	5-D					
365	0.89	9.50	8.50	6-C	318	1.00	12.50	12.50	5-5V					
378	0.86	9.25	8.00	5-5V	318	1.00	13.00	13.00	6-C					
378	0.86	11.00	9.50	5-C	336	0.95	13.20	12.50	6-5V					
386	0.85	10.90	9.25	5-5V	337	0.94	10.90	10.30	8-5V					
386	0.85	13.00	11.00	5-C	356	0.89	10.90	9.75	8-5V					
392	0.83	12.00	10.00	5-C	357	0.89	14.00	12.50	6-5V					
393	0.83	9.00	7.50	6-5V	376	0.85	10.90	9.25	10-5V					
399	0.82	9.75	8.00	5-5V	378	0.84	14.00	11.80	6-5V					
399	0.82	11.00	9.00	5-C	387	0.82	12.50	10.30	8-5V					

Note: These V-belts drives are designed for average service and are based on reducer ratings. Where fire hazards are prevalent and fire prevention laws apply, it is recommended that drives be redesigned using a service factor of 2.0 on the hp rating of the motor - refer to V-belt drive tables or consult DODGE

* DODGE stock sheaves. outside diameters shown for DYNA-V (3V); pitch diameters for A & B sheaves. All ratios based on P.D. Sheaves in shaded area represent speed up drives

FEATURES/BENEFITS PAGE G2-3	NOMENCLATURE PAGE G2-11	SELECTION/DIMENSIONS PAGE G2-144	RELATED PRODUCTS PAGE G2-152
--------------------------------	----------------------------	-------------------------------------	---------------------------------

RELATED PRODUCTS



TORQUE-ARM Shaft Mount Speed Reducers DODGE TORQUE-ARM PROTECTION PLAN

Pre-Packaged Rebuild Kits For TXT & SCXT Reducers

The DODGE TORQUE-ARM Reducer is America's #1 Shaft Mount Reducer. TORQUE-ARM reducers are designed to achieve optimum service life from all components. Wear will occur over the service life of the reducer, particularly bearings and seals. To rebuild TORQUE-ARM Reducers to factory tolerances and specifications, use genuine DODGE replacement parts.

SAVE TIME AND MONEY

The new TORQUE-ARM Level I and Level II Rebuild Kits minimize the cost of downtime and maximize productivity by having the parts available before they are needed. A

formal preventative maintenance program should include the scheduling of a rebuild before a problem occurs.

Machine downtime usually means lost profits and reduced productivity. Every minute your line is down, production output is reduced, schedules are delayed and return on investment is threatened; consider:

- Time and cost to diagnose failure
- Time and cost to order replacement parts
- Time and cost waiting for parts to arrive
- Time and cost to repair
- Total downtime costs

FEATURES/BENEFITS PAGE G2-3	NOMENCLATURE PAGE G2-11	SELECTION/DIMENSIONS PAGE G2-144	RELATED PRODUCTS PAGE G2-152
--------------------------------	----------------------------	-------------------------------------	---------------------------------

RELATED PRODUCTS



TORQUE-ARM Shaft Mount Speed Reducers DODGE TORQUE-ARM PROTECTION PLAN

EASY AND SIMPLE TO ORDER

Selecting the correct Reducer Kit is easy. A DODGE part number has been pre-assigned for each kit. This means fewer parts to select, fewer line items to order and less chance of downtime because of missing parts. Each kit includes complete rebuild instructions and all necessary hardware for making the repair. Shims, gaskets and even gearcase sealant are included. Each part number in the kit is clearly labeled with description and part number. No time is wasted looking for parts. All parts for Rebuild Kits are overpacked and shipped in one box.

Level I Rebuild Kit

- Spring-loaded lip input seal
- Complete set of spring-loaded lip output seal
- Complete set of input, counter-shaft and output bearings
- Shim kit ● Gearcase sealant ● Instruction Manual

Level II Rebuild Kit

- First stage high speed input shaft and pinion
- First stage mating reduction gear
- Spring-loaded lip input seals
- Complete set of spring-loaded lip output seals
- Complete set of input, counter-shaft and output bearings
- Shim kit ● Gearcase sealant ● Instruction Manual

LEVEL I KIT

Part #	Size
392270	TXT109, 115, 125
392274	TXT209, 215, 225
392278	TXT & SCXT309A, 315A, 325A
392282	TXT & SCXT409A, 415A, 425A
392286	TXT & SCXT509B, 515B
392287	TXT & SCXT525B
392291	TXT & SCXT609, 615, 625
392295	TXT & SCXT709, 715, 725
392299	TXT815, 825
392302	TXT915, 926
392305	TXT1015, 1024
392308	TXT1215, 1225
392311	TDT1325
392313	TDT1425
392315	TDT1530

LEVEL II KIT

Part #	Size
392271	TXT109
392272	TXT115
392273	TXT125
392275	TXT209
392276	TXT215
392277	TXT225
392279	TXT & SCXT309A
392280	TXT & SCXT315A
392281	TXT & SCXT325A
392283	TXT & SCXT409A
392284	TXT & SCXT415A
392285	TXT & SCXT425A
392288	TXT & SCXT509B
392289	TXT & SCXT515B
392290	TXT & SCXT525B
392292	TXT & SCXT609
392293	TXT & SCXT615
392294	TXT & SCXT625
392296	TXT & SCXT709
392297	TXT & SCXT715
392298	TXT & SCXT725
392300	TXT815
392301	TXT825
392303	TXT915
392304	TXT926
392306	TXT1015
392307	TXT1024
392309	TXT1215
392310	TXT1225
392312	TDT1325
392314	TDT1425
392316	TDT1530

FEATURES/BENEFITS PAGE G2-3	NOMENCLATURE PAGE G2-11	SELECTION/DIMENSIONS PAGE G2-144	RELATED PRODUCTS PAGE G2-152
--------------------------------	----------------------------	-------------------------------------	---------------------------------

RENEWAL PARTS



TORQUE-ARM Shaft Mount Speed Reducers

RENEWAL PARTS FOR TORQUE-ARM REDUCERS

TORQUE-ARM REDUCER SEAL KITS ●	
PART NUMBER	SIZE
241340	TD-TDT1 Seal Kit
242340	TD-TDT2 Seal Kit
243340	TD-TDT-TXT3 Seal Kit
244340	TD-TDT4 Seal Kit
245340	TD-TDT-TXT5 Seal Kit
246340	TDT-TXT-C6-SCXT6 Seal Kit
247345	TDT7-TXT7-C7-SCXT7-T17-C17-TXT705 SCXT705 Seal Kit
248340	TDT-TXT8-T18-TXT805 Seal Kit
249340	TD-TDT-TXT9 Seal Kit
272460	TD-TDT-TXT10 Seal Kit
272700	#11 -T11 -TXT105 Seal Kit
272701	#12-T12-TXT205 Seal Kit
272702	#13-T13-TXT305 Seal Kit
272703	#14-T14-TXT405 Seal Kit
272704	#15-T15-TXT505 Seal Kit
272705	T16-C16-TXT605-SCXT605 Seal Kit
272708	T19-TXT905 Seal Kit
272710	C1 Seal Kit
272711	SCXT1 Seal Kit
272712	SCXT2-C2 Seal Kit
272713	SCXT3-C3 Seal Kit
272714	SCXT4-C4 Seal Kit
272715	SCXT5-C5 Seal Kit
272716	SCXT105-C11 Seal Kit
272717	SCXT205-C12 Seal Kit
272718	SCXT305-C13 Seal Kit
272719	SCXT405-C14 Seal Kit
272720	SCXT505-C15 Seal Kit
389720	TXT, SCXT, HXT309A-325A Seal Kit
389721	TXT, SCXT, HXT409A-425A Seal Kit
389722	TXT, SCXT, HXT509B-525B Seal Kit
389726	TXT, SCXT, HXT305A Seal Kit
389727	TXT, SCXT, HXT405A Seal Kit
389728	TXT, SCXT, HXT505A Seal Kit
392119	TXT1 Seal Kit
392120	TXT2 Seal Kit
392121	TXT4 Seal Kit

- # Series, T-series and 5:1 reducers are single reduction gear boxes

Parts for HYDROIL Vane Motors

HYDROIL Motor Size	Part Number		
	Motor Shaft	Seal Kit *	Motor Shaft Seal
A10	391658	391657	391659
A20	391658	391657	391659
B30	444059	444058
B40	444062	444061
B50

* Seal kit includes motor shaft seal.

TORQUE-ARM REDUCER BEARING KITS ●	
PART NUMBER	SIZE
389900	IDT1 BEARING KIT
389901	TDT2 HT2 BEARING KIT
389902	TDT3 HT3 BEARING KIT
389903	TDT4 HT4 BEARING KIT
389904	TDT5 HT5 BEARING KIT
389905	TXT1 - HXT1 BEARING KIT
389906	TXT2 - HXT2 BEARING KIT
389907	TXT3 - HXT3 BEARING KIT
389908	TXT4 - HXT4 BEARING KIT
389909	TXT5 - HXT5 BEARING KIT
389910	TXT105 - T11 BEARING KIT
389911	TXT205 - HXT205 BEARING KIT
389912	TXT305 - HXT305 - T13 - HT13 BEARING KIT
389913	TXT405 - HXT405 BEARING KIT
389914	TXT505 - HXT505 - T15 - HT15 BEARING KIT
389915	T14 - HT14 BEARING KIT
389916	HXT105 - HT11 BEARING KIT
389587	TXT3A INPUT BEARING KIT
389588	TXT3A COUNTERSHAFT BEARING KIT
389589	TXT3A OUTPUT BEARING KIT
389590	TXT4A INPUT BEARING KIT
389591	TXT4A COUNTERSHAFT BEARING KIT
389592	TXT4A OUTPUT BEARING KIT
389593	TXT509B - 515B INPUT BEARING KIT
389594	TXT525B INPUT BEARING KIT
389595	TXT5B COUNTERSHAFT BEARING KIT
389596	TXT5B OUTPUT BEARING KIT
389597	TXT305A INPUT BEARING KIT
389598	TXT405A INPUT BEARING KIT
389599	TXT505A INPUT BEARING KIT

- T-series and 5:1 reducers are single reduction gear boxes

Drive Shafts for OLD STYLE (Prior to 1992) SCXT 3 - 4 - 5 Reducers

Part Number	Drive Shaft
353042	SCXT 3 x 1-1/2
353043	SCXT 3 x 2
353044	SCXT 3 x 2-7/16
353045	SCXT 3 x 3
354116	SCXT 4 x 1-1/2
354117	SCXT 4 x 2
354118	SCXT 4 x 2-7/16
354119	SCXT 4 x 3
354120	SCXT 4 x 3-7/16
355076	SCXT 5 x 2
355077	SCXT 5 x 2-7/16
355078	SCXT 5 x 3
355079	SCXT 5 x 3-7/16

FEATURES/BENEFITS PAGE G2-3	NOMENCLATURE PAGE G2-11	SELECTION/DIMENSIONS PAGE G2-144	RELATED PRODUCTS PAGE G2-152
--------------------------------	----------------------------	-------------------------------------	---------------------------------



TORQUE-ARM Shaft Mount Speed Reducers LUBRICATION OF TORQUE-ARM REDUCERS

CAUTION: Unit is shipped without oil. Add proper amount of rust and oxidation inhibited (R & O) gear oil before operating. Failure to observe these precautions could result in damage to, or destruction of, the equipment.

Lubrication is extremely important for satisfactory operation. The proper oil level as shown in Table 25, page G2-199, must be maintained at all times. Frequent inspections with the unit not running and allowing sufficient time for the oil to cool and the entrapped air to settle out of the oil should be made by removing the level plug to see that the level is being maintained. If low, add the proper type and viscosity of lubricant through one of the upper openings until it comes out of the oil level hole. Replace the oil level plug securely. Refer to Tables 23 and 24 for viscosity recommendations.

After an initial operation of about two weeks, the oil should be changed. If desired, this oil may be filtered and reused. Very often, small metal particles will show up in the oil due to the wearing process. After the initial break in period, the lubricant should be drained, magnetic drain plug cleaned, gear case flushed and refilled every 2500 hours of operation under average industrial conditions.

CAUTION: Too much oil will cause overheating and too little will result in gear failure. Check oil level regularly.

More frequent oil changes are recommended when operating continuously or at high temperatures or under

conditions of extreme dirt or dust. Use only recommended lubricants listed on next page, or equivalent. Special attention should be given to checking of lubricants when any of the following conditions exist:

1. High operating temperatures resulting from heavy intermittent loads causes the temperature of the gear case to rise rapidly and then cool.
2. Unusual ambient conditions, which may tend to cause condensation on the inside of the gearcase thereby contaminating the oil.
3. Operating temperatures that would cause oil to approach 200°F continually.
4. Subjection of reducer to unusual vapors or moist atmosphere.
5. Subjection of reducer to extremely dusty or dirty environment.

Under these extreme operating conditions, the oil should be changed every 1 to 3 months depending on severity of conditions.

Operating Temperatures

Heating is a natural characteristic of enclosed gearing, and a maximum gear case temperature approaching 200°F is not uncommon for some units operating in normal ambient temperatures (80°F). When operating at rated capacity, no damage will result from this temperature as this was taken into consideration in the design of the gear case and in the selection of the lubricants.

FEATURES/BENEFITS PAGE G2-3	NOMENCLATURE PAGE G2-11	SELECTION/DIMENSIONS PAGE G2-144	RELATED PRODUCTS PAGE G2-152
--------------------------------	----------------------------	-------------------------------------	---------------------------------



ENGINEERING/TECHNICAL

TORQUE-ARM Shaft Mount Speed Reducers

LUBRICATION OF TORQUE-ARM REDUCERS (CON'T)

**TABLE 23: LUBRICATION RECOMMENDATIONS - ISO GRADES
FOR AMBIENT TEMPERATURES OF 50°F THRU 125°F** ◇

Output RPM	TXT, SCXT, HXT Reducers														
	1	2	3	4	5	6	7	8	9	10	12	13	14	15	
301-400	320	320	220	220	220	220	220	220	220	220	220	220	220	220	
201-300	320	320	220	220	220	220	220	220	220	220	220	220	220	220	
151-200	320	320	220	220	220	220	220	220	220	220	220	220	220	220	
126-150	320	320	320	220	220	220	220	220	220	220	220	220	220	220	
101-125	320	320	320	320	220	220	220	220	220	220	220	220	220	220	
81-100	320	320	320	320	320	220	220	220	220	220	220	220	220	220	
41-80	320	320	320	320	320	220	220	220	220	220	220	220	220	220	
11-40	320	320	320	320	320	320	320	320	320	320	220	220	220	220	
1-10	320	320	320	320	320	320	320	320	320	320	320	320	320	320	

**TABLE 24: LUBRICATION RECOMMENDATIONS - ISO GRADES
FOR AMBIENT TEMPERATURES OF 15°F THRU 60°F** ◇

Output RPM	TXT, SCXT, HXT Reducers														
	1	2	3	4	5	6	7	8	9	10	12	13	14	15	
301-400	220	220	150	150	150	150	150	150	150	150	150	150	150	150	
201-300	220	220	150	150	150	150	150	150	150	150	150	150	150	150	
151-200	220	220	150	150	150	150	150	150	150	150	150	150	150	150	
126-150	220	220	220	150	150	150	150	150	150	150	150	150	150	150	
101-125	220	220	220	220	150	150	150	150	150	150	150	150	150	150	
81-100	220	220	220	220	220	150	150	150	150	150	150	150	150	150	
41-80	220	220	220	220	220	150	150	150	150	150	150	150	150	150	
11-40	220	220	220	220	220	220	220	220	220	220	150	150	150	150	
1-10	220	220	220	220	220	220	220	220	220	220	220	220	220	220	

LUBRICANT GRADE EQUIVALENTS

ISO	AGMA
150	4
220	5
320	6

NOTE: Mobil SHC 600 Series oil is recommended for high ambient temperatures.

◇ **NOTES:**

1. Assumes auxiliary cooling where recommended in the catalog.
2. Pour point of lubricant selected should be at least 10°F lower than expected minimum ambient starting temperature.
3. Extreme pressure (EP) lubricants are not recommended for average operating conditions.
4. Special lubricants may be required for food and drug industry applications where contact with the product being manufactured may occur. Consult a lubrication manufacturer's representative for his recommendations.
5. Do not use oils containing EP additives such as graphite or molybdenum disulfide in the reducer when backstop is used. These additives will destroy sprag action.
6. For reducers operating in ambient temperatures between -22°F (-30°C) and 20°F (-6.6°C) use a synthetic hydrocarbon lubricant, 100 ISO grade or AGMA 35 grade (for example - Mobil SHC627). Above 125°F (51.6°C), consult DODGE Gear Application Engineering (864) 297-4800 for lubrication recommendation.

FEATURES/BENEFITS PAGE G2-3	NOMENCLATURE PAGE G2-11	SELECTION/DIMENSIONS PAGE G2-144	RELATED PRODUCTS PAGE G2-152
--------------------------------	----------------------------	-------------------------------------	---------------------------------



TORQUE-ARM Shaft Mount Speed Reducers LUBRICATION OF TORQUE-ARM REDUCERS (CON'TD)

Horizontal Installations-Install the magnetic drain plug in the hole closest to the bottom of the reducer. Throw away the tape that covers the filler/ventilation plug in shipment and install plug in topmost hole. Of the remaining plugs on the sides of the reducer, the lowest one is the minimum oil level plug. Vertical Installations-Install the filler/ventilation plug in the hole provided in the top face of the reducer housing. Use the hole in the bottom face for the magnetic drain plug. Of the remaining holes on the sides of the reducer, use a plug in the upper housing half for the minimum oil level plug.

The running position of the reducer in a horizontal application is not limited to the four positions shown below. However, if running position is over 20° either way from sketches, the oil level plug cannot be safely used to check the oil level, unless during the checking the torque arm is disconnected and the reducer is swung to within 20° in position B or D, or 5° in position A and C shown below. Because of the many possible positions of the reducer, it may be necessary or desirable to make special adaptations using the lubrication fitting holes furnished along with other standard pipe fittings, stand pipes and oil level gauges as required.

Mounting Positions

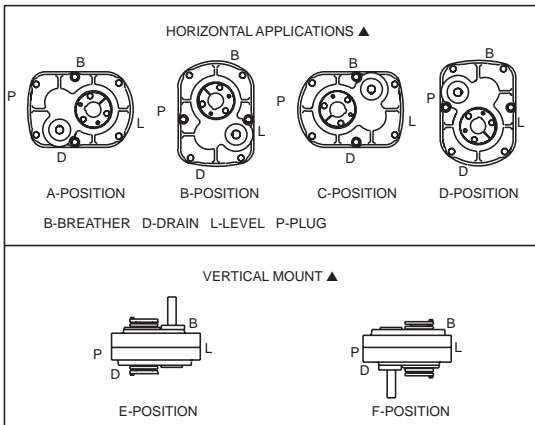

▲ Note: Below 15 RPM output speed, oil level must be adjusted to reach the highest oil level plug (P)

Vertical Installations - Install the filler/ventilation plug in the hole provided in the top face of the reducer housing. Use the hole in the bottom face for the magnetic drain plug. Of the remaining holes on the sides of the reducer, use a plug in the upper housing half for the minimum oil level plug.

Table 25 - Approx. Oil Capacity in Quarts ■ ◆

Reducer Size TXT SCXT HXT	Reducer Positions					
	Horizontal				Vertical	
	A	B	C	D	E	F
109,115,125	1/2	1/2	5/8	3/4	1	1-1/4
105	5/8	3/4	5/8	3/4	1-1/8	1-3/8
209,215,225	7/8	1	5/8	1	1-5/8	1-3/4
205	3/4	7/8	7/8	7/8	1-3/4	2-1/4
309,315,325	1-1/2	1-1/2	3/4	2-1/4	2-5/8	3
305	7/8	1-1/2	1-3/8	1-3/8	2-1/2	3-1/8
409,415,425	1-7/8	2-1/4	1-1/4	1-3/4	3-3/8	4-1/4
405	1-1/2	2-1/4	2-1/8	1-7/8	4	4-7/8
509,515,525	3-1/4	4	3-1/4	4	7	8-5/8
505	3-3/8	4-1/4	3-7/8	3-3/4	7-3/4	9
609, 615, 625	4-1/4	5	4-1/4	5	8-5/8	9-1/8
605	4-1/2	5-3/4	4-1/2	5	12	11
709,715,725	6-1/2	8	7-1/4	9-1/4	15-3/8	16-3/8
705	7-1/2	9	7-1/2	9-1/4	19	17-1/4
815,825	8-1/2	11	10-1/2	8-1/2	19-1/8	19-1/8
805	6	15	10	8-1/2	22	18-3/4
915,926	13	13	12-1/2	14-1/4	25-3/8	25-3/8
905	14-3/4	15	16-1/4	13-3/4	31-7/8	31-7/8
10,151,024	23	14	15-3/4	18-3/4	41	41
12,151,225	59	38	59	36-1/2	100	100
TDT1325	86	62	86	59	110	110
TDT1425	120	88	120	61	150	150
TDT1530	197	138	197	170	281	281

■ U.S. Measure: 1 qt. = 32 fluid oz.

◆ Consult DODGE for proper oil level for reducers with backstops and which are mounted in C-position or D-position.

FEATURES/BENEFITS PAGE G2-3	NOMENCLATURE PAGE G2-11	SELECTION/DIMENSIONS PAGE G2-144	RELATED PRODUCTS PAGE G2-152
--------------------------------	----------------------------	-------------------------------------	---------------------------------

ENGINEERING/TECHNICAL



TORQUE-ARM Shaft Mount Speed Reducers

TORQUE-ARM SPEED REDUCER FLANGE MOUNTING AND CLEARANCE DIMENSIONS

TXT Taper Bushed and Straight Bore Reducers can be supplied with mounting pads on the back of the housing which are drilled and tapped to permit bolting the reducer to the supporting framework. Reducers are now provided from the factory with this feature. They can no longer be

field modified. There is no additional charge for the modification. Order flange mount TXT reducers per the part number below. Consult DODGE for delivery. See page G2-205, Tables 32 & 33 or consult DODGE for allowable output shaft overhung loads.

TXT Flange Mount Taper Bushed

Reducers (1) (2) (3)

Part No	Reducer Size	Weight
241415	TXT105T Flange Mount Reducer	40
241417	TXT115T Flange Mount Reducer	45
241419	TXT125T Flange Mount Reducer	45
242415	TXT205T Flange Mount Reducer	52
242417	TXT215T Flange Mount Reducer	58
242419	TXT225T Flange Mount Reducer	58
243620	TXT305AT Flange Mount Reducer	86
243622	TXT315AT Flange Mount Reducer	98
243624	TXT325AT Flange Mount Reducer	98
244381	TXT405AT Flange Mount Reducer	122
244383	TXT415AT Flange Mount Reducer	139
244385	TXT425AT Flange Mount Reducer	139
245341	TXT505AT Flange Mount Reducer	182
245343	TXT515BT Flange Mount Reducer	207
245345	TXT525BT Flange Mount Reducer	207
246428	TXT605T Flange Mount Reducer	251
246430	TXT615T Flange Mount Reducer	285
246432	TXT625T Flange Mount Reducer	285
247431	TXT705T Flange Mount Reducer	410
247433	TXT715T Flange Mount Reducer	462
247435	TXT725T Flange Mount Reducer	462
248414	TXT805T Flange Mount Reducer	557
248416	TXT815T Flange Mount Reducer	633
248418	TXT825T Flange Mount Reducer	633
249414	TXT905T Flange Mount Reducer	668
249416	TXT915T Flange Mount Reducer	760
249418	TXT926T Flange Mount Reducer	760
250416	TXT1015T Flange Mount Reducer	1020
250418	TXT1024T Flange Mount Reducer	1020

(1) Flange mount reducers are Made-to-order with two week cycle time.

(2) Torque-Arm Assembly not included with flange mount reducers.

TXT Flange Mount Straight Bore

Reducers (1) (2) (3)

Part No	Reducer Size	Weight
241416	TXT105S Flange Mount Reducer	40
241418	TXT115S Flange Mount Reducer	45
241420	TXT125S Flange Mount Reducer	45
242416	TXT205S Flange Mount Reducer	52
242418	TXT215S Flange Mount Reducer	58
242420	TXT225S Flange Mount Reducer	58
243621	TXT305AS Flange Mount Reducer	86
243623	TXT315AS Flange Mount Reducer	98
243625	TXT325AS Flange Mount Reducer	98
244382	TXT405AS Flange Mount Reducer	122
244384	TXT415AS Flange Mount Reducer	139
244386	TXT425AS Flange Mount Reducer	139
245342	TXT505AS Flange Mount Reducer	182
245344	TXT515BS Flange Mount Reducer	207
245346	TXT525BS Flange Mount Reducer	207
246429	TXT605S Flange Mount Reducer	251
246431	TXT615S Flange Mount Reducer	285
246433	TXT625S Flange Mount Reducer	285
247432	TXT705S Flange Mount Reducer	410
247434	TXT715S Flange Mount Reducer	462
247436	TXT725S Flange Mount Reducer	462
248415	TXT805S Flange Mount Reducer	557
248417	TXT815S Flange Mount Reducer	633
248419	TXT825S Flange Mount Reducer	633
249415	TXT905S Flange Mount Reducer	668
249417	TXT915S Flange Mount Reducer	760
249419	TXT926S Flange Mount Reducer	760
250417	TXT1015S Flange Mount Reducer	1020
250419	TXT1024S Flange Mount Reducer	1020

(3) TDT13-TDT15 reducers are supplied from stock already drilled and tapped for flange mounting. See page G2-67 thru G2-69.

FEATURES/BENEFITS
PAGE G2-3

NOMENCLATURE
PAGE G2-11

SELECTION/DIMENSIONS
PAGE G2-144

RELATED PRODUCTS
PAGE G2-152



TORQUE-ARM Shaft Mount Speed Reducers

TORQUE-ARM SPEED REDUCER FLANGE MOUNTING PADS AND CLEARANCE DIMENSIONS

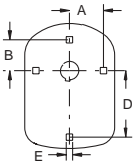

FIG. 1

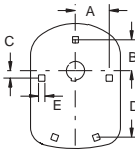

FIG. 2

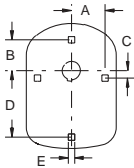

FIG. 3

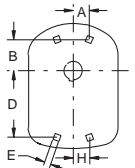

FIG. 4

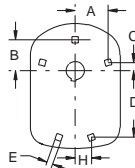

FIG. 5

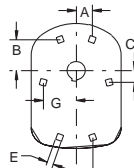

FIG. 6

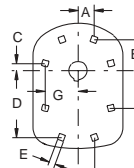

FIG. 7

TABLE 28 - FLANGE MOUNTING DRILLING DIMENSIONS FOR TXT REDUCERS

Reducer Size	Nominal Ratio	Reference	A	B	C	D	E	F	G	H	Tap Size	Tap Drill Depth	Tap Depth
TXT1	5, 9, 15, 25	Fig. 1	2-13/16	3	5-1/2	7/8	7/16 -14	29/32	17/32
TXT2	9, 15, 25	Fig. 1	3-3/8	3-5/16	5-7/8	13/16	7/16 -14	7/8	1/2
TXT2	5	Fig. 2	3-3/8	3-5/16	4-7/8	7/8	2-17/32	7/16 -14	7/8	1/2
TXT3	9, 15, 25	Fig. 3	3-5/8	3-5/16	7/8	6-3/16	1-1/4	1/2-13	1	5/8
TXT3	5	Fig. 2	3-7/8	3-5/16	1	5-19/32	3/4	2-11/16	1/2-13	29/32	17/32
TXT4	5, 9, 15, 25	Fig. 3	3-5/8	3-7/8	2	7-5/8	1	1/2-13	1	5/8
TXT5	9, 15, 25	Fig. 3	4-5/8	4-9/16	2-9/32	9-1/2	1-1/4	5/8-11	7/8	7/16
TXT5	5	Fig. 3	4-5/8	4-9/16	2-9/32	9-1/4	1-1/4	5/8-11	7/8	7/16
TXT6	5, 9, 15, 25	Fig. 3	6-3/16	5-1/8	2-3/16	11	1-7/8	5/8-11	1-1/8	11/16
TXT7	5, 9, 15, 25	Fig. 3	5-5/8	6-1/4	2-15/16	13-1/4	2	3/4-10	1-3/8	7/8
TXT8	5, 15, 25	Fig. 3	6-5/16	7	3	15-1/16	2	3/4-10	1-11/32	27/32
TXT9	15, 26	Fig. 4	5-7/16	5-15/16	16-7/8	2	3-3/8	3/4-10	1-1/32	17/32
TXT9	5	Fig. 5	8-1/16	8-1/16	5/8	13-7/8	2	7-15/16	3/4-10	1-1/32	15/16
TXT10	15, 24	Fig. 6	5-13/16	7-15/16	3-1/2	19	2	9-13/16	3-1/8	3/4-10	1-7/32	23/32
TXT12	15, 25	Fig. 6	6-1/8	10-3/4	7-1/4	22-11/16	2-1/2	12-9/16	9-1/16	3/4-10	1-25/32	1-9/32
TDT13	25	Fig. 6	7-5/16	12-3/4	6-1/2	25-3/4	2-1/2	15-3/4	7-5/16	1-8	2-3/8	1-3/4
TDT14	25	Fig. 7	8-1/4	12-3/4	1-1/4	28-1/4	2-1/2	16-3/4	18-1/16	1-8	2-5/8	2
TDT15	30	Fig. 7	11	15-1/8	1-1/4	32-3/8	3-1/2	19-5/8	22	1-8	2-5/8	2

TABLE 29 - FLANGE MOUNTING CLEARANCE DIMENSIONS

Reducer Size	Nominal Ratio	J	K	L	M	N	P	Q	R	Reducer Size	Nominal Ratio	J	K	L	M	N	P	Q	R
TXT1	9, 15, 25	3-1/4	2-9/16	3-3/16	3-3/16	1-29/32	2-17/32	TXT7	9, 15, 25	9-1/8	5-1/16	4-11/16	8-5/16	8-5/32	5-1/8	6-3/4
TXT1	5	3-1/4	2-13/16	3-3/4	3-1/4	TXT7	5	9-1/8	5-1/16	8-5/16
TXT2	9, 15, 25	4-1/16	3-1/2	3-3/4	3-3/4	2-1/8	3	TXT8	15, 25	9-1/2	7-5/8	6	9-1/2	9-1/2	6-1/32	7-23/32
TXT2	5	4-1/16	3-1/2	3-7/8	TXT8	5	9-1/2	7-1/2	9-41/64
TXT3	9, 15, 25	4-3/8	3-1/2	2-11/16	4-3/16	4-3/16	2-5/16	3-5/16	TXT9	15, 26	10-15/16	8	8	10-13/16	10-13/16	6-19/32	8-5/8
TXT3	5	4-3/8	3-1/2	4-1/4	TXT9	5	10-15/16	8	10-31/32
TXT4	9, 15, 25	4-13/16	3-7/8	3-1/4	4-25/32	4-25/32	2-3/4	3-11/16	TXT10	15, 24	12-1/4	8	7-5/8	12-1/2	12-1/2	6-9/16	8-23/32
TXT4	5	4-13/16	4-1/16	4-7/8	TXT12	15, 25	14-1/4	8-5/8	9	22-29/32	13-25/32	5-9/16	11-1/8
TXT5	9, 15, 25	5-5/8	4-1/4	3-1/4	5-11/16	5-21/32	3-1/16	4-9/16	TDT13	25	15-5/8	8-5/8	10-1/4	24-27/64	14-15/32	6-5/16	12-5/8
TXT5	5	5-5/8	4-3/4	5-7/8	TDT14	25	17-5/8	10-3/4	11-3/4	26-9/32	15-5/16	7-1/8	14-1/4
TXT6	9, 15, 25	8-1/8	5-1/16	4	6-3/4	6-23/32	4-3/32	5-5/8	TDT15	30	22-1/2	10-3/4	13-1/2	30-9/16	18-1/8	8	16
TXT6	5	8-1/8	5-1/16	6-7/8										

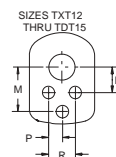
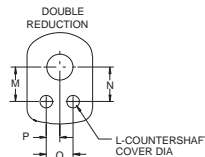
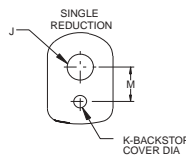

FEATURES/BENEFITS PAGE G2-3	NOMENCLATURE PAGE G2-11	SELECTION/DIMENSIONS PAGE G2-144	RELATED PRODUCTS PAGE G2-152
--------------------------------	----------------------------	-------------------------------------	---------------------------------



ENGINEERING/TECHNICAL

TORQUE-ARM Shaft Mount Speed Reducers

OPTIONAL TORQUE-ARM ROD MOUNTING POSITIONS FOR TORQUE-ARM REDUCERS

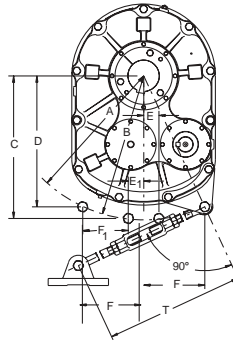

DOUBLE REDUCTION
TORQUE-ARM REDUCERS

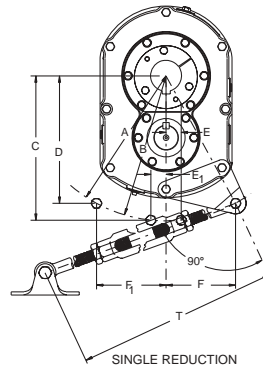

SINGLE REDUCTION
TORQUE-ARM REDUCERS

TABLE 26 - TORQUE-ARM ROD OPTIONAL MOUNTING POSITIONS FOR TXT1 THRU TXT10 DOUBLE REDUCTION REDUCERS

REDUCER SIZE	A-RADIUS	B-RADIUS	C	D	E, E ₁	F, F ₁	T	
							MIN.	MAX.
TXT1	8.00	-	-	7.25	-	3.41	23.81	29.63
TXT2	8.75	9.00	8.94	7.50	0.81	4.50	26.94	32.94
TXT3A	10.16	10.38	10.31	8.88	0.97	4.94	26.94	32.94
TXT4A	11.47	11.84	11.78	10.06	1.09	5.50	29.19	35.19
TXT5B	13.75	14.03	13.97	12.06	1.00	6.63	29.19	35.19
TXT6	15.69	15.88	15.84	13.63	0.94	7.75	29.19	35.19
TXT7	18.19	18.84	18.81	15.88	1.25	8.94	29.44	35.44
TXT8	21.00	21.38	21.38	19.56	-	7.63	30.00	36.00
TXT9	22.72	23.63	23.63	20.63	-	9.50	30.00	36.00
TXT10	25.20	25.56	25.56	23.56	-	8.94	30.00	36.00

TABLE 27 - TORQUE-ARM ROD OPTIONAL MOUNTING POSITIONS FOR TXT105 THRU TXT905 SINGLE REDUCTION REDUCERS

REDUCER SIZE	A-RADIUS	B-RADIUS	C	D	E, E ₁	F, F ₁	T	
							MIN.	MAX.
TXT105	8.00	-	-	7.25	-	3.41	23.81	29.63
TXT205	8.75	9.00	8.94	7.50	0.81	4.50	26.94	32.94
TXT305A	10.16	10.38	10.31	8.88	0.97	4.94	26.94	32.94
TXT405A	11.47	11.84	11.78	10.06	1.09	5.50	29.19	35.19
TXT505A	14.53	14.81	14.78	12.59	0.91	7.25	29.19	35.19
TXT605	16.44	16.66	16.63	14.22	0.88	8.22	29.19	35.19
TXT705	18.19	18.84	18.81	15.88	1.25	8.94	29.44	35.44
TXT805	21.00	21.38	21.38	19.56	-	7.63	30.00	36.00
TXT905	22.70	23.63	23.63	20.63	-	9.50	30.00	36.00

It is preferred to mount the TORQUE-ARM rod in tension. However, the design allows mounting in compression as well. If mounted in compression, observe the tolerance $\pm 20^\circ$ to the 90° referenced above, to minimize bending. The housing direction will be opposite to the direction of output or driven shaft rotation.

FEATURES/BENEFITS PAGE G2-3	NOMENCLATURE PAGE G2-11	SELECTION/DIMENSIONS PAGE G2-144	RELATED PRODUCTS PAGE G2-152
--------------------------------	----------------------------	-------------------------------------	---------------------------------



TORQUE-ARM Shaft Mount Speed Reducers

MACHING DIMENSIONS FOR TXT1 THRU TXT5B AND TXT105 THRU TXT505A TACONITE AUBILIARY SEAL KITS

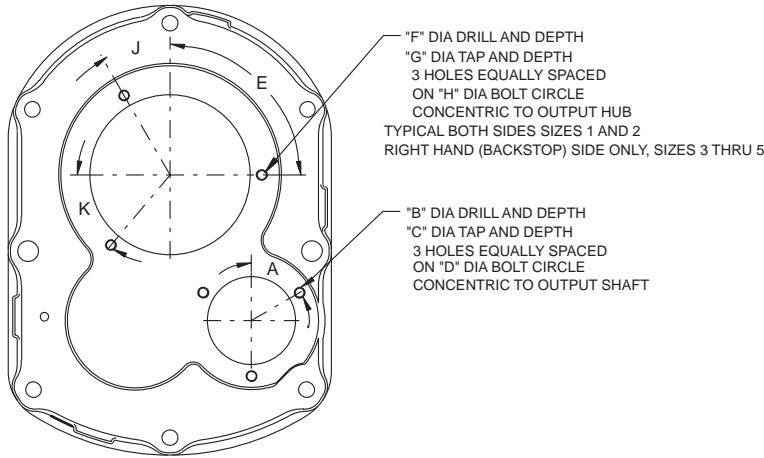

TABLE 1 - REDUCER MACHING DIMENSIONS FOR TACONITE AUXILIARY SEAL KITS

REDUCER SIZE	A (DEGREES)	B ▲ (INCHES)	C (INCHES)	D (INCHES)	E (DEGREES)	F ▲ (INCHES)	G (INCHES)	H (INCHES)	J (DEGREES)	K (DEGREES)
TXT1	60°	NO. 7 DIA .75 DEEP	1/4-20.50 DEEP	2.63	120°	NO.7 DIA .75 DEEP	1/4-20.50 DEEP	4.13	N/A	N/A
TXT2	60°	NO. 7 DIA .81 DEEP	1/4-20.56 DEEP	2.94	120°	NO.7 DIA .88 DEEP	1/4/2020 .56 DEEP	4.75	N/A	N/A
TXT3A	N/A	★	★	★	90°	NO.F DIA .75 DEEP	5/16/2018 .53 DEEP	5.25	305	505
TXT4A	N/A	★	★	★	30°	5/16 DIA .94 DEEP	3/8/2016 .56 DEEP	6.00	905	1305
TXT5B	N/A	★	★	★	90°	5/16 DIA .94 DEEP	3/8/2016 .56 DEEP	6.63	305	605
TXT105	60°	NO. 7 DIA .75 DEEP	1/4-20 .50 DEEP	2.94	120°	NO.7 DIA .75 DEEP	1/4/2020 .50 DEEP	4.13	N/A	N/A
TXT205	60°	NO. 7 DIA .81 DEEP	1/4-20. 56 DEEP	3.69	120°	NO.7 DIA .88 DEEP	1/4/2020 .63 DEEP	4.75	N/A	N/A
TXT305A	N/A	★	★	★	90°	NO.F DIA .75 DEEP	5/16/2018 .53 DEEP	5.25	305	505
TXT405A	N/A	★	★	★	30°	5/16 DIA .94 DEEP	3/8/2016 .56 DEEP	6.00	905	1305
TXT505A	N/A	★	★	★	90°	5/16 DIA .94 DEEP	3/8/2016 .56 DEEP	6.63	305	605

▲ DRILL DEPTH IS MAXIMUM AND MUST NOT BE EXCEEDED

★ PLACE AUXILIARY SEAL COVER ON INPUT SEAL CARRIER USING BOLTS PROVIDED

N/A = NOT APPLICABLE

FEATURES/BENEFITS PAGE G2-3	NOMENCLATURE PAGE G2-11	SELECTION/DIMENSIONS PAGE G2-144	RELATED PRODUCTS PAGE G2-152
--------------------------------	----------------------------	-------------------------------------	---------------------------------

ENGINEERING/TECHNICAL



TORQUE-ARM Shaft Mount Speed Reducers SLOTTED METAL PANEL BELT GUARD SPECIFICATION FOR TXT/SCXT REDUCERS

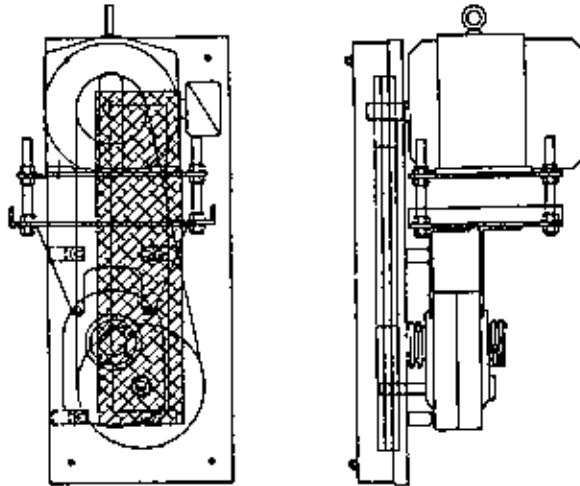

STYLE:	Rectangular box type Solid metal base, top and side panels. Slotted metal front and bottom panels
MATERIAL TYPE:	Hot-rolled, pickled-in-oil, #A569 Steel sheet metal.
MATERIAL THICKNESS:	Body -- 14 gauge Mounting Straps TXT1 thru TXT7 -- 7 gauge TXT8 thru TXT10 -- 1/4" gauge
FINISH:	One coat yellow paint
MOUNTING:	Mounting straps, welded to outside of back panel, fasten guard to reducer housing and motor mount front support. Threaded studs welded to inside of back panel fasten expanded metal panel into place.
FASTENERS:	Grade 5 steel

FEATURES/BENEFITS
PAGE G2-3

NOMENCLATURE
PAGE G2-11

SELECTION/DIMENSIONS
PAGE G2-144

RELATED PRODUCTS
PAGE G2-152



TORQUE-ARM Shaft Mount Speed Reducers

Table 31 - Maximum Input and Driven Speeds for TXT and SCXT Reducers

SINGLE REDUCTION			DOUBLE REDUCTION													
Reducer Size	Input	Driven	Reducer Size	Input RPM			Driven RPM			Reducer Size	Input RPM			Driven RPM		
				Nominal Ratio			Nominal Ratio				Nominal Ratio			Nominal Ratio		
				9	15	25	9	15	25		15	25	30	15	25	30
TXT/SCXT1	2248	400	TXT/SCXT1	1888	2149	2179	200	140	85	TXT/SCXT8	1809	1847	120	75	..
TXT/SCXT2	2116	400	TXT/SCXT2	1850	1974	1994	200	140	85	TXT9	1814	1925	120	75	..
TXT/SCXT3	2240	400	TXT/SCXT3	1782	2083	2100	200	140	85	TXT10	1819	1823	120	75	..
TXT/SCXT4	2260	400	TXT/SCXT4	1934	2118	2072	200	140	85	TXT12	1786	1849	120	75	..
TXT/SCXT5	2268	400	TXT/SCXT5	1790	1925	2044	200	125	85	TDT13	1855	75	..
TXT/SCXT6	2268	400	TXT/SCXT6	1840	1916	2010	200	125	85	TDT14	1860	75	..
TXT/SCXT7	2144	400	TXT/SCXT7	1922	1827	1844	200	120	75	TDT15	1746	57	..
TXT8	2200	400														
TXT9	2154	400														

Table 32 - Output Shaft Overhung Load Ratings for Double Reduction TXT Reducers

Reducer Size	Nominal Ratio	Shaft Size	Overhung Load (Lbs.) @ Various RPM's *										
			10	20	30	50	80	100	120	140	160	180	200
TXT1	9, 15, 25	1-1/4	1990	1520	1300	1100	930	780	760	740	720	700	680
		1-7/16	1700	1300	1110	945	790	665	650	640	630	620	610
TXT2	9, 15, 25	1-7/16	2000	1510	1270	1010	840	820	720	720	710	710	700
		1-15/16	1750	1320	1110	890	730	710	630	630	620	620	610
TXT3	9, 15, 25	1-15/16	5400	4250	3680	3050	2620	2440	2310	2210	2110	2040	1980
		2-3/16	5240	4120	3570	2960	2540	2370	2240	2140	2050	1980	1920
TXT4	9, 15, 25	2-3/16	6520	5180	4510	3800	3230	3000	2830	2710	2600	2510	2430
		2-7/16	6360	5060	4410	3710	3160	2930	2770	2640	2530	2450	2370
TXT5	9, 15, 25	2-7/16	7460	5860	5080	4280	3690	3450	3270	3110	2980	2880	2790
		2-15/16	7060	5540	4800	4040	3490	3260	3090	2940	2820	2720	2640
TXT6	9, 15, 25	2-15/16	9100	7100	6100	5000	4100	4050	3700	3550	3400	3300	3200
		3-7/16	8200	6400	5500	4500	3700	3650	3400	3300	3250	3200	3150
TXT7	9, 15, 25	3-7/16	11,400	9500	7300	5950	4750	5050	4500	4300	4250	4200	4150

Values shown are for loads applied at one output shaft diameter from reducer bushing. Interpolate for values between RPM's listed.

Table 33 - Output Shaft Overhung Load Ratings for Single Reduction TXT Reducers

Reducer Size	Nominal Ratio	Shaft Size	Overhung Load (Lbs.) @ Various RPM's *						
			100	150	200	250	300	350	400
TXT1	5	1-1/4	775	610	600	500	500	500	490
		1-7/16	660	520	520	430	430	420	420
TXT2	5	1-7/16	760	620	530	530	530	530	520
		1-15/16	665	545	470	470	470	460	460
TXT3	5	1-15/16	2370	2100	1950	1840	1760	1700	1660
		2-3/16	2300	2040	1890	1780	1710	1650	1610
TXT4	5	2-3/16	3030	2720	2490	2310	2170	2060	1970
		2-7/16	2930	2640	2400	2240	2100	1990	1900
TXT5	5	2-7/16	3080	2750	2560	2400	2260	2160	2080
		2-15/16	2920	2610	2430	2270	2140	2050	1980
TXT6	5	2-15/16	4350	3850	3500	3250	3200	3100	3050
		3-7/16	3950	3500	3200	2950	2900	2800	2750
TXT7	5	3-7/16	3800	3650	3300	3450	3500	3400	3300

* Values shown are for loads applied at one output shaft diameter from reducer bushing. Interpolate for values between RPM's listed.

Table 1 - WR² (Lb.-FT²) At High Speed Shaft for TXT Reducers *

Reducer Size	Nominal Ratio				Reducer Size	Nominal Ratio			
	5:1	9:1	15:1	25:1		5:1	9:1	15:1	25:1
TXT1	0.002	0.013	0.008	0.007	TXT9	1.66	...	1.39	0.794
TXT2	0.013	0.027	0.011	0.007	TXT10	1.63	0.927
TXT3	0.034	0.059	0.026	0.013	TXT12	7.71	3.68
TXT4	0.075	0.092	0.043	0.023	TDT13	6.56
TXT5	0.15	0.233	0.099	0.067	TDT14	9
TXT6	0.201	0.461	0.197	0.109	TDT15	11.42
TXT7	0.48	1.004	0.417	0.285					
TXT8	0.96	...	0.942	0.571					

* For WR² at low speed shaft, multiply WR² value listed by (actual ratio)².

FEATURES/BENEFITS PAGE G2-3	NOMENCLATURE PAGE G2-11	SELECTION/DIMENSIONS PAGE G2-144	RELATED PRODUCTS PAGE G2-152
--------------------------------	----------------------------	-------------------------------------	---------------------------------

ENGINEERING/TECHNICAL



TORQUE-ARM Shaft Mount Speed Reducers THRUST CAPACITY OF SCREW CONVEYOR DRIVE REDUCERS

The screw conveyor drive reducer uses tapered roller bearings which take thrust in either direction from the

screw conveyor. This eliminates the need for external thrust bearings commonly used.

TABLE 1 - THRUST CAPACITY OF SCREW CONVEYOR DRIVE REDUCERS (POUNDS) •

Reducer Size	Screw Conveyor RPM						
	80	100	120	140	160	180	200
SCXT109	3986	3765	3588	3434	3303	3192	3092
SCXT209	5389	5025	4742	4505	4304	4138	3990
SCXT309A	5290	4920	4660	4450	4240	4100	3970
SCXT409A	6000	6000	5800	5500	5200	5000	5000
SCXT509B	6000	6000	6000	6000	5800	5700	5500
SCXT609	6000	6000	6000	6000	6000	6000	6000
SCXT709	4863	4527	4244	3959	3713	3520	3335

Reducer Size	Screw Conveyor RPM					
	25	50	75	100	125	140
SCXT115	6000	4840	4220	3820	3540	3414
SCXT215	6000	6000	5440	4920	4560	4380
SCXT315A	6000	6000	5400	4920	4600	4450
SCXT415A	6000	6000	6000	6000	5800	5600
SCXT515B	6000	6000	6000	6000	6000
SCXT615	6000	6000	6000	6000	6000
SCXT715 †	6000	6000	5220	4530

Reducer Size	Screw Conveyor RPM				
	25	50	75	80	85
SCXT125	6000	4840	4220	4130	4040
SCXT225	6000	6000	5440	5320	5000
SCXT325A	6000	6000	5400	5290	5200
SCXT425A	6000	6000	6000	6000	6000
SCXT525B	6000	6000	6000	6000
SCXT625	6000	6000	6000	6000
SCXT725	6000	6000	5220

Reducer Size	Screw Conveyor RPM						
	100	150	200	250	300	350	400
SCXT105	6000	5500	5060	4730	4520	4340	4200
SCXT205	5310	4760	4390	4160	3970	3810	3680
SCXT305A	6000	5300	4900	4600	4400	4300	4200
SCXT405A	6000	5900	5500	5000	4600	4500	4500
SCXT505B	6000	6000	6000	6000	5700	5400	5000
SCXT805	6000	6000	6000	6000	6000	6000	6000
SCXT705	5860	5500	4810	4710	4830	4980	4900

† Actual maximum output speed for SCXT715 reducer is 120 rpm
 • Consult DODGE for SCXT8 thrust capacity

FEATURES/BENEFITS PAGE G2-3	NOMENCLATURE PAGE G2-11	SELECTION/DIMENSIONS PAGE G2-144	RELATED PRODUCTS PAGE G2-152
--------------------------------	----------------------------	-------------------------------------	---------------------------------



TORQUE-ARM Shaft Mount Speed Reducers GUIDELINES FOR LONG-TERM STORAGE OF TORQUE-ARM REDUCERS

During periods of long storage (3 months or more), or when awaiting delivery or installation of other equipment, special care should be taken to protect a gear reducer to have it in the best condition when placed into service.

By taking special precautions, problems such as seal leakage and reducer failure due to the lack of lubrication, improper lubrication quantity, or contamination can be avoided. The following precautions will protect gear reducers during periods of extended storage.

PREPARATION

1. Drain the oil from the unit. Add a vapor phase corrosion inhibiting oil such as VCI-105 oil by Daubert Chemical Co.
2. Seal the unit air tight. Replace the vent plug with a standard pipe plug and wire the vent to the unit.
3. Cover the shaft extension with a waxy rust preventive compound that will keep oxygen away from the bare metal such as Non-Rust X-110 by Daubert Chemical Co.

4. The instruction manuals and lubrication tags are paper and must be kept dry. Either remove these documents and store them inside or cover the unit with a durable waterproof cover which can keep moisture away.
5. Protect the reducer from dust, moisture, and other contaminants by storing the unit in a dry area.
6. In damp environments, the reducer should be packed inside a moisture-proof container or an envelope of plastic containing a desiccant material. If the reducer is to be stored outdoors, cover the entire exterior with a rust preventive.
7. reducer is to be stored outdoors, cover the entire exterior with a rust preventive.
8. Once a month rotate the input shaft at least 30 revolutions to redistribute the weight of gears and shafts and to prevent brinnelling of the bearings and drying of the seal track.

TABLE 1 - VCI #105 OIL FOR TORQUE-ARM REDUCERS

CASE SIZE	QUARTS OR LITERS
TXT1	0.1
TXT2	0.1
TXT3	0.1
TXT4	0.2
TXT5	0.3
TXT6	0.4
TXT7	0.5
TXT8	0.6
TXT9	0.9
TXT10	1.3
TXT11	1.9
TXT12	2.5

VCI #105 & #10 are interchangeable, but VCI #105 is more readily available.

WHEN PLACING THE REDUCER INTO SERVICE

1. Assemble the vent plug into the proper hole.
2. Clean the shaft extensions with petroleum solvents.
3. Fill the unit to the proper oil level using a recommended lubricant. The VCI oil will not affect the new lubricant.
4. Follow the installation instructions provided with the unit.

ENGINEERING/TECHNICAL



TORQUE-ARM Shaft Mount Speed Reducers TROUBLE-SHOOTING GUIDE FOR TORQUE-ARM REDUCERS

SYMPTOM	PROBABLE CAUSE	REMEDY
Excessive Noise and Vibration	Improper arm attachment.	Check instructions and correct. Tighten all fasteners properly.
	Low oil level.	Check level. Fill to proper oil capacity per instruction manual.
	Excessive premature gear wear due to improper size reducer.	Reselect reducer in catalog with proper service factor. Replace worn unit.
	Driven shaft undersized.	Replace shaft or remachine to properly fit next smaller bushing size. (Check shaft strength.)
	Driven shaft bent.	Check runout. Replace or straighten shaft.
	Worn gears and bearings.	Replace gears and bearings as necessary.
	Driven shaft not projecting through output bore or bushings.	Reposition reducer on shaft or replace shaft.
	Tapered reducer bushings improperly tightened.	Check instruction manual and tighten per recommended torque values.
	Improper connection to driver and driven equipment.	Check belt tension and V-belt sheave alignment. Check coupling alignment. Check all fasteners and setscrews; tighten properly. Inspect driven shaft key positioning.
	Worn or cracked V-belts.	Replace with new belts.
Overheating Reducers (Exceeds 195F Housing Temperature).	Driven equipment noise.	Check for source, reducer may amplify existing noise.
	Improper oil level	Check oil and fill to proper oil capacity per instruction manual. Too much oil causes heat due to churning and friction; too little starves components.
	Improper reducer size.	Reselect reducer in catalog. Decrease load or replace reducer with proper unit.
	Excessive V-belt tension.	Tension belts properly. Position sheaves as close to reducer as possible.
	Excessive reducer operating speed.	Check catalog recommendations. If necessary refer all application details to manufacturer.
	Located near high ambient heat source.	Shield reducer from heat source. Relocate reducer. Refer application details to manufacturer.
Oil Leakage	No cooling fan installed.	Check catalog recommendation. Install fan if required.
	Undetermined source of leak.	Clean reducer and dry all surfaces. Run for one hour and inspect for leak from seals, gaskets, covers and plugs.
	Plugged breather air passage.	Clean air passage. Remove air passage tape on new reducers.
	Loose drain, breather or pipe plugs.	Tighten securely. Check oil level.
	Excessive oil level.	Check level. Fill to proper oil capacity per instruction manual.
	Breather plug below oil.	Relocate breather to highest location. Check oil level.
Excessive Backlash	Premature seal wear due to hostile environment.	Replace seals. Install auxiliary seal kit.
	Worn gears.	Replace worn gears in sets.
	Loose bearings.	Check bearing wear, adjustment and replace.
	Worn shaft keys.	Replace worn keys. Check shaft keyways for wear.
	Driven equipment backlash.	Check equipment for backlash.

FEATURES/BENEFITS
PAGE G2-3

NOMENCLATURE
PAGE G2-11

SELECTION/DIMENSIONS
PAGE G2-144

RELATED PRODUCTS
PAGE G2-152



TORQUE-ARM Shaft Mount Speed Reducers TROUBLE-SHOOTING GUIDE FOR TORQUE-ARM REDUCERS (CONT'D)

SYMPTOM	PROBABLE CAUSE	REMEDY
Excessive Lateral Movement	Worn and loose bearings	Replace bearings.
	Improper bearing adjustment.	Readjust bearing per instruction manual.
	Loose bearing carrier caps.	Check and tighten fasteners.
	Improper reducer mounting.	Check and tighten straight bore reducer set screws to recommended torque values. Check and tighten tapered reducer bearing fasteners to recommended torque values. See instruction manual.
	Reversing duty applications.	Refer application details to manufacturer.
Excessive Reducer Wobble	Driven shaft undersized.	Replace shaft or remachine to properly fit next smaller bushing size. (Check shaft strength.)
	Driven shaft bent.	Check runout. Replace or straighten shaft.
	Improper torque arm attachment.	Check instructions and correct. Tighten all fasteners promptly.
	Driven shaft not projecting through output bore or bushings.	Reposition reducer on shaft or replace shaft.
	Worn or loose driven shaft key.	Check for proper size and replace. Check shaft keyway size.
Reducer Shafts Will Not Rotate	Improper backstop installation.	Remove backstop and install properly. (Rotate end for end.)
	Driven equipment locked.	Check for rotation of driven equipment.
	Damaged gearing	Check gearing and replace. Inspect driven equipment and check for rotation.
Premature Input Bearing Failure	Excessive V-belt tension	Tension V-belts properly.
	Excessive overhung load.	Mount sheave as close to reducer as possible. Check minimum sheave requirement and replace if necessary.
	Improper oil level.	Check oil and fill to proper oil capacity per instruction manual.
	Excessive reducer operating speed.	Check catalog recommendations. If necessary, refer application details to manufacturer.
Premature Backstop Wear or Backstop Slips	Improper oil	Check oil. Avoid lubricants with EP additives, e.g., graphite. Check instruction manual for proper type.
	Backstop wear.	Check wear and replace. Inspect periodically.
	Excessive input shaft lateral movement.	Check for bearing, shaft, and housing wear. Replace components and readjust reducer per instruction manual.
	Excessive V-belt tension.	Tension V-belts properly.
	Excessive overhung load.	Mount sheave as close to reducer as possible. Check minimum sheave requirement and replace if necessary.
	Backstop key not installed	Install key or keys.
	Improper installation.	Check for proper direction of shaft rotation in backstop.
	Improper input bearing adjustment	Readjust bearings per instruction manual.
	Contaminated oil.	Flush reducer and replace oil.
Excessive reducer operating speed.	Check catalog recommendations. Refer application details to manufacturer.	

Consult DODGE for other applications.

FEATURES/BENEFITS PAGE G2-3	NOMENCLATURE PAGE G2-11	SELECTION/DIMENSIONS PAGE G2-144	RELATED PRODUCTS PAGE G2-152
--------------------------------	----------------------------	-------------------------------------	---------------------------------



TORQUE-ARM Shaft Mount Speed Reducers REPLACEMENT INTERCHANGE TXT SERIES EQUIVALENTS

FOUR GENERATIONS OF DODGE TORQUE-ARM REDUCERS

AGMA CASE SIZE	RATIO										
	5:1		9:1	15:1			25:1				
-	#10	#10	-	-	-	TD015	-	-	TD025	-	-
107	#11	T11	TXT105	TXT109	#1	TD115	TDT115	TXT115	TD125	TDT125	TXT125
115	#12	T12	TXT205	TXT209	#2	TD215	TDT215	TXT215	TD225	TDT225	TXT225
203	#13	T13	TXT305	TXT309	#3	TD315	TDT315	TXT315	TD325	TDT325	TXT325
207	#14	T14	TXT405	TXT409	#4	TD415	TDT415	TXT415	TD425	TDT425	TXT425
215	#15	T15	TXT505	TXT509	#5	TD515	TDT515	TXT515	TD525	TDT525	TXT525
307	#16	T16	TXT605	TXT609	#6	TD615	TDT615	TXT615	TD625	TDT625	TXT625
315	#17	T17	TXT705	TXT709	#7	TD715	TDT715	TXT715	TD725	TDT725	TXT725
407	#18	T18	TXT805	-	#8	TD815	TDT815	TXT815	TD825	TDT825	TXT825
415	#19	T19	TXT905	-	#9	TD915	TDT915	TXT915	TD926	TDT926	TXT926
507	-	-	-	-	-	TD1015	TDT1015	TXT1015	TD1024	TDT1024	TXT1024
-	-	-	-	-	-	-	TDT1115	-	TD1125	TDT1125	-
608	-	-	-	-	-	-	TDT1215	TXT1215	TD1225	TDT1225	TXT1225
700	-	-	-	-	-	-	-	-	TD1325	TDT1325	TDT1325
800	-	-	-	-	-	-	-	-	TD1425	TDT1425	TDT1425
1000	-	-	-	-	-	-	-	-	-	TDT1530	TDT1530

Notes:

1. The "#" series and TD DODGE TORQUE-ARM reducers were manufactured with straight bore mountings only. The TDT and current TXT DODGE TORQUE-ARM reducers were/are manufactured with both straight bore and twin tapered bore bushings.
2. With the increased HP ratings of the TXT reducer, it may be possible to downsize to a smaller gearbox when replacing an old-style DODGE TORQUE-ARM reducer. Be sure to review the application.



TORQUE-ARM Shaft Mount Speed Reducers

BACKSTOP INTERCHANGE FOR ALL DODGE TORQUE-ARM REDUCERS

PART NUMBER	NEW TXT SERIES	OLD TXT SERIES	TDT SERIES	TD SERIES	NUMBER SERIES
241101			TDT 115 TDT 125	TD 115 TD 125	No.1
242101		TXT 105 TXT 109 TXT 115 TXT 125	T11 TDT 215 TDT 225	TD 215 TD 225	No. 2 No. 3 No. 11
243101			TDT 315 TDT 325	TD 315 TD 325	
243102		TXT 309 TXT 315 TXT 325			
243106	TXT 309A TXT 315A TXT 325A				
244092			TDT 415 TDT 425	TD 415 TD 425	
244101					No. 4 No. 5
244106	TXT 409A TXT 415A TXT 425A				
244148	TXT 405A	TXT 405 TXT 409 TXT 415 TXT 425			
245101			TDT 515 TDT 525	TD 515 TD 525	
245154	TXT 509B TXT 515B TXT 525B	TXT 509, TXT 509A TXT 515, TXT 515A TXT 525, TXT 525A			
246092		TXT 605 TXT 609 TXT 615 TXT 625	T16 TDT 615 TDT 625	TD 615, TD 615A TD 625, TD 625A	No. 16A

FEATURES/BENEFITS PAGE G2-3	NOMENCLATURE PAGE G2-11	SELECTION/DIMENSIONS PAGE G2-144	RELATED PRODUCTS PAGE G2-152
--------------------------------	----------------------------	-------------------------------------	---------------------------------

ENGINEERING/TECHNICAL**TORQUE-ARM Shaft Mount Speed Reducers****BACKSTOP INTERCHANGE FOR ALL DODGE TORQUE-ARM REDUCERS**

PART NUMBER	NEW TXT SERIES	OLD TXT SERIES	TDT SERIES	TD SERIES	NUMBER SERIES
246101	TXT 505A	TXT 505	T15		No. 6
247092	Use Part Number 247260				
247101					No. 7A
247260		TXT 705 TXT 709 TXT 715 TXT 725	T17 TDT 715 TDT 725	TD 715, TD 715A TD 725, TD 725A	No. 17A
248101	Use Part Number 249260				
249260		TXT 815 TXT 825 TXT 915 TXT 926	TDT 815 TDT 825 TDT 915 TDT 926 TDT 1115 TDT 1125	TD 815, TD 815A TD 825, TD 825A TD 915 TD 926 TD 1115 TD 1125	No. 8 No. 9 No. 18
250101	Use Part Number 250260				
250260		TXT 805 TXT 1015 TXT 1024 TXT 1215 TXT 1225	T18 TDT 1015 TDT 1024 TDT 1215 TDT 1225	TD 1015 TD 1024 TD 1215 TD 1225	
252101		TXT 205 TXT 209 TXT 215 TXT 225 TXT 305	T12 T13		No. 13
	TXT 305A				
254101			T14		No. 14
255101					No. 15
256101					No. 16
257101					No. 17
272259		TXT 905	TDT 1325, T19		
272293			TDT 1425 TDT 1530		



TORQUE-ARM Shaft Mount Speed Reducers SCREW CONVEYOR DRIVE MOUNTING POSITIONS BASED ON SCREW DIAMETER

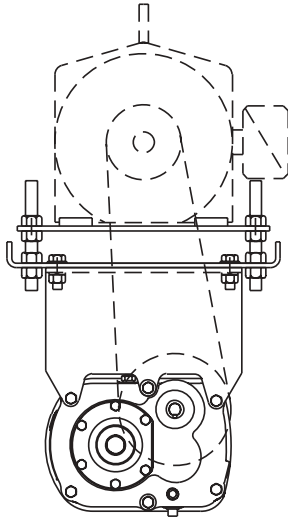

TOP POSITION

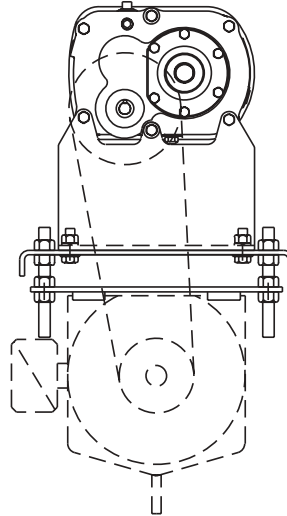

BOTTOM POSITION

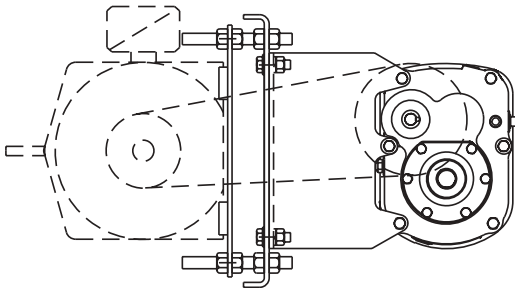

LEFT SIDE POSITION

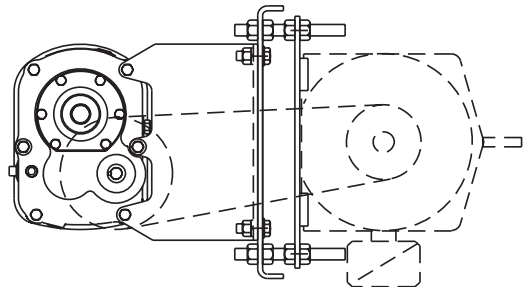

RIGHT SIDE POSITION

Reducer Size	Motor Mount No. ★	For Use on Troughs with Screw Diameters of:	
		Top, Right and Left Side Portions	Bottom Position
SCXT1	M112	6, 9, 12"	6, 9"
SCXT2	M214	6, 9, 12, 14"	6, 9, 12"
SCXT3A	M316	6, 9, 12, 14, 16"	6, 9, 12, 14"
SCXT4A, SCXT5B	"M418, M518"	9, 12, 14, 16, 18"	9, 12, 14, 16"
SCXT6, SCXT7	"M620, M720"	12, 14, 16, 18, 20"	12, 14, 16, 18"

★ Long Series Motor Mount to fit troughs with screws up thru 24, diameter are available from stock.

See pages G2-90 thru G2-119.

FEATURES/BENEFITS PAGE G2-3	NOMENCLATURE PAGE G2-11	SELECTION/DIMENSIONS PAGE G2-144	RELATED PRODUCTS PAGE G2-152
--------------------------------	----------------------------	-------------------------------------	---------------------------------

NOTES



FEATURES/BENEFITS PAGE G2-3	NOMENCLATURE PAGE G2-11	SELECTION/DIMENSIONS PAGE G2-144	RELATED PRODUCTS PAGE G2-152
--------------------------------	----------------------------	-------------------------------------	---------------------------------



MAXUM Concentric Reducers

Features/Benefits	G3-3
Specifications	G3-5
How To Order	G3-6
Nomenclature	G3-6
Easy Selection	
Separate Reducers	G3-7
Scoop Mount Packages	G3-16
Selection/Dimensions	G3-23
Modification/Accessories	G3-34
Related Products	G3-55
Engineering/Technical	G3-57
Part Number Index	INDEX-1
Keyword Index	INDEX-27

NOTES





MAXUM Concentric Reducer

Dodge Maxum - Improved Features - Greater Benefits

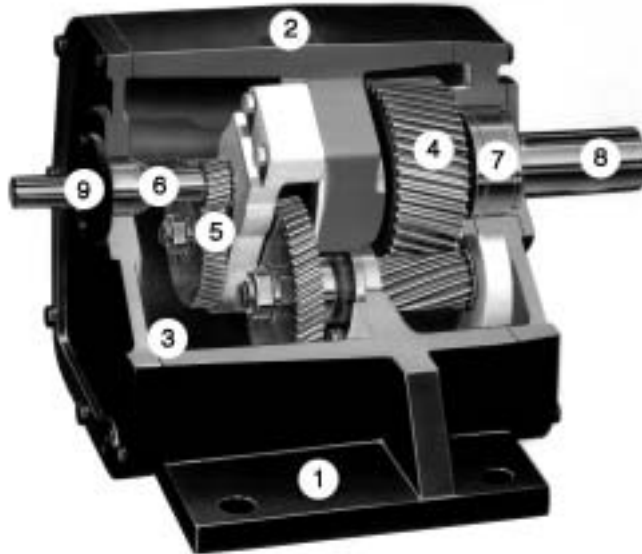

1. Rugged, compact package generates dependable performance in less space.
 - Maximum capacity design
2. High strength, ductile and cast iron housings provide strength and rigidity for industrial applications
 - Finite element modeled
 - Integral internal walls
3. Precision machined, doweled design provides proper gear alignment under load.
4. All new helical gearing with increased capacity reduces cost or extends service life.
 - Case carburized, precision finished teeth
 - Gears and pinions 98% efficient per stage
5. Balanced gear ratios for the most cost-effective design.
6. Large diameter shafts for added strength.
 - Increased shaft diameters for less deflection
7. All heavy-duty tapered roller bearing design for increased performance.
 - Increased radial and thrust load capabilities
 - Minimum 25,000 hours average life
8. Reducer overhung load capability optimized for total system value.
9. Standard, double-lip and optional Viton) seals help keep lubricants in, contaminants out.
 - 100% Factory tested before shipment
 - Standard seal operating temperatures of -40°F to 225°F.



FEATURES/BENEFITS

MAXUM Concentric Reducer



TOTALLY NEW DESIGN WITH DRAMATICALLY INCREASED HORSEPOWER AND HIGHER TORQUE RATINGS, DELIVERS GREATER CONCENTRIC REDUCER VALUE AND 20% COST SAVINGS*

OPTIONS

DODGE MAXUM REDUCER SIZE	RATIOS AVAILABLE	HP@ 1750 RPM 25:1	LOW SPEED SHAFT OHL** @ 68 RPM (lbs)	SCOOP PACKAGES FOR MOTOR FRAMES	CUSTOM DESIGNED HEAVY DUTY BASEPLATES	TOP MOTOR MOUNTS FOR MOTOR FRAMES	EXTERNAL BACKSTOP	AUX. SEALS	VITON® SEAL OPTION	SLIDE BASE
1	2.25-194.6	7.58	2,700	143-215T	YES	143-215T	YES	YES	YES	YES
2	2.25-194.6	13.5	3,790	143-256T	YES	143-256T	YES	YES	YES	YES
3	2.25-194.6	21.7	4,470	143-286T	YES	143-286T	YES	YES	YES	YES
4	2.25-194.6	34.7	5,460	143-326T	YES	143-326T	YES	YES	YES	YES
5	2.25-194.6	43.5	7,130	143-365T	YES	182-365T	YES	YES	YES	YES
6	2.25-194.6	71.0	8,660	143-365T	YES	182-365T	YES	YES	YES	YES
7	5.06-194.6	108	13,100	213-445T	YES	213-445T	YES	YES	YES	YES
8	5.06-194.6	125	14,300	213-445T	YES	213-445T	YES	YES	YES	YES
9	5.06-194.6	189	15,800	254-445T	YES	213-445T	YES	YES	YES	YES
10	5.06-194.6	277	16,000	254-445T	YES	254-445T	YES	YES	YES	YES
11	5.06-194.6	375	19,400	284-445T	YES	284-445T	YES	YES	YES	YES
12	5.06-194.6	493	17,500	284-445T	YES	284-445T	YES	YES	YES	YES

* Based on competitive ratings and the DODGE unit it replaces.

** Overhung Load.

■ Sizes 1-3 Discontinued. Remaining Stock May Be Available

FEATURES

- Maximum Input Horsepower @1750 RPM - 1600 HP
- Maximum Output Torque- 502,000 In-lbs
- Balanced Metric Design
- All Heavy Duty Tapered Roller Bearings
- Standard Double-lip Seals With Standard Viton Option
- Up To 250 HP Scoop Packages With Multiple Coupling Options
- Custom Mechanical Power Transmission Packages
- AC/DC Variable Speed Application Expertise
- Warranty Protection Plan - 36/12 Months
- Quick Response Delivery Program
- ISO 9002 Certified



MAXUM Concentric Reducer

MAXUM SPEED REDUCER

The speed reducer shall be a direct coupled, V-belt, or chain driven enclosed concentric type unit with a double or triple reduction ratio. The published rating of the speed reducer shall conform to all applicable AGMA standards.

The reducer housing shall be constructed of corrosion resistant, Class 30 gray iron with cast internal walls for added strength. All housings and end covers shall be doweled and precision machined to assure accurate alignment for all gear sets.

All gearing shall be of single helical design, and crown shaved or ground to provide an ellipsoid tooth form to eliminate tooth end bearing and assure meshing in the strongest tooth area. All gears shall be case carburized to insure a high surface durability and resilient tooth core for greater impact resistance and longer service life. Pinions shall be supported between bearings to maintain proper alignment of the gear meshes, to minimize deflections and to maximize load carrying capabilities.

Reducer bearings shall be the taper roller type, and provide a minimum 25,000 hour average life. All seals shall be of the double lip, spring loaded type, made of nitrile rubber.

Reducer gears and bearings shall be splash lubricated using a quality petroleum base oil containing rust and oxidation inhibitors.

MAXUM SPEED REDUCER WITH SCOOP

The speed reducer shall be direct coupled enclosed concentric type unit with a double or triple reduction ratio.

The published rating of the speed reducer shall conform to all applicable AGMA standards. The motor shall be supported by a steel fabricated scoop of rigid design to maintain motor shaft alignment to the input shaft of the speed reducer.

The reducer housing shall be constructed of corrosion resistant, Class 30 gray iron with cast internal walls for added strength. All housings and end covers shall be doweled and precision machined to assure accurate alignment for all gear sets.

All gearing shall be of single helical design, and crown shaved or ground to provide an ellipsoid tooth form to eliminate tooth end bearing and assure meshing in the strongest tooth area. All gears shall be case carburized to insure a high surface durability and resilient tooth core for greater impact resistance and longer service life. Pinions shall be supported between bearings to maintain proper alignment of the gear meshes, to minimize deflections and to maximize load carrying capabilities.

Reducer bearings shall be the taper roller type, and provide a minimum 25,000 hour average life. All seals shall be of the double lip, spring loaded type, made of nitrile rubber.

Reducer gears and bearings shall be splash lubricated using a quality petroleum base oil containing rust and oxidation inhibitors.

The fabricated steel scoop shall be supported by the reducer housing and shall include a means of accommodating the motor frame required.

A flexible coupling of either the elastomeric or grid type design shall be furnished to couple motor to reducer. The couplings shall be furnished with Taper-Lock bushings, or bored-to-size, for attachment of coupling flange to shafts. The shaft coupling shall be covered by an approved guard as required.

MAXUM SPEED REDUCER WITH BASE PLATES

The speed reducer shall be direct coupled enclosed concentric type unit with a double or triple reduction ratio. The published rating of the speed reducer shall conform to all applicable AGMA standards. The motor shall be supported by a steel fabricated baseplate of rigid design to maintain motor shaft alignment to the input shaft of the speed reducer.

The reducer housing shall be constructed of corrosion resistant, Class 30 gray iron with cast internal walls for added strength. All housing and end covers shall be doweled and precision machined to assure accurate alignment for all gear sets.

All gearing shall be of single helical design, and crown shaved or ground to provide an ellipsoid tooth form to eliminate tooth end bearing and assure meshing in the strongest tooth area. All gears shall be case carburized to insure a high surface durability and resilient tooth core for greater impact resistance and longer service life. Pinions shall be supported between bearings, to maintain proper alignment of the gear meshes, to minimize deflections and to maximize load carrying capabilities.

Reducer bearings shall be the taper roller type, and provide a minimum 25,000 hour average life. All seals shall be of the double lip, spring loaded type, made of nitrile rubber.

Reducer gears and bearings shall be splash lubricated using a quality petroleum base oil containing rust and oxidation inhibitors.

The steel baseplate shall be of Heavy Duty design, precision machined and stress relieved, and shall include a means of accommodating the motor frame required and providing the proper alignment with reducer shaft.

A flexible coupling of either the elastomeric or grid type design shall be furnished to couple the motor to the reducer. The couplings shall be furnished with Taper-Lock bushings, or bored-to-size, for attachment of coupling hub to the shafts. The shaft coupling shall be covered by an approved guard as required.

HOW TO ORDER NOMENCLATURE



MAXUM Concentric Reducer

HOW TO ORDER MAXUM REDUCERS

Once the correct DODGE MAXUM Concentric Shaft Reducer and accessories have been selected from information published in this catalog, the complete assembly can be specified or ordered using the nomenclature provided and/or the part numbers listed in the specification section, pages G3-23 through G3-33.

NOTE: If selection cannot be made from information herein, technical assistance is available to recommend drives for new or existing applications. Submit full details to DODGE MAXUM Application Engineering (864) 288-9050; DODGE Customer Service (864) 297-4800.

NOMENCLATURE

XXXX - XXXX - XX - XXX.XX - XX

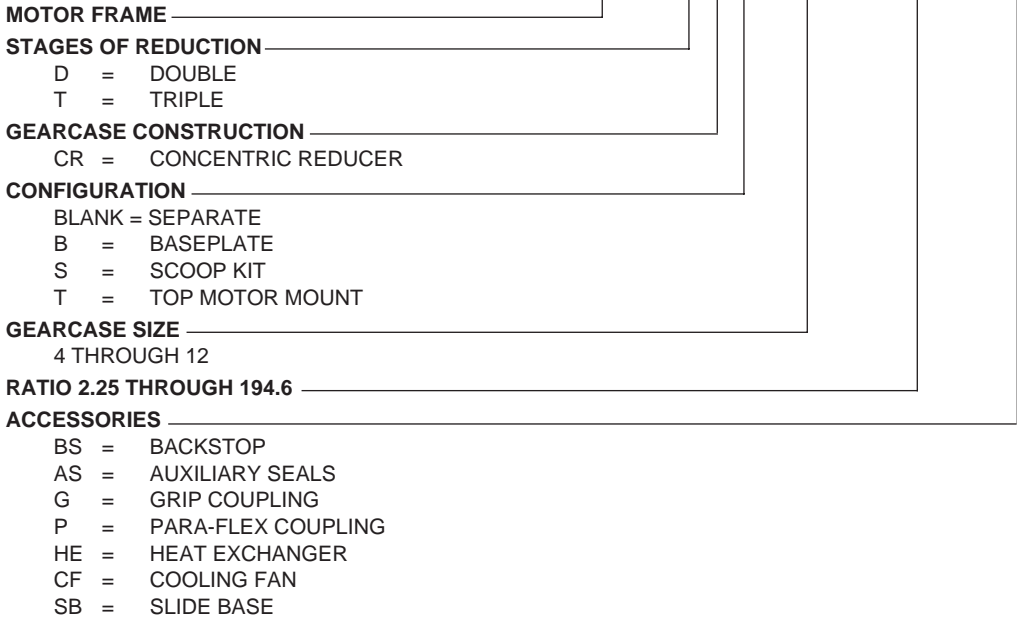

NOMENCLATURE EXAMPLES

SEPARATE REDUCER

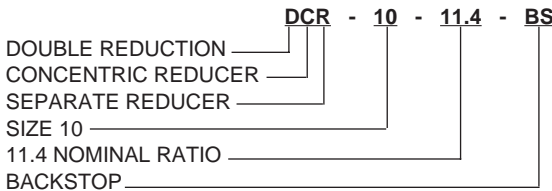

REDUCER WITH SCOOP

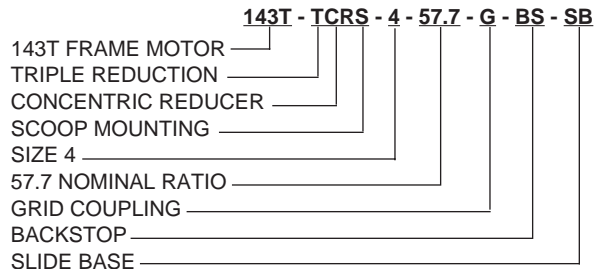

FEATURES/BENEFITS PAGE G3-3	EASY SELECTION PAGE G3-7	SELECTION/DIMENSIONS PAGE G3-23	RELATED PRODUCTS PAGE G3-55
--------------------------------	-----------------------------	------------------------------------	--------------------------------



MAXUM Concentric Reducer EASY SELECTION METHOD - SEPARATE REDUCERS (for 1750 RPM motors)

When to Use Easy Selection

The Easy Selection tables for Separate Reducers are for electric motor selections up to 250 HP with input speeds of 1750 rpm using AGMA recommended service factors. For all other motor/prime mover input speeds and horse powers, use the Horsepower/Torque Selection Method on pages G3-57 through G3-58.

NOTE: If your application has unusual requirements (i.e., excessive shock or overloads, extreme ambient temperatures, non-standard motors or oversized equipment), refer to Horsepower/ Torque Selection Method.

How to Select

Step 1: Determine Service Factor – See Table 2 to determine service factor for applications under normal conditions. **Note:** When service factor exceeds 2.0, Horsepower/ Torque Selection Method must be used.

NOTE: AGMA classifies scoop mounted motors as gear motor applications which are sized using a load classification in place of a service factor. (See Easy Selection Method for scoop mounting, page G3-16.)

Step 2: Determine Unit Size – See tables on pages G3-11 through G3-15. Find the service factor table that is required for the application. Read the unit size under required Horsepower and opposite the required low speed shaft RPM. **Note:** For applications where fan cooling is unacceptable, use easy selection table with an increased service factor.

Step 3: Check External Thrust and Overhung Load – See information on page G3-59 to calculate high speed and low speed overhung loads. Consult DODGE about external thrust loads.

Step 4: Check Dimensions – See specification/dimension section, pages G3-23 through G3-33 for dimensions, weights and part numbers.

Step 5: Select Accessories – Check matrix for compatibility of combinations of accessories, page G3-34.

Example: Easy Selection Method - Separate Reducers

A 75 hp 1750 rpm motor is used to drive a uniformly loaded belt conveyor at 84 rpm operating 16 hours per day. The reducer is coupling connected at both the input and output shafts.

Step 1: Determine Service Factor - From Table 2, Service Factors, locate "Belt Conveyors - Uniformly Loaded or Fed." Select the Service Factor of 1.25 under the column headed 10+ hours/day service.

Step 2: Determine Unit Size - Turn to the Easy Selection Table for 1.25 Service Factor (Table 4). Find the column headed by 75 motor horsepower and read down to 83.6

rpm. A MAXUM size 7 is the correct selection and the nominal ratio is 20.93:1.

Step 3: Check External Thrust and Overhung Loads - Since the input and output shafts are coupling connected, thrust and overhung loads will not exist. (An overhung load example is given on page G3-59. Consult DODGE about external thrust loads.)

Step 4: Check Dimensions - Refer to the specifications for the DODGE MAXUM size 7 reducer located on page G3-29. The part number for the reducer is **299145**.

Step 5: Select Accessories - No accessories were required for this example.

FEATURES/BENEFITS PAGE G3-3	NOMENCLATURE PAGE G3-6	SELECTION/DIMENSIONS PAGE G3-23	RELATED PRODUCTS PAGE G3-55
--------------------------------	---------------------------	------------------------------------	--------------------------------

EASY SELECTION



MAXUM Concentric Reducer

SERVICE FACTORS

The service factors that follow are adapted from AGMA 6010-E88 Appendix A.

Applications which expose the gear drive to high starting torques, extreme repetitive shock, or where high energy loads must be absorbed as when stalling, require special consideration. Service factors for these special applications should be agreed upon by the user and DODGE since variations of the values in the table may be required.

The service factors in the service factor table are based on the use of an electric or hydraulic motor or the use of a steam or gas turbine as a prime mover. If the prime mover is a single or multi-cylinder engine, then the service factor must be adjusted in accordance with Table 1.

Table 1: Conversion Table For Single Or Multi-cylinder Engines To Find Equivalent Single Or Multi-Cylinder Application Factor Or Service Factor

Steam and Gas Turbines, Hydraulic or Electric Motor	Single Cylinder Engines	Multi Cylinder Engines
1.00	1.50	1.25
1.25	1.75	1.50
1.50	2.00	1.75
1.75	2.25	2.00
2.00	2.50	2.25
2.25	2.75	2.50
2.50	3.00	2.75
2.75	3.25	3.00
3.00	3.50	3.25
3.50	4.00	3.75

Table 2: Service Factors

Application	Service		Application	Service		Application	Service	
	3-10 Hrs./Day	10+ Hrs./Day		3-10 Hrs./Day	10+ Hrs./Day		3-10 Hrs./Day	10+ Hrs./Day
AGITATORS			Scale Hoppers -			Reciprocating:		
Pure Liquids	1.00	1.25	Frequent Starts	1.25	1.50	Multi-cylinder	1.50	1.75
Liquids & Solids	1.25	1.50	BRICK PRESS (Clay Working)	1.75	2.00	Single Cylinder	1.75	2.00
Liquids - Variable Density	1.25	1.50	BRIQUETTE MACHINES (Clay Working)	1.75	2.00	CONCRETE MIXERS		
APRON CONVEYORS			BUCKET			Continuous	1.25	1.50
Uniformly Loaded			Conveyors Uniform	1.00	1.25	Intermittent	1.25	1.50
or Fed			Conveyors Heavy Duty	1.25	1.50	CONVEYORS - Uniformly		
Heavy Duty	1.00	1.25	Elevators Cont.	1.00	1.25	Loaded or Fed: Apron		
APRON FEEDERS	1.25	1.50	Elevators Uniform	1.00	1.25	Assembly, Belt,		
ASSEMBLY CONVEYORS			Elevators Heavy Duty	1.25	1.50	Bucket, chain, Flight		
Uniformly Loaded			CALENDERS			Oven, Screw	1.00	1.25
or Fed			Rubber		1.50	CONVEYORS - Heavy Duty		
Heavy Duty	1.00	1.25	Textile	1.25	1.50	Not Uniformly Fed:		
APRON FEEDERS	1.25	1.50	CANE KNIVES		1.50	Apron, Assembly, Belt,		
ASSEMBLY CONVEYORS			CAN FILLING MACHINES	1.00	1.25	Bucket, Chain, Flight,		
Uniformly Loaded			CARD MACHINES (Textile)	1.25	1.50	Oven, Screw	1.25	1.50
or Fed			CAR DUMPERS	1.75	2.00	CONVEYORS - Severe Duty		
Heavy Duty	1.00	1.25	CAR PULLERS	1.25	1.50	Live Roll Reciprocating	†	†
BALL MILLS	▲	▲	CEMENT KILNS	▲	▲	Shaker	1.75	2.00
BARGE HAUL PULLERS	1.25	1.50	CENTRIFUGAL			COOKERS (Brewing &		
BARKING			Blowers, compressors,			Distilling), (Food)	1.25	1.25
Drums (coupling connected)		2.00	Discharge Elevators,			COOLING TOWER FANS	†	†
Mechanical		2.00	Fans or Pumps	1.00	1.25	CRANES	†	†
BAR SCREENS (Sewage)	1.25	1.25	CHAIN CONVEYORS			CRUSHERS		
BATCHERS (Textile)	1.25	1.50	Uniformly Loaded or Fed	1.00	1.25	Ore or Stone	1.75	2.00
BELT CONVEYORS			Heavy Duty	1.25	1.50	Sugar		1.50
Uniformly Loaded			CHEMICAL FEEDERS			DEWATERING SCREENS		
or Fed			(Sewage)	1.25	1.25	(Sewage)	1.50	1.50
Heavy Duty	1.00	1.25	CLARIFIERS	1.00	1.25	DISC FEEDERS	1.00	1.25
BELT FEEDERS	1.25	1.50	CLASSIFIERS	1.25	1.50	DISTILLING (See Brewing)		
BENDING ROLLS			CLAY WORKING IND.			DOUBLE ACTING PUMPS		
(Machine)	1.25	1.50	Brick Press	1.75	2.00	2 or More Cylinders	1.25	1.50
BLOWERS			Briquette Machines	1.75	2.00	Single Cylinder	1.25	1.50
Centrifugal	1.00	1.25	Pug Mills	1.25	1.50	DOUGH MIXER (Food)	†	†
Lobe	1.25	1.50	COLLECTORS (Sewage)	1.25	1.25	DRAW BENCH (Metal		
Vane	1.25	1.50	COMPRESSORS			Mills) carriage & Main		
BOTTLING MACHINERY	1.00	1.25	Centrifugal	1.00	1.25	Drive	1.25	1.50
BREWING & DISTILLING			Lobe	1.25	1.50	DREDGES		
Bottling Machinery	1.00	1.25				Cable Reels, Conveyors	1.25	1.50
Brew Kettles, Cont. Duty	1.25	1.25				Cutter Head & Jig Drives	2.00	2.00
Can Filling Machines	1.00	1.25						
Cookers - Cont. Duty	1.25	1.25						
Mash Tubs - Cont. Duty	1.25	1.25						

FEATURES/BENEFITS PAGE G3-3	NOMENCLATURE PAGE G3-6	SELECTION/DIMENSIONS PAGE G3-23	RELATED PRODUCTS PAGE G3-55
--------------------------------	---------------------------	------------------------------------	--------------------------------



MAXUM Concentric Reducer

Table 2 - Service Factor (cont'd)

Application	Service		Application	Service		Application	Service	
	3-10 Hrs./Day	10+Hrs./Day		3-10 Hrs./Day	10+ Hrs./Day		3-10 Hrs./Day	10+ Hrs./Day
Maneuvering Winches	1.25	1.50	COMPRESSORS	1.25	1.50	with Helical Ring Gear		1.50
Pumps	2.00	2.00	LOG HAULS (Lumber)			Direct connected		2.00
Screen Drives	1.75	2.00	Incline-well Type	1.75	1.75	Cement Kilns, Dryers,		
Stackers, Utility Winches	1.25	1.50	LOOMS (Textile)	1.25	1.50	Coolers, Pebble, Plain		
DRY DOCK CRANES	†	†	LUMBER INDUSTRY			& Wedge Bar Mills		1.50
DRYERS & COOLERS			Barkers - Spindle Feed	1.25	1.50	Tumbling Barrels	1.75	2.00
(Mills, Rotary)		1.50	Barkers - Main Drive	1.75	1.75	MIXERS (Also see Agitators)		
DYEING MACHINERY			Carriage Drive	†	†	Concrete, Cont. & Int.	1.25	1.50
(Textile)	1.25	1.50	Conveyors			Constant Density	1.00	1.25
ELEVATORS			Burner	1.25	1.50	Variable Density	1.25	1.50
Bucket - Uniform Load	1.00	1.25	Main or Heavy Duty	1.50	1.50	NAPPERS (Textile)	1.25	1.50
Bucket - Heavy Duty	1.25	1.50	Main Log	1.75	2.00	OIL INDUSTRY		
Centrifugal Discharge	1.00	1.25	Re-Saw Merry-Go-			Chillers	1.25	1.50
Escalators	1.00	1.25	Round	1.25	1.50	Oil Well Pumping	†	†
Freight	1.25	1.50	Slab	1.75	2.00	Paraffin Filter Press	1.25	1.50
Gravity Discharge	1.00	1.25	Transfer	1.25	1.50	Rotary Kilns	1.25	1.50
Man. Lifts, Passenger	†	†	Chains - Floor	1.50	1.50	ORE CRUSHERS	1.75	2.00
EXTRUDERS			Chains - Green	1.50	1.75	OVEN CONVEYORS		
General	1.50	1.50	Cut-Off Saws - Chain			Uniform	1.00	1.25
Plastics			& Drag	1.50	1.75	Heavy Duty	1.25	1.50
Variable Speed Drive	1.50	1.50	Debarking Drums	1.75	2.00	PAPER MILLS (1)		
Fixed Speed Drive	1.75	1.75	Feeds - Edger	1.25	1.50	Agitator (Mixer)		1.50
Rubber			Feeds - Gang	1.75	1.75	Agitator for Pure Liquids		1.25
Continuous Screw			Feeds - Trimmer	1.25	1.50	Barking Drums. Barkers		
Operation	1.75	1.75	Log Deck	1.75	1.75	-Mech.		2.00
Intermittent Screw			Log Hauls - Incline,			Beater		1.50
Operation	1.75	1.75	Well Type	1.75	1.75	Breaker Stack		1.25
FANS			Log Turning Devices	1.75	1.75	Calendar (2)		1.25
Centrifugal	1.00	1.25	Planer Feed	1.25	1.50	Chipper		2.00
Cooling Towers	†	†	Planer Tilting Hoists	1.25	1.50	Chip Feeder		1.50
Forced Draft	1.25	1.25	Rolls - Live - Off			Coating Rolls		1.25
Induced Draft	1.50	1.50	Bearing - Roll cases	1.75	1.75	Conveyors -		
Large (Mine, etc.)	1.50	1.50	Sorting Table, Tipple			Chip, Bark, Chemical		1.25
Large Industrial	1.50	1.50	Hoist	1.25	1.50	Log (Incl. Slab)		2.00
Light (Small Diameter)	1.00	1.25	Transfer - Chain &			Couch Rolls		1.25
FEEDERS			Craneway	1.50	1.75	Cutter		2.00
Apron, Belt	1.25	1.50	Tray Drives	1.25	1.50	Cylinder Molds		1.25
Disc	1.00	1.25	Veneer Lathe Drives	†	†	Dryers (2)		
Reciprocating	1.75	2.00	MACHINE TOOLS			Paper Mach. &		
Screw	1.25	1.50	Auxiliary Drives	1.00	1.25	Conveyor Type		1.25
FLIGHT			Banding Rolls	1.25	1.50	Embosses		1.25
Conveyors, Uniform	1.00	1.25	Main Drives	1.25	1.50	Extruder		1.50
Conveyors, Heavy	1.25	1.50	Notching Press (Belted)	†	†	Fourdrinier Rolls -		
FOOD/INDUSTRY			Plate Planers	1.75	2.00	Lumpbreaker, Wire		
Beet Slicers	1.25	1.50	Punch Press (Geared)	1.75	2.00	Turning, Dandy &		
Bottling, Can Filling			Tapping Machines	1.75	2.00	Return Rolls		1.25
Machine	1.00	1.25	MANGLE (Textile)	1.25	1.50	Jordan		1.50
Cereal Cookers	1.00	1.25	MASH TUBS (Brewing &			Kiln Drive		1.50
Dough Mixers, Meat			Distilling	1.25	1.25	Mt. Hope & Paper Rolls		1.25
Grinders	1.25	1.50	MEAT GRINDERS (Food)	1.25	1.50	Platter		1.50
GENERATORS (Not			METAL MILLS			Presses (Felt & Suction)		1.25
Welding)	1.00	1.25	Draw Bench Carriages			Pulper		2.00
GRAVITY DISCHARGE			& Main Drives	1.25	1.50	Reel (Surface Type)		1.25
ELEVATORS	1.00	1.25	Pinch, Dryer & Scrubber			Screens -		
HAMMER MILLS	1.75	2.00	Rolls Reversing	†	†	Chip, Rotary		1.50
HOISTS (See Cranes)	†	†	Slitters	1.25	1.50	Vibrating		2.00
INDUCED DRAFT FANS	1.50	1.50	Table Conveyors,			Size Press		1.25
KILNS	▲	▲	Non-Reversing			Super Calendar (3)		1.25
LAUNDRY			Group Drives	1.50	1.50	Thickener & Washer -		
Tumblers	1.25	1.50	Individual Drives	2.00	2.00	AC Motor		1.50
Washers	1.50	2.00	Reversing	†	†	DC Motor		1.25
LINE SHAFTS			Wire Drawing &			Vacuum Pumps		1.50
Driving Processing			Flattening Machines			Wind & Unwind Stand		1.25
Equipment	1.25	1.50	Wire Winding Machines	1.50	1.50	Winders (Surface Type)		1.25
Other Line Shafts, Light	1.00	1.25	MILLS, ROTARY			Yankee Dryer (2)		1.25
LIVE ROLL CONVEYORS	†	†	Ball and Rod Mills			PASSENGER ELEVATORS	†	†
LOBE BLOWERS OR			with Spur Ring Gear		2.00	PEBBLE MILLS	▲	▲

FEATURES/BENEFITS PAGE G3-3	NOMENCLATURE PAGE G3-6	SELECTION/DIMENSIONS PAGE G3-23	RELATED PRODUCTS PAGE G3-55
--------------------------------	---------------------------	------------------------------------	--------------------------------

EASY SELECTION



MAXUM Concentric Reducer

Table 2 - Service Factor (cont'd)

Application	Service		Application	Service		Application	Service	
	3-10 Hrs./Day	10+Hrs./Day		3-10 Hrs./Day	10+Hrs./Day		3-10 Hrs./Day	10+Hrs./Day
PLASTICS INDUSTRY			Mixing Mill-2smooth rolls (If corrugated rolls are used, then use the same service factors that are used for a Cracker-Warmer)	1.50	1.50	SLITTERS (metal)	1.25	1.50
Primary Processing			Batch Drop Mill	1.50	1.50	SLUDGE COLLECTORS (Sewage)	1.25	1.25
Intensive Internal Mixers			2 Smooth Rolls	1.50	1.50	SOAPERS (Textile)	1.25	1.50
Batch Mixers	1.75	1.75	Cracker Warmer-2	1.75	1.75	SPINNERS (Textile)	1.25	1.50
Continuous Mixers	1.50	1.50	Rolls: 1 corrugated Roll	1.75	1.75	STEERING GEARS		
Batch Drop Mill - 2 Smooth Rolls	1.25	1.25	Cracker-2 corrugated Rolls	2.00	2.00	STOKERS	1.00	1.25
Continuous Feed, Holding & Blend Mill	1.25	1.25	Holding, Feed & Blend Mill-2 Rolls	1.25	1.25	STONE CRUSHERS	1.75	2.00
Compounding Mill	1.25	1.25	Refiner-2 Rolls	1.50	1.50	SUGAR INDUSTRY		
Calenders	1.50	1.50	Calenders	1.50	1.50	Cane Knives, Crushers Mill		1.50
Secondary Processing			SAND MULLERS	1.25	1.50	TABLE CONVEYORS (Non-Reversing)		
Blow Molders	1.50	1.50	SCREENS			Group Drives	1.50	1.50
Coating	1.25	1.25	Air Washing	1.00	1.25	Individual Drives	2.00	2.00
Film	1.25	1.25	Rotary-Sand or Gravel	1.25	1.50	Reversing	†	†
Pipe	1.25	1.25	Traveling Water Intake	1.00	1.25	TENTER FRAMES (Textile)	1.25	1.50
Pre-Plasticizers	1.50	1.50	SCREW CONVEYORS			TEXTILE INDUSTRY		
Rods	1.25	1.25	Uniform	1.00	1.25	Batchers, calenders	1.25	1.50
Sheets	1.25	1.25	Heavy Duty or Feeder	1.25	1.50	Card Machines	1.25	1.50
Tubing	1.25	1.25	SCUM BREAKERS (Sewage)	1.50	1.50	Dry Cans, Dryers	1.25	1.50
PLATE PLANERS	1.75	2.00	SEWAGE DISPOSAL			Dyeing Machinery	1.25	1.50
PRINTING PRESSES	†	†	Bar Screens	1.25	1.25	Knitting Machinery	†	†
PROPORTIONING PUMPS	1.25	1.50	Chemical Feeders	1.25	1.25	Looms, Mangles		
PUG MILLS (Clay)	1.25	1.50	Collectors	1.25	1.25	Nappers, Pads	1.25	1.50
PULLERS (Barge Haul)	1.25	1.50	Dewatering Screens	1.50	1.50	Range Drives	†	†
PUMPS			Scum Breakers	1.50	1.50	Slashers, Soapers		
Centrifugal	1.00	1.25	Slow or Rapid Mixers	1.50	1.50	Spinners	1.25	1.50
Proportioning	1.25	1.50	Thickeners	1.50	1.50	Tenter Framers,		
Reciprocating			Vacuum Filters	1.50	1.50	Washers, Winders	1.25	1.50
Single Act., 3 or More Cyl.	1.25	1.50	SHAKER CONVEYORS	1.75	2.00	THICKNESS (Sewage)	1.50	1.50
Double Act, 2 or More Cyl.	1.25	1.50	SHEETERS (Rubber)	1.50	1.50	TUMBLING BARRELS	1.75	2.00
Single Act., 1 or 2 Cyl.	†	†	SINGLE ACTING PUMP			VACUUM FILTERS (Sewage)	1.50	1.50
Double Act, 1 Cyl.	†	†	1 or 2 Cylinders	†	†	VANE BLOWERS	1.25	1.50
Rotary: Gear, Lobe, Vane	1.00	1.25	3 or More Cylinders	1.25	1.50	WINCHES (Dredges)	1.25	1.50
PUNCH PRESS (Gear Driven)	1.75	2.00	SKIP HOIST	†	†	WINDERS (Textile)	1.25	1.50
RECIPROCATING			SLAB PUSHERS	1.50	1.50	WINDGLASS	†	†
Conveyors, Feeders	1.75	2.00				WIRE		
RECIPROCATING COMPRESSORS						Drawing Machines	1.25	1.50
Multi Cylinder	1.50	1.75				Winding Machines	1.50	1.50
Single Cylinder	1.75	2.00						
REVERSING DIRECTION APPLICATION	†	†	▲ Consult DODGE					
ROD MILLS	▲	▲	▲ See Mill, Rotary					
ROTARY			(1) Service factors for paper mill applications are applied to the nameplate rating of the electric motor at the motor rated base speed					
Pumps	1.00	1.25	(2) Using anti-friction bearings only. Use 1.50 for sleeve bearings					
Screens (Sand and Gravel)	1.25	1.50	(3) When a super calender operates over a speed range of part constant horsepower and part constant torque and the constant horsepower speed range is greater than 1.5:1, use a service factor of 1.00 at base speed. When operating at constant torque over the entire speed range or when the constant horsepower speed range is less than 1.5:1, a 1.25 service factor should be used.					
RUBBER INDUSTRY			NOTE: when mounting variable speed AC or DC motors, consult pages G3-81 and G3-82.					
Intensive Internal Mixers								
Batch Mixers	1.75	1.75						
Continuous Mixers	1.50	1.50						

FEATURES/BENEFITS PAGE G3-3	NOMENCLATURE PAGE G3-6	SELECTION/DIMENSIONS PAGE G3-23	RELATED PRODUCTS PAGE G3-55
--------------------------------	---------------------------	------------------------------------	--------------------------------



MAXUM Concentric Reduce

Table 3: Easy Selection - Separate Reducers 1750 RPM - 1.0 Service Factor

Norm Ratio	Approx Low Speed Shaft RPM	Unit Red.	MAXUM Reducer Size Used with Motor Horsepower of: (With Frame Size References)										
			1	1-1/2	2	3	5	7-1/2	10	15	20	25	
			(143T)	(145T)	(145T)	(182T)	(184T)	(213T)	(215T)	(254T)	(256T)	(284T)	
2.25	777.8	DOUBLE	1	1	1	1	1	1	1	1	1	1	
2.75	636.4		1	1	1	1	1	1	1	1	1	1	
3.37	519.3		1	1	1	1	1	1	1	1	1	1	
4.13	423.7		1	1	1	1	1	1	1	1	1	1	
5.06	345.8		1	1	1	1	1	1	1	1	1	1	
6.20	282.3		1	1	1	1	1	1	1	1	1	1	
7.59	230.6		1	1	1	1	1	1	1	1	1	2	
9.30	188.2		1	1	1	1	1	1	1	1	2	2	
11.39	153.6		1	1	1	1	1	1	1	1	2	2	
13.95	125.4		1	1	1	1	1	1	1	2	2	3	
17.09	102.4		1	1	1	1	1	1	1	2	3	3	
20.93	83.6		1	1	1	1	1	1	2	2	3	3	
25.63	68.3		1	1	1	1	1	1	2	3	3	4	
31.39	55.8		TRIPLE	1	1	1	1	1	2	2	3	4	4
38.44	45.5	1		1	1	1	1	2	3	3	4	4	
47.08	37.2	1		1	1	1	2	2	3	4	4	5	
57.67	30.4	1		1	1	1	2	3	3	4	5	6	
70.62	24.8	1		1	1	1	2	3	4	5	6	6	
86.50	20.2	1		1	1	2	3	4	4	6	6	6	
105.90	16.5	1		1	1	2	3	4	5	6	6	7	
129.70	13.5	1		1	2	2	4	4	6	6	7	7	
158.90	11.0	1		2	2	3	4	5	6	7	7	9	
194.60	9.0	1		2	2	3	4	6	6	7	9	9	
Norm Ratio	Approx Low Speed Shaft RPM	Unit Red.	MAXUM Reducer Size Used with Motor Horsepower of: (With Frame Size References)										
			30	40	50	60	75	100	125	150	200	250	
			(286T)	(324T)	(326T)	(364T)	(365T)	(405T)	(444T)	(445T)	(447T)	(449T)	
2.25	777.8	DOUBLE	1	2	3	3 ●	3 ●	4 ●	4 ●	5 ●	-	-	
2.75	636.4		1	2	3	3 ●	3 ●	4 ●	5 ●	5 ●	6 ●	-	-
3.37	519.3		2	2	3	3	4 ●	4 ●	5 ●	6 ●	-	-	
4.13	423.7		1	3	3 ●	3 ●	4 ●	4 ●	5 ●	6 ●	-	-	
5.06	345.8		2	3	3 ●	3 ●	4 ●	4 ●	5 ●	6 ●	7 ●	7 ●	
6.20	282.3		2	3	3 ●	4 ●	4 ●	5 ●	5 ●	6 ●	7 ●	7 ●	
7.59	230.6		2	3	3 ●	4 ●	4 ●	5 ●	5 ●	6 ●	7 ●	7 ●	
9.30	188.2		3	3	4	4 ●	4 ●	5 ●	6 ●	7 ●	7 ●	7 ●	
11.39	153.6		3	3 ●	4 ●	4 ●	5 ●	6 ●	7	7 ●	7 ●	9 ●	
13.95	125.4		3	4	4 ●	5 ●	5 ●	6 ●	7	7 ●	9 ●	9 ●	
17.09	102.4		3	4	4 ●	5 ●	6 ●	7	7 ●	7 ●	9 ●	10 ●	
20.93	83.6		4	4 ●	5 ●	6 ●	6 ●	7	7 ●	9 ●	9 ●	10 ●	
25.63	68.3		4	5 ●	6	6 ●	7	7	9 ●	9 ●	10 ●	10 ●	
31.39	55.8		TRIPLE	4	6	6	7	7	9	9	10 ●	11 ●	
38.44	45.5	5		6	6	7	7	9	9 ●	10 ●	10 ●	11 ●	
47.08	37.2	6		6	7	7	9	9	10 ●	10 ●	11 ●	12 ●	
57.67	30.4	6		7	7	9	9	10 ●	10 ●	11 ●	12 ●	-	
70.62	24.8	6		7	9	9	9	10 ●	11 ●	11 ●	-	-	
86.50	20.2	7		9	9	9	10	10	11	12	-	-	
105.90	16.5	7		9	9	10	10	11	12	-	-	-	
129.70	13.5	9		9	10	10	11	12	-	-	-	-	
158.90	11.0	9		10	10	11	11	-	-	-	-	-	
194.60	9.0	9		10	11	11	12	-	-	-	-	-	

● Cooling Fan Required

+ TEFC-XE Frame, Energy Efficient Motors

■ Sizes 1-3 discontinued. Remaining stock may be available

FEATURES/BENEFITS PAGE G3-3	NOMENCLATURE PAGE G3-6	SELECTION/DIMENSIONS PAGE G3-23	RELATED PRODUCTS PAGE G3-55
--------------------------------	---------------------------	------------------------------------	--------------------------------

EASY SELECTION



MAXUM Concentric Reducer

Table 4: Easy Selection - Separate Reducers 1750 RPM - 1.25 Service Factor

Norm Ratio	Approx Low Speed Shaft RPM	Unit Red.	MAXUM Reducer Size Used with Motor Horsepower of: (With Frame Size References)										
			1	1-1/2	2	3	5	7-1/2	10	15	20	25	
			(143T)	(145T)	(145T)	(182T)	(184T)	(213T)	(215T)	(254T)	(256T)	(284T)	
2.25	777.8	DOUBLE	1	1	1	1	1	1	1	1	1	1	
2.75	636.4		1	1	1	1	1	1	1	1	1	2	
3.37	519.3		1	1	1	1	1	1	1	1	1	2	
4.13	423.7		1	1	1	1	1	1	1	1	1	1	
5.06	345.8		1	1	1	1	1	1	1	1	1	2	
6.20	282.3		1	1	1	1	1	1	1	1	1	2	
7.59	230.6		1	1	1	1	1	1	1	1	2	2	
9.30	188.2		1	1	1	1	1	1	1	1	2	2	
11.39	153.6		1	1	1	1	1	1	1	2	2	3	
13.95	125.4		1	1	1	1	1	1	1	2	3	3	
17.09	102.4		1	1	1	1	1	1	2	2	3	4	
20.93	83.6		1	1	1	1	1	2	2	3	3	4	
25.63	68.3	1	1	1	1	1	2	2	3	4	4		
31.39	55.8	TRIPLE	1	1	1	1	1	2	3	4	4	5	
38.44	45.5		1	1	1	1	2	2	3	4	4	6	
47.08	37.2		1	1	1	1	2	3	3	4	5	6	
57.67	30.4		1	1	1	1	2	2	3	4	5	6	
70.62	24.8		1	1	1	2	3	4	4	6	6	7	
86.50	20.2		1	1	1	2	3	4	5	6	6	7	
105.9	16.5		1	1	2	3	4	4	6	6	7	7	
129.7	13.5		1	2	2	3	4	5	6	7	7	9	
158.9	11.0		1	2	3	3	4	6	6	7	9	9	
194.6	9.0		2	2	3	4	5	6	7	9	9	10	
Norm Ratio	Approx Low Speed Shaft RPM		Unit Red.	MAXUM Reducer Size Used with Motor Horsepower of: (With Frame Size References)									
				30	40	50	60	75	100	125	150	200	250
		(286T)		(324T)	(326T)	(364T)	(365T)	(405T)	(444T)	(445T)	(447T)	(449T)	
2.25	777.8	DOUBLE	2	2	3	3●	4●	4●	5●	6●	-	-	
2.75	636.4		2	3	3	3●	4●	5●	5●	6●	-	-	
3.37	519.3		2	3	3	4	4●	5●	6●	6●	-	-	
4.13	423.7		2	3	3●	4●	4●	5●	5●	6●	-	-	
5.06	345.8		2	3	3●	4●	4●	5●	5●	6●	7●	7●	
6.20	282.3		2	3	4	4●	4●	5●	6●	7	7●	7●	
7.59	230.6		2	3	4	4●	5●	5●	7	7	7●	7●	
9.30	188.2		3	4	4	4●	5●	6●	7	7	7●	9●	
11.39	153.6		3	4	4●	5●	5●	7	7	7●	9●	9●	
13.95	125.4		4	4	5	5●	6●	7	7	7●	9●	10●	
17.09	102.4		4	4	5●	6	7	7	9	9●	10●	10●	
20.93	83.6		4	5	6	6●	7	7	9●	9●	10●	10●	
25.63	68.3	5	6	6	7	7	9●	9	9●	10●	11●		
31.39	55.8	TRIPLE	6	6	7	7	9	9	9	10●	11●	12●	
38.44	45.5		6	6	7	7	9	9	10●	10●	11●	12●	
47.08	37.2		6	7	7	9	9	10●	10●	11●	12●	-	
57.67	30.4		7	7	9	9	9	10●	11	11●	-	-	
70.62	24.8		7	9	9	9	10	11	11●	12●	-	-	
86.50	20.2		7	9	9	10	10	11	12	-	-	-	
105.9	16.5		9	9	10	10	11	12	-	-	-	-	
129.7	13.5		9	10	10	11	12	-	-	-	-	-	
158.9	11.0		10	10	11	11	-	-	-	-	-	-	
194.6	9.0		10	11	11	12	-	-	-	-	-	-	

! Cooling Fan Required

+ TEFC-XE Frame, Energy Efficient Motors

Sizes 1-3 discontinued. Remaining stock may be available

FEATURES/BENEFITS PAGE G3-3	NOMENCLATURE PAGE G3-6	SELECTION/DIMENSIONS PAGE G3-23	RELATED PRODUCTS PAGE G3-55
--------------------------------	---------------------------	------------------------------------	--------------------------------



MAXUM Concentric Reducer

Table 5: Easy Selection Table 5 - Separate Reducers 1750 RPM - 1.50 Service Factor

Norm Ratio	Approx Low Speed Shaft RPM	Unit Red.	MAXUM Reducer Size Used with Motor Horsepower of: (With Frame Size References)										
			1	1-1/2	2	3	5	7-1/2	10	15	20	25	
			(143T)	(145T)	(145T)	(182T)	(184T)	(213T)	(215T)	(254T)	(256T)	(284T)	
2.25	777.8	DOUBLE	1	1	1	1	1	1	1	1	1	2	
2.75	636.4		1	1	1	1	1	1	1	1	1	2	
3.37	519.3		1	1	1	1	1	1	1	2	2	2	
4.13	423.7		1	1	1	1	1	1	1	1	1	2	
5.06	345.8		1	1	1	1	1	1	1	1	2	2	
6.20	282.3		1	1	1	1	1	1	1	1	2	2	
7.59	230.6		1	1	1	1	1	1	1	2	2	2	
9.30	188.2		1	1	1	1	1	1	1	2	2	3	
11.39	153.6		1	1	1	1	1	1	1	2	3	3	
13.95	125.4		1	1	1	1	1	1	2	2	3	4	
17.09	102.4		1	1	1	1	1	2	2	3	3	4	
20.93	83.6		1	1	1	1	1	2	2	3	4	4	
25.63	68.3		1	1	1	1	1	2	3	4	4	5	
31.39	55.8		TRIPLE	1	1	1	1	2	2	3	4	4	6
38.44	45.5	1		1	1	1	2	3	3	4	5	6	
47.08	37.2	1		1	1	1	2	3	4	5	6	6	
57.67	30.4	1		1	1	2	3	4	4	6	6	7	
70.62	24.8	1		1	1	2	3	4	5	6	6	7	
86.50	20.2	1		1	2	3	4	4	6	6	7	7	
105.9	16.5	1		2	2	3	4	5	6	7	7	9	
129.7	13.5	1		2	2	3	4	6	6	7	9	9	
158.9	11.0	2		2	3	4	5	6	7	9	9	10	
194.6	9.0	2		3	3	4	6	6	7	9	9	10	
Norm Ratio	Approx Low Speed Shaft RPM	Unit Red.		MAXUM Reducer Size Used with Motor Horsepower of: (With Frame Size References)									
				30	40	50	60	75	100	125	150	200	250
				(286T)	(324T)	(326T)	(364T)	(365T)	(405T)	(444T)	(445T)	(447T)	(449T)
2.25	777.8	DOUBLE		2	3	3	4 ●	4 ●	5 ●	6 ●	6 ●	-	-
2.75	636.4		2	3	3	4	4 ●	5 ●	6 ●	-	-	-	
3.37	519.3		3	3	4	4	5 ●	6 ●	6 ●	-	-	-	
4.13	423.7		2	3	4	4 ●	4 ●	5 ●	6 ●	-	-	-	
5.06	345.8		2	3	4	4 ●	5 ●	5 ●	6 ●	7 ●	7 ●	7 ●	
6.20	282.3		3	4	4	4 ●	5 ●	6 ●	7	7	7 ●	9 ●	
7.59	230.6		3	4	4	5	5 ●	6 ●	7	7	7 ●	9 ●	
9.30	188.2		4	4	4	5 ●	6	7	7	7	9 ●	10 ●	
11.39	153.6		4	4	5	5 ●	6	7	7	7	9 ●	10 ●	
13.95	125.4		4	5	5	6	7	7	7	9 ●	10 ●	10 ●	
17.09	102.4		4	5	6	6	7	7	9	9 ●	10 ●	11 ●	
20.93	83.6		5	6	6	7	7	9 ●	9 ●	10 ●	10 ●	11 ●	
25.63	68.3		6	6	7	7	9	9	9 ●	10 ●	11 ●	11 ●	
31.39	55.8		TRIPLE	6	7	7	9	9	9	10 ●	10 ●	11 ●	12 ●
38.44	45.5	6		7	7	9	9	10	10 ●	11	12 ●	-	
47.08	37.2	7		7	9	9	9	10	11	11 ●	-	-	
57.67	30.4	7		9	9	9	10	11	11	12 ●	-	-	
70.62	24.8	7		9	9	10	10	11	12	-	-	-	
86.50	20.2	9		9	10	10	11	12	-	-	-	-	
105.9	16.5	9		10	10	11	12	-	-	-	-	-	
129.7	13.5	10		10	11	11	12	-	-	-	-	-	
158.9	11.0	10		11	11	12	-	-	-	-	-	-	
194.6	9.0	10		11	12	-	-	-	-	-	-	-	

● Cooling Fan Required

+ TEFC-XE Frame, Energy Efficient Motors

Sizes 1-3 discontinued. Remaining stock may be available

FEATURES/BENEFITS PAGE G3-3	NOMENCLATURE PAGE G3-6	SELECTION/DIMENSIONS PAGE G3-23	RELATED PRODUCTS PAGE G3-55
--------------------------------	---------------------------	------------------------------------	--------------------------------

EASY SELECTION



MAXUM Concentric Reducer

Table 6: Easy Selection - Separate Reducers 1750 RPM - 1.75 Service Factor

Norm Ratio	Approx Low Speed Shaft RPM	Unit Red.	MAXUM Reducer Size Used with Motor Horsepower of: (With Frame Size References)										
			1	1-1/2	2	3	5	7-1/2	10	15	20	25	
			(143T)	(145T)	(145T)	(182T)	(184T)	(213T)	(215T)	(254T)	(256T)	(284T)	
2.25	777.8	DOUBLE	1	1	1	1	1	1	1	1	2	2	
2.75	636.4		1	1	1	1	1	1	1	1	2	2	
3.37	519.3		1	1	1	1	1	1	1	2	2	3	
4.13	423.7		1	1	1	1	1	1	1	1	2	2	
5.06	345.8		1	1	1	1	1	1	1	1	2	2	
6.20	282.3		1	1	1	1	1	1	1	2	2	3	
7.59	230.6		1	1	1	1	1	1	1	2	2	3	
9.30	188.2		1	1	1	1	1	1	1	2	3	3	
11.39	153.6		1	1	1	1	1	1	2	2	3	4	
13.95	125.4		1	1	1	1	1	1	2	3	4	4	
17.09	102.4		1	1	1	1	1	2	2	3	4	4	
20.93	83.6		1	1	1	1	1	2	3	4	4	5	
25.63	68.3	1	1	1	1	2	2	3	4	5	6		
31.39	55.8	TRIPLE	1	1	1	1	2	3	3	4	5	6	
38.44	45.5		1	1	1	1	2	3	4	5	6	6	
47.08	37.2		1	1	1	2	3	4	4	5	6	7	
57.67	30.4		1	1	1	2	3	4	4	6	6	7	
70.62	24.8		1	1	2	2	3	4	5	6	7	7	
86.50	20.2		1	2	2	3	3	5	6	7	7	9	
105.9	16.5		1	2	2	3	4	6	6	7	8	9	
129.7	13.5		1	2	3	4	4	6	7	7	9	10	
158.9	11.0		2	3	3	4	5	6	7	9	9	10	
194.6	9.0		2	3	4	4	6	7	7	9	10	10	
Norm Ratio	Approx Low Speed Shaft RPM		Unit Red.	MAXUM Reducer Size Used with Motor Horsepower of: (With Frame Size References)									
				30	40	50	60	75	100	125	150	200	250
		(286T)		(324T)	(326T)	(364T)	(365T)	(405T)	(444T)	(445T)	(447T)	(449T)	
2.25	777.8	DOUBLE	2	3	4	4●	5●	5●	6●	-	-	-	
2.75	636.4		3	3	4	4	5●	6●	6●	-	-	-	
3.37	519.3		3	3	4	4	5●	6●	-	-	-	-	
4.13	423.7		2	3	4	4●	5●	5●	6●	-	-	-	
5.06	345.8		3	4	4	4●	5●	6●	7	7●	7●	9●	
6.20	282.3		3	4	4	5	5●	7●	7	7	9●	9●	
7.59	230.6		4	4	5	5	6	7●	7	7	9●	10●	
9.30	188.2		4	4	5	5●	6	7	7	7	9●	10●	
11.39	153.6		4	5	5	6	7	7	7	9●	10●	10●	
13.95	125.4		4	5	6	7	7	7	9●	9●	10●	11●	
17.09	102.4		5	6	6	7	7	9	9	10●	10●	11●	
20.93	83.6		5	6	7	7	7	9	10●	10●	11●	11●	
25.63	68.3	6	6	7	7	9	9	10●	10●	11●	12●		
31.39	55.8	TRIPLE	6	7	7	9	9	10	10●	11	12●	-	
38.44	45.5		7	7	9	9	9	10	11	11	11	-	
47.08	37.2		7	9	9	9	10	11	11	11	12●	-	
57.67	30.4		7	9	9	10	10	11	12	-	-	-	
70.62	24.8		9	9	10	10	11	12	-	-	-	-	
86.50	20.2		9	10	10	11	12	-	-	-	-	-	
105.9	16.5		9	10	11	11	12	-	-	-	-	-	
129.7	13.5		10	11	11	12	-	-	-	-	-	-	
158.9	11.0		10	11	12	-	-	-	-	-	-	-	
194.6	9.0		11	12	-	-	-	-	-	-	-	-	

● Cooling Fan Required

+ TEFC-XE Frame, Energy Efficient Motors

■ Sizes 1-3 discontinued. Remaining stock may be available

FEATURES/BENEFITS PAGE G3-3	NOMENCLATURE PAGE G3-6	SELECTION/DIMENSIONS PAGE G3-23	RELATED PRODUCTS PAGE G3-55
--------------------------------	---------------------------	------------------------------------	--------------------------------



MAXUM Concentric Reducer

Table 7: Easy Selection - Separate Reducers 1750 RPM - 2.0 Service Factor

Norm Ratio	Approx Low Speed Shaft RPM	Unit Red.	MAXUM Reducer Size Used with Motor Horsepower of: (With Frame Size References)									
			1	1-1/2	2	3	5	7-1/2	10	15	20	25
			(143T)	(145T)	(145T)	(182T)	(184T)	(213T)	(215T)	(254T)	(256T)	(284T)
2.25	777.8	DOUBLE	1	1	1	1	1	1	1	1	2	2
2.75	636.4		1	1	1	1	1	1	1	1	2	3
3.37	519.3		1	1	1	1	1	1	1	2	2	3
4.13	423.7		1	1	1	1	1	1	1	2	2	2
5.06	345.8		1	1	1	1	1	1	1	2	2	3
6.20	282.3		1	1	1	1	1	1	1	2	2	3
7.59	230.6		1	1	1	1	1	1	1	2	3	3
9.30	188.2		1	1	1	1	1	1	2	2	3	4
11.39	153.6		1	1	1	1	1	1	2	3	3	4
13.95	125.4		1	1	1	1	1	2	2	3	4	4
17.09	102.4		1	1	1	1	1	2	3	3	4	4
20.93	83.6		1	1	1	1	2	2	3	4	4	5
25.63	68.3		1	1	1	1	2	3	3	4	5	6
31.39	55.8		TRIPLE	1	1	1	1	2	3	4	4	6
38.44	45.5	1		1	1	2	3	3	4	5	6	6
47.08	37.2	1		1	1	2	3	4	4	6	6	7
57.67	30.4	1		1	2	2	3	4	5	6	7	7
70.62	24.8	1		1	2	3	4	5	6	6	7	9
86.50	20.2	1		2	2	3	4	6	6	7	9	9
105.9	16.5	1		2	3	4	5	6	6	7	9	9
129.7	13.5	2		2	3	4	6	6	7	9	9	10
158.9	11.0	2		3	3	4	6	7	7	9	10	10
194.6	9.0	2		3	4	5	6	7	9	9	10	11
Norm Ratio	Approx Low Speed Shaft RPM	Unit Red.	MAXUM Reducer Size Used with Motor Horsepower of: (With Frame Size References)									
			30	40	50	60	75	100	125	150	200	250
			(286T)	(324T)	(326T)	(364T)	(365T)	(405T)	(444T)	(445T)	(447T)	(449T)
2.25	777.8	DOUBLE	3	3	4	4 ●	5 ●	6 ●	-	-	-	-
2.75	636.4		3	3	4	4	5 ●	6 ●	-	-	-	-
3.37	519.3		3	4	4	5	6	-	-	-	-	-
4.13	423.7		3	4	4	4 ●	5 ●	6 ●	-	-	-	-
5.06	345.8		3	4	4	5	5 ●	7	7	7 ●	7 ●	9 ●
6.20	282.3		4	4	5	5	6	7	7	7	9 ●	10 ●
7.59	230.6		4	4	5	5	6	7	7	7	9 ●	10 ●
9.30	188.2		4	5	5	6	7	7	7	9 ●	10 ●	10 ●
11.39	153.6		4	5	6	7	7	7	9 ●	9 ●	10 ●	11 ●
13.95	125.4		5	6	6	7	7	9	9	10 ●	10 ●	11 ●
17.09	102.4		5	6	7	7	7	9	10	10 ●	11 ●	11 ●
20.93	83.6		6	7	7	7	9	9	10 ●	10 ●	11 ●	12 ●
25.63	68.3		6	7	7	9	9	10	10 ●	11 ●	12 ●	-
31.39	55.8		TRIPLE	7	7	9	9	9	10	11	11	12 ●
38.44	45.5	7		9	9	9	10	10	11	11	12	-
47.08	37.2	7		9	9	10	10	11	12	-	-	-
57.67	30.4	9		9	10	10	11	12	-	-	-	-
70.62	24.8	9		10	10	11	11	-	-	-	-	-
86.50	20.2	9		10	10	11	12	-	-	-	-	-
105.9	16.5	10		10	11	12	-	-	-	-	-	-
129.7	13.5	10		11	12	-	-	-	-	-	-	-
158.9	11.0	11		12	-	-	-	-	-	-	-	-
194.6	9.0	11		-	-	-	-	-	-	-	-	-

● Cooling Fan Required

+ TEFC-XE Frame, Energy Efficient Motors

Shaded cells: Sizes 1-3 discontinued. Remaining stock may be available

FEATURES/BENEFITS PAGE G3-3	NOMENCLATURE PAGE G3-6	SELECTION/DIMENSIONS PAGE G3-23	RELATED PRODUCTS PAGE G3-55
--------------------------------	---------------------------	------------------------------------	--------------------------------

EASY SELECTION



MAXUM Concentric Reducer

EASY SELECTION METHOD – SCOOP MOUNT MOTORS/REDUCERS (for 1750 RPM motors)

When to Use Easy Selection

The Easy Selection tables for Scoop Mount Motors/Reducers are for electric motor selections up to 250 HP with constant input speeds of 1750 rpm using AGMA recommended load classifications. For all other motor/prime mover input speeds and horsepowers, use the Horsepower/Torque Selection Method on page G3-57 through G3-58.

NOTE: If your application has unusual requirements (i.e., variable speed, excessive shock or over loads, extreme ambient temperatures, non-standard motors or oversized equipment), refer to Horsepower/Torque Selection Method.

How to Select

Step 1: Determine Load Classification – See Table 8 to determine minimum load classification for applications under normal conditions.

Example: Easy Selection Method - SCOOP MOUNT MOTORS/REDUCERS

A 30 horsepower motor is used to drive a metal mill non-reversing table conveyor at 100 rpm operating 12 hours per day. The reducer is coupling connected at both the high speed and low speed shafts and the motor is to be supported by a scoop. A PARA-FLEX coupling is desired.

Step 1: Determine Load Classification - Refer to Table 8 and note that “Metal Mills - Table Conveyors, Non-Reversing” requires a Class III Load Classification for 10+ hours/day service.

Step 2: Determine Unit Size - Turn to the Easy Selection Table (Table 11) for Class III service. Under 30 motor horsepower and opposite 102.4 rpm, locate the MAXUM Size 5 reducer and note the nominal ratio is 17.09:1. Also note that the motor frame size is 286T

NOTE: AGMA classifies scoop mounted motors as gear motor applications which are sized using a load classification in place of a service factor.

Step 2: Determine Unit Size – See tables on pages G3-20 through G3-22. Find the load classification table that is required for the application. Read the unit size under required horsepower and opposite the required low speed shaft RPM. **Note:** For applications where fan cooling is unacceptable, use an Easy Selection Table with an increased class of service.

Step 3: Check External Thrust and Overhung Load – See information on page G3-59 to calculate high speed and low speed shaft overhung loads.

Step 4: Check Dimensions – See Specification/Dimensions section pages G3-23 through G3-33 for dimensions, weights, and part numbers.

Step 5: Select Accessories – Check matrix for compatibility of combinations of accessories, page G3-34.

Step 3: Check External Thrust and Overhung Loads - Since the input and output shafts are coupling connected, thrust and overhung loads will not exist. (An overhung load example is given on page G3-59)

Step 4: Check Dimensions and Part Numbers - The dimensions are shown under “Scoop Mount Motor/Reducers with AC motors Sizes 5-9” page G3-59. Part numbers can be found on the DODGE MAXUM Size 5 Specifications/Dimensions page G3-27. The Reducer part number is 299102.

Step 5: Select Accessories - The accessories are also found on the DODGE MAXUM Size 5 Specifications/Dimensions page G3-27. The Scoop Package part number is DCS05280P and includes the scoop, coupling, coupling guard and mounting hardware.

Drive System Vibration

The probability of a constant speed motor operating at resonant frequency is remote. Should this occur, however, the customer must add stiffening supports to the scoop bottom plate to move the resonant frequency away from the motor operating speed.

When mounting variable speed AC or DC motors, consult guidelines on pages G3-81 through G3-82.

CAUTION: The customer is responsible and Reliance Electric expressly disclaims responsibility for isolating the DODGE MAXUM Scoop Mount Motor/Reducer from any vibratory or transient load induced by the motor or the other equipment that is driven by the motor.

The MAXUM Scoop Mount Motor/Reducer is expressly not warranted against failure or unsatisfactory operation resulting from dynamic vibrations of any form imposed upon it whether by the drive system in which it is installed or for any other reason, no matter how induced, unless the nature of such vibrations has been fully defined by the customer on the face of its purchase order and explicitly accepted in writing by DODGE.

FEATURES/BENEFITS
PAGE G3-3

NOMENCLATURE
PAGE G3-6

SELECTION/DIMENSIONS
PAGE G3-23

RELATED PRODUCTS
PAGE G3-55



MAXUM Concentric Reducer LOAD CLASSIFICATIONS

The load classifications that follow are adapted from AGMA 6019-E89 Appendix A. Class numbers are minimums and normal conditions are assumed.

Applications which expose the gear drive to high starting torques, extreme repetitive shock, or where high energy loads must be absorbed as when stalling, require special consideration. Load classifications for these special applications should be agreed upon by the user and DODGE

since variations of the values in the table may be required.

The load classifications in the table are based upon the use of electric motors with characteristics normally used for that application. Should motors with unusually high starting torques or motors designed for intermittent service be used, adjustments in the load classification selected may be required. Consult DODGE

Table 8: Load Classification For Scoop Mounted Motor/Reducers

APPLICATION	SERVICE		APPLICATION	SERVICE		APPLICATION	SERVICE	
	3-10 Hrs. / Day	10+ Hrs. / Day		3-10 Hrs. / Day	10+ Hrs. / Day		3-10 Hrs. / Day	10+ Hrs. / Day
AGITATORS			BRICK PRESS (Clay Working)	III	III	CONVERTING MACHINES (Paper)		II
Paper Mills	II	II	BRIQUETTE MACHINES (Clay Working)	III	III	CONVEYORS - Uniformly Loaded or Fed: Apron		
Pure Liquids	II	II	BUCKET			Assembly, Belt		
Liquids & Solids	II	II	Conveyors Uniform	I	II	Bucket, Chain, Flight		
Liquids - Variable Density	II	II	Conveyors Heavy Duty	I	II	Oven, Screw	I	II
APRON CONVEYORS			Elevators Cont.	I	II	CONVEYORS - Heavy Duty Not Uniformly Fed:		
Uniformly Loaded or Fed	I	II	Elevators Uniform	I	II	Apron, Assembly, Belt		
Heavy Duty	II	II	Elevators Heavy Duty	II	II	Bucket, Chain, Flight		
ASSEMBLY CONVEYORS			CALENDERS			Oven, Screw		
Uniformly Loaded or Fed	I	II	Paper (2)		II	Live Roll (Package)	I	II
Heavy Duty	II	II	Super (Paper) (3)		II	Reciprocating, Shaker	III	III
BALL MILLS	▲	▲	Rubber	II	II	COOKERS (Brewing & Distilling) (Food)	II	II
BARGE HAUL PULLERS	II	II	Textile	II	II	COUCH (Paper)		II
BARKING			CANE KNIVES	II	II	CRANES	†	†
Drums		III	CAN FILLING MACHINES	II	II	CRUSHERS		
Hydraulic Auxiliaries		III	CARD MACHINES (Textile)	II	II	Ore or Stone	III	III
Mechanical		III	CAR DUMPERS	III	III	CUTTERS (Paper)		III
BAR SCREENS (Sewage)	II	II	CAR PULLERS	II	II	CYLINDERS (Paper)		II
BATCHERS (Textile)	II	II	CEMENT KILNS	▲	▲	DEWATERING SCREENS (Sewage)	II	II
BEATERS (Paper)		II	CENTRIFUGAL			DISC FEEDERS	I	II
BELT CONVEYORS			Blowers, Compressors			DISTILLING (See Brewing)		
Uniformly Loaded or Fed	I	II	Discharge Elevators	I	II	DOUBLE ACTING PUMPS		
Heavy Duty	II	II	Fans or Pumps			2 or More Cylinders	II	II
BELT FEEDERS	II	II	CHAIN CONVEYORS			Single Cylinder	†	†
BENDING ROLLS (Machine)	II	II	Uniformly Loaded or Fed	I	II	DOUGH MIXER (Food)	II	II
BLEACHERS (Paper)		II	Heavy Duty	II	II	DRAW BENCH (Metal Mills)		
BLOWERS			CHEMICAL FEEDERS (Sewage)	II	II	Carriage & Main Drive	II	II
Centrifugal	I	II	CLARIFIERS	I	II	DREDGES		
Lobe	II	II	CLASSIFIERS	II	II	Cable Reels	II	II
Vane	II	II	CLAY WORKING IND. Brick Press	III	III	Conveyors	II	II
BOTTLING MACHINERY	I	II	Briquette Machines	III	III	Cutter Head Drives	III	III
BREWING & DISTILLING			Pug Mills	II	II	Jig Drives	III	III
Bottling Machinery	I	II	COLLECTORS (Sewage)	II	II	Maneuvering Winches	III	III
Brew Kettle, Cont. Duty		II	COMPRESSORS			Pumps	III	III
Can Filling Machines	I	II	Centrifugal	I	II	Screen Drives	III	III
Cookers - Cont. Duty	II	II	Lobe	II	II	Stackers	II	II
Mash Tubs - Cont. Duty	II	II	Reciprocating:			Utility Winches	II	II
Scale Hoppers - Frequent Starts	II	II	Multi-Cylinder	II	III	DRYERS (Paper) (2)		
			Single Cylinder	III	III	DRYERS & COOLERS (Mills, Rotary)	▲	▲
			CONCRETE MIXERS					
			Continuous	II	II			
			Intermittent	II	II			

† - Consult DODGE

▲ - See Mills, Rotary

FEATURES/BENEFITS PAGE G3-3	NOMENCLATURE PAGE G3-6	SELECTION/DIMENSIONS PAGE G3-23	RELATED PRODUCTS PAGE G3-55
--------------------------------	---------------------------	------------------------------------	--------------------------------



EASY SELECTION

MAXUM Concentric Reducer

Table 8 - Load Classification (cont'd)

APPLICATION	SERVICE		APPLICATION	SERVICE		APPLICATION	SERVICE	
	3-10 Hrs. / Day	10+ Hrs. / Day		3-10 Hrs. / Day	10+ Hrs. / Day		3-10 Hrs. / Day	10+ Hrs. / Day
DYEING MACHINERY (Textile)	II	II	LOOMS (Textile)	II	II	Helical Ring Gear	II	II
ELEVATORS			LUMBER INDUSTRY			Direct Connected	III	III
Bucket - Uniform Load	I	II	Barkers - Spindle Feed	II	II	Cement Kilns	II	II
Bucket - Heavy Duty	II	II	Barkers - Main Drive	II	III	Dryers & Coolers	II	II
Centrifugal Discharge	I	II	Carriage Drive	†	†	Tumbling Barrels	III	III
Escalators	I	II	Conveyors			MIXERS (Also see Agitators)		
Freight	II	II	Burner	II	II	Concrete, Continuous	II	II
Gravity Discharge	I	II	Main or Heavy Duty	II	II	Concrete, Intermittent	II	II
Man Lifts, Passenger	†	†	Main Log	III	III	Constant Density	I	I
ESCALATORS	I	II	Re-Saw Merry-Go-			Variable Density	II	II
FANS			Slab	III	III	NAPPERS (Textile)	II	II
Centrifugal	I	II	Transfer	II	II	OIL INDUSTRY		
Cooling Towers	†	†	Chains - Floor	II	II	Chillers	II	II
Forced Draft	II	II	Chains - Green	II	III	Oil Well Pumping	†	†
Induced Draft	II	II	Cut-Off Saws - Chain	II	III	Paraffin Filter Press	II	II
Large (Mine, etc.)	II	II	Cut-Off Saws - Drag	II	III	Rotary Kilns	II	II
Large Industrial	II	II	Debarking Drums	III	III	ORE CRUSHERS	III	III
FEEDERS			Feeds - Edger	II	II	OVEN CONVEYORS		
Apron, Belt	II	II	Feeds - Gang	III	III	Uniform	I	I
Disc	I	II	Feeds - Trimmer	II	II	Heavy Duty	II	II
Reciprocating	III	III	Log Deck	II	III	PAPER MILLS		
Screw	II	II	Log Hauls - Incline, Well Type	III	III	Agitators (Mixers)	II	II
FELT			Log Turning Devices	III	III	Barker - Auxiliaries - Hyd.		
Stretchers (Paper)		II	Planer Feed	II	II	Barker, Mechanical		III
Whippers (Paper)		III	Planer Tilting Hoists	II	II	Barking Drum		III
FLIGHT			Rolls - Live - Off			Beater		II
Conveyors, Uniform	I	II	Bearing - Roll Cases	III	III	Bleacher		II
Conveyors, Heavy	II	II	Sorting Table	II	II	Converting Machine - Except Cutters-Platers		II
FOOD INDUSTRY			Tipple Hoist	II	II	Conveyors (Chip, Bark, Chemical)		
Beet Slicers	II	II	Transfer - Chain	II	III	Couch		II
Bottling, Can Filling Machine	I	II	Transfer - Craneway	II	III	Cutters, Platers		III
Cereal Cookers	I	II	Tray Drives	II	II	Cylinders		II
Dough Mixers	II	II	MACHINE TOOLS			Felt Stretchers		II
Meat Grinders	II	II	Auxiliary Drives	I	II	Felt Whippers		III
FORMING MACHINES (Metal Mills)	III	III	Bending Rolls	II	II	Jordans		II
GENERATORS (Not Welding)	II	II	Main Drives	II	II	Log Haul		III
GRAVITY DISCHARGE ELEVATORS	I	II	Notching Press (Belted)	†	†	Presses		II
GRIT COLLECTORS (Sewage)	II	II	Plate Planers	III	III	Pulper		III
HAMMER MILLS	III	III	Punch Press (Gearing)	III	III	Pulp Machine Reels		II
HOISTS	†	†	Tapping Machines	III	III	Stock Chests		II
INDUCED DRAFT FANS	II	II	MANGLE (Textile)	II	II	Suction Rolls		II
JORDANS (Paper)	II	II	MASH TUBS (Brewing & Distilling)	II	II	Washers & Thickeners		II
KILNS (Mills, Rotary)			MEAT GRINDERS (Food)	II	II	Winders		II
Cement	▲	▲	METAL MILLS			PASSENGER ELEVATORS	†	†
LAUNDRY TUMBLERS	II	II	Draw Bench Carriages & Main Drives	II	II	PEBBLE MILLS	▲	▲
LAUNDRY WASHERS	II	III	Forming Machines	III	III	PLASTICS INDUSTRY		
LINE SHAFTS			Pinch, Dryer & Scrubber			Primary Processing		
Heavy Shock Load	III	III	Rolls Reversing	†	†	Intensive Internal Mixers		
Moderate Shock Load	II	II	Slitters	II	II	Batch Mixers	III	III
Uniform Load	I	II	Table Conveyors, Non-Reversing	II	III	Continuous Mixers	II	II
LIVE ROLL CONVEYORS			Reversing	†	†	Batch Drop Mill - 2 Smooth Rolls	II	II
Package	I	II	Wire Drawing & Flattening Machines	II	II	Continuous Feed, Holding & Blend Mill	II	II
LOBE BLOWERS OR COMPRESSORS	II	II	Wire Winding Machines	II	II	Calenders	II	II
LOG HAULS (Paper & Lumber)	III	III	MILLS, ROTARY TYPE			Secondary Processing		
			Ball and Rod			Blow Molders	II	II
			Spur Ring Gear	III	III			

† - Consult DODGE

▲ - See Mills, Rotary

FEATURES/BENEFITS PAGE G3-3	NOMENCLATURE PAGE G3-6	SELECTION/DIMENSIONS PAGE G3-23	RELATED PRODUCTS PAGE G3-55
--------------------------------	---------------------------	------------------------------------	--------------------------------



MAXUM Concentric Reducer

Table 8 - Load Classification (cont'd)

APPLICATION	SERVICE		APPLICATION	SERVICE		APPLICATION	SERVICE	
	3-10 Hrs. / Day	10+ Hrs. / Day		3-10 Hrs. / Day	10+ Hrs. / Day		3-10 Hrs. / Day	10+ Hrs. / Day
Coating	II	II	1 or 2 corrugated rolls	III	III	SPINNERS (Textile)	II	II
Film	II	II	Batch Drop Mill -			STEERING GEARS	†	†
Pipe	II	II	2 Smooth Rolls	II	II	STOCK CHESTS (Paper)		II
Pre-Plasticizers	II	II	Cracker Warmer - 2			STOKERS	I	I
Rods	II	II	Rolls; 1 Corrugated Roll	III	III	STONE CRUSHERS	III	III
Sheet	II	II	Cracker - 2 Corrugated			SUCTION ROLLS (Paper)		II
Tubing	II	II	Rolls	III	III	TABLE CONVEYORS		
PLATE PLANERS	III	III	Holding, Feed & Blend			(Metal Mills)		
PRESSES (Paper)			Mill - 2 Rolls	II	II	Non-Reversing	II	III
PROPORTIONING PUMPS	II	II	Refiner-2 Rolls	II	II	Reversing	†	†
PUG MILLS (Clay)	II	II	Calenders	II	II	TEXTILE INDUSTRY		
PULLERS (Barge Haul)	II	II	SAND MULLERS	II	II	Batchers	II	II
PULP MACHINE REELS			SCREENS			Calenders	II	II
PUMPS			Air Washing	I	II	Card Machines	II	II
Centrifugal	I	II	Rotary - Sand or Gravel	II	II	Cloth Finishing Mach.,		
Proportioning	II	II	Traveling Water Intake	I	II	(Calenders, Dryers,		
Reciprocating			SCREW CONVEYORS			Pads, Tenters,"		
"Single Act., 3 or"			Uniform	I	I	Washers)	II	II
More Cyl.	II	II	Heavy Duty or Feeder	II	II	Dry Cans	II	II
"Double Act., 2 or"			SEWAGE DISPOSAL			Dyeing Machinery	II	II
More Cyl.	II	II	Aerators	†	†	Knitting Machinery	†	†
Single Act., 1 or 2 Cyl.	†	†	Bar Screens	II	II	Looms, Mangles,		
"Rotary: Gear, Lobe, Vane"	I	II	Chemical Feeders	II	II	Nappers	II	II
PUNCH PRESSES			Collectors	II	II	Range Drives	†	†
(Gear Driven)	III	III	Dewatering Screens	II	II	Tenter Frames	II	II
RECIPROCATING			Grit Collectors	II	II	Winders	II	II
"Conveyors, Feeders"	III	III	Scum Breakers	II	II	Yarn Preparatory		
RECIPROCATING			Slow or Rapid Mixers	II	II	Machinery (Cards, Soapers,		
COMPRESSORS			Sludge Collectors	II	II	Spinners, Slashers)	II	II
Multi Cylinder	II	III	Thickeners	II	II	THICKENERS (Sewage)	II	II
Single Cylinder	III	III	Vacuum Filters	II	II	TUMBLING BARRELS	III	III
REVERSING DIRECTION			SHAKER CONVEYORS	III	III	VACUUM FILTERS		
APPLICATION	†	†	SHEETERS (Rubber)	II	II	(Sewage)	II	II
ROD MILLS	▲	▲	SINGLE ACTING PUMP			VANE BLOWERS	II	II
ROTARY			1 or 2 Cylinders	†	†	WINCHES (Dredges)	II	II
Pumps: Gear, Lobe,			3 or More Cylinders	II	II	WINDERS		
Vane	I	II	SKIP HOIST	II	II	(Paper)		II
Screens (Sand or Gravel)	II	II	SLAB PUSHERS	II	II	(Textile)	II	II
RUBBER INDUSTRY			SLITTERS (Metal)	II	II	WINDLASS	II	II
Intensive Internal Mixers			SLUDGE COLLECTORS			WIRE		
Batch Mixers	III	III	(Sewage)	II	II	Drawing Machines	II	II
Continuous Mixers	II	II	SOAPERS (Textile)	II	II	Winding Machines	II	II
Mixing Mill								
2 smooth rolls	II	II						

† - Consult DODGE

▲ - See Mills, Rotary

Reference: AGMA Standard 6021-G89 (11/89). The table of application class numbers has been developed from the experience of manufacturers and users of gear drives for use in common applications and has been found to be generally satisfactory for the listed industries when gears are rated using AGMA standards. It is recommended that class numbers for special applications be agreed upon by the user and the gear manufacturer when variations of the table may be required. Special conditions can be any special type of prime mover, starting or stopping conditions, system conditions, ambient conditions, lubrication, overloads, overspeeds, brake equipped applications, high inertia and reversing loads.

FEATURES/BENEFITS PAGE G3-3	NOMENCLATURE PAGE G3-6	SELECTION/DIMENSIONS PAGE G3-23	RELATED PRODUCTS PAGE G3-55
--------------------------------	---------------------------	------------------------------------	--------------------------------

EASY SELECTION



MAXUM Concentric Reducer

Table 9: Easy Selection - Scoop Mount Motors/Reducers 1750 RPM - Class I Service (1.0 Service Factor) ■

Nom Ratio	Approx Low Speed Shaft RPM	Unit Red.	MAXUM Reducer Size Used with Motor Horsepower of: (With Frame Size References)										
			1	1-1/2	2	3	5	7-1/2	10	15	20	25	
			(143T)	(145T)	(145T)	(182T)	(184T)	(213T)	(215T)	(254T)	(256T)	(284T)	
2.25	777.8	DOUBLE	1	1	1	1	1	1	1	2	2	3	
2.75	636.4		1	1	1	1	1	1	1	2	2	3	
3.37	519.3		1	1	1	1	1	1	1	2	2	3	
4.13	423.7		1	1	1	1	1	1	1	2	2	3	
5.06	345.8		1	1	1	1	1	1	1	2	2	3	
6.20	282.3		1	1	1	1	1	1	1	2	2	3	
7.59	230.6		1	1	1	1	1	1	1	2	2	3	
9.30	188.2		1	1	1	1	1	1	1	2	2	3	
11.39	153.6		1	1	1	1	1	1	1	2	2	3	
13.95	125.4		1	1	1	1	1	1	1	2	2	3	
17.09	102.4		1	1	1	1	1	1	1	2	3	3	
20.93	83.6		1	1	1	1	1	1	1	2	2	3	
25.63	68.3	1	1	1	1	1	1	1	2	3	4		
31.39	55.8	TRIPLE	1	1	1	1	1	2	2	3	4	4	
38.44	45.5		1	1	1	1	1	2	3	3	4	4	
47.08	37.2		1	1	1	1	2	2	3	4	4	5	
57.67	30.4		1	1	1	1	2	3	3	4	5	6	
70.62	24.8		1	1	1	1	2	3	4	5	6	6	
86.50	20.2		1	1	1	2	3	4	4	6	6	6	
105.9	16.5		1	1	1	2	3	4	5	6	6	7	
129.7	13.5		1	1	2	2	4	4	6	6	7	7	
158.9	11.0		1	2	2	3	4	5	6	7	7	9	
194.6	9.0		1	2	2	3	4	6	6	7	9	9	
Nom Ratio	Approx Low Speed Shaft RPM		Unit Red.	MAXUM Reducer Size Used with Motor Horsepower of: (With Frame Size References)									
				30	40	50	60	75	100	125	150	200	250
		(286T)		(324T)	(326T)	(364T)	(365T)	(405T)	(444T)	(4455T)	(447T)	(449T)	
2.25	777.8	DOUBLE	3	4	4	5●	5●	-	-	-	-	-	
2.75	636.4		3	4	4	5	5●	-	-	-	-	-	
3.37	519.3		3	4	4	5	5●	-	-	-	-	-	
4.13	423.7		3	4	4	5●	5●	-	-	-	-	-	
5.06	345.8		3	4	4	5	5●	7	7	7●	7●	7●	
6.20	282.3		3	4	4	5	5●	7	7	7	7●	7●	
7.59	230.6		3	4	4	5	5●	7	7	7	7●	7●	
9.30	188.2		3	4	4	5●	5●	7	7	7●	7●	7●	
11.39	153.6		3	4	4●	5●	5●	7	7	7●	7●	9●	
13.95	125.4		3	4	4●	5●	5●	7	7	7●	9●	9●	
17.09	102.4		3	4	4●	5●	6●	7	7●	7●	9●	10●	
20.93	83.6		4	4●	5●	6●	6●	7	7●	9●	9●	10●	
25.63	68.3	4	5●	6	6●	7	7	9●	9●	10●	10●		
31.39	55.8	TRIPLE	4	6	6	7	7	9	9	9●	10●	11●	
38.44	45.5		5	6	6	7	7	9	9●	10●	10●	11●	
47.08	37.2		6	6	7	7	9	9	10●	10●	11●	12●	
57.67	30.4		6	7	7	9	9	10●	10●	11●	12●	-	
70.62	24.8		6	7	9	9	9	10●	11●	11●	-	-	
86.50	20.2		7	9	9	9	10	10	11	12	-	-	
105.9	16.5		7	9	9	10	10	11	12	-	-	-	
129.7	13.5		9	9	10	10	11	12	-	-	-	-	
158.9	11.0		9	10	10	11	11	-	-	-	-	-	
194.6	9.0		9	10	11	11	12	-	-	-	-	-	

■ Some reducers selections are oversized to accommodate scoop mounting of motor on reducers
 ● Cooling fan required + TEFC-XE Frame, Energy Efficient Motors
 Note: The suggested mounting for motors weighing 700 pounds or more is the MAXUM HD baseplate. See page G3-38

■ Sizes 1-3 discontinued. Remaining stock may be available

FEATURES/BENEFITS PAGE G3-3	NOMENCLATURE PAGE G3-6	SELECTION/DIMENSIONS PAGE G3-23	RELATED PRODUCTS PAGE G3-55
--------------------------------	---------------------------	------------------------------------	--------------------------------



MAXUM Concentric Reducer

Table 10: Easy Selection - Scoop Mount Motors/Reducers 1750 RPM - Class II Service (1.4 Service Factor) ■

Nom Ratio	Approx Low Speed Shaft RPM	Unit Red.	MAXUM Reducer Size Used with Motor Horsepower of: (With Frame Size References)										
			1	1-1/2	2	3	5	7-1/2	10	15	20	25	
			(143T)	(145T)	(145T)	(182T)	(184T)	(213T)	(215T)	(254T)	(256T)	(284T)	
2.25	777.8	DOUBLE	1	1	1	1	1	1	1	2	2	3	
2.75	636.4		1	1	1	1	1	1	1	2	2	3	
3.37	519.3		1	1	1	1	1	1	1	2	2	3	
4.13	423.7		1	1	1	1	1	1	1	2	2	3	
5.06	345.8		1	1	1	1	1	1	1	2	2	3	
6.20	282.3		1	1	1	1	1	1	1	2	2	3	
7.59	230.6		1	1	1	1	1	1	1	2	2	3	
9.30	188.2		1	1	1	1	1	1	1	2	2	3	
11.39	153.6		1	1	1	1	1	1	1	2	3	3	
13.95	125.4		1	1	1	1	1	1	2	2	3	4	
17.09	102.4		1	1	1	1	1	1	2	3	3	4	
20.93	83.6		1	1	1	1	1	2	2	3	4	4	
25.63	68.3		1	1	1	1	1	2	3	3	4	5	
31.39	55.8		TRIPLE	1	1	1	1	2	2	3	4	4	5
38.44	45.5			1	1	1	1	2	3	3	4	5	6
47.08	37.2	1		1	1	1	2	3	4	4	6	6	
57.67	30.4	1		1	1	2	3	3	4	5	6	6	
70.62	24.8	1		1	1	2	3	4	4	6	6	7	
86.50	20.2	1		1	2	2	3	4	5	6	7	7	
105.90	16.5	1		1	2	3	4	5	6	7	7	9	
129.70	13.5	1		2	2	3	4	6	6	7	9	9	
158.90	11.0	1		2	3	4	5	6	7	7	9	9	
194.60	9.0	2		3	3	4	6	6	7	9	9	10	
Nom Ratio	Approx Low Speed Shaft RPM	Unit Red.		MAXUM Reducer Size Used with Motor Horsepower of: (With Frame Size References)									
				30	40	50	60	75	100	125	150	200	250
				(286T)	(324T)	(326T)	(364T)	(365T)	(405T)	(444T)	(4455T)	(447T)	(449T)
2.25	777.8	DOUBLE		3	4	4	5 ●	5 ●	-	-	-	-	-
2.75	636.4			3	4	4	5	5 ●	-	-	-	-	-
3.37	519.3		3	4	4	5	5 ●	-	-	-	-	-	
4.13	423.7		3	4	4	5 ●	5 ●	-	-	-	-	-	
5.06	345.8		3	4	4	5	5 ●	7	7 ●	7 ●	7 ●	7 ●	
6.20	282.3		3	4	4	5	5 ●	7	7	7	7 ●	9 ●	
7.59	230.6		3	4	4	5	5 ●	7	7	7	7 ●	9 ●	
9.30	188.2		3	4	4	5 ●	5 ●	7	7	7 ●	9 ●	9 ●	
11.39	153.6		4	4	5	5 ●	6	7	7	7 ●	9 ●	10 ●	
13.95	125.4		4	4	5	6	7	7	7	9 ●	9 ●	10 ●	
17.09	102.4		4	5	6	6	7	7	9 ●	9 ●	10 ●	10 ●	
20.93	83.6		4	6	6	7	7	9 ●	9 ●	9 ●	10 ●	11 ●	
25.63	68.3		5	6	6	7	7	9	9 ●	10 ●	11 ●	11 ●	
31.39	55.8		TRIPLE	6	6	7	7	9	9	10 ●	10 ●	11 ●	12 ●
38.44	45.5			6	7	7	9	9	10	10 ●	11	12 ●	-
47.08	37.2	6		7	9	9	9	10 ●	11	11 ●	12 ●	-	
57.67	30.4	7		9	9	9	10	10 ●	11	12 ●	-	-	
70.62	24.8	7		9	9	10	10	11	12	-	-	-	
86.50	20.2	9		9	10	10	11	12	-	-	-	-	
105.90	16.5	9		10	10	11	11	-	-	-	-	-	
129.70	13.5	9		10	11	11	12	-	-	-	-	-	
158.90	11.0	10		10	11	12	-	-	-	-	-	-	
194.60	9.0	10		11	12	-	-	-	-	-	-	-	

■ Some reducers selections are oversized to accommodate scoop mounting of motor on reducers
 ● Cooling fan required + TEFC-XE Frame, Energy Efficient Motors
 Note: The suggested mounting for motors weighing 700 pounds or more is the MAXUM HD baseplate. See page G3-38

■ Sizes 1-3 discontinued. Remaining stock may be available

FEATURES/BENEFITS PAGE G3-3	NOMENCLATURE PAGE G3-6	SELECTION/DIMENSIONS PAGE G3-23	RELATED PRODUCTS PAGE G3-55
--------------------------------	---------------------------	------------------------------------	--------------------------------

EASY SELECTION



MAXUM Concentric Reducer ■

Table 11: Easy Selection - Scoop Mount Motor/Reducers - 1750 RPM - Class II Service (2.0 Service Factor)

Nom Ratio	Approx Low Speed Shaft RPM	Unit Red.	MAXUM Reducer Size Used with Motor Horsepower of: (With Frame Size References)										
			1	1-1/2	2	3	5	7-1/2	10	15	20	25	
			(143T)	(145T)	(145T)	(182T)	(184T)	(213T)	(215T)	(254T)	(256T)	(284T)	
2.25	777.8	DOUBLE	1	1	1	1	1	1	1	2	2	3	
2.75	636.4		1	1	1	1	1	1	1	2	2	3	
3.37	519.3		1	1	1	1	1	1	1	2	2	3	
4.13	423.7		1	1	1	1	1	1	1	2	2	3	
5.06	345.8		1	1	1	1	1	1	1	2	2	3	
6.2	282.3		1	1	1	1	1	1	1	2	2	3	
7.59	230.6		1	1	1	1	1	1	1	2	3	3	
9.3	188.2		1	1	1	1	1	1	2	2	3	4	
11.39	153.6		1	1	1	1	1	1	2	3	3	4	
13.95	125.4		1	1	1	1	1	2	2	3	4	4	
17.09	102.4		1	1	1	1	1	2	3	3	4	4	
20.93	83.6		1	1	1	1	2	2	3	4	4	5	
25.63	68.3		1	1	1	1	2	3	3	4	5	6	
31.39	55.8	TRIPLE	1	1	1	1	2	3	4	4	6	6	
38.44	45.5		1	1	1	2	3	3	4	5	6	6	
47.08	37.2		1	1	1	2	3	4	4	6	6	7	
57.67	30.4		1	1	2	2	3	4	5	6	7	7	
70.62	24.8		1	1	2	3	4	5	6	6	7	9	
86.5	20.2		1	2	2	3	4	6	6	7	9	9	
105.9	16.5		1	2	3	4	5	6	6	7	9	9	
129.7	13.5		2	2	3	4	6	6	7	9	9	10	
158.9	11		2	3	3	4	6	7	7	9	10	10	
194.6	9		2	3	4	5	6	7	9	9	10	11	
Nom Ratio	Approx Low Speed Shaft RPM		Unit Red.	MAXUM Reducer Size Used with Motor Horsepower of: (With Frame Size References)									
				30	40	50	60	75	100	125	150	200	250
				(286T)	(324T)	(326T)	(364T)	(365T)	(405T)	(444T)	(4455T)	(447T)	(449T)
2.25	777.8	DOUBLE	3	4	4	5●	5●	-	-	-	-	-	
2.75	636.4		3	4	4	5	5●	-	-	-	-	-	
3.37	519.3		3	4	4	5	6	-	-	-	-	-	
4.13	423.7		3	4	4	5●	5●	-	-	-	-	-	
5.06	345.8		3	4	4	5	5●	7	7	7●	7●	9●	
6.2	282.3		4	4	5	5	6	7	7	7	9●	10●	
7.59	230.6		4	4	5	5	6	7	7	7	9●	10●	
9.3	188.2		4	5	5	6	7	7	7	9●	10●	10●	
11.39	153.6		4	5	6	7	7	7	9●	9●	10●	11●	
13.95	125.4		5	6	6	7	7	9	9	10●	10●	11●	
17.09	102.4		5	6	7	7	7	9	10	10●	11●	11●	
20.93	83.6		6	7	7	7	9	9	10●	10●	11●	12●	
25.63	68.3		6	7	7	9	9	10	10●	11●	12●	-	
31.39	55.8	TRIPLE	7	7	9	9	9	10	11	11	12●	-	
38.44	45.5		7	9	9	9	10	10	11	11	12	-	
47.08	37.2		7	9	9	10	10	11	12	-	-	-	
57.67	30.4		9	9	10	10	11	12	-	-	-	-	
70.62	24.8		9	10	10	11	11	-	-	-	-	-	
86.5	20.2		9	10	10	11	12	-	-	-	-	-	
105.9	16.5		10	10	11	12	-	-	-	-	-	-	
129.7	13.5		10	11	12	-	-	-	-	-	-	-	
158.9	11		11	12	-	-	-	-	-	-	-	-	
194.6	9		11	-	-	-	-	-	-	-	-	-	

■ Some reducers selections are oversized to accommodate scoop mounting of motor on reducers
 ● Cooling fan required + TEFC-XE Frame, Energy Efficient Motors
 Note: The suggested mounting for motors weighing 700 pounds or more is the MAXUM HD baseplate. See page G3-38

■ Sizes 1-3 discontinued. Remaining stock may be available

FEATURES/BENEFITS PAGE G3-3	NOMENCLATURE PAGE G3-6	SELECTION/DIMENSIONS PAGE G3-23	RELATED PRODUCTS PAGE G3-55
--------------------------------	---------------------------	------------------------------------	--------------------------------



MAXUM Concentric Reducer Size 1

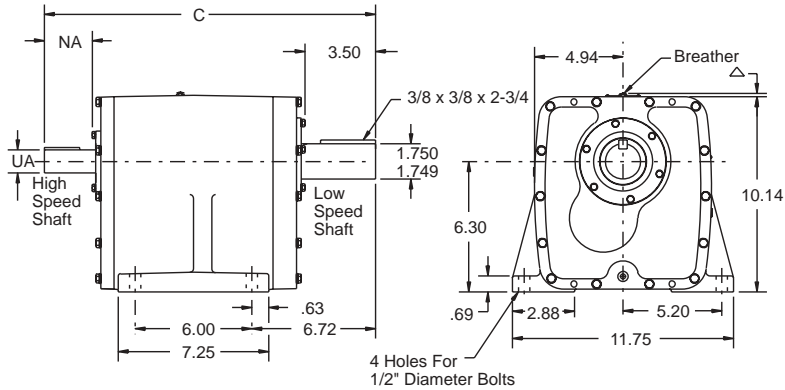

△ 1-1/2" will clear breather on all size units.

Size 1	C	NA	UA	Key	Weight (lbs.)
Double Reduction	18.67	3.05	1.375/1.374	5/16 x 5/16 x 2-3/16	125
Triple Reduction	18.67	3.05	1.375/1.374	5/16 x 5/16 x 2-3/16	135

Size 1 Part Numbers

	Nominal Ratio	Separate Reducer †
D O U B L E	DCR1- 2.25	299000
	DCR1- 2.75	299001
	DCR1- 3.37	299002
	DCR1- 4.13	299003
	DCR1- 5.06	299004
	DCR1- 6.2	299005
	DCR1- 7.59	299006
	DCR1- 9.3	299007
	DCR1- 11.9	299008
	DCR1- 14.95	299009
	DCR1- 17.09	299010
	DCR1- 20.93	299011
DCR1- 25.63	299012	
T R I P L E	TCR1- 31.39	299013
	TCR1- 38.44	299014
	TCR1- 47.08	299015
	TCR1- 57.67	299016
	TCR1- 70.62	299017
	TCR1- 86.5	299018
	TCR1- 105.9	299019
	TCR1- 129.7	299020
	TCR1- 158.9	299021
	TCR1- 194.6	299022

† Suitable for backstop mounting
See page G3-36 for dimensions

Size 1 Scoop Part Numbers ■

	NEMA A-C Motor Frame	Scoop Package	Scoop Package	Scoop Package
		PARA-FLEX Cplg.	GRID-LIGN Cplg.	Weights PARA-GRID
Double	143T, 145T	DCS01140P	DCS01140G	60/57
	182T, 185T	DCS01180P	DCS01180G	60/57
	213T, 215T	DCS01210P	DCS01210G	60/57
Triple	143T, 145T	TCS01140P	TCS01140G	60/57
	182T, 185T	TCS01180P	TCS01180G	60/57

* Scoop package includes scoop, coupling, coupling guard, and mounting hardware.

Size 1 Accessories* ■

Description	Part Number	Weight (lbs)
AUXILIARY SEAL KIT	299701	3
BACKSTOP (2.25-194.6)	299375	28
SLIDE BASE	304627	45
TOP MOTOR MOUNT	299529	80

* Baseplates refer to pages G3-38 and G3-39.

■ Refer to Table 12, page G3-34 for compatibility of various combinations of reducers and accessories.

■ Sizes 1-3 discontinued. Remaining stock may be available

FEATURES/BENEFITS PAGE G3-3	NOMENCLATURE PAGE G3-6	EASY SELECTION PAGE G3-7	RELATED PRODUCTS PAGE G3-55
--------------------------------	---------------------------	-----------------------------	--------------------------------



SELECTION/DIMENSIONS

MAXUM Concentric Reducer Size 2

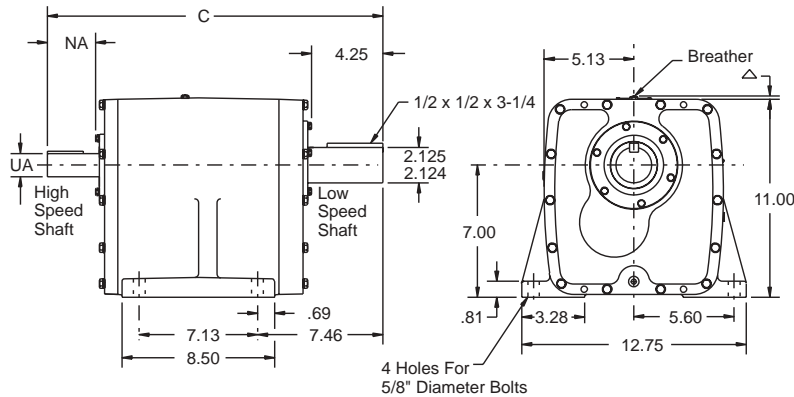

△ 1-1/2" will clear breather on all size units.

Size 2	C	NA	UA	Key	Weight (lbs.)
Double Reduction	20.63	3.05	1.375/1.374	5/16 x 5/16 x 2-3/16	160
Triple Reduction	20.63	3.05	1.375/1.374	5/16 x 5/16 x 2-3/16	175

Size 2 Part Numbers

Nominal Ratio		Separate Reducer †
D O U B L E	DCR2- 2.25	299023
	DCR2- 2.75	299024
	DCR2- 3.37	299025
	DCR2- 4.13	299026
	DCR2- 5.06	299027
	DCR2- 6.2	299028
	DCR2- 7.59	299029
	DCR2- 9.3	299030
	DCR2- 11.39	299031
	DCR2- 13.95	299032
	DCR2- 17.09	299033
	DCR2- 20.93	299034
DCR2- 25.63	299035	
T R I P L E	TCR2- 31.39	299036
	TCR2- 38.44	299037
	TCR2- 47.08	299038
	TCR2- 57.67	299039
	TCR2- 70.62	299040
	TCR2- 86.5	299041
	TCR2- 105.9	299042
	TCR2- 129.7	299043
TCR2- 158.9	299044	
TCR2- 194.6	299045	

† Suitable for backstop mounting
See page G3-36 for dimensions

Size 2 Scoop Part Numbers ■

NEMA A-C Motor Frame		Scoop Package PARA-FLX Cplg.	Scoop Package GRID-LIGN Cplg.	Scoop Package Weights PARA-GRID
D O U B L E	143T, 145T	DCS02140P	DCS02140G	101/98
	182T, 185T	DCS02180P	DCS02180G	101/98
	213T, 215T	DCS02210P	DCS02210G	101/98
	254T, 256T	DCS02250P	DCS02250G	116/110
T R I P L E	143T, 145T	TCS02140P	TCS02140G	101/98
	182T, 185T	TCS02180P	TCS02180G	101/98
	213T, 215T	TCS02210P	TCS02210G	101/98

* Scoop package includes scoop, coupling, coupling guard, and mounting hardware.

Size 2 Accessories* ■

Description	Part Number	Weight (lbs)
AUXILIARY SEAL KIT	299699	3
BACKSTOP (2.25-194.6)	299375	28
SLIDE BASE	304628	48
TOP MOTOR MOUNT	299529	80

* Baseplates refer to pages G3-38 and G3-39.

■ Refer to Table 12, page G3-34 for compatibility of various combinations of reducers and accessories.

■ Sizes 1-3 discontinued. Remaining stock may be available

FEATURES/BENEFITS PAGE G3-3	NOMENCLATURE PAGE G3-6	EASY SELECTION PAGE G3-7	RELATED PRODUCTS PAGE G3-55
--------------------------------	---------------------------	-----------------------------	--------------------------------



MAXUM Concentric Reducer Size 3

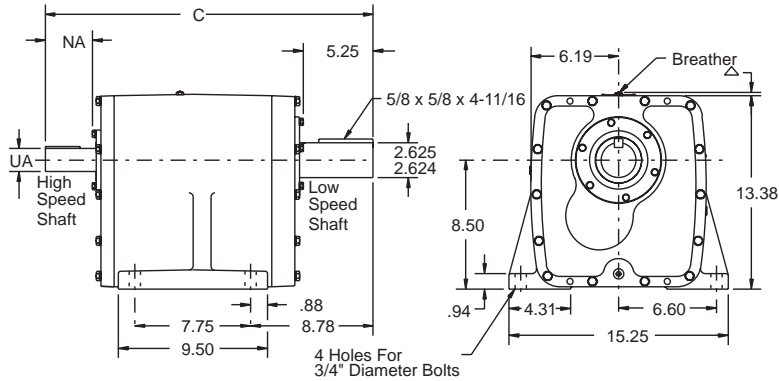

△ 1-1/2" will clear breather on all size units.

Size 3	C	NA	NA (with fan)	UA	Key	Weight (lbs.)
Double Reduction	23.08	3.50	1.78	1.625/1.624	3/8 x 3/8 x 2-1/2	230
Triple Reduction	23.08	3.50	-	1.625/1.624	3/8 x 3/8 x 2-1/2	250

Size 3 Part Numbers

	Nominal Ratio	Separate Reducer †
D O U B L E	DCR3- 2.25	299046
	DCR3- 2.75	299047
	DCR3- 3.37	299048
	DCR3- 4.13	299049
	DCR3- 5.06	299050
	DCR3- 6.2	299051
	DCR3- 7.59	299052
	DCR3- 9.3	299053
	DCR3- 11.39	299054
	DCR3- 13.95	299055
	DCR3- 17.09	299056
	DCR3- 20.93	299057
	DCR3- 25.63	299058
T R I P L E	TCR3- 31.39	299059
	TCR3- 38.44	299060
	TCR3- 47.08	299061
	TCR3- 57.67	299062
	TCR3- 70.62	299063
	TCR3- 86.5	299064
	TCR3- 105.9	299065
	TCR3- 129.7	299066
TCR3- 158.9	299067	
TCR3- 194.6	299068	

† Suitable for backstop mounting
See page G3-36 for dimensions

Size 3 Scoop Part Numbers ■

	NEMA A-C Motor Frame	Scoop Package	Scoop Package	Scoop Package
		PARA-FLEX Cplg.	GRID-LIGN Cplg.	Weights PARA/GRID
D O U B L E	143T, 145T	DCS03140P	DCS03140G	116/114
	182T, 185T	DCS03180P	DCS03180G	120/114
	213T, 215T	DCS03210P	DCS03210G	120/114
	254T, 256T	DCS03250P	DCS03250G	125/119
	284T, 286T	DCS03280P	DCS03280G	149/140
	T R I P L E	143T, 145T	TCS03140P	TCS03140G
182T, 185T		TCS03180P	TCS03180G	120/114
213T, 215T		TCS03210P	TCS03210G	120/114
254T, 256T		TCS03250P	TCS03250G	125/119

* Scoop package includes scoop, coupling, coupling guard, and mounting hardware.

Size 3 Accessories* ■

Description	Part Number	Weight (lbs)
AUXILIARY SEAL KIT	300305	3
BACKSTOP (7.59-194.6)+	299375	28
COOLING FAN	299519	8
SLIDE BASE	304629	54
TOP MOTOR MOUNT	299530	107

* Baseplates refer to pages G3-38 and G3-39.

■ Refer to Table 12, page G3-34 for compatibility of various combinations of reducers and accessories.

+ For backstops on ratios not listed, consult DODGE

■ Sizes 1-3 discontinued. Remaining stock may be available

FEATURES/BENEFITS PAGE G3-3	NOMENCLATURE PAGE G3-6	EASY SELECTION PAGE G3-7	RELATED PRODUCTS PAGE G3-55
--------------------------------	---------------------------	-----------------------------	--------------------------------

SELECTION/DIMENSIONS



MAXUM Concentric Reducer Size 4

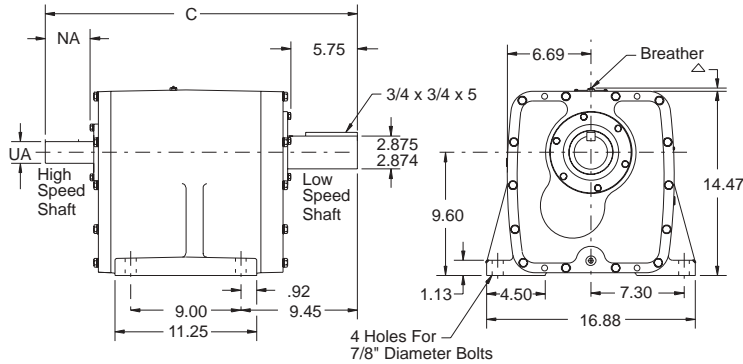

△ 1-1/2" will clear breather on all size units.

Size 4	C	NA	NA (with fan)	UA	Key	Weight (lbs.)
Double Reduction	25.47	3.50	1.78	1.625/1.624	3/8 x 3/8 x 2-1/2	330
Triple Reduction	25.47	3.50	-	1.625/1.624	3/8 x 3/8 x 2-1/2	330

Size 4 Part Numbers

Nominal Ratio		Separate Reducer †
D O U B L E	DCR4- 2.25	299069
	DCR4- 2.75	299070
	DCR4- 3.37	299071
	DCR4- 4.13	299072
	DCR4- 5.06	299073
	DCR4- 6.2	299074
	DCR4- 7.59	299075
	DCR4- 9.3	299076
	DCR4- 11.39	299077
	DCR4- 13.95	299078
	DCR4- 17.09	299079
	DCR4- 20.93	299080
	DCR4- 25.63	299081
T R I P L E	TCR4- 31.39	299082
	TCR4- 38.44	299083
	TCR4- 47.08	299084
	TCR4- 57.67	299085
	TCR4- 70.62	299086
	TCR4- 86.5	299087
	TCR4- 105.9	299088
	TCR4- 129.7	299089
TCR4- 158.9	299090	
TCR4- 194.6	299091	

† Suitable for backstop mounting
See page G3-36 for dimensions

Size 4 Scoop Part Numbers ■

NEMA AC-Motor Frame	Scoop Package PARA-FLEX Cplg.	Scoop Package GRID-LIGN Cplg.	Scoop Package Weights	
			PARA/GRID	
DOUBLE	143T, 145T	DCS04140P	DCS04140G	134/132
	182T, 184T	DCS04180P	DCS04180G	138/132
	213T, 215T	DCS04210P	DCS04210G	138/132
	254T, 256T	DCS04250P	DCS04250G	143/137
	284T, 286T	DCS04280P	DCS04280G	167/158
	324T, 326T	DCS04320P	DCS04320G	174/170
TRIPLE	143T, 145T	TCS04140P	TCS04140G	134/132
	182T, 184T	TCS04180P	TCS04180G	138/132
	213T, 215T	TCS04210P	TCS04210G	138/132
	254T, 256T	TCS04250P	TCS04250G	143/137
	284T, 286T	TCS04280P	TCS04280G	167/158

* Scoop package includes scoop, coupling, coupling guard, and mounting hardware.

Size 4 Accessories* ■

Description	Part Number	Weight (lbs)
AUXILIARY SEAL KIT	300302	3
BACKSTOP (13.95-194.6)+	299375	28
COOLING FAN	299520	6
SLIDE BASE	304630	95
TOP MOTOR MOUNT	299530	107

* Baseplates refer to pages G3-38 and G3-39.

■ Refer to Table 12, page G3-34 for compatibility of various combinations of reducers and accessories.

+ For backstops on ratios not listed, consult DODGE

FEATURES/BENEFITS PAGE G3-3	NOMENCLATURE PAGE G3-6	EASY SELECTION PAGE G3-7	RELATED PRODUCTS PAGE G3-55
--------------------------------	---------------------------	-----------------------------	--------------------------------



MAXUM Concentric Reducer Size 5

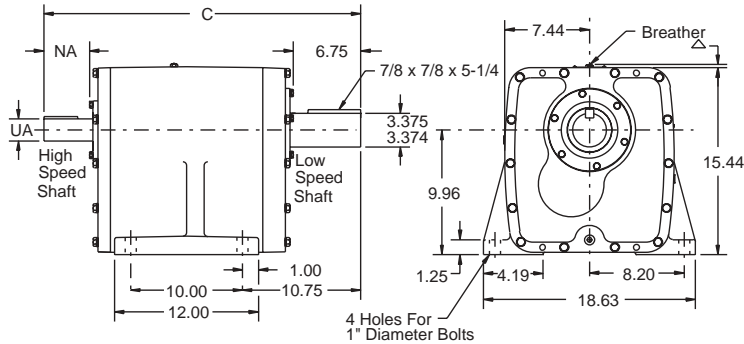

△ 1-1/2" will clear breather on all size units.

Size 5	C	NA	NA (with fan)	UA	Key	Weight (lbs.)
Double Reduction	29.14	4.51	2.69	2.125/2.124	1/2 x 1/2 x 3-3/8	420
Triple Reduction	28.05	3.42	-	1.625/1.624	3/8 x 3/8 x 2-1/2	450

Size 5 Part Numbers

	Nominal Ratio	Separate Reducer †
D O U B L E	DCR5- 2.25	299092
	DCR5- 2.75	299093
	DCR5- 3.37	299094
	DCR5- 4.13	299095
	DCR5- 5.06	299096
	DCR5- 6.2	299097
	DCR5- 7.59	299098
	DCR5- 9.3	299099
	DCR5- 11.39	299100
	DCR5- 13.95	299101
	DCR5- 17.09	299102
	DCR5- 20.93	299103
DCR5- 25.63	299104	
T R I P L E	TCR5- 31.39	299105
	TCR5- 38.44	299106
	TCR5- 47.08	299107
	TCR5- 57.67	299108
	TCR5- 70.62	299109
	TCR5- 86.5	299110
	TCR5- 105.9	299111
	TCR5- 129.7	299112
TCR5- 158.9	299113	
TCR5- 194.6	299114	

† Suitable for backstop mounting
See page G3-36 for dimensions

Size 5 Scoop Part Numbers ■

NEMA AC-Motor Frame		Scoop Package PARA-FLEX Cplg.	Scoop Package GRID-LIGN Cplg.	Scoop Package Weights PARA/GRID
DOUBLE	213T, 215T	DCS05210P	DCS05210G	187/183
	254T, 256T	DCS05250P	DCS05250G	187/183
	284T, 286T	DCS05280P	DCS05280G	195/191
	324T, 326T	DCS05320P	DCS05320G	195/191
	364T, 365T	DCS05360P	DCS05360G	204/197
	143T, 145T	TCS05140P	TCS05140G	170/168
TRIPLE	182T, 184T	TCS05180P	TCS05180G	174/168
	213T, 215T	TCS05210P	TCS05210G	174/168
	254T, 256T	TCS05250P	TCS05250G	179/173
	284T, 286T	TCS05280P	TCS05280G	187/177

* Scoop package includes scoop, coupling, coupling guard, and mounting hardware.

Size 5 Accessories* ■

Description	Part Number	Weight (lbs)
AUXILIARY SEALS (2.25-25.63)	300906	4
AUXILIARY SEALS (31.39-194.6)	300903	4
BACKSTOP (9.30-194.6)+	299377	28
COOLING FAN	299521	9
HEAT EXCHANGER	014148	55
SLIDE BASE	304631	100
TOP MOTOR MOUNT	299531	149

* Baseplates refer to pages G3-38 and G3-39.

■ Refer to Table 12, page G3-34 for compatibility of various combinations of reducers and accessories.

+ For backstops on ratios not listed, consult DODGE

FEATURES/BENEFITS PAGE G3-3	NOMENCLATURE PAGE G3-6	EASY SELECTION PAGE G3-7	RELATED PRODUCTS PAGE G3-55
--------------------------------	---------------------------	-----------------------------	--------------------------------

SELECTION/DIMENSIONS



MAXUM Concentric Reducer Size 6

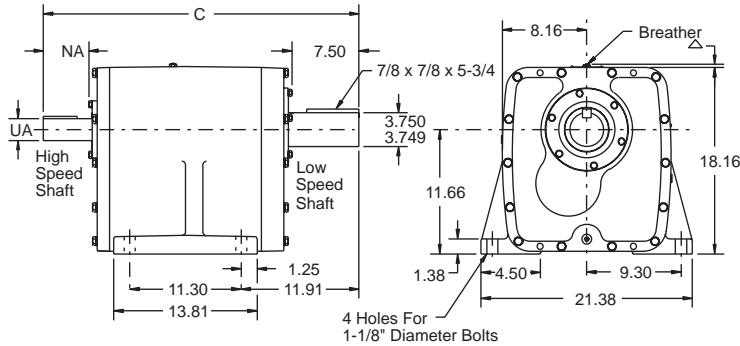

△ 1-1/2" will clear breather on all size units.

Size 6	C	NA	NA (with fan)	UA	Key	Weight (lbs.)
Double Reduction	31.44	4.51	2.69	2.125/2.124	1/2 x 1/2 x 3-3/8	600
Triple Reduction	30.36	3.42	-	1.625/1.624	3/8 x 3/8 x 2-1/2	630

Size 6 Part Numbers

	Nominal Ratio	Separate Reducer †
D O U B L E	DCR6- 2.25	299115
	DCR6- 2.75	299116
	DCR6- 3.37	299117
	DCR6- 4.13	299118
	DCR6- 5.06	299119
	DCR6- 6.2	299120
	DCR6- 7.59	299121
	DCR6- 9.3	299122
	DCR6- 11.39	299123
	DCR6- 13.95	299124
	DCR6- 17.09	299125
	DCR6- 20.93	299126
DCR6- 25.63	299127	
T R I P L E	TCR6- 31.39	299128
	TCR6- 38.44	299129
	TCR6- 47.08	299130
	TCR6- 57.67	299131
	TCR6- 70.62	299132
	TCR6- 86.5	299133
	TCR6- 105.9	299134
	TCR6- 129.7	299135
TCR6- 158.9	299136	
TCR6- 194.6	299137	

† Suitable for backstop mounting
See page G3-36 for dimensions

Size 6 Scoop Numbers ■

NEMA A-C Motor Frame		Scoop Package PARA-FLEX Cplg	Scoop Package GRID-LIGN Cplg	Scoop Package Weights PARA/GRID
DOUBLE	213T, 215T	DCS06210P	DCS06210G	198/200
	254T, 256T	DCS06250P	DCS06250G	198/200
	284T, 286T	DCS06280P	DCS06280G	206/208
	324T, 326T	DCS06320P	DCS06320G	206/208
	364T, 365T	DCS06360P	DCS06360G	215/208
TRIPLE	182T, 184T	TCS06180P	TCS06180G	185/179
	213T, 215T	TCS06210P	TCS06210G	185/179
	254T, 256T	TCS06250P	TCS06250G	190/184
	284T, 286T	TCS06280P	TCS06280G	197/188
	324T, 326T	TCS06320P	TCS06320G	204/200
364T, 365T	TCS06360P	TCS06360G	218/211	

* Scoop package includes scoop, coupling, coupling guard, and mounting hardware.

Size 6 Accessories* ■

Description	Part Number	Weight (lbs)
AUXILIARY SEALS (2.25-25.63)	300904	5
AUXILIARY SEALS (31.39-194.6)	301204	5
BACKSTOP (13.95-194.6)+	299377	28
COOLING FAN	299522	10
HEAT EXCHANGER	014148	55
SLIDE BASE	304632	112
TOP MOTOR MOUNT	299531	149

* Baseplates refer to pages G3-38 and G3-39.

■ Refer to Table 12, page G3-34 for compatibility of various combinations of reducers and accessories.

+ For backstops on ratios not listed, consult DODGE

FEATURES/BENEFITS PAGE G3-3	NOMENCLATURE PAGE G3-6	EASY SELECTION PAGE G3-7	RELATED PRODUCTS PAGE G3-55
--------------------------------	---------------------------	-----------------------------	--------------------------------



MAXUM Concentric Reducer Size 7

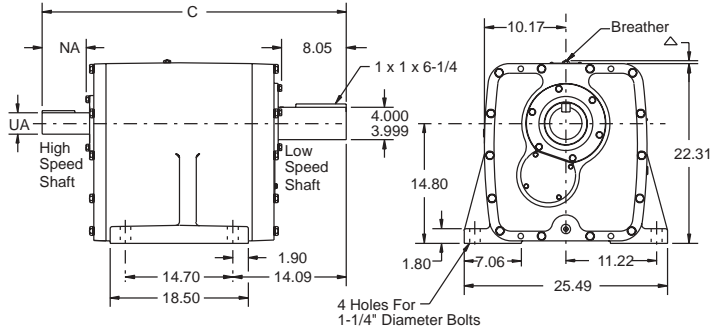

△ 1-1/2" will clear breather on all size units.

Size 7	C	NA	NA (with fan)	UA	Key	Weight (lbs.)
Double Reduction	39.06	5.41	3.75	2.625/2.624	5/8 x 5/8 x 4-1/4	1180
Triple Reduction	37.64	3.77	-	1.875/1.874	1/2 x 1/2 x 2-1/2	1220

Size 7 Part Numbers

Nominal Ratio		Separate Reducer	Backstop (1) (2) Reducer
D O U B L E	DCR7- 5.06	299138	303100
	DCR7- 6.2	299139	303101
	DCR7- 7.59	299140	303102
	DCR7- 9.3	299141	303103
	DCR7- 11.39	299142	303104
	DCR7- 13.95	299143	303105
	DCR7- 17.09	299144	303106
	DCR7- 20.93	299145	303107
T R I P L E	DCR7- 25.63	299146	303108
	TCR7- 31.39	299147	303109
	TCR7- 38.44	299148	303110
	TCR7- 47.08	299149	303111
	TCR7- 57.67	299150	303112
	TCR7- 70.62	299151	303113
	TCR7- 86.5	299152	303114
	TCR7- 105.9	299153	303115
	TCR7- 129.7	299154	303116
	TCR7- 158.9	299155	303117
TCR7- 194.6	299156	303118	

- (1) Backstop dimensions page G3-36.
 (2) Reducer includes extended high speed shaft for external backstop. External backstop assembly not included, see accessories.

Size 7 Scoop Part Number ■

NEMA A-C Motor Frame		Scoop Package PARA-FLEX Cplg.	Scoop Package GRID-LIGN Cplg.	Scoop Package Weights PARA/GRID
D O U B L E	254T, 256T	DCS07250P	DCS07250G	253/246
	284T, 286T	DCS07280P	DCS07280G	253/246
	324T, 326T	DCS07320P	DCS07320G	253/246
	364T, 365T	DCS07360P	DCS07360G	253/246
	404T, 405T	DCS07400P	DCS07400G	356/321
	444T, 445T	DCS07440P	DCS07440G	436/341
T R I P L E	213T, 215T	TCS07210P	TCS07210G	230/221
	254T, 256T	TCS07250P	TCS07250G	230/221
	284T, 286T	TCS07280P	TCS07280G	243/234
	324T, 326T	TCS07320P	TCS07320G	243/234
	364T, 365T	TCS07360P	TCS07360G	252/245

* Scoop package includes scoop, coupling, coupling guard, and mounting hardware.

Size 7 Accessories* ■

Description	Part Number	Weight (lbs)
AUXILIARY SEAL KIT	301504	6
BACKSTOP (5.06-25.63)	299379	25
BACKSTOP (31.39-194.6)	299380	16
COOLING FAN	299523	16
HEAT EXCHANGER	014148	55
SLIDE BASE	304633	245
TOP MOTOR MOUNT	299532	257

* Baseplates refer to pages G3-38 and G3-39.

■ Refer to Table 12, page G3-34 for compatibility of various combinations of reducers and accessories.

+ For backstops on ratios not listed, consult DODGE

FEATURES/BENEFITS PAGE G3-3	NOMENCLATURE PAGE G3-6	EASY SELECTION PAGE G3-7	RELATED PRODUCTS PAGE G3-55
--------------------------------	---------------------------	-----------------------------	--------------------------------

SELECTION/DIMENSIONS



MAXUM Concentric Reducer Size 9

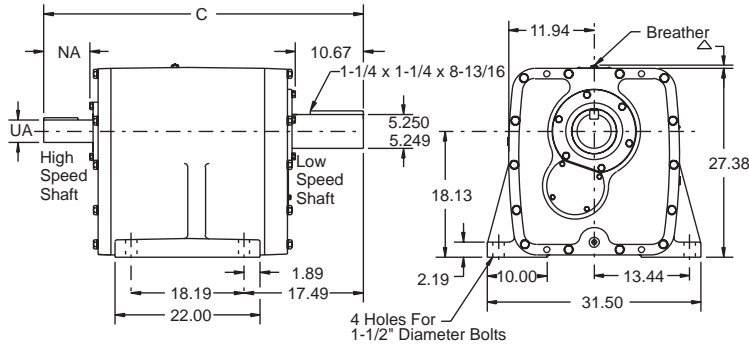

△ 1-1/2" will clear breather on all size units.

	Size 9	C	NA	NA (with fan)	UA	Key	Weight (lbs.)
	Double Reduction	47.39	6.25	3.75	3.000/2.999	3/4 x 3/4 x 4-7/8	2160
	Triple Reduction	45.70	4.23	-	2.125/2.124	1/2 x 1/2 x 3-3/8	2240

Size 9 Part Numbers

Nominal Ratio		Separate Reducer	Backstop (1) (2) Reducer
D O U B L E	DCR9- 5.06	299176	303138
	DCR9- 6.2	299177	303139
	DCR9- 7.59	299178	303140
	DCR9- 9.3	299179	303141
	DCR9- 11.39	299180	303142
	DCR9- 13.95	299181	303143
	DCR9- 17.09	299182	303144
	DCR9- 20.93	299183	303145
T R I P L E	DCR9- 25.63	299184	303146
	TCR9- 31.39	299185	303147
	TCR9- 38.44	299186	303148
	TCR9- 47.08	299187	303149
	TCR9- 57.67	299188	303150
	TCR9- 70.62	299189	303151
	TCR9- 86.5	299190	303152
	TCR9- 105.9	299191	303153
P L E	TCR9- 129.7	299192	303154
	TCR9- 158.9	299193	303155
	TCR9- 194.6	299194	303156

(1) Backstop dimensions page G3-36.

(2) Reducer includes extended high speed shaft for external backstop. External backstop assembly not included, see accessories.

Size 9 Scoop Part Numbers ■

NEMA A-C Motor Frame		Scoop Package PARA-FLEX Cplg	Scoop Package GRID-LIGN Cplg	Scoop Pkg. Weights PARA/GRID
DOUBLE	324T, 326T	DCS09320P	DCS09320G	362/327
	364T, 365T	DCS09360P	DCS09360G	363/327
	404T, 405T	DCS09400P	DCS09400G	418/382
	444T, 445T	DCS09440P	DCS09440G	500/405
TRIPLE	254T, 256T	TCS09250P	TCS09250G	294/290
	284T, 286T	TCS09280P	TCS09280G	294/290
	324T, 326T	TCS09320P	TCS09320G	305/301
	364T, 365T	TCS09360P	TCS09360G	314/307
	404T, 405T	TCS09400P	TCS09400G	415/380
	444T, 445T	TCS09440P	TCS09440G	498/403

* Scoop package includes scoop, coupling, coupling guard, and mounting hardware.

Size 9 Accessories* ■

Description	Part Number	Weight (lbs)
AUXILIARY SEAL KIT	302104	8
BACKSTOP (5.06-11.39)	299384	55
BACKSTOP (13.95-25.63)	299385	31
BACKSTOP (31.39-194.6)	299386	25
COOLING FAN	299525	20
HEAT EXCHANGER	014148	55
SLIDE BASE	304635	300
TOP MOTOR MOUNT	299534	278

* Baseplates refer to pages G3-38 and G3-39.

■ Refer to Table 12, page G3-34 for compatibility of various combinations of reducers and accessories.

FEATURES/BENEFITS PAGE G3-3	NOMENCLATURE PAGE G3-6	EASY SELECTION PAGE G3-7	RELATED PRODUCTS PAGE G3-55
--------------------------------	---------------------------	-----------------------------	--------------------------------



MAXUM Concentric Reducer Size 10

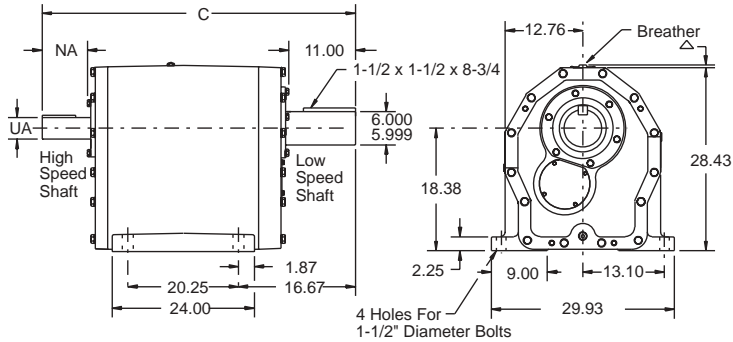

△ 1-1/2" will clear breather on all size units.

Size 10	C	NA	NA (with fan)	UA	Key	Weight (lbs.)
Double Reduction	48.20	6.31	3.75	3.500/3.499	7/8 x 7/8 x 4-7/8	2420
Triple (31.39-70.62)	48.22	5.90	3.75	2.375/2.374	5/8 x 5/8 x 4-15/16	2550
Triple (86.50-194.6)	47.09	4.78	2.64	2.375/2.374	5/8 x 5/8 x 3-3/4	2550

Size 10 Part Numbers

	Nominal Ratio	Separate Reducer	Backstop (1) (2) Reducer
D O U B L E	DCR10- 5.06	299195	303157
	DCR10- 6.2	299196	303158
	DCR10- 7.59	299197	303159
	DCR10- 9.3	299198	303160
	DCR10- 11.39	299199	303161
	DCR10- 13.95	299200	303162
	DCR10- 17.09	299201	303163
	DCR10- 20.93	299202	303164
	DCR10- 25.63	299203	303165
T R I P L E	TCR10- 31.39	299204	303166
	TCR10- 38.44	299205	303167
	TCR10- 47.08	299206	303168
	TCR10- 57.67	299207	303169
	TCR10- 70.62	299208	303170
	TCR10- 86.5	299209	303171
	TCR10- 105.9	299210	303172
	TCR10- 129.7	299211	303173
	TCR10- 158.9	299212	303174
TCR10- 194.6	299213	303175	

(1) Backstop dimensions page G3-36.

(2) Reducer includes extended high speed shaft for external backstop. External backstop assembly not included, see accessories.

Size 10 Scoop Part Numbers ■

	NEMA A-C Motor Frame	Scoop Package PARA-FLEX Cplg.	Scoop Package GRID-LIGN Cplg.	Scoop Package Weights GRID-LIGN
D O U B L E	364T, 365T	DCS10360P	DCS10360G	467/372
	404T, 405T	DCS10400P	DCS10400G	509/414
	444T, 445T	DCS10440P	DCS10440G	518/423
T R I P L E	254T, 256T	TCS10250P	TCS10250G	317/310
	284T, 286T	TCS10280P	TCS10280G	317/310
	324T, 326T	TCS10320P	TCS10320G	336/330
	364T, 365T	TCS10360P	TCS10360G	336/330
	404T, 405T	TCS10400P	TCS10400G	432/397
	444T, 445T	TCS10440P	TCS10440G	518/423

* Scoop package includes scoop, coupling, coupling guard, and mounting hardware.

Size 10 Accessories* ■

Description	Part Number	Weight (lbs)
AUXILIARY SEAL KIT	302408	9
BACKSTOP (5.06-11.39)	299387	57
BACKSTOP (13.95-70.62)	299388	33
BACKSTOP (86.50-194.6)	299389	27
COOLING FAN (5.06-25.63)	299526	23
COOLING FAN (31.39-194.6)	299842	23
HEAT EXCHANGER	014148	55
SLIDE BASE	304636	370
TOP MOTOR MOUNT	299535	283

* Baseplates refer to pages G3-38 and G3-39.

■ Refer to Table 12, page G3-34 for compatibility of various combinations of reducers and accessories.

FEATURES/BENEFITS PAGE G3-3	NOMENCLATURE PAGE G3-6	EASY SELECTION PAGE G3-7	RELATED PRODUCTS PAGE G3-55
--------------------------------	---------------------------	-----------------------------	--------------------------------

SELECTION/DIMENSIONS



MAXUM Concentric Reducer Size 11

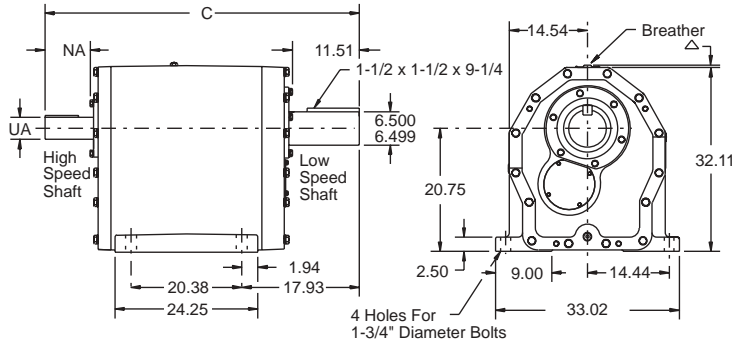

△ 1-1/2" will clear breather on all size units.

Size 11	C	NA	NA (with fan)	UA	Key	Weight (lbs.)
Double Reduction	49.84	5.33	3.75	3.750/3.749	7/8 x 7/8 x 4-1/2	3240
Triple (31.39-70.62)	49.84	5.37	3.75	2.375/2.374	5/8 x 5/8 x 4-15/16	3400
Triple (86.50-194.6)	48.65	4.18	2.53	2.375/2.374	5/8 x 5/8 x 3-3/4	3400

Size 11 Part Numbers

	Nominal Ratio	Separate Reducer	Backstop (1) (2) Reducer
D O U B L E	DCR11- 5.06	299214	303176
	DCR11- 6.2	299215	303177
	DCR11- 7.59	299216	303178
	DCR11- 9.3	299217	303179
	DCR11- 11.39	299218	303180
	DCR11- 13.95	299219	303181
	DCR11- 17.09	299220	303182
	DCR11- 20.93	299221	303183
	DCR11- 25.63	299222	303184
T R I P L E	TCR11- 31.39	299223	303185
	TCR11- 38.44	299224	303186
	TCR11- 47.08	299225	303187
	TCR11- 57.67	299226	303188
	TCR11- 70.62	299227	303189
	TCR11- 86.5	299228	303190
	TCR11- 105.9	299229	303191
	TCR11- 129.7	299230	303192
	TCR11- 158.9	299231	303193
TCR11- 194.6	299232	303194	

- (1) Backstop dimensions page G3-36.
 (2) Reducer includes extended high speed shaft for external backstop. External backstop assembly not included, see accessories.

Size 11 Scoop Part Numbers ■

NEMA A-C Motor Frame		Scoop Package PARA-FLEX Cplg.	Scoop Package GRID-LIGN Cplg.	Scoop Package Weights PARA-GRID
DOUBLE	364T, 365T	DCS11360P	DCS11360G	490/395
	404T, 405T	DCS11400P	DCS11400G	537/442
	444T, 445T	DCS11440P	DCS11440G	550/455
TRIPLE	284T, 286T	TCS11280P	TCS11280G	364/357
	324T, 326T	TCS11320P	TCS11320G	364/357
	364T, 365T	TCS11360P	TCS11360G	364/357
	404T, 405T	TCS11400P	TCS11400G	459/423
	444T, 445T	TCS11440P	TCS11440G	544/449

* Scoop package includes scoop, coupling, coupling guard, and mounting hardware.

Size 11 Accessories* ■

Description	Part Number	Weight (lbs)
AUXILIARY SEAL KIT	302711	11
BACKSTOP (5.06-11.39)	299390	101
BACKSTOP (13.95-25.63)	299391	59
BACKSTOP (31.39-70.62)	299392	36
BACKSTOP (86.50-194.6)	299845	30
COOLING FAN (5.06-25.63)	299527	27
COOLING FAN (31.39-194.6)	299843	27
HEAT EXCHANGER	014148	55
SLIDE BASE	304637	380
TOP MOTOR MOUNT	299536	289

* Baseplates refer to pages G3-38 and G3-39.

■ Refer to Table 12, page G3-34 for compatibility of various combinations of reducers and accessories.

FEATURES/BENEFITS PAGE G3-3	NOMENCLATURE PAGE G3-6	EASY SELECTION PAGE G3-7	RELATED PRODUCTS PAGE G3-55
--------------------------------	---------------------------	-----------------------------	--------------------------------



MAXUM Concentric Reducer Size 12

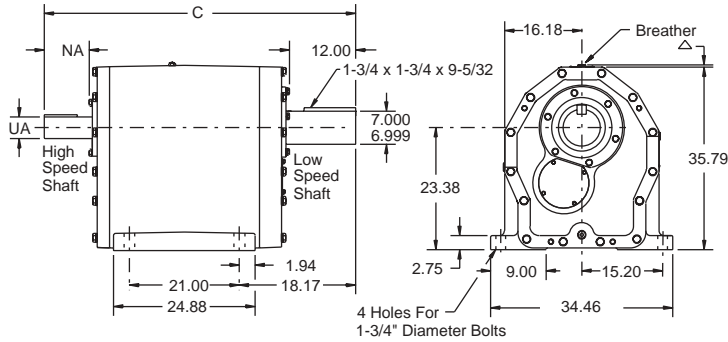

△ 1-1/2" will clear breather on all size units.

Size 12	C	NA	NA (with fan)	UA	Key	Weight (lbs.)
Double Reduction	50.41	5.33	3.75	3.750/3.749	7/8 x 7/8 x 4-1/2	4000
Triple (31.39-70.62)	50.41	5.37	3.75	2.375/2.374	5/8 x 5/8 x 4-15/16	4200
Triple (86.50-194.6)	49.22	4.18	2.56	2.375/2.374	5/8 x 5/8 x 3-3/4	4200

Size 12 Part Numbers

	Nominal Ratio	Separate Reducer	Backstop (1) (2) Reducer
D O U B L E	DCR12- 5.06	299233	-
	DCR12- 6.2	299234	303196
	DCR12- 7.59	299235	303197
	DCR12- 9.3	299236	303198
	DCR12- 11.39	299237	303199
	DCR12- 13.95	299238	303200
	DCR12- 17.09	299239	303201
	DCR12- 20.93	299240	303202
	DCR12- 25.63	299241	303203
T R I P L E	TCR12- 31.39	299242	303204
	TCR12- 38.44	299243	303205
	TCR12- 47.08	299244	303206
	TCR12- 57.67	299245	303207
	TCR12- 70.62	299246	303208
	TCR12- 86.5	299247	303209
	TCR12- 105.9	299248	303210
	TCR12- 129.7	299249	303211
	TCR12- 158.9	299250	303212
	TCR12- 194.6	299251	303213

(1) Backstop dimensions page G3-36.

(2) Reducer includes extended high speed shaft for external backstop. External backstop assembly not included, see accessories.

Size 12 Scoop Part Numbers ■

	NEMA A-C Motor Frame	Scoop Package PARA-FLEX Cplg.	Scoop Package GRID-LIGN Cplg.	Scoop Package Weights PARA-GRID
D O U B L E	364T, 365T	DCS12360P	DCS12360G	505/410
	404T, 405T	DCS12400P	DCS12400G	552/457
	444T, 445T	DCS12440P	DCS12440G	565/470
T R I P L E	284T, 286T	TCS12280P	TCS12280G	379/372
	324T, 326T	TCS12320P	TCS12320G	379/372
	364T, 365T	TCS12360P	TCS12360G	379/372
	404T, 405T	TCS12400P	TCS12400G	474/438
	444T, 445T	TCS12440P	TCS12440G	559/464

* Scoop package includes scoop, coupling, coupling guard, and mounting hardware.

Size 12 Accessories* ■

Description	Part Number	Weight (lbs)
AUXILIARY SEAL KIT	302713	11
BACKSTOP (6.20-11.39)	299393	103
BACKSTOP (13.95-25.63)	299394	61
BACKSTOP (31.39-70.62)	299395	38
BACKSTOP (86.50-194.6)	299846	32
COOLING FAN (5.06-25.63)	299528	31
COOLING FAN (31.39-194.6)	299844	31
HEAT EXCHANGER	014148	55
SLIDE BASE	304638	410
TOP MOTOR MOUNT	299537	301

* Baseplates refer to pages G3-38 and G3-39.

■ Refer to Table 12, page G3-34 for compatibility of various combinations of reducers and accessories.

FEATURES/BENEFITS PAGE G3-3	NOMENCLATURE PAGE G3-6	EASY SELECTION PAGE G3-7	RELATED PRODUCTS PAGE G3-55
--------------------------------	---------------------------	-----------------------------	--------------------------------

MODIFICATIONS/ ACCESSORIES



MAXUM Concentric Reducer

Table 12: Accessory Compatibility For Combinations Of
MAXUM Reducers And Accessories ▲

REDUCER		ACCESSORIES				
SIZE	CONFIGURATION	AUX. SEAL	BACK-STOP	COOLING-FAN	BS. & C.F.	SLIDE BASE
4	SEPARATE	YES	YES	YES	*	YES
	SCOOP MOUNT	YES	YES**	YES**	*	YES
	BASEPLATE	YES	YES	YES	*	YES*
	TOP MOUNT	YES	YES	*	*	YES

REDUCER		ACCESSORIES				
SIZE	CONFIGURATION	AUX. SEAL	BACK-STOP	COOLING-FAN	BS. & C.F.	SLIDE BASE
5	SEPARATE	YES	YES	YES 1	*	YES
	SCOOP MOUNT	YES	YES**	YES**1	*	YES
	BASEPLATE	YES	YES	YES 1	*	YES*
	TOP MOUNT	YES	YES	*	*	YES

REDUCER		ACCESSORIES				
SIZE	CONFIGURATION	AUX. SEAL	BACK-STOP	COOLING-FAN	BS. & C.F.	SLIDE BASE
6	SEPARATE	YES	YES	YES 1	*	YES
	SCOOP MOUNT	YES	YES**	YES**1	*	YES
	BASEPLATE	YES	YES	YES 1	*	YES*
	TOP MOUNT	YES	YES	*	*	YES

▲ Consult DODGE for combinations not listed

* Consult DODGE, made-to-order accessory combination

YES Stock accessory combination is compatible

** Non-stock coupling guard required

1 Standard cooling fan compatible only with these reducer sizes and ratios:
MAXUM 5 and 6, 2.25 - 25.63
Contact DODGE for other ratios."



MAXUM Concentric Reducer

Table 12: Accessory Compatibility For Combinations Of MAXUM Reducers And Accessories ▲

REDUCER		ACCESSORIES				
SIZE	CONFIGURATION	AUX. SEAL	BACK-STOP ◆ ●	COOL-ING-FAN	BS. & C.F. ◆	SLIDE BASE
7	SEPARATE	YES	YES	YES 1	*	YES
	SCOOP MOUNT	YES	YES**	YES** 1	*	YES
	BASEPLATE	YES	YES	YES 1	*	YES*
	TOP MOUNT	YES	*	*	*	YES

REDUCER		ACCESSORIES				
SIZE	CONFIGURATION	AUX. SEAL	BACK-STOP ◆ ●	COOL-ING-FAN	BS. & C.F. ◆	SLIDE BASE
11	SEPARATE	YES	YES	YES	YES 2	YES
	SCOOP MOUNT	YES	YES** 3	YES**	YES** 3 2	YES
	BASEPLATE	YES	YES	YES	YES 2	YES*
	TOP MOUNT	YES	*	*	*	YES

REDUCER		ACCESSORIES				
SIZE	CONFIGURATION	AUX. SEAL	BACK-STOP ◆ ●	COOL-ING-FAN	BS. & C.F. ◆	SLIDE BASE
9	SEPARATE	YES	YES	YES 1	YES 2	YES
	SCOOP MOUNT	YES	YES** 3	YES** 1	YES** 3 2	YES
	BASEPLATE	YES	YES	YES 1	YES 2	YES*
	TOP MOUNT	YES	*	*	*	YES

REDUCER		ACCESSORIES				
SIZE	CONFIGURATION	AUX. SEAL	BACK-STOP ◆ ●	COOL-ING-FAN	BS. & C.F. ◆	SLIDE BASE
12	SEPARATE	YES	YES	YES	YES 2	YES
	SCOOP MOUNT	YES	YES** 3	YES**	YES** 3 2	YES
	BASEPLATE	YES	YES	YES	YES 2	YES*
	TOP MOUNT	YES	*	*	*	YES

REDUCER		ACCESSORIES				
SIZE	CONFIGURATION	AUX. SEAL	BACK-STOP ◆ ●	COOL-ING-FAN	BS. & C.F. ◆	SLIDE BASE
10	SEPARATE	YES	YES	YES	YES 2	YES
	SCOOP MOUNT	YES	YES** 3	YES**	YES** 3 2	YES
	BASEPLATE	YES	YES	YES	YES 2	YES*
	TOP MOUNT	YES	*	*	*	YES

- ▲ Consult DODGE for combination not listed
- * Consult DODGE, made-to-order accessory combination
- YES Stock accessory combination is compatible
- ** Non-stock coupling guard required
- 1 Standard cooling fan compatible only with these reducer sizes and ratios:
MAXUM 7, 2.25 - 25.63
MAXUM 9, 5.06 - 25.63
Contact DODGE for other ratios.

- 2 Standard backstop and cooling fan compatible only with these reducer sizes and ratios:
MAXUM 8 and 9, 5.06 - 25.63
MAXUM 10, 5.06 - 70.62
MAXUM 11, 5.06 - 70.62
MAXUM 12, 6.20 - 70.62
Contact DODGE for other ratios.

- ◆ When using external backstops on sizes 7 through 12 reducers with scoops, see page G3-37 for UA and NA dimensions. Change out TL Bushing or Finish bore hub to fit smaller input shaft diameter of backstop reducer.

3 Non-Stock motor plate required for these reducers and scoop packages

RED. SIZE	RATIO	MTR FRAME SIZE	MTR. PLT. PART #
MAXUM 9	5.06 - 25.6	213T - 365T	299488
MAXUM 9	5.06 - 25.6	404T - 445T	299489
MAXUM 10 and 11	5.06 - 70.62	213T - 365T	299488
MAXUM 10 and 11	5.06 - 70.62	404T - 445T	299489
MAXUM 12	6.20 - 70.62	213T - 365T	299488
MAXUM 12	6.20 - 70.62	404T - 445T	299489

- Maximum 7 thru 12 Top Motor Mount applications with external backstops must be checked for over hung load.

FEATURES/BENEFITS PAGE G3-3	NOMENCLATURE PAGE G3-6	EASY SELECTION PAGE G3-7	RELATED PRODUCTS PAGE G3-55
--------------------------------	---------------------------	-----------------------------	--------------------------------

MODIFICATIONS/ ACCESSORIES



MAXUM Concentric Reducer

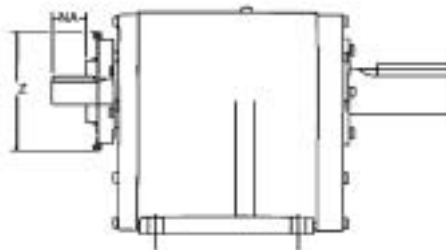

BACKSTOP ASSEMBLIES

Optional backstops are offered for service conditions that require the prevention of reverse direction. All backstops are externally mounted on the high speed shaft. On reducer sizes 1 through 6, the backstop is a ratchet and pawl type that does not require additional shaft length to mount. On sizes 7 through 12, a sprag type backstop mounts on an extended high speed shaft which is supplied with the backstop reducer.

NOTE: All backstops have a maximum overrunning speed limitation of 1800 RPM. In addition, the ratchet and pawl type on reducer sizes 1-6 has a minimum overrunning speed limitation of 400 RPM.

When ordering a reducer with backstop, it will be necessary to indicate on the order the desired direction of rotation of the output shaft, either by designating "CW" for clockwise or "CCW" for counter clockwise, when looking at the output shaft. Backstop is factory installed on sizes 7-12, specify rotation. Sizes 1-6 factory installed upon request. For sizes 1-3, check availability.

External Backstops (sizes 1 thru 6) ■

Unit Size	Ratios +	Part Number	NA	Z	Backstop Max. HP
DCR/TCR 1	2.25-194.6	299375	1.53	8.69	30
DCR/TCR 2	2.25-194.6	299375	1.53	8.69	30
DCR/TCR 3	7.59-194.6	299375	1.97	8.69	50
DCR/TCR 4	13.95-194.6	299375	1.97	8.69	50
DCR 5	9.30-25.63	299377	2.69	9.75	75
TCR 5	31.39-194.6	299377	1.61	9.75	50
DCR 6	13.95-25.63	299377	2.69	9.75	75
TCR 6	31.39-194.6	299377	1.61	9.75	50

+ For backstops on ratios not listed, application HP can not exceed the backstop maximum HP rating.

■ Refer to Table 12, page G3-34 for compatibility of various combinations of reducers and accessories.

■ Sizes 1-3 discontinued. Remaining stock may be available

WARNING: Backstops are not to be used for applications involving energy absorption and shock or torque loads in excess of reducer ratings nor on applications such as chair lifts, amusement rides, etc., and where the safety of persons or property is dependent on their function. On such applications, other holding devices must be provided.



MAXUM Concentric Reducer EXTERNAL BACKSTOPS (SIZE 7 THRU 12) ■

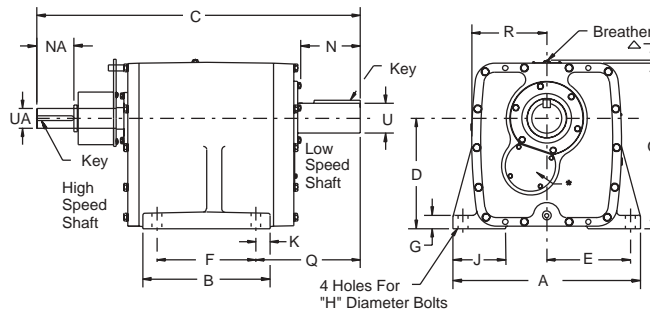

△ 1-1/2" will clear breather on all size units.

Size	Ratios	Part Number *	C	NA	UA	
					Shaft Diameter	Key
DCR 7	5.06-25.63	299379	41.97	3.75	1.999/1.998	1/2 x 31/2
TCR 7	31.39-194.6	299380	40.79	2.69	1.311/1.310	5/16 x 21/2
DCR 9	5.06-11.39	299384	53.46	3.75	2.7485/2.7475	5/8 x 31/2
DCR 9	13.95-25.63	299385	52.08	3.75	1.999/1.998	1/2 x 31/2
TCR 9	31.39-194.6	299386	49.47	3.75	1.999/1.998	1/2 x 31/2
DCR 10	5.06-11.39	299387	54.27	3.75	2.7485/2.7475	5/8 x 31/2
DCR/TCR 10	13.95-70.62	299388	52.90	3.75	1.999/1.998	1/2 x 31/2
TCR 10	86.50-194.6	299389	50.38	3.75	1.999/1.998	1/2 x 31/2
DCR 11	5.06-11.39	299390	57.19	3.75	3.2485/3.2475	3/4 x 31/2
DCR 11	13.95-25.63	299391	55.94	3.75	2.7485/2.7475	5/8 x 31/2
TCR 11	31.39-70.62	299392	54.57	3.75	1.999/1.998	1/2 x 31/2
TCR 11	86.50-194.6	299845	52.79	3.75	1.999/1.998	1/2 x 31/2
DCR 12	6.20-11.39	299393	57.72	3.75	3.2485/3.2475	3/4 x 31/2
DCR 12	13.95-25.63	299394	56.48	3.75	2.7485/2.7475	5/8 x 31/2
TCR 12	31.39-70.62	299395	55.10	3.75	1.999/1.998	1/2 x 31/2
TCR 12	86.50-194.6	299846	53.36	3.75	1.999/1.998	1/2 x 31/2

* External backstop assembly only. See Specification/Dimensions Section pages G3-23 through G3-33 for MAXUM Backstop Reducer part numbers. (Reducers have extended high speed shafts for mounting of external backstops.)

MAXUM REDUCER BASIC DIMENSIONS

Unit Size	A	B	D	E	F	G	H	J	N	O	Q	R	U	
													Shaft Dia.	Key Size
7	25.49	18.50	14.80	11.22	14.70	1.80	11/4	7.06	8.05	22.31	14.09	10.17	4.00	1 x 1 x 6-1/4
9	31.50	22.00	18.13	13.44	18.19	2.19	11/2	10.00	10.67	27.38	17.49	11.94	5.25	1-1/4 x 1-1/4 x 8-13/16
10	29.93	24.00	18.38	13.10	20.25	2.25	11/2	9.00	11.00	28.43	16.67	12.76	6.00	1-1/2 x 1-1/2 x 8-3/4
11	33.02	24.25	20.75	14.44	20.38	2.50	13/4	9.00	11.51	32.11	17.93	14.54	6.50	1-1/2 x 1-1/2 x 9-1/4
12	34.46	24.88	23.38	15.20	21.00	2.75	13/4	9.00	12.00	35.79	18.17	16.18	7.00	1-3/4 x 1-3/4 x 9-5/32

Refer to Table 12, page G3-34 for compatibility of various combinations of reducers and accessories

FEATURES/BENEFITS PAGE G3-3	NOMENCLATURE PAGE G3-6	EASY SELECTION PAGE G3-7	RELATED PRODUCTS PAGE G3-55
--------------------------------	---------------------------	-----------------------------	--------------------------------

MODIFICATIONS/ ACCESSORIES

DODGE®

MAXUM Concentric Reducer

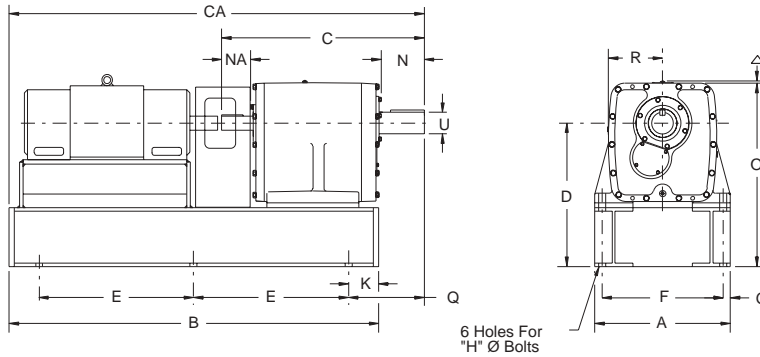

6 Holes For
"H" Ø Bolts

△ 1-1/2" will clear breather on all reducers.

HD BASEPLATE ASSEMBLIES

Heavy Duty Baseplates are rigid units fabricated of heavy steel, providing a sturdy mounting base for motor/coupling/reducer combinations. This accessory is recommended for large motors where the motor weight exceeds the reducer weight or 700 lbs. and for variable speed DC or AC application regardless of the motor weight. The combination of a factory mounted Reliance motor, DODGE coupling, MAXUM reducer and HD baseplate becomes a drive package warranted as a single system.

HD baseplate assemblies include baseplate, Para-Flex coupling and coupling guard.

When mounting variable speed AC or DC motors, consult general guidelines on pages G3-81 and G3-82.

Consult DODGE for size 7-12 baseplate dimensions.



FEATURES/BENEFITS PAGE G3-3	NOMENCLATURE PAGE G3-6	EASY SELECTION PAGE G3-7	RELATED PRODUCTS PAGE G3-55
--------------------------------	---------------------------	-----------------------------	--------------------------------



MAXUM Concentric Reducer

MAXUM REDUCER HD BASEPLATES WITH RELIANCE RPM III DC MOTORS ▲

Reducer/Motor*	B	CA	E	A	C	D	F	G	H	K	N	O	R	U	Q	NA	
DCR/TCR 1	1811	38.50	43.22	17.25	11.75	18.67	12.80	10.40	0.68	1/2"	2.00	3.50	16.64	4.94	1.750	6.72	3.05
	1812	38.50	43.22	17.25													
	2113	48.00	52.72	22.00													
DCR/TCR 2	1811	40.50	44.96	17.25	12.75	20.63	13.50	11.20	0.77	5/8"	3.00	4.25	17.50	5.13	2.125	7.46	3.05
	1812	40.50	44.96	17.25													
	2113	50.50	54.96	22.25													
DCR/TCR 3	2512	53.00	57.46	23.50	15.25	23.08	15.00	13.20	1.02	3/4"	3.00	5.25	19.88	6.19	2.625	8.78	3.50
	1811	42.00	47.78	18.00													
	1812	42.00	47.78	18.00													
	2113	51.50	57.28	22.75													
DCR/TCR 4	2512	54.50	60.28	24.25	16.88	25.47	18.10	14.60	1.14	7/8"	3.00	5.75	22.97	6.69	2.875	9.45	3.50
	2812	59.00	64.78	26.50													
	1811	43.50	49.95	18.75													
	1812	43.50	49.95	18.75													
	2113	53.00	59.45	23.50													
	3210	62.50	68.95	28.25													
	3212	62.50	68.95	28.25													
DCR5	2812	60.50	66.95	27.25	18.63	29.14	18.46	16.40	1.11	1"	3.00	6.75	23.94	7.44	3.375	10.75	4.51
	3210	64.50	72.25	29.25													
	1811	45.50	53.25	19.75													
	1812	45.50	53.25	19.75													
	2113	55.00	62.75	24.50													
	2512	58.50	66.25	26.25													
	2812	63.00	70.75	28.50													
TCR5	3210	64.50	72.25	29.25	18.63	28.05	18.46	16.40	1.11	1"	3.00	6.75	23.94	7.44	3.375	10.75	3.42
	3212	63.50	71.25	28.75													
	1811	45.00	52.75	19.50													
	1812	45.00	52.75	19.50													
	2113	54.50	62.25	24.25													
	2512	57.50	65.25	25.75													
	2812	62.00	69.75	28.00													
DCR6	3210	63.50	71.25	28.75	21.38	31.44	20.16	18.60	1.39	11/8"	3.00	7.50	26.66	8.16	3.750	11.91	4.51
	3212	65.50	74.41	29.75													
	3612	71.00	79.91	32.50													
	1811	46.50	55.41	20.25													
	1812	46.50	55.41	20.25													
	2113	56.00	64.91	25.00													
	2512	60.50	69.41	27.25													
	2812	64.00	73.91	29.00													
TCR6	3210	65.50	74.41	29.75	21.38	30.36	20.16	18.60	1.39	11/8"	3.00	7.50	26.66	8.16	3.750	11.91	3.42
	3212	64.50	73.41	29.25													
	3612	70.00	78.91	32.00													
	1811	46.00	54.91	20.00													
	1812	46.00	54.91	20.00													
	2113	55.50	64.41	24.75													
	2512	58.50	67.41	26.25													
	2812	63.00	71.91	28.50													

▲ For dimensions on HD Baseplates for sizes 7-12, consult DODGE.

* All motors are suffixed by "ATZ." Reliance RPM III motors used as a guide for dimensions.

Consult DODGE when mounting non-Reliance Electric motors.

Sizes 1-3 discontinued. Remaining stock may be available

FEATURES/BENEFITS PAGE G3-3	NOMENCLATURE PAGE G3-6	EASY SELECTION PAGE G3-7	RELATED PRODUCTS PAGE G3-55
--------------------------------	---------------------------	-----------------------------	--------------------------------

MODIFICATIONS/ ACCESSORIES



MAXUM Concentric Reducer

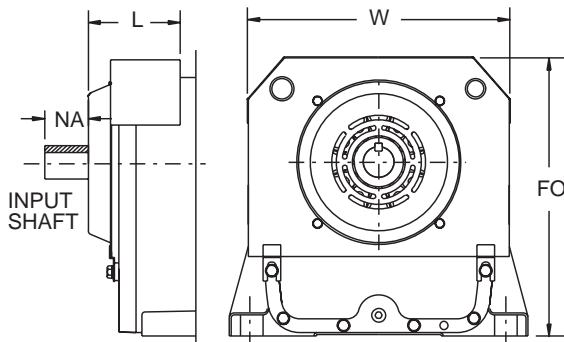

COOLING FANS

When the thermal capacity of the MAXUM Concentric Shaft Reducer is exceeded, cooling fans provide an optional, inexpensive way of lowering the oil temperature thus increasing the thermal horsepower capacity of the reducer. Selection tables indicate the need for cooling fans. Refer to the thermal tables on pages G3-68 and G3-69. For thermal capacities beyond the range of cooling fans, heat exchangers may be used - see below. Installation of the fan is accomplished simply by attaching formed steel mounting straps to the reducer input cover. The fan assembly, which fastens to the reducer high speed shaft, is simple and compact yet designed to allow an efficient flow of air.

NOTE: When using fans with backstops or top motor mounts, see **Accessory Compatibility Matrix**, page G3-34, or consult DODGE.

NOTE: Viton seals are available for MAXUM reducers in high temperature applications. Consult DODGE.

Dimensions for MAXUM Reducer with Cooling Fan

Unit Size	Part Number	NA	L	W	FO
DCR 3	299519	1.78	5.75	14.50	15.00
DCR 4	299520	1.78	5.75	14.50	16.13
DCR 5	299521	2.69	6.69	17.00	17.44
DCR 6	299522	2.69	6.69	18.75	19.94
DCR 7	299523	3.75	7.94	22.44	24.00
DCR 9	299525	3.75	10.19	26.38	29.00
DCR 10	299526	3.75	10.19	28.00	29.94
TCR 10	299842	3.75	10.19	28.00	29.94
DCR 11	299527	3.75	10.19	31.63	33.75
TCR 11	299843	3.75	10.19	31.63	33.75
DCR 12	299528	3.75	10.19	33.75	37.44
TCR 12	299844	3.75	10.19	33.75	37.44

Sizes 1-3 discontinued. Remaining stock may be available

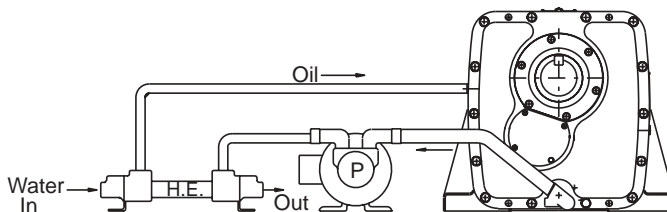

HEAT EXCHANGER COOLING PACKAGES

For thermal capacities beyond the range of cooling fans, an optional heat exchanger cooling package is available to achieve the use of full mechanical HP rating by lowering the oil temperature.

The cooling package is available to cover the basic reducer sizes 3 through 12. (See thermal HP table on pages G3-68 and G3-69.)

Specifications for the heat exchanger motor are as follows: 1/2 HP, 60 Hz, 3 Ph, 230/460 Volt, TEFC, 56 Frame. Minimum coolant (water) flow is 3 G.P.M. based upon a maximum water temperature of 80°F. Minimum oil temperature for operation is 60°F.

Available from stock as part number **014148**.

FEATURES/BENEFITS
PAGE G3-3

NOMENCLATURE
PAGE G3-6

EASY SELECTION
PAGE G3-7

RELATED PRODUCTS
PAGE G3-55



MAXUM Concentric Reducer



SCOOP MOUNT MOTOR/REDUCERS

DODGE MAXUM Scoop Mount Motor/Reducers are available in 12 sizes ranging from 1 to 250 horsepower. Case sizes 4-6 feature AGMA standard speeds 9 to 778 RPM, and case sizes 7-12 feature AGMA standard speeds from 9 to 350 RPM.

DODGE MAXUM Scoop Mount Motor/Reducers can be supplied with factory-mounted Reliance AC motors. Or, if preferred, scoop mount reducers may be ordered separately for use with customer supplied AC motors. Gray iron cases come with steel scoops designed to accept NEMA AC motor frame sizes from 143T through 445T.

DODGE flexible PARA-FLEX® couplings are standard, however, DODGE grid couplings are also available as an optional item.

Thermally limited DODGE MAXUM Scoop Mount Motor/Reducers should be equipped with cooling fan or heat exchanger as required.

Scoops can be used in conjunction with some other accessories. Refer to Table 12, page G3-34.

CAUTION: The customer is responsible and Reliance Electric expressly disclaims responsibility for isolating the DODGE MAXUM Scoop Mount Motor/Reducer from any vibratory or transient load induced by the motor or the other equipment that is driven by the motor.

The MAXUM Scoop Mount Motor/Reducer is expressly not warranted against failure or unsatisfactory operation

resulting from dynamic vibrations of any form imposed upon it whether by the drive system in which it is installed or for any other reason, no matter how induced, unless the nature of such vibrations has been fully defined by the customer on the face of its purchase order and explicitly accepted in writing by Reliance Electric.

DRIVE SYSTEM VIBRATION

The probability of a constant speed motor operating at resonant frequency is remote. Should this occur however, the customer must add stiffening supports to the scoop bottom

plate to move the resonant frequency away from the motor operating speed.

When mounting variable speed AC or DC motors, consult guidelines on page G3-81 and G3-82.

FEATURES/BENEFITS PAGE G3-3	NOMENCLATURE PAGE G3-6	EASY SELECTION PAGE G3-7	RELATED PRODUCTS PAGE G3-55
--------------------------------	---------------------------	-----------------------------	--------------------------------

MODIFICATIONS/ ACCESSORIES



MAXUM Concentric Reducer

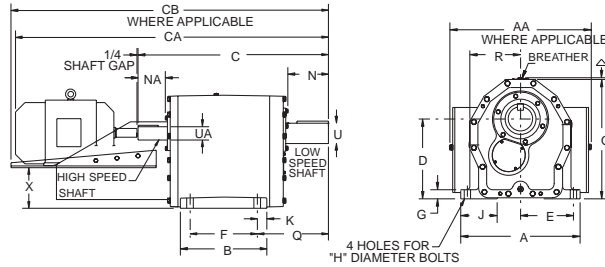

SCOOP MOUNT MOTOR/REDUCERS WITH AC MOTORS, SIZE 1-4 (WITHOUT EXTERNAL BACKSTOP)

MAXUM Size	A	B	C		D	E	F	G	H Bolts	J	K	N	NA	
			Double Red. Units	Triple Red. Units									Dbl. Red. Units w/o Fan	Triple Red. Units
1	11.75	7.25	18.67	18.67	6.30	5.20	6.00	0.69	1/2	2.88	.63	3.50	3.05	3.05
2	12.75	8.50	20.63	20.63	7.00	5.60	7.13	0.81	5/8	3.28	.69	4.25	3.05	3.05
3	15.25	9.50	23.08	23.08	8.50	6.60	7.75	0.94	3/4	4.31	.88	5.25	3.50	3.50
4	16.88	11.25	25.47	25.47	9.60	7.30	9.00	1.13	7/8	4.50	.92	5.75	3.50	3.50

MAXUM Size	O	Q	R	U		UA				Avg. Reducer Wt. (lbs.)
				Shaft Dia	Key Size	Dbl. Reduction Units		Triple Reduction Units		
						Shaft Dia	Key Size	Shaft Dia	Key Size	
1	10.14	6.72	4.94	1.750	3/8 x 3/8 x 2-3/4	1.375	5/16 x 5/16 x 2-3/16	1.375	5/16 x 5/16 x 2-3/16	130
2	11	7.46	5.13	2.125	1/2 x 1/2 x 3-1/4	1.375	5/16 x 5/16 x 2-3/16	1.375	5/16 x 5/16 x 2-3/16	167
3	13.38	8.78	6.19	2.625	5/8 x 5/8 x 4-11/16	1.625	3/8 x 3/8 x 2-1/2	1.625	3/8 x 3/8 x 2-1/2	240
4	14.47	9.45	6.69	2.875	3/4 x 3/4 x 5	1.625	3/8 x 3/8 x 2-1/2	1.625	3/8 x 3/8 x 2-1/2	340

MAXUM Size	Dimensional Ref.	143T	145T	182T	184T	213T	215T	254T	256T	284T	286T	324T	326T
		1	AA❖	13.60	13.60	13.60	13.60	13.60	13.60				
	CA+	30.42	32.42	33.54	34.54	36.73	38.23						
	CB	34.14	34.14	34.14	N/A	N/A	N/A						
	X	2.55	2.55	1.55	1.55	0.80	0.80						
2	AA❖	16.77	16.77	16.77	16.77	16.77	16.77	16.77	16.77				
	CA+	32.38	34.38	35.50	36.50	38.69	40.19	43.63	45.38				
	CB	41.10	41.10	41.10	41.10	41.10	41.10	N/A	N/A				
	X	3.19	3.19	2.19	2.19	1.44	1.44	0.44	0.44				
3	AA❖	16.77	16.77	16.77	16.77	16.77	16.77	16.77	16.77	20.15	20.15		
	CA+	34.83	36.83	37.95	38.95	41.14	42.64	46.08	47.83	49.27	50.77		
	CB	43.55	43.55	43.55	43.55	43.55	43.55	N/A	N/A	N/A	N/A		
	X	4.69	4.69	3.69	3.69	2.94	2.94	1.94	1.94	1.19	1.19		
4	AA❖	16.90	16.90	16.90	16.90	16.90	16.90	16.90	16.90	20.27	20.27	20.27	20.27
	CA+	37.22	39.22	40.34	41.34	43.53	45.03	48.47	50.22	51.66	53.16	54.66	56.16
	CB	45.94	45.94	45.94	45.94	45.94	45.94	N/A	N/A	N/A	N/A	N/A	N/A
	X	5.79	5.79	4.79	4.79	4.04	4.04	3.04	3.04	2.29	2.29	1.29	1.29

Δ 1-1/2" will clear breather on all size units.

❖ AA = Scoop width plus head thickness of mounting bolts.

+ Approx. overall length using squirrel cage, induction Reliance AC motor of the fan cooled type and DODGE couplings from page G3-55.

NOTE: Scoops are designed for standard size conduit boxes.

Upsize conduit boxes may interfere with side plates.

☐ Sizes 1-3 discontinued. Remaining stock may be available

FEATURES/BENEFITS PAGE G3-3	NOMENCLATURE PAGE G3-6	EASY SELECTION PAGE G3-7	RELATED PRODUCTS PAGE G3-55
--------------------------------	---------------------------	-----------------------------	--------------------------------



MAXUM Concentric Reducer

SCOOP MOUNT MOTOR/REDUCERS WITH AC MOTORS, SIZES 5-9 (WITHOUT EXTERNAL BACKSTOP)

MAXUM Size	A	B	C		D	E	F	G	H Bolts	J	K	N	NA	
			Double Red. Units	Triple Red. Units									Dbl. Red. Units w/o Fan	Triple red Units
5	18.63	12.00	29.14	28.05	9.96	8.20	10.00	1.25	1	4.19	1.00	6.75	4.51	3.42
6	21.38	13.81	31.44	30.36	11.66	9.30	11.30	1.38	1-1/8	4.50	1.25	7.50	4.51	3.42
7	25.49	18.50	39.06	37.64	14.80	11.22	14.70	1.80	1-1/4	7.06	1.90	8.05	5.41	3.77
9	31.50	22.00	47.39	45.70	18.13	13.44	18.19	2.19	1-1/2	10.00	1.89	10.67	6.25	4.23

MAXUM Size	O	Q	R	U		UA				Ave. Reducer Wt. (lbs.)
				Shaft dia.	Key Size	Double Reduction Units		Triple Reduction Units		
						Shaft Dia.	Key Size	Shaft Dia.	Key Size	
5	15.44	10.75	7.44	3.375	7/8 x 7/8 x 51/4	2.125	1/2 x 1/2 x 33/8	1.625	3/8 x 3/8 x 21/2	435
6	18.16	11.91	8.16	3.750	7/8 x 7/8 x 53/4	2.125	1/2 x 1/2 x 33/8	1.625	3/8 x 3/8 x 21/2	615
7	22.31	14.09	10.17	4.000	1 x 1 x 61/4	2.625	5/8 x 5/8 x 41/4	1.875	1/2 x 1/2 x 21/2	1200
9	27.38	17.49	11.94	5.250	1 1/4 x 1 1/4 x 813/16	3.000	3/4 x 3/4 x 47/8	2.125	1/2 x 1/2 x 33/8	2200

MAXUM Size	Dimensional Ref.	Red.	182T	184T	213T	215T	254T	256T	284T	286T	324T	326T	364T/365T	404T/405T	444T/445T
5	AA❖		24.67	24.67	24.67	24.67	24.67	24.67	24.67	24.67	24.67	24.67	24.67		
	CA+	DCR★ TCR■	44.01 42.92	45.01 43.92	47.20 46.11	48.70 47.61	52.14 51.05	53.89 52.80	55.33 54.24	56.83 55.74	58.33	59.83	62.83		
	CB	DCR★ TCR■	56.27 55.18	56.27 55.18	56.27 55.18	56.27 55.18	56.27 55.18	56.27 55.18	56.27 55.18	N/A N/A	N/A	N/A	N/A		
	X		5.01	5.01	4.26	4.26	3.26	3.26	2.51	2.51	1.51	1.51	0.51		
6	AA❖			24.67	24.67	24.67	24.67	24.67	24.67	24.67	24.67	24.67	24.67		
	CA+	DCR★ TCR■		47.31 46.23	49.50 48.42	51.00 49.92	54.44 53.36	56.19 55.11	57.63 56.55	59.13 58.05	60.63 59.55	62.13 61.05	65.13 64.05		
	CB	DCR★ TCR■		58.57 57.49	58.57 57.49	58.57 57.49	58.57 57.49	58.57 57.49	58.57 57.49	N/A N/A	N/A N/A	N/A N/A	N/A N/A		
	X			6.72	5.97	5.97	4.97	4.97	4.22	4.22	3.22	3.22	2.22		
7	AA❖				24.67	24.67	24.67	24.67	24.67	24.67	24.67	24.67	24.67	27.15	27.15
	CA+●	DCR★ TCR■			57.12 55.70	58.62 57.20	62.06 60.64	63.81 62.39	65.25 63.83	66.75 65.33	68.25 66.83	69.75 68.33	72.75 71.33	77.62	83.93
	CB●	DCR★ TCR■			65.68 64.26	65.68 64.26	65.68 64.26	65.68 64.26	66.19 64.77	N/A N/A	N/A N/A	N/A N/A	N/A N/A	N/A	N/A
	X				9.12	9.12	8.12	8.12	7.37	7.37	6.37	6.37	5.37	4.37	3.37
9	AA❖						34.65	34.65	34.65	34.65	34.65	34.65	34.65	34.65	34.65
	CA+●	DCR★ TCR■						68.70	70.45	71.89	73.39	74.89	76.39	81.08	85.95
	CB●	DCR★ TCR■						72.58	72.58	72.58	N/A	N/A	N/A	79.39	84.26
	X							11.82	11.82	11.07	11.07	10.07	10.07	9.07	8.07

- Δ 1-1/2" will clear breather on all size units.
 ❖ When using external backstops on sizes 7, 8 and 9, see page G3-37 for UA and NA dimensions.
 ❖ AA = Scoop width plus head thickness of mounting bolts.
 + Approx. overall length using squirrel cage, induction Reliance AC motor of the fan cooled type and DODGE couplings from page G3-55.
- ★ Double Reduction reducer only.
 ■ Triple Reduction reducer only.
 ● When using external backstops on sizes 7, 8 and 9, consult DODGE for scoop dimensions.
- NOTE:** Scoops are designed for standard size conduit boxes. Oversize conduit boxes may interfere with side plates.

FEATURES/BENEFITS PAGE G3-3	NOMENCLATURE PAGE G3-6	EASY SELECTION PAGE G3-7	RELATED PRODUCTS PAGE G3-55
--------------------------------	---------------------------	-----------------------------	--------------------------------

MODIFICATIONS/ ACCESSORIES



MAXUM Concentric Reducer

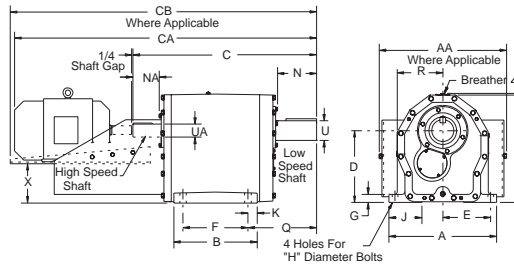

SCOOP MOUNT MOTOR/REDUCER WITH AC MOTORS, SIZES 10 - 12 (WITHOUT EXTERNAL BACKSTOP)

MAXUM Size	A	B	C		D	E	F	G	H Bolts	J	K	N	NA ♦		
			Ratios 5.06-70.62	Ratios 86.50-194.6									Dbl. Red. Units w/o Fan	Triple Red Units	
													31.39-70.62	86.50-194.6	
10	29.93	24.00	48.20	47.09	18.38	13.10	20.25	2.25	1-1/2	9.00	1.87	11.00	6.31	5.90	4.78
11	33.02	24.25	49.84	48.65	20.75	14.44	20.38	2.50	1-3/4	9.00	1.94	11.51	5.33	5.37	4.18
12	34.46	24.88	50.41	49.22	23.38	15.20	21.00	2.75	1-3/4	9.00	1.94	12.00	5.33	5.37	4.18

MAXUM Size	O	Q	R	U			UA ♦				Avg. Reducer Wt. (Lbs.)		
				Shaft Dia.	Key Size		Dbl. Reduction Units		Triple Reduction Units				
					Shaft Dia.	Key Size ▲	Shaft Dia.	Key Size ▲					
10	28.43	16.67	12.76	6.00	1-1/2 x 1-1/2 x 8-3/4		3.500	7/8 x 7/8 x 4-7/8		2.375	5/8 x 5/8 x 3-3/4		2485
11	32.11	17.93	14.54	6.50	1-1/2 x 1-1/2 x 9-1/4		3.750	7/8 x 7/8 x 4-1/2		2.375	5/8 x 5/8 x 3-3/4		3320
12	35.79	18.17	16.18	7.00	1-3/4 x 1-3/4 x 9-5/32		3.750	7/8 x 7/8 x 4-1/2		2.375	5/8 x 5/8 x 3-3/4		4100

MAXUM Size	Dimensional Ref.	Red.	256T	284T	286T	324T	326T	364T	365T	404T	405T	444T/445T
10	AA❖		34.65	34.65	34.65	34.65	34.65	34.65	34.65	34.65	34.65	34.65
	CA+●	DCR★ TCR■	72.97	74.41	75.91	77.41	78.91	81.91	81.91	86.78	86.78	93.07 93.09
	CBD	TCR■	75.42	75.42	N/A	N/A	N/A	N/A	N/A	N/A	N/A	N/A
	X		11.69	10.94	10.94	9.94	9.94	8.94	8.94	7.94	7.94	6.94
11	AA❖			34.65	34.65	34.65	34.65	34.65	34.65	34.65	34.65	34.65
	CA+●	DCR★ TCR■		76.03	77.53	79.03	80.53	83.53	83.53	88.40	88.40	94.71
	CBD	TCR■		76.97	N/A	N/A	N/A	N/A	N/A	N/A	N/A	N/A
	X			13.32	13.32	12.32	12.32	11.32	11.32	10.32	10.32	9.32
12	AA❖			34.65	34.65	34.65	34.65	34.65	34.65	34.65	34.65	34.65
	CA+●	DCR★ TCR■		76.60	78.10	79.60	81.10	84.10	84.10	88.97	88.97	95.28
	CB●	DCR★		N/A	N/A	N/A	N/A	N/A	N/A	N/A	N/A	N/A
	X			15.94	15.94	14.94	14.94	13.94	13.94	12.94	12.94	11.94

- △ 1-1/2, will clear breather on all size units.
 - ❖ AA = Scoop width plus head thickness of mounting bolts.
 - + Approx. overall length using squirrel cage, induction Reliance AC motor of the fan cooled type and DODGE couplings from page G3-55.
 - ▲ On ratios 31.39-70.62 key length is 4-15/16.
 - ★ Double Reduction reducer only.
 - ♦ When using external backstops on sizes 10, 11 and 12, see page G3-37 for UA and NA dimensions.
 - Triple Reduction reducer only.
 - On ratios 86.50-194.6, dimension CA will be approximately 1.25" shorter. When using external backstops, consult DODGE for scoop dimensions.
- NOTE:** Scoops are designed for standard size conduit boxes. Oversize conduit boxes may interfere with side plates.

FEATURES/BENEFITS PAGE G3-3	NOMENCLATURE PAGE G3-6	EASY SELECTION PAGE G3-7	RELATED PRODUCTS PAGE G3-55
--------------------------------	---------------------------	-----------------------------	--------------------------------



MAXUM Concentric Reducer

COUPLING GUARDS

MAXUM coupling guards, made of fabricated steel, are available for use with MAXUM Concentric Shaft Scoop/Motor/Reducers sizes 1-12 and are supplied as part of scoop or baseplate package unless specified otherwise. They offer positive protection from objects falling into the rotating coupling.

When considering other combinations or non-DODGE couplings, consult DODGE.

NOTE: Coupling guards are designed for use on reducers without backstops.

COUPLING GUARD PART NUMBERS ■

GUARD NUMBER	PART NUMBER	MAXUM CASE SIZE	MOTOR FRAMES
1	299451	DCR/TCR 1 & 2	140-210T
2	299452	DCR 2	250T
3	299453	DCR/TCR 3 & 4 TCR 5 & 6	140-210T
4	299454	DCR/TCR 3 & 4 TCR 5 & 6	250-280T
5	299455	DCR 4, TCR 6	320T
6	299456	TCR 6	360T
7	299457	DCR 5 & 6	180-250T
8	299458	DCR 5 & 6	280-360T
11	299461	TCR 7	210-250T
12	299462	TCR 7 DCR 7	280-360T 250T
14	299464	DCR 7	280-360T
15	304938	DCR 7	400T
16	304939	DCR 7	440T
17	299467	TCR 9	250-280T
18	299468	TCR 9	320-360T
19	299469	TCR 9	400T
20	299470	TCR 9	440T
21	299471	DCR 9	360T
22	304940	DCR 9	400T
23	304941	DCR 9	440T
24	299474	TCR 10	250-280T
25	299475	TCR 10	320-360T
26	299476	TCR 10 ▲	400T
27	299477	TCR 10 ▲	440T
28	304942	DCR/TCR 10 ★	400T
29	304943	DCR/TCR 10 ★	440T
30	299480	TCR 11 & 12	280-360T
31	299481	TCR 11 & 12 ▲	400T
32	299482	TCR 11 & 12 ▲	440T
33	304947	DCR/TCR 11 & 12 ★	400T
34	304950	DCR/TCR 11 & 12 ★	440T
35	304936	DCR 10, 11 & 12	360T

‡ Refers to maximum size coupling that guard is designed to cover. Actual coupling supplied by DODGE in scoop or baseplate package may be a smaller size.

★ Triple reduction ratios 31.39-70.62.

▲ Triple reduction ratios 86.50-194.6.

■ Refer to Table 12, page G3-34 for compatibility of various combinations of reducers and accessories. See pages G3-55 and G3-56 for listing of coupling sizes.

■ Sizes 1-3 discontinued. Remaining stock may be available



Motor Mtg. Hardware Kit

AC Motor Frame Size	Ordering Number †	Description †
140T	014524	5/6" Bolts Kit
180T, 210T	014525	3/8" Bolts Kit
250T, 280T	014526	1/2" Bolts Kit
320T, 360T	014527	5/8" Bolts Kit
400T, 440T	014528	3/4" Bolts Kit

† Bolt Kits include bolts and shims for mounting motor to scoop

FEATURES/BENEFITS PAGE G3-3	NOMENCLATURE PAGE G3-6	EASY SELECTION PAGE G3-7	RELATED PRODUCTS PAGE G3-55
--------------------------------	---------------------------	-----------------------------	--------------------------------

MODIFICATIONS/ ACCESSORIES



MAXUM Concentric Reducer

SCOOP PACKAGES WITH PARA-FLEX COUPLINGS ■ ◆

MAXUM Size	Scoop Package Part Number	Side Plate	Bottom Plate	Motor Mounting Bolt Kit	Coupling Element	Quantity (2) Coupling Flange	Reducer Bushing	Motor Bushing	Coupling Guard Assembly	Scoop Package Weight (lbs.)
1	DCS01140P	299501	299589	014524	011106	010602	119404	119396	299451	60.2
1	DCS01180P	299501	299589	014525	011106	010602	119404	119400	299451	60.2
1	DCS01210P	299501	299589	014525	011106	010602	119404	119404	299451	60.2
1	TCS01140P	299501	299589	014524	011106	010602	119404	119396	299451	60.2
1	TCS01180P	299501	299589	014525	011106	010602	119404	119400	299451	60.2
2	DCS02140P	299502	299590	014524	011106	010602	119404	119396	299451	101.2
2	DCS02180P	299502	299590	014525	011106	010602	119404	119400	299451	101.2
2	DCS02210P	299502	299590	014525	011106	010602	119404	119404	299451	101.2
2	DCS02250P	299502	299590	014526	011107	010603	119225	119229	299452	116.0
2	TCS02140P	299502	299590	014524	011106	010602	119404	119396	299451	101.2
2	TCS02180P	299502	299590	014525	011106	010602	119404	119400	299451	101.2
2	TCS02210P	299502	299590	014525	011106	010602	119404	119404	299451	101.2
3	DCS03140P	299503	299590	014524	011106	(1)	009212	009208	299453	110.6
3	DCS03180P	299503	299590	014525	011107	010603	119229	119221	299453	120.0
3	DCS03210P	299503	299590	014525	011107	010603	119229	119225	299453	120.0
3	DCS03250P	299503	299590	014526	011107	010603	119229	119229	299454	125.0
3	DCS03280P	299503	299591	014526	011108	010604	117092	117095	299454	148.6
3	TCS03140P	299503	299590	014524	011106	(1)	009212	000590	299453	110.6
3	TCS03180P	299503	299590	014525	011107	010603	000598	119221	299453	120.0
3	TCS03210P	299503	299590	014525	011107	010603	119229	119225	299453	120.0
3	TCS03250P	299503	299590	014526	011107	010603	119229	119229	299454	125.0
4	DCS04140P	299504	299590	014524	011106	(1)	009212	009208	299453	135.4
4	DCS04180P	299504	299590	014525	011107	010603	119229	119221	299453	138.0
4	DCS04210P	299504	299590	014525	011107	010603	119229	119225	299453	138.0
4	DCS04250P	299504	299590	014526	011107	010603	119229	119229	299454	143.0
4	DCS04280P	299504	299591	014526	011108	010604	117092	117095	299454	166.6
4	DCS04320P	299504	299591	014527	011108	010604	117092	117177	299455	173.6
4	TCS04140P	299504	299590	014524	011106	(1)	009212	009208	299453	135.4
4	TCS04180P	299504	299590	014525	011107	010603	119229	119221	299453	138.0
4	TCS04210P	299504	299590	014525	011107	010603	119229	119225	299453	138.0
4	TCS04250P	299504	299590	014526	011107	010603	119229	119229	299454	143.0
4	TCS04280P	299504	299591	014526	011108	010604	117092	117095	299454	166.6
5	DCS05210P	299505	299592	014525	011108	010604	117177	117091	299454	186.6
5	DCS05250P	299505	299592	014526	011108	010604	117177	117092	299457	186.6
5	DCS05280P	299505	299592	014526	011108	010604	117177	117095	299458	194.6
5	DCS05320P	299505	299592	014527	011108	010604	117177	117177	299458	194.6
5	DCS05360P	299505	299592	014527	011109	010605	119126	117098	299458	203.8
5	TCS05140P	299505	299592	014524	011106	(1)	009212	009208	299453	165.0
5	TCS05180P	299505	299592	014525	011107	010603	119229	119221	299453	174.0
5	TCS05210P	299505	299592	014525	011107	010603	119229	119225	299453	174.0
5	TCS05250P	299505	299592	014526	011107	010603	119229	119229	299454	179.0
5	TCS05280P	299505	299592	014526	011108	010604	117092	117095	299454	185.6
6	DCS06210P	299506	299592	014525	011108	010604	117177	117091	299457	197.6
6	DCS06250P	299506	299592	014526	011108	010604	117177	117092	299457	197.6
6	DCS06280P	299506	299592	014526	011108	010604	117177	117095	299458	205.6
6	DCS06320P	299506	299592	014527	011108	010604	117177	117177	299458	205.6
6	DCS06360P	299506	299592	014527	011109	010605	119126	117098	299458	214.8
6	TCS06180P	299506	299592	014525	011107	010603	119229	119221	299453	185.0

(1) Finished Bore PARA-FLEX Coupling. Part numbers listed in bushing columns are for the PX60FB hubs required to make a complete coupling.

■ Refer to Table 12, page G3-34 for compatibility of various combinations of reducers and accessories.

◆ When using external backstops on sizes 7 through 12 reducers with scoops, see page G3-37 for UA and NA dimensions. Change out TL Bushing or Finish bore hub to fit smaller input shaft diameter of backstop reducer.

■ Sizes 1-3 discontinued. Remaining stock may be available.

FEATURES/BENEFITS PAGE G3-3	NOMENCLATURE PAGE G3-6	EASY SELECTION PAGE G3-7	RELATED PRODUCTS PAGE G3-55
--------------------------------	---------------------------	-----------------------------	--------------------------------



MAXUM Concentric Reducer

SCOOP PACKAGES WITH PARA-FLEX COUPLINGS ■ ◆

MAXUM Size	Scoop Package Part Number	Side Plate	Bottom Plate	Motor Mounting Bolt Kit	Coupling Element	Quantity (2) Coupling Flange	Reducer Bushing	Motor Bushing	Coupling Guard Assembly	Scoop Package Weight (lbs.)
6	TCS06210P	299506	299592	014525	011107	010603	119229	119225	299453	185.0
6	TCS06250P	299506	299592	014526	011107	010603	119229	119229	299454	190.0
6	TCS06280P	299506	299592	014526	011108	010604	117092	117095	299454	196.6
6	TCS06320P	299506	299592	014527	011108	010604	117092	117177	299455	203.6
6	TCS06360P	299506	299592	014527	011109	010605	119144	117098	299456	217.8
7	DCS07250P	299507	299592	014526	011109	010605	117111	119144	299462	252.8
7	DCS07280P	299507	299592	014526	011109	010605	117111	119122	299464	252.8
7	DCS07320P	299507	299592	014527	011109	010605	117111	119126	299464	252.8
7	DCS07360P	299507	299592	014527	011109	010605	117111	117098	299464	252.8
7	DCS07400P	299507	299593	014528	011112	010608	117128	117132	304938	356.4
7	DCS07440P	299507	299593	014528	011114	011134	117224	117233	304939	436.0
7	TCS07210P	299507	299592	014525	011108	010604	117095	117091	299461	229.6
7	TCS07250P	299507	299592	014526	011108	010604	117095	117092	299461	229.6
7	TCS07280P	299507	299592	014526	011108	010604	117095	117095	299462	242.6
7	TCS07320P	299507	299592	014527	011108	010604	117095	117177	299462	242.6
7	TCS07360P	299507	299592	014527	011109	010605	119122	117098	299462	251.8
9	DCS09360P	299509	299594	014527	011112	010608	117134	117124	299471	362.4
9	DCS09400P	299509	299595	014528	011112	010608	117134	117132	304940	417.4
9	DCS09440P	299509	299595	014528	011114	011134	117229	117233	304941	500.0
9	TCS09250P	299509	299594	014526	011108	010604	117177	117092	299467	293.6
9	TCS09280P	299509	299594	014526	011108	010604	117177	117095	299467	293.6
9	TCS09320P	299509	299594	014527	011108	010604	117177	117177	299468	304.6
9	TCS09360P	299509	299594	014527	011109	010605	119126	117098	299468	313.8
9	TCS09400P	299509	299595	014528	011112	010608	117120	117132	299469	415.4
9	TCS09440P	299509	299595	014528	011114	011134	117218	117233	299470	498.0
10	DCS10360P	299510	299594	014527	011114	011134	117235	117221	304936	467.0
10	DCS10400P	299510	299595	014528	011114	011134	117235	117227	304942	509.0
10	DCS10440P	299510	299595	014528	011114	011134	117235	117233	304943	518.0
10	TCS10250P	299510	299594	014526	011109	010605	117098	119144	299474	316.8
10	TCS10280P	299510	299594	014526	011109	010605	117098	119122	299474	316.8
10	TCS10320P	299510	299594	014527	011109	010605	117098	119126	299475	335.8
10	TCS10360P	299510	299594	014527	011109	010605	117098	117098	299475	335.8
10	TCS10400P	299510	299595	014528	011112	010608	117124	117132	299476	432.4
10	TCS10440P	299510	299595	014528	011114	011134	117221	117233	299477	518.0
11	DCS11360P	299511	299594	014527	011114	011134	117709	117221	304936	490.0
11	DCS11400P	299511	299595	014528	011114	011134	117709	117227	304947	537.0
11	DCS11440P	299511	299595	014528	011114	011134	117709	117233	304950	550.0
11	TCS11280P	299511	299594	014526	011109	010605	117098	119122	299480	363.8
11	TCS11320P	299511	299594	014527	011109	010605	117098	119126	299480	363.8
11	TCS11360P	299511	299594	014527	011109	010605	117098	117098	299480	363.8
11	TCS11400P	299511	299595	014528	011112	010608	117124	117132	299481	458.4
11	TCS11440P	299511	299595	014528	011114	011134	117221	117233	299482	544.0
12	DCS12360P	299512	299594	014527	011114	011134	117709	117221	304936	505.0
12	DCS12400P	299512	299595	014528	011114	011134	117709	117227	299481	552.0
12	DCS12440P	299512	299595	014528	011114	011134	117709	117233	304950	565.0
12	TCS12280P	299512	299594	014526	011109	010605	117098	119122	299480	378.8
12	TCS12320P	299512	299594	014527	011109	010605	117098	119126	299480	378.8
12	TCS12360P	299512	299594	014527	011109	010605	117098	117098	299480	378.8
12	TCS12400P	299512	299595	014528	011112	010608	117124	117132	299481	473.4
12	TCS12440P	299512	299595	014528	011114	011134	117221	117233	299482	559.0

- Refer to Table 12, page G3-34 for compatibility of various combinations of reducers and accessories.
- ◆ When using external backstops on sizes 7 through 12 reducers with scoops, see page G3-37 for UA and NA dimensions. Change out TL Bushing or Finish bore hub to fit smaller input shaft diameter of backstop reducer.

FEATURES/BENEFITS PAGE G3-3	NOMENCLATURE PAGE G3-6	EASY SELECTION PAGE G3-7	RELATED PRODUCTS PAGE G3-55
--------------------------------	---------------------------	-----------------------------	--------------------------------

MODIFICATIONS/ ACCESSORIES



MAXUM Concentric Reducer SCOOP PACKAGES WITH GRID-LIGN COUPLINGS ■ ◆

MAXUM Size	Scoop Package Part Number	Side Plate	Bottom Plate	Motor Mounting Bolt Kit	Grid & Cover Assembly	Reducer Hub	Motor Hub	Coupling Guard Assy.	Scoop Package Weight (lbs.)
1	DCS01140G	299501	299589	014524	006751	006591	006587	299451	56.5
1	DCS01180G	299501	299589	014525	006751	006591	006589	299451	56.5
1	DCS01210G	299501	299589	014525	006751	006591	006591	299451	56.5
1	TCS01140G	299501	299589	014524	006751	006591	006587	299451	56.5
1	TCS01180G	299501	299589	014525	006751	006591	006589	299451	56.5
2	DCS02140G	299502	299590	014524	006751	006591	006587	299451	97.5
2	DCS02180G	299502	299590	014525	006751	006591	006589	299451	97.5
2	DCS02210G	299502	299590	014525	006751	006591	006591	299451	97.5
2	DCS02250G	299502	299590	014526	006752	006596	006598	299452	110.0
2	TCS02140G	299502	299590	014524	006751	006591	006587	299451	97.5
2	TCS02180G	299502	299590	014525	006751	006591	006589	299451	97.5
2	TCS02210G	299502	299590	014525	006751	006591	006591	299451	97.5
3	DCS03140G	299503	299590	014524	006752	006598	006592	299453	114.0
3	DCS03180G	299503	299590	014525	006752	006598	006594	299453	114.0
3	DCS03210G	299503	299590	014525	006752	006598	006596	299453	114.0
3	DCS03250G	299503	299590	014526	006752	006598	006598	299454	119.0
3	DCS03280G	299503	299591	014526	006753	006603	006605	299454	140.0
3	TCS03140G	299503	299590	014524	006752	006598	006592	299453	114.0
3	TCS03180G	299503	299590	014525	006752	006598	006594	299453	114.0
3	TCS03210G	299503	299590	014525	006752	006598	006596	299453	114.0
3	TCS03250G	299503	299590	014526	006752	006598	006598	299454	119.0
4	DCS04140G	299504	299590	014524	006752	006598	006592	299453	132.0
4	DCS04180G	299504	299590	014525	006752	006598	006594	299453	132.0
4	DCS04210G	299504	299590	014525	006752	006598	006596	299453	132.0
4	DCS04250G	299504	299590	014526	006752	006598	006598	299454	137.0
4	DCS04280G	299504	299591	014526	006753	006603	006605	299454	158.0
4	DCS04320G	299504	299591	014527	006754	006608	006611	299455	169.5
4	TCS04140G	299504	299590	014524	006752	006598	006592	299453	132.0
4	TCS04180G	299504	299590	014525	006752	006598	006594	299453	132.0
4	TCS04210G	299504	299590	014525	006752	006598	006596	299453	132.0
4	TCS04250G	299504	299590	014526	006752	006598	006598	299454	137.0
4	TCS04280G	299504	299591	014526	006753	006603	006605	299454	158.0
5	DCS05210G	299505	299592	014525	006754	006611	006606	299454	182.5
5	DCS05250G	299505	299592	014526	006754	006611	006608	299457	182.5
5	DCS05280G	299505	299592	014526	006754	006611	006610	299458	190.5
5	DCS05320G	299505	299592	014527	006754	006611	006611	299458	190.5
5	DCS05360G	299505	299592	014527	006755	006616	006618	299458	197.0
5	TCS05140G	299505	299592	014524	006752	006598	006592	299453	168.0
5	TCS05180G	299505	299592	014525	006752	006598	006594	299453	168.0
5	TCS05210G	299505	299592	014525	006752	006598	006596	299453	168.0
5	TCS05250G	299505	299592	014526	006752	006598	006598	299454	173.0
5	TCS05280G	299505	299592	014526	006753	006603	006605	299454	177.0
6	DCS06210G	299506	299592	014525	006754	006611	006606	299457	200.0
6	DCS06250G	299506	299592	014526	006754	006611	006608	299457	200.0
6	DCS06280G	299506	299592	014526	006754	006611	006610	299458	208.0
6	DCS06320G	299506	299592	014527	006754	006611	006611	299458	208.0
6	DCS06360G	299506	299592	014527	006755	006616	006618	299458	208.0
6	TCS06180G	299506	299592	014525	006752	006598	006594	299453	179.0

■ Refer to Table 12, page G3-34 for compatibility of various combinations of reducers and accessories.

◆ When using external backstops on sizes 7 through 12 reducers with scoops, see page G3-37 for UA and NA dimensions. Change out TL Bushing or Finish bore hub to fit smaller input shaft diameter of backstop reducer.

■ Sizes 1-3 discontinued. Remaining stock may be available.

FEATURES/BENEFITS
PAGE G3-3

NOMENCLATURE
PAGE G3-6

EASY SELECTION
PAGE G3-7

RELATED PRODUCTS
PAGE G3-55

MODIFICATIONS/ ACCESSORIES



Gearing Reference Guide

TORQUE-ARM II

TORQUE-ARM

MAXUM Concentric Reducer

TIGEAR-2

MAXUM Concentric Reducer SCOOP PACKAGES WITH GRID-LIGN COUPLINGS ■ ◆

MAXUM Size	Scoop Package Part Number	Side Plate	Bottom Plate	Motor Mounting Bolt Kit	Grid & Cover Assembly	Reducer Hub	Motor Hub	Coupling Guard Assy.	Scoop Package Weight (lbs.)
6	TCS06210G	299506	299592	014525	006752	006598	006596	299453	179.0
6	TCS06250G	299506	299592	014526	006752	006598	006598	299454	184.0
6	TCS06280G	299506	299592	014526	006753	006603	006605	299454	188.0
6	TCS06320G	299506	299592	014527	006754	006608	006611	299455	199.5
6	TCS06360G	299506	299592	014527	006755	006612	006618	299456	211.0
7	DCS07250G	299507	299592	014526	006755	006479	006612	299462	246.0
7	DCS07280G	299507	299592	014526	006755	006479	006614	299464	246.0
7	DCS07320G	299507	299592	014527	006755	006479	006616	299464	246.0
7	DCS07360G	299507	299592	014527	006755	006479	006618	299464	246.0
7	DCS07400G	299507	299593	014528	006756	006625	006627	304938	321.0
7	DCS07440G	299507	299593	014528	006757	006796	006802	304939	341.0
7	TCS07210G	299507	299592	014525	006753	006605	006601	299461	221.0
7	TCS07250G	299507	299592	014526	006753	006605	006603	299461	221.0
7	TCS07280G	299507	299592	014526	006753	006605	006605	299462	234.0
7	TCS07320G	299507	299592	014527	006754	006610	006611	299462	239.0
7	TCS07360G	299507	299592	014527	006755	006614	006618	299462	245.0
9	DCS09360G	299509	299594	014527	006756	006628	006623	299471	327.0
9	DCS09400G	299509	299595	014528	006756	006628	006627	304940	382.0
9	DCS09440G	299509	299595	014528	006757	006799	006802	304941	405.0
9	TCS09250G	299509	299594	014526	006754	006611	006608	299467	290.0
9	TCS09280G	299509	299594	014526	006754	006611	006610	299467	290.0
9	TCS09320G	299509	299594	014527	006754	006611	006611	299468	301.0
9	TCS09360G	299509	299594	014527	006755	006616	006618	299468	307.0
9	TCS09400G	299509	299595	014528	006756	006621	006627	299469	380.0
9	TCS09440G	299509	299595	014528	006757	006656	006802	299470	403.0
10	DCS10360G	299510	299594	014527	006757	006803	006804	304936	371.5
10	DCS10400G	299510	299595	014528	006757	006803	006798	304942	413.5
10	DCS10440G	299510	299595	014528	006757	006803	006802	304943	422.5
10	TCS10250G	299510	299594	014526	006755	006618	006612	299474	310.0
10	TCS10280G	299510	299594	014526	006755	006618	006614	299474	310.0
10	TCS10320G	299510	299594	014527	006755	006618	006616	299475	329.0
10	TCS10360G	299510	299594	014527	006755	006618	006618	299475	329.0
10	TCS10400G	299510	299595	014528	006756	006623	006627	299476	397.0
10	TCS10440G	299510	299595	014528	006757	006804	006802	299477	422.5
11	DCS11360G	299511	299594	014527	006757	006480	006804	304936	394.5
11	DCS11400G	299511	299595	014528	006757	006480	006798	304947	441.5
11	DCS11440G	299511	299595	014528	006757	006480	006802	304950	454.5
11	TCS11280G	299511	299594	014526	006755	006618	006614	299480	357.0
11	TCS11320G	299511	299594	014527	006755	006618	006616	299480	357.0
11	TCS11360G	299511	299594	014527	006755	006618	006618	299480	357.0
11	TCS11400G	299511	299595	014528	006756	006623	006627	299481	423.0
11	TCS11440G	299511	299595	014528	006757	006804	006802	299482	448.5
12	DCS12360G	299512	299594	014527	006757	006480	006804	304936	409.5
12	DCS12400G	299512	299595	014528	006757	006480	006798	299481	456.5
12	DCS12440G	299512	299595	014528	006757	006480	006802	304950	469.5
12	TCS12280G	299512	299594	014526	006755	006618	006614	299480	372.0
12	TCS12320G	299512	299594	014527	006755	006618	006616	299480	372.0
12	TCS12360G	299512	299594	014527	006755	006618	006618	299480	372.0
12	TCS12400G	299512	299595	014528	006756	006623	006627	299481	438.0
12	TCS12440G	299512	299595	014528	006757	006804	006802	299482	463.5

- Refer to Table 12, page G3-34 for compatibility of various combinations of reducers and accessories.
- ◆ When using external backstops on sizes 7 through 12 reducers with scoops, see page G3-37 for UA and NA dimensions. Change out TL Bushing or Finish bore hub to fit smaller input shaft diameter of backstop reducer.

FEATURES/BENEFITS PAGE G3-3	NOMENCLATURE PAGE G3-6	EASY SELECTION PAGE G3-7	RELATED PRODUCTS PAGE G3-55
--------------------------------	---------------------------	-----------------------------	--------------------------------

MODIFICATIONS/ ACCESSORIES



MAXUM Concentric Reducer

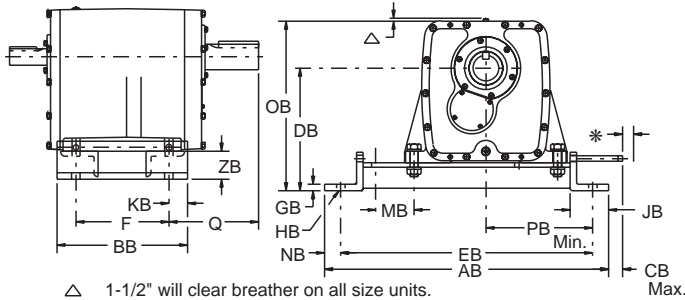

△ 1-1/2" will clear breather on all size units.

* Minimum distance required to remove adjusting stud.



SLIDE BASES

The MAXUM Reducer Slide Base positions the reducer, providing simplified installation and servicing of belt and chain drives. When a change in reducer position is desired, simply loosen reducer hold-down bolts and slide reducer

by using the adjusting screw provided. After desired belt or chain tension has been obtained, retighten reducer bolts and unit is ready to operate.

NOTE: For Slide Bases for MAXUM HD Baseplates, consult DODGE.

MAXUM REDUCER SLID BASES ■

Reducer Size	Part Numbers	AB	BB	CBG	DB	ED	F	GB	HB Bolts	JB
1	304627	23.25	9.00	2.88	9.05	21.25	6.00	0.50	1/2"	3.00
2	304628	24.25	10.25	2.97	9.75	22.25	7.13	0.50	5/8"	3.00
3	304629	26.75	11.25	2.97	11.25	24.75	7.75	0.50	3/4"	3.00
4	304630	30.88	13.25	3.11	14.10	28.13	9.00	0.75	7/8"	4.00
5	304631	32.63	13.75	3.11	14.46	29.88	10.00	0.75	1"	4.00
6	304632	35.38	15.50	3.22	16.16	32.63	11.30	0.75	1-1/8"	4.00
7	304633	44.44	20.50	2.25	19.18	39.44	14.70	1.00	11/4"	6.00
9	304635	50.38	24.00	2.25	22.50	45.38	18.19	1.00	11/2"	6.00
10	304636	49.94	26.00	3.34	24.63	44.94	20.25	1.00	11/2"	6.00
11	304637	53.31	26.25	3.34	27.00	48.31	20.38	1.00	13/4"	6.00
12	304638	56.16	26.88	3.34	29.63	51.16	21.00	1.00	13/4"	6.00

Reducer Size	KB	MB	NB	OB	PB Min.	Q	ZB	★	Wt. (lbs.)
1	1.50	4.50	1.00	12.89	8.36	6.72	2.75	3/4"	45
2	1.56	4.50	1.00	13.75	8.85	7.46	2.75	3/4"	48
3	1.75	4.50	1.00	16.13	10.10	8.78	2.75	3/4"	54
4	2.13	5.00	1.38	18.97	11.55	9.45	4.50	1"	95
5	1.88	5.00	1.38	19.94	12.42	10.75	4.50	1"	100
6	2.09	5.00	1.38	22.66	13.80	11.91	4.50	1"	112
7	2.88	6.00	2.50	26.69	16.72	14.09	4.38	11/4"	245
9	2.91	6.00	2.50	31.76	19.69	17.49	4.38	11/4"	300
10	2.88	7.00	2.50	34.68	18.94	16.67	6.25	11/4"	370
11	2.94	7.00	2.50	38.36	20.66	17.93	6.25	11/4"	380
12	2.94	7.00	2.50	42.04	22.08	18.17	6.25	11/4"	410

■ Refer to Table 12, page G3-34 for compatibility of various combinations of reducers and accessories.

■ Sizes 1-3 discontinued. Remaining stock may be available.

FEATURES/BENEFITS PAGE G3-3	NOMENCLATURE PAGE G3-6	EASY SELECTION PAGE G3-7	RELATED PRODUCTS PAGE G3-55
--------------------------------	---------------------------	-----------------------------	--------------------------------



MAXUM Concentric Reducer

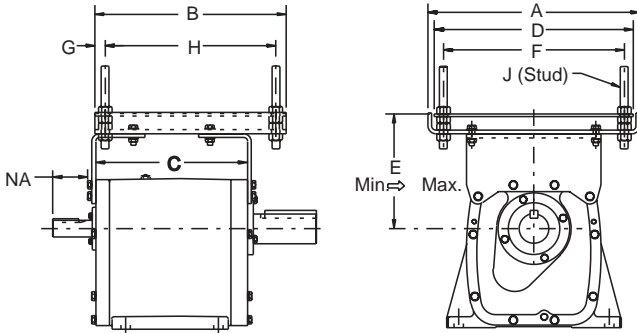

TOP MOTOR MOUNTS

The MAXUM Motor Mount is a rugged all steel unit which requires no drilling or foundation. It bolts directly to the top of the MAXUM Concentric Shaft Reducer. Each mount

accommodates a wide variety of NEMA AC motor frames. For initial belt installation the adjusting screws can be set at a minimum position which offers adequate future V-belt adjustment.

TOP MOTOR MOUNTS SIZES 1-6 ■

Motor Mount Size	Motor Mount Part Number	Wt.	MAXUM Size	To Accommodate NEMA Motor Frame Sizes ★	A	B	C Nom.	D	E ▲	
									Min	Max
MAXUM 1-2	299529	80	1	143 thru 215	18.63	17.00	10.62	17.50	9.27	12.86
			2	143 thru 256			11.90		9.45	13.04
MAXUM 3-4	299530	107	3	143 thru 286	20.50	18.50	12.77	19.25	9.89	13.60
			4	143 thru 326			14.67		9.77	13.48
MAXUM 5-6	299531	149	5	182 thru 365	22.50	19.00	16.20	21.25	10.78	15.73
			6	182 thru 365			17.77		11.78	16.73

Motor Mount Size	F	G	H	J-Stud		NA	
				Dia.	Lgth.	Double	Triple
MAXUM 1-2	15.50	1.00	14.25	3/4-10	8	3.05	3.05
MAXUM 3-4	17.50	1.00	16.50	3/4-10	8	3.37	3.37
MAXUM 5-6	19.25	1.13	16.50	1-8	9	4.50	3.41

★ Select motor size to suit horsepower requirements. See table below for V-belt center distances.

▲ Provides for V-belt adjustment.

V-BELT CENTER DISTANCES FOR MAXUM MOTOR MOUNTS

Motor Mount Size	MAXUM Size	Center Distances for NEMA Motor Mounts													
		140		180		210		250		280		320		360	
		Min.	Max.	Min.	Max.	Min.	Max.	Min.	Max.	Min.	Max.	Min.	Max.	Min.	Max.
MAXUM 1-2	1	13.27	16.36	14.27	17.36	15.02	18.11								
	2	13.45	16.54	14.45	17.54	15.20	18.29	16.20	19.29						
MAXUM 3-4	3	13.89	17.10	14.89	18.10	15.64	18.85	16.64	19.85	17.39	20.60				
	4	13.77	16.98	14.77	17.98	15.52	18.73	16.52	19.73	17.27	20.48	18.27	21.48		
MAXUM 5-6	5			15.78	20.23	16.53	20.98	17.53	21.98	18.28	22.73	19.28	23.73	20.28	24.73
	6			16.78	21.23	17.53	21.98	18.53	22.98	19.28	23.73	20.28	24.73	21.28	25.73

■ Refer to Table 12, page G3-34 for compatibility of various combinations of reducers and accessories.

■ Sizes 1-3 discontinued. Remaining stock may be available

FEATURES/BENEFITS PAGE G3-3	NOMENCLATURE PAGE G3-6	EASY SELECTION PAGE G3-7	RELATED PRODUCTS PAGE G3-55
--------------------------------	---------------------------	-----------------------------	--------------------------------

MODIFICATIONS/ ACCESSORIES



MAXUM Concentric Reducer

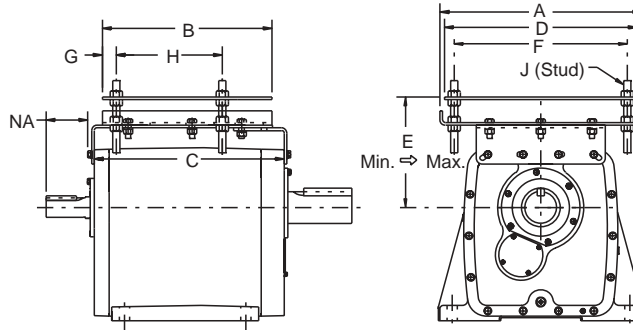

TOP MOTOR MOUNTS SIZES 7-12 ■

Motor Mount Size	Motor Mount Part Number	Wt.	MAXUM Size	To Accommodate NEMA Motor Frame Sizes ★	A	B	C Nom.	D	E ▲	
									Min	Max
MAXUM 7	299532	257	7	213 thru 445	28.50	24.00	23.69	27.25	13.41	18.91
MAXUM 9	299534	278	9	213 thru 445	28.50	24.00	28.45	27.25	15.53	21.03
MAXUM 10	299535	283	10	254 thru 445	28.50	24.00	28.82	27.25	16.59	22.09
MAXUM 11	299536	289	11	284 thru 445	28.50	24.00	30.51	27.25	19.37	24.87
MAXUM 12	299537	301	12	284 thru 445	28.50	24.00	30.57	27.25	20.37	25.87

Motor Mount Size	F	G	H	J-Stud		NA		
				Dia.	Lgth.	Double	Triple	
							31.39-70.62	86.50-194.6
MAXUM 7	24.25	2.00	15.00	1-8	101/4	5.41	3.77	3.77
MAXUM 9	24.25	2.00	15.00	1-8	101/4	6.15	4.23	4.23
MAXUM 10	24.25	2.00	15.00	1-8	101/4	6.23	5.90	4.78
MAXUM 11	24.25	2.00	15.00	1-8	101/4	5.33	5.37	4.18
MAXUM 12	24.25	2.00	15.00	1-8	101/4	5.33	5.37	4.18

- ★ Select motor size to suit horsepower requirements. See table below for V-belt center distances.
- ▲ Provides for V-belt adjustment.

V-BELT CENTER DISTANCES FOR MAXUM MOTOR MOUNTS

Motor Mount Size	MAXUM Size	Center Distances for NEMA Motor Mounts													
		210		250		280		320		360		400		440	
		Min.	Max.	Min.	Max.	Min.	Max.	Min.	Max.	Min.	Max.	Min.	Max.	Min.	Max.
MAXUM 7	7	19.66	24.16	20.66	25.16	21.41	25.91	22.41	26.91	23.41	27.91	24.41	28.91	25.41	29.91
MAXUM 9	9	21.78	26.28	22.78	27.28	23.53	28.03	24.53	29.03	25.53	30.03	26.53	31.03	27.53	32.03
MAXUM 10	10			23.84	28.34	24.59	29.09	25.59	30.09	26.59	31.09	27.59	32.09	28.59	33.09
MAXUM 11	11					27.73	31.87	28.37	32.87	29.37	33.87	30.37	34.87	31.37	35.87
MAXUM 12	12					28.37	32.87	29.37	33.87	30.37	34.87	31.37	35.87	32.37	36.87

- Refer to Table 12, page G3-34 for compatibility of various combinations of reducers and accessories.



MAXUM Concentric Reducer

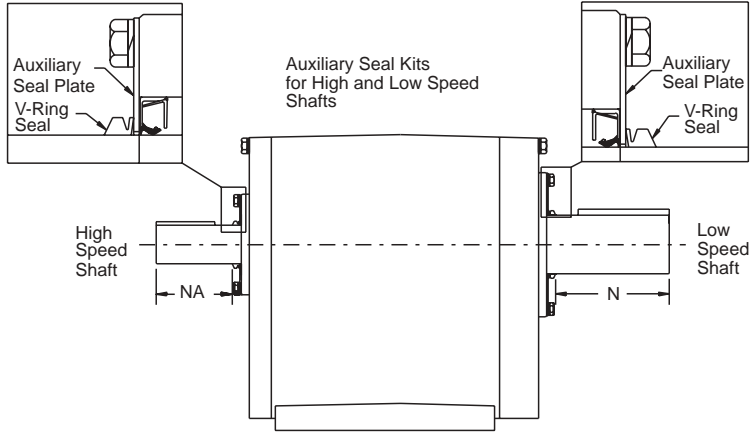

AUXILIARY SEAL KITS

Where exposure to dust, moisture or other types of contamination is a potential problem, the optional MAXUM Reducer Auxiliary Seal Kit is recommended.

Kits consist of auxiliary seal plates and V-ring seals for both high speed and low speed shafts. The seal plate protects the seal from accidental damage and the V-ring provides extra sealing protection from external contaminants. Kits mount with no additional drilling and tapping.

Filter Breathers*

Reduced Size	Part Number	Housing Hole Dimensions
DCR/TCR 1-4	430048	3/8 - 18 NPSF
DCR/TCR 5-6	430049	1/2 - 14 NPSF
DCR/TCR 7-12	430049 ●	1-11 NPSF

* Breathers fit all reducer ratios

- Order 1" x 1/2" adapter, part number A45631 for mounting Filter Breather to reducer housing.

Unit Size	Ratios	Part	NA	N
		Number		
DCR/TCR 1	2.25-194.6	299701	2.86	3.3
DCR/TCR 2	2.25-194.6	299699	2.86	4.05
DCR/TCR 3	2.25-194.6	300305	3.23	5.05
DCR/TCR 4	2.25-194.6	300302	3.23	5.45
DCR 5	2.25-25.63	300906	4.31	6.45
TCR 5	31.39-194.6	300903	3.23	6.45
DCR 6	2.25-25.63	300904	4.31	7.25
TCR 6	31.39-194.6	301204	3.23	7.25
DCR 7	5.06-25.63	301504	5.25	7.73
TCR 7	31.39-194.6	301504	3.77*	7.73
DCR 9	5.06-25.63	302104	6.00	10.46
TCR 9	31.39-194.6	302104	4.23*	10.46
DCR 10	5.06-25.63	302408	6.06	10.79
TCR 10	31.39-70.62	302408	5.90*	10.79
TCR 10	86.50-194.6	302408	4.78*	10.79
DCR 11	5.06-25.63	302711	5.33*	11.34
TCR 11	31.39-70.62	302711	5.37*	11.34
TCR 11	86.50-194.6	302711	4.18*	11.34
DCR 12	5.06-25.63	302713	5.33*	11.84
TCR 12	31.39-70.62	302713	5.37*	11.84
TCR 12	86.50-194.6	302713	4.18*	11.84

* NA dimensions are the same with or without auxiliary seals.

■ Sizes 1-3 discontinued. Remaining stock may be available.

FEATURES/BENEFITS PAGE G3-3	NOMENCLATURE PAGE G3-6	EASY SELECTION PAGE G3-7	RELATED PRODUCTS PAGE G3-55
--------------------------------	---------------------------	-----------------------------	--------------------------------



MAXUM Concentric Reducer

MODIFICATIONS OR ASSEMBLY FOR MAXUM CONCENTRIC REDUCERS

CONSULT DODGE FOR THESE ASSEMBLIES, ACCESSORIES, AND MODIFICATIONS

- | | |
|-----|--|
| 1. | MAXUM REDUCER MODIFIED FOR INCLINED OR VERTICAL SHAFT, EXCEEDING 10°. ADVISE IF INPUT SHAFT UP OR DOWN. |
| 2. | MAXUM REDUCER WITH AUXILIARY SEALS INSTALLED |
| 3. | MAXUM REDUCER WITH COOLING FAN INSTALLED |
| 4. | MAXUM REDUCER WITH EXTERNAL BACKSTOP ASSEMBLY INSTALLED. (SPECIFY DIRECTION OF ROTATION ON ORDER.) |
| 5. | MAXUM REDUCER AND ACCESSORIES PACKAGED FOR SHIPMENT ON ONE PALLET. |
| 6. | MAXUM SCOOP PACKAGE ASSEMBLED WITH RELIANCE MOTOR. |
| 7. | MAXUM HD (HEAVY DUTY) BASE PLATE PACKAGE ASSEMBLED WITH RELIANCE MOTOR. |
| 8. | MAXUM REDUCER WITH SPECIAL BEARING ADJUSTMENT |
| 9. | MAXUM REDUCER PREPARED FOR LONG-TERM STORAGE |
| 10. | MAXUM REDUCER ASSEMBLED WITH FLUID COUPLING OR FLUID DRIVE. |
| 11. | MAXUM REDUCER OPTIONS FOR HARSH ENVIRONMENTS
REDUCER PAINT OPTIONS
OPTIONAL BREATHERS
OIL SIGHT & WINDOW GAUGES
SPECIALTY LUBRICANTS
OIL SUMP HEATERS
STANDARD OIL SEAL REPLACEMENT KITS |

RELATED PRODUCTS



Gearing Reference Guide

MAXUM Concentric Reducer PARA-FLEX COUPLING SELECTION ◆

RED. SIZE	RED. INPUT SHFT. DIA.	Coupling Sizes Used on Various HP A-C Motors @ 1750 RPM ■										
		1	1-1/2	2	3	5	7-1/2	10	15	20	25	30
		143T (7/8)	145T (7/8)	145T (7/8)	182T (1-1/8)	184T (1-1/8)	213T (1-3/8)	215T (1-3/8)	254T (1-5/8)	256T (1-5/8)	284T (1-7/8)	286T (1-7/8)
DCR 1	1-3/8	PX60	PX60	PX60	PX60	PX60	PX60	PX60				
TCR 1	1-3/8	PX60	PX60	PX60	PX60	PX60						
DCR 2	1-3/8	PX60	PX60	PX60	PX60	PX60	PX60	PX60	PX60			
TCR 2	1-3/8	PX60	PX60	PX60	PX60	PX60	PX60	PX60				
DCR 3	1-5/8	PX60FB	PX60FB	PX60FB	PX70	PX70	PX70	PX70	PX70	PX70	PX80	PX80
TCR 3	1-5/8	PX60FB	PX60FB	PX60FB	PX70	PX70	PX70	PX70	PX70			
DCR 4	1-5/8	PX60FB	PX60FB	PX60FB	PX70	PX70	PX70	PX70	PX70	PX70	PX80	PX80
TCR 4	1-5/8	PX60FB	PX60FB	PX60FB	PX70	PX70	PX70	PX70	PX70	PX70	PX80	
DCR 5	2-1/8				PX80	PX80	PX80	PX80	PX80	PX80	PX80	PX80
TCR 5	1-5/8	PX60FB	PX60FB	PX60FB	PX70	PX70	PX70	PX70	PX70	PX70	PX80	PX80
DCR 6	2-1/8						PX80	PX80	PX80	PX80	PX80	PX80
TCR 6	1-5/8				PX70	PX70	PX70	PX70	PX70	PX70	PX80	PX80
DCR 7	2-5/8								PX90	PX90	PX90	PX90
TCR 7	1-7/8						PX80	PX80	PX80	PX80	PX80	PX80
DCR 9	3									PX80	PX80	PX80
TCR 9	2-1/8											
DCR 10	3-1/2									PX90	PX90	PX90
TCR 10	2-3/8											
DCR 11	3-3/4									PX90	PX90	PX90
TCR 11	2-3/8											
DCR 12	3-3/4										PX90	PX90
TCR 12	2-3/8											

TORQUE-ARM II

TORQUE-ARM

RED. SIZE	RED. INPUT SHFT. DIA.	Coupling Sizes Used on Various HP A-C Motors @ 1750 RPM ■								
		40	50	60	75	100	125	150	200	250
		324T (2-1/8)	326T (2-1/8)	364T (2-3/8)	365T (2-3/8)	405T+ (2-7/8)	444T+ (3-3/8)	445T+ (3-3/8)	447T+ (3-3/8)	449T+ (3-3/8)
DCR 4	1-5/8	PX80	PX80							
TCR 4	1-5/8									
DCR 5	2-1/8	PX80	PX80	PX90	PX90					
TCR 5	1-5/8									
DCR 6	2-1/8	PX80	PX80	PX90	PX90					
TCR 6	1-5/8	PX80	PX80	PX90	PX90					
DCR 7	2-5/8	PX90	PX90	PX90	PX90	PX120	PX140	PX140	PX140	
TCR 7	1-7/8	PX80	PX80	PX90	PX90					
DCR 9	3	PX120	PX120	PX120	PX120	PX120X	PX140	PX140	PX140	PX140
TCR 9	2-1/8	PX80	PX80	PX90	PX90	PX12	PX140	PX140		
DCR 10	3-1/2			PX140	PX140	PX140	PX140	PX140	PX140	
TCR 10	2-3/8	PX90	PX90	PX90	PX90	PX120	PX140	PX140	PX140	PX140
DCR 11	3-3/4			PX140	PX140	PX140	PX140	PX140	PX140	PX140
TCR 11	2-3/8	PX90	PX90	PX90	PX90	PX120	PX140	PX140	PX140	PX140
DCR 12	3-3/4			PX140	PX140	PX140	PX140	PX140	PX140	PX140
TCR 12	2-3/8	PX90	PX90	PX90	PX90	PX120	PX140	PX140	PX140	PX140

MAXUM Concentric Reducer

- Frame size reference with motor shaft diameter shown in parentheses
- ◆ For Backstop reducer, size 7 thru 12, see UA and NA dimension page G3-37; change out TL Bushing or Finish bore hub to fit smaller input shaft diameter of Backstop reducer.
- + TEFC-XE Frame, Energy Efficient Motors*
- Sizes 1-3 discontinued. Remaining stock may be available.

TIGEAR-2

FEATURES/BENEFITS PAGE G3-3	NOMENCLATURE PAGE G3-6	EASY SELECTION PAGE G3-7	SELECTION/DIMENSIONS PAGE G3-23
--------------------------------	---------------------------	-----------------------------	------------------------------------

RELATED PRODUCTS



MAXUM Concentric Reducer GRID-LIGN COUPLING SELECTION ◆

RED. SIZE	RED. INPUT SHFT. DIA.	Coupling Sizes Used on Various HP A-C Motors @ 1750 RPM ■											
		1	1-1/2	2	3	5	7-1/2	10	15	20	25	30	
		143T (7/8)	145T (7/8)	145T (7/8)	182T (1-1/8)	184T (1-1/8)	213T (1-3/8)	215T (1-3/8)	254T (1-5/8)	256T (1-5/8)	284T (1-7/8)	286T (1-7/8)	
DCR 1	1-3/8	1030T10	1030T10	1030T10	1030T10	1030T10	1030T10	1030T10					
TCR 1	1-3/8	1030T10	1030T10	1030T10	1030T10	1030T10							
DCR 2	1-3/8	1030T10	1030T10	1030T10	1030T10	1030T10	1030T10	1030T10	1040T10	1040T10			
TCR 2	1-3/8	1030T10	1030T10	1030T10	1030T10	1030T10	1030T10	1030T10					
DCR 3	1-5/8	1040T10	1040T10	1040T10	1040T10	1040T10	1040T10	1040T10	1040T10	1040T10	1050T10	1050T10	
TCR 3	1-5/8	1040T10	1040T10	1040T10	1040T10	1040T10	1040T10	1040T10	1040T10				
DCR 4	1-5/8	1040T10	1040T10	1040T10	1040T10	1040T10	1040T10	1040T10	1040T10	1040T10	1040T10	1050T10	1050T10
TCR 4	1-5/8	1040T10	1040T10	1040T10	1040T10	1040T10	1040T10	1040T10	1040T10	1040T10	1040T10	1050T10	
DCR 5	2-1/8	1040T10	1040T10	1040T10	1060T10	1060T10	1060T10	1060T10	1060T10	1060T10	1060T10	1060T10	1060T10
TCR 5	1-5/8				1040T10	1040T10	1040T10	1040T10	1040T10	1040T10	1040T10	1050T10	1050T10
DCR 6	2-1/8						1060T10	1060T10	1060T10	1060T10	1060T10	1060T10	1060T10
TCR 6	1-5/8				1040T10	1040T10	1040T10	1040T10	1040T10	1040T10	1040T10	1050T10	1050T10
DCR 7	2-5/8						1050T10	1050T10	1070T10	1070T10	1070T10	1070T10	1070T10
TCR 7	1-7/8								1050T10	1050T10	1050T10	1050T10	1050T10
DCR 9	3												
TCR 9	2-1/8								1060T10	1060T10	1060T10	1060T10	1060T10
DCR 10	3-1/2									1070T10	1070T10	1070T10	1070T10
TCR 10	2-3/8												
DCR 11	3-3/4									1070T10	1070T10	1070T10	1070T10
TCR 11	2-3/8									1070T10	1070T10	1070T10	1070T10
DCR 12	3-3/4												
TCR 12	2-3/8											1070T10	1070T10

RED. SIZE	RED. INPUT SHFT. DIA.	Coupling Sizes Used on Various HP A-C Motors @ 1750 RPM ■								
		40	50	60	75	100	125	150	200	250
		324T (2-1/8)	326T (2-1/8)	364T (2-3/8)	365T (2-3/8)	405T+ (2-7/8)	444T+ (3-3/8)	445T+ (3-3/8)	447T+ (3-3/8)	449T+ (3-3/8)
DCR 4	1-5/8	1060T10	1060T10							
TCR 4	1-5/8									
DCR 5	2-1/8	1060T10	1060T10	1070T10	1070T10					
TCR 5	1-5/8									
DCR 6	2-1/8	1060T10	1060T10	1070T10	1070T10					
TCR 6	1-5/8	1060T10	1060T10	1070T10						
DCR 7	2-5/8	1070T10	1070T10	1070T10	1070T10	1080T10	1090T10	1090T10	1090T10	1090T10
TCR 7	1-7/8	1060T10	1060T10	1070T10	1070T10					
DCR 9	3	1080T10	1080T10	1080T10	1080T10	1080T10	1090T10	1090T10	1090T10	1090T10
TCR 9	2-1/8	1060T10	1060T10	1070T10	1070T10	1080T10	1090T10	1090T10		
DCR 10	3-1/2	1070T10	1070T10	1090T10	1090T10	1090T10	1090T10	1090T10	1090T10	1090T10
TCR 10	2-3/8			1070T10	1070T10	1080T10	1090T10	1090T10	1090T10	1090T10
DCR 11	3-3/4	1070T10	1070T10	1090T10	1090T10	1090T10	1090T10	1090T10	1090T10	1090T10
TCR 11	2-3/8			1070T10	1070T10	1080T10	1090T10	1090T10	1090T10	1090T10
DCR 12	3-3/4	1070T10	1070T10	1090T10	1090T10	1090T10	1090T10	1090T10	1090T10	1090T10
TCR 12	2-3/8			1070T10	1070T10	1080T10	1090T10	1090T10	1090T10	1090T10

■ Frame size reference with motor shaft diameter shown in parentheses

◆ For Backstop reducer, size 7 thru 12, see UA and NA dimension page G3-37; change out TL Bushing or Finish bore hub to fit smaller input shaft diameter of Backstop reducer.

+ TEFC-XE Frame, Energy Efficient Motors*

■ Sizes 1-3 discontinued. Remaining stock may be available.

FEATURES/BENEFITS PAGE G3-3	NOMENCLATURE PAGE G3-6	EASY SELECTION PAGE G3-7	SELECTION/DIMENSIONS PAGE G3-23
--------------------------------	---------------------------	-----------------------------	------------------------------------



MAXUM Concentric Reducer HORSEPOWER METHOD OF SELECTION

Step 1: Determine Service Factor - See Table 2 for electric motor, hydraulic motor, steam turbine or gas turbine driven applications operating up to 10 hours per day or over 10 hours per day. If the application is engine driven, refer to Table 1 to convert the service factor obtained from Table 2 to the service factor required for engine driven applications. Service factor recommendations are minimum. (For extreme shock or high energy loads which must be absorbed, as when stalling, or for power sources not listed, consult DODGE for special consideration.)

Step 2: Calculate Equivalent Horsepower - Multiply the actual horsepower to be transmitted by the service factor obtained from Step 1.

CAUTION: Instantaneous gear loading is limited to 200% of the reducer rating. Do not allow starting load or other peak loads to exceed this value. Failure to observe this precaution could result in damage to, or destruction of, the equipment.

Step 3: Calculate Required Ratio - Divide the high speed shaft rpm by the low speed shaft rpm.

Step 4: Determine Unit Size and Ratio - Refer to the horsepower tables on pages G3-60, G3-62 and G3-66. From the high speed input shaft rpm in the left hand column and desired ratio and output speed in the next two columns, trace right into the table and find the horsepower rating equal to or greater than the equivalent horsepower obtained from Step 2. (When the required input speed falls between those tabulated, use straight line interpolation to determine the unit rating.)

Step 5: Check Thermal Ratings - When the horsepower rating of the reducer selected from Step 4 falls in the shaded area, compare the actual horsepower required (without service factor) with the thermal horsepower capacity by referring to the thermal horsepower rating tables on pages G3-68 and G3-69. If the actual transmitted horsepower exceeds the thermal capacity, an auxiliary cooling fan or a heat exchanger may be added to provide additional thermal capacity or a larger reducer may be required.

NOTE: On applications where the continuous running time never exceeds three hours and the idle time is equal to or greater than the running time, thermal limitations can be disregarded and the unit operated at loads up to the listed mechanical rating modified by applicable service factors.

Step 6: Check Overhung and Thrust Loads - Refer to the Overhung Load explanation on page G3-59. Overhung loads may be imposed on the input or output shafts when connected by means other than a coupling. If overhung loads are present, refer to the method and example for calculating overhung loads.

External thrust loads may exist in applications such as agitators, mixers and similar equipment. Calculate the direction and magnitude of the thrust as well as the direction of the shaft rotation and consult DODGE.

Step 7: Variable Speed Applications - When mounting variable speed AC or DC motors, consult the guidelines on pages G3-81 and G3-82.

Step 8: Check Dimensions - See applicable pages for dimensions, weights, part numbers and instructions on how to order.

TORQUE METHOD OF SELECTION

Determine service factor, equivalent torque and unit size using the same steps as outlined above for the horsepower method, except in Step 4 refer to the torque tables on pages G3-61, G3-64 and G3-67. Interpolate for speeds not listed. When ratings are shown in the shaded area, convert the required torque without service factor to horsepower by using the following formula:

$$\text{Horsepower} = \frac{\text{Torque (lb-in)} \times \text{Low Speed Shaft rpm}}{63025}$$

and compare the computed results with the thermal capacities shown in Table 20, page G3-68 and G3-69.

EXAMPLES OF SELECTION

Horsepower Method

A centrifugal pump operating at 230 rpm is driven by a 200 horsepower 1750 rpm motor. The duty cycle is 24 hours per day. Both the input and output reducer shafts are coupling connected.

Step 1: Determine Service Factor - From Table 2, Service Factors, locate "Pumps - Centrifugal" and under the column headed "10+ Hrs/Day Service" find the Service Factor which is 1.25.

Step 2: Calculate Equivalent Horsepower - Multiply the motor horsepower by the service factor (200 x 1.25 = 250) to get the equivalent horsepower of 250.

Step 3: Calculate Required Ratio - Divide the high speed shaft rpm by the low speed shaft rpm (1750 / 230 = 7.6) to get the required ratio of 7.6:1.

FEATURES/BENEFITS PAGE G3-3	NOMENCLATURE PAGE G3-6	EASY SELECTION PAGE G3-7	SELECTION/DIMENSIONS PAGE G3-23
--------------------------------	---------------------------	-----------------------------	------------------------------------

ENGINEERING/TECHNICAL



MAXUM Concentric Reducer

Step 4: Determine Unit Size and Ratio - Locate the horsepower table for 1750 high speed shaft rpm (Table 14, page G3-60). Trace down the ratio column to the closest nominal ratio to the 7.6:1 required ratio and find 7.59:1 ratio. Trace to the right until the horsepower equals or exceeds the calculated equivalent horsepower of 250 and find 323 horsepower listed under a MAXUM size 7 reducer.

Step 5: Check Thermal Ratings - Because the 323 mechanical horsepower rating for the MAXUM size 7 reducer fell in the shaded area, the thermal capacity must be checked. Refer to the thermal horsepower rating tables on page G3-68. Locate the table for 1750 high speed shaft rpm and find the thermal ratings for the MAXUM size 7 reducer. Note that the thermal rating without a fan is 150 horsepower and that the thermal rating with a fan is 273 horsepower. When a dash (-) is shown, the dash means that the thermal capacity exceeds the mechanical capacity. Since the actual transmitted horsepower of 200 exceeds the 150 thermal rating without a fan, an auxiliary cooling fan is required.

Step 6: Check Overhung and Thrust Loads - Since both shafts are coupling connected, overhung or thrust loads are not applied.

Step 7: Variable Speed Applications - Since this is a constant speed application, variable speed does not apply.

Step 8: Check Dimensions - Refer to the specifications/dimensions page G3-29 for DODGE MAXUM size 7 reducers. The part number for the reducer is **299140** and for the auxiliary cooling fan is **299523**. The exact ratio of the reducer is given in Table 24, page G3-74 and is 7.527:1.

TORQUE METHOD

Running 10 hours a day, a scum breaker for a sewage disposal system requires 51,350 lb-in of torque at 230 rpm and has an overhung load of 6,710 pounds on the low speed shaft. The overhung load is located 4 inches out from the reducer on the usable shaft extension. The motor speed is 1170 rpm and is coupling connected.

Step 1: Determine Service Factor - From Table 2, Service Factors, locate "Sewage Disposal - Scum Breakers" and under the column headed "3-10 Hrs/Day Service" locate the service factor which is 1.50.

Step 2: Calculate Equivalent Torque - Multiply the system torque of 51,350 by the service factor of 1.50

(51,350 x 1.50 = 77,025) to get 77,025 lb-in equivalent torque.

Step 3: Calculate Required Ratio - Divide the high speed shaft rpm by the low speed shaft rpm (1170 / 230 = 5.09) to get the required ratio of 5.09:1.

Step 4: Determine Unit Size and Ratio - Locate the torque table for 1170 high speed shaft rpm (Table 17, page G3-64). Trace down the ratio column to the closest nominal ratio to the 5.09:1 required ratio and find 5.06:1 ratio. Trace to the right until the torque equals or exceeds the calculated equivalent torque of 77,025 and find 77,700 listed under a MAXUM size 7 reducer.

Step 5: Check Thermal Ratings - Because the 77,700 mechanical rating falls in the shaded area, the thermal ratings must be checked. First, convert the required torque without service factor (51,350) to horsepower at 230 rpm as follows:

$$\text{Horsepower} = \frac{510350 \times 230}{63025} = 187 \text{ hp}$$

Locate the table for the thermal horsepower ratings at 1170 high speed shaft rpm and find the MAXUM size 7 reducer with a 5.06 ratio. Since the 187 calculated horsepower exceeds the thermal rating shown without a fan, an auxiliary cooling fan is required.

Step 6: Check Overhung and Thrust Loads - An overhung load of 6,710 pounds is on the low speed shaft. It must first be adjusted for its position on the shaft. Turn to Table 22, page G3-71 load location factors for low speed shafts and locate the 4 inch distance in the left hand column. Under the MAXUM 7 column find the load location factor of 1.06. Multiply the 6,710 overhung load by this factor (6,710 x 1.06 = 7,113) to get an equivalent overhung load of 7,113 pounds. Now turn to the output shaft overhung load Table 24, page G3-74 and locate 230 low speed shaft rpm in the left column. Trace right to the MAXUM size 7 reducer and find the overhung load capacity of 7,480 pounds. Since the capacity exceeds the equivalent overhung load, the selection is acceptable.

Step 7: Variable Speed Applications - Since this is a constant speed application, variable speed does not apply.

Step 8: Check Dimensions - Refer to the specifications/dimensions page G3-29 for DODGE MAXUM size 7 reducers. The part number for the reducer is **299138** and for the auxiliary cooling fan is **299523**. The exact ratio of the reducer is given in Table 25 and is 5.065:1.

FEATURES/BENEFITS PAGE G3-3	NOMENCLATURE PAGE G3-6	EASY SELECTION PAGE G3-7	SELECTION/DIMENSIONS PAGE G3-23
--------------------------------	---------------------------	-----------------------------	------------------------------------



MAXUM Concentric Reducer THRUST AND OVERHUNG LOADS- HOW TO CALCULATE

Thrust Loads as defined here are external axial forces applied to the input or output shafts. They may exist in applications such as agitators, mixers and similar equipment. Calculate the direction and magnitude of the thrust load, determine the direction of shaft rotation and consult DODGE.

Overhung Loads as defined here are external radial forces applied to the input or output shafts. They may occur in any angular position and at any distance out on the shaft from the reducer. Overhung loads may be calculated by the use of the following formula:

$$OHL = \frac{126,000 \times hp \times Fc \times Lf}{PD \times rpm}$$

- Where:
- OHL = Overhung Load (lbs.).
 - hp = Horsepower.
 - Fc = Load Connection Factor.
(See Table 13 below)
 - Lf = Load Location Factor.
(See Table 23 for High Speed Shafts)
(See Table 24 for Low Speed Shafts)
 - PD = Pitch Diameter of the Item Mounted on the Shaft (inches).
 - rpm = Speed of Shaft with Overhung Load on it in Revolutions Per Minute.
(Interpolate for shaft speeds not listed)

Use the above formula to calculate the overhung load on the shaft. Compare the calculated OHL results with the values published for the reducer shaft and condition. If the calculated OHL results exceed the published values, consult DODGE or consider a larger size reducer.

Location of Load Centerline - To minimize the affects of overhung loads and to increase bearing life, the centerline of the overhung load should always be located as close to the reducer oil seal as possible. For many applications the unit will accommodate more overhung load than is published. Overhung load ratings have been established for the most unfavorable combination of conditions that will be encountered.

Overhung Loads - Examples

High Speed Shaft Example - A MAXUM size 4 reducer with a 47.08:1 ratio is driven by a 1750 rpm 7 1/2 hp electric motor through a set of V-Belts at 870 rpm of the high speed shaft. The V-Belt drive consists of a 4.0" PD driver (2A3.6B4.0-1610) and a 8.6" PD driven sheave (2A8.2B8.6-2517). The driven sheave is mounted as close to the reducer oil seal as possible while allowing 1/4" for a guard thereby making the centerline of the belt pull 1.125" out from the reducer on the high speed shaft.

High Speed Shaft Calculation - Using the OHL equation previously given and substituting for the values as follows:

- hp = 7.5 (Motor Horsepower)
- Fc = 1.5 (From Table 13 for V-Belts)
- Lf = 0.975 (From Table 21 for MAXUM size 4 at 1.125,)
- PD = 8.6 (Driven sheave pitch diameter)
- rpm = 870 (High speed shaft rpm)

$$OHL = \frac{126,000 \times 7.5 \times 1.5 \times 0.975}{8.6 \times 870} = 185 \text{ pounds}$$

Turn to Table 23, High Speed Shaft Overhung Load, and in the left hand column locate 870 rpm and in the ratio column locate the 47.08 ratio. Trace right to the MAXUM size 4 and note that the High Speed Shaft Overhung Load capacity is 540 pounds. Since the 540 pound capacity exceeds the calculated overhung load of 185 pounds, the overhung load capacity is acceptable.

Low Speed Shaft Example - A MAXUM size 6 reducer is used to drive a uniformly loaded belt conveyor 24 hours per day. The reducer is driven by a 50 hp, 1750 rpm, electric motor coupled to the high speed shaft. The low speed shaft is rotating at 83.6 rpm and has a 160BTL26-3535 single strand sprocket with an oil tight chain casing mounted on it. The sprocket has a pitch diameter of 16.592 inches and the centerline of the teeth is located 4 inches out on the shaft.

Low Speed Calculation - Using the OHL equation previously given and substituting for the values as follows:

- hp = 50.0 (Motor Horsepower)
- Fc = 1.0 (From Table 13 for Sprockets)
- Lf = 1.11 (From Table 22 for MAXUM size 6 at 4,)
- PD = 16.592 (Driving sprocket pitch diameter)
- rpm = 83.6 (Low speed shaft rpm)

$$OHL = \frac{126,000 \times 50.0 \times 1.0 \times 1.11}{16.592 \times 83.6} = 5041 \text{ pounds}$$

Turn to Table 24, page G3-74, Low Speed Shaft Overhung Load, and in the left hand column locate the low speed shaft speed of 83.6 rpm. Trace right to the MAXUM size 6 and note that the low speed shaft overhung load capacity is 8250 pounds. Since the 8025 pound capacity exceeds the calculated overhung load of 5041 pounds, the overhung load capacity is acceptable.

Table 13: Load Connection Factors - Fc

Drive Type	Fc
Roller Chain Sprocket	1.0
Machined Pinion or Gear	1.25
Synchronous Belt	1.3
V-Belt	1.5
V-Ribbed Belt	1.7
Flat Belt	2.5

FEATURES/BENEFITS PAGE G3-3	NOMENCLATURE PAGE G3-6	EASY SELECTION PAGE G3-7	SELECTION/DIMENSIONS PAGE G3-23
--------------------------------	---------------------------	-----------------------------	------------------------------------



ENGINEERING/TECHNICAL

MAXUM Concentric Reducer

Table 14: 1750, 1450 RPM Input - Input Horsepower Ratings

High Speed Shaft RPM	AGMA Nominal Ratio	Approx. Low Speed Shaft RPM	Unit Red.	Rating Data @ 1.0 Service Factor for MAXUM unit size of:														
				1	2	3	4	5	6	7	9	10	11	12				
1750	2.25	777.8	DOUBLE	32.8	52.8	84.8	127	183	248									
	2.75	636.4		30.1	47.2	81.9	122	165	224									
	3.37	519.3		25.7	42.4	70.9	109	147	199									
	4.13	423.7		31.9	52.8	73.4	123	184	221									
	5.06	345.8		28.2	47.2	65.3	111	165	197	402	506	789	1111	1602				
	6.20	282.3		25.1	42.4	57.9	97.3	146	174	345	468	699	1000	1428				
	7.59	230.6		22.0	39.2	50.0	86.0	127	153	323	417	613	884	1284				
	9.30	188.2		18.8	32.5	44.1	75.8	111	135	270	367	538	790	1105				
	11.39	153.6		15.8	27.6	40.0	66.2	95.4	119	230	325	477	690	964				
	13.95	125.4	13.2	22.9	34.1	58.4	78.3	102	190	283	418	604	814					
	17.09	102.4	11.1	19.2	30.1	51.0	63.9	91.4	156	247	370	531	696					
	20.93	83.6	9.15	16.0	25.6	43.1	53.0	79.7	132	216	319	458	596					
	25.63	68.3	7.58	13.5	21.7	34.7	43.5	71.0	108	189	277	375	493					
	1450	31.39	55.8	TRIPLE	6.53	11.6	18.1	30.1	35.2	57.4	87.5	163	233	301	403			
		38.44	45.5		5.44	9.53	15.0	25.1	30.9	50.0	76.8	138	204	272	346			
		47.08	37.2		4.52	7.90	12.6	21.0	26.8	43.6	65.0	114	173	228	291			
		57.67	30.4		3.72	6.50	10.5	17.6	22.3	36.2	54.9	94.2	141	189	242			
		70.62	24.8		3.07	5.41	8.77	14.1	18.3	30.8	45.8	78.2	116	158	198			
86.50		20.2	2.56		4.47	7.28	11.8	14.6	25.1	37.7	63.9	100	131	164				
105.90		16.5	2.12		3.64	5.95	9.90	11.9	20.0	31.8	52.7	81.7	108	134				
129.70		13.5	1.76		3.00	4.96	8.21	9.7	16.9	26.5	43.7	67.2	90.3	112				
158.90		11.0	1.44		2.45	4.09	6.84	8.05	13.8	21.5	36.3	56.1	75.1	93.1				
194.60		9.0	1.19	2.03	3.45	5.38	6.60	11.6	17.9	30.1	46.1	62.5	75.7					
1450		2.25	644.4	DOUBLE	28.3	46.3	73.4	106	154	218								
		2.75	527.3		26.0	41.4	70.8	103	138	196								
		3.37	430.3		22.2	37.2	61.3	92.2	124	175								
		4.13	351.1		28.0	46.3	64.4	106	161	194								
		5.06	286.6		24.7	41.4	57.2	96.9	144	173	349	427	692	974	1404			
		6.20	233.9		22.0	37.2	50.7	85.3	128	153	300	399	613	877	1252			
		7.59	191.0		18.9	33.4	43.9	75.4	112	134	275	365	538	775	1126			
		9.30	155.9		15.9	27.7	38.6	66.4	96.7	119	231	322	471	693	961			
	11.39	127.3	13.4		23.5	34.5	58.1	80.9	104	195	285	418	605	830				
	13.95	103.9	11.2	19.5	29.9	51.2	66.3	89.6	162	248	366	529	700					
	17.09	84.8	9.34	16.3	26.0	43.2	54.2	80.1	132	216	325	466	601					
	20.93	69.3	7.72	13.5	21.6	36.4	44.9	69.9	112	189	280	389	506					
	25.63	56.6	6.39	11.3	18.3	29.3	36.9	62.2	92.0	163	242	324	416					
	1450	31.39	46.2	TRIPLE	5.50	9.76	15.4	25.2	30.9	50.3	76.7	142	205	263	354			
		38.44	37.7		4.58	8.02	12.6	21.2	27.1	42.8	67.3	116	172	230	291			
		47.08	30.8		3.80	6.62	10.6	17.6	22.5	36.7	54.8	95.5	146	193	245			
		57.67	25.1		3.13	5.44	8.72	14.8	18.7	30.5	46.2	79.0	119	159	203			
		70.62	20.5		2.58	4.52	7.38	11.8	15.3	25.9	38.5	65.5	98.0	133	166			
86.50		16.8	2.15		3.73	6.12	9.94	12.3	21.0	31.8	53.5	84.3	110	137				
105.90		13.7	1.78		3.04	5.00	8.31	9.97	16.8	26.7	44.1	68.7	90.9	112				
129.70		11.2	1.48		2.50	4.17	6.89	8.14	14.2	22.2	36.5	56.5	76.0	94.0				
158.90		9.1	1.21		2.04	3.43	5.75	6.75	11.6	18.0	30.4	47.2	63.0	77.9				
194.60		7.5	1.00		1.69	2.89	4.51	5.54	9.70	15.0	25.1	38.7	52.5	63.3				

Mechanical HP ratings shown in shaded areas exceed the unit thermal HP ratings.

Refer to Thermal HP Table 20, page G3-68.

Sizes 1-3 discounted remaining stock may be available.

FEATURES/BENEFITS PAGE G3-3	NOMENCLATURE PAGE G3-6	EASY SELECTION PAGE G3-7	SELECTION/DIMENSIONS PAGE G3-23
--------------------------------	---------------------------	-----------------------------	------------------------------------



MAXUM Concentric Reducer

Table 15: 1750, 1450 RPM Input - Output Torque Ratings (In. - Lb.)

High Speed Shaft RPM	AGMA Nominal Ratio	Approx. Low Speed Shaft RPM	Unit Red.	Rating Data @ 1.0 Service Factor for MAXUM unit size of (multiply value shown by 1000):														
				1	2	3	4	5	6	7	9	10	11	12				
1750	2.25	777.8	DOUBLE	2.55	4.12	6.63	9.81	14.3	19.5									
	2.75	636.4		2.92	4.57	7.82	11.3	15.7	21.5									
	3.37	519.3		3.03	4.95	8.25	12.5	17.0	23.4									
	4.13	423.7		4.52	7.50	10.6	17.5	26.2	31.6									
	5.06	345.8		4.95	8.31	11.5	19.0	28.5	34.3	70.4	89.3	135	196	282				
	6.20	282.3		5.36	9.00	12.4	20.7	30.7	37.2	73.1	99.5	148	212	307				
	7.59	230.6		5.81	10.2	13.5	22.6	33.1	40.5	84.1	108	161	231	332				
	9.30	188.2		6.03	10.5	14.5	24.3	35.4	43.4	86.0	117	175	248	356				
	11.39	153.6		6.17	10.8	15.7	26.2	37.5	46.6	89.1	126	187	269	377				
	13.95	125.4		6.31	11.1	16.6	28.1	37.9	50.4	91.6	136	201	290	394				
	17.09	102.4	6.45	11.4	17.8	30.0	37.9	53.3	94.3	146	214	310	407					
	20.93	83.6	6.59	11.7	18.7	30.6	37.9	57.0	96.3	157	231	330	425					
	25.63	68.3	6.72	11.9	19.0	31.4	37.9	60.5	95.6	167	248	328	436					
	31.39	55.8	6.84	12.2	19.1	32.1	37.4	62.3	90.4	169	250	319	427					
	38.44	45.5	6.96	12.4	19.8	32.5	40.5	68.0	98.5	178	268	355	453					
	47.08	37.2	7.08	12.6	20.1	33.3	43.0	70.1	105	181	273	362	460					
	57.67	30.4	7.20	12.8	20.7	33.7	43.0	71.4	107	184	279	370	467					
	70.62	24.8	7.32	12.9	20.8	34.3	43.0	72.4	108	186	285	377	474					
	86.50	20.2	7.43	13.0	21.1	34.8	43.0	73.2	110	188	289	384	480					
	105.90	16.5	7.53	13.1	21.4	35.3	43.0	73.2	112	190	294	391	486					
129.70	13.5	7.64	13.3	21.8	35.9	43.0	73.2	114	192	300	397	491						
158.90	11.0	7.75	13.3	22.1	36.2	43.0	73.2	116	194	304	405	496						
194.60	9.0	7.85	13.4	22.3	36.2	43.0	73.2	117	196	309	410	502						
1450	2.25	644.4	DOUBLE	2.66	4.36	6.93	9.81	14.5	20.7									
	2.75	527.3		3.04	4.84	8.16	11.5	15.9	22.7									
	3.37	430.3		3.16	5.24	8.61	12.8	17.2	24.7									
	4.13	351.1		4.78	7.93	11.2	18.2	27.7	33.5									
	5.06	286.6		5.24	8.79	12.1	20.1	30.1	36.3	73.8	90.9	143	208	298				
	6.20	233.9		5.67	9.52	13.1	21.9	32.5	39.3	76.5	103	156	225	325				
	7.59	191.0		6.02	10.4	14.3	23.9	35.1	42.9	86.5	114	170	244	351				
	9.30	155.9		6.16	10.8	15.4	25.7	37.4	45.9	89.0	124	185	262	374				
	11.39	127.3		6.30	11.1	16.3	27.8	38.4	49.3	91.3	133	198	285	392				
	13.95	103.9		6.44	11.4	17.6	29.7	38.8	53.3	93.8	144	213	307	409				
	17.09	84.8	6.58	11.7	18.6	30.6	38.8	56.4	96.4	155	227	328	424					
	20.93	69.3	6.71	11.9	19.0	31.2	38.8	60.3	98.4	166	245	338	435					
	25.63	56.6	6.84	12.2	19.4	32.0	38.8	64.1	98.6	174	262	342	444					
	31.39	46.2	6.96	12.4	19.7	32.5	39.6	65.9	95.7	178	265	337	451					
	38.44	37.7	7.07	12.6	20.1	33.1	42.8	70.2	104	181	273	362	460					
	47.08	30.8	7.19	12.8	20.4	33.7	43.6	71.3	107	183	278	369	467					
	57.67	25.1	7.31	12.9	20.8	34.2	43.6	72.5	108	186	284	376	473					
	70.62	20.5	7.42	13.0	21.1	34.8	43.6	73.6	110	188	289	383	480					
	86.50	16.8	7.53	13.1	21.4	35.3	43.6	74.2	112	190	294	390	486					
	105.90	13.7	7.63	13.2	21.7	35.8	43.6	74.2	114	192	299	397	491					
129.70	11.2	7.74	13.3	22.0	36.3	43.6	74.2	115	194	304	403	496						
158.90	9.1	7.84	13.4	22.3	36.7	43.6	74.2	117	196	308	410	501						
194.60	7.5	7.95	13.5	22.6	36.7	43.6	74.2	119	197	313	416	506						

Torque ratings shown in shaded areas exceed the unit thermal HP ratings.
 Convert torque (**without service factor**) to HP per the formula given on page G3-58.
 Refer to Thermal HP Table 20, page G3-68.

Sizes 1-3 discounted remaining stock may be available.

FEATURES/BENEFITS PAGE G3-3	NOMENCLATURE PAGE G3-6	EASY SELECTION PAGE G3-7	SELECTION/DIMENSIONS PAGE G3-23
--------------------------------	---------------------------	-----------------------------	------------------------------------

ENGINEERING/TECHNICAL



MAXUM Concentric Reducer

Table 16: 1170, 870, 720 RPM Input - Input Horsepower Ratings

High Speed Shaft RPM	AGMA Nominal Ratio	Approx. Low Speed Shaft RPM	Unit Red.	Rating Data @ 1.0 Service Factor for MAXUM unit size of:												
				1	2	3	4	5	6	7	9	10	11	12		
1170	2.25	520.0	DOUBLE	23.9	39.8	62.2	85.2	126	182							
	2.75	425.5		22.0	35.6	60.0	84.7	113	163							
	3.37	347.2		18.8	32.0	51.9	75.5	101	144							
	4.13	283.3		23.9	39.8	55.4	85.2	139	167							
	5.06	231.2		21.3	35.6	49.2	83.4	124	149	297	351	595	838	1209		
	6.20	188.7		18.8	32.0	43.6	73.4	110	131	255	329	527	755	1077		
	7.59	154.2		15.6	27.8	37.7	64.8	96.1	115	229	304	463	667	969		
	9.30	125.8		13.2	23.0	33.2	57.1	80.1	102	192	276	406	596	816		
	11.39	102.7		11.1	19.5	29.7	50.0	66.9	89.4	162	245	360	520	699		
	13.95	83.9		9.23	16.1	25.6	42.7	54.3	77.1	134	213	315	455	589		
	17.09	68.5		7.69	13.4	21.5	35.6	44.4	68.9	109	186	279	387	499		
	20.93	55.9		6.35	11.1	17.8	30.0	36.8	60.1	92.4	161	241	322	417		
	25.63	45.6		5.26	9.33	15.1	24.1	30.2	52.5	76.8	135	200	270	342		
	870	31.39		37.3	TRIPLE	4.52	8.02	12.7	20.8	26.6	43.2	66.0	116	171	227	291
38.44		30.4	3.76	6.56		10.4	17.4	22.4	35.2	55.5	95.2	142	189	239		
47.08		24.9	3.12	5.40		8.68	14.5	18.3	30.2	45.1	78.1	120	159	200		
57.67		20.3	2.57	4.43		7.15	12.1	15.2	25.0	38.0	64.5	97.8	131	166		
70.62		16.6	2.12	3.68		6.05	9.7	12.5	21.2	31.6	53.5	80.5	110	136		
86.50		13.5	1.76	3.04		5.01	8.15	9.97	17.1	26.0	43.6	69.3	90.5	112		
105.90		11.0	1.46	2.47		4.09	6.81	8.10	13.6	21.9	35.9	56.4	74.6	91.8		
129.70		9.0	1.21	2.03		3.41	5.64	6.61	11.5	18.2	29.7	46.3	62.3	76.7		
158.90		7.4	0.990	1.66		2.81	4.67	5.49	9.4	14.8	24.7	38.7	51.6	63.5		
194.60		6.0	0.815	1.38		2.37	3.67	4.5	7.88	12.3	20.4	31.7	43.1	51.6		
720		2.25	386.7	DOUBLE		18.9	32.4	49.3	63.4	95.6	139					
		2.75	316.4			17.4	28.9	47.5	63.4	86.2	124					
		3.37	258.2			14.8	26.0	41.1	57.3	77.0	109					
		4.13	210.7			18.9	32.4	45.0	63.4	113	136					
	5.06	171.9	17.2		28.9	40.0	63.4	101	121	236	269	484	681	982		
	6.20	140.3	14.5		25.6	35.5	59.4	89.6	107	203	252	429	613	875		
	7.59	114.6	12.0		21.5	30.7	52.7	74.2	93.5	177	232	376	542	769		
	9.30	93.5	10.1		17.7	27.0	46.4	61.6	82.9	148	211	330	484	643		
	11.39	76.4	8.47		15.0	23.9	38.9	50.5	72.7	124	190	293	423	548		
	13.95	62.4	7.06		12.4	19.6	32.7	41.0	62.7	103	173	256	354	453		
	17.09	50.9	5.88		10.3	16.4	27.2	33.5	56.0	83.7	148	227	298	381		
	20.93	41.6	4.85		8.49	13.6	22.9	27.8	47.2	70.7	123	186	247	318		
	25.63	33.9	4.01		7.11	11.5	18.4	22.8	39.6	59.1	102	153	207	260		
	720	31.39	27.7		TRIPLE	3.44	6.07	9.66	15.8	20.7	33.0	51.6	88.2	131	175	221
38.44		22.6	2.86	4.95		7.91	13.2	16.8	26.8	42.3	72.1	108	145	181		
47.08		18.5	2.37	4.07		6.60	11.0	13.7	23.0	34.3	59.1	91.5	121	152		
57.67		15.1	1.95	3.34		5.44	9.21	11.4	19.0	28.9	48.7	74.6	100	126		
70.62		12.3	1.61	2.77		4.59	7.36	9.32	15.9	24.1	40.4	61.3	83.6	103		
86.50		10.1	1.33	2.28		3.80	6.18	7.46	12.8	19.8	32.9	52.7	68.9	84.7		
105.90		8.2	1.10	1.86		3.10	5.16	6.06	10.2	16.6	27.1	42.9	56.8	69.2		
129.70		6.7	0.914	1.52		2.59	4.23	4.95	8.62	13.8	22.4	35.2	47.4	57.8		
158.90		5.5	0.750	1.25		2.13	3.49	4.11	7.03	11.2	18.6	29.4	39.2	47.8		
194.60		4.5	0.617	1.03		1.79	2.74	3.37	5.89	9.3	15.4	24.1	32.7	38.8		

Mechanical HP ratings shown in shaded areas exceed the unit thermal HP ratings.

Refer to Thermal HP Table 20, page G3-68.

Sizes 1-3 discounted remaining stock may be available.

FEATURES/BENEFITS PAGE G3-3	NOMENCLATURE PAGE G3-6	EASY SELECTION PAGE G3-7	SELECTION/DIMENSIONS PAGE G3-23
--------------------------------	---------------------------	-----------------------------	------------------------------------



MAXUM Concentric Reducer

Table 16: 1170, 870, 720 RPM Input - Input Horsepower Ratings (cont'd)

High Speed Shaft RPM	AGMA Nominal Ratio	Approx. Low Speed Shaft RPM	Unit Red.	Rating Data @ 1.0 Service Factor for MAXUM unit size of:														
				1	2	3	4	5	6	7	9	10	11	12				
720	2.25	320.0	DOUBLE	16.3	28.3	42.5	52.4	80.2	116									
	2.75	261.8		14.9	25.3	40.9	52.4	72.3	104									
	3.37	213.6		12.7	22.8	35.3	48.1	64.6	91.6									
	4.13	174.3		16.3	28.3	39.4	52.4	95.4	119									
	5.06	142.3		14.6	25.3	35.1	52.4	85.9	106	204	226	424	597	861				
	6.20	116.1		12.3	21.7	31.1	50.0	75.9	93.6	175	212	375	537	765				
	7.59	94.9		10.1	18.2	26.9	46.2	62.7	81.9	150	196	329	475	661				
	9.30	77.4		8.51	15.0	23.5	39.6	52.0	72.6	125	178	289	424	550				
	11.39	63.2		7.14	12.7	20.1	32.8	42.7	63.7	105	161	256	360	462				
	13.95	51.6		5.94	10.4	16.5	27.5	34.6	54.9	86.7	151	224	300	381				
	17.09	42.1	4.94	8.64	13.8	22.9	28.3	48.8	70.6	125	191	251	321					
	20.93	34.4	4.07	7.14	11.4	19.3	23.5	39.9	59.6	103	157	208	267					
	25.63	28.1	3.37	5.94	9.66	15.4	19.2	33.4	49.7	85.8	129	175	218					
	31.39	22.9	2.89	5.07	8.12	13.3	17.2	27.7	43.4	73.8	110	147	185					
	38.44	18.7	2.40	4.13	6.64	11.1	14.0	22.5	35.6	60.3	91.0	122	152					
	47.08	15.3	1.99	3.40	5.54	9.23	11.4	19.3	28.9	49.4	77.0	102	127					
	57.67	12.5	1.63	2.78	4.56	7.73	9.46	15.8	24.3	40.7	62.7	84.0	105					
	70.62	10.2	1.35	2.31	3.85	6.17	7.76	13.2	20.2	33.7	51.5	70.2	85.7					
	86.50	8.3	1.12	1.90	3.19	5.18	6.22	10.7	16.6	27.4	44.2	57.8	70.8					
	105.90	6.8	.925	1.55	2.60	4.31	5.05	8.5	13.9	22.6	35.9	47.6	57.8					
129.70	5.6	.765	1.27	2.16	3.52	4.12	7.18	11.6	18.7	29.5	39.7	48.2						
158.90	4.5	.628	1.04	1.78	2.91	3.42	5.86	9.38	15.5	24.6	32.9	39.9						
194.60	3.7	.516	.859	1.50	2.29	2.80	4.91	7.76	12.8	20.2	27.4	32.3						

Mechanical HP ratings shown in shaded areas exceed the unit thermal HP ratings. Refer to Thermal HP Table 20, page G3-68.

Sizes 1-3 discounted remaining sotck may be availble.



MAXUM Concentric Reducer

Table 17: 1170, 870, 720 RPM Input - Output Torque Ratings (In. - Lb.)

High Speed Shaft RPM	AGMA Nominal Ratio	Approx. Low Speed Shaft RPM	Unit Red.	Rating Data @ 1.0 Service Factor for MAXUM unit size of (multiply value shown by 1000):															
				1	2	3	4	5	6	7	9	10	11	12					
1170	2.25	520.0	DOUBLE	2.79	4.65	7.28	9.81	14.7	21.4										
	2.75	425.5		3.18	5.16	8.56	11.7	16.1	23.3										
	3.37	347.2		3.30	5.58	9.03	13.0	17.5	25.2										
	4.13	283.3		5.07	8.46	11.9	18.2	29.5	35.7										
	5.06	231.2		5.59	9.38	12.9	21.4	32.1	38.7	77.7	92.8	153	221	318					
	6.20	188.7		6.00	10.2	14.0	23.4	34.7	41.9	80.5	105	167	239	347					
	7.59	154.2		6.18	10.8	15.3	25.5	37.4	45.7	89.1	118	182	261	374					
	9.30	125.8		6.32	11.1	16.4	27.4	38.4	49.0	91.5	131	197	280	394					
	11.39	102.7		6.45	11.4	17.4	29.6	39.3	52.6	93.8	142	211	304	409					
	13.95	83.9	6.58	11.7	18.7	30.7	39.3	56.8	96.2	153	227	327	426						
	17.09	68.5	6.71	11.9	19.0	31.3	39.3	60.1	98.7	165	242	338	436						
	20.93	55.9	6.85	12.2	19.4	31.9	39.3	64.3	101	175	261	347	444						
	25.63	45.6	6.97	12.4	19.7	32.6	39.3	66.9	102	178	268	354	453						
	870	31.39	37.3	TRIPLE	7.08	12.6	20.1	33.2	42.3	70.2	102	181	273	360	460				
		38.44	30.4		7.20	12.8	20.5	33.7	43.9	71.6	106	184	279	370	468				
		47.08	24.9		7.31	12.9	20.8	34.3	43.9	72.6	109	186	284	377	474				
		57.67	20.3		7.42	13.0	21.1	34.8	43.9	73.8	110	188	289	384	480				
		70.62	16.6		7.54	13.1	21.4	35.4	43.9	74.7	112	190	295	390	486				
86.5		13.5	7.64		13.2	21.7	35.9	43.9	74.7	114	192	299	397	491					
105.9		11.0	7.75		13.3	22.1	36.4	43.9	74.7	116	194	304	404	497					
129.7		9.0	7.85		13.4	22.4	36.9	43.9	74.7	117	196	309	410	501					
158.9		7.4	7.95		13.5	22.7	36.9	43.9	74.7	119	197	313	416	506					
194.6		6.0	8.05		13.6	22.9	36.9	43.9	74.7	121	199	318	422	511					
720		2.25	386.7		DOUBLE	2.97	5.09	7.77	9.81	15.00	21.9								
		2.75	316.4			3.39	5.64	9.13	11.8	16.5	23.9								
	3.37	258.2	3.51	6.10		9.61	13.2	17.9	25.8										
	4.13	210.7	5.39	9.25		13.0	18.2	32.3	39.0										
	5.06	171.9	6.10	10.2		14.2	21.9	35.1	42.3	83.3	95.4	167	242	348					
	6.20	140.3	6.24	10.9		15.3	25.4	37.8	45.8	86.2	108	182	262	379					
	7.59	114.6	6.39	11.2		16.7	27.8	38.8	50.0	92.6	121	199	285	400					
	9.30	93.5	6.52	11.5		17.9	30.0	39.8	53.5	94.9	135	215	306	417					
	11.39	76.4	6.65	11.8		18.8	31.0	39.9	57.5	97.1	148	231	332	431					
	13.95	62.4	6.77	12.1	19.2	31.6	39.9	62.1	99.4	168	248	342	440						
	17.09	50.9	6.90	12.3	19.6	32.2	39.9	65.7	102	176	264	350	448						
	20.93	41.6	7.02	12.5	19.9	32.8	39.9	67.9	104	180	270	358	456						
	25.63	33.9	7.15	12.7	20.3	33.5	39.9	67.9	106	182	276	365	464						
	720	31.39	27.7	TRIPLE	7.25	12.8	20.6	34.0	44.2	72.0	107	184	281	373	470				
		38.44	22.6		7.36	12.9	21.0	34.5	44.2	73.3	109	187	287	380	477				
		47.08	18.5		7.47	13.1	21.3	35.0	44.2	74.3	111	189	291	387	483				
		57.67	15.1		7.58	13.2	21.6	35.5	44.2	75.2	113	191	297	394	488				
		70.62	12.3		7.69	13.3	21.9	36.2	44.2	75.2	115	193	302	400	494				
86.5		10.1	7.79		13.4	22.2	36.6	44.2	75.2	116	195	306	407	499					
105.9		8.2	7.89		13.5	22.5	37.1	44.2	75.2	118	197	311	413	504					
129.7		6.7	7.99		13.6	22.8	37.1	44.2	75.2	120	198	316	419	508					
158.9		5.5	8.09		13.7	23.1	37.1	44.2	75.2	121	200	320	425	512					
194.6	4.5	8.20	13.7	23.3	37.1	44.2	75.2	123	201	324	431	517							

Torque ratings shown in shaded areas exceed the unit thermal HP ratings.

Refer to Thermal HP Table 20, page G3-68

Convert torque (**without service factor**) to HP per the formula on page G3-58.

Sizes 1-3 discounted remaining stock may be available.

FEATURES/BENEFITS PAGE G3-3	NOMENCLATURE PAGE G3-6	EASY SELECTION PAGE G3-7	SELECTION/DIMENSIONS PAGE G3-23
--------------------------------	---------------------------	-----------------------------	------------------------------------



MAXUM Concentric Reducer

Table 17: 1170, 870, 720 RPM Input - Output Torque Ratings (In. - Lb.)

High Speed Shaft RPM	AGMA Nominal Ratio	Approx. Low Speed Shaft RPM	Unit Red.	Rating Data @ 1.0 Service Factor for MAXUM unit size of (multiply value shown by 1000):															
				1	2	3	4	5	6	7	9	10	11	12					
720	2.25	320.0	DOUBLE	3.09	5.38	8.08	9.81	15.3	22.2										
	2.75	261.8		3.52	5.97	9.49	11.80	16.7	24.2										
	3.37	213.6		3.64	6.46	10.0	13.4	18.1	26.1										
	4.13	174.3		5.60	9.79	13.8	18.2	33.0	41.3										
	5.06	142.3		6.24	10.8	15.0	21.9	36.1	44.8	86.9	97.1	177	256	368					
	6.20	116.1		6.37	11.2	16.2	25.9	38.7	48.5	89.9	110	193	277	400					
	7.59	94.9		6.52	11.5	17.6	29.4	39.7	52.9	94.8	123	210	302	415					
	9.30	77.4		6.64	11.8	18.8	30.9	40.6	56.6	97.0	138	228	324	431					
	11.39	63.2		6.77	12.0	19.2	31.6	40.8	60.9	99.1	151	244	342	439					
	13.95	51.6		6.89	12.3	19.6	32.2	40.8	65.7	101	176	263	350	448					
	17.09	42.1	7.01	12.5	19.9	32.8	40.8	69.2	104	180	269	357	456						
	20.93	34.4	7.13	12.7	20.3	33.3	40.8	69.4	106	182	275	365	463						
	25.63	28.1	7.25	12.8	20.6	34.0	40.8	69.4	107	185	281	372	470						
	31.39	22.9	7.36	12.9	20.9	34.5	44.5	73.1	109	187	286	379	476						
	38.44	18.7	7.47	13.0	21.3	35.0	44.5	74.4	111	189	291	387	483						
	47.08	15.3	7.57	13.2	21.6	35.5	44.5	75.4	113	191	296	393	488						
	57.67	12.5	7.68	13.3	21.9	36.0	44.5	75.7	115	193	301	400	493						
	70.62	10.2	7.79	13.4	22.2	36.6	44.5	75.7	116	195	306	406	499						
	86.5	8.3	7.89	13.5	22.5	37.1	44.5	75.7	118	196	310	413	503						
	105.9	6.8	7.98	13.6	22.8	37.4	44.5	75.7	120	198	315	419	508						
129.7	5.6	8.08	13.6	23.1	37.4	44.5	75.7	121	200	320	425	512							
158.9	4.5	8.19	13.7	23.3	37.4	44.5	75.7	123	201	324	431	516							
194.6	3.7	8.29	13.8	23.6	37.4	44.5	75.7	124	202	328	436	521							

Torque ratings shown in shaded areas exceed the unit thermal HP ratings.

Refer to Thermal HP Table 20, page G3-68

Convert torque (**without service factor**) to HP per the formula on page G3-58.

Sizes 1-3 discounted remaining stock may be available.

FEATURES/BENEFITS PAGE G3-3	NOMENCLATURE PAGE G3-6	EASY SELECTION PAGE G3-7	SELECTION/DIMENSIONS PAGE G3-23
--------------------------------	---------------------------	-----------------------------	------------------------------------

ENGINEERING/TECHNICAL



MAXUM Concentric Reducer

Table 18: 580, 100 RPM Input - Input Horsepower Ratings

High Speed Shaft RPM	AGMA Nominal Ratio	Approx. Low Speed Shaft RPM	Unit Red.	Rating Data @ 1.0 Service Factor for MAXUM unit size of:														
				1	2	3	4	5	6	7	9	10	11	12				
580	2.25	257.8	DOUBLE	13.7	24.4	35.8	42.2	65.6	95.2									
	2.75	210.9		12.5	21.8	34.4	42.2	59.2	85.0									
	3.37	172.1		10.7	19.6	29.7	39.3	52.9	75.0									
	4.13	140.4		13.7	24.4	33.9	42.2	78.1	102.0									
	5.06	114.6		12.0	21.2	30.1	42.2	70.3	90.9	172	186	358	513	739				
	6.20	93.5		10.1	18.0	26.7	41.1	62.6	80.4	147	174	323	462	643				
	7.59	76.4		8.35	15.1	23.1	38.5	51.7	70.4	124	161	283	408	553				
	9.30	62.4		7.00	12.4	19.4	32.6	42.4	62.4	103	146	248	360	453				
	11.39	50.9		5.86	10.4	16.5	27.0	34.6	54.7	86.6	132	220	297	380				
	13.95	41.6		4.88	8.55	13.6	22.6	28.1	46.7	71.3	124	186	247	313				
	17.09	33.9	4.06	7.08	11.3	18.8	22.9	39.7	58.0	102	158	207	263					
	20.93	27.7	3.34	5.81	9.36	15.8	19.0	32.4	48.9	84.3	129	171	219					
	25.63	22.6	2.76	4.83	7.92	12.6	15.6	27.1	40.8	70.0	106	144	179					
	31.39	18.5	2.36	4.12	6.65	10.9	13.9	22.70	35.60	60.2	90.2	121	151					
	38.44	15.1	1.96	3.36	5.43	9.1	11.3	18.4	29.2	49.1	74.7	100	124					
	47.08	12.3	1.63	2.76	4.53	7.55	9.25	15.7	23.6	40.2	63.1	83.5	104					
	57.67	10.1	1.33	2.26	3.73	6.32	7.67	12.8	19.9	33.1	51.3	68.8	85.8					
	70.62	8.2	1.10	1.87	3.14	5.05	6.29	10.7	16.5	27.4	42.1	57.5	69.7					
	86.5	6.7	.912	1.54	2.60	4.23	5.04	8.64	13.6	22.3	36.2	47.3	57.5					
	105.9	5.5	.755	1.25	2.12	3.49	4.09	6.89	11.4	18.3	29.4	38.9	47					
129.7	4.5	.625	1.03	1.77	2.85	3.34	5.82	9.47	15.2	24.1	32.5	39.2						
158.9	3.7	.512	.840	1.45	2.36	2.77	4.75	7.62	12.6	20.1	26.8	32.4						
194.6	3.0	.421	.697	1.22	1.85	2.27	3.98	6.29	10.4	16.5	22.4	26.3						
100	2.25	44.4	DOUBLE	2.36	4.20	7.28	11.3	16.4										
	2.75	36.4		2.16	3.75	5.93	7.28	10.2	14.7									
	3.37	29.7		1.84	3.38	5.12	6.77	9.1	12.9									
	4.13	24.2		2.36	4.20	5.84	7.28	13.5	17.6									
	5.06	19.8		2.07	3.65	5.20	7.28	12.1	15.7	29.7	32.1	61.8	88.4	127.5				
	6.20	16.1		1.74	3.10	4.60	7.09	10.8	13.9	25.4	30.1	55.6	79.6	110.9				
	7.59	13.2		1.44	2.60	3.98	6.63	8.92	12.1	21.3	27.8	48.8	70.4	95.3				
	9.30	10.8		1.21	2.13	3.34	5.63	7.31	10.8	17.8	25.2	42.8	62.1	78.0				
	11.39	8.8		1.01	1.79	2.85	4.65	5.96	9.43	14.9	22.8	38.0	51.2	65.5				
	13.95	7.2		.84	1.47	2.34	3.90	4.84	8.06	12.3	21.4	32.0	42.6	53.9				
	17.09	5.9	.70	1.22	1.96	3.25	3.96	6.84	10.0	17.6	27.2	35.7	45.3					
	20.93	4.8	.58	1.00	1.61	2.72	3.28	5.58	8.44	14.5	22.2	29.6	37.7					
	25.63	3.9	.48	.833	1.37	2.18	2.69	4.68	7.04	12.1	18.3	24.8	30.8					
	31.39	3.2	.408	.711	1.15	1.88	2.40	3.92	6.13	10.4	15.6	20.8	26.1					
	38.44	2.6	.338	.579	.937	1.57	1.95	3.18	5.03	8.47	12.9	17.2	21.3					
	47.08	2.1	.280	.476	.781	1.30	1.59	2.71	4.07	6.93	10.9	14.4	17.8					
	57.67	1.7	.230	.389	.643	1.09	1.32	2.21	3.43	5.71	8.85	11.9	14.8					
	70.62	1.4	.190	.323	.542	.870	1.08	1.85	2.85	4.72	7.26	9.91	12.0					
	86.50	1.2	.157	.266	.449	.730	.869	1.49	2.34	3.84	6.24	8.16	9.9					
	105.9	.9	.130	.216	.366	.602	.706	1.19	1.97	3.16	5.07	6.71	8.1					
129.7	.8	.108	.177	.305	.492	.576	1.00	1.63	2.61	4.15	5.60	6.75						
158.9	.6	.088	.145	.250	.407	.478	.819	1.31	2.17	3.47	4.63	5.58						
194.6	.5	.073	.120	.211	.319	.392	.686	1.09	1.79	2.84	3.86	4.53						

Torque ratings shown in shaded areas exceed the unit thermal HP ratings.

Refer to Thermal HP Table 20, page G3-68

Convert torque (**without service factor**) to HP per the formula on page G3-58.

Sizes 1-3 discounted remaining stock may be available.

FEATURES/BENEFITS PAGE G3-3	NOMENCLATURE PAGE G3-6	EASY SELECTION PAGE G3-7	SELECTION/DIMENSIONS PAGE G3-23
--------------------------------	---------------------------	-----------------------------	------------------------------------



MAXUM Concentric Reducer

Table 19: 580, 100 RPM Input - Output Torque Ratings (In. - Lb.)

High Speed Shaft RPM	AGMA Nominal Ratio	Approx. Low Speed Shaft RPM	Unit Red.	Rating Data @ 1.0 Service Factor for MAXUM unit size of (multiply value shown by 1000):														
				1	2	3	4	5	6	7	9	10	11	12				
580	2.25	257.8	DOUBLE	3.22	5.74	8.45	9.81	15.5	22.6									
	2.75	210.9		3.67	6.36	9.91	11.8	17.0	24.6									
	3.37	172.1		3.80	6.89	10.40	13.6	18.4	26.5									
	4.13	140.4		5.85	10.4	14.7	18.2	33.5	44.1									
	5.06	114.6		6.39	11.2	16.0	21.9	36.7	47.8	91.1	99.1	185	273	393				
	6.20	93.5		6.52	11.5	17.3	26.4	39.7	51.8	94.1	112	206	296	417				
	7.59	76.4		6.66	11.8	18.8	30.5	40.6	56.4	97.2	126	224	322	431				
	9.30	62.4		6.78	12.1	19.2	31.6	41.0	60.4	99.3	141	243	341	440				
	11.39	50.9		6.90	12.3	19.6	32.2	41.0	64.9	101	154	260	350	448				
	13.95	41.6		7.02	12.5	19.9	32.8	41.0	69.5	104	180	270	358	457				
	17.09	33.9	7.14	12.7	20.3	33.4	41.0	69.8	106	182	275	365	463					
	20.93	27.7	7.26	12.8	20.6	33.9	41.0	69.8	108	185	281	373	470					
	25.63	22.6	7.37	12.9	20.9	34.5	41.0	69.8	109	187	287	380	477					
	31.39	18.5	7.47	13.1	21.3	35.1	44.7	74.4	111	189	292	387	483					
	38.44	15.1	7.58	13.2	21.6	35.6	44.7	75.7	113	191	297	394	489					
	47.08	12.3	7.68	13.3	21.9	36.1	44.7	76.2	115	193	301	400	494					
	57.67	10.1	7.79	13.4	22.2	36.6	44.7	76.2	116	195	306	407	499					
	70.62	8.2	7.90	13.5	22.5	37.2	44.7	76.2	118	196	311	413	504					
	86.50	6.7	8.00	13.6	22.8	37.6	44.7	76.2	120	198	315	419	508					
	105.9	5.5	8.09	13.7	23.1	37.6	44.7	76.2	121	200	320	425	513					
129.7	4.5	8.19	13.7	23.4	37.6	44.7	76.2	123	201	324	431	517						
158.9	3.7	8.29	13.8	23.6	37.6	44.7	76.2	124	203	328	437	521						
194.6	3.0	8.38	13.9	23.9	37.6	44.7	76.2	125	204	333	442	525						
100	2.25	44.4	DOUBLE	3.22	5.74	8.45	9.81	15.5	22.6									
	2.75	36.4		3.67	6.36	9.91	11.8	17.0	24.6									
	3.37	29.7		3.80	6.89	10.40	13.6	18.4	26.5									
	4.13	24.2		5.85	10.4	14.7	18.2	33.5	44.1									
	5.06	19.8		6.39	11.2	16.0	21.9	36.7	47.8	91.1	99.1	185	273	393				
	6.20	16.1		6.52	11.5	17.3	26.4	39.7	51.8	94.1	112	206	296	417				
	7.59	13.2		6.66	11.8	18.8	30.5	40.6	56.4	97.2	126	224	322	431				
	9.30	10.8		6.78	12.1	19.2	31.6	41.0	60.4	99.3	141	243	341	440				
	11.39	8.8		6.90	12.3	19.6	32.2	41.0	64.9	101	154	260	350	448				
	13.95	7.2		7.02	12.5	19.9	32.8	41.0	69.5	104	180	270	358	457				
	17.09	5.9	7.14	12.7	20.3	33.4	41.0	69.8	106	182	275	365	463					
	20.93	4.8	7.26	12.8	20.6	33.9	41.0	69.8	108	185	281	373	470					
	25.63	3.9	7.37	12.9	20.9	34.5	41.0	69.8	109	187	287	380	477					
	31.39	3.2	7.47	13.1	21.3	35.1	44.7	74.4	111	189	292	387	483					
	38.44	2.6	7.58	13.2	21.6	35.6	44.7	75.7	113	191	297	394	489					
	47.08	2.1	7.68	13.3	21.9	36.1	44.7	76.2	115	193	301	400	494					
	57.67	1.7	7.79	13.4	22.2	36.6	44.7	76.2	116	195	306	407	499					
	70.62	1.4	7.90	13.5	22.5	37.2	44.7	76.2	118	196	311	413	504					
	86.50	1.2	8.00	13.6	22.8	37.6	44.7	76.2	120	198	315	419	508					
	105.9	.9	8.09	13.7	23.1	37.6	44.7	76.2	121	200	320	425	513					
129.7	.8	8.19	13.7	23.4	37.6	44.7	76.2	123	201	324	431	517						
158.9	.6	8.29	13.8	23.6	37.6	44.7	76.2	124	203	328	437	521						
194.6	.5	8.38	13.9	23.9	37.6	44.7	76.2	125	204	333	442	525						

Torque ratings shown in shaded areas exceed the unit thermal HP ratings
 Convert torque (without service factor) to HP per the formula given on page G3-58.
 Refer to Thermal HP Table 20, page G3-68.

Sizes 1-3 discounted remaining stock may be available.

FEATURES/BENEFITS PAGE G3-3	NOMENCLATURE PAGE G3-6	EASY SELECTION PAGE G3-7	SELECTION/DIMENSIONS PAGE G3-23
--------------------------------	---------------------------	-----------------------------	------------------------------------



ENGINEERING/TECHNICAL

MAXUM Concentric Reducer

Table 20: Thermal Horsepower Ratings *

High Speed Shaft RPM	AGMA Nominal Ratio	Thermal Horsepower Ratings Without Fan †										Thermal Horsepower Ratings With Fan ‡									
		2	3	4	5	6	7	9	10	11	12	3	4	5	6	7	9	10	11	12	
1750	2.25	42	54	55	55	44						-	-	155	185						
	2.75	45	59	62	66	72						-	-	-	211						
	3.37	-	60	67	74	89						-	-	-	-						
	4.13	33	46	51	57	61						-	116	138	170						
	5.06	34	47	53	61	71	143	72	0	0	0	-	-	137	174	285	373	299	362	256	
	6.20	33	46	54	61	76	150	101	43	0	0	-	-	131	173	284	381	344	433	393	
	7.59	32	44	54	61	81	150	121	90	69	39	-	-	-	-	273	385	376	473	500	
	9.30	29	41	52	58	79	147	132	115	112	118	-	-	-	-	262	-	379	493	543	
	11.39	-	39	48	55	76	140	137	126	140	158	-	-	-	-	-	-	368	489	548	
	13.95	-	-	45	51	70	131	132	129	149	181	-	-	-	-	-	-	349	462	536	
	17.09	-	-	41	46	64	121	126	127	151	189	-	-	-	-	-	-	326	436	513	
	20.93	-	-	37	42	58	111	115	121	148	184	-	-	-	-	-	-	300	405	475	
	25.63	-	-	-	39	54	100	106	110	137	179	-	-	-	-	-	-	268	364	445	
	31.39	-	-	-	-	-	-	125	114	179	169	-	-	-	-	-	-	-	-	-	
	38.44	-	-	-	-	-	-	111	106	161	157	-	-	-	-	-	-	-	-	-	
	47.08	-	-	-	-	-	-	103	98	147	147	-	-	-	-	-	-	-	-	-	
	57.67	-	-	-	-	-	-	-	90	133	135	-	-	-	-	-	-	-	-	-	
70.62	-	-	-	-	-	-	-	81	118	125	-	-	-	-	-	-	-	-	-		
1450	2.25	-	62	68	72	77						-	-	-	204						
	2.75	-	64	72	80	95						-	-	-	-						
	3.37	-	-	72	82	105						-	-	-	-						
	4.13	34	49	56	66	78						-	-	-	136	174					
	5.06	34	49	57	66	82	159	120	60	30	0	-	-	132	-	280	388	352	440	406	
	6.20	32	47	55	64	83	160	136	101	89	55	-	-	126	-	274	389	375	476	484	
	7.59	32	-	55	63	84	155	144	128	131	135	-	-	-	-	261	-	384	493	545	
	9.30	-	-	52	59	81	150	147	140	154	180	-	-	-	-	-	-	374	495	556	
	11.39	-	-	47	55	76	142	146	142	166	199	-	-	-	-	-	-	358	478	547	
	13.95	-	-	44	51	69	131	137	139	165	206	-	-	-	-	-	-	334	445	522	
	17.09	-	-	41	46	64	121	129	132	160	204	-	-	-	-	-	-	309	413	493	
	20.93	-	-	-	42	58	111	116	123	153	194	-	-	-	-	-	-	-	384	454	
	25.63	-	-	-	-	53	-	106	111	139	185	-	-	-	-	-	-	-	-	-	
	31.39	-	-	-	-	-	-	124	119	191	183	-	-	-	-	-	-	-	-	-	
	38.44	-	-	-	-	-	-	113	111	172	170	-	-	-	-	-	-	-	-	-	
	47.08	-	-	-	-	-	-	-	103	156	159	-	-	-	-	-	-	-	-	-	
	57.67	-	-	-	-	-	-	-	95	142	146	-	-	-	-	-	-	-	-	-	
70.62	-	-	-	-	-	-	-	85	126	136	-	-	-	-	-	-	-	-	-		
1170	2.25	-	-	77	84	104						-	-	-	169						
	2.75	-	-	77	88	113						-	-	-	-						
	3.37	-	-	75	87	115						-	-	-	-						
	4.13	35	50	60	69	88						-	-	-	104	136					
	5.06	34	-	58	68	89	168	155	123	122	101	-	-	101	135	219	316	295	373	371	
	6.20	-	-	55	65	87	165	160	144	153	157	-	-	96	130	212	310	306	390	409	
	7.59	-	-	54	63	85	158	160	154	172	203	-	-	91	-	202	299	304	392	442	
	9.30	-	-	51	59	81	150	155	154	182	221	-	-	-	-	191	-	292	389	442	
	11.39	-	-	46	55	75	142	150	151	182	226	-	-	-	-	-	-	278	372	430	
	13.95	-	-	-	51	68	130	138	143	172	220	-	-	-	-	-	-	258	342	406	
	17.09	-	-	-	-	62	-	129	142	165	212	-	-	-	-	-	-	254	320	383	
	20.93	-	-	-	-	56	-	116	123	155	198	-	-	-	-	-	-	217	296	352	
	25.63	-	-	-	-	52	-	106	111	139	187	-	-	-	-	-	-	193	264	328	
	31.39	-	-	-	-	-	-	-	-	122	195	192	-	-	-	-	-	-	-	-	
	38.44	-	-	-	-	-	-	-	-	113	175	178	-	-	-	-	-	-	-	-	
	47.08	-	-	-	-	-	-	-	-	110	167	167	-	-	-	-	-	-	-	-	
	57.67	-	-	-	-	-	-	-	-	96	154	154	-	-	-	-	-	-	-	-	

* Actual horsepower, without service factor, that reducer will transmit continuously without overheating.

† Values shown are horsepower ratings when thermal HP is less than mechanical HP.

- No values listed if thermal HP is equal to or greater than mechanical HP.

‡ For thermal capacities beyond the range of cooling fans, refer to heat exchanger page G3-40 or consult DODGE.

█ Sizes 1-3 discounted remaining stock may be available.

FEATURES/BENEFITS PAGE G3-3	NOMENCLATURE PAGE G3-6	EASY SELECTION PAGE G3-7	SELECTION/DIMENSIONS PAGE G3-23
--------------------------------	---------------------------	-----------------------------	------------------------------------



MAXUM Concentric Reducer

Table 20: Thermal Horsepower Ratings (cont'd)

High Speed Shaft RPM	AGMA Nominal Ratio	Thermal Horsepower Ratings Without Fan †										Thermal Horsepower Ratings With Fan ‡									
		2	3	4	5	6	7	9	10	11	12	3	4	5	6	7	9	10	11	12	
870	2.25	-	-	-	92	121															
	2.75	-	-	-	-	123															
	3.37	-	-	-	-	-															
	4.13	-	-	61	71	94															
	5.06	-	-	57	67	91	169	180	166	189	211										
	6.2	-	-	54	64	87	163	176	170	198	231										
	7.59	-	-	52	61	84	155	169	169	199	248										
	9.3	-	-	-	57	79	146	159	162	197	247										
	11.39	-	-	-	-	-	-	150	154	189	240										
	13.95	-	-	-	-	-	-	134	142	175	227										
	17.09	-	-	-	-	-	-	125	131	165	215										
	20.93	-	-	-	-	-	-	113	121	153	197										
	25.63	-	-	-	-	-	-	-	108	136	189										
31.39	-	-	-	-	-	-	-	-	122	195											
720	2.25	-	-	-	-	-															
	2.75	-	-	-	-	-															
	3.37	-	-	-	-	-															
	4.13	-	-	-	70	93															
	5.06	-	-	-	67	90	167	186	177	209	246										
	6.2	-	-	-	63	90	160	180	176	210	251										
	7.59	-	-	-	60	-	-	170	170	206	259										
	9.3	-	-	-	-	-	-	158	160	199	252										
	11.39	-	-	-	-	-	-	148	150	189	241										
	13.95	-	-	-	-	-	-	131	139	180	226										
	17.09	-	-	-	-	-	-	122	129	163	212										
	20.93	-	-	-	-	-	-	-	118	150	194										
	25.63	-	-	-	-	-	-	-	105	133	180										
580	2.25	-	-	-	-	-															
	2.75	-	-	-	-	-															
	3.37	-	-	-	-	-															
	4.13	-	-	-	-	-															
	5.06	-	-	-	-	-	161			183	217	264									
	6.2	-	-	-	-	-	-			176	214	262									
	7.59	-	-	-	-	-	-			167	204	263									
	9.3	-	-	-	-	-	-			156	196	251									
	11.39	-	-	-	-	-	-			145	185	238									
	13.95	-	-	-	-	-	-			134	170	221									
	17.09	-	-	-	-	-	-			124	158	206									
	20.93	-	-	-	-	-	-			113	145	187									
	25.63	-	-	-	-	-	-			101	128	174									

* Actual horsepower, without service factor, that reducer will transmit continuously without overheating.

† Values shown are horsepower ratings when thermal HP is less than mechanical HP.

- No values listed if thermal HP is equal to or greater than mechanical HP.

‡ For thermal capacities beyond the range of cooling fans, refer to heat exchanger page G3-40 or consult DODGE.

§ Sizes 1-3 discounted remaining stock may be available.



ENGINEERING/TECHNICAL

MAXUM Concentric Reducer

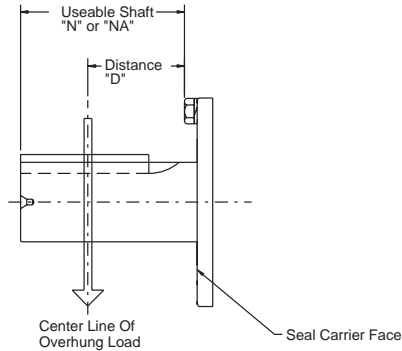

Table 21: Load Location Factors for High Speed Shafts

Distance In Inches	MAXUM Reducer Size									
	1	2	3	4	5		6		7	
	DCR1/ TCR1	DCR2/ TCR2	DCR3/ TCR3	DCR4/ TCR4	DCR5	TCR5	DCR6	TCR6	DCR7	TCR7
1.00	0.99	0.99	0.96	0.96	0.93	0.96	0.93	0.95	0.92	0.92
1.25	1.07	1.07	0.99	0.99	0.95	1.00	0.95	0.98	0.94	0.95
1.50	1.17	1.17	1.06	1.06	0.97	1.08	0.98	1.04	0.95	0.97
1.75	1.27	1.27	1.14	1.14	1.00	1.16	1.00	1.12	0.97	0.99
2.00	1.37	1.37	1.23	1.23	1.07	1.24	1.07	1.20	0.99	1.03
2.25	1.47	1.47	1.31	1.31	1.13	1.31	1.13	1.28	1.01	1.09
2.50	1.57	1.57	1.40	1.40	1.20	1.39	1.20	1.35	1.06	1.14
2.75	1.67	1.67	1.49	1.49	1.27	1.47	1.27	1.43	1.12	1.20
3.00	1.77	1.77	1.57	1.57	1.34	1.55	1.34	1.51	1.18	1.25
3.50			1.74	1.74	1.48	1.71	1.48	1.66	1.29	1.36
4.00					1.62		1.62		1.40	1.47
4.50					1.75		1.75		1.51	
5.00									1.63	
5.50									1.74	
Distance In Inches	9		10		11		12			
	DCR9	TCR9	DCR10	TCR10	DCR11	TCR11	DCR12	TCR12		
1.00	0.91	0.91	0.89	0.87	0.87	0.88	0.87	0.90		
1.25	0.93	0.93	0.90	0.89	0.88	0.90	0.88	0.91		
1.50	0.94	0.95	0.92	0.91	0.89	0.92	0.89	0.93		
1.75	0.95	0.97	0.93	0.93	0.91	0.93	0.90	0.95		
2.00	0.97	0.99	0.94	0.94	0.92	0.95	0.92	0.97		
2.25	0.98	1.03	0.96	0.96	0.93	0.97	0.93	0.99		
2.50	1.00	1.07	0.97	0.98	0.94	0.99	0.94	1.02		
2.75	1.03	1.12	0.98	1.00	0.95	1.01	0.95	1.07		
3.00	1.08	1.17	1.00	1.04	0.96	1.05	0.96	1.11		
3.50	1.17	1.26	1.07	1.12	0.99	1.14	0.99	1.20		
4.00	1.26	1.36	1.16	1.21	1.04	1.22	1.04	1.29		
4.50	1.35	1.45	1.25	1.29	1.11	1.31	1.11	1.38		
5.00	1.45		1.34	1.38	1.18	1.39	1.18	1.47		
5.50	1.54		1.43		1.25		1.25			
6.00	1.63		1.52		1.32		1.32			
6.50	1.72		1.60		1.39		1.39			

Sizes 1-3 discounted remaining stock may be available.



MAXUM Concentric Reducer

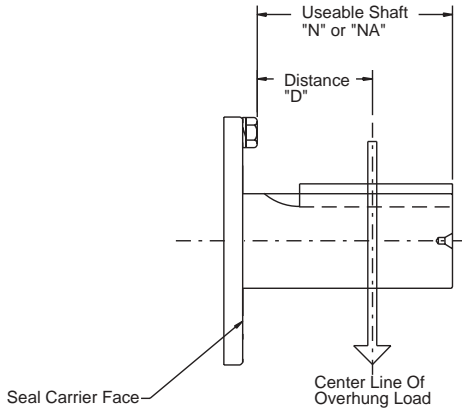

$$OHL = \frac{126,000 \times hp \times Fc \times Lf}{PD \times rpm}$$

- Where:
- OHL = Overhung Load
 - hp = Horsepower
 - Fc = Load Connection Factor
(See Table 13, page G3-59)
 - Lf = Load Location Factor
(See Table 21 for High Speed Shafts
See Table 22 for Low Speed Shafts)
 - PD = Pitch Diameter of the Item mounted on the Shaft
 - rpm = Speed of Shaft with Overhung Load on it in
Revolutions Per Minute
(Interpolate for shaft speeds not listed)

Table 22: Load Location Factors For Low Speed Shafts

Distance In Inches	MAXUM Reducer Size											
	1	2	3	4	5	6	7	9	10	11	12	
1.00	0.93	0.89	0.80	0.83	0.85	0.79	0.79	0.76	0.73	0.72	0.70	
1.25	0.98	0.92	0.84	0.86	0.88	0.82	0.81	0.78	0.74	0.74	0.72	
1.50	1.04	0.96	0.87	0.88	0.90	0.84	0.83	0.79	0.76	0.75	0.73	
1.75	1.12	1.00	0.90	0.91	0.93	0.86	0.85	0.81	0.77	0.77	0.74	
2.00	1.20	1.07	0.93	0.94	0.95	0.88	0.87	0.83	0.79	0.78	0.76	
2.25	1.28	1.13	0.97	0.97	0.98	0.90	0.89	0.84	0.80	0.80	0.77	
2.50	1.36	1.20	1.00	1.00	1.01	0.93	0.91	0.86	0.82	0.81	0.79	
2.75	1.44	1.27	1.05	1.05	1.05	0.95	0.93	0.87	0.83	0.82	0.80	
3.00	1.52	1.34	1.11	1.10	1.10	0.97	0.95	0.89	0.85	0.84	0.81	
3.50	1.69	1.48	1.22	1.21	1.19	1.03	0.99	0.92	0.88	0.87	0.84	
4.00		1.62	1.33	1.32	1.28	1.11	1.06	0.95	0.91	0.90	0.87	
4.50		1.75	1.44	1.42	1.37	1.20	1.14	0.99	0.94	0.92	0.90	
5.00			1.55	1.53	1.46	1.28	1.22	1.03	0.97	0.95	0.93	
5.50			1.66	1.64	1.55	1.37	1.30	1.09	1.00	0.98	0.95	
6.00				1.74	1.64	1.45	1.38	1.14	1.06	1.02	0.98	
6.50					1.74	1.54	1.45	1.20	1.11	1.07	1.02	
7.00					1.83	1.62	1.53	1.25	1.17	1.12	1.07	
7.50						1.71	1.61	1.31	1.23	1.17	1.12	
8.00							1.69	1.36	1.28	1.22	1.16	
8.50								1.42	1.34	1.27	1.21	
9.00								1.48	1.39	1.32	1.26	
9.50								1.53	1.45	1.37	1.31	
10.00								1.59	1.50	1.42	1.36	
10.50								1.64	1.56	1.47	1.41	
11.00								1.70	1.61	1.52	1.46	
11.50										1.57	1.51	
12.00											1.56	

Sizes 1-3 discounted remaining stock may be available.

FEATURES/BENEFITS PAGE G3-3	NOMENCLATURE PAGE G3-6	EASY SELECTION PAGE G3-7	SELECTION/DIMENSIONS PAGE G3-23
--------------------------------	---------------------------	-----------------------------	------------------------------------

ENGINEERING/TECHNICAL



MAXUM Concentric Reducer Table 23: High Speed Shaft Overhung Loads

High Speed Shaft RPM	AGMA Nominal Ratio	Approx. Low Speed Shaft RPM	Unit Red.	High Speed Shaft Overhung Load (pounds) for MAXUM Reducer Size.											
				1	2	3	4	5	6	7	9	10	11	12	
1450	5.06	286.6	DOUBLE	470	0	570	270	1080	960	1400	30	1750	2000	600	
	6.2	233.9		470	0	590	420	1080	1000	1400	30	1750	2000	640	
	7.59	191		470	140	600	660	1080	1250	1400	100	1750	2000	1930	
	9.3	155.9		470	200	600	700	1080	1250	1400	400	1750	2000	2000	
	11.39	127.3		470	250	600	810	1080	1250	1400	550	1750	2000	2000	
	13.95	103.9		470	290	580	770	1080	1250	1400	1750	1750	1900	2000	
	17.09	84.8		470	310	560	800	1080	1190	1400	1750	1750	1590	2000	
	20.93	69.3		470	330	590	850	1080	1040	1400	1750	1750	1750	2000	
	25.63	56.6		470	100	610	0	1000	1250	670	1500	1750	2000	2000	
	31.39	46.2	180	70	20	150	0	80	280	1000	1200	1200	0		
	38.44	37.7	180	180	150	310	190	410	670	1180	1200	1200	1200		
	47.08	30.8	180	260	220	420	370	600	900	1180	1200	1200	1200		
	57.67	25.1	180	270	280	500	490	760	900	1180	1200	1200	1200		
	70.62	20.5	180	270	310	540	580	800	900	1180	1200	1200	1200		
	86.5	16.8	100	140	110	270	160	280	600	800	900	1080	1000		
	105.9	13.7	100	140	180	270	290	470	600	800	900	1080	1180		
	129.7	11.2	100	140	180	270	290	470	600	800	900	1080	1180		
	158.9	9.1	100	140	180	270	290	470	250	270	0	400	1180		
194.6	7.5	100	140	180	270	290	470	420	550	520	900	1180			
1170	5.06	231.2	DOUBLE	470	0	610	90	1080	1020	1400	30	1750	2000	640	
	6.2	188.7		470	0	630	250	1080	1070	1400	30	1750	2000	690	
	7.59	154.2		470	200	640	530	1080	1250	1400	30	1750	2000	2000	
	9.3	125.8		470	270	640	590	1080	1250	1400	30	1750	2000	2000	
	11.39	102.7		470	320	630	870	1080	1250	1400	200	1750	2000	2000	
	13.95	83.9		470	360	620	900	1080	1250	1400	1750	1750	2000	2000	
	17.09	68.5		470	390	660	900	1080	1250	1400	1750	1750	2000	2000	
	20.93	55.9		470	420	690	900	1080	1110	1400	1750	1750	2000	2000	
	25.63	45.6		470	80	710	0	950	1250	650	1500	1750	2000	2000	
	31.39	37.3	180	110	60	210	0	90	300	1180	1200	1200	420		
	38.44	30.4	180	220	180	360	260	510	820	1180	1200	1200	1200		
	47.08	24.9	180	270	250	480	440	690	900	1180	1200	1200	1200		
	57.67	20.3	180	270	310	540	550	800	900	1180	1200	1200	1200		
	70.62	16.6	180	270	340	540	600	800	900	1180	1200	1200	1200		
	86.5	13.5	100	140	180	270	260	420	600	800	900	1080	1000		
	105.9	11	100	140	180	270	290	470	600	800	900	1080	1180		
	129.7	9	100	140	180	270	290	470	600	800	900	1080	1180		
	158.9	7.4	100	140	180	270	290	470	250	270	0	370	1180		
194.6	6	100	140	180	270	290	470	420	520	500	850	1180			
870	5.06	171.9	DOUBLE	470	0	660	80	1080	1110	1400	50	1200	2000	700	
	6.2	140.3		470	30	680	20	1080	1170	1400	50	1750	2000	750	
	7.59	114.6		470	310	700	320	1080	1250	1400	50	1750	2000	2000	
	9.3	93.5		470	380	700	410	1080	1250	1400	50	1750	2000	2000	
	11.39	76.4		470	430	710	900	1080	1250	1400	50	1750	2000	2000	
	13.95	62.4		470	480	770	900	1080	1250	1400	1750	1750	2000	2000	
	17.09	50.9		470	510	800	900	1080	1250	1400	1750	1750	2000	2000	
	20.93	41.6		470	540	800	900	1080	1250	1400	1750	1750	2000	2000	
	25.63	33.9		470	60	800	0	900	1250	650	1400	1750	2000	2000	
	31.39	27.7	180	169	120	300	80	280	490	1180	1200	1200	1070		
	38.44	22.6	180	270	230	450	370	640	900	1180	1200	1200	1200		
	47.08	18.5	180	270	300	540	540	800	900	1180	1200	1200	1200		
	57.67	15.1	180	270	350	540	600	800	900	1180	1200	1200	1200		
	70.62	12.3	180	270	370	540	600	800	900	1180	1200	1200	1200		
	86.5	10.1	100	140	180	270	290	470	600	800	900	1080	900		
	105.9	8.2	100	140	180	270	290	470	600	800	900	1080	1180		
	129.7	6.7	100	140	180	270	290	470	600	800	900	1080	1180		
	158.9	5.5	100	140	180	270	290	470	250	250	0	350	1180		
194.6	4.5	100	140	180	270	290	470	420	500	470	800	1180			

† Capacities listed are for pure radial loads on a reducer. If overhung load exceeds the value shown or if overhung load is applied at the same time as thrust loads, consult DODGE Application Engineering.

■ Sizes 1-3 discounted remaining stock may be available.

FEATURES/BENEFITS PAGE G3-3	NOMENCLATURE PAGE G3-6	EASY SELECTION PAGE G3-7	SELECTION/DIMENSIONS PAGE G3-23
--------------------------------	---------------------------	-----------------------------	------------------------------------



MAXUM Concentric Reducer

Table 23: High Speed Shaft Overhung Loads (cont'd)

High Speed Shaft RPM	AGMA Nominal Ratio	Approx. Low Speed Shaft RPM	Unit Red.	High Speed Shaft Overhung Load (pounds) † for MAXUM Reducer Size											
				1	2	3	4	5	6	7	9	10	11	12	
720	5.06	142.3	DOUBLE	470	0	700	170	1080	1180	1400	50	500	1650	740	
	6.2	116.1		470	100	730	20	1080	1240	1400	50	1500	2000	860	
	7.59	94.9		470	380	740	180	1080	1250	1400	50	1750	2000	2000	
	9.3	77.4		470	460	750	370	1080	1250	1400	50	1750	2000	2000	
	11.39	63.2		470	510	800	900	1080	1250	1400	50	1750	2000	2000	
	13.95	51.6		470	560	800	900	1080	1250	1400	1750	1750	2000	2000	
	17.09	42.1		470	590	800	900	1080	1250	1400	1750	1750	2000	2000	
	20.93	34.4		470	620	800	900	1080	1250	1400	1750	1750	2000	2000	
	25.63	28.1		470	50	800	0	850	1250	600	1300	1750	2000	2000	
	31.39	22.9		180	210	150	360	180	390	670	1180	1200	1200	1200	
	38.44	18.7	180	270	260	500	440	740	900	1180	1200	1200	1200		
	47.08	15.3	180	270	330	540	600	800	900	1180	1200	1200	1200		
	57.67	12.5	180	270	370	540	600	800	900	1180	1200	1200	1200		
	70.62	10.2	180	270	370	540	600	800	900	1180	1200	1200	1200		
	86.5	8.3	100	140	180	270	290	470	600	800	900	1080	800		
	105.9	6.8	100	140	180	270	290	470	600	800	900	1080	1180		
	129.7	5.6	100	140	180	270	290	470	600	800	900	1080	1180		
	158.9	4.5	100	140	180	270	290	470	250	220	0	320	1180		
	194.6	3.7	100	140	180	270	290	470	420	450	450	750	1180		
	580	5.06	114.6	DOUBLE	470	70	750	270	1080	1250	1400	50	50	1000	800
6.2		93.5	470		190	770	20	1080	1250	1400	50	650	1700	1600	
7.59		76.4	470		470	790	100	1080	1250	1400	50	1600	2000	2000	
9.3		62.4	470		550	800	360	1080	1250	1400	50	1750	2000	2000	
11.39		50.9	470		610	800	900	1080	1250	1400	50	1750	2000	2000	
13.95		41.6	470		620	800	900	1080	1250	1400	1750	1750	2000	2000	
17.09		33.9	470		620	800	900	1080	1250	1400	1750	1750	2000	2000	
20.93		27.7	470		620	800	900	1080	1250	1400	1750	1750	2000	2000	
25.63		22.6	470		0	800	0	750	1250	600	1200	1750	2000	2000	
31.39		18.5	180		260	200	430	300	530	880	1180	1200	1200	1200	
38.44		15.1	180	270	300	540	530	800	900	1180	1200	1200	1200		
47.08		12.3	180	270	370	540	600	800	900	1180	1200	1200	1200		
57.67		10.1	180	270	370	540	600	800	900	1180	1200	1200	1200		
70.62		8.2	180	270	370	540	600	800	900	1180	1200	1200	1200		
86.5		6.7	100	140	180	270	290	470	600	800	900	1080	700		
105.9		5.5	100	140	180	270	290	470	600	800	900	1080	1180		
129.7		4.5	100	140	180	270	290	470	600	800	900	1080	1180		
158.9		3.7	100	140	180	270	290	470	200	200	0	300	1180		
194.6		3	100	140	180	270	290	470	400	400	400	700	1180		

† Capacities listed are for pure radial loads on a reducer. If overhung load exceeds the value shown or if overhung load is applied at the same time as thrust loads, consult DODGE Application Engineering.

■ Sizes 1-3 discounted remaining sotck may be available.



ENGINEERING/TECHNICAL

MAXUM Concentric Reducer

Table 24: Low Speed Overhung Loads

Approx. Low Speed Shaft RPM	Unit Red.	Overhung Load Capacity MAXUM Reducer Size (multiply value shown by 1000) †											
		1	2	3	4	5	6	7	9	10	11	12	
777.8	DOUBLE	1.38	1.94	2.29	2.87	3.69	4.84
636.4		1.43	2.05	2.37	2.96	3.87	5.07
519.3		1.54	2.16	2.52	3.12	4.08	5.33
423.7		1.41	2.1	2.64	3.17	3.98	5.39
345.8		1.47	2.19	2.78	3.32	4.18	5.65	7.05	10.3	10.3	12.2	10.4	
282.3		1.54	2.28	2.94	3.51	4.39	5.95	7.56	10.7	10.9	12.8	10.9	
230.6		1.62	2.32	3.13	3.70	4.66	6.29	7.48	11.2	11.5	13.4	11.3	
188.2		1.74	2.53	3.31	3.91	4.95	6.61	8.27	11.9	12.1	14.1	12.0	
153.6		1.90	2.74	3.48	4.14	5.27	6.98	8.97	12.5	12.7	14.9	12.7	
125.4		2.07	2.98	3.70	4.37	5.71	7.43	9.88	13.3	13.5	15.7	13.8	
102.4		2.26	3.24	3.92	4.63	6.16	7.78	10.9	14.1	14.2	16.6	14.9	
83.6		2.47	3.51	4.19	4.98	6.62	8.25	11.8	14.9	15.1	17.7	16.0	
68.3		2.70	3.79	4.47	5.46	7.13	8.66	13.1	15.8	16.0	19.4	17.5	
55.8		TRIPLE	2.91	4.08	4.85	5.86	8.03	9.64	14.6	16.9	17.5	21.7	19.6
45.5	3.16		4.40	5.22	6.31	8.51	10.2	15.4	18.2	18.5	22.6	21.0	
37.2	3.40		4.74	5.48	6.80	8.85	10.5	16.6	19.7	19.9	24.4	22.8	
30.4	3.55		4.78	5.48	6.98	8.88	10.5	17.8	20.0	21.8	26.5	24.8	
24.8	3.58		4.80	5.48	6.98	8.90	10.5	17.8	20.0	23.7	28.6	27.1	
20.2	3.58		4.80	5.48	6.98	8.95	10.6	17.9	20.0	24.6	29.5	29.4	
16.5	3.60		4.83	5.48	6.98	8.98	10.6	17.9	20.0	24.6	29.5	29.4	
13.5	3.60		4.85	5.48	6.98	9.00	10.6	17.9	20.0	24.6	29.5	29.4	
11.0	3.63		4.85	5.48	6.98	9.03	10.6	18.0	20.0	24.6	29.5	29.4	
9.0	3.63		4.85	5.48	6.98	9.05	10.7	18.0	20.0	24.6	29.5	29.4	

* Interpolate for intermediate values.

† Capacities are for pure radial loads.

If overhung loads are applied at the same time as thrust loads, consult DODGE Application Engineering.

• Consult DODGE.

Table 25: Actual Ratios

AGMA Nominal Ratio	Approx. Low Speed Shaft RPM	Unit Red.	Actual Ratio of Reduction MAXUM Reducer Size											
			1	2	3	4	5	6	7	9	10	11	12	
2.25	777.8	DOUBLE	2.253	2.259	2.263	2.225	2.263	2.273						
2.75	636.4		2.801	2.800	2.760	2.679	2.750	2.770						
3.37	519.3		3.406	3.373	3.364	3.320	3.338	3.392						
4.13	423.7		4.091	4.108	4.167	4.125	4.114	4.133						
5.06	345.8		5.087	5.091	5.081	4.966	5.000	5.037	5.065	5.103	4.958	5.104	5.089	
6.20	282.3		6.184	6.133	6.194	6.154	6.069	6.167	6.115	6.154	6.109	6.134	6.220	
7.59	230.6		7.639	7.484	7.813	7.586	7.520	7.680	7.527	7.478	7.589	7.552	7.464	
9.30	188.2		9.282	9.333	9.524	9.280	9.273	9.273	9.217	9.200	9.385	9.077	9.325	
11.39	153.6		11.28	11.30	11.33	11.45	11.37	11.37	11.21	11.20	11.33	11.28	11.31	
13.95	125.4		13.79	14.00	14.09	13.89	14.00	14.25	13.91	13.88	13.93	13.89	13.98	
17.09	102.4		16.87	17.18	17.13	17.00	17.14	16.86	17.47	17.14	16.73	16.90	16.90	
20.93	83.6		20.83	21.14	21.11	20.57	20.67	20.67	21.06	21.00	20.92	20.83	20.60	
25.63	68.3		25.64	25.67	25.32	26.18	25.20	24.67	25.68	25.60	25.89	25.32	25.59	
31.39	55.8		TRIPLE	30.90	30.96	31.28	31.50	31.38	32.00	30.50	30.68	31.61	31.29	31.21
38.44	45.5	37.77		38.35	38.88	38.21	38.64	40.11	37.83	38.03	38.86	38.51	38.60	
47.08	37.2	46.20		47.05	47.28	46.75	47.31	47.45	47.53	46.96	46.68	46.85	46.63	
57.67	30.4	57.05		57.91	58.27	56.57	57.04	58.17	57.29	57.52	58.36	57.77	56.85	
70.62	24.8	70.22		70.30	69.88	72.00	69.55	69.43	69.86	70.12	72.12	70.21	70.63	
86.50	20.2	85.73		85.91	85.52	86.86	86.81	86.21	86.27	86.94	85.07	86.60	86.36	
105.9	16.5	104.8		106.4	106.3	105.4	106.9	108.1	104	106.5	106.4	106.8	106.8	
129.7	13.5	128.2		130.5	129.3	128.9	130.9	127.8	126.8	129.8	131.6	129.8	129	
158.9	11.0	158.3		160.7	159.3	156	157.8	156.7	158.9	157.5	159.8	159.1	157.3	
194.6	9.0	194.8		195.1	191.1	198.5	192.4	187.1	193.8	192	197.7	193.4	195.4	

† Based on 1750 high speed shaft RPM.

• Sizes 1-3 discounted remaining sotck may be available.

FEATURES/BENEFITS PAGE G3-3	NOMENCLATURE PAGE G3-6	EASY SELECTION PAGE G3-7	SELECTION/DIMENSIONS PAGE G3-23
--------------------------------	---------------------------	-----------------------------	------------------------------------



MAXUM Concentric Reducer

Table 26: WR² Values

AGMA Nominal Ratio	Approx. † Low Speed Shaft RPM	Unit Red.	WR ² (lb. - In ²) at high Speed Shaft ★ MAXUM Reducer Size														
			1	2	3	4	5	6	7	9	10	11	12				
2.25	777.8	DOUBLE	10.22	17.02	42.06	77.41	125.4	253.9									
2.75	636.4		7.699	12.61	32	59.02	94.8	189.3									
3.37	519.3		6.11	9.869	24.59	43.48	73.97	141.5									
4.13	423.7		7.932	12.86	31.9	57.81	93.81	184.3									
5.06	345.8		6.217	9.901	25.17	45.49	73.42	142.4	309.3	768.4	1469	2529	4140				
6.2	282.3		5.107	8.004	19.99	34.67	59.45	110.3	259.9	611.2	1127	2008	3201				
7.59	230.6		4.24	6.408	15.55	26.33	46.29	82.57	205.8	487.2	868.0	1559	2559				
9.3	188.2		3.633	5.179	12.7	21.03	37.06	66.14	164.5	387.7	683.6	1272	1959				
11.39	153.6		3.158	4.344	10.73	16.09	29.44	50.6	133.1	309.6	558.5	1003	1564				
13.95	125.4		2.807	3.528	8.316	13	24.09	39.11	106.4	258.8	455.0	813.6	1234				
17.09	102.4		2.35	2.898	6.616	10.45	19.65	32.35	85.34	209.7	373.0	655.3	986.5				
20.93	83.6		2.017	2.466	5.406	8.541	17.24	25.92	72.74	173.7	298.5	525.0	784.6				
25.63	68.3		1.765	2.147	4.559	6.967	15.01	21.9	61.73	148.5	244.9	428.2	622.0				
31.39	55.8		2.196	3.322	5.609	8.648	11.88	19.57	48.58	106.9	185.8	337.9	493.5				
38.44	45.5		2.140	3.225	5.370	8.272	11.25	18.20	45.38	99.01	172.3	311.5	449.4				
47.08	37.2		2.099	3.158	5.208	7.972	10.73	17.42	42.93	93.41	163.0	293.2	419.0				
57.67	30.4	2.068	3.110	5.077	7.746	10.38	16.69	41.39	89.04	154.7	278.4	394.2					
70.62	24.8	2.046	3.073	4.985	7.549	10.11	16.18	40.11	86.03	148.5	267.6	374.5					
86.50	20.2	1.170	1.579	2.303	3.333	4.771	6.594	27.36	52.16	84.71	145.5	144.1					
105.9	16.5	1.163	1.566	2.271	3.284	4.689	6.406	26.89	50.89	82.20	141.2	138.4					
129.7	13.5	1.158	1.558	2.249	3.244	4.621	6.298	26.50	50.01	80.33	138.0	134.4					
158.9	11.0	1.154	1.552	2.232	3.214	4.576	6.197	22.60	40.82	62.58	107.0	131.2					
194.6	9.0	1.151	1.547	2.220	3.189	4.541	6.127	22.43	40.42	61.76	105.5	128.6					

★ For WR² at low speed shaft, multiply the WR² value listed by (actual ratio)². See Table 25 for actual ratios.

† Based on 1750 high speed shaft RPM.

■ Sizes 1-3 discounted remaining stock may be available.

FEATURES/BENEFITS PAGE G3-3	NOMENCLATURE PAGE G3-6	EASY SELECTION PAGE G3-7	SELECTION/DIMENSIONS PAGE G3-23
--------------------------------	---------------------------	-----------------------------	------------------------------------

ENGINEERING/TECHNICAL



MAXUM Concentric Reducer

CAUTION: Unit is shipped without oil. Add proper amount of recommended lubricant before operating. Failure to observe these precautions could result in damage to, or destruction of, the equipment.

Lubrication is extremely important for satisfactory operation. The proper oil level as shown in Table 29, page G3-77, must be maintained at all times. Frequent inspections with the unit not running and allowing sufficient time for the oil to cool and the entrapped air to settle out of the oil should be made by removing the level plug to see that the level is being maintained. If low, add the proper type and viscosity of lubricant through one of the upper openings until it comes out of the oil level hole. Replace the oil level plug securely. Refer to Table 27 and Table 28 below for viscosity recommendations.

After an initial operation of about two weeks, the oil should be changed. If desired, this oil may be filtered and reused. Very often, small metal particles will show up in the oil due to the wearing in process. After the initial break in period, the lubricant should be drained, magnetic drain plug cleaned, gear case flushed and refilled every 2500 hours of operation under average industrial conditions. More frequent oil changes are recommended when operating

continuously or at high temperatures or under conditions of extreme dirt or dust. Use only recommended lubricants listed on this page, or equivalent. Special attention should be given to checking of lubricants when any of the following conditions exist:

10. High operating temperatures resulting from heavy intermittent loads causing the temperature of the gear case to rise rapidly and then cool.
11. Unusual ambient conditions, which may tend to cause condensation on the inside of the gear case thereby contaminating the oil.
12. Operating temperatures that would cause oil to approach 200°F continually.
13. If the reducer is subjected to unusual vapors or moist atmosphere.

Operating Temperatures

Heating is a natural characteristic of enclosed gearing, and a maximum gear case temperature approaching 200°F is not uncommon for some units operating in normal ambient temperatures (80°F). When operating at rated capacity, no damage will result from this temperature as this was taken into consideration in the design of the gear case and in the selection of the lubricants.

Table 27: Lubrication Recommendations - ISO Grades for Ambient Temperatures of 50 thru 125 Degrees F *

Output RPM	MAXUM Reducer Size											
	1	2	3	4	5	6	7	9	10	11	12	
230	220	220	220	220	220	220	220	220	220	220	220	
190	320	320	220	220	220	220	220	220	220	220	220	
155	320	320	320	220	220	220	220	220	220	220	220	
125	320	320	320	320	320	220	220	220	220	220	220	
100	320	320	320	320	320	320	220	220	220	220	220	
84	320	320	320	320	320	320	220	220	220	220	220	
68	320	320	320	320	320	320	320	220	220	220	220	
56	320	320	320	320	320	320	320	320	320	320	220	
45	320	320	320	320	320	320	320	320	320	320	320	

* NOTES:

1. Use ISO 220 above 230 Output RPM.
2. Use ISO 320 below 45 Output RPM.
3. Assumes Auxiliary Cooling where Recommended in the Catalog.

Table 28: Lubrication Recommendations ISO Grades For Ambient Temperatures Of 15 Thru 60 Degrees F*

Output RPM	MAXUM Reducer Size											
	1	2	3	4	5	6	7	9	10	11	12	
230	150	150	150	150	150	150	150	150	150	150	150	
190	220	220	150	150	150	150	150	150	150	150	150	
155	220	220	220	150	150	150	150	150	150	150	150	
125	220	220	220	220	220	150	150	150	150	150	150	
100	220	220	220	220	220	220	150	150	150	150	150	
84	220	220	220	220	220	220	150	150	150	150	150	
68	220	220	220	220	220	220	220	150	150	150	150	
56	220	220	220	220	220	220	220	220	220	220	150	
45	220	220	220	220	220	220	220	220	220	220	220	

* NOTES:

1. Use ISO 150 above 230 Output RPM.
2. Use ISO 220 below 45 Output RPM.
3. Assumes Auxiliary Cooling where Recommended in the Catalog.

Lubricant Grade Equivalents

ISO	AGMA
150	4
220	5
320	6

NOTE: Mobile SHC 630 Series oil is recommended for high ambient temperatures. For a wide range of ambient temperatures (-10 F/120 F) use Mobile SHC 629,

FEATURES/BENEFITS PAGE G3-3	NOMENCLATURE PAGE G3-6	EASY SELECTION PAGE G3-7	SELECTION/DIMENSIONS PAGE G3-23
--------------------------------	---------------------------	-----------------------------	------------------------------------



MAXUM Concentric Reducer OIL LEVEL LOCATIONS FOR POSTION A-1

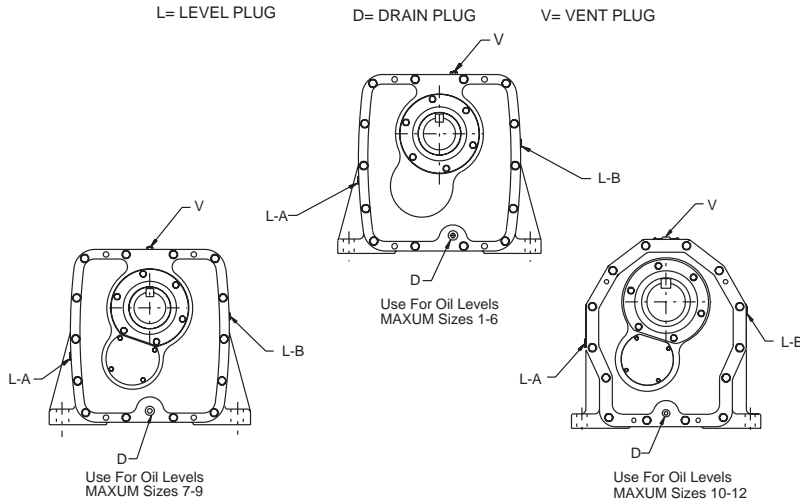

**Table 29: Approximate Oil Capacities And Oil Levels*
VS Output RPM'S For Floor Mounted Position**

MAXUM Size	Output RPM	Approximate Oil Capacity	Level Position
1	ABOVE 375 BELOW 375	2.8 QUARTS 5.2 QUARTS	L-AL-B
2	ABOVE 355 BELOW 355	4.1 QUARTS 7.3 QUARTS	L-AL-B
3	ABOVE 300 BELOW 300	6.5 QUARTS 12.0 QUARTS	L-AL-B
4	ABOVE 270 BELOW 270	9.0 QUARTS 16.6 QUARTS	L-AL-B
5	ABOVE 250 BELOW 250	10.9 QUARTS 21.2 QUARTS	L-AL-B
6	ABOVE 215 BELOW 215	15.7 QUARTS 30.7 QUARTS	L-AL-B

MAXUM Size	Output RPM	Approximate Oil Capacity	Level Position
7	ABOVE 175 BELOW 175	8.3 GALLONS 17.6 GALLONS	L-AL-B
9	ABOVE 140 BELOW 140	12.6 GALLONS 27.2 GALLONS	L-AL-B
10	ABOVE 120 BELOW 120	12.9 GALLONS 29.8 GALLONS	L-AL-B
11	ABOVE 110 BELOW 110	16.3 GALLONS 36.9 GALLONS	L-AL-B
12	ABOVE 95 BELOW 95	20.0 GALLONS 42.5 GALLONS	L-AL-B

* Always fill to the oil plug regardless of the stated quantities. Refer to instruction manual for more information.

The lubrication instructions on pages G3-76 and G3-77 are offered for general guidelines. Refer to the instruction manual shipped with the reducer for specific lubrication instructions

FEATURES/BENEFITS PAGE G3-3	NOMENCLATURE PAGE G3-6	EASY SELECTION PAGE G3-7	SELECTION/DIMENSIONS PAGE G3-23
--------------------------------	---------------------------	-----------------------------	------------------------------------



MAXUM Concentric Reducer

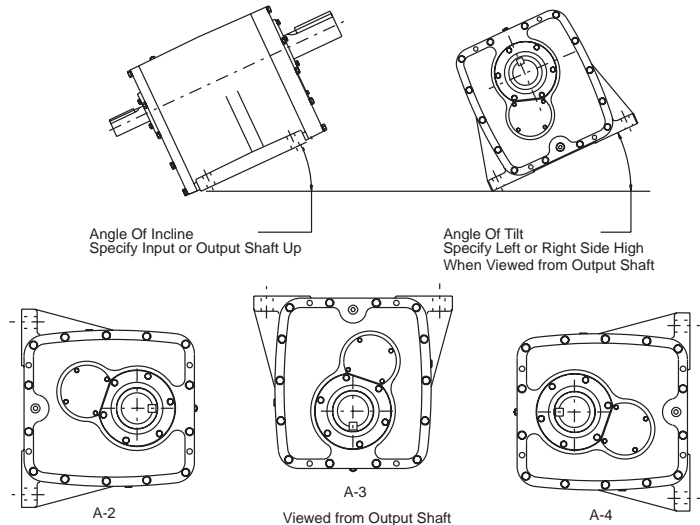

DODGE MAXUM Concentric Shaft Reducers can be modified to permit mounting in positions other than the conventional (A-1) floor mounting. Some of these include ceiling (A-3) and wall (A-2 and A-4) and various inclined, vertical and tilted positions. Consult DODGE to determine what modifications are required for your specific application.

In order for DODGE to make recommendations on the required modifications, the following information must be provided:

- Reducer Size.
- Ratio.
- Input and/or output speed.
- Transmitted Horsepower.
- Duty cycle. Continuous or intermittent operation. If intermittent, running time vs. idle time.
- Mounting position, such as A-2, A-3 or A-4 with shafts level, or a more complete description of the mounting arrangement including the angle of tilt of the housing, the incline of the shafts and whether the output shaft is higher or lower than the input shaft.



MAXUM Concentric Reducer Vertical And Inclined Application

When the reducer is mounted vertically, the upper bearings will not receive adequate lubrication from normal means of splash lubrication. The MAXUM reducer design uses a center web in the housing to support the inside bearings. This center web becomes a splash baffle when the reducer is mounted in a vertical position so other alternatives for lubrication need to be considered.

The MAXUM solution to this problem is to use a Nylos Ring - a thin dish or cup mounted between the shaft shoulders and the Timken cone (see Drawing A). The purpose of this cup is to hold a reservoir of grease to lubricate the upper bearings. If the low speed shaft is up, we provide this modification for both the low speed pinion bearing and the countershaft bearing.

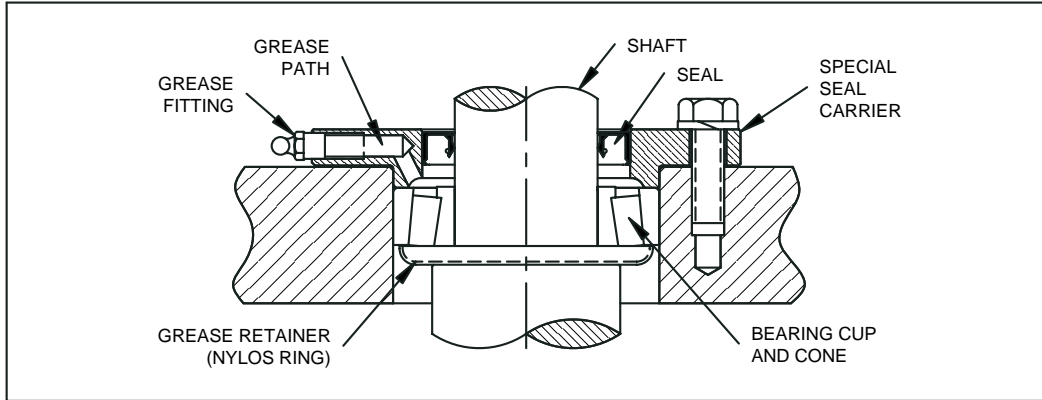

DRAWING A

In addition to the Nylos Ring, we provide a means to initially charge and replace the grease reservoir. The seal carrier of the housing is drilled, and a grease fitting is provided to maintain a level of lubricant in this cavity. Lubrication of the upper gearset also needs to be

considered, and this is provided for by increasing the lubricant level to make contact with the upper gearset. We provide this information for each application, by a drawing similar to Drawing B below.

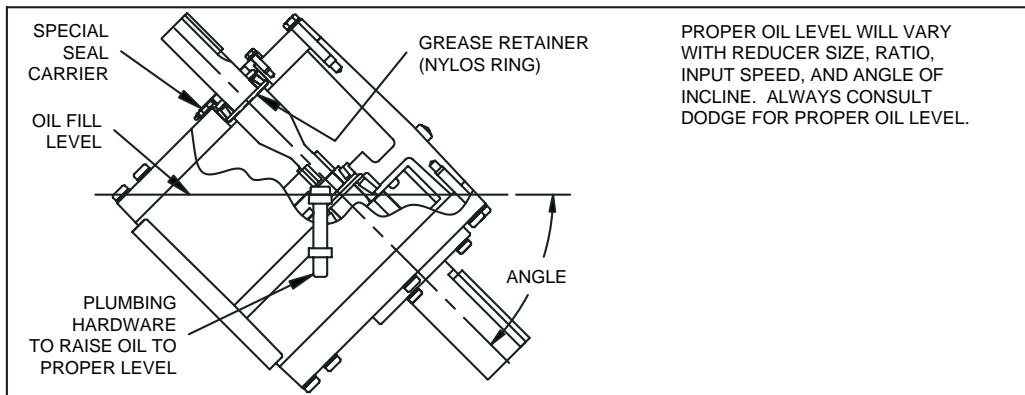

DRAWING B

FEATURES/BENEFITS PAGE G3-3	NOMENCLATURE PAGE G3-6	EASY SELECTION PAGE G3-7	SELECTION/DIMENSIONS PAGE G3-23
--------------------------------	---------------------------	-----------------------------	------------------------------------

ENGINEERING/TECHNICAL



MAXUM Concentric Reducer Vertical And Inclined Application

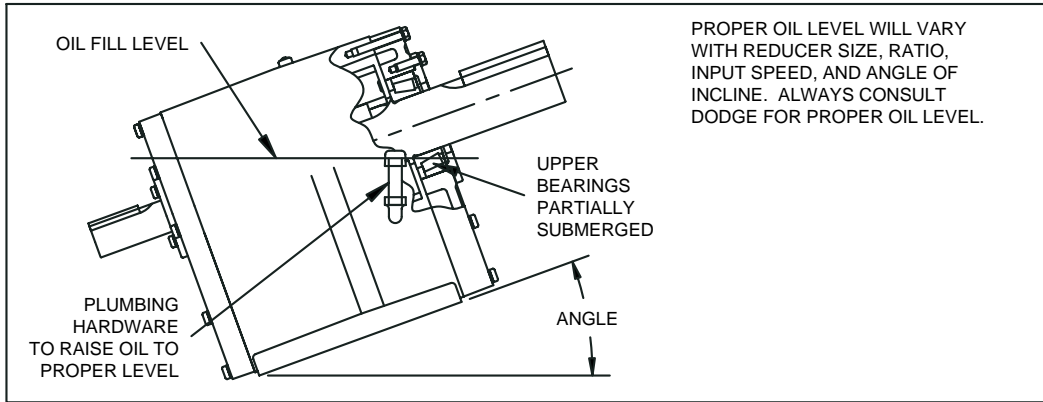

PROPER OIL LEVEL WILL VARY WITH REDUCER SIZE, RATIO, INPUT SPEED, AND ANGLE OF INCLINE. ALWAYS CONSULT DODGE FOR PROPER OIL LEVEL.

DRAWING C

We are frequently asked at what angle of incline should the vertical modification be considered. On the list price modification page, we state “exceeding 10° of incline”. This is conservative and would provide the lubrication required at very slow output speeds where there would be minimum splash generated. If the MAXUM reducer is operating at moderate to high speed, this minimum guideline may be increased. See Drawing C.

Another area where special lubrication needs to be considered is “tilt mounting”. The input and output shafts are horizontal but the reducer may be mounted in an A-2, A-3 or A-4 position or at some angle in between. The solution for this type of mounting is one of using the proper oil level only (no modification needed). Drawing D illustrates the use of a standpipe to meet oil level requirements.

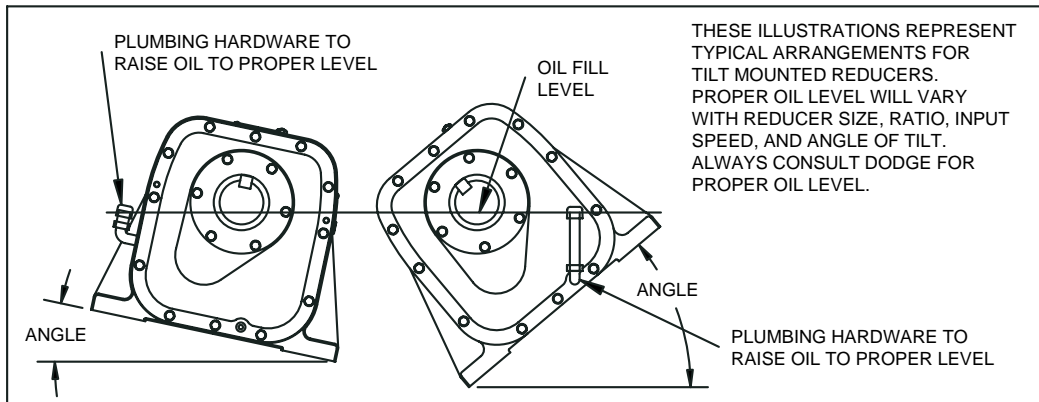

THESE ILLUSTRATIONS REPRESENT TYPICAL ARRANGEMENTS FOR TILT MOUNTED REDUCERS. PROPER OIL LEVEL WILL VARY WITH REDUCER SIZE, RATIO, INPUT SPEED, AND ANGLE OF TILT. ALWAYS CONSULT DODGE FOR PROPER OIL LEVEL.

DRAWING D

FEATURES/BENEFITS PAGE G3-3	NOMENCLATURE PAGE G3-6	EASY SELECTION PAGE G3-7	SELECTION/DIMENSIONS PAGE G3-23
--------------------------------	---------------------------	-----------------------------	------------------------------------



MAXUM Concentric Reducer GENERAL GUIDELINES FOR MOUNTING VARIABLE SPEED AC OR DC MOTORS AMPLITUDE RATIO

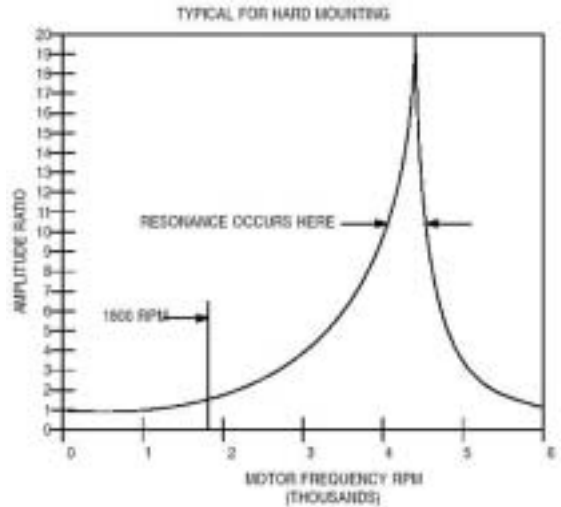
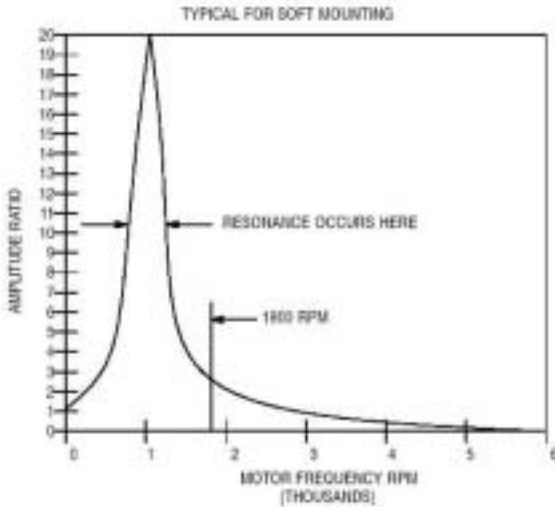

DEFINITIONS:

FUNDAMENTAL NATURAL FREQUENCY is the lowest number of times per minute that the motor and supporting structure will maintain a periodic oscillation, once displaced, under the sole influence of its own mass and stiffness.

RESONANCE is a vibration of large amplitude caused by the small periodic stimulus of the unbalance force when the motor speed is the same or nearly the same frequency as

the fundamental natural frequency of the motor and support structure.

SOFT MOUNTING - The fundamental natural frequency is below the motor operating speed.

HARD MOUNTING - The fundamental natural frequency is above the motor operating speed.

(Continued on page G3-82)

FEATURES/BENEFITS PAGE G3-3	NOMENCLATURE PAGE G3-6	EASY SELECTION PAGE G3-7	SELECTION/DIMENSIONS PAGE G3-23
--------------------------------	---------------------------	-----------------------------	------------------------------------

ENGINEERING/TECHNICAL



MAXUM Concentric Reducer

GENERAL GUIDELINES FOR MOUNTING VARIABLE SPEED AC OR DC MOTORS

SCOOP MOUNT ACCESSORY

1. This is a soft mounting of the motor.
2. The benefits obtained by using this accessory are low cost and isolation of the reducer support structure from the motor vibration.
3. This motor mount was designed for use with a constant speed motor at 1750 RPM. Use of motors with lower base speeds increases the chance of producing resonance. Stiffening techniques within the scoop structure can increase the fundamental natural frequency about 20% which is generally enough to eliminate resonance should it occur.
4. This accessory is NOT recommended for variable speed DC or AC applications.
5. Customers who prefer to use the scoop mount accessory to mount variable speed AC or DC motors must state on the face of the purchase order that they plan to support scoop and assume full responsibility for any vibratory or transient load induced by the motor. For recommended scoop support, contact Reliance Electric and reference drawing #A31512.

NOTE: For more information on DODGE MAXUM Concentric Reducer Scoop Mount Reducers, refer to page G3-41.

TOP MOUNT ACCESSORY

1. This may be a soft or hard mounting of the motor depending on the size of the motor and the distance that the adjusting screws are extended.

2. The benefits obtained by using this accessory are low cost, minimum floor space used for the motor/reducer assembly, and greater flexibility to obtain the required output RPM of the reducer than concentric coupling.
3. This motor mount was designed for use with a constant speed motor at 1750 RPM.
4. This accessory is NOT recommended for variable speed DC or AC applications. Consult Reliance.

NOTE: For more information on DODGE MAXUM Concentric Reducer Motor Mounts, refer to pages G3-51 through G3-52.

HD BASEPLATE ACCESSORY

1. This is a hard mounting of the motor.
2. The benefits obtained by using this accessory are:
 - a. resonance problems are minimized
 - b. accurate assembly of motor/coupling/reducer can be done at the factory instead of the job site. Note: Alignment must always be rechecked at job site prior to start-up.
 - c. large motors can be rigidly mounted to keep deflection under control and provide longer service life.
3. This accessory is recommended for large motors where the motor weight exceeds the reducer weight or 700 lbs., and for variable speed DC or AC applications regardless of the motor weight. For mounting dimensions see page G3-39.

NOTE: For more information on DODGE MAXUM Concentric Reducer HD Baseplates, refer to pages G3-38.

TIGEAR-2™ Catalog

Features / Benefits	G4-2
E-Z KLEEN	G4-5
Helical Attachment	G4-7
Specification	G4-8
How To Order / Nomenclature	G4-9
Selection	G4-10
Selection / Dimensions	
Size 13	G4-16
Size 15	G4-22
Size 17	G4-28
Size 20	G4-36
Size 23	G4-44
Size 26	G4-50
Size 30	G4-56
Size 35	G4-62
Size 40	G4-68
Size 47	G4-74
Washdown Products	G4-80
Helical Attachment	G4-86
Mounting Positions	G4-88
Modifications / Accessories	G4-90
Engineering Technical	G4-109
Renewal Parts	G4-112
Part Number Index	INDEX-1
Keyword Index	INDEX-27

TIGEAR-2 Electronic Data

www.dodge-pt.com

- All Catalog Pages
- 2-D And 3-D Drawings
- Instruction Manual
- Accessory Kit Installation Instructions
- Brochure

FEATURES / BENEFITS

TIGEAR-2

- 10 Case Sizes
- 1.33" to 4.75" Center Distances
- 5:1 to 60:1 Reductions
- Quill Input
- Separate Input
- 3-Piece Coupled Input
- Solid Output
- Hollow Output

On average, TIGEAR-2 delivers more torque than competitive, same-sized models. This permits downsizing and helps reduce total cost of ownership.

TIGEAR-2 reducers share the same footprint and most critical mounting dimensions with original TIGEAR and many competitive models.

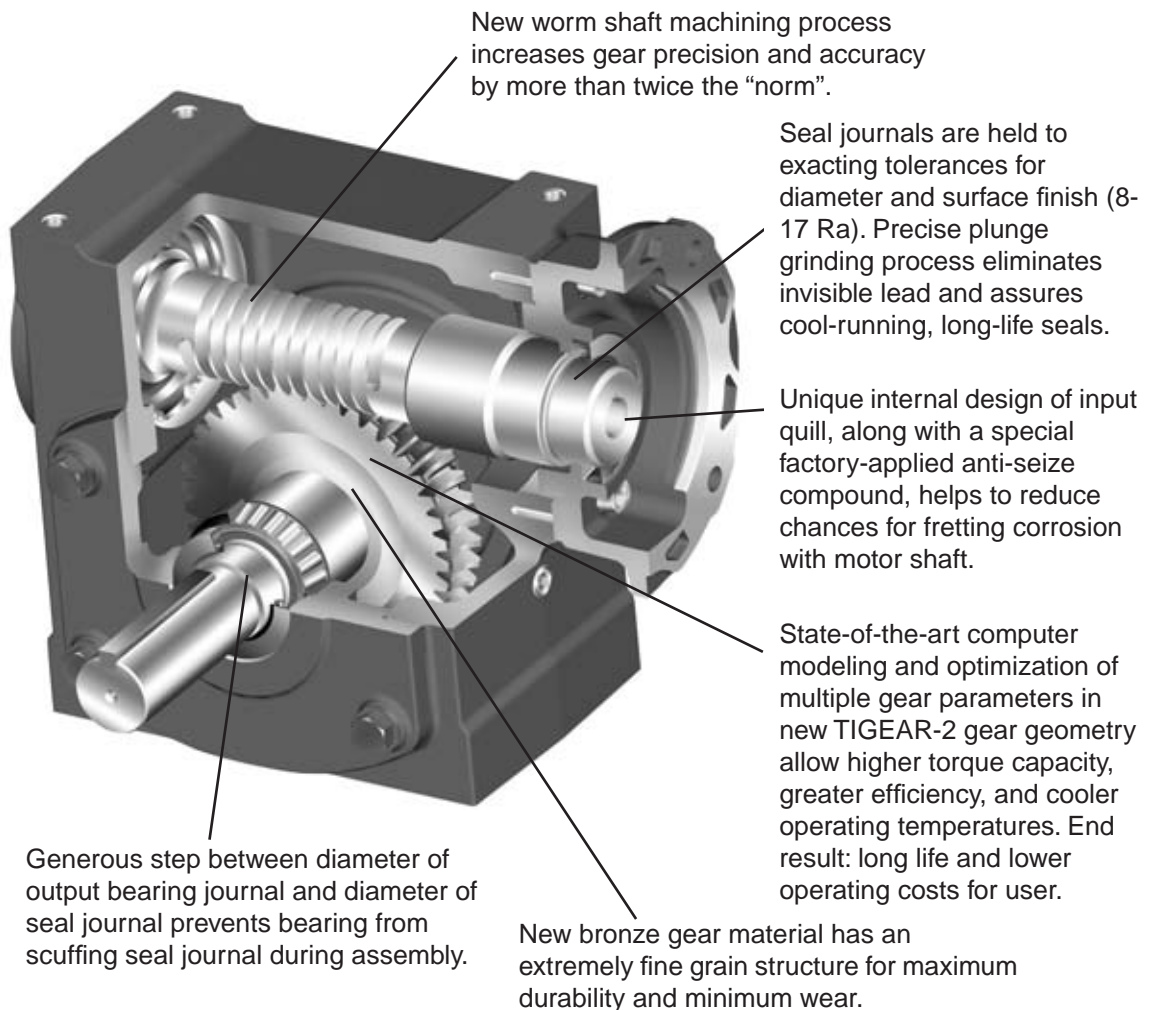

TIGEAR-2

CONFIGURATION OPTIONS

The advanced design concept of the TIGEAR-2 reducer product line provides extreme flexibility for applications that require from 100 to more than 6,800 lb.-in of torque. Whether the application requires the compactness of a quill-style input, the durability of a three-piece coupled input, or a separate keyed input shaft for belt-driven equipment, TIGEAR-2 is the answer. With four basic reducer configurations that are dimensionally interchangeable with most competitive brands and stock, and bolt-on accessories, the TIGEAR-2 reducer line is truly a complete line that is full of value.



Quill Input

Space-saving quill-style input reducers for NEMA C-face motors in both solid and hollow output designs



Separate Input

Separate style input reducers with solid or hollow output shafts are suitable for either belted or direct-coupled motor connections



Three-Piece Coupled Input

Attaching a stock, three-piece coupled motor adapter kit to a separate style reducer creates a durable drive package that facilitates easy motor removal and provides protection against shock loads and other unpredictable vibrations



FEATURES / BENEFITS

TIGEAR-2

New TIGEAR-2 Sealing System

The new totally enclosed, ventless sealing system operates effectively with no pressure vent, no compression chamber. TIGEAR-2 contains a new factory-filled synthetic lubricant that actually runs cooler, as well as eliminates the need for routine oil changes. All reducers are filled with the proper amount of lubricant for any approved mounting position. Simply install it, then forget it.

New Custom-Formulated HNBR Wave Seal

Hydrogenated Nitrile Butadiene Rubber (HNBR) material has been proven to be a better all-round choice for oil compatibility, wear, and temperature range. Overall, it provides up to 6 times greater wear resistance than industry standard nitrile seals.

Special Hydrodynamic Wave Seal Design

The special wave shape (molded into the seal lip) generates a better hydrodynamic film, which is required between the seal and the shaft for long life. This special wave design generates less drag, less heat, and virtually eliminates shaft grooving created by the single-point wear track, which is common with conventional trimmed lip seal designs. The sinusoidal lip of the wave seal

effectively pushes external contaminants away and pumps lubricant back into the oil sump.

Special Lip Construction

Optimized lip-to-shaft contact pressures ensure maximum life. In addition, special sealing elements operate under pressure without detrimental effect on service life or sealing performance.

New Factory-Filled Synthetic Lubricant

The standard synthetic lubricant used in TIGEAR-2 meets H1 food grade requirements and accommodates a wide range of operating temperatures. In extensive laboratory test, it lowered operating temperatures by 20° F over other popular synthetics. No routine scheduled oil changes are required.

New GRIP TIGHT™ Tapered Adapter Bushing System

Eliminates Hop and Wobble



Locking System

The TIGEAR-2 reducer's new GRIP TIGHT tapered bushing system uses concepts that have proven to be effective in the locking mechanism of the DODGE GRIP TIGHT bearing to simplify installation and removal and prevent fretting corrosion problems. There are no loose fasteners to misplace during installation, and the locking nut creates a positive means for easy removal.

Minimum Shaft Length

The system's tapered bushings allow for mounting in some of the tightest places on almost any size shaft. (Driven shafts need not protrude completely through the reducer bore.)

Bushing Options

When used in pairs, the new tapered bushings can be used without output keys. Corrosion resistant options are available for severe washdown applications.

TIGEAR-2 E-Z KLEEN Reducer

DODGE E-Z KLEEN Reducers.

The best choice for food and beverage industries

Selected as a winner in Plant Engineering magazine's *Product of the Year* competition, the Dodge TIGEAR-2 reducer is now available with superior corrosion resistance and sealing to meet the harsh washdown applications associated with the food and beverage industry.

E-Z KLEEN TIGEAR-2 includes features never before offered with washdown reducers.

Standard Features Include:

- A 13-step coating system which provides greater than three times the corrosion resistance of standard epoxy painted units
- Factory filled H1 Food Grade synthetic lubrication
- Stainless color top coat. White finish also available.
- Stainless Steel solid or hollow output shafts
- 2-piece harsh duty output seals
- Stainless Steel hardware



Above: GRIP TIGHT Bushing

- Available in sizes 13 through 35 in Quill and 3-piece coupled input with solid or hollow output configurations.
- Accommodates 1/4 hp to 10 hp and ratios 5:1 to 60:1

Washdown Accessories include:

- Stainless Steel Grip Tight Bushings
- Bolt-on base
- Riser block kit
- J-mount kit
- Output flange kit

The advanced design concept of the TIGEAR-2 reducer product line delivers up to 30% higher ratings than competitive, same sized models. This permits downsizing and helps reduce total cost of ownership.

All TIGEAR-2 reducers include premium features the competition doesn't offer. These include a totally enclosed, ventless sealing system. A new factory filled synthetic lubricant that runs cooler, as well as eliminates the need for routine oil changes. Simply install it, then forget it.

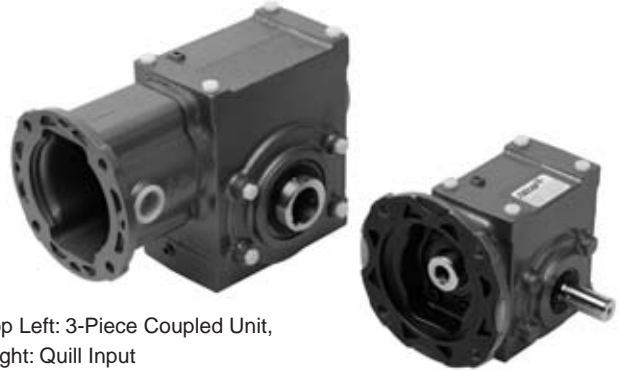

Top Left: 3-Piece Coupled Unit, Right: Quill Input

New Stainless Steel Grip Tight Bushings

The TIGEAR-2 reducer's new Grip Tight tapered bushing system provides simple installation and prevents fretting corrosion problems. Grip Tight bushings also minimize a condition called hop and wobble that is commonly associated with shaft mount reducers where the reducer moves up and down or side-to-side as the customer shaft rotates.

New Sealing System for DODGE E-Z KLEEN TIGEAR-2 Reducers:

To ensure that the interior of the reducer is as protected as the exterior, each E-Z KLEEN TIGEAR-2 reducer comes standard with a two-piece harsh duty sealing system that out high pressure sprays and sanitizing solutions. See TIGEAR-2 Harsh Duty Seal, page G4-6.



Refer to G4-80 thru G4-83 for selections

FEATURES / BENEFITS

TIGEAR-2 E-Z KLEEN Reducer TIGEAR-2 Harsh Duty Seal

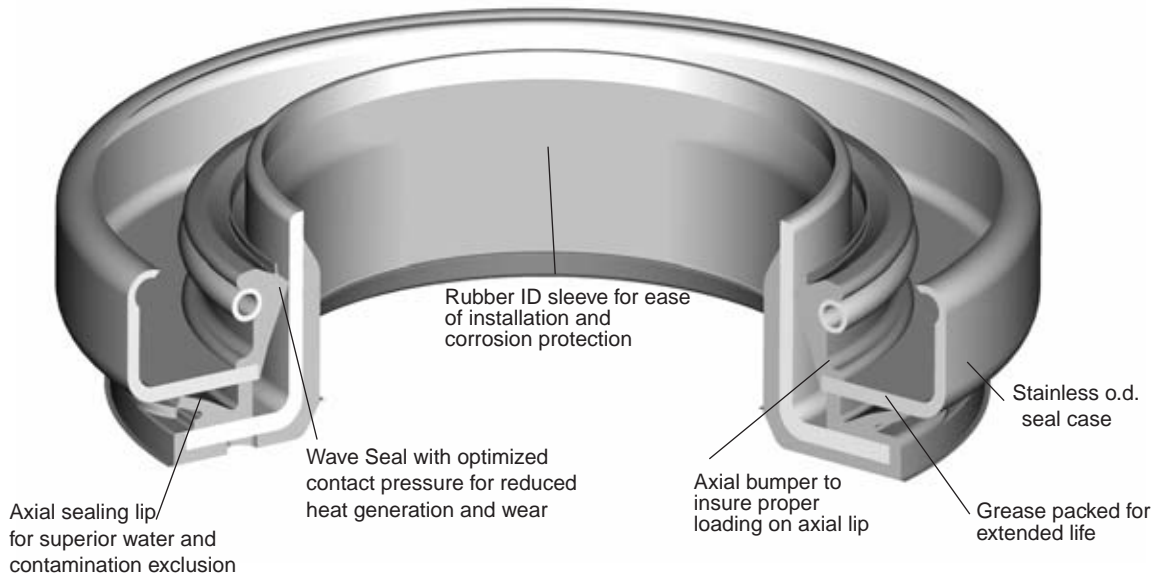

TIGEAR-2 STAINLESS STEEL ULTRA™ KLEEN REDUCER

Available by June 2005

The best choice for ultimate washdown protection or where “paint free” specification is required. Available in sizes 17, 23, 30, 35 with quill or 3-piece coupled input and solid or hollow output configurations.

Standard Features Include:

- Premium 316 Stainless Steel Housings
- Stainless Steel solid or hollow output shafts
- Stainless Steel hardware
- 2-piece harsh duty output seals
- Factory filled H1 food grade synthetic lubrication

Available Options Include:

- Stainless Steel Grip Tight and straight bore bushings
- Stainless Steel bolt-on base kit
- Stainless Steel output flange kit

For Selections, Refer To Pages G4-84 And G4-85.

FEATURES / BENEFITS

TIGEAR-2 Reducer HELICAL ATTACHMENT

A new, double NEMA 56 C-face helical gear attachment is now available for Tigear-2 reducers, providing gear ratios from 75:1 to 300:1.

The new helical attachment has a unique integral jaw coupling that has the compact assembly length of a quill with the advantages of a coupled assembly. It easily attaches to a Tigear-2 reducer with 56C quill or 3-piece coupled input.

- NEMA 56 C-face input and output
- Available in 4:1 and 5:1 ratios
- Factory filled with food grade synthetic lubricant
- Lubed for life
- No breather
- Suitable for all mounting positions right out of the box
- Hardening and ground gearing for smooth, quiet operation

With the helical attachment, customers can now take advantage of all the Tigear-2 features with available ratios up to 300:1.

Selected as a winner in Plant Engineering magazine's Product of the Year competition, the advanced design concept of the Tigear-2 reducer product line delivers up to 30% higher ratings than competitive, same sized models. This permits downsizing and helps reduce total cost of ownership.

All Tigear-2 reducers include premium features the competition doesn't offer. These include a totally enclosed, ventless sealing system. A new factory filled synthetic lubricant that runs cooler, as well as eliminates the need for routine oil changes. Simply install it, then forget it.

**For Selection And Dimensions Refer To
Pages G4-86 And G4-87**





SPECIFICATION

General Specification -DODGE TIGEAR-2 Speed Reducers

The speed reducer shall be a single reduction worm gear reducer incorporating three input configurations - a quill style for direct attachment of electric motors, a separate keyed input shaft suitable for flexible coupling to a footed motor or belt and pulley input configuration and a motor adapter style input that employs a three piece coupling to connect electric motors to the reducer. These input configurations shall be available in both solid and hollow output shaft designs. The reducer shall be manufactured in the United States of America.

- Worm gear geometry shall be highly optimized for rating and efficiency and precision manufactured with a single enveloping design.
- The gear set shall consist of a hardened steel worm shaft. The worm gear shall be a fine grain, copper-tin bronze -specially alloyed for superior durability and wear resistance. All units shall have the worm gear set properly centered during assembly to produce an optimum contact pattern.
- Gear design and power transmission ratings conform to globally accepted rating standards.
- The gear case and bearing housing shall be manufactured from Class 30 gray iron. The optional bolt-on base, motor flange and other accessories shall be available in either cast iron, aluminum or steel.
- A riser block kit, designed for mounting to the top surface, shall be available to provide a method for avoiding a mounting arrangement that would position the input shaft below the level of the output shaft.
- The reducer shall be sealed with no direct passage from the oil sump to the ambient atmosphere - (a closed system). This ventless design ensures no contamination of lubricant from external environment.
- All reducers shall be factory filled by the manufacturer with the proper volume of synthetic lubricant so that the reducer can be applied in any approved mounting position without any modifications to the reducer.
- The standard lubrication shall be a synthetic type that is suitable for USDA Class H1 environments. The manufacturer must state in writing that the lubrication shall require no periodic changing. Alternate synthetic lubricants made from the same base material as the standard shall be available to accommodate extreme temperature applications.
- Output shafts shall incorporate tapered roller bearings shimmed for proper running clearances and be designed for maximizing over hung load rating.
- Oil seals shall be made of premium materials and shall operate on plunge ground seal journals having an 8-17 Ra, 65-115 Rz micro finish. Seals made using Nitrile or Fluoroelastomer materials are not acceptable.
- Oil seals shall have a minimum temperature range of -40° to 300° F. (-40° to 149° C).
- All sealing-joints, except fill plug, shall be o-rings. Reducers shall incorporate no silicone rubber sealant of any kind.
- All fasteners shall be minimum Grade 5 and have locking provisions. Motor mounting bolts and input/output keys shall be provided.
- When properly service factored to account for the thermal limitations of the reducer, the standard construction shall be suitable for use in ambient temperatures from -10° F to +165° F.
- The thermal ratings listed on selection pages are based on the gear unit continuously operating in an ambient temperature of 75° F. For the ambient condition above 75° F, the derating factor table on page 8 needs to be applied to the thermal rating, or contact DODGE Application Engineering.
- When used without the optional aluminum bolt-on foot the reducer shall be BISSC certified.
- Severe washdown operating environments shall be addressed with a special coated gear case incorporating stainless steel hardware and stainless steel output shaft.

FEATURES/BENEFITS PAGE G4-2	NOMENCLATURE PAGE G4-9	SELECTION / DIMENSION PAGE G4-16	MODIFICATION PAGE G4-90
--------------------------------	---------------------------	-------------------------------------	----------------------------

HOW TO ORDER TIGEAR-2 REDUCERS

All TIGEAR-2 reducers and accessories have a part number. Reducer part numbers are found in the selection tables and accessories are listed in the modification section. When placing an order specify the reducer part number and part number(s) of selected accessories.

Part Number Example:

30Q15L14 Size-30, Quill input, 15:1 ratio, left hand output, 140TC input
 30BASE Size-30 Bolt-on base kit

TIGEAR-2 units are stocked in input configurations - Quill & Separate (keyed input shaft). Separate units have the same structure as the old Adaptable TIGEAR. That is, a basic reducer plus a motor adapter kit ordered under its own part number and shipped individually. The "A" Input Style designation below indicates that the motor adapter will be attached by DODGE to a Separate reducer prior to shipping on a made-to-order basis, for a nominal charge.

REDUCER NOMENCLATURE AND PART NUMBER

Size	Input Style	Washdown Option	Ratio	Output	Motor Frame
13 = 1.33 c.d. 15 = 1.50 c.d. 17 = 1.75 c.d. 20 = 2.00 c.d. 23 = 2.31 c.d. 26 = 2.62 c.d. 30 = 3.00 c.d. 35 = 3.50 c.d. 40 = 4.00 c.d. 47 = 4.75 c.d.	Q Quill S Separate A Adapter Assy 3 piece coupled style	Z E-Z KLEEN S ULTRA KLEEN	05 07 10 12 15 18 20 25 30 40 50 60	L R LR H HA	56 = 56C 14 = 140TC 18 = 180TC 21 = 210TC 25 = 250TC

OUTPUT SHAFT CONFIGURATIONS

HA (Hollow-Alternative)

EXAMPLE

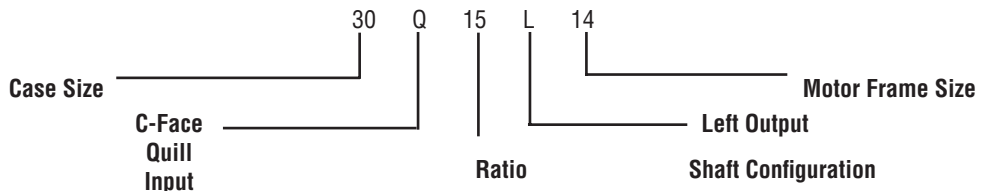



SELECTION

TIGEAR-2 Reducers

SELECTION USING RATING TABLES

Because the efficiency of worm gear speed reducers varies from approximately 60 to 95%, it is important to consider the horsepower/torque conditions at both input and output in a given application. In a situation where motor horsepower is known (e.g., competitive interchange or when a particular motor is available), selection can be done based on input ratings. Where a gearbox is being selected by a designer who knows driven equipment loads, the reducer is selected from the output torque capacity.

NOTE: Although many customers successfully use quill style reducers for the application listed below, we recommended using 3-piece coupled reducers. This will minimize any unusual noise conditions or aggravated wear in the input quill.

- Input speeds in excess of 2500 RPM
- Use of single phase motors
- Frequent starts and stops, more than 10 per hour
- Brakemotor applications
- Variable speed motors
- Clutch/Brake units

Reducer Service Factors

Prime Mover	Duration of Service Per Day	Driven Machine Load Classification		
		Uniform	Medium Shock	Heavy Shock
Electric Motor	Occasional 1/2 hour	Note (1)	Note (1)	1.00
	Less than 3 hours	1.00	1.00	1.25
	3 - 10 hours	1.00	1.25	1.50
	Over 10 hours	1.25	1.50	1.75
Electric Motor With Up To 10 Starts And Stops Per Hour (Note 2)	Occasional 1/2 hour	Note (1)	1.00	1.25
	Less than 3 hours	1.00	1.25	1.50
	3 - 10 hours	1.25	1.50	1.75
	Over 10 hours	1.50	1.75	2.00

Overhung Load

To determine overhung load, divide the torque required by the pitch radius of the sprocket, sheave, etc. and multiply by the appropriate factor as follows.

Chain drive	1.00
Synchronous Belt Drive	1.30
Spur or Helical Gear	1.25
V-Belt	1.50
Flat Belt	2.50

The calculated overhung load must not exceed the output overhung load rating.

For loads acting at more than one shaft diameter from the seal face use the following conversion factors:

Distance in Shaft Diameters from Output Seal Face	Multiply Overhung Load Capacity by this Factor
1D	1.00
2D	0.62
3D	0.42
4D	0.32
5D	0.26

Thermal Rating

Ambient Temp, degree F	Derating Factor
75	1.00
90	.87
100	.79
110	.71
120	.62

The thermal ratings listed on selection pages are based on the gear unit continuously operating in an ambient temperature of 75° F. For the ambient condition above 75° F, the derating factor needs to be applied to the thermal rating, or contact DODGE Application Engineering.

FEATURES/BENEFITS PAGE G4-2	SPECIFICATION PAGE G4-8	NOMENCLATURE PAGE G4-9	MODIFICATION PAGE G4-90
--------------------------------	----------------------------	---------------------------	----------------------------

TIGEAR-2 Reducers

HORSEPOWER METHOD OF SELECTION

- Step 1: **Determine Service Factor** Referring to the reducer service factor table, determine the appropriate service factor.
- Step 2: **Determine Equivalent Horsepower**
Multiply the motor horsepower by the service factor obtained in Step 1.
- Step 3: **Calculate Required Ratio** Divide the motor shaft rpm by the reducer output shaft rpm.
- Step 4: **Determine Unit Size** Refer to the rating tables and read across from ratio row and down from motor rpm column to select a unit whose **mechanical** input horsepower rating meets or exceeds the equivalent horsepower.
- Step 5: **Check Thermal Rating** Compare the thermal input horsepower rating of the reducer selected to the motor horsepower. Thermal rating should always equal or exceed applied motor horsepower. For continuous duty operation in ambient temperature above 75°F derate the thermal rating per table on page G4-8 or contact DODGE Engineering.
Contact DODGE Engineering for use with non-ventilated motors.

- Step 4: **Determine Unit Size** Refer to the rating tables and read across from ratio row and down from motor rpm column to select a unit whose **mechanical** output torque rating meets or exceeds the equivalent torque.
- Step 5: **Determine Required Motor Horsepower**
First, calculate the output horsepower using the following equation where output torque is the torque required to drive the load at the output of the reducer.

$$\text{Output HP} = \frac{\text{Output Speed} \times \text{Output Torque}}{63025}$$

Then calculate the required motor horsepower using the following equation to account for reducer efficiency:

$$\text{Required Motor Horsepower} = \frac{\text{Output Hp} \times \text{Rated Input Hp of reducer}}{\text{Rated output Hp of reducer}}$$

- Step 6: **Select Motor Hp** From available motors, select a horsepower that is equal to or greater than the value from Step 5: When the nearest motor horsepower is greater, check service factor at input by dividing rated input of reducer horsepower by actual motor horsepower. If the service factor is less than the value from Step 1, a larger reducer may be required.
- Step 7: **Check Thermal Rating** Compare the thermal input horsepower rating of the reducer selected to the motor horsepower. Thermal rating should always equal or exceed applied motor horsepower. For continuous duty operation in ambient temperatures above 75°F contact DODGE Engineering.
Contact DODGE Engineering for use with non-ventilated motors.

TORQUE METHOD OF SELECTION

- Step 1: **Determine Service Factor** Referring to the reducer service factor table, determine the appropriate service factor.
- Step 2: **Determine Equivalent Torque** Multiply the torque required to drive the load at the output of the reducer by the service factor obtained in Step 1. (If drive components, e.g, chain or belt drives are used between reducer and driven equipment be sure to account for them when calculating output torque at the reducer).
- Step 3: **Calculate Required Ratio** Divide the motor shaft rpm by the reducer output shaft rpm.

FEATURES/BENEFITS PAGE G4-2	SPECIFICATION PAGE G4-8	NOMENCLATURE PAGE G4-9	MODIFICATION PAGE G4-90
--------------------------------	----------------------------	---------------------------	----------------------------

SELECTION

TIGEAR-2 Selection Table

1.00 REDUCER SERVICE FACTOR

1750 RPM INPUT

Output Rpm	Ratio		Motor Horsepower												
			0.25	0.33	0.50	0.75	1.00	1.50	2.00	3.00	5.00	7.50	10.00	15.00	20.00
350	5	SIZE	13	13	13	13	13	15	17	20	23	30	30	35	40
		Torque	42	55	83	125	166	250	332	502	840	1279	1706	2563	3408
		OHL	650	650	650	650	650	710	1050	1380	1330	1330	1330	2120	2860
233	7.5	SIZE	13	13	13	13	13	17	17	23	26	30	35	40	47
		Torque	60	79	120	180	240	364	485	736	1231	1863	2495	3727	4969
		OHL	650	650	650	650	650	1190	1190	1520	1520	1540	2430	3280	5600
175	10	SIZE	13	13	13	13	15	17	20	23	30	35	35	47	
		Torque	80	105	160	240	321	480	644	972	1650	2498	3331	4973	
		OHL	650	650	650	650	710	1190	1560	1610	1720	2700	2700	5600	
117	15	SIZE	13	13	13	15	17	20	23	26	30	40	40		
		Torque	114	150	227	343	459	701	935	1417	2391	3599	4799		
		OHL	650	650	650	710	1190	1560	1610	1610	2300	4190	4190		
88	20	SIZE	13	13	13	17	17	23	23	30	35	40	47		
		Torque	143	189	286	438	583	898	1198	1845	3125	4665	6156		
		OHL	650	650	650	1190	1190	1610	1610	2300	2760	4300	5600		
70	25	SIZE	13	13	15	17	20	23	26	30	40	47			
		Torque	169	223	341	517	707	1074	1485	2245	3719	5489			
		OHL	650	650	710	1190	1560	1610	1610	2300	4300	5600			
58	30	SIZE	13	13	15	17	23	26	26	35	40				
		Torque	200	264	404	607	847	1312	1750	2662	4365				
		OHL	650	650	710	1190	1610	1610	1610	2760	4300				
44	40	SIZE	13	15	17	20	23	26	30	35	47				
		Torque	249	333	520	793	1071	1630	2224	3361	5350				
		OHL	650	710	1190	1560	1610	1610	2300	2760	5600				
35	50	SIZE	13	15	17	23	26	30	35	40					
		Torque	289	388	600	929	1262	1940	2637	3767					
		OHL	650	710	1190	1610	1610	2300	2760	4300					
29	60	SIZE	15	17	20	23	26	30	35	40					
		Torque	329	442	691	1037	1432	2179	2923	4234					
		OHL	710	1190	1560	1610	1610	2300	2760	4300					

Torque = Actual output torque in lb. - in

OHL - Maximum OHL capacity in lbs

SELECTION



TIGEAR-2 Selection Table

1.25 REDUCER SERVICE FACTOR

1750 RPM INPUT

Output Rpm	Ratio		Motor Horsepower												
			0.25	0.33	0.50	0.75	1.00	1.50	2.00	3.00	5.00	7.50	10.00	15.00	20.00
350	5	SIZE	13	13	13	13	13	17	17	23	26	30	35	40	47
		Torque	42	55	83	125	166	249	332	504	846	1279	1709	2556	3397
		OHL	520	520	520	520	520	840	840	1064	1064	1064	1696	2288	4080
233	7.5	SIZE	13	13	13	13	15	17	20	23	30	35	40	47	
		Torque	60	79	120	180	241	364	489	736	1242	1871	2485	3727	
		OHL	520	520	520	520	568	952	1248	1216	1232	1944	2624	4480	
175	10	SIZE	13	13	13	15	17	20	23	26	30	35	40	47	
		Torque	80	105	160	241	320	483	648	979	1650	2498	3315	4973	
		OHL	520	520	520	568	952	1248	1288	1288	1376	2160	2912	4480	
117	15	SIZE	13	13	13	17	17	23	23	30	35	40	47		
		Torque	114	150	227	345	459	701	935	1434	2418	3599	4796		
		OHL	520	520	520	952	952	1288	1288	1840	2208	3352	4480		
88	20	SIZE	13	13	15	17	20	23	26	30	40	47			
		Torque	143	189	292	438	596	898	1236	1845	3110	4617			
		OHL	520	520	568	952	1248	1288	1288	1840	3440	4480			
70	25	SIZE	13	13	17	20	23	26	30	35	40				
		Torque	169	223	345	530	716	1114	1497	2279	3719				
		OHL	520	520	952	1248	1288	1288	1840	2208	3440				
58	30	SIZE	13	150	17	20	23	26	30	35	47				
		Torque	200	267	404	625	847	1312	1766	2662	4308				
		OHL	520	568	952	1248	1288	1288	1840	2208	4480				
44	40	SIZE	13	150	20	23	26	30	35	40					
		Torque	249	333	529	803	1087	1668	2241	3253					
		OHL	520	568	1248	1288	1288	1840	2208	3440					
35	50	SIZE	150	17	20	23	26	35	35	47					
		Torque	294	396	617	929	1262	1978	2637	3705					
		OHL	568	952	1248	1288	1288	2208	2208	4480					
29	60	SIZE	17	17	23	26	30	35	40	47					
		Torque	335	442	692	1074	1453	2192	2822	4143					
		OHL	952	952	1288	1288	1840	2208	3440	4480					

Torque = Actual output torque in lb. - in

OHL - Maximum OHL capacity in lbs

FEATURES/BENEFITS PAGE G4-2	SPECIFICATION PAGE G4-8	NOMENCLATURE PAGE G4-9	MODIFICATION PAGE G4-90
--------------------------------	----------------------------	---------------------------	----------------------------

SELECTION

TIGEAR-2 Selection Table

1.50 REDUCER SERVICE FACTOR

1750 RPM INPUT

Output Rpm	Ratio		Motor Horsepower												
			0.25	0.33	0.50	0.75	1.00	1.50	2.00	3.00	5.00	7.50	10.00	15.00	20.00
350	5	SIZE	13	13	13	13	15	17	20	23	30	35	35	47	
		Torque	42	55	83	125	167	249	335	504	853	1281	1709	2548	
		OHL	433	433	433	433	473	700	700	887	887	1413	1413	3400	
233	7.5	SIZE	13	13	13	15	17	20	23	26	30	35	40	47	
		Torque	60	79	120	181	243	367	491	739	1242	1871	2485	3727	
		OHL	433	433	433	473	793	1040	1013	1013	1027	1620	2187	3733	
175	10	SIZE	13	13	13	15	17	20	23	26	35	40	47		
		Torque	80	105	160	241	320	483	648	979	1666	2486	3315		
		OHL	433	433	433	473	793	1040	1073	1073	1800	2427	3733		
117	15	SIZE	13	13	15	17	20	23	26	30	40	47			
		Torque	114	150	228	345	467	701	944	1434	2400	3597			
		OHL	433	433	473	793	1040	1073	1073	1533	2793	3733			
88	20	SIZE	13	13	17	20	23	26	30	35	40				
		Torque	143	189	292	447	599	927	1230	1875	3110				
		OHL	433	433	793	1040	1073	1073	1533	1840	2867				
70	25	SIZE	13	15	17	23	23	26	30	35	47				
		Torque	169	225	345	537	716	1114	1497	2279	3659				
		OHL	433	473	793	1073	1073	1073	1533	1840	3733				
58	30	SIZE	13	15	17	23	26	30	35	40	47				
		Torque	200	267	404	635	875	1324	1775	2619	4308				
		OHL	433	473	793	1073	1073	1533	1840	2867	3733				
44	40	SIZE	15	17	20	26	26	35	35	47					
		Torque	252	343	529	815	1087	1680	2241	3210					
		OHL	473	793	1040	1073	1073	1840	1840	3733					
35	50	SIZE	17	17	23	26	30	35	40	47					
		Torque	300	396	619	947	1293	1978	2511	3705					
		OHL	793	793	1073	1073	1533	1840	2867	3733					
29	60	SIZE	17	20	23	30	30	40	40						
		Torque	335	456	692	1090	1453	2117	2822						
		OHL	793	1040	1073	1533	1533	2867	2867						

Torque = Actual output torque in lb. - in

OHL - Maximum OHL capacity in lbs

SELECTION



TIGEAR-2 Selection Table

2.00 REDUCER SERVICE FACTOR

1750 RPM INPUT

Output Rpm	Ratio		Motor Horsepower												
			0.25	0.33	0.50	0.75	1.00	1.50	2.00	3.00	5.00	7.50	10.00	15.00	20.00
350	5	SIZE	13	13	13	15	17	20	23	26	30	35	40		
		Torque	42	55	83	125	166	251	336	508	853	1281	1704		
		OHL	325	325	325	355	525	690	665	665	665	1060	1430		
233	7.5	SIZE	13	13	13	17	17	23	23	30	35	40	47		
		Torque	60	79	120	182	243	368	491	745	1248	1863	2485		
		OHL	325	325	325	595	595	760	760	770	1215	1640	2800		
175	10	SIZE	13	13	15	17	20	23	26	30	35	47			
		Torque	80	105	160	240	322	486	653	990	1666	2487			
		OHL	325	325	355	595	780	805	805	860	1350	2800			
117	15	SIZE	13	15	17	20	23	26	30	35	40				
		Torque	114	151	230	350	468	708	956	1451	2400				
		OHL	325	355	595	780	805	805	1150	1380	2095				
88	20	SIZE	13	15	17	23	23	30	35	40	47				
		Torque	143	193	292	449	599	922	1250	1866	3078				
		OHL	325	355	595	805	805	1150	1380	2150	2800				
70	25	SIZE	15	17	20	23	26	30	35	40					
		Torque	170	227	354	537	743	1122	1519	2231					
		OHL	355	595	780	805	805	1150	1380	2150					
58	30	SIZE	150	17	23	26	26	35	35	47					
		Torque	202	267	424	656	875	1331	1775	2585					
		OHL	355	595	805	805	805	1380	1380	2800					
44	40	SIZE	17	20	23	26	30	35	40	47					
		Torque	260	349	536	815	1112	1680	2168	3210					
		OHL	595	780	805	805	1150	1380	2150	2800					
35	50	SIZE	17	23	26	30	35	40	47						
		Torque	300	409	631	970	1318	1884	2470						
		OHL	595	805	805	1150	1380	2150	2800						
29	60	SIZE	20	23	26	30	35	40	47						
		Torque	345	456	716	1090	1462	2117	2762						
		OHL	780	805	805	1150	1380	2150	2800						

Torque = Actual output torque in lb. - in

OHL - Maximum OHL capacity in lbs

FEATURES/BENEFITS PAGE G4-2	SPECIFICATION PAGE G4-8	NOMENCLATURE PAGE G4-9	MODIFICATION PAGE G4-90
--------------------------------	----------------------------	---------------------------	----------------------------

SELECTION/DIMENSIONS



TIGEAR-2 QUILL INPUT - SIZE 13

RATIO	OUTPUT RPM	RATING DATA			PART NUMBER	SHAFT
		1750 INPUT RPM			56C	POSITION
5	350	Mechanical Input Hp	1.32	13Q05L56	L	
		Thermal Input Hp	2.94	13Q05R56	R	
		Output Torque (lb in.)	219	13Q05LR56	LR	
		Mechanical Output Hp	1.22	13Q05H56	HOLLOW	
		Output OHL (lbs.)	650			
7.5	233	Mechanical Input Hp	1.04	13Q07L56	L	
		Thermal Input Hp	2.27	13Q07R56	R	
		Output Torque (lb in.)	251	13Q07LR56	LR	
		Mechanical Output Hp	0.94	13Q07H56	HOLLOW	
		Output OHL (lbs.)	650			
10	175	Mechanical Input Hp	0.85	13Q10L56	L	
		Thermal Input Hp	1.96	13Q10R56	R	
		Output Torque (lb in.)	270	13Q10LR56	LR	
		Mechanical Output Hp	0.75	13Q10H56	HOLLOW	
		Output OHL (lbs.)	650			
15	117	Mechanical Input Hp	0.64	13Q15L56	L	
		Thermal Input Hp	1.38	13Q15R56	R	
		Output Torque (lb in.)	293	13Q15LR56	LR	
		Mechanical Output Hp	0.54	13Q15H56	HOLLOW	
		Output OHL (lbs.)	650			
20	88	Mechanical Input Hp	0.53	13Q20L56	L	
		Thermal Input Hp	1.06	13Q20R56	R	
		Output Torque (lb in.)	304	13Q20LR56	LR	
		Mechanical Output Hp	0.42	13Q20H56	HOLLOW	
		Output OHL (lbs.)	650			
25	70	Mechanical Input Hp	0.46	13Q25L56	L	
		Thermal Input Hp	0.86	13Q25R56	R	
		Output Torque (lb in.)	311	13Q25LR56	LR	
		Mechanical Output Hp	0.35	13Q25H56	HOLLOW	
		Output OHL (lbs.)	650			
30	58	Mechanical Input Hp	0.39	13Q30L56	L	
		Thermal Input Hp	0.85	13Q30R56	R	
		Output Torque (lb in.)	314	13Q30LR56	LR	
		Mechanical Output Hp	0.29	13Q30H56	HOLLOW	
		Output OHL (lbs.)	650			
40	44	Mechanical Input Hp	0.32	13Q40L56	L	
		Thermal Input Hp	0.70	13Q40R56	R	
		Output Torque (lb in.)	319	13Q40LR56	LR	
		Mechanical Output Hp	0.22	13Q40H56	HOLLOW	
		Output OHL (lbs.)	650			
50	35	Mechanical Input Hp	0.27	13Q50L56	L	
		Thermal Input Hp	0.61	13Q50R56	R	
		Output Torque (lb in.)	313	13Q50LR56	LR	
		Mechanical Output Hp	0.17	13Q50H56	HOLLOW	
		Output OHL (lbs.)	650			
60	29	Mechanical Input Hp	0.23	13Q60L56	L	
		Thermal Input Hp	0.54	13Q60R56	R	
		Output Torque (lb in.)	298	13Q60LR56	LR	
		Mechanical Output Hp	0.14	13Q60H56	HOLLOW	
		Output OHL (lbs.)	650			

Note: Reducers are shipped without a mounting base. Order bolt-on base kit **13BASE** if required.

FEATURES/BENEFITS PAGE G4-2	SPECIFICATION PAGE G4-8	NOMENCLATURE PAGE G4-9	MODIFICATION/ACCESSORIES PAGE G4-90
--------------------------------	----------------------------	---------------------------	--

SELECTION/DIMENSIONS



TIGEAR-2 QUILL INPUT - SIZE 13

SOLID OUTPUT

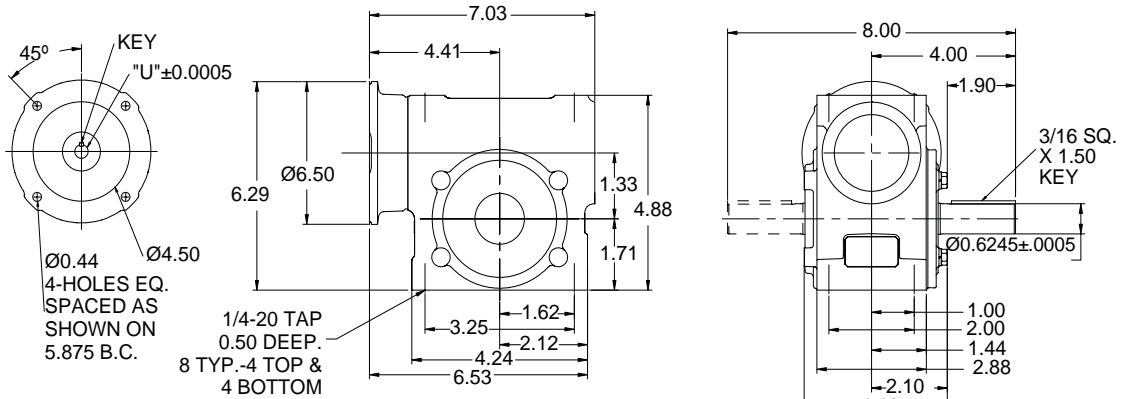

MOTOR FRAME	DIM "U"	KEY
48Y	$\text{Ø}0.626$	3/16 SQ. X 1.72 KEY
56C	$\text{Ø}0.626$	3/16 SQ. X 1.72 KEY

HOLLOW OUTPUT

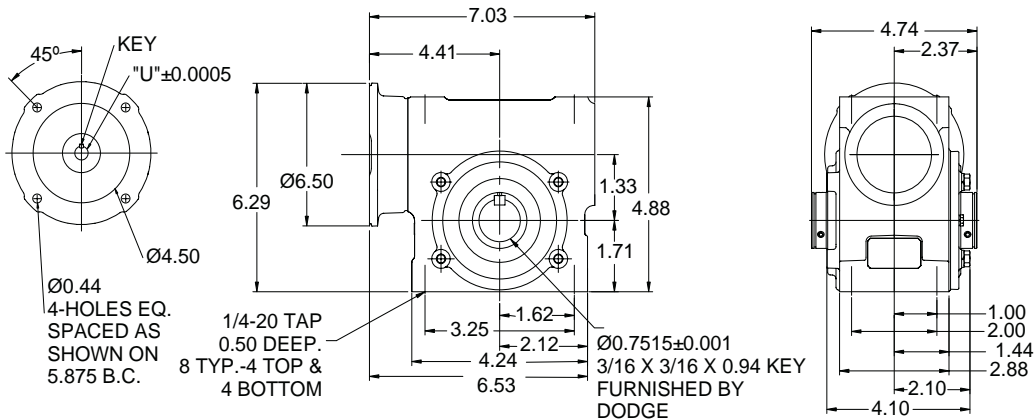

OUTPUT SHAFT CONFIGURATIONS

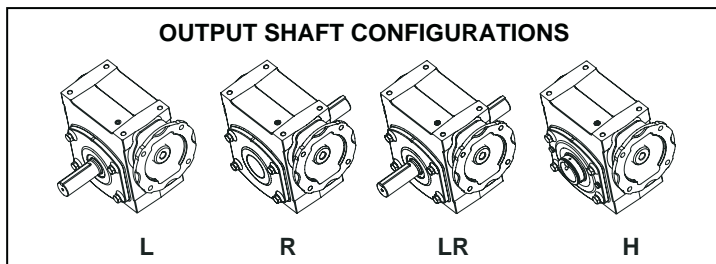

FEATURES/BENEFITS PAGE G4-2	SPECIFICATION PAGE G4-8	NOMENCLATURE PAGE G4-9	MODIFICATION/ACCESSORIES PAGE G4-90
--------------------------------	----------------------------	---------------------------	--



SELECTION/DIMENSIONS

TIGEAR-2 SEPARATE INPUT - SIZE 13

RATIO	OUTPUT RPM	RATING DATA 1750 INPUT RPM		SEPARATE REDUCER	SHAFT POSITION	OPTIONAL MOTOR ADAPTER KIT	
						56C	140TC
5	350	Mechanical Input Hp	1.32	13S05L 13S05R 13S05LR 13S05H	L R LR HOLLOW	1315MTR56	1315MTR14
		Thermal Input Hp	2.94				
		Output Torque (lb in.)	219				
		Mechanical Output Hp	1.22				
		Output OHL (lbs.)	650				
7.5	233	Mechanical Input Hp	1.04	13S07L 13S07R 13S07LR 13S07H	L R LR HOLLOW	1315MTR56	1315MTR14
		Thermal Input Hp	2.27				
		Output Torque (lb in.)	251				
		Mechanical Output Hp	0.94				
		Output OHL (lbs.)	650				
10	175	Mechanical Input Hp	0.85	13S10L 13S10R 13S10LR 13S10H	L R LR HOLLOW	1315MTR56	1315MTR14
		Thermal Input Hp	1.96				
		Output Torque (lb in.)	270				
		Mechanical Output Hp	0.75				
		Output OHL (lbs.)	650				
15	117	Mechanical Input Hp	0.64	13S15L 13S15R 13S15LR 13S15H	L R LR HOLLOW	1315MTR56	
		Thermal Input Hp	1.38				
		Output Torque (lb in.)	293				
		Mechanical Output Hp	0.54				
		Output OHL (lbs.)	650				
20	88	Mechanical Input Hp	0.53	13S20L 13S20R 13S20LR 13S20H	L R LR HOLLOW	1315MTR56	
		Thermal Input Hp	1.06				
		Output Torque (lb in.)	304				
		Mechanical Output Hp	0.42				
		Output OHL (lbs.)	650				
25	70	Mechanical Input Hp	0.46	13S25L 13S25R 13S25LR 13S25H	L R LR HOLLOW	1315MTR56	
		Thermal Input Hp	0.86				
		Output Torque (lb in.)	311				
		Mechanical Output Hp	0.35				
		Output OHL (lbs.)	650				
30	58	Mechanical Input Hp	0.39	13S30L 13S30R 13S30LR 13S30H	L R LR HOLLOW	1315MTR56	
		Thermal Input Hp	0.85				
		Output Torque (lb in.)	314				
		Mechanical Output Hp	0.29				
		Output OHL (lbs.)	650				
40	44	Mechanical Input Hp	0.32	13S40L 13S40R 13S40LR 13S40H	L R LR HOLLOW	1315MTR56	
		Thermal Input Hp	0.70				
		Output Torque (lb in.)	319				
		Mechanical Output Hp	0.22				
		Output OHL (lbs.)	650				
50	35	Mechanical Input Hp	0.27	13S50L 13S50R 13S50LR 13S50H	L R LR HOLLOW	1315MTR56	
		Thermal Input Hp	0.61				
		Output Torque (lb in.)	313				
		Mechanical Output Hp	0.17				
		Output OHL (lbs.)	650				
60	29	Mechanical Input Hp	0.23	13S60L 13S60R 13S60LR 13S60H	L R LR HOLLOW	1315MTR56	
		Thermal Input Hp	0.54				
		Output Torque (lb in.)	298				
		Mechanical Output Hp	0.14				
		Output OHL (lbs.)	650				
All Ratios		Input OHL (lbs)	120	One diameter from seal surface			

Note: TIGEAR-2 separate reducers cannot be used with the old Adaptable TIGEAR motor adapter kits.

SELECTION/DIMENSIONS



Gearing Reference Guide

TIGEAR-2 SEPARATE INPUT - SIZE 13

SOLID OUTPUT

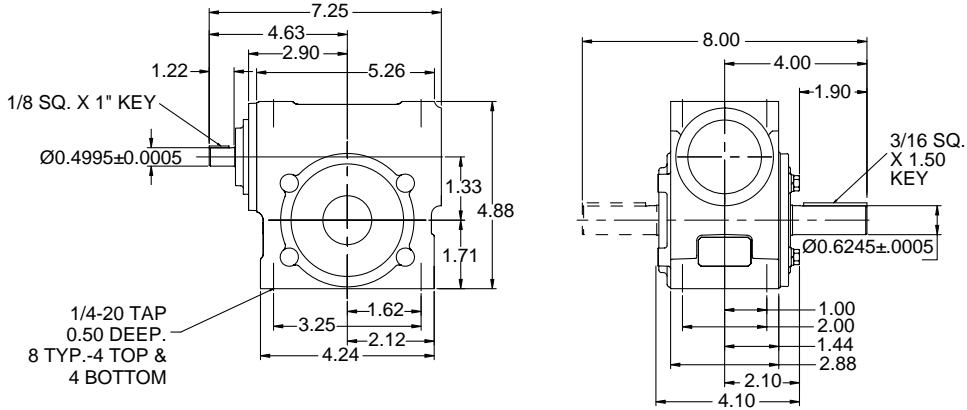

TORQUE-ARM II

HOLLOW OUTPUT

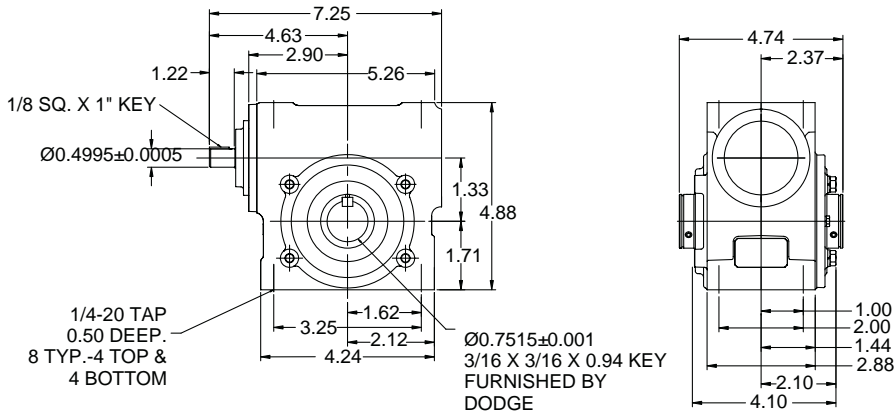

TORQUE-ARM

MAXIMUM Concentric Reducer

OUTPUT SHAFT CONFIGURATIONS

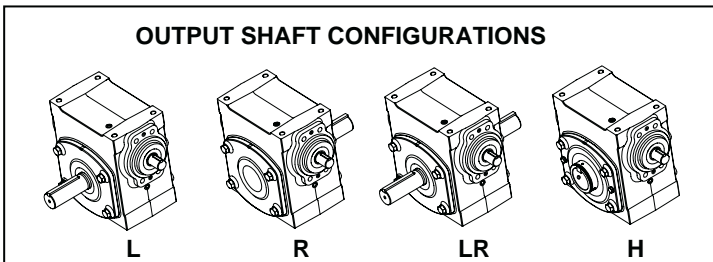

TIGEAR-2

FEATURES/BENEFITS PAGE G4-2	SPECIFICATION PAGE G4-8	NOMENCLATURE PAGE G4-9	MODIFICATION/ACCESSORIES PAGE G4-90
--------------------------------	----------------------------	---------------------------	--



SELECTION/DIMENSIONS

TIGEAR-2 COUPLED INPUT - ADAPTER ASSEMBLY - SIZE 13

Coupled input units include a Separate reducer and motor adapter kit assembled together. These assemblies are normally "made to order" with a 5 day standard lead time.

RATIO	OUTPUT RPM	RATING DATA 1750 INPUT RPM		PART NUMBER		SHAFT POSITION
				56C	140TC	
5	350	Mechanical Input Hp	1.32	13A05L56	13A05L14	L
		Thermal Input Hp	2.94	13A05R56	13A05RL14	R
		Output Torque (lb in.)	219	13A05LR56	13A05LR14	LR
		Mechanical Output Hp	1.22	13A05H56	13A05H14	HOLLOW
		Output OHL (lbs.)	650			
7.5	233	Mechanical Input Hp	1.04	13A07L56	13A07L14	L
		Thermal Input Hp	2.27	13A07R56	13A07RL14	R
		Output Torque (lb in.)	251	13A07LR56	13A07LR14	LR
		Mechanical Output Hp	0.94	13A07H56	13A07H14	HOLLOW
		Output OHL (lbs.)	650			
10	175	Mechanical Input Hp	0.85	13A10L56	13A10L14	L
		Thermal Input Hp	1.96	13A10R56	13A10RL14	R
		Output Torque (lb in.)	270	13A10LR56	13A10LR14	LR
		Mechanical Output Hp	0.75	13A10H56	13A10H14	HOLLOW
		Output OHL (lbs.)	650			
15	117	Mechanical Input Hp	0.64	13A15L56		L
		Thermal Input Hp	1.38	13A15R56		R
		Output Torque (lb in.)	293	13A15LR56		LR
		Mechanical Output Hp	0.54	13A15H56		HOLLOW
		Output OHL (lbs.)	650			
20	88	Mechanical Input Hp	0.53	13A20L56		L
		Thermal Input Hp	1.06	13A20R56		R
		Output Torque (lb in.)	304	13A20LR56		LR
		Mechanical Output Hp	0.42	13A20H56		HOLLOW
		Output OHL (lbs.)	650			
25	70	Mechanical Input Hp	0.46	13A25L56		L
		Thermal Input Hp	0.86	13A25R56		R
		Output Torque (lb in.)	311	13A25LR56		LR
		Mechanical Output Hp	0.35	13A25H56		HOLLOW
		Output OHL (lbs.)	650			
30	58	Mechanical Input Hp	0.39	13A30L56		L
		Thermal Input Hp	0.85	13A30R56		R
		Output Torque (lb in.)	314	13A30LR56		LR
		Mechanical Output Hp	0.29	13A30H56		HOLLOW
		Output OHL (lbs.)	650			
40	44	Mechanical Input Hp	0.32	13A40L56		L
		Thermal Input Hp	0.70	13A40R56		R
		Output Torque (lb in.)	319	13A40LR56		LR
		Mechanical Output Hp	0.22	13A40H56		HOLLOW
		Output OHL (lbs.)	650			
50	35	Mechanical Input Hp	0.27	13A50L56		L
		Thermal Input Hp	0.61	13A50R56		R
		Output Torque (lb in.)	313	13A50LR56		LR
		Mechanical Output Hp	0.17	13A50H56		HOLLOW
		Output OHL (lbs.)	650			
60	29	Mechanical Input Hp	0.23	13A60L56		L
		Thermal Input Hp	0.54	13A60R56		R
		Output Torque (lb in.)	298	13A60LR56		LR
		Mechanical Output Hp	0.14	13A60H56		HOLLOW
		Output OHL (lbs.)	650			

Note: Reducers are shipped without a mounting base. Order bolt-on base kit **13BASE** if required.

FEATURES/BENEFITS PAGE G4-2	SPECIFICATION PAGE G4-8	NOMENCLATURE PAGE G4-9	MODIFICATION/ACCESSORIES PAGE G4-90
--------------------------------	----------------------------	---------------------------	--

SELECTION/DIMENSIONS



TIGEAR-2 COUPLED INPUT - ADAPTER ASSEMBLY - SIZE 13

SOLID OUTPUT

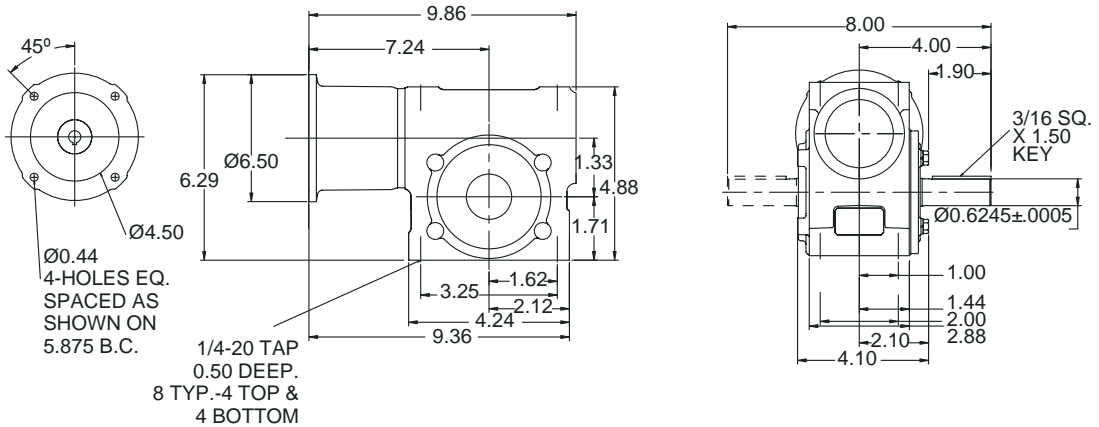

HOLLOW OUTPUT

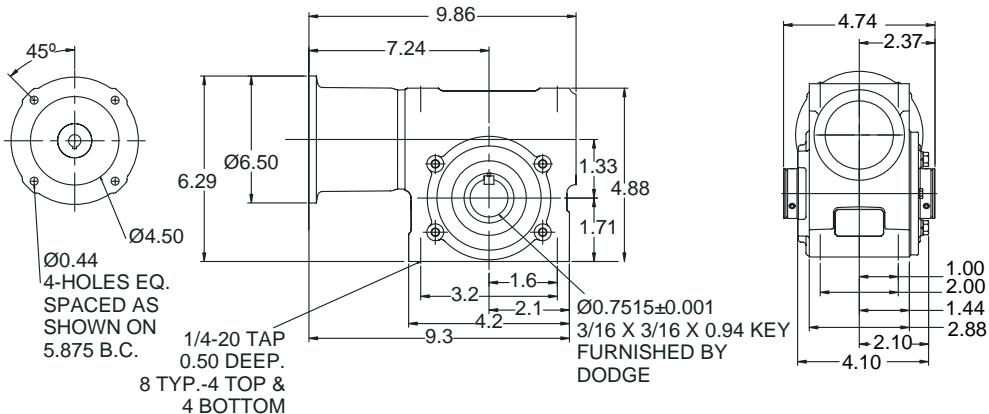

OUTPUT SHAFT CONFIGURATIONS

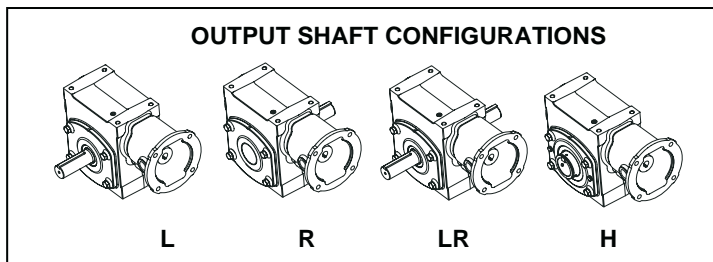

FEATURES/BENEFITS PAGE G4-2	SPECIFICATION PAGE G4-8	NOMENCLATURE PAGE G4-9	MODIFICATION/ACCESSORIES PAGE G4-90
--------------------------------	----------------------------	---------------------------	--

SELECTION/DIMENSIONS



TIGEAR-2 QUILL INPUT - SIZE 15

RATIO	OUTPUT RPM	RATING DATA			PART NUMBER	SHAFT POSITION
		1750 INPUT RPM			56C	
5	350	Mechanical Input Hp	1.75	15Q05L56	L	
		Thermal Input Hp	3.34	15Q05R56	R	
		Output Torque (lb in.)	293	15Q05LR56	LR	
		Mechanical Output Hp	1.63	15Q05H56	HOLLOW	
		Output OHL (lbs.)	710			
7.5	233	Mechanical Input Hp	1.40	15Q07L56	L	
		Thermal Input Hp	2.55	15Q07R56	R	
		Output Torque (lb in.)	337	15Q07LR56	LR	
		Mechanical Output Hp	1.26	15Q07H56	HOLLOW	
		Output OHL (lbs.)	710			
10	175	Mechanical Input Hp	1.13	15Q10L56	L	
		Thermal Input Hp	2.22	15Q10R56	R	
		Output Torque (lb in.)	361	15Q10LR56	LR	
		Mechanical Output Hp	1.00	15Q10H56	HOLLOW	
		Output OHL (lbs.)	710			
15	117	Mechanical Input Hp	0.86	15Q15L56	L	
		Thermal Input Hp	1.58	15Q15R56	R	
		Output Torque (lb in.)	392	15Q15LR56	LR	
		Mechanical Output Hp	0.73	15Q15H56	HOLLOW	
		Output OHL (lbs.)	710			
20	88	Mechanical Input Hp	0.70	15Q20L56	L	
		Thermal Input Hp	1.26	15Q20R56	R	
		Output Torque (lb in.)	407	15Q20LR56	LR	
		Mechanical Output Hp	0.56	15Q20H56	HOLLOW	
		Output OHL (lbs.)	710			
25	70	Mechanical Input Hp	0.60	15Q25L56	L	
		Thermal Input Hp	0.99	15Q25R56	R	
		Output Torque (lb in.)	410	15Q25LR56	LR	
		Mechanical Output Hp	0.46	15Q25H56	HOLLOW	
		Output OHL (lbs.)	710			
30	58	Mechanical Input Hp	0.51	15Q30L56	L	
		Thermal Input Hp	0.96	15Q30R56	R	
		Output Torque (lb in.)	413	15Q30LR56	LR	
		Mechanical Output Hp	0.38	15Q30H56	HOLLOW	
		Output OHL (lbs.)	710			
40	44	Mechanical Input Hp	0.41	15Q40L56	L	
		Thermal Input Hp	0.80	15Q40R56	R	
		Output Torque (lb in.)	417	15Q40LR56	LR	
		Mechanical Output Hp	0.29	15Q40H56	HOLLOW	
		Output OHL (lbs.)	710			
50	35	Mechanical Input Hp	0.34	15Q50L56	L	
		Thermal Input Hp	0.70	15Q50R56	R	
		Output Torque (lb in.)	402	15Q50LR56	LR	
		Mechanical Output Hp	0.22	15Q50H56	HOLLOW	
		Output OHL (lbs.)	710			
60	29	Mechanical Input Hp	0.29	15Q60L56	L	
		Thermal Input Hp	0.62	15Q60R56	R	
		Output Torque (lb in.)	381	15Q60LR56	LR	
		Mechanical Output Hp	0.18	15Q60H56	HOLLOW	
		Output OHL (lbs.)	710			

Note: Reducers are shipped without a mounting base. Order bolt-on base kit **15BASE** if required.

FEATURES/BENEFITS PAGE G4-2	SPECIFICATION PAGE G4-8	NOMENCLATURE PAGE G4-9	MODIFICATION/ACCESSORIES PAGE G4-90
--------------------------------	----------------------------	---------------------------	--

SELECTION/DIMENSIONS



TIGEAR-2 QUILL INPUT - SIZE 15

SOLID OUTPUT

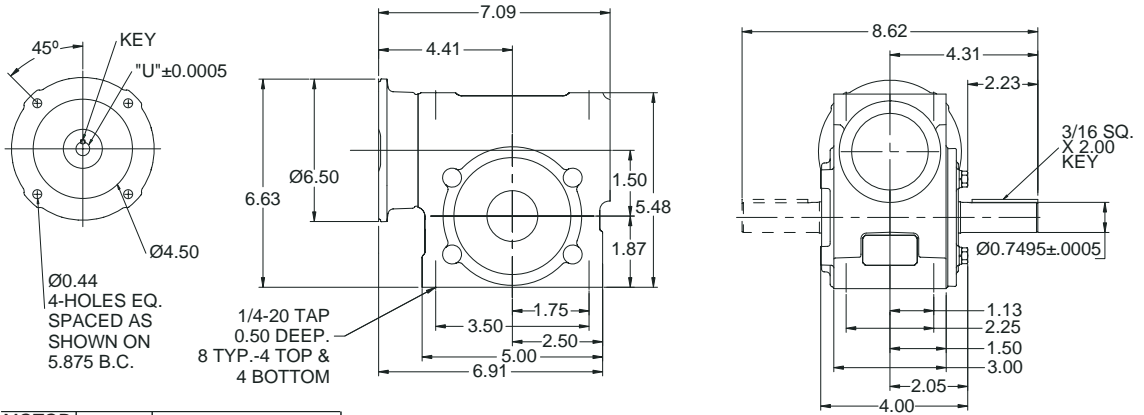

MOTOR FRAME	"U"	KEY
48Y 56C	$\varnothing 0.626$	3/16 SQ. X 1.72 KEY

HOLLOW OUTPUT

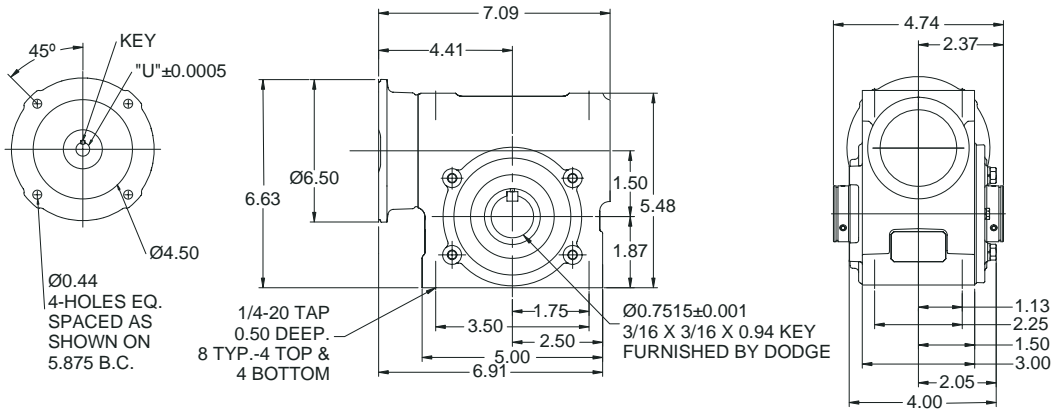

OUTPUT SHAFT CONFIGURATIONS

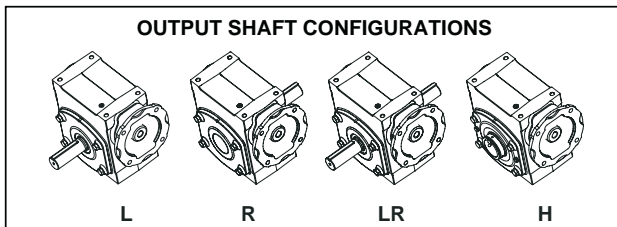

FEATURES/BENEFITS PAGE G4-2	SPECIFICATION PAGE G4-8	NOMENCLATURE PAGE G4-9	MODIFICATION/ACCESSORIES PAGE G4-90
--------------------------------	----------------------------	---------------------------	--

SELECTION/DIMENSIONS



TIGEAR-2 SEPARATE INPUT - SIZE 15

RATIO	OUTPUT RPM	RATING DATA 1750 INPUT RPM		SEPARATE REDUCER	SHAFT POSITION	OPTIONAL MOTOR ADAPTER KIT	
						56C	140TC
5	350	Mechanical Input Hp	1.75	15S05L	L	1315MTR56	1315MTR14
		Thermal Input Hp	3.34	15S05R	R		
		Output Torque (lb in.)	293	15S05LR	LR		
		Mechanical Output Hp	1.63	15S05H	HOLLOW		
		Output OHL (lbs.)	710				
7.5	233	Mechanical Input Hp	1.40	15S07L	L	1315MTR56	1315MTR14
		Thermal Input Hp	2.55	15S07R	R		
		Output Torque (lb in.)	337	15S07LR	LR		
		Mechanical Output Hp	1.26	15S07H	HOLLOW		
		Output OHL (lbs.)	710				
10	175	Mechanical Input Hp	1.13	15S10L	L	1315MTR56	1315MTR14
		Thermal Input Hp	2.22	15S10R	R		
		Output Torque (lb in.)	361	15S10LR	LR		
		Mechanical Output Hp	1.00	15S10H	HOLLOW		
		Output OHL (lbs.)	710				
15	117	Mechanical Input Hp	0.86	15S15L	L	1315MTR56	
		Thermal Input Hp	1.58	15S15R	R		
		Output Torque (lb in.)	392	15S15LR	LR		
		Mechanical Output Hp	0.73	15S15H	HOLLOW		
		Output OHL (lbs.)	710				
20	88	Mechanical Input Hp	0.70	15S20L	L	1315MTR56	
		Thermal Input Hp	1.26	15S20R	R		
		Output Torque (lb in.)	407	15S20LR	LR		
		Mechanical Output Hp	0.56	15S20H	HOLLOW		
		Output OHL (lbs.)	710				
25	70	Mechanical Input Hp	0.60	15S25L	L	1315MTR56	
		Thermal Input Hp	0.99	15S25R	R		
		Output Torque (lb in.)	410	15S25LR	LR		
		Mechanical Output Hp	0.46	15S25H	HOLLOW		
		Output OHL (lbs.)	710				
30	58	Mechanical Input Hp	0.51	15S30L	L	1315MTR56	
		Thermal Input Hp	0.96	15S30R	R		
		Output Torque (lb in.)	413	15S30LR	LR		
		Mechanical Output Hp	0.38	15S30H	HOLLOW		
		Output OHL (lbs.)	710				
40	44	Mechanical Input Hp	0.41	15S40L	L	1315MTR56	
		Thermal Input Hp	0.80	15S40R	R		
		Output Torque (lb in.)	417	15S40LR	LR		
		Mechanical Output Hp	0.29	15S40H	HOLLOW		
		Output OHL (lbs.)	710				
50	35	Mechanical Input Hp	0.34	15S50L	L	1315MTR56	
		Thermal Input Hp	0.70	15S50R	R		
		Output Torque (lb in.)	402	15S50LR	LR		
		Mechanical Output Hp	0.22	15S50H	HOLLOW		
		Output OHL (lbs.)	710				
60	29	Mechanical Input Hp	0.29	15S60L	L	1315MTR56	
		Thermal Input Hp	0.62	15S60R	R		
		Output Torque (lb in.)	381	15S60LR	LR		
		Mechanical Output Hp	0.18	15S60H	HOLLOW		
		Output OHL (lbs.)	710				
All Ratios		Input OHL (lbs.)	140	One diameter from seal surface			

Note: TIGEAR-2 separate reducers cannot be used with the old Adaptable TIGEAR motor adapter kits.

SELECTION/DIMENSIONS



TIGEAR-2 SEPARATE INPUT - SIZE 15

SOLID OUTPUT

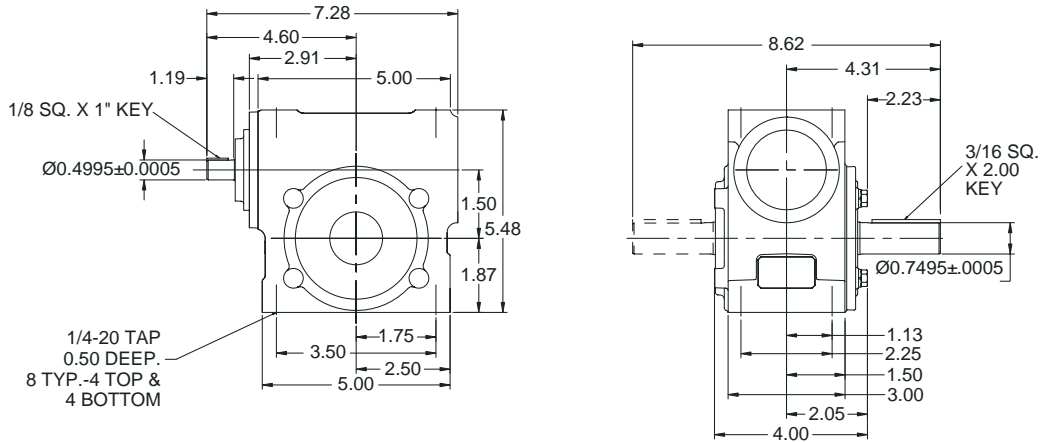

HOLLOW OUTPUT

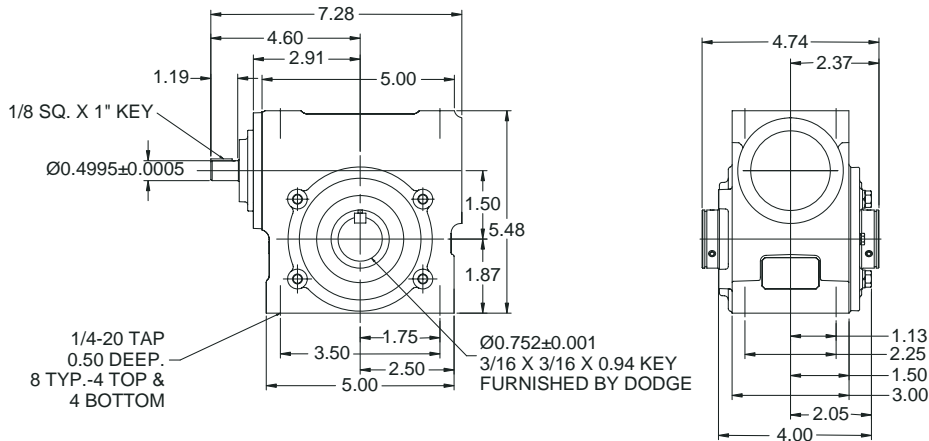

OUTPUT SHAFT CONFIGURATIONS

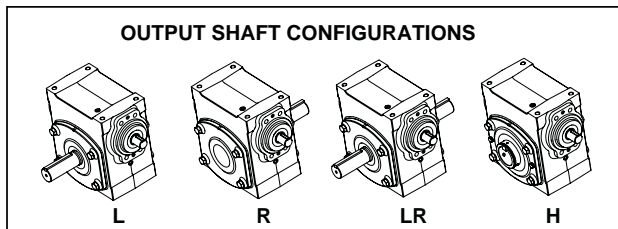



SELECTION/DIMENSIONS

TIGEAR-2 COUPLED INPUT - ADAPTER ASSEMBLY - SIZE 15

Coupled input units include a Separate reducer and motor adapter kit assembled together.

These assemblies are normally "made to order" with a 5 day standard lead time.

RATIO	OUTPUT RPM	RATING DATA 1750 INPUT RPM		PART NUMBER		SHAFT POSITION
				56C	140TC	
5	350	Mechanical Input Hp	1.75	15A05L56	15A05L14	L
		Thermal Input Hp	3.34	15A05R56	15A05R14	R
		Output Torque (lb in.)	293	15A05LR56	15A05LR14	LR
		Mechanical Output Hp	1.63	15A05H56	15A05H14	HOLLOW
		Output OHL (lbs.)	710			
7.5	233	Mechanical Input Hp	1.40	15A07L56	15A07L14	L
		Thermal Input Hp	2.55	15A07R56	15A07R14	R
		Output Torque (lb in.)	337	15A07LR56	15A07LR14	LR
		Mechanical Output Hp	1.26	15A07H56	15A07H14	HOLLOW
		Output OHL (lbs.)	710			
10	175	Mechanical Input Hp	1.13	15A10L56	15A10L14	L
		Thermal Input Hp	2.22	15A10R56	15A10R14	R
		Output Torque (lb in.)	361	15A10LR56	15A10LR14	LR
		Mechanical Output Hp	1.00	15A10H56	15A10H14	HOLLOW
		Output OHL (lbs.)	710			
15	117	Mechanical Input Hp	0.86	15A15L56		L
		Thermal Input Hp	1.58	15A15R56		R
		Output Torque (lb in.)	392	15A15LR56		LR
		Mechanical Output Hp	0.73	15A15H56		HOLLOW
		Output OHL (lbs.)	710			
20	88	Mechanical Input Hp	0.70	15A20L56		L
		Thermal Input Hp	1.26	15A20R56		R
		Output Torque (lb in.)	407	15A20LR56		LR
		Mechanical Output Hp	0.56	15A20H56		HOLLOW
		Output OHL (lbs.)	710			
25	70	Mechanical Input Hp	0.60	15A25L56		L
		Thermal Input Hp	0.99	15A25R56		R
		Output Torque (lb in.)	410	15A25LR56		LR
		Mechanical Output Hp	0.46	15A25H56		HOLLOW
		Output OHL (lbs.)	710			
30	58	Mechanical Input Hp	0.51	15A30L56		L
		Thermal Input Hp	0.96	15A30R56		R
		Output Torque (lb in.)	413	15A30LR56		LR
		Mechanical Output Hp	0.38	15A30H56		HOLLOW
		Output OHL (lbs.)	710			
40	44	Mechanical Input Hp	0.41	15A40L56		L
		Thermal Input Hp	0.80	15A40R56		R
		Output Torque (lb in.)	417	15A40LR56		LR
		Mechanical Output Hp	0.29	15A40H56		HOLLOW
		Output OHL (lbs.)	710			
50	35	Mechanical Input Hp	0.34	15A50L56		L
		Thermal Input Hp	0.70	15A50R56		R
		Output Torque (lb in.)	402	15A50LR56		LR
		Mechanical Output Hp	0.22	15A50H56		HOLLOW
		Output OHL (lbs.)	710			
60	29	Mechanical Input Hp	0.29	15A60L56		L
		Thermal Input Hp	0.62	15A60R56		R
		Output Torque (lb in.)	381	15A60LR56		LR
		Mechanical Output Hp	0.18	15A60H56		HOLLOW
		Output OHL (lbs.)	710			

Note: Reducers are shipped without a mounting base. Order bolt-on base kit **15BASE** if required.

FEATURES/BENEFITS PAGE G4-2	SPECIFICATION PAGE G4-8	NOMENCLATURE PAGE G4-9	MODIFICATION/ACCESSORIES PAGE G4-90
--------------------------------	----------------------------	---------------------------	--

SELECTION/DIMENSIONS



TIGEAR-2 COUPLED INPUT - ADAPTER ASSEMBLY - SIZE 15

SOLID OUTPUT

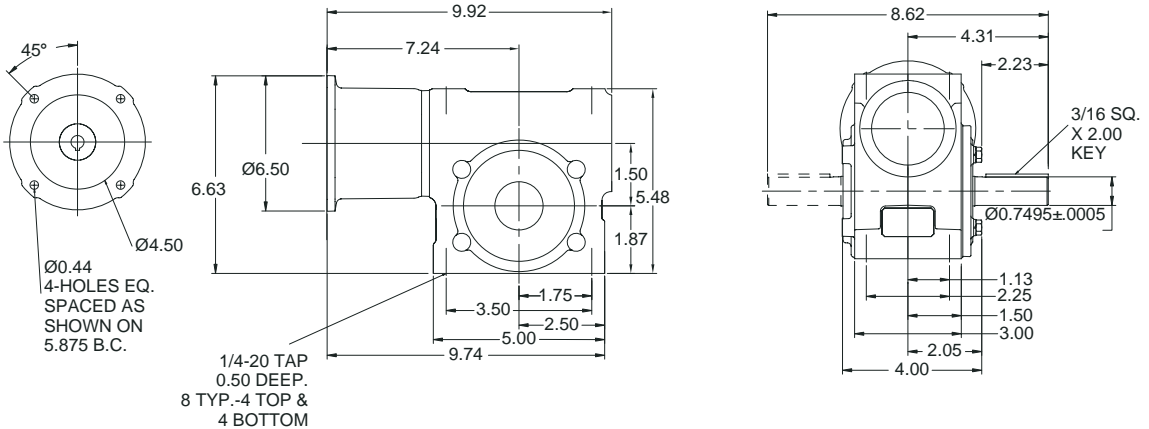

HOLLOW OUTPUT

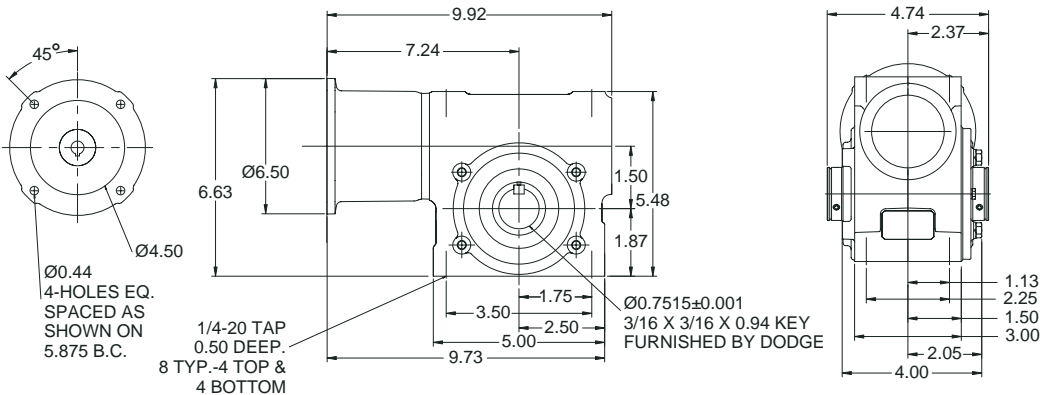

OUTPUT SHAFT CONFIGURATIONS

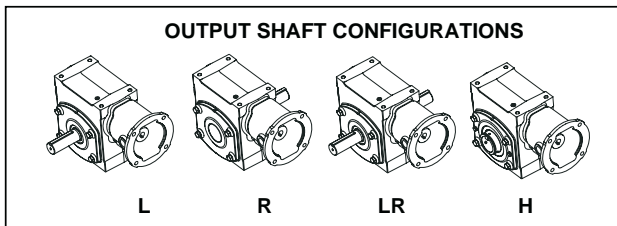

FEATURES/BENEFITS PAGE G4-2	SPECIFICATION PAGE G4-8	NOMENCLATURE PAGE G4-9	MODIFICATION/ACCESSORIES PAGE G4-90
--------------------------------	----------------------------	---------------------------	--

SELECTION/DIMENSIONS

DODGE®



TIGEAR-2 QUILL INPUT - SIZE 17

RATIO	OUTPUT RPM	RATING DATA 1750 INPUT RPM		PART NUMBER		SHAFT POSITION
				56C	140TC	
5	350	Mechanical Input Hp	2.59	17Q05L56	17Q05L14	L
		Thermal Input Hp	3.97	17Q05R56	17Q05R14	R
		Output Torque (lb in.)	430	17Q05LR56	17Q05LR14	LR
		Mechanical Output Hp	2.39	17Q05H56	17Q05H14	HOLLOW
		Output OHL (lbs.)	1050			
7.5	233	Mechanical Input Hp	2.06	17Q07L56	17Q07L14	L
		Thermal Input Hp	3.42	17Q07R56	17Q07R14	R
		Output Torque (lb in.)	500	17Q07LR56	17Q07LR14	LR
		Mechanical Output Hp	1.88	17Q07H56	17Q07H14	HOLLOW
		Output OHL (lbs.)	1190			
10	175	Mechanical Input Hp	1.67	17Q10L56	17Q10L14	L
		Thermal Input Hp	2.76	17Q10R56	17Q10R14	R
		Output Torque (lb in.)	534	17Q10LR56	17Q10LR14	LR
		Mechanical Output Hp	1.48	17Q10H56	17Q10H14	HOLLOW
		Output OHL (lbs.)	1190			
15	117	Mechanical Input Hp	1.27	17Q15L56	17Q15L14	L
		Thermal Input Hp	2.01	17Q15R56	17Q15R14	R
		Output Torque (lb in.)	583	17Q15LR56	17Q15LR14	LR
		Mechanical Output Hp	1.08	17Q15H56	17Q15H14	HOLLOW
		Output OHL (lbs.)	1190			
20	88	Mechanical Input Hp	1.03	17Q20L56	17Q20L14	L
		Thermal Input Hp	1.58	17Q20R56	17Q20R14	R
		Output Torque (lb in.)	602	17Q20LR56	17Q20LR14	LR
		Mechanical Output Hp	0.84	17Q20H56	17Q20H14	HOLLOW
		Output OHL (lbs.)	1190			
25	70	Mechanical Input Hp	0.88	17Q25L56		L
		Thermal Input Hp	1.28	17Q25R56		R
		Output Torque (lb in.)	609	17Q25LR56		LR
		Mechanical Output Hp	0.68	17Q25H56		HOLLOW
		Output OHL (lbs.)	1190			
30	58	Mechanical Input Hp	0.76	17Q30L56		L
		Thermal Input Hp	1.20	17Q30R56		R
		Output Torque (lb in.)	615	17Q30LR56		LR
		Mechanical Output Hp	0.57	17Q30H56		HOLLOW
		Output OHL (lbs.)	1190			
40	44	Mechanical Input Hp	0.60	17Q40L56		L
		Thermal Input Hp	1.09	17Q40R56		R
		Output Torque (lb in.)	627	17Q40LR56		LR
		Mechanical Output Hp	0.43	17Q40H56		HOLLOW
		Output OHL (lbs.)	1190			
50	35	Mechanical Input Hp	0.51	17Q50L56		L
		Thermal Input Hp	0.90	17Q50R56		R
		Output Torque (lb in.)	608	17Q50LR56		LR
		Mechanical Output Hp	0.34	17Q50H56		HOLLOW
		Output OHL (lbs.)	1190			
60	29	Mechanical Input Hp	0.43	17Q60L56		L
		Thermal Input Hp	0.80	17Q60R56		R
		Output Torque (lb in.)	576	17Q60LR56		LR
		Mechanical Output Hp	0.27	17Q60H56		HOLLOW
		Output OHL (lbs.)	1190			

Note: Reducers are shipped without a mounting base. Order bolt-on base kit **17BASE** if required.

FEATURES/BENEFITS PAGE G4-2	SPECIFICATION PAGE G4-8	NOMENCLATURE PAGE G4-9	MODIFICATION/ACCESSORIES PAGE G4-90
--------------------------------	----------------------------	---------------------------	--

SELECTION/DIMENSIONS



TIGEAR-2 QUILL INPUT - SIZE 17

SOLID OUTPUT

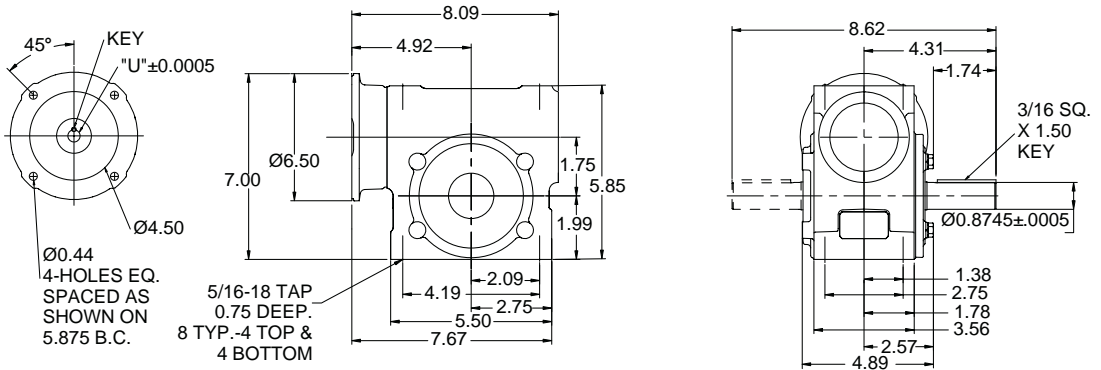

HOLLOW OUTPUT

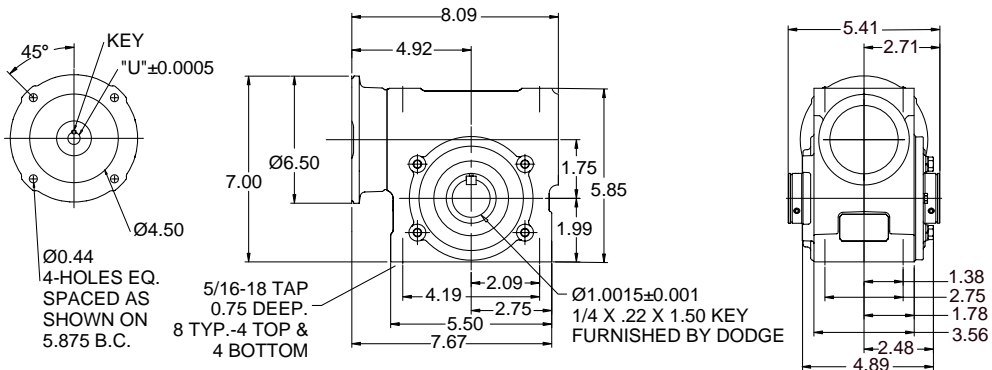

MOTOR FRAME	"U"	KEY
48Y 56C	.626	3/16 SQ. x 1.50 KEY
140TC 160ATC	.876	3/16 SQ x 1.50 KEY

OUTPUT SHAFT CONFIGURATIONS

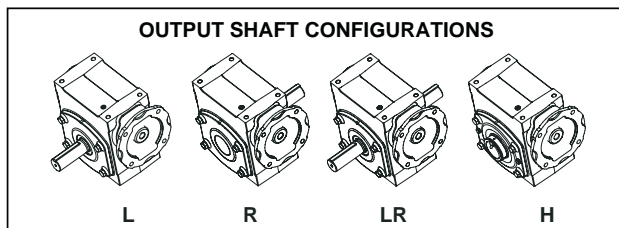

FEATURES/BENEFITS PAGE G4-2	SPECIFICATION PAGE G4-8	NOMENCLATURE PAGE G4-9	MODIFICATION/ACCESSORIES PAGE G4-90
--------------------------------	----------------------------	---------------------------	--



SELECTION/DIMENSIONS

TIGEAR-2 SEPARATE INPUT - SIZE 17

RATIO	OUTPUT RPM	RATING DATA		SEPARATE REDUCER	SHAFT POSITION	OPTIONAL MOTOR ADAPTER KIT	
		1750 INPUT RPM				56C	140TC
5	350	Mechanical Input Hp	2.59	17S05L	L	1720MTR56	1720MTR14
		Thermal Input Hp	3.97	17S05R	R		
		Output Torque (lb in.)	430	17S05LR	LR		
		Mechanical Output Hp	2.39	17S05H	HOLLOW		
		Output OHL (lbs.)	1050				
7.5	233	Mechanical Input Hp	2.06	17S07L	L	1720MTR56	1720MTR14
		Thermal Input Hp	3.42	17S07R	R		
		Output Torque (lb in.)	500	17S07LR	LR		
		Mechanical Output Hp	1.88	17S07H	HOLLOW		
		Output OHL (lbs.)	1190				
10	175	Mechanical Input Hp	1.67	17S10L	L	1720MTR56	1720MTR14
		Thermal Input Hp	2.76	17S10R	R		
		Output Torque (lb in.)	534	17S10LR	LR		
		Mechanical Output Hp	1.48	17S10H	HOLLOW		
		Output OHL (lbs.)	1190				
15	117	Mechanical Input Hp	1.27	17S15L	L	1720MTR56	1720MTR14
		Thermal Input Hp	2.01	17S15R	R		
		Output Torque (lb in.)	583	17S15LR	LR		
		Mechanical Output Hp	1.08	17S15H	HOLLOW		
		Output OHL (lbs.)	1190				
20	88	Mechanical Input Hp	1.03	17S20L	L	1720MTR56	1720MTR14
		Thermal Input Hp	1.58	17S20R	R		
		Output Torque (lb in.)	602	17S20LR	LR		
		Mechanical Output Hp	0.84	17S20H	HOLLOW		
		Output OHL (lbs.)	1190				
25	70	Mechanical Input Hp	0.88	17S25L	L	1720MTR56	
		Thermal Input Hp	1.28	17S25R	R		
		Output Torque (lb in.)	609	17S25LR	LR		
		Mechanical Output Hp	0.68	17S25H	HOLLOW		
		Output OHL (lbs.)	1190				
30	58	Mechanical Input Hp	0.76	17S30L	L	1720MTR56	
		Thermal Input Hp	1.20	17S30R	R		
		Output Torque (lb in.)	615	17S30LR	LR		
		Mechanical Output Hp	0.57	17S30H	HOLLOW		
		Output OHL (lbs.)	1190				
40	44	Mechanical Input Hp	0.60	17S40L	L	1720MTR56	
		Thermal Input Hp	1.09	17S40R	R		
		Output Torque (lb in.)	627	17S40LR	LR		
		Mechanical Output Hp	0.43	17S40H	HOLLOW		
		Output OHL (lbs.)	1190				
50	35	Mechanical Input Hp	0.51	17S50L	L	1720MTR56	
		Thermal Input Hp	0.90	17S50R	R		
		Output Torque (lb in.)	608	17S50LR	LR		
		Mechanical Output Hp	0.34	17S50H	HOLLOW		
		Output OHL (lbs.)	1190				
60	29	Mechanical Input Hp	0.43	17S60L	L	1720MTR56	
		Thermal Input Hp	0.80	17S60R	R		
		Output Torque (lb in.)	576	17S60LR	LR		
		Mechanical Output Hp	0.27	17S60H	HOLLOW		
		Output OHL (lbs.)	1190				
All Ratios		Input OHL (lbs)	140	One diameter from seal surface			

Note: TIGEAR-2 separate reducers cannot be used with the old Adaptable TIGEAR motor adapter kits.

SELECTION/DIMENSIONS



TIGEAR-2 SEPARATE INPUT - SIZE 17

SOLID OUTPUT

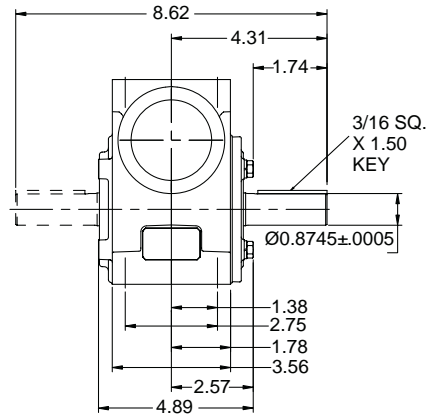
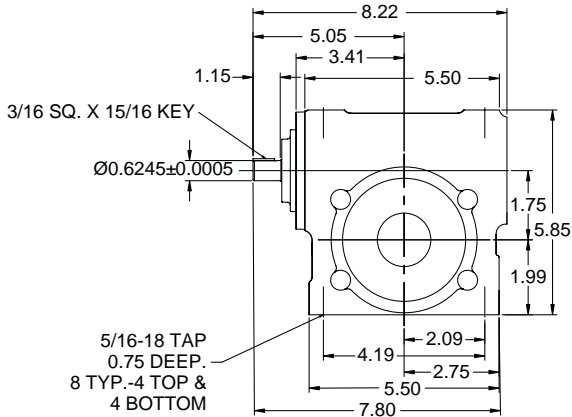

HOLLOW OUTPUT

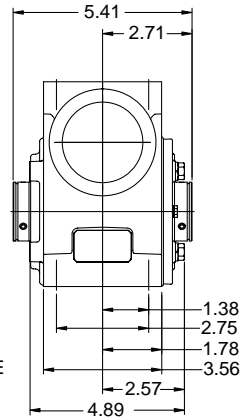
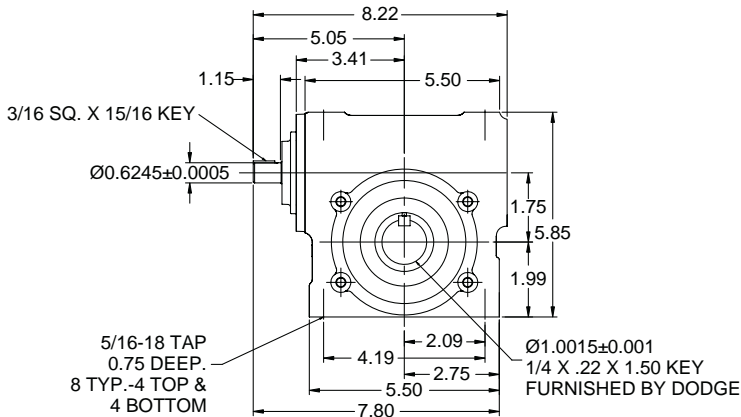

OUTPUT SHAFT CONFIGURATIONS

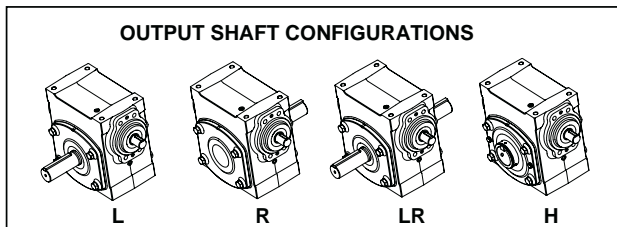

FEATURES/BENEFITS
PAGE G4-2

SPECIFICATION
PAGE G4-8

NOMENCLATURE
PAGE G4-9

MODIFICATION/ACCESSORIES
PAGE G4-90



SELECTION/DIMENSIONS

TIGEAR-2 COUPLED INPUT - ADAPTER ASSEMBLY - SIZE 17

Coupled input units include a Separate reducer and motor adapter kit assembled together.

These assemblies are normally "made to order" with a 5 day standard lead time.

RATIO	OUTPUT RPM	RATING DATA 1750 INPUT RPM		PART NUMBER		SHAFT POSITION
				56C	140TC	
5	350	Mechanical Input Hp	2.59	17A05L56	17A05L14	L
		Thermal Input Hp	3.97	17A05R56	17A05R14	R
		Output Torque (lb in.)	430	17A05LR56	17A05LR14	LR
		Mechanical Output Hp	2.39	17A05H56	17A05H14	HOLLOW
		Output OHL (lbs.)	1050			
7.5	233	Mechanical Input Hp	2.06	17A07L56	17A07L14	L
		Thermal Input Hp	3.42	17A07R56	17A07R14	R
		Output Torque (lb in.)	500	17A07LR56	17A07LR14	LR
		Mechanical Output Hp	1.88	17A07H56	17A07H14	HOLLOW
		Output OHL (lbs.)	1190			
10	175	Mechanical Input Hp	1.67	17A10L56	17A10L14	L
		Thermal Input Hp	2.76	17A10R56	17A10R14	R
		Output Torque (lb in.)	534	17A10LR56	17A10LR14	LR
		Mechanical Output Hp	1.48	17A10H56	17A10H14	HOLLOW
		Output OHL (lbs.)	1190			
15	117	Mechanical Input Hp	1.27	17A15L56	17A15L14	L
		Thermal Input Hp	2.01	17A15R56	17A15R14	R
		Output Torque (lb in.)	583	17A15LR56	17A15LR14	LR
		Mechanical Output Hp	1.08	17A15H56	17A15H14	HOLLOW
		Output OHL (lbs.)	1190			
20	88	Mechanical Input Hp	1.03	17A20L56	17A20L14	L
		Thermal Input Hp	1.58	17A20R56	17A20R14	R
		Output Torque (lb in.)	602	17A20LR56	17A20LR14	LR
		Mechanical Output Hp	0.84	17A20H56	17A20H14	HOLLOW
		Output OHL (lbs.)	1190			
25	70	Mechanical Input Hp	0.88	17A25L56		L
		Thermal Input Hp	1.28	17A25R56		R
		Output Torque (lb in.)	609	17A25LR56		LR
		Mechanical Output Hp	0.68	17A25H56		HOLLOW
		Output OHL (lbs.)	1190			
30	58	Mechanical Input Hp	0.76	17A30L56		L
		Thermal Input Hp	1.20	17A30R56		R
		Output Torque (lb in.)	615	17A30LR56		LR
		Mechanical Output Hp	0.57	17A30H56		HOLLOW
		Output OHL (lbs.)	1190			
40	44	Mechanical Input Hp	0.60	17A40L56		L
		Thermal Input Hp	1.09	17A40R56		R
		Output Torque (lb in.)	627	17A40LR56		LR
		Mechanical Output Hp	0.43	17A40H56		HOLLOW
		Output OHL (lbs.)	1190			
50	35	Mechanical Input Hp	0.51	17A50L56		L
		Thermal Input Hp	0.90	17A50R56		R
		Output Torque (lb in.)	608	17A50LR56		LR
		Mechanical Output Hp	0.34	17A50H56		HOLLOW
		Output OHL (lbs.)	1190			
60	29	Mechanical Input Hp	0.43	17A60L56		L
		Thermal Input Hp	0.80	17A60R56		R
		Output Torque (lb in.)	576	17A60LR56		LR
		Mechanical Output Hp	0.27	17A60H56		HOLLOW
		Output OHL (lbs.)	1190			

Note: Reducers are shipped without a mounting base. Order bolt-on base kit **17BASE** if required.

FEATURES/BENEFITS PAGE G4-2	SPECIFICATION PAGE G4-8	NOMENCLATURE PAGE G4-9	MODIFICATION/ACCESSORIES PAGE G4-90
--------------------------------	----------------------------	---------------------------	--

SELECTION/DIMENSIONS



TIGEAR-2 COUPLED INPUT - ADAPTER ASSEMBLY - SIZE 17

SOLID OUTPUT

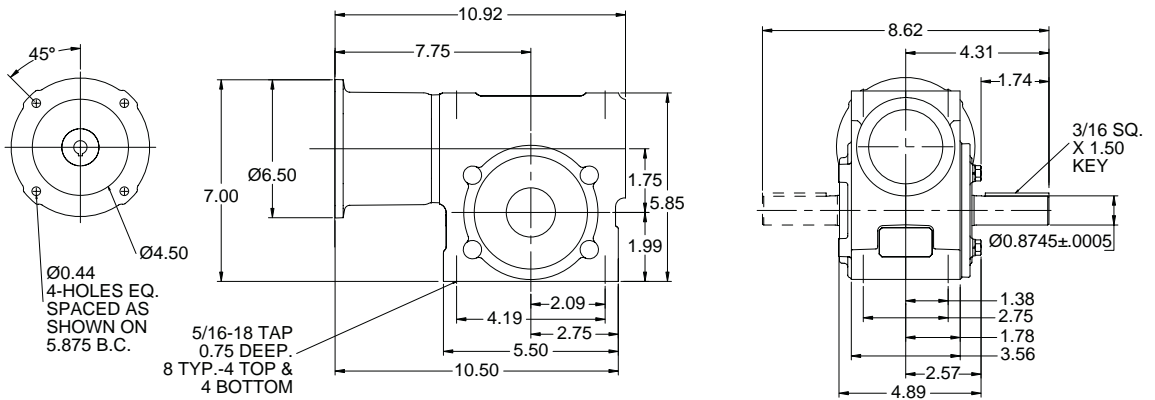

HOLLOW OUTPUT

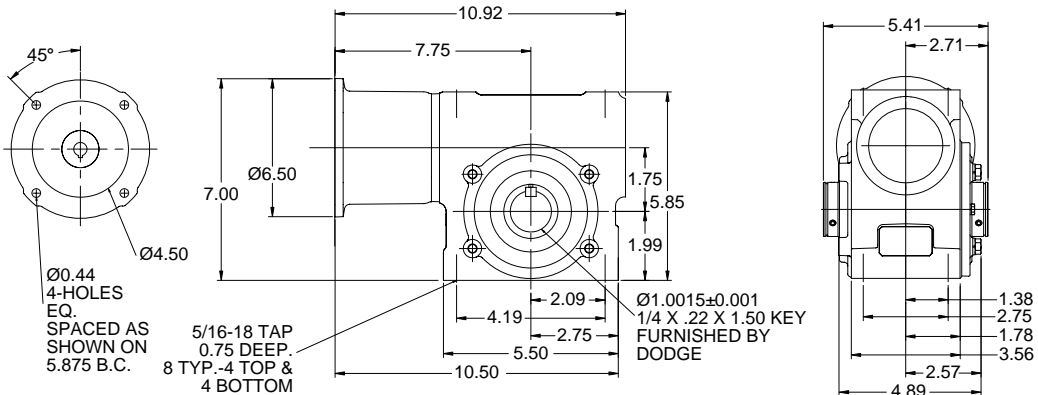

OUTPUT SHAFT CONFIGURATIONS

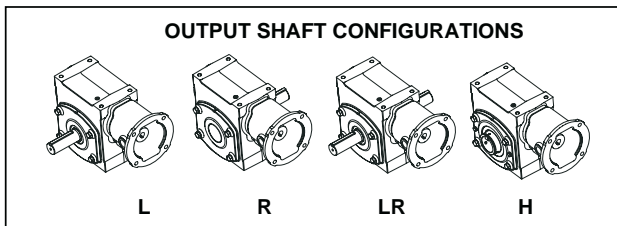

FEATURES/BENEFITS PAGE G4-2	SPECIFICATION PAGE G4-8	NOMENCLATURE PAGE G4-9	MODIFICATION/ACCESSORIES PAGE G4-90
--------------------------------	----------------------------	---------------------------	--

SELECTION/DIMENSIONS

TIGEAR-2 QUILL INPUT - SIZE 176

SIZE 17 WITH 1" EXTENDED LENGTH OUTPUT SHAFT

MOTOR FRAME	SHAFT POSITION	RATIO									
		5	7.5	10	15	20	25	30	40	50	60
56C	L	176Q05L56	176Q07L56	176Q10L56	176Q15L56	176Q20L56	176Q25L56	176Q30L56	176Q40L56	176Q50L56	176Q60L56
	R	176Q05R56	176Q07R56	176Q10R56	176Q15R56	176Q20R56	176Q25R56	176Q30R56	176Q40R56	176Q50R56	176Q60R56
140TC	L	176Q05L14	176Q07L14	176Q10L14	176Q15L14	176Q20L14					
	R	176Q05R14	176Q07R14	176Q10R14	176Q15R14	176Q20R14					

Note: Reducers are shipped without a mounting base. Order bolt-on base kit **17BASE** if required.

SOLID OUTPUT

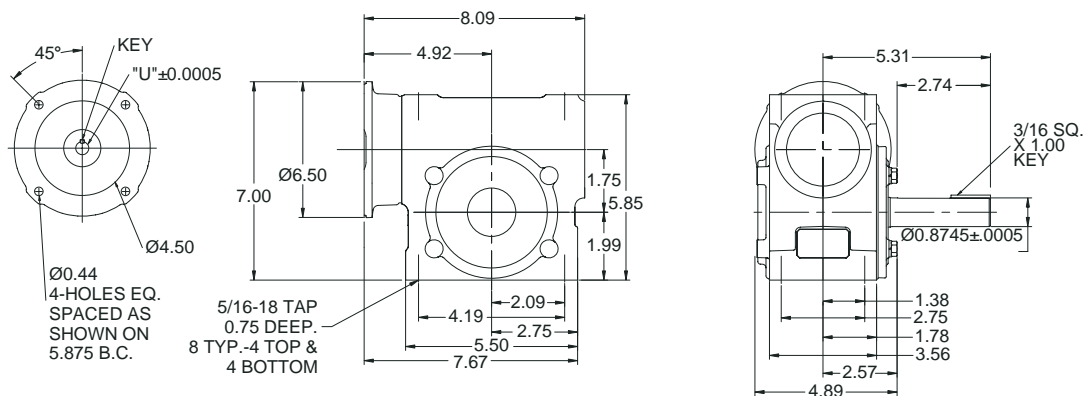

MOTOR FRAME	"U"	KEY
48Y 56C	.626	3/16 SQ. x 1.50 KEY
140TC 160ATC	.876	3/16 SQ x 1.50 KEY

MOUNTING POSITIONS

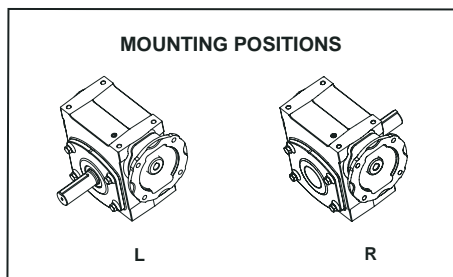

FEATURES/BENEFITS PAGE G4-2	SPECIFICATION PAGE G4-8	NOMENCLATURE PAGE G4-9	MODIFICATION/ACCESSORIES PAGE G4-90
--------------------------------	----------------------------	---------------------------	--

FEATURES/BENEFITS PAGE G4-2	SPECIFICATION PAGE G4-8	NOMENCLATURE PAGE G4-9	MODIFICATION/ACCESSORIES PAGE G4-90
--------------------------------	----------------------------	---------------------------	--

SELECTION/DIMENSIONS

DODGE®



TIGEAR-2 QUILL INPUT - SIZE 20

RATIO	OUTPUT RPM	RATING DATA		PART NUMBER		SHAFT POSITION
		1750 INPUT RPM		56C	140TC	
5	350	Mechanical Input Hp	3.47	20Q05L56	20Q05L14	L
		Thermal Input Hp	4.90	20Q05R56	20Q05R14	R
		Output Torque (lb in.)	581	20Q05LR56	20Q05LR14	LR
		Mechanical Output Hp	3.23	20Q05H56	20Q05H14	HOLLOW
		Output OHL (lbs.)	1380	20Q05HA56	20Q05HA14	HOLLOW ALT.
7.5	233	Mechanical Input Hp	2.78	20Q07L56	20Q07L14	L
		Thermal Input Hp	4.15	20Q07R56	20Q07R14	R
		Output Torque (lb in.)	678	20Q07LR56	20Q07LR14	LR
		Mechanical Output Hp	2.54	20Q07H56	20Q07H14	HOLLOW
		Output OHL (lbs.)	1560	20Q07HA56	20Q07HA14	HOLLOW ALT.
10	175	Mechanical Input Hp	2.25	20Q10L56	20Q10L14	L
		Thermal Input Hp	3.25	20Q10R56	20Q10R14	R
		Output Torque (lb in.)	725	20Q10LR56	20Q10LR14	LR
		Mechanical Output Hp	2.01	20Q10H56	20Q10H14	HOLLOW
		Output OHL (lbs.)	1560	20Q10HA56	20Q10HA14	HOLLOW ALT.
12.7	138	Mechanical Input Hp	1.90	20Q12L56	20Q12L14	L
		Thermal Input Hp	2.83	20Q12R56	20Q12R14	R
		Output Torque (lb in.)	770	20Q12LR56	20Q12LR14	LR
		Mechanical Output Hp	1.69	20Q12H56	20Q12H14	HOLLOW
		Output OHL (lbs.)	1560	20Q12HA56	20Q12HA14	HOLLOW ALT.
15	117	Mechanical Input Hp	1.69	20Q15L56	20Q15L14	L
		Thermal Input Hp	2.52	20Q15R56	20Q15R14	R
		Output Torque (lb in.)	790	20Q15LR56	20Q15LR14	LR
		Mechanical Output Hp	1.46	20Q15H56	20Q15H14	HOLLOW
		Output OHL (lbs.)	1560	20Q15HA56	20Q15HA14	HOLLOW ALT.
18	97	Mechanical Input Hp	1.46	20Q18L56	20Q18L14	L
		Thermal Input Hp	2.12	20Q18R56	20Q18R14	R
		Output Torque (lb in.)	795	20Q18LR56	20Q18LR14	LR
		Mechanical Output Hp	1.23	20Q18H56	20Q18H14	HOLLOW
		Output OHL (lbs.)	1560	20Q18HA56	20Q18HA14	HOLLOW ALT.
20	88	Mechanical Input Hp	1.34	20Q20L56	20Q20L14	L
		Thermal Input Hp	1.99	20Q20R56	20Q20R14	R
		Output Torque (lb in.)	796	20Q20LR56	20Q20LR14	LR
		Mechanical Output Hp	1.11	20Q20H56	20Q20H14	HOLLOW
		Output OHL (lbs.)	1560	20Q20HA56	20Q20HA14	HOLLOW ALT.
25	70	Mechanical Input Hp	1.11	20Q25L56	20Q25L14	L
		Thermal Input Hp	1.59	20Q25R56	20Q25R14	R
		Output Torque (lb in.)	788	20Q25LR56	20Q25LR14	LR
		Mechanical Output Hp	0.88	20Q25H56	20Q25H14	HOLLOW
		Output OHL (lbs.)	1560	20Q25HA56	20Q25HA14	HOLLOW ALT.
30	58	Mechanical Input Hp	0.96	20Q30L56		L
		Thermal Input Hp	1.49	20Q30R56		R
		Output Torque (lb in.)	802	20Q30LR56		LR
		Mechanical Output Hp	0.74	20Q30H56		HOLLOW
		Output OHL (lbs.)	1560	20Q30HA56		HOLLOW ALT.
40	44	Mechanical Input Hp	0.76	20Q40L56		L
		Thermal Input Hp	1.29	20Q40R56		R
		Output Torque (lb in.)	801	20Q40LR56		LR
		Mechanical Output Hp	0.56	20Q40H56		HOLLOW
		Output OHL (lbs.)	1560	20Q40HA56		HOLLOW ALT.
50	35	Mechanical Input Hp	0.64	20Q50L56		L
		Thermal Input Hp	1.09	20Q50R56		R
		Output Torque (lb in.)	787	20Q50LR56		LR
		Mechanical Output Hp	0.44	20Q50H56		HOLLOW
		Output OHL (lbs.)	1560	20Q50HA56		HOLLOW ALT.
60	29	Mechanical Input Hp	0.56	20Q60L56		L
		Thermal Input Hp	0.96	20Q60R56		R
		Output Torque (lb in.)	767	20Q60LR56		LR
		Mechanical Output Hp	0.36	20Q60H56		HOLLOW
		Output OHL (lbs.)	1560	20Q60HA56		HOLLOW ALT.

Note: Reducers are shipped without a mounting base. Order bolt-on base kit 20BASE if required.
Refer to page G4-96 for hollow bore bushing selections.

FEATURES/BENEFITS PAGE G4-2	SPECIFICATION PAGE G4-8	NOMENCLATURE PAGE G4-9	MODIFICATION/ACCESSORIES PAGE G4-90
--------------------------------	----------------------------	---------------------------	--

SELECTION/DIMENSIONS



TIGEAR-2 QUILL INPUT - SIZE 20

SOLID OUTPUT

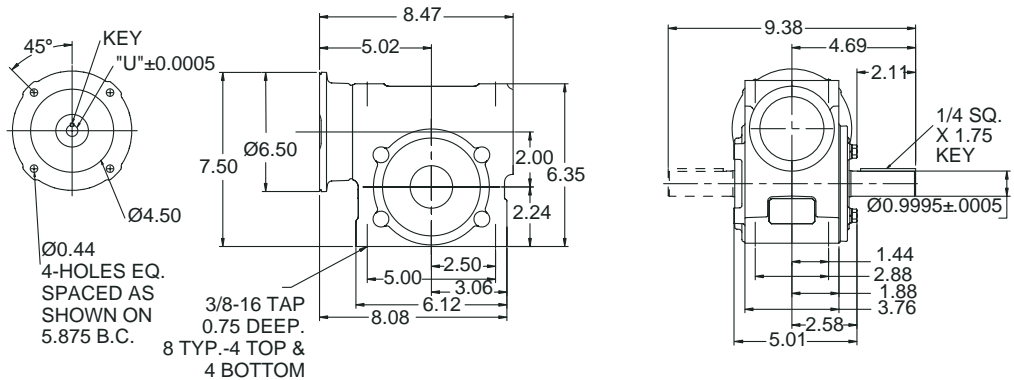

HOLLOW OUTPUT

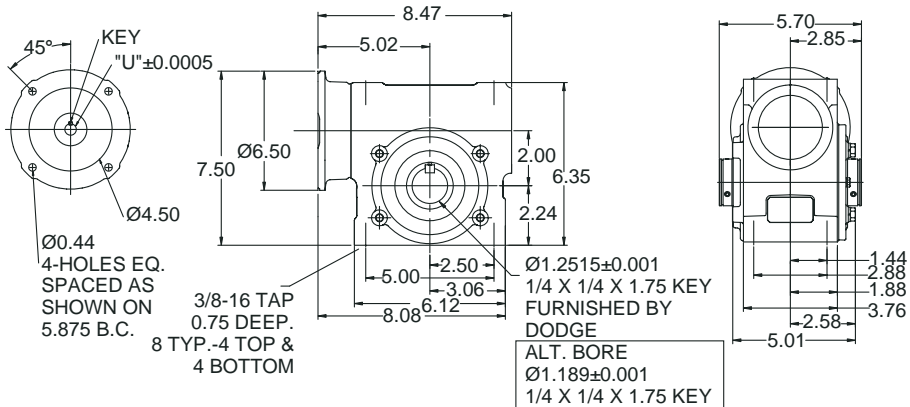

MOTOR FRAME	"U"	KEY
48Y 56C	.626	3/16 SQ. x 1.50 KEY
140TC 160ATC	.876	3/16 SQ x 1.50 KEY

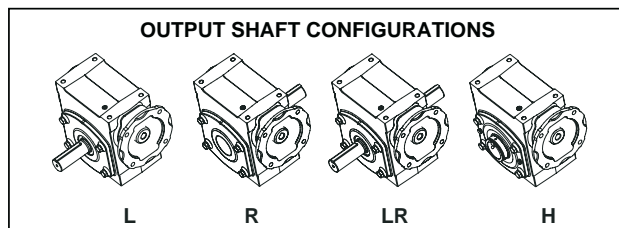

FEATURES/BENEFITS PAGE G4-2	SPECIFICATION PAGE G4-8	NOMENCLATURE PAGE G4-9	MODIFICATION/ACCESSORIES PAGE G4-90
--------------------------------	----------------------------	---------------------------	--

SELECTION/DIMENSIONS



TIGEAR-2 SEPARATE INPUT - SIZE 20

RATIO	OUTPUT RPM	RATING DATA 1750 INPUT RPM		SEPARATE REDUCER	SHAFT POSITION	OPTIONAL MOTOR ADAPTER KIT	
						56C	140TC
5	350	Mechanical Input Hp	3.47	20S05L	L	1720MTR56	1720MTR14
		Thermal Input Hp	4.90	20S05R	R		
		Output Torque (lb in.)	581	20S05LR	LR		
		Mechanical Output Hp	3.23	20S05H	HOLLOW		
		Output OHL (lbs.)	1380	20S05HA	HOLLOW ALT.		
7.5	233	Mechanical Input Hp	2.78	20S07L	L	1720MTR56	1720MTR14
		Thermal Input Hp	4.15	20S07R	R		
		Output Torque (lb in.)	678	20S07LR	LR		
		Mechanical Output Hp	2.54	20S07H	HOLLOW		
		Output OHL (lbs.)	1560	20S07HA	HOLLOW ALT.		
10	175	Mechanical Input Hp	2.25	20S10L	L	1720MTR56	1720MTR14
		Thermal Input Hp	3.25	20S10R	R		
		Output Torque (lb in.)	725	20S10LR	LR		
		Mechanical Output Hp	2.01	20S10H	HOLLOW		
		Output OHL (lbs.)	1560	20S10HA	HOLLOW ALT.		
12.7	138	Mechanical Input Hp	1.90	20S12L	L	1720MTR56	1720MTR14
		Thermal Input Hp	2.83	20S12R	R		
		Output Torque (lb in.)	770	20S12LR	LR		
		Mechanical Output Hp	1.69	20S12H	HOLLOW		
		Output OHL (lbs.)	1560	20S12HA	HOLLOW ALT.		
15	117	Mechanical Input Hp	1.69	20S15L	L	1720MTR56	1720MTR14
		Thermal Input Hp	2.52	20S15R	R		
		Output Torque (lb in.)	790	20S15LR	LR		
		Mechanical Output Hp	1.46	20S15H	HOLLOW		
		Output OHL (lbs.)	1560	20S15HA	HOLLOW ALT.		
18	97	Mechanical Input Hp	1.46	20S18L	L	1720MTR56	1720MTR14
		Thermal Input Hp	2.12	20S18R	R		
		Output Torque (lb in.)	795	20S18LR	LR		
		Mechanical Output Hp	1.23	20S18H	HOLLOW		
		Output OHL (lbs.)	1560	20S18HA	HOLLOW ALT.		
20	88	Mechanical Input Hp	1.34	20S20L	L	1720MTR56	1720MTR14
		Thermal Input Hp	1.99	20S20R	R		
		Output Torque (lb in.)	796	20S20LR	LR		
		Mechanical Output Hp	1.11	20S20H	HOLLOW		
		Output OHL (lbs.)	1560	20S20HA	HOLLOW ALT.		
25	70	Mechanical Input Hp	1.11	20S25L	L	1720MTR56	1720MTR14
		Thermal Input Hp	1.59	20S25R	R		
		Output Torque (lb in.)	788	20S25LR	LR		
		Mechanical Output Hp	0.88	20S25H	HOLLOW		
		Output OHL (lbs.)	1560	20S25HA	HOLLOW ALT.		
30	58	Mechanical Input Hp	0.96	20S30L	L	1720MTR56	
		Thermal Input Hp	1.49	20S30R	R		
		Output Torque (lb in.)	802	20S30LR	LR		
		Mechanical Output Hp	0.74	20S30H	HOLLOW		
		Output OHL (lbs.)	1560	20S30HA	HOLLOW ALT.		
40	44	Mechanical Input Hp	0.76	20S40L	L	1720MTR56	
		Thermal Input Hp	1.29	20S40R	R		
		Output Torque (lb in.)	801	20S40LR	LR		
		Mechanical Output Hp	0.56	20S40H	HOLLOW		
		Output OHL (lbs.)	1560	20S40HA	HOLLOW ALT.		
50	35	Mechanical Input Hp	0.64	20S50L	L	1720MTR56	
		Thermal Input Hp	1.09	20S50R	R		
		Output Torque (lb in.)	787	20S50LR	LR		
		Mechanical Output Hp	0.44	20S50H	HOLLOW		
		Output OHL (lbs.)	1560	20S50HA	HOLLOW ALT.		
60	29	Mechanical Input Hp	0.56	20S60L	L	1720MTR56	
		Thermal Input Hp	0.96	20S60R	R		
		Output Torque (lb in.)	767	20S60LR	LR		
		Mechanical Output Hp	0.36	20S60H	HOLLOW		
		Output OHL (lbs.)	1560	20S60HA	HOLLOW ALT.		
All Ratios		Input OHL (lbs)	200	One diameter from seal surface			

Note: TIGEAR-2 separate reducers cannot be used with the old Adaptable TIGEAR motor adapter kits.
Refer to page G4-96 for hollow bore bushing selections.

FEATURES/BENEFITS PAGE G4-2	SPECIFICATION PAGE G4-8	NOMENCLATURE PAGE G4-9	MODIFICATION/ACCESSORIES PAGE G4-90
--------------------------------	----------------------------	---------------------------	--

SELECTION/DIMENSIONS



Gearing Reference Guide

TORQUE-ARM II

TORQUE-ARM

MAXIMUM Concentric Reducer

TIGEAR-2

TIGEAR-2 SEPARATE INPUT - SIZE 20

SOLID OUTPUT

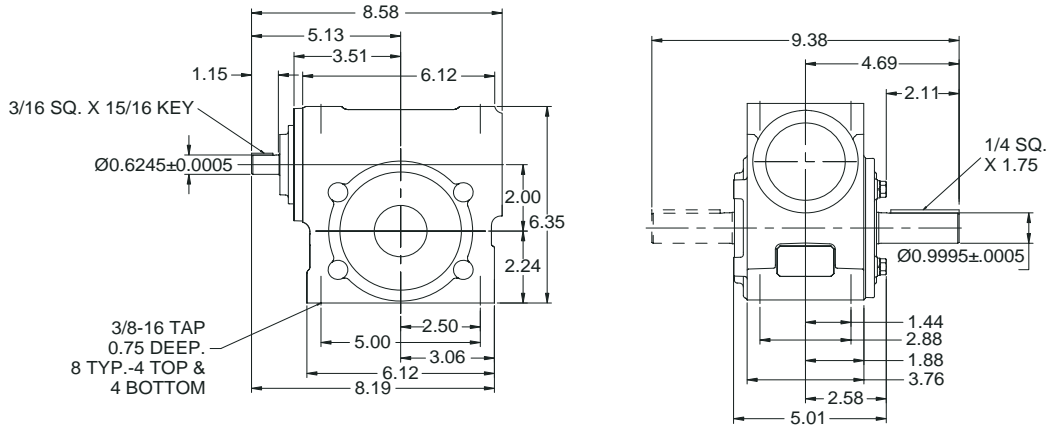

HOLLOW OUTPUT

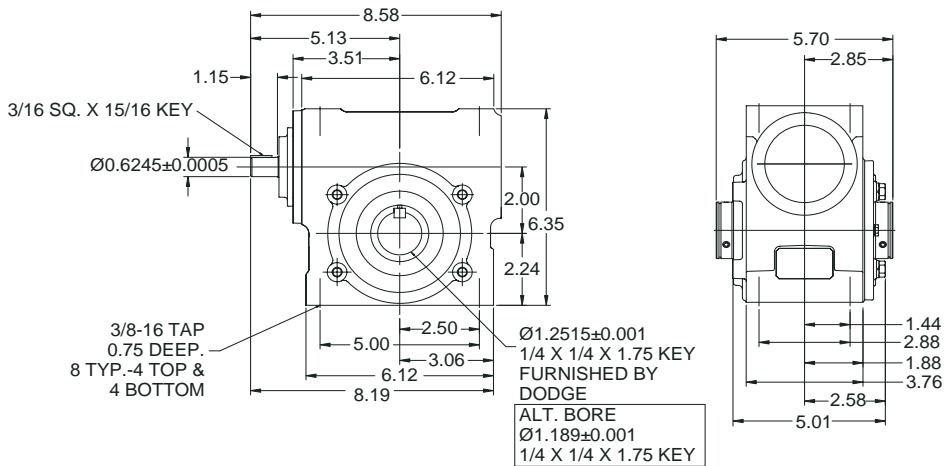

OUTPUT SHAFT CONFIGURATIONS

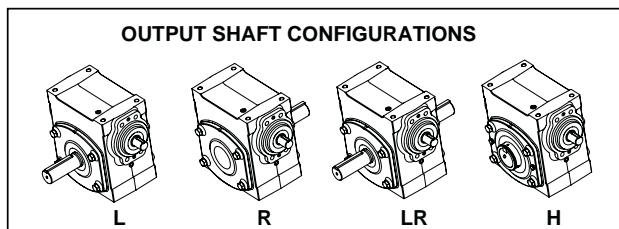

FEATURES/BENEFITS PAGE G4-2	SPECIFICATION PAGE G4-8	NOMENCLATURE PAGE G4-9	MODIFICATION/ACCESSORIES PAGE G4-90
--------------------------------	----------------------------	---------------------------	--

SELECTION/DIMENSIONS

DODGE®



TIGEAR-2 COUPLED INPUT - ADAPTER ASSEMBLY - SIZE 20

Coupled input units include a Separate reducer and motor adapter kit assembled together.

These assemblies are normally "made to order" with a 5 day standard lead time.

RATIO	OUTPUT RPM	RATING DATA 1750 INPUT RPM		PART NUMBER		SHAFT POSITION
				56C	140TC	
5	350	Mechanical Input Hp	3.47	20A05L56	20A05L14	L
		Thermal Input Hp	4.90	20A05R56	20A05R14	R
		Output Torque (lb in.)	581	20A05LR56	20A05LR14	LR
		Mechanical Output Hp	3.23	20A05H56	20A05H14	HOLLOW
		Output OHL (lbs.)	1380	20A05HA56	20A05HA14	HOLLOW ALT.
7.5	233	Mechanical Input Hp	2.78	20A07L56	20A07L14	L
		Thermal Input Hp	4.15	20A07R56	20A07R14	R
		Output Torque (lb in.)	678	20A07LR56	20A07LR14	LR
		Mechanical Output Hp	2.54	20A07H56	20A07H14	HOLLOW
		Output OHL (lbs.)	1560	20A07HA56	20A07HA14	HOLLOW ALT.
10	175	Mechanical Input Hp	2.25	20A10L56	20A10L14	L
		Thermal Input Hp	3.25	20A10R56	20A10R14	R
		Output Torque (lb in.)	725	20A10LR56	20A10LR14	LR
		Mechanical Output Hp	2.01	20A10H56	20A10H14	HOLLOW
		Output OHL (lbs.)	1560	20A10HA56	20A10HA14	HOLLOW ALT.
12.7	138	Mechanical Input Hp	1.90	20A12L56	20A12L14	L
		Thermal Input Hp	2.83	20A12R56	20A12R14	R
		Output Torque (lb in.)	770	20A12LR56	20A12LR14	LR
		Mechanical Output Hp	1.69	20A12H56	20A12H14	HOLLOW
		Output OHL (lbs.)	1560	20A12HA56	20A12HA14	HOLLOW ALT.
15	117	Mechanical Input Hp	1.69	20A15L56	20A15L14	L
		Thermal Input Hp	2.52	20A15R56	20A15R14	R
		Output Torque (lb in.)	790	20A15LR56	20A15LR14	LR
		Mechanical Output Hp	1.46	20A15H56	20A15H14	HOLLOW
		Output OHL (lbs.)	1560	20A15HA56	20A15HA14	HOLLOW ALT.
18	97	Mechanical Input Hp	1.46	20A18L56	20A18L14	L
		Thermal Input Hp	2.12	20A18R56	20A18R14	R
		Output Torque (lb in.)	795	20A18LR56	20A18LR14	LR
		Mechanical Output Hp	1.23	20A18H56	20A18H14	HOLLOW
		Output OHL (lbs.)	1560	20A18HA56	20A18HA14	HOLLOW ALT.
20	88	Mechanical Input Hp	1.34	20A20L56	20A20L14	L
		Thermal Input Hp	1.99	20A20R56	20A20R14	R
		Output Torque (lb in.)	796	20A20LR56	20A20LR14	LR
		Mechanical Output Hp	1.11	20A20H56	20A20H14	HOLLOW
		Output OHL (lbs.)	1560	20A20HA56	20A20HA14	HOLLOW ALT.
25	70	Mechanical Input Hp	1.11	20A25L56	20A25L14	L
		Thermal Input Hp	1.59	20A25R56	20A25R14	R
		Output Torque (lb in.)	788	20A25LR56	20A25LR14	LR
		Mechanical Output Hp	0.88	20A25H56	20A25H14	HOLLOW
		Output OHL (lbs.)	1560	20A25HA56	20A25HA14	HOLLOW ALT.
30	58	Mechanical Input Hp	0.96	20A30L56		L
		Thermal Input Hp	1.49	20A30R56		R
		Output Torque (lb in.)	802	20A30LR56		LR
		Mechanical Output Hp	0.74	20A30H56		HOLLOW
		Output OHL (lbs.)	1560	20A30HA56		HOLLOW ALT.
40	44	Mechanical Input Hp	0.76	20A40L56		L
		Thermal Input Hp	1.29	20A40R56		R
		Output Torque (lb in.)	801	20A40LR56		LR
		Mechanical Output Hp	0.56	20A40H56		HOLLOW
		Output OHL (lbs.)	1560	20A40HA56		HOLLOW ALT.
50	35	Mechanical Input Hp	0.64	20A50L56		L
		Thermal Input Hp	1.09	20A50R56		R
		Output Torque (lb in.)	787	20A50LR56		LR
		Mechanical Output Hp	0.44	20A50H56		HOLLOW
		Output OHL (lbs.)	1560	20A50HA56		HOLLOW ALT.
60	29	Mechanical Input Hp	0.56	20A60L56		L
		Thermal Input Hp	0.96	20A60R56		R
		Output Torque (lb in.)	767	20A60LR56		LR
		Mechanical Output Hp	0.36	20A60H56		HOLLOW
		Output OHL (lbs.)	1560	20A60HA56		HOLLOW ALT.

Note: Reducers are shipped without a mounting base. Order bolt-on base kit **20BASE** if required.

Refer to page G4-96 for hollow bore bushing selections.

FEATURES/BENEFITS PAGE G4-2	SPECIFICATION PAGE G4-8	NOMENCLATURE PAGE G4-9	MODIFICATION/ACCESSORIES PAGE G4-90
--------------------------------	----------------------------	---------------------------	--

SELECTION/DIMENSIONS



TIGEAR-2 COUPLED INPUT - ADAPTER ASSEMBLY - SIZE 20

SOLID OUTPUT

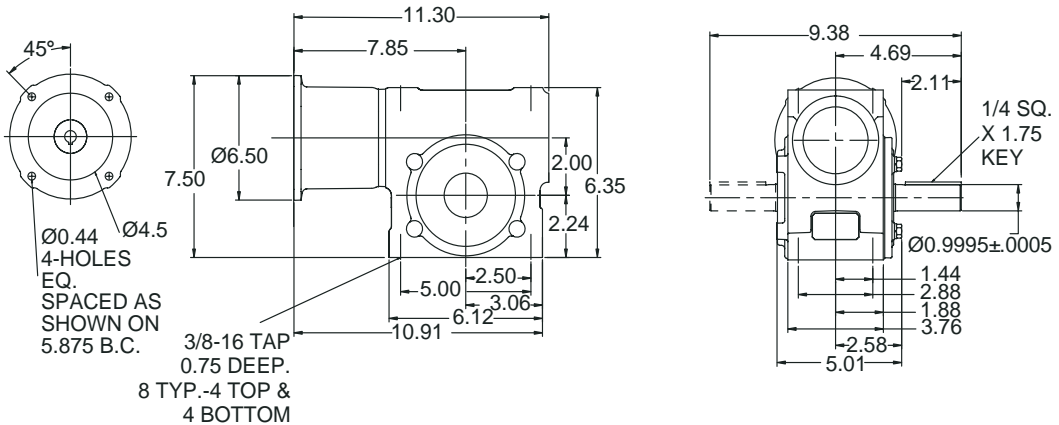

HOLLOW OUTPUT

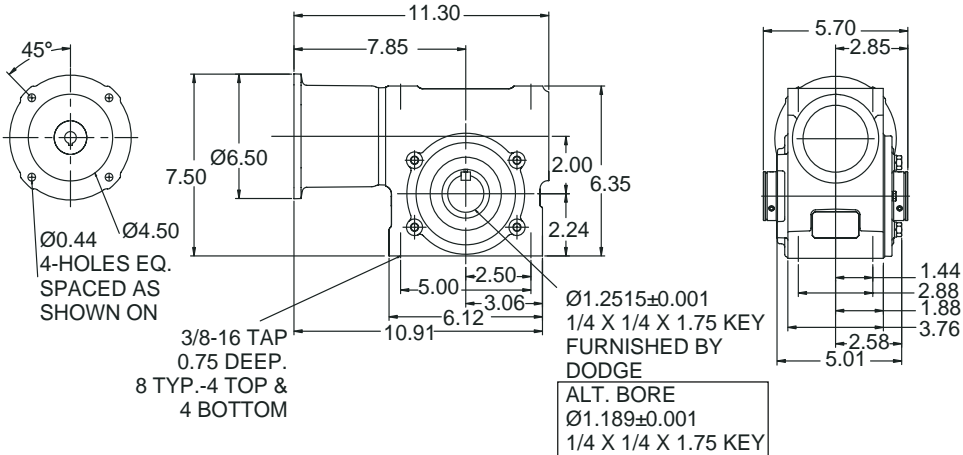

OUTPUT SHAFT CONFIGURATIONS

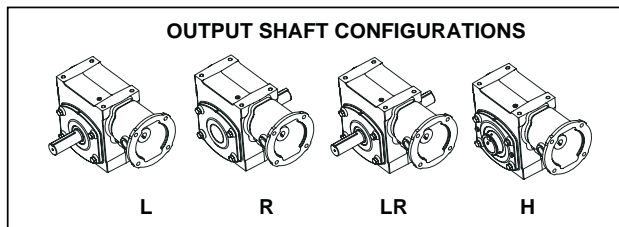

FEATURES/BENEFITS PAGE G4-2	SPECIFICATION PAGE G4-8	NOMENCLATURE PAGE G4-9	MODIFICATION/ACCESSORIES PAGE G4-90
--------------------------------	----------------------------	---------------------------	--

SELECTION/DIMENSIONS

TIGEAR-2 QUILL INPUT - SIZE 202

SIZE 20 WITH 2" EXTENDED LENGTH OUTPUT SHAFT

MOTOR FRAME	SHAFT POSITION	RATIO									
		5	7.5	10	15	20	25	30	40	50	60
56C	L	202Q05L56	202Q07L56	202Q10L56	202Q15L56	202Q20L56	202Q25L56	202Q30L56	202Q40L56	202Q50L56	202Q60L56
	R	202Q05R56	202Q07R56	202Q10R56	202Q15R56	202Q20R56	202Q25R56	202Q30R56	202Q40R56	202Q50R56	202Q60R56
140TC	L	202Q05L14	202Q07L14	202Q10L14	202Q15L14	202Q20L14	202Q25L14				
	R	202Q05R14	202Q07R14	202Q10R14	202Q15R14	202Q20R14	202Q25R14				

Note: Reducers are shipped without a mounting base. Order bolt-on base kit **20BASE** if required

SOLID OUTPUT

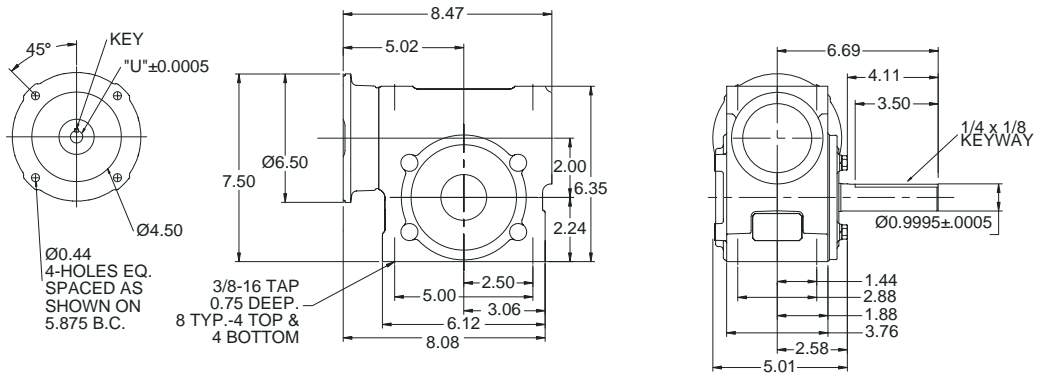

MOTOR FRAME	"U"	KEY
48Y 56C	.626	3/16 SQ. x 1.50 KEY
140TC 160ATC	.876	3/16 SQ x 1.50 KEY

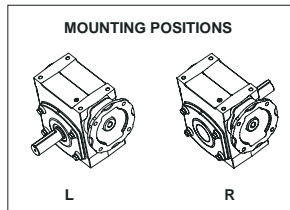

FEATURES/BENEFITS PAGE G4-2	SPECIFICATION PAGE G4-8	NOMENCLATURE PAGE G4-9	MODIFICATION/ACCESSORIES PAGE G4-90
--------------------------------	----------------------------	---------------------------	--

SELECTION/DIMENSIONS



TIGEAR-2 QUILL INPUT - SIZE 23

RATIO	OUTPUT RPM	RATING DATA 1750 INPUT RPM		PART NUMBER			SHAFT POSITION
				56C	140TC	180TC	
5	350	Mechanical Input Hp	5.25	23Q05L56	23Q05L14	23Q05L18	L
		Thermal Input Hp	6.61	23Q05R56	23Q05R14	23Q05R18	R
		Output Torque (lb in.)	881	23Q05LR56	23Q05LR14	23Q05LR18	LR
		Mechanical Output Hp	4.89	23Q05H56	23Q05H14	23Q05H18	HOLLOW
		Output OHL (lbs.)	1330	23Q05HA56	23Q05HA14	23Q05HA18	HOLLOW ALT.
7.5	233	Mechanical Input Hp	4.18	23Q07L56	23Q07L14	23Q07L18	L
		Thermal Input Hp	5.64	23Q07R56	23Q07R14	23Q07R18	R
		Output Torque (lb in.)	1026	23Q07LR56	23Q07LR14	23Q07LR18	LR
		Mechanical Output Hp	3.85	23Q07H56	23Q07H14	23Q07H18	HOLLOW
		Output OHL (lbs.)	1520	23Q07HA56	23Q07HA14	23Q07HA18	HOLLOW ALT.
10	175	Mechanical Input Hp	3.42	23Q10L56	23Q10L14	23Q10L18	L
		Thermal Input Hp	4.40	23Q10R56	23Q10R14	23Q10R18	R
		Output Torque (lb in.)	1106	23Q10LR56	23Q10LR14	23Q10LR18	LR
		Mechanical Output Hp	3.07	23Q10H56	23Q10H14	23Q10H18	HOLLOW
		Output OHL (lbs.)	1610	23Q10HA56	23Q10HA14	23Q10HA18	HOLLOW ALT.
12.7	138	Mechanical Input Hp	2.91	23Q12L56	23Q12L14	23Q12L18	L
		Thermal Input Hp	3.78	23Q12R56	23Q12R14	23Q12R18	R
		Output Torque (lb in.)	1170	23Q12LR56	23Q12LR14	23Q12LR18	LR
		Mechanical Output Hp	2.56	23Q12H56	23Q12H14	23Q12H18	HOLLOW
		Output OHL (lbs.)	1610	23Q12HA56	23Q12HA14	23Q12HA18	HOLLOW ALT.
15	117	Mechanical Input Hp	2.57	23Q15L56	23Q15L14		L
		Thermal Input Hp	3.30	23Q15R56	23Q15R14		R
		Output Torque (lb in.)	1199	23Q15LR56	23Q15LR14		LR
		Mechanical Output Hp	2.22	23Q15H56	23Q15H14		HOLLOW
		Output OHL (lbs.)	1610	23Q15HA56	23Q15HA14		HOLLOW ALT.
20	88	Mechanical Input Hp	2.00	23Q20L56	23Q20L14		L
		Thermal Input Hp	2.62	23Q20R56	23Q20R14		R
		Output Torque (lb in.)	1178	23Q20LR56	23Q20LR14		LR
		Mechanical Output Hp	1.64	23Q20H56	23Q20H14		HOLLOW
		Output OHL (lbs.)	1610	23Q20HA56	23Q20HA14		HOLLOW ALT.
25	70	Mechanical Input Hp	1.65	23Q25L56	23Q25L14		L
		Thermal Input Hp	2.16	23Q25R56	23Q25R14		R
		Output Torque (lb in.)	1184	23Q25LR56	23Q25LR14		LR
		Mechanical Output Hp	1.32	23Q25H56	23Q25H14		HOLLOW
		Output OHL (lbs.)	1610	23Q25HA56	23Q25HA14		HOLLOW ALT.
30	58	Mechanical Input Hp	1.42	23Q30L56	23Q30L14		L
		Thermal Input Hp	2.06	23Q30R56	23Q30R14		R
		Output Torque (lb in.)	1201	23Q30LR56	23Q30LR14		LR
		Mechanical Output Hp	1.11	23Q30H56	23Q30H14		HOLLOW
		Output OHL (lbs.)	1610	23Q30HA56	23Q30HA14		HOLLOW ALT.
40	44	Mechanical Input Hp	1.11	23Q40L56	23Q40L14		L
		Thermal Input Hp	1.73	23Q40R56	23Q40R14		R
		Output Torque (lb in.)	1193	23Q40LR56	23Q40LR14		LR
		Mechanical Output Hp	0.83	23Q40H56	23Q40H14		HOLLOW
		Output OHL (lbs.)	1610	23Q40HA56	23Q40HA14		HOLLOW ALT.
50	35	Mechanical Input Hp	0.95	23Q50L56			L
		Thermal Input Hp	1.42	23Q50R56			R
		Output Torque (lb in.)	1182	23Q50LR56			LR
		Mechanical Output Hp	0.66	23Q50H56			HOLLOW
		Output OHL (lbs.)	1610	23Q50HA56			HOLLOW ALT.
60	29	Mechanical Input Hp	0.80	23Q60L56			L
		Thermal Input Hp	1.24	23Q60R56			R
		Output Torque (lb in.)	1111	23Q60LR56			LR
		Mechanical Output Hp	0.51	23Q60H56			HOLLOW
		Output OHL (lbs.)	1610	23Q60HA56			HOLLOW ALT.

Note: Reducers are shipped without a mounting base. Order bolt-on base kit **23BASE** if required.

Refer to page G4-96 for hollow bore bushing selections

FEATURES/BENEFITS PAGE G4-2	SPECIFICATION PAGE G4-8	NOMENCLATURE PAGE G4-9	MODIFICATION/ACCESSORIES PAGE G4-90
--------------------------------	----------------------------	---------------------------	--

SELECTION/DIMENSIONS



TIGEAR-2 QUILL INPUT - SIZE 23

SOLID OUTPUT

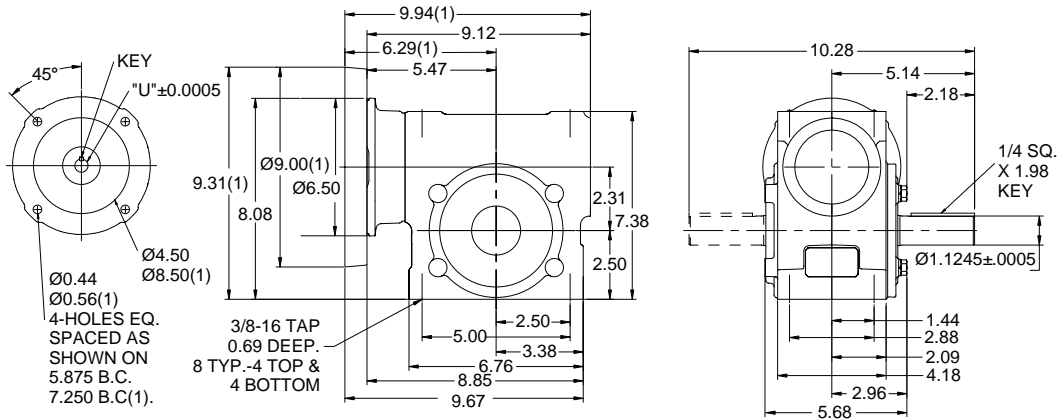

(1) DIMENSIONS APPLY TO 180 FRAME MOTOR ADAPTER

HOLLOW OUTPUT

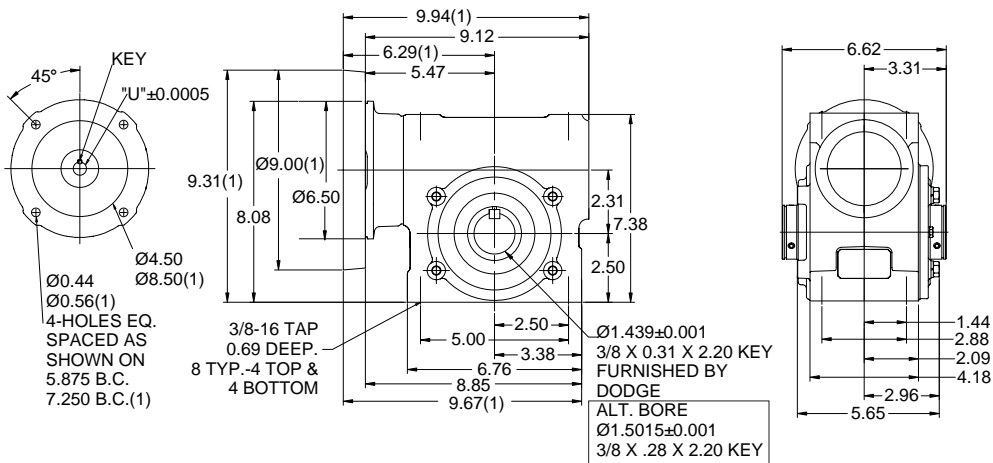

MOTOR FRAME	"U"	KEY
48Y 56C	.6255	3/16 SQ. x 1.50 KEY
140TC 160ATC	.8755	3/16 SQ x 1.50 KEY
180TC 180ATC	1.1255	1/4 SQ x 2.00 KEY

OUTPUT SHAFT CONFIGURATIONS

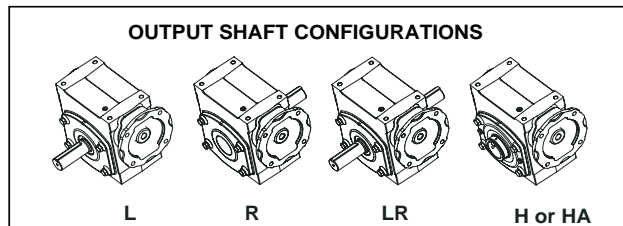

FEATURES/BENEFITS PAGE G4-2	SPECIFICATION PAGE G4-8	NOMENCLATURE PAGE G4-9	MODIFICATION/ACCESSORIES PAGE G4-90
--------------------------------	----------------------------	---------------------------	--

SELECTION/DIMENSIONS

DODGE®



TIGEAR-2 SEPARATE INPUT - SIZE 23

RATIO	OUTPUT RPM	RATING DATA		SEPARATE REDUCER	SHAFT POSITION	OPTIONAL MOTOR ADAPTER KIT		
		1750 INPUT RPM				56C	140TC	180TC
5	350	Mechanical Input Hp	5.25	23S05L	L	2330MTR56	2330MTR14	2330MTR18
		Thermal Input Hp	6.61	23S05R	R			
		Output Torque (lb in.)	881	23S05LR	LR			
		Mechanical Output Hp	4.89	23S05H	HOLLOW			
		Output OHL (lbs.)	1330	23S05HA	HOLLOW ALT.			
7.5	233	Mechanical Input Hp	4.18	23S07L	L	2330MTR56	2330MTR14	2330MTR18
		Thermal Input Hp	5.64	23S07R	R			
		Output Torque (lb in.)	1026	23S07LR	LR			
		Mechanical Output Hp	3.85	23S07H	HOLLOW			
		Output OHL (lbs.)	1520	23S07HA	HOLLOW ALT.			
10	175	Mechanical Input Hp	3.42	23S10L	L	2330MTR56	2330MTR14	2330MTR18
		Thermal Input Hp	4.40	23S10R	R			
		Output Torque (lb in.)	1106	23S10LR	LR			
		Mechanical Output Hp	3.07	23S10H	HOLLOW			
		Output OHL (lbs.)	1610	23S10HA	HOLLOW ALT.			
12.7	138	Mechanical Input Hp	2.91	23S12L	L	2330MTR56	2330MTR14	2330MTR18
		Thermal Input Hp	3.78	23S12R	R			
		Output Torque (lb in.)	1170	23S12LR	LR			
		Mechanical Output Hp	2.56	23S12H	HOLLOW			
		Output OHL (lbs.)	1610	23S12HA	HOLLOW ALT.			
15	117	Mechanical Input Hp	2.57	23S15L	L	2330MTR56	2330MTR14	
		Thermal Input Hp	3.30	23S15R	R			
		Output Torque (lb in.)	1199	23S15LR	LR			
		Mechanical Output Hp	2.22	23S15H	HOLLOW			
		Output OHL (lbs.)	1610	23S15HA	HOLLOW ALT.			
20	88	Mechanical Input Hp	2.00	23S20L	L	2330MTR56	2330MTR14	
		Thermal Input Hp	2.62	23S20R	R			
		Output Torque (lb in.)	1178	23S20LR	LR			
		Mechanical Output Hp	1.64	23S20H	HOLLOW			
		Output OHL (lbs.)	1610	23S20HA	HOLLOW ALT.			
25	70	Mechanical Input Hp	1.65	23S25L	L	2330MTR56	2330MTR14	
		Thermal Input Hp	2.16	23S25R	R			
		Output Torque (lb in.)	1184	23S25LR	LR			
		Mechanical Output Hp	1.32	23S25H	HOLLOW			
		Output OHL (lbs.)	1610	23S25HA	HOLLOW ALT.			
30	58	Mechanical Input Hp	1.42	23S30L	L	2330MTR56	2330MTR14	
		Thermal Input Hp	2.06	23S30R	R			
		Output Torque (lb in.)	1201	23S30LR	LR			
		Mechanical Output Hp	1.11	23S30H	HOLLOW			
		Output OHL (lbs.)	1610	23S30HA	HOLLOW ALT.			
40	44	Mechanical Input Hp	1.11	23S40L	L	2330MTR56	2330MTR14	
		Thermal Input Hp	1.73	23S40R	R			
		Output Torque (lb in.)	1193	23S40LR	LR			
		Mechanical Output Hp	0.83	23S40H	HOLLOW			
		Output OHL (lbs.)	1610	23S40HA	HOLLOW ALT.			
50	35	Mechanical Input Hp	0.95	23S50L	L	2330MTR56		
		Thermal Input Hp	1.42	23S50R	R			
		Output Torque (lb in.)	1182	23S50LR	LR			
		Mechanical Output Hp	0.66	23S50H	HOLLOW			
		Output OHL (lbs.)	1610	23S50HA	HOLLOW ALT.			
60	29	Mechanical Input Hp	0.80	23S60L	L	2330MTR56		
		Thermal Input Hp	1.24	23S60R	R			
		Output Torque (lb in.)	1111	23S60LR	LR			
		Mechanical Output Hp	0.51	23S60H	HOLLOW			
		Output OHL (lbs.)	1610	23S60HA	HOLLOW ALT.			
All Ratios		Input OHL (lbs)	200	One diameter from seal surface				

Note: TIGEAR-2 separate reducers cannot be used with the old Adaptable TIGEAR motor adapter kits.

Refer to page G4-96 for hollow bore bushing selections

FEATURES/BENEFITS PAGE G4-2	SPECIFICATION PAGE G4-8	NOMENCLATURE PAGE G4-9	MODIFICATION/ACCESSORIES PAGE G4-90
--------------------------------	----------------------------	---------------------------	--

SELECTION/DIMENSIONS



TIGEAR-2 SEPARATE INPUT - SIZE 23

SOLID OUTPUT

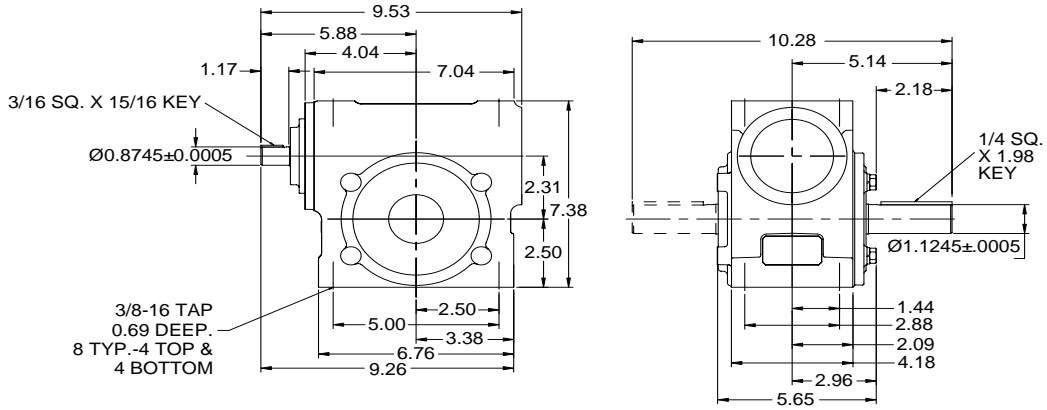

HOLLOW OUTPUT

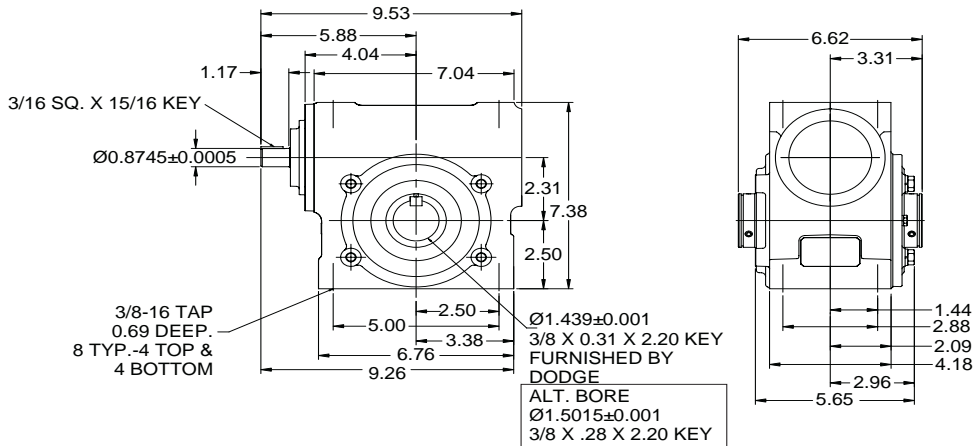

OUTPUT SHAFT CONFIGURATIONS

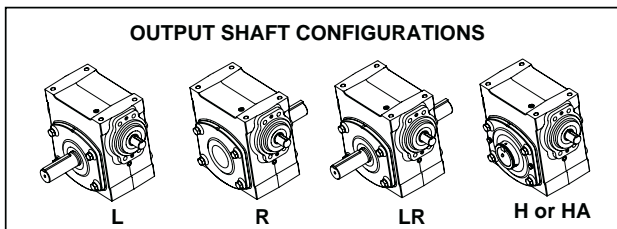

FEATURES/BENEFITS PAGE G4-2	SPECIFICATION PAGE G4-8	NOMENCLATURE PAGE G4-9	MODIFICATION/ACCESSORIES PAGE G4-90
--------------------------------	----------------------------	---------------------------	--

SELECTION/DIMENSIONS



TIGEAR-2 COUPLED INPUT - ADAPTER ASSEMBLY - SIZE 23

Coupled input units include a Separate reducer and motor adapter kit assembled together.

These assemblies are normally "made to order" with a 5 day standard lead time.

RATIO	OUTPUT RPM	RATING DATA 1750 INPUT RPM		PART NUMBER			SHAFT POSITION
				56C	140TC	180TC	
5	350	Mechanical Input Hp	5.25	23A05L56	23A05L14	23A05L18	L
		Thermal Input Hp	6.61	23A05R56	23A05R14	23A05R18	R
		Output Torque (lb in.)	881	23A05LR56	23A05LR14	23A05LR18	LR
		Mechanical Output Hp	4.89	23A05H56	23A05H14	23A05H18	HOLLOW
		Output OHL (lbs.)	1330	23A05HA56	23A05HA14	23A05HA18	HOLLOW ALT.
7.5	233	Mechanical Input Hp	4.18	23A07L56	23A07L14	23A07L18	L
		Thermal Input Hp	5.64	23A07R56	23A07R14	23A07R18	R
		Output Torque (lb in.)	1026	23A07LR56	23A07LR14	23A07LR18	LR
		Mechanical Output Hp	3.85	23A07H56	23A07H14	23A07H18	HOLLOW
		Output OHL (lbs.)	1520	23A07HA56	23A07HA14	23A07HA18	HOLLOW ALT.
10	175	Mechanical Input Hp	3.42	23A10L56	23A10L14	23A10L18	L
		Thermal Input Hp	4.40	23A10R56	23A10R14	23A10R18	R
		Output Torque (lb in.)	1106	23A10LR56	23A10LR14	23A10LR18	LR
		Mechanical Output Hp	3.07	23A10H56	23A10H14	23A10H18	HOLLOW
		Output OHL (lbs.)	1610	23A10HA56	23A10HA14	23A10HA18	HOLLOW ALT.
12.7	138	Mechanical Input Hp	2.91	23A12L56	23A12L14	23A12L18	L
		Thermal Input Hp	3.78	23A12R56	23A12R14	23A12R18	R
		Output Torque (lb in.)	1170	23A12LR56	23A12LR14	23A12LR18	LR
		Mechanical Output Hp	2.56	23A12H56	23A12H14	23A12H18	HOLLOW
		Output OHL (lbs.)	1610	23A12HA56	23A12HA14	23A12HA18	HOLLOW ALT.
15	117	Mechanical Input Hp	2.57	23A15L56	23A15L14	23A15L18	L
		Thermal Input Hp	3.30	23A15R56	23A15R14	23A15R18	R
		Output Torque (lb in.)	1199	23A15LR56	23A15LR14	23A15LR18	LR
		Mechanical Output Hp	2.22	23A15H56	23A15H14	23A15H18	HOLLOW
		Output OHL (lbs.)	1610	23A15HA56	23A15HA14	23A15HA18	HOLLOW ALT.
20	88	Mechanical Input Hp	2.00	23A20L56	23A20L14	23A20L18	L
		Thermal Input Hp	2.62	23A20R56	23A20R14	23A20R18	R
		Output Torque (lb in.)	1178	23A20LR56	23A20LR14	23A20LR18	LR
		Mechanical Output Hp	1.64	23A20H56	23A20H14	23A20H18	HOLLOW
		Output OHL (lbs.)	1610	23A20HA56	23A20HA14	23A20HA18	HOLLOW ALT.
25	70	Mechanical Input Hp	1.65	23A25L56	23A25L14	23A25L18	L
		Thermal Input Hp	2.16	23A25R56	23A25R14	23A25R18	R
		Output Torque (lb in.)	1184	23A25LR56	23A25LR14	23A25LR18	LR
		Mechanical Output Hp	1.32	23A25H56	23A25H14	23A25H18	HOLLOW
		Output OHL (lbs.)	1610	23A25HA56	23A25HA14	23A25HA18	HOLLOW ALT.
30	58	Mechanical Input Hp	1.42	23A30L56	23A30L14	23A30L18	L
		Thermal Input Hp	2.06	23A30R56	23A30R14	23A30R18	R
		Output Torque (lb in.)	1201	23A30LR56	23A30LR14	23A30LR18	LR
		Mechanical Output Hp	1.11	23A30H56	23A30H14	23A30H18	HOLLOW
		Output OHL (lbs.)	1610	23A30HA56	23A30HA14	23A30HA18	HOLLOW ALT.
40	44	Mechanical Input Hp	1.11	23A40L56	23A40L14	23A40L18	L
		Thermal Input Hp	1.73	23A40R56	23A40R14	23A40R18	R
		Output Torque (lb in.)	1193	23A40LR56	23A40LR14	23A40LR18	LR
		Mechanical Output Hp	0.83	23A40H56	23A40H14	23A40H18	HOLLOW
		Output OHL (lbs.)	1610	23A40HA56	23A40HA14	23A40HA18	HOLLOW ALT.
50	35	Mechanical Input Hp	0.95	23A50L56			L
		Thermal Input Hp	1.42	23A50R56			R
		Output Torque (lb in.)	1182	23A50LR56			LR
		Mechanical Output Hp	0.66	23A50H56			HOLLOW
		Output OHL (lbs.)	1610	23A50HA56			HOLLOW ALT.
60	29	Mechanical Input Hp	0.80	23A60L56			L
		Thermal Input Hp	1.24	23A60R56			R
		Output Torque (lb in.)	1111	23A60LR56			LR
		Mechanical Output Hp	0.51	23A60H56			HOLLOW
		Output OHL (lbs.)	1610	23A60HA56			HOLLOW ALT.

Note: Reducers are shipped without a mounting base. Order bolt-on base kit **23BASE** if required.

Refer to page G4-96 for hollow bore bushing selections

FEATURES/BENEFITS PAGE G4-2	SPECIFICATION PAGE G4-8	NOMENCLATURE PAGE G4-9	MODIFICATION/ACCESSORIES PAGE G4-90
--------------------------------	----------------------------	---------------------------	--

SELECTION/DIMENSIONS



TIGEAR-2 COUPLED INPUT - SIZE 23

SOLID OUTPUT

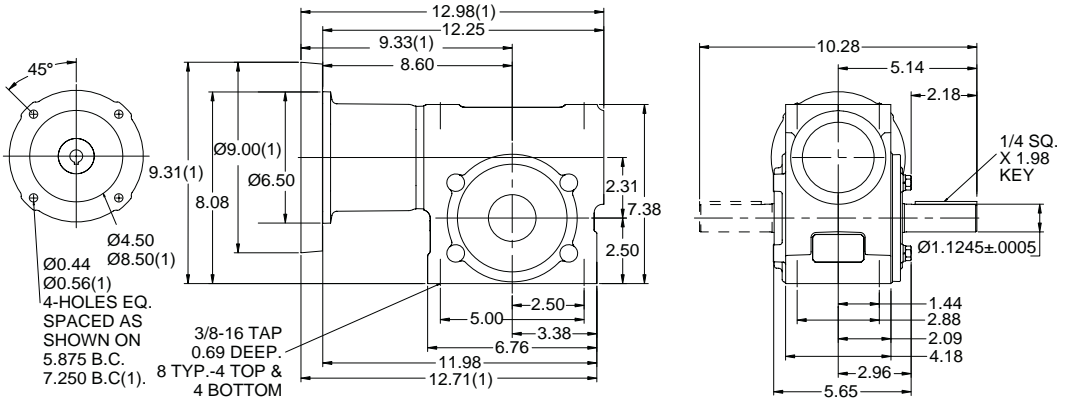

(1) DIMENSIONS APPLY TO 180 FRAME MOTOR ADAPTER

HOLLOW OUTPUT

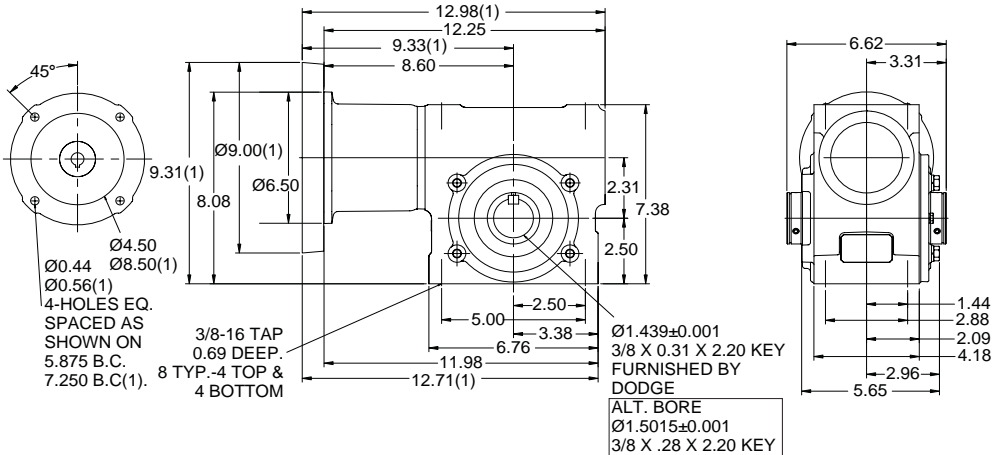

OUTPUT SHAFT CONFIGURATIONS

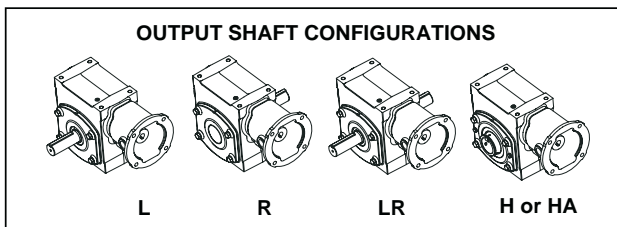

FEATURES/BENEFITS PAGE G4-2	SPECIFICATION PAGE G4-8	NOMENCLATURE PAGE G4-9	MODIFICATION/ACCESSORIES PAGE G4-90
--------------------------------	----------------------------	---------------------------	--

SELECTION/DIMENSIONS

DODGE®



TIGEAR-2 QUILL INPUT - SIZE 26

RATIO	OUTPUT RPM	RATING DATA 1750 INPUT RPM		PART NUMBER			SHAFT POSITION
				56C	140TC	180TC	
5	350	Mechanical Input Hp	7.37		26Q05L14	26Q05L18	L
		Thermal Input Hp	8.79		26Q05R14	26Q05R18	R
		Output Torque (lb in.)	1247		26Q05LR14	26Q05LR18	LR
		Mechanical Output Hp	6.93		26Q05H14	26Q05H18	HOLLOW
		Output OHL (lbs.)	1330		26Q05HA14	26Q05HA18	HOLLOW ALT.
7.5	233	Mechanical Input Hp	5.92	26Q07L56	26Q07L14	26Q07L18	L
		Thermal Input Hp	6.89	26Q07R56	26Q07R14	26Q07R18	R
		Output Torque (lb in.)	1458	26Q07LR56	26Q07LR14	26Q07LR18	LR
		Mechanical Output Hp	5.47	26Q07H56	26Q07H14	26Q07H18	HOLLOW
		Output OHL (lbs.)	1520	26Q07HA56	26Q07HA14	26Q07HA18	HOLLOW ALT.
10	175	Mechanical Input Hp	4.83	26Q10L56	26Q10L14	26Q10L18	L
		Thermal Input Hp	5.61	26Q10R56	26Q10R14	26Q10R18	R
		Output Torque (lb in.)	1576	26Q10LR56	26Q10LR14	26Q10LR18	LR
		Mechanical Output Hp	4.37	26Q10H56	26Q10H14	26Q10H18	HOLLOW
		Output OHL (lbs.)	1610	26Q10HA56	26Q10HA14	26Q10HA18	HOLLOW ALT.
12.7	138	Mechanical Input Hp	4.08	26Q12L56	26Q12L14	26Q12L18	L
		Thermal Input Hp	4.72	26Q12R56	26Q12R14	26Q12R18	R
		Output Torque (lb in.)	1654	26Q12LR56	26Q12LR14	26Q12LR18	LR
		Mechanical Output Hp	3.63	26Q12H56	26Q12H14	26Q12H18	HOLLOW
		Output OHL (lbs.)	1610	26Q12HA56	26Q12HA14	26Q12HA18	HOLLOW ALT.
15	117	Mechanical Input Hp	3.62	26Q15L56	26Q15L14	26Q15L18	L
		Thermal Input Hp	4.15	26Q15R56	26Q15R14	26Q15R18	R
		Output Torque (lb in.)	1708	26Q15LR56	26Q15LR14	26Q15LR18	LR
		Mechanical Output Hp	3.16	26Q15H56	26Q15H14	26Q15H18	HOLLOW
		Output OHL (lbs.)	1610	26Q15HA56	26Q15HA14	26Q15HA18	HOLLOW ALT.
18	97	Mechanical Input Hp	3.05	26Q15L56	26Q15L14	26Q15L18	L
		Thermal Input Hp	3.73	26Q15R56	26Q15R14	26Q15R18	R
		Output Torque (lb in.)	1708	26Q15LR56	26Q15LR14	26Q15LR18	LR
		Mechanical Output Hp	2.63	26Q15H56	26Q15H14	26Q15H18	HOLLOW
		Output OHL (lbs.)	1610	26Q15HA56	26Q15HA14	26Q15HA18	HOLLOW ALT.
20	88	Mechanical Input Hp	2.71	26Q20L56	26Q20L14	26Q20L18	L
		Thermal Input Hp	3.71	26Q20R56	26Q20R14	26Q20R18	R
		Output Torque (lb in.)	1673	26Q20LR56	26Q20LR14	26Q20LR18	LR
		Mechanical Output Hp	2.32	26Q20H56	26Q20H14	26Q20H18	HOLLOW
		Output OHL (lbs.)	1610	26Q20HA56	26Q20HA14	26Q20HA18	HOLLOW ALT.
25	70	Mechanical Input Hp	2.26	26Q25L56	26Q25L14	26Q25L18	L
		Thermal Input Hp	3.00	26Q25R56	26Q25R14	26Q25R18	R
		Output Torque (lb in.)	1677	26Q25LR56	26Q25LR14	26Q25LR18	LR
		Mechanical Output Hp	1.86	26Q25H56	26Q25H14	26Q25H18	HOLLOW
		Output OHL (lbs.)	1610	26Q25HA56	26Q25HA14	26Q25HA18	HOLLOW ALT.
30	58	Mechanical Input Hp	2.00	26Q30L56	26Q30L14	26Q30L18	L
		Thermal Input Hp	2.79	26Q30R56	26Q30R14	26Q30R18	R
		Output Torque (lb in.)	1705	26Q30LR56	26Q30LR14	26Q30LR18	LR
		Mechanical Output Hp	1.58	26Q30H56	26Q30H14	26Q30H18	HOLLOW
		Output OHL (lbs.)	1610	26Q30HA56	26Q30HA14	26Q30HA18	HOLLOW ALT.
40	44	Mechanical Input Hp	1.55	26Q40L56	26Q40L14	26Q40L18	L
		Thermal Input Hp	2.14	26Q40R56	26Q40R14	26Q40R18	R
		Output Torque (lb in.)	1685	26Q40LR56	26Q40LR14	26Q40LR18	LR
		Mechanical Output Hp	1.17	26Q40H56	26Q40H14	26Q40H18	HOLLOW
		Output OHL (lbs.)	1610	26Q40HA56	26Q40HA14	26Q40HA18	HOLLOW ALT.
50	35	Mechanical Input Hp	1.32	26Q50L56	26Q50L14	26Q50L18	L
		Thermal Input Hp	1.76	26Q50R56	26Q50R14	26Q50R18	R
		Output Torque (lb in.)	1662	26Q50LR56	26Q50LR14	26Q50LR18	LR
		Mechanical Output Hp	0.92	26Q50H56	26Q50H14	26Q50H18	HOLLOW
		Output OHL (lbs.)	1610	26Q50HA56	26Q50HA14	26Q50HA18	HOLLOW ALT.
60	29	Mechanical Input Hp	1.08	26Q60L56	26Q60L14	26Q60L18	L
		Thermal Input Hp	1.57	26Q60R56	26Q60R14	26Q60R18	R
		Output Torque (lb in.)	1547	26Q60LR56	26Q60LR14	26Q60LR18	LR
		Mechanical Output Hp	0.72	26Q60H56	26Q60H14	26Q60H18	HOLLOW
		Output OHL (lbs.)	1610	26Q60HA56	26Q60HA14	26Q60HA18	HOLLOW ALT.

Note: Reducers are shipped without a mounting base. Order bolt-on base kit **26BASE** if required.

Refer to page G4-96 for hollow bore bushing selections

FEATURES/BENEFITS PAGE G4-2	SPECIFICATION PAGE G4-8	NOMENCLATURE PAGE G4-9	MODIFICATION/ACCESSORIES PAGE G4-90
--------------------------------	----------------------------	---------------------------	--

SELECTION/DIMENSIONS



TIGEAR-2 QUILL INPUT - SIZE 26

SOLID OUTPUT

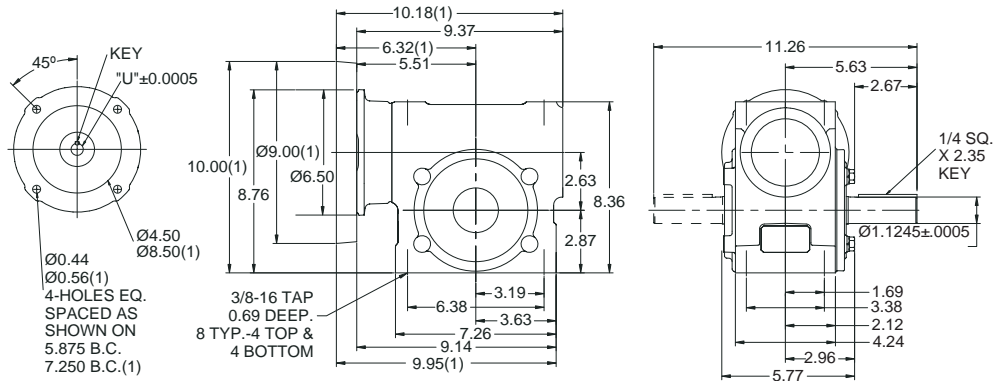

(1) DIMENSIONS APPLY TO 180 FRAME MOTOR ADAPTER

HOLLOW OUTPUT

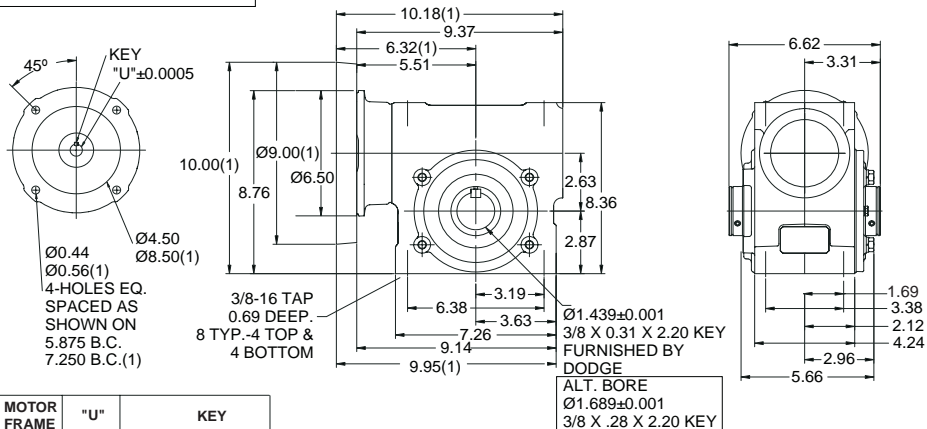

MOTOR FRAME	"U"	KEY
48Y 56C	.626	3/16 SQ. x 1.50 KEY
140TC 160ATC	.876	3/16 SQ x 1.50 KEY
180TC 180ATC	1.126	1/4 SQ x 2.00 KEY

OUTPUT SHAFT CONFIGURATIONS

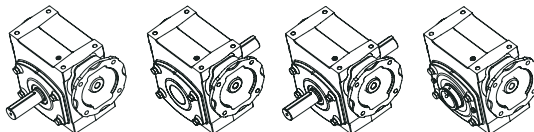

L

R

LR

H or HA

FEATURES/BENEFITS
PAGE G4-2

SPECIFICATION
PAGE G4-8

NOMENCLATURE
PAGE G4-9

MODIFICATION/ACCESSORIES
PAGE G4-90



SELECTION/DIMENSIONS

TIGEAR-2 SEPARATE INPUT - SIZE 26

RATIO	OUTPUT RPM	RATING DATA 1750 INPUT RPM		SEPARATE REDUCER	SHAFT POSITION	OPTIONAL MOTOR ADAPTER KIT		
						56C	140TC	180TC
5	350	Mechanical Input Hp	7.37	26S05L	L	2330MTR14	2330MTR18	
		Thermal Input Hp	8.79	26S05R	R			
		Output Torque (lb in.)	1247	26S05LR	LR			
		Mechanical Output Hp	6.93	26S05H	HOLLOW			
		Output OHL (lbs.)	1330	26S05HA	HOLLOW ALT.			
7.5	233	Mechanical Input Hp	5.92	26S07L	L	2330MTR56	2330MTR14	2330MTR18
		Thermal Input Hp	6.89	26S07R	R			
		Output Torque (lb in.)	1458	26S07LR	LR			
		Mechanical Output Hp	5.47	26S07H	HOLLOW			
		Output OHL (lbs.)	1520	26S07HA	HOLLOW ALT.			
10	175	Mechanical Input Hp	4.83	26S10L	L	2330MTR56	2330MTR14	2330MTR18
		Thermal Input Hp	5.61	26S10R	R			
		Output Torque (lb in.)	1576	26S10LR	LR			
		Mechanical Output Hp	4.37	26S10H	HOLLOW			
		Output OHL (lbs.)	1610	26S10HA	HOLLOW ALT.			
12.7	138	Mechanical Input Hp	4.08	26S12L	L	2330MTR56	2330MTR14	2330MTR18
		Thermal Input Hp	4.72	26S12R	R			
		Output Torque (lb in.)	1654	26S12LR	LR			
		Mechanical Output Hp	3.63	26S12H	HOLLOW			
		Output OHL (lbs.)	1610	26S12HA	HOLLOW ALT.			
15	117	Mechanical Input Hp	3.62	26S15L	L	2330MTR56	2330MTR14	2330MTR18
		Thermal Input Hp	4.15	26S15R	R			
		Output Torque (lb in.)	1708	26S15LR	LR			
		Mechanical Output Hp	3.16	26S15H	HOLLOW			
		Output OHL (lbs.)	1610	26S15HA	HOLLOW ALT.			
18	97	Mechanical Input Hp	3.05	26S18L	L	2330MTR56	2330MTR14	
		Thermal Input Hp	3.73	26S18R	R			
		Output Torque (lb in.)	1708	26S18LR	LR			
		Mechanical Output Hp	2.63	26S18H	HOLLOW			
		Output OHL (lbs.)	1610	26S18HA	HOLLOW ALT.			
20	88	Mechanical Input Hp	2.71	26S20L	L	2330MTR56	2330MTR14	
		Thermal Input Hp	3.71	26S20R	R			
		Output Torque (lb in.)	1673	26S20LR	LR			
		Mechanical Output Hp	2.32	26S20H	HOLLOW			
		Output OHL (lbs.)	1610	26S20HA	HOLLOW ALT.			
25	70	Mechanical Input Hp	2.26	26S25L	L	2330MTR56	2330MTR14	
		Thermal Input Hp	3.00	26S25R	R			
		Output Torque (lb in.)	1677	26S25LR	LR			
		Mechanical Output Hp	1.86	26S25H	HOLLOW			
		Output OHL (lbs.)	1610	26S25HA	HOLLOW ALT.			
30	58	Mechanical Input Hp	2.00	26S30L	L	2330MTR56	2330MTR14	
		Thermal Input Hp	2.79	26S30R	R			
		Output Torque (lb in.)	1705	26S30LR	LR			
		Mechanical Output Hp	1.58	26S30H	HOLLOW			
		Output OHL (lbs.)	1610	26S30HA	HOLLOW ALT.			
40	44	Mechanical Input Hp	1.55	26S40L	L	2330MTR56	2330MTR14	
		Thermal Input Hp	2.14	26S40R	R			
		Output Torque (lb in.)	1685	26S40LR	LR			
		Mechanical Output Hp	1.17	26S40H	HOLLOW			
		Output OHL (lbs.)	1610	26S40HA	HOLLOW ALT.			
50	35	Mechanical Input Hp	1.32	26S50L	L	2330MTR56	2330MTR14	
		Thermal Input Hp	1.76	26S50R	R			
		Output Torque (lb in.)	1662	26S50LR	LR			
		Mechanical Output Hp	0.92	26S50H	HOLLOW			
		Output OHL (lbs.)	1610	26S50HA	HOLLOW ALT.			
60	29	Mechanical Input Hp	1.08	26S60L	L	2330MTR56	2330MTR14	
		Thermal Input Hp	1.57	26S60R	R			
		Output Torque (lb in.)	1547	26S60LR	LR			
		Mechanical Output Hp	0.72	26S60H	HOLLOW			
		Output OHL (lbs.)	1610	26S60HA	HOLLOW ALT.			
All Ratios		Input OHL (lbs)	250	One diameter from seal surface				

Note: TIGEAR-2 separate reducers cannot be used with the old Adaptable TIGEAR motor adapter kits.

Refer to page G4-96 for hollow bore bushing selections

SELECTION/DIMENSIONS



TIGEAR-2 SEPARATE INPUT - SIZE 26

SOLID OUTPUT

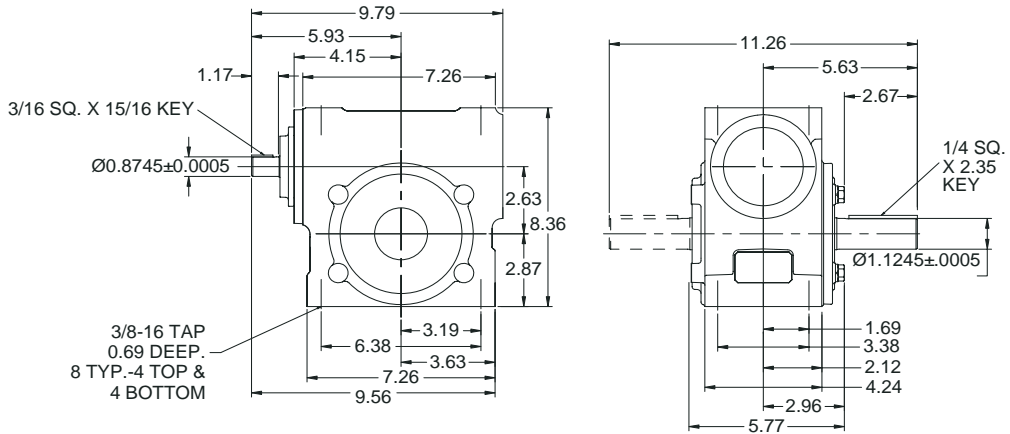

HOLLOW OUTPUT

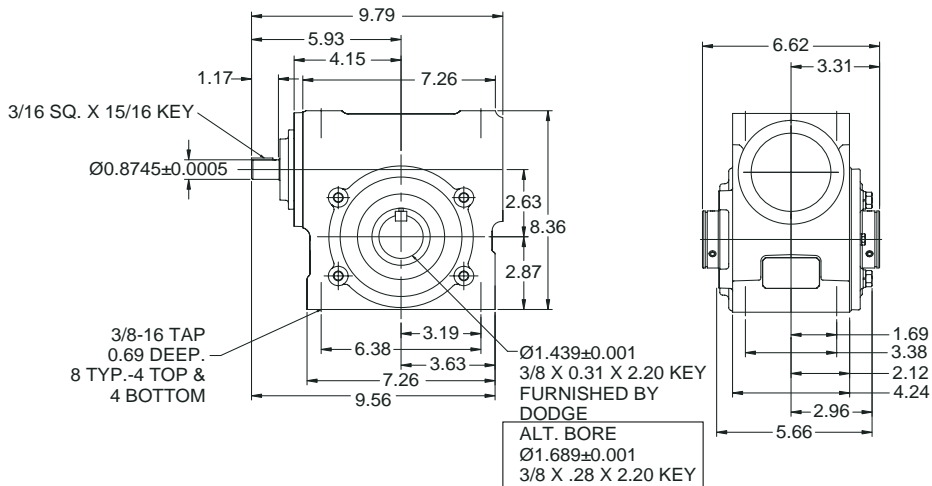

OUTPUT SHAFT CONFIGURATIONS

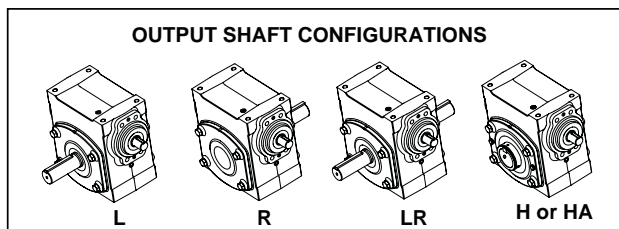

FEATURES/BENEFITS PAGE G4-2	SPECIFICATION PAGE G4-8	NOMENCLATURE PAGE G4-9	MODIFICATION/ACCESSORIES PAGE G4-90
--------------------------------	----------------------------	---------------------------	--

SELECTION/DIMENSIONS



TIGEAR-2 COUPLED INPUT - ADAPTER ASSEMBLY - SIZE 26

Coupled input units include a Separate reducer and motor adapter kit assembled together.

These assemblies are normally "made to order" with a 5 day standard lead time.

RATIO	OUTPUT RPM	RATING DATA 1750 INPUT RPM		PART NUMBER			SHAFT POSITION
				56C	140TC	180TC	
5	350	Mechanical Input Hp	7.37		26A05L14	26A05L18	L
		Thermal Input Hp	8.79		26A05R14	26A05R18	R
		Output Torque (lb in.)	1247		26A05LR14	26A05LR18	LR
		Mechanical Output Hp	6.93		26A05H14	26A05H18	HOLLOW
		Output OHL (lbs.)	1330		26A05HA14	26A05HA18	HOLLOW ALT.
7.5	233	Mechanical Input Hp	5.92	26A07L56	26A07L14	26A07L18	L
		Thermal Input Hp	6.89	26A07R56	26A07R14	26A07R18	R
		Output Torque (lb in.)	1458	26A07LR56	26A07LR14	26A07LR18	LR
		Mechanical Output Hp	5.47	26A07H56	26A07H14	26A07H18	HOLLOW
		Output OHL (lbs.)	1520	26A07HA56	26A07HA14	26A07HA18	HOLLOW ALT.
10	175	Mechanical Input Hp	4.83	26A10L56	26A10L14	26A10L18	L
		Thermal Input Hp	5.61	26A10R56	26A10R14	26A10R18	R
		Output Torque (lb in.)	1576	26A10LR56	26A10LR14	26A10LR18	LR
		Mechanical Output Hp	4.37	26A10H56	26A10H14	26A10H18	HOLLOW
		Output OHL (lbs.)	1610	26A10HA56	26A10HA14	26A10HA18	HOLLOW ALT.
12.7	138	Mechanical Input Hp	4.08	26A12L56	26A12L14	26A12L18	L
		Thermal Input Hp	4.72	26A12R56	26A12R14	26A12R18	R
		Output Torque (lb in.)	1654	26A12LR56	26A12LR14	26A12LR18	LR
		Mechanical Output Hp	3.63	26A12H56	26A12H14	26A12H18	HOLLOW
		Output OHL (lbs.)	1610	26A12HA56	26A12HA14	26A12HA18	HOLLOW ALT.
15	117	Mechanical Input Hp	3.62	26A15L56	26A15L14	26A15L18	L
		Thermal Input Hp	4.15	26A15R56	26A15R14	26A15R18	R
		Output Torque (lb in.)	1708	26A15LR56	26A15LR14	26A15LR18	LR
		Mechanical Output Hp	3.16	26A15H56	26A15H14	26A15H18	HOLLOW
		Output OHL (lbs.)	1610	26A15HA56	26A15HA14	26A15HA18	HOLLOW ALT.
18	97	Mechanical Input Hp	3.05	26A18L56	26A18L14	26A18L18	L
		Thermal Input Hp	3.73	26A18R56	26A18R14	26A18R18	R
		Output Torque (lb in.)	1708	26A18LR56	26A18LR14	26A18LR18	LR
		Mechanical Output Hp	2.63	26A18H56	26A18H14	26A18H18	HOLLOW
		Output OHL (lbs.)	1610	26A18HA56	26A18HA14	26A18HA18	HOLLOW ALT.
20	88	Mechanical Input Hp	2.71	26A20L56	26A20L14	26A20L18	L
		Thermal Input Hp	3.71	26A20R56	26A20R14	26A20R18	R
		Output Torque (lb in.)	1673	26A20LR56	26A20LR14	26A20LR18	LR
		Mechanical Output Hp	2.32	26A20H56	26A20H14	26A20H18	HOLLOW
		Output OHL (lbs.)	1610	26A20HA56	26A20HA14	26A20HA18	HOLLOW ALT.
25	70	Mechanical Input Hp	2.26	26A25L56	26A25L14	26A25L18	L
		Thermal Input Hp	3.00	26A25R56	26A25R14	26A25R18	R
		Output Torque (lb in.)	1677	26A25LR56	26A25LR14	26A25LR18	LR
		Mechanical Output Hp	1.86	26A25H56	26A25H14	26A25H18	HOLLOW
		Output OHL (lbs.)	1610	26A25HA56	26A25HA14	26A25HA18	HOLLOW ALT.
30	58	Mechanical Input Hp	2.00	26A30L56	26A30L14	26A30L18	L
		Thermal Input Hp	2.79	26A30R56	26A30R14	26A30R18	R
		Output Torque (lb in.)	1705	26A30LR56	26A30LR14	26A30LR18	LR
		Mechanical Output Hp	1.58	26A30H56	26A30H14	26A30H18	HOLLOW
		Output OHL (lbs.)	1610	26A30HA56	26A30HA14	26A30HA18	HOLLOW ALT.
40	44	Mechanical Input Hp	1.55	26A40L56	26A40L14	26A40L18	L
		Thermal Input Hp	2.14	26A40R56	26A40R14	26A40R18	R
		Output Torque (lb in.)	1685	26A40LR56	26A40LR14	26A40LR18	LR
		Mechanical Output Hp	1.17	26A40H56	26A40H14	26A40H18	HOLLOW
		Output OHL (lbs.)	1610	26A40HA56	26A40HA14	26A40HA18	HOLLOW ALT.
50	35	Mechanical Input Hp	1.32	26A50L56	26A50L14	26A50L18	L
		Thermal Input Hp	1.76	26A50R56	26A50R14	26A50R18	R
		Output Torque (lb in.)	1662	26A50LR56	26A50LR14	26A50LR18	LR
		Mechanical Output Hp	0.92	26A50H56	26A50H14	26A50H18	HOLLOW
		Output OHL (lbs.)	1610	26A50HA56	26A50HA14	26A50HA18	HOLLOW ALT.
60	29	Mechanical Input Hp	1.08	26A60L56	26A60L14	26A60L18	L
		Thermal Input Hp	1.57	26A60R56	26A60R14	26A60R18	R
		Output Torque (lb in.)	1547	26A60LR56	26A60LR14	26A60LR18	LR
		Mechanical Output Hp	0.72	26A60H56	26A60H14	26A60H18	HOLLOW
		Output OHL (lbs.)	1610	26A60HA56	26A60HA14	26A60HA18	HOLLOW ALT.

Note: Reducers are shipped without a mounting base. Order bolt-on base kit **26BASE** if required.

Refer to page G4-96 for hollow bore bushing selections

FEATURES/BENEFITS PAGE G4-2	SPECIFICATION PAGE G4-8	NOMENCLATURE PAGE G4-9	MODIFICATION/ACCESSORIES PAGE G4-90
--------------------------------	----------------------------	---------------------------	--

SELECTION/DIMENSIONS



TIGEAR-2 COUPLED INPUT - SIZE 26

SOLID OUTPUT

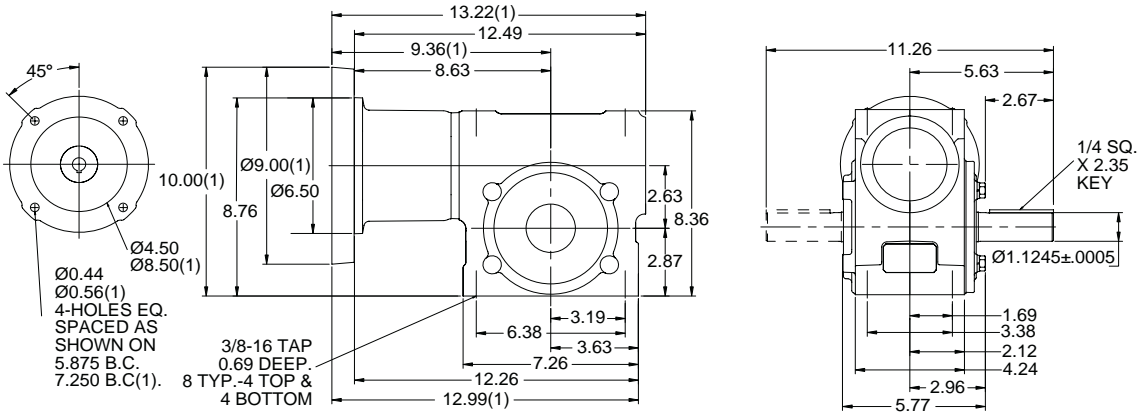

(1) DIMENSIONS APPLY TO 180 FRAME MOTOR ADAPTER

HOLLOW OUTPUT

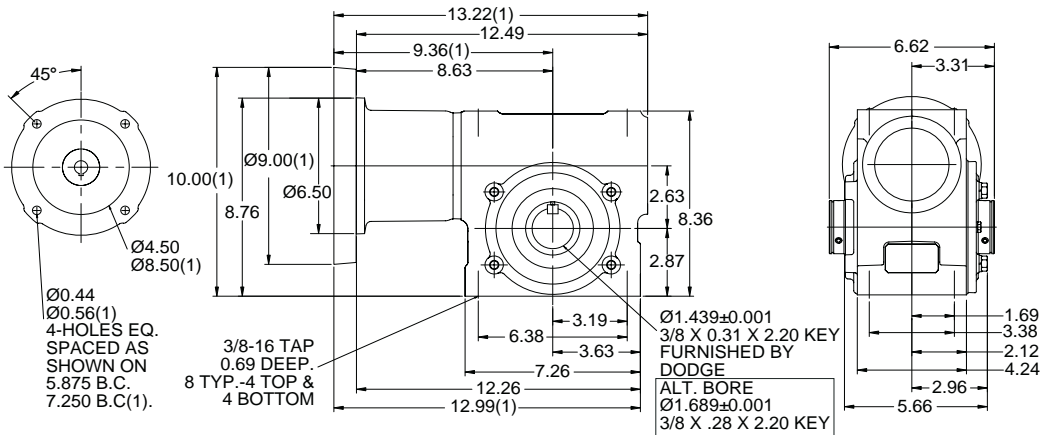

ALT. BORE
Ø1.689±0.001
3/8 X .28 X 2.20 KEY

OUTPUT SHAFT CONFIGURATIONS

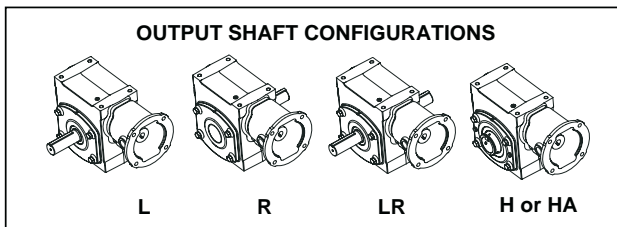

FEATURES/BENEFITS PAGE G4-2	SPECIFICATION PAGE G4-8	NOMENCLATURE PAGE G4-9	MODIFICATION/ACCESSORIES PAGE G4-90
--------------------------------	----------------------------	---------------------------	--

SELECTION/DIMENSIONS

DODGE®



TIGEAR-2 QUILL INPUT - SIZE 30

RATIO	OUTPUT RPM	RATING DATA		PART NUMBER			SHAFT POSITION
		1750 INPUT RPM		56C	140TC	180TC	
5	350	Mechanical Input Hp	10.84		30Q05L14	30Q05L18	L
		Thermal Input Hp	12.53		30Q05R14	30Q05R18	R
		Output Torque (lb in.)	1849		30Q05LR14	30Q05LR18	LR
		Mechanical Output Hp	10.27		30Q05H14	30Q05H18	HOLLOW
		Output OHL (lbs.)	1330				
7.5	233	Mechanical Input Hp	8.74		30Q07L14	30Q07L18	L
		Thermal Input Hp	9.64		30Q07R14	30Q07R18	R
		Output Torque (lb in.)	2171		30Q07LR14	30Q07LR18	LR
		Mechanical Output Hp	8.15		30Q07H14	30Q07H18	HOLLOW
		Output OHL (lbs.)	1540				
10	175	Mechanical Input Hp	7.11		30Q10L14	30Q10L18	L
		Thermal Input Hp	7.85		30Q10R14	30Q10R18	R
		Output Torque (lb in.)	2347		30Q10LR14	30Q10LR18	LR
		Mechanical Output Hp	6.52		30Q10H14	30Q10H18	HOLLOW
		Output OHL (lbs.)	1720				
15	117	Mechanical Input Hp	5.00		30Q15L14	30Q15L18	L
		Thermal Input Hp	5.72		30Q15R14	30Q15R18	R
		Output Torque (lb in.)	2371		30Q15LR14	30Q15LR18	LR
		Mechanical Output Hp	4.39		30Q15H14	30Q15H18	HOLLOW
		Output OHL (lbs.)	2300				
20	88	Mechanical Input Hp	3.81	30Q20L56	30Q20L14	30Q20L18	L
		Thermal Input Hp	4.52	30Q20R56	30Q20R14	30Q20R18	R
		Output Torque (lb in.)	2345	30Q20LR56	30Q20LR14	30Q20LR18	LR
		Mechanical Output Hp	3.26	30Q20H56	30Q20H14	30Q20H18	HOLLOW
		Output OHL (lbs.)	2300				
25	70	Mechanical Input Hp	3.05	30Q25L56	30Q25L14	30Q25L18	L
		Thermal Input Hp	3.90	30Q25R56	30Q25R14	30Q25R18	R
		Output Torque (lb in.)	2284	30Q25LR56	30Q25LR14	30Q25LR18	LR
		Mechanical Output Hp	2.54	30Q25H56	30Q25H14	30Q25H18	HOLLOW
		Output OHL (lbs.)	2300				
30	58	Mechanical Input Hp	2.75	30Q30L56	30Q30L14		L
		Thermal Input Hp	3.58	30Q30R56	30Q30R14		R
		Output Torque (lb in.)	2417	30Q30LR56	30Q30LR14		LR
		Mechanical Output Hp	2.24	30Q30H56	30Q30H14		HOLLOW
		Output OHL (lbs.)	2300				
40	44	Mechanical Input Hp	2.09	30Q40L56	30Q40L14		L
		Thermal Input Hp	2.87	30Q40R56	30Q40R14		R
		Output Torque (lb in.)	2324	30Q40LR56	30Q40LR14		LR
		Mechanical Output Hp	1.61	30Q40H56	30Q40H14		HOLLOW
		Output OHL (lbs.)	2300				
50	35	Mechanical Input Hp	1.75	30Q50L56	30Q50L14		L
		Thermal Input Hp	2.34	30Q50R56	30Q50R14		R
		Output Torque (lb in.)	2257	30Q50LR56	30Q50LR14		LR
		Mechanical Output Hp	1.25	30Q50H56	30Q50H14		HOLLOW
		Output OHL (lbs.)	2300				
60	29	Mechanical Input Hp	1.50	30Q60L56	30Q60L14		L
		Thermal Input Hp	2.01	30Q60R56	30Q60R14		R
		Output Torque (lb in.)	2138	30Q60LR56	30Q60LR14		LR
		Mechanical Output Hp	0.99	30Q60H56	30Q60H14		HOLLOW
		Output OHL (lbs.)	2300				

Note: Reducers are shipped without a mounting base. Order bolt-on base kit **30BASE** if required.

FEATURES/BENEFITS PAGE G4-2	SPECIFICATION PAGE G4-8	NOMENCLATURE PAGE G4-9	MODIFICATION/ACCESSORIES PAGE G4-90
--------------------------------	----------------------------	---------------------------	--

SELECTION/DIMENSIONS



TIGEAR-2 QUILL INPUT - SIZE 30

SOLID OUTPUT

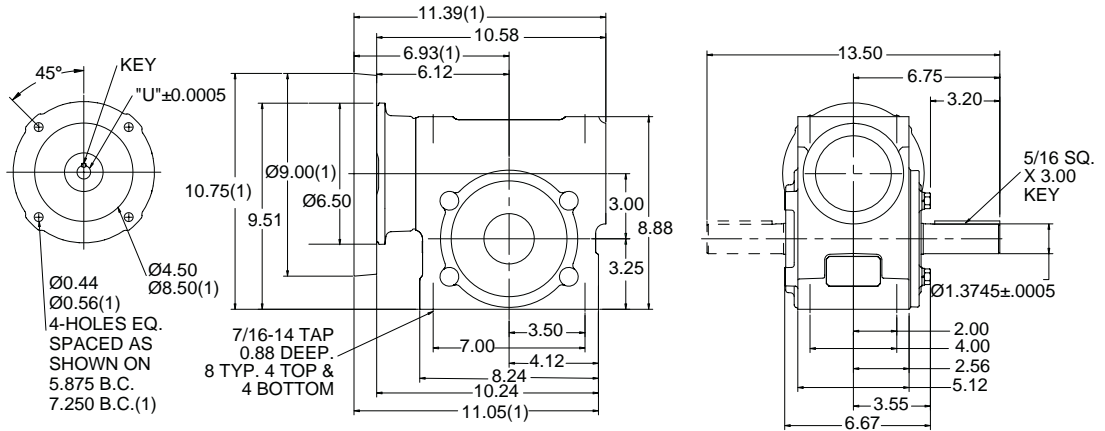

(1) DIMENSIONS APPLY TO 180 FRAME MOTOR ADAPTER

HOLLOW OUTPUT

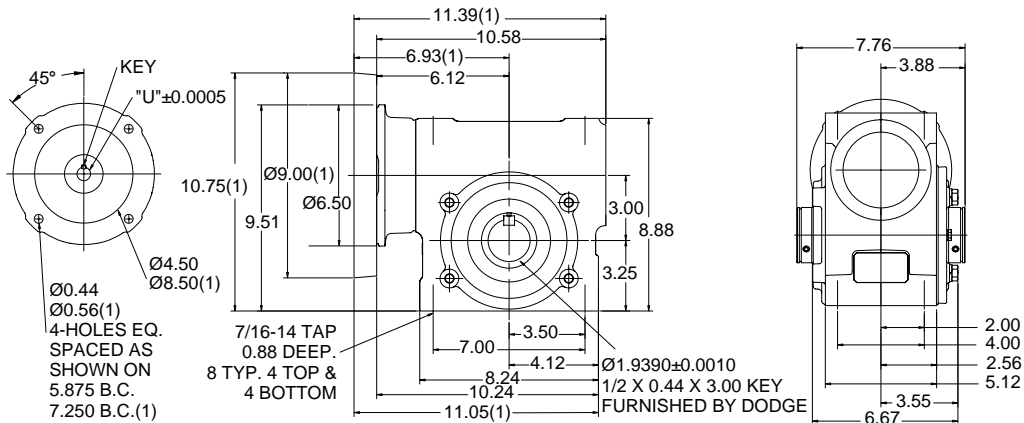

MOTOR FRAME	"U"	KEY
48Y 56C	.626	3/16 SQ. X 1.50 KEY
140TC 160ATC	.876	3/16 SQ. X 1.50 KEY
180TC 180ATC	1.126	1/4 SQ. X 2.00 KEY

OUTPUT SHAFT CONFIGURATIONS

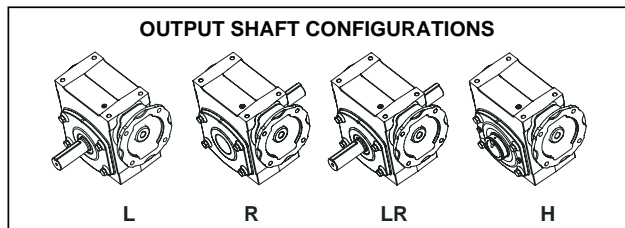

FEATURES/BENEFITS PAGE G4-2	SPECIFICATION PAGE G4-8	NOMENCLATURE PAGE G4-9	MODIFICATION/ACCESSORIES PAGE G4-90
--------------------------------	----------------------------	---------------------------	--



SELECTION/DIMENSIONS

TIGEAR-2 SEPARATE INPUT - SIZE 30

RATIO	OUTPUT RPM	RATING DATA 1750 INPUT RPM		SEPARATE REDUCER	SHAFT POSITION	OPTIONAL MOTOR ADAPTER KIT		
						56C	140TC	180TC
5	350	Mechanical Input Hp	10.84	30S05L	L	2330MTR14	2330MTR18	
		Thermal Input Hp	12.53	30S05R	R			
		Output Torque (lb in.)	1849	30S05LR	LR			
		Mechanical Output Hp	10.27	30S05H	HOLLOW			
		Output OHL (lbs.)	1330					
7.5	233	Mechanical Input Hp	8.74	30S07L	L	2330MTR14	2330MTR18	
		Thermal Input Hp	9.64	30S07R	R			
		Output Torque (lb in.)	2171	30S07LR	LR			
		Mechanical Output Hp	8.15	30S07H	HOLLOW			
		Output OHL (lbs.)	1540					
10	175	Mechanical Input Hp	7.11	30S10L	L	2330MTR14	2330MTR18	
		Thermal Input Hp	7.85	30S10R	R			
		Output Torque (lb in.)	2347	30S10LR	LR			
		Mechanical Output Hp	6.52	30S10H	HOLLOW			
		Output OHL (lbs.)	1720					
15	117	Mechanical Input Hp	5.00	30S15L	L	2330MTR14	2330MTR18	
		Thermal Input Hp	5.72	30S15R	R			
		Output Torque (lb in.)	2371	30S15LR	LR			
		Mechanical Output Hp	4.39	30S15H	HOLLOW			
		Output OHL (lbs.)	2300					
20	88	Mechanical Input Hp	3.81	30S20L	L	2330MTR56	2330MTR14	2330MTR18
		Thermal Input Hp	4.52	30S20R	R			
		Output Torque (lb in.)	2345	30S20LR	LR			
		Mechanical Output Hp	3.26	30S20H	HOLLOW			
		Output OHL (lbs.)	2300					
25	70	Mechanical Input Hp	3.05	30S25L	L	2330MTR56	2330MTR14	2330MTR18
		Thermal Input Hp	3.90	30S25R	R			
		Output Torque (lb in.)	2284	30S25LR	LR			
		Mechanical Output Hp	2.54	30S25H	HOLLOW			
		Output OHL (lbs.)	2300					
30	58	Mechanical Input Hp	2.75	30S30L	L	2330MTR56	2330MTR14	
		Thermal Input Hp	3.58	30S30R	R			
		Output Torque (lb in.)	2417	30S30LR	LR			
		Mechanical Output Hp	2.24	30S30H	HOLLOW			
		Output OHL (lbs.)	2300					
40	44	Mechanical Input Hp	2.09	30S40L	L	2330MTR56	2330MTR14	
		Thermal Input Hp	2.87	30S40R	R			
		Output Torque (lb in.)	2324	30S40LR	LR			
		Mechanical Output Hp	1.61	30S40H	HOLLOW			
		Output OHL (lbs.)	2300					
50	35	Mechanical Input Hp	1.75	30S50L	L	2330MTR56	2330MTR14	
		Thermal Input Hp	2.34	30S50R	R			
		Output Torque (lb in.)	2257	30S50LR	LR			
		Mechanical Output Hp	1.25	30S50H	HOLLOW			
		Output OHL (lbs.)	2300					
60	29	Mechanical Input Hp	1.50	30S60L	L	2330MTR56	2330MTR14	
		Thermal Input Hp	2.01	30S60R	R			
		Output Torque (lb in.)	2138	30S60LR	LR			
		Mechanical Output Hp	0.99	30S60H	HOLLOW			
		Output OHL (lbs.)	2300					
All Ratios		Input OHL (lbs)	280	One diameter from seal surface				

Note: TIGEAR-2 separate reducers cannot be used with the old Adaptable TIGEAR motor adapter kits.

FEATURES/BENEFITS PAGE G4-2	SPECIFICATION PAGE G4-8	NOMENCLATURE PAGE G4-9	MODIFICATION/ACCESSORIES PAGE G4-90
--------------------------------	----------------------------	---------------------------	--

SELECTION/DIMENSIONS



TIGEAR-2 SEPARATE INPUT - SIZE 30

SOLID OUTPUT

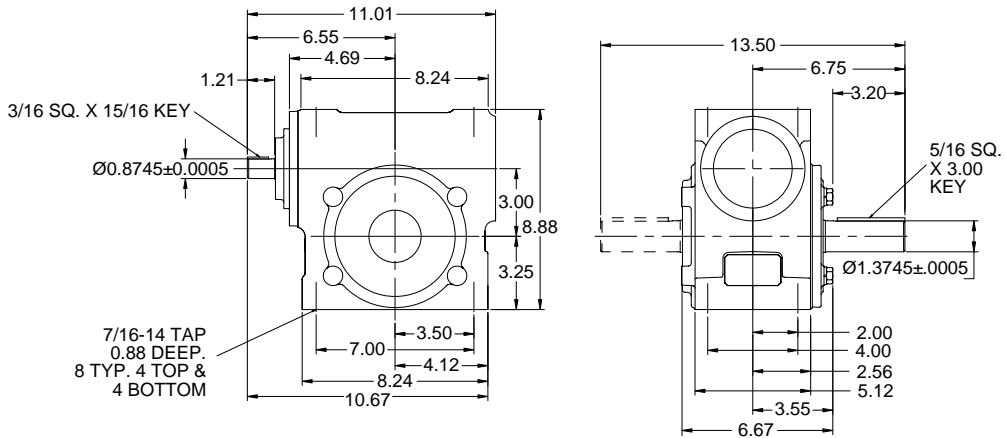

HOLLOW OUTPUT

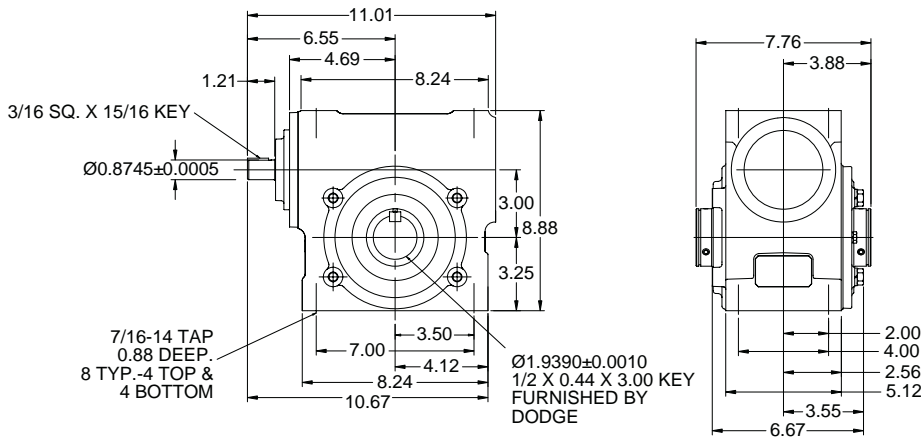

OUTPUT SHAFT CONFIGURATIONS

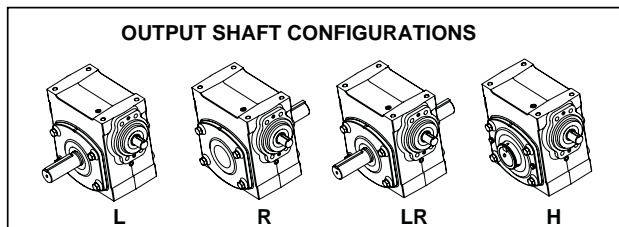



SELECTION/DIMENSIONS

TIGEAR-2 COUPLED INPUT - ADAPTER ASSEMBLY - SIZE 30

Coupled input units include a Separate reducer and motor adapter kit assembled together.

These assemblies are normally "made to order" with a 5 day standard lead time.

RATIO	OUTPUT RPM	RATING DATA 1750 INPUT RPM		PART NUMBER			SHAFT POSITION
				56C	140TC	180TC	
5	350	Mechanical Input Hp	10.84		30A05L14	30A05L18	L
		Thermal Input Hp	12.53		30A05R14	30A05R18	R
		Output Torque (lb in.)	1849		30A05LR14	30A05LR18	LR
		Mechanical Output Hp	10.27		30A05H14	30A05H18	HOLLOW
		Output OHL (lbs.)	1330				
7.5	233	Mechanical Input Hp	8.74		30A07L14	30A07L18	L
		Thermal Input Hp	9.64		30A07R14	30A07R18	R
		Output Torque (lb in.)	2171		30A07LR14	30A07LR18	LR
		Mechanical Output Hp	8.15		30A07H14	30A07H18	HOLLOW
		Output OHL (lbs.)	1540				
10	175	Mechanical Input Hp	7.11		30A10L14	30A10L18	L
		Thermal Input Hp	7.85		30A10R14	30A10R18	R
		Output Torque (lb in.)	2347		30A10LR14	30A10LR18	LR
		Mechanical Output Hp	6.52		30A10H14	30A10H18	HOLLOW
		Output OHL (lbs.)	1720				
15	117	Mechanical Input Hp	5.00		30A15L14	30A15L18	L
		Thermal Input Hp	5.72		30A15R14	30A15R18	R
		Output Torque (lb in.)	2371		30A15LR14	30A15LR18	LR
		Mechanical Output Hp	4.39		30A15H14	30A15H18	HOLLOW
		Output OHL (lbs.)	2300				
20	88	Mechanical Input Hp	3.81	30A20L56	30A20L14	30A20L18	L
		Thermal Input Hp	4.52	30A20R56	30A20R14	30A20R18	R
		Output Torque (lb in.)	2345	30A20LR56	30A20LR14	30A20LR18	LR
		Mechanical Output Hp	3.26	30A20H56	30A20H14	30A20H18	HOLLOW
		Output OHL (lbs.)	2300				
25	70	Mechanical Input Hp	3.05	30A25L56	30A25L14	30A25L18	L
		Thermal Input Hp	3.90	30A25R56	30A25R14	30A25R18	R
		Output Torque (lb in.)	2284	30A25LR56	30A25LR14	30A25LR18	LR
		Mechanical Output Hp	2.54	30A25H56	30A25H14	30A25H18	HOLLOW
		Output OHL (lbs.)	2300				
30	58	Mechanical Input Hp	2.75	30A30L56	30A30L14		L
		Thermal Input Hp	3.58	30A30R56	30A30R14		R
		Output Torque (lb in.)	2417	30A30LR56	30A30LR14		LR
		Mechanical Output Hp	2.24	30A30H56	30A30H14		HOLLOW
		Output OHL (lbs.)	2300				
40	44	Mechanical Input Hp	2.09	30A40L56	30A40L14		L
		Thermal Input Hp	2.87	30A40R56	30A40R14		R
		Output Torque (lb in.)	2324	30A40LR56	30A40LR14		LR
		Mechanical Output Hp	1.61	30A40H56	30A40H14		HOLLOW
		Output OHL (lbs.)	2300				
50	35	Mechanical Input Hp	1.75	30A50L56	30A50L14		L
		Thermal Input Hp	2.34	30A50R56	30A50R14		R
		Output Torque (lb in.)	2257	30A50LR56	30A50LR14		LR
		Mechanical Output Hp	1.25	30A50H56	30A50H14		HOLLOW
		Output OHL (lbs.)	2300				
60	29	Mechanical Input Hp	1.50	30A60L56	30A60L14		L
		Thermal Input Hp	2.01	30A60R56	30A60R14		R
		Output Torque (lb in.)	2138	30A60LR56	30A60LR14		LR
		Mechanical Output Hp	0.99	30A60H56	30A60H14		HOLLOW
		Output OHL (lbs.)	2300				

Note: Reducers are shipped without a mounting base. Order bolt-on base kit **30BASE** if required.

FEATURES/BENEFITS PAGE G4-2	SPECIFICATION PAGE G4-8	NOMENCLATURE PAGE G4-9	MODIFICATION/ACCESSORIES PAGE G4-90
--------------------------------	----------------------------	---------------------------	--

SELECTION/DIMENSIONS



TIGEAR-2 COUPLED INPUT - SIZE 30

SOLID OUTPUT

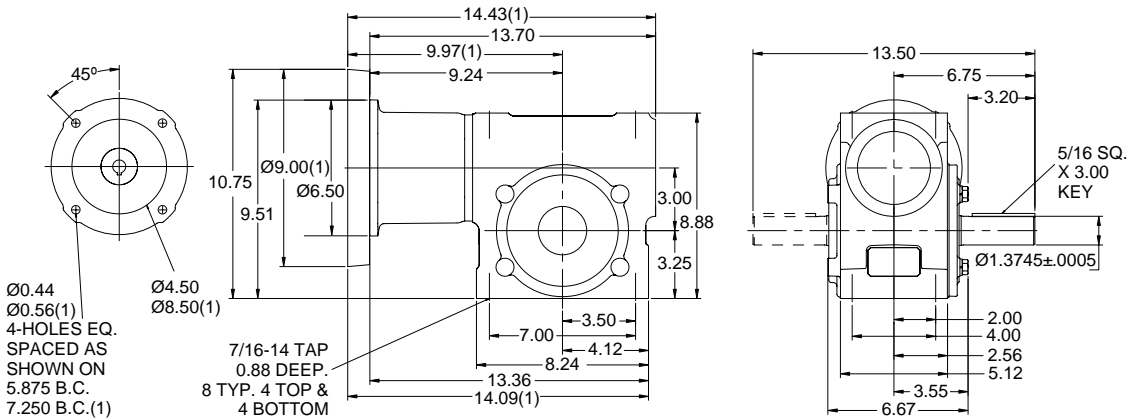

(1) DIMENSIONS APPLY TO 180 FRAME MOTOR ADAPTER

HOLLOW OUTPUT

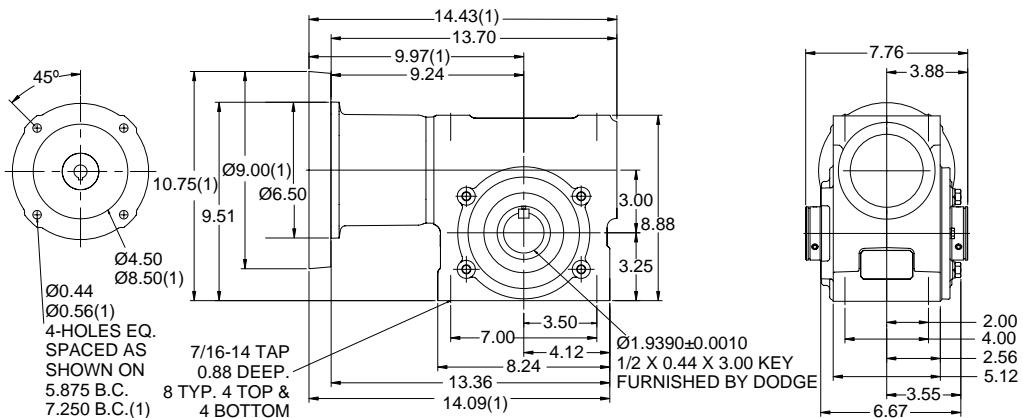

OUTPUT SHAFT CONFIGURATIONS

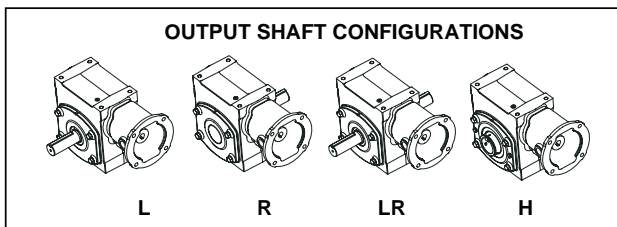

FEATURES/BENEFITS PAGE G4-2	SPECIFICATION PAGE G4-8	NOMENCLATURE PAGE G4-9	MODIFICATION/ACCESSORIES PAGE G4-90
--------------------------------	----------------------------	---------------------------	--

SELECTION/DIMENSIONS

DODGE®



TIGEAR-2 QUILL INPUT - SIZE 35

RATIO	OUTPUT RPM	RATING DATA 1750 INPUT RPM		PART NUMBER				SHAFT POSITION
				56C	140TC	180TC	210TC	
5	350	Mechanical Input Hp	15.18		35Q05L14	35Q05L18	35Q05L21	L
		Thermal Input Hp	15.51		35Q05R14	35Q05R18	35Q05R21	R
		Output Torque (lb in.)	2593		35Q05LR14	35Q05LR18	35Q05LR21	LR
		Mechanical Output Hp	14.40		35Q05H14	35Q05H18	35Q05H21	HOLLOW
		Output OHL (lbs.)	2120					
7.5	233	Mechanical Input Hp	12.24		35Q07L14	35Q07L18	35Q07L21	L
		Thermal Input Hp	12.52		35Q07R14	35Q07R18	35Q07R21	R
		Output Torque (lb in.)	3054		35Q07LR14	35Q07LR18	35Q07LR21	LR
		Mechanical Output Hp	11.46		35Q07H14	35Q07H18	35Q07H21	HOLLOW
		Output OHL (lbs.)	2430					
10	175	Mechanical Input Hp	10.00		35Q10L14	35Q10L18	35Q10L21	L
		Thermal Input Hp	10.63		35Q10R14	35Q10R18	35Q10R21	R
		Output Torque (lb in.)	3310		35Q10LR14	35Q10LR18	35Q10LR21	LR
		Mechanical Output Hp	9.19		35Q10H14	35Q10H18	35Q10H21	HOLLOW
		Output OHL (lbs.)	2700					
12.7	138	Mechanical Input Hp	8.51		35Q12L14	35Q12L18	35Q12L21	L
		Thermal Input Hp	8.75		35Q12R14	35Q12R18	35Q12R21	R
		Output Torque (lb in.)	3530		35Q12LR14	35Q12LR18	35Q12LR21	LR
		Mechanical Output Hp	7.74		35Q12H14	35Q12H18	35Q12H21	HOLLOW
		Output OHL (lbs.)	2760					
15	117	Mechanical Input Hp	7.44		35Q15L14	35Q15L18		L
		Thermal Input Hp	7.56		35Q15R14	35Q15R18		R
		Output Torque (lb in.)	3599		35Q15LR14	35Q15LR18		LR
		Mechanical Output Hp	6.66		35Q15H14	35Q15H18		HOLLOW
		Output OHL (lbs.)	2760					
20	88	Mechanical Input Hp	5.79		35Q20L14	35Q20L18		L
		Thermal Input Hp	5.97		35Q20R14	35Q20R18		R
		Output Torque (lb in.)	3620		35Q20LR14	35Q20LR18		LR
		Mechanical Output Hp	5.03		35Q20H14	35Q20H18		HOLLOW
		Output OHL (lbs.)	2760					
25	70	Mechanical Input Hp	4.72		35Q25L14	35Q25L18		L
		Thermal Input Hp	5.10		35Q25R14	35Q25R18		R
		Output Torque (lb in.)	3586		35Q25LR14	35Q25LR18		LR
		Mechanical Output Hp	3.98		35Q25H14	35Q25H18		HOLLOW
		Output OHL (lbs.)	2760					
30	58	Mechanical Input Hp	4.15	35Q30L56	35Q30L14	35Q30L18		L
		Thermal Input Hp	4.43	35Q30R56	35Q30R14	35Q30R18		R
		Output Torque (lb in.)	3682	35Q30LR56	35Q30LR14	35Q30LR18		LR
		Mechanical Output Hp	3.41	35Q30H56	35Q30H14	35Q30H18		HOLLOW
		Output OHL (lbs.)	2760					
40	44	Mechanical Input Hp	3.23	35Q40L56	35Q40L14	35Q40L18		L
		Thermal Input Hp	3.54	35Q40R56	35Q40R14	35Q40R18		R
		Output Torque (lb in.)	3622	35Q40LR56	35Q40LR14	35Q40LR18		LR
		Mechanical Output Hp	2.51	35Q40H56	35Q40H14	35Q40H18		HOLLOW
		Output OHL (lbs.)	2760					
50	35	Mechanical Input Hp	2.64	35Q50L56	35Q50L14			L
		Thermal Input Hp	2.94	35Q50R56	35Q50R14			R
		Output Torque (lb in.)	3485	35Q50LR56	35Q50LR14			LR
		Mechanical Output Hp	1.94	35Q50H56	35Q50H14			HOLLOW
		Output OHL (lbs.)	2760					
60	29	Mechanical Input Hp	2.19	35Q60L56	35Q60L14			L
		Thermal Input Hp	2.43	35Q60R56	35Q60R14			R
		Output Torque (lb in.)	3194	35Q60LR56	35Q60LR14			LR
		Mechanical Output Hp	1.48	35Q60H56	35Q60H14			HOLLOW
		Output OHL (lbs.)	2760					

Note: Reducers are shipped without a mounting base. Order bolt-on base kit **35BASE** if required.

FEATURES/BENEFITS PAGE G4-2	SPECIFICATION PAGE G4-8	NOMENCLATURE PAGE G4-9	MODIFICATION/ACCESSORIES PAGE G4-90
--------------------------------	----------------------------	---------------------------	--

SELECTION/DIMENSIONS



TIGEAR-2 QUILL INPUT - SIZE 35

SOLID OUTPUT

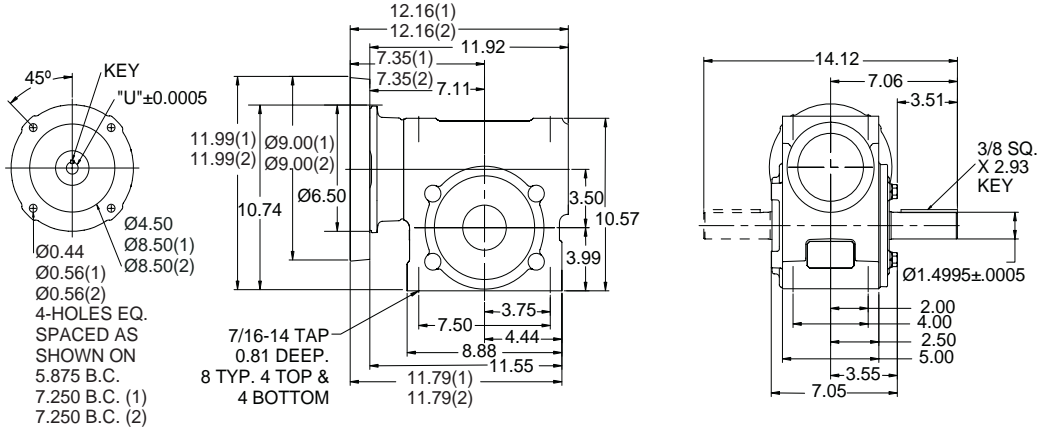

- (1) DIMENSIONS APPLY TO 180 FRAME MOTOR ADAPTER
 (2) DIMENSIONS APPLY TO 210 FRAME MOTOR ADAPTER

HOLLOW OUTPUT

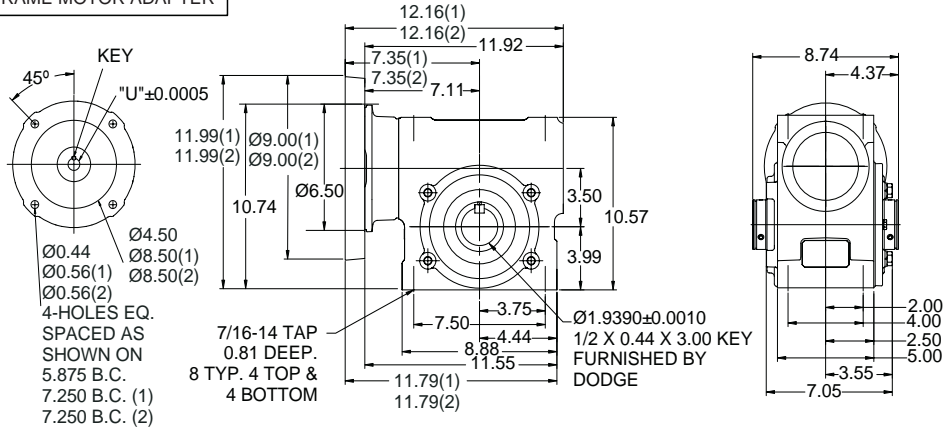

MOTOR FRAME	DIM "U"	KEY
48Y 56C	Ø0.626	3/16 SQ. X 2.43 KEY
140TC 160ATC	Ø0.876	3/16 SQ X 2.43 KEY
180TC 180ATC	Ø1.126	1/4 SQ. X 2.36 KEY
210TC 210ATC	Ø1.376	5/16 SQ X 2.57 KEY

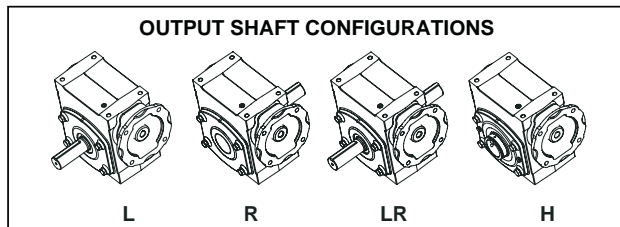

FEATURES/BENEFITS PAGE G4-2	SPECIFICATION PAGE G4-8	NOMENCLATURE PAGE G4-9	MODIFICATION/ACCESSORIES PAGE G4-90
--------------------------------	----------------------------	---------------------------	--



SELECTION/DIMENSIONS

TIGEAR-2 SEPARATE INPUT - SIZE 35

RATIO	OUTPUT RPM	RATING DATA 1750 INPUT RPM		SEPARATE REDUCER	SHAFT POSITION	OPTIONAL MOTOR ADAPTER KIT			
						56C	140TC	180TC	210TC
5	350	Mechanical Input Hp	15.18	35S05L 35S05R 35S05LR 35S05H	L R LR HOLLOW	35MTR14	35MTR18	35MTR21	
		Thermal Input Hp	15.51						
		Output Torque (lb in.)	2593						
		Mechanical Output Hp	14.40						
		Output OHL (lbs.)	2120						
7.5	233	Mechanical Input Hp	12.24	35S07L 35S07R 35S07LR 35S07H	L R LR HOLLOW	35MTR14	35MTR18	35MTR21	
		Thermal Input Hp	12.52						
		Output Torque (lb in.)	3054						
		Mechanical Output Hp	11.46						
		Output OHL (lbs.)	2430						
10	175	Mechanical Input Hp	10.00	35S10L 35S10R 35S10LR 35S10H	L R LR HOLLOW	35MTR14	35MTR18	35MTR21	
		Thermal Input Hp	10.63						
		Output Torque (lb in.)	3310						
		Mechanical Output Hp	9.19						
		Output OHL (lbs.)	2700						
12.7	138	Mechanical Input Hp	8.51	35S12L 35S12R 35S12LR 35S12H	L R LR HOLLOW	35MTR14	35MTR18	35MTR21	
		Thermal Input Hp	8.75						
		Output Torque (lb in.)	3530						
		Mechanical Output Hp	7.74						
		Output OHL (lbs.)	2760						
15	117	Mechanical Input Hp	7.44	35S15L 35S15R 35S15LR 35S15H	L R LR HOLLOW	35MTR14	35MTR18		
		Thermal Input Hp	7.56						
		Output Torque (lb in.)	3599						
		Mechanical Output Hp	6.66						
		Output OHL (lbs.)	2760						
20	88	Mechanical Input Hp	5.79	35S20L 35S20R 35S20LR 35S20H	L R LR HOLLOW	35MTR14	35MTR18		
		Thermal Input Hp	5.97						
		Output Torque (lb in.)	3620						
		Mechanical Output Hp	5.03						
		Output OHL (lbs.)	2760						
25	70	Mechanical Input Hp	4.72	35S25L 35S25R 35S25LR 35S25H	L R LR HOLLOW	35MTR14	35MTR18		
		Thermal Input Hp	5.10						
		Output Torque (lb in.)	3586						
		Mechanical Output Hp	3.98						
		Output OHL (lbs.)	2760						
30	58	Mechanical Input Hp	4.15	35S30L 35S30R 35S30LR 35S30H	L R LR HOLLOW	35MTR56	35MTR14	35MTR18	
		Thermal Input Hp	4.43						
		Output Torque (lb in.)	3682						
		Mechanical Output Hp	3.41						
		Output OHL (lbs.)	2760						
40	44	Mechanical Input Hp	3.23	35S40L 35S40R 35S40LR 35S40H	L R LR HOLLOW	35MTR56	35MTR14	35MTR18	
		Thermal Input Hp	3.54						
		Output Torque (lb in.)	3622						
		Mechanical Output Hp	2.51						
		Output OHL (lbs.)	2760						
50	35	Mechanical Input Hp	2.64	35S50L 35S50R 35S50LR 35S50H	L R LR HOLLOW	35MTR56	35MTR14		
		Thermal Input Hp	2.94						
		Output Torque (lb in.)	3485						
		Mechanical Output Hp	1.94						
		Output OHL (lbs.)	2760						
60	29	Mechanical Input Hp	2.19	35S60L 35S60R 35S60LR 35S60H	L R LR HOLLOW	35MTR56	35MTR14		
		Thermal Input Hp	2.43						
		Output Torque (lb in.)	3194						
		Mechanical Output Hp	1.48						
		Output OHL (lbs.)	2760						
All Ratios		Input OHL (lbs)	330	One diameter from seal surface					

Note: TIGEAR-2 separate reducers cannot be used with the old Adaptable TIGEAR motor adapter kits.

FEATURES/BENEFITS PAGE G4-2	SPECIFICATION PAGE G4-8	NOMENCLATURE PAGE G4-9	MODIFICATION/ACCESSORIES PAGE G4-90
--------------------------------	----------------------------	---------------------------	--

SELECTION/DIMENSIONS



Gearing Reference Guide

TORQUE-ARM II

TORQUE-ARM

MAXIMUM Concentric Reducer

TIGEAR-2

TIGEAR-2 SEPARATE INPUT - SIZE 35

SOLID OUTPUT

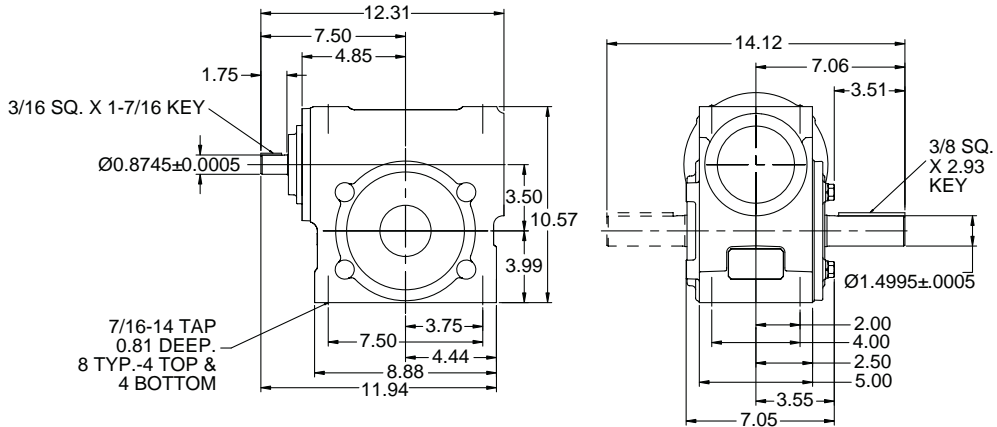

HOLLOW OUTPUT

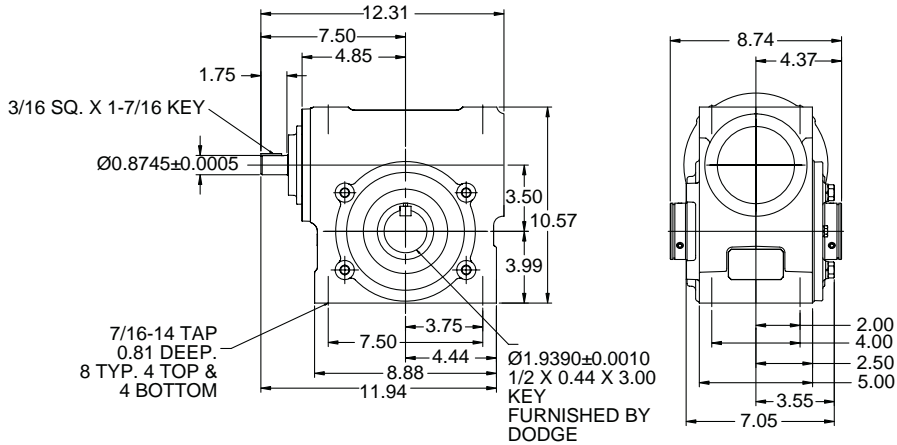

OUTPUT SHAFT CONFIGURATIONS

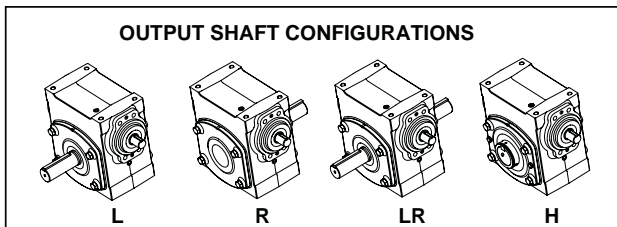

FEATURES/BENEFITS PAGE G4-2	SPECIFICATION PAGE G4-8	NOMENCLATURE PAGE G4-9	MODIFICATION/ACCESSORIES PAGE G4-90
--------------------------------	----------------------------	---------------------------	--

SELECTION/DIMENSIONS



TIGEAR-2 COUPLED INPUT - ADAPTER ASSEMBLY - SIZE 35

Coupled input units include a Separate reducer and motor adapter kit assembled together.

These assemblies are normally "made to order" with a 5 day standard lead time.

RATIO	OUTPUT RPM	RATING DATA 1750 INPUT RPM		PART NUMBER				SHAFT POSITION
				56C	140TC	180TC	210TC	
5	350	Mechanical Input Hp	15.18		35A05L14	35A05L18	35A05L21	L
		Thermal Input Hp	15.51		35A05R14	35A05R18	35A05R21	R
		Output Torque (lb in.)	2593		35A05LR14	35A05LR18	35A05LR21	LR
		Mechanical Output Hp	14.40		35A05H14	35A05H18	35A05H21	HOLLOW
		Output OHL (lbs.)	2120					
7.5	233	Mechanical Input Hp	12.24		35A07L14	35A07L18	35A07L21	L
		Thermal Input Hp	12.52		35A07R14	35A07R18	35A07R21	R
		Output Torque (lb in.)	3054		35A07LR14	35A07LR18	35A07LR21	LR
		Mechanical Output Hp	11.46		35A07H14	35A07H18	35A07H21	HOLLOW
		Output OHL (lbs.)	2430					
10	175	Mechanical Input Hp	10.00		35A10L14	35A10L18	35A10L21	L
		Thermal Input Hp	10.63		35A10R14	35A10R18	35A10R21	R
		Output Torque (lb in.)	3310		35A10LR14	35A10LR18	35A10LR21	LR
		Mechanical Output Hp	9.19		35A10H14	35A10H18	35A10H21	HOLLOW
		Output OHL (lbs.)	2700					
12.7	138	Mechanical Input Hp	8.51		35A12L14	35A12L18	35A12L21	L
		Thermal Input Hp	8.75		35A12R14	35A12R18	35A12R21	R
		Output Torque (lb in.)	3530		35A12LR14	35A12LR18	35A12LR21	LR
		Mechanical Output Hp	7.74		35A12H14	35A12H18	35A12H21	HOLLOW
		Output OHL (lbs.)	2760					
15	117	Mechanical Input Hp	7.44		35A15L14	35A15L18		L
		Thermal Input Hp	7.56		35A15R14	35A15R18		R
		Output Torque (lb in.)	3599		35A15LR14	35A15LR18		LR
		Mechanical Output Hp	6.66		35A15H14	35A15H18		HOLLOW
		Output OHL (lbs.)	2760					
20	88	Mechanical Input Hp	5.79		35A20L14	35A20L18		L
		Thermal Input Hp	5.97		35A20R14	35A20R18		R
		Output Torque (lb in.)	3620		35A20LR14	35A20LR18		LR
		Mechanical Output Hp	5.03		35A20H14	35A20H18		HOLLOW
		Output OHL (lbs.)	2760					
25	70	Mechanical Input Hp	4.72		35A25L14	35A25L18		L
		Thermal Input Hp	5.10		35A25R14	35A25R18		R
		Output Torque (lb in.)	3586		35A25LR14	35A25LR18		LR
		Mechanical Output Hp	3.98		35A25H14	35A25H18		HOLLOW
		Output OHL (lbs.)	2760					
30	58	Mechanical Input Hp	4.15	35A30L56	35A30L14	35A30L18		L
		Thermal Input Hp	4.43	35A30R56	35A30R14	35A30R18		R
		Output Torque (lb in.)	3682	35A30LR56	35A30LR14	35A30LR18		LR
		Mechanical Output Hp	3.41	35A30H56	35A30H14	35A30H18		HOLLOW
		Output OHL (lbs.)	2760					
40	44	Mechanical Input Hp	3.23	35A40L56	35A40L14	35A40L18		L
		Thermal Input Hp	3.54	35A40R56	35A40R14	35A40R18		R
		Output Torque (lb in.)	3622	35A40LR56	35A40LR14	35A40LR18		LR
		Mechanical Output Hp	2.51	35A40H56	35A40H14	35A40H18		HOLLOW
		Output OHL (lbs.)	2760					
50	35	Mechanical Input Hp	2.64	35A50L56	35A50L14			L
		Thermal Input Hp	2.94	35A50R56	35A50R14			R
		Output Torque (lb in.)	3485	35A50LR56	35A50LR14			LR
		Mechanical Output Hp	1.94	35A50H56	35A50H14			HOLLOW
		Output OHL (lbs.)	2760					
60	29	Mechanical Input Hp	2.19	35A60L56	35A60L14			L
		Thermal Input Hp	2.43	35A60R56	35A60R14			R
		Output Torque (lb in.)	3194	35A60LR56	35A60LR14			LR
		Mechanical Output Hp	1.48	35A60H56	35A60H14			HOLLOW
		Output OHL (lbs.)	2760					

Note: Reducers are shipped without a mounting base. Order bolt-on base kit **35BASE** if required.

FEATURES/BENEFITS PAGE G4-2	SPECIFICATION PAGE G4-8	NOMENCLATURE PAGE G4-9	MODIFICATION/ACCESSORIES PAGE G4-90
--------------------------------	----------------------------	---------------------------	--

SELECTION/DIMENSIONS



TIGEAR-2 COUPLED INPUT - ADAPTER ASSEMBLY - SIZE 35

SOLID OUTPUT

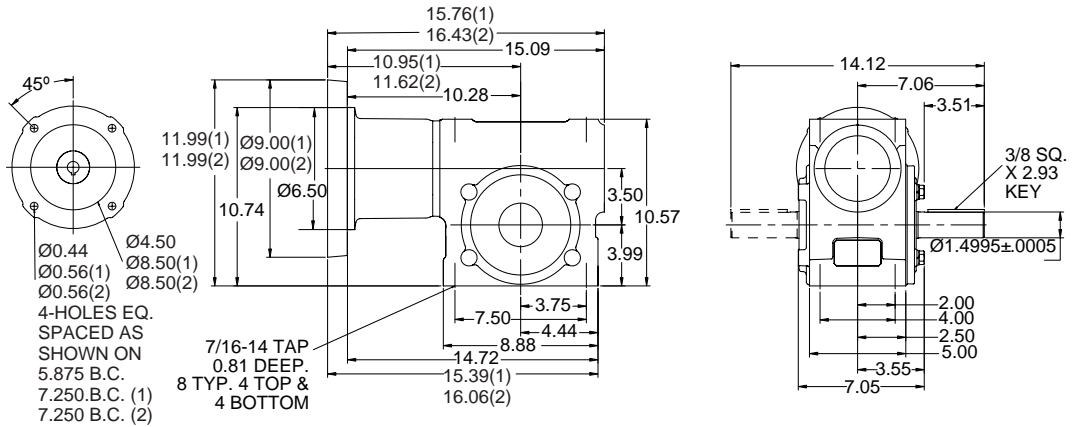

(1) DIMENSIONS APPLY TO 180 FRAME MOTOR ADAPTER

(2) DIMENSIONS APPLY TO 210 FRAME MOTOR ADAPTER

HOLLOW OUTPUT

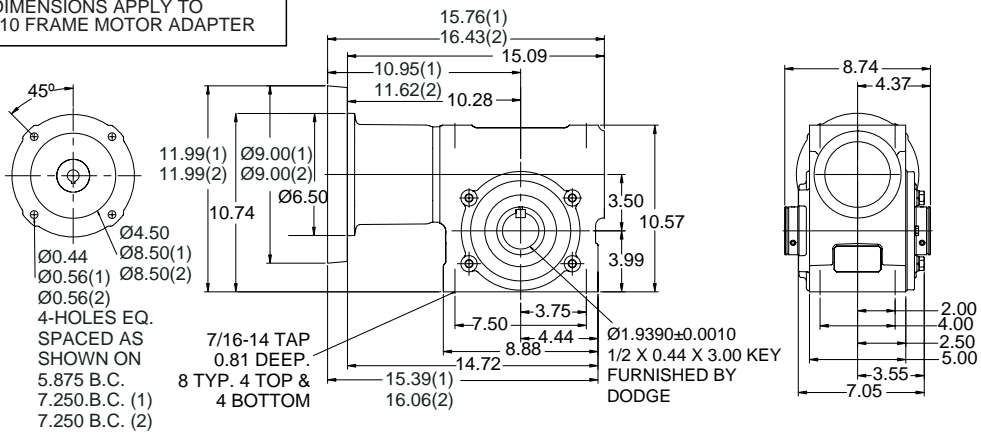

OUTPUT SHAFT CONFIGURATIONS

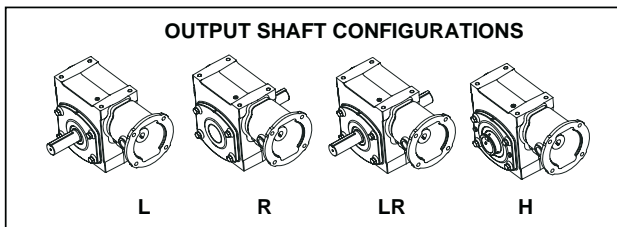

FEATURES/BENEFITS PAGE G4-2	SPECIFICATION PAGE G4-8	NOMENCLATURE PAGE G4-9	MODIFICATION/ACCESSORIES PAGE G4-90
--------------------------------	----------------------------	---------------------------	--

SELECTION/DIMENSIONS

DODGE®



TIGEAR-2 QUILL INPUT - SIZE 40

RATIO	OUTPUT RPM	RATING DATA 1750 INPUT RPM		PART NUMBER				SHAFT POSITION
				140TC	180TC	210TC	250TC	
5	350	Mechanical Input Hp	20.24			40Q05L21	40Q05L25	L
		Thermal Input Hp	22.20			40Q05R21	40Q05R25	R
		Output Torque (lb in.)	3449			40Q05LR21	40Q05LR25	LR
		Mechanical Output Hp	19.15			40Q05H21	40Q05H25	HOLLOW
		Output OHL (lbs.)	2860					
7.5	233	Mechanical Input Hp	16.38			40Q07L21	40Q07L25	L
		Thermal Input Hp	17.56			40Q07R21	40Q07R25	R
		Output Torque (lb in.)	4071			40Q07LR21	40Q07LR25	LR
		Mechanical Output Hp	15.27			40Q07H21	40Q07H25	HOLLOW
		Output OHL (lbs.)	3280					
10	175	Mechanical Input Hp	13.33			40Q10L21		L
		Thermal Input Hp	14.96			40Q10R21		R
		Output Torque (lb in.)	4418			40Q10LR21		LR
		Mechanical Output Hp	12.27			40Q10H21		HOLLOW
		Output OHL (lbs.)	3640					
15	117	Mechanical Input Hp	10.01		40Q15L18	40Q15L21		L
		Thermal Input Hp	10.16		40Q15R18	40Q15R21		R
		Output Torque (lb in.)	4804		40Q15LR18	40Q15LR21		LR
		Mechanical Output Hp	8.89		40Q15H18	40Q15H21		HOLLOW
		Output OHL (lbs.)	4190					
20	88	Mechanical Input Hp	7.75		40Q20L18	40Q20L21		L
		Thermal Input Hp	8.14		40Q20R18	40Q20R21		R
		Output Torque (lb in.)	4822		40Q20LR18	40Q20LR21		LR
		Mechanical Output Hp	6.69		40Q20H18	40Q20H21		HOLLOW
		Output OHL (lbs.)	4300					
25	70	Mechanical Input Hp	6.35		40Q25L18			L
		Thermal Input Hp	6.45		40Q25R18			R
		Output Torque (lb in.)	4722		40Q25LR18			LR
		Mechanical Output Hp	5.25		40Q25H18			HOLLOW
		Output OHL (lbs.)	4300					
30	58	Mechanical Input Hp	5.61		40Q30L18			L
		Thermal Input Hp	5.78		40Q30R18			R
		Output Torque (lb in.)	4898		40Q30LR18			LR
		Mechanical Output Hp	4.53		40Q30H18			HOLLOW
		Output OHL (lbs.)	4300					
40	44	Mechanical Input Hp	4.43	40Q40L14	40Q40L18			L
		Thermal Input Hp	4.50	40Q40R14	40Q40R18			R
		Output Torque (lb in.)	4800	40Q40LR14	40Q40LR18			LR
		Mechanical Output Hp	3.33	40Q40H14	40Q40H18			HOLLOW
		Output OHL (lbs.)	4300					
50	35	Mechanical Input Hp	3.63	40Q50L14	40Q50L18			L
		Thermal Input Hp	3.66	40Q50R14	40Q50R18			R
		Output Torque (lb in.)	4559	40Q50LR14	40Q50LR18			LR
		Mechanical Output Hp	2.53	40Q50H14	40Q50H18			HOLLOW
		Output OHL (lbs.)	4300					
60	29	Mechanical Input Hp	3.00	40Q60L14	40Q60L18			L
		Thermal Input Hp	3.21	40Q60R14	40Q60R18			R
		Output Torque (lb in.)	4166	40Q60LR14	40Q60LR18			LR
		Mechanical Output Hp	1.93	40Q60H14	40Q60H18			HOLLOW
		Output OHL (lbs.)	4300					

Note: Reducers are shipped without a mounting base. Order bolt-on base kit **40BASE** if required.

FEATURES/BENEFITS PAGE G4-2	SPECIFICATION PAGE G4-8	NOMENCLATURE PAGE G4-9	MODIFICATION/ACCESSORIES PAGE G4-90
--------------------------------	----------------------------	---------------------------	--

SELECTION/DIMENSIONS



TIGEAR-2 QUILL INPUT - SIZE 40

SOLID OUTPUT

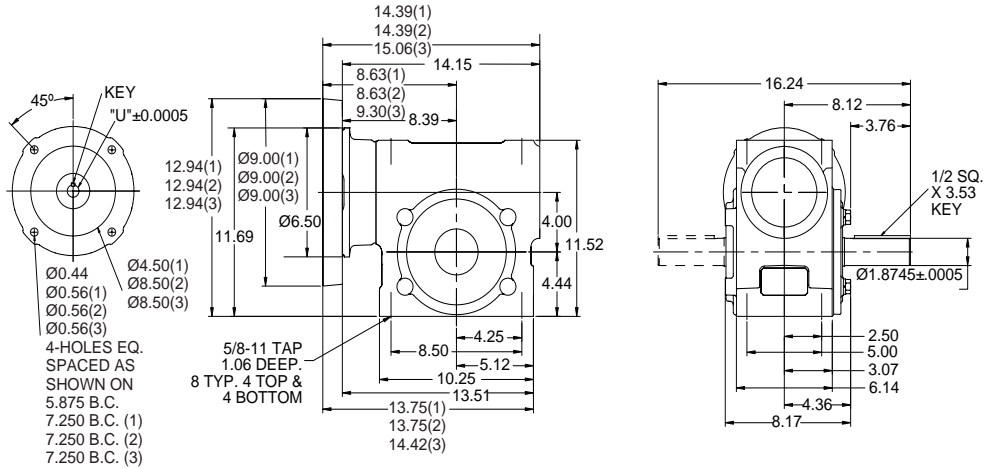

- (1) DIMENSIONS APPLY TO 180 FRAME MOTOR ADAPTER
- (2) DIMENSIONS APPLY TO 210 FRAME MOTOR ADAPTER
- (3) DIMENSIONS APPLY TO 250 FRAME MOTOR ADAPTER

HOLLOW OUTPUT

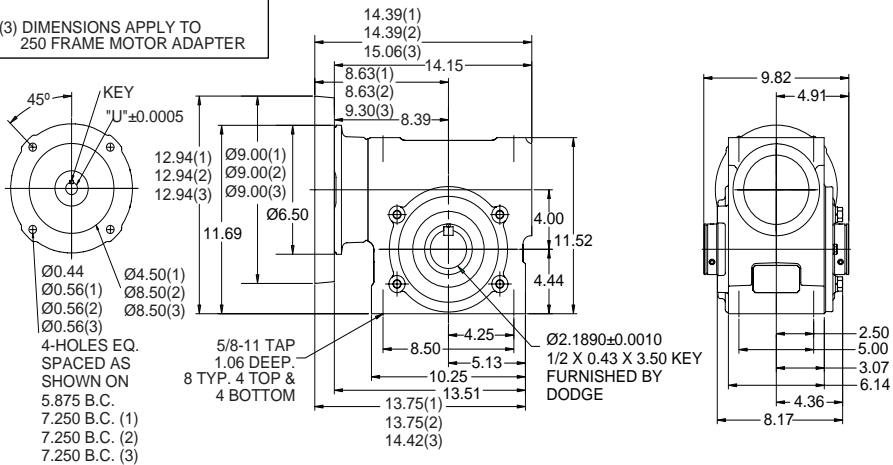

MOTOR FRAME	DIM "U"	KEY
140TC 160ATC	Ø0.876	3/16 SQ X 2.75 KEY
180TC 180ATC	Ø1.126	1/4 SQ. X 2.96 KEY
210TC 210ATC	Ø1.376	5/16 SQ X 3.11 KEY
250TC 250ATC	Ø1.626	3/8 SQ X 3.38 KEY

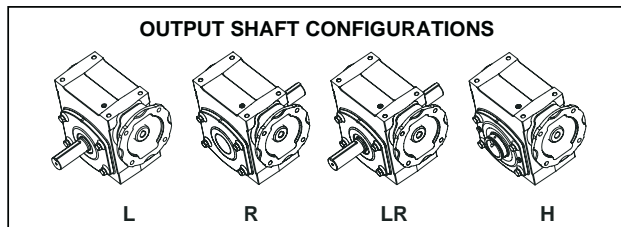

FEATURES/BENEFITS PAGE G4-2	SPECIFICATION PAGE G4-8	NOMENCLATURE PAGE G4-9	MODIFICATION/ACCESSORIES PAGE G4-90
--------------------------------	----------------------------	---------------------------	--



SELECTION/DIMENSIONS

TIGEAR-2 SEPARATE INPUT - SIZE 40

RATIO	OUTPUT RPM	RATING DATA		SEPARATE REDUCER	SHAFT POSITION	OPTIONAL MOTOR ADAPTER KIT			
		1750 INPUT RPM				140TC	180TC	210TC	250TC
5	350	Mechanical Input Hp	20.24	40S05L	L				
		Thermal Input Hp	22.20	40S05R	R				
		Output Torque (lb in.)	3449	40S05LR	LR			4047MTR21	4047MTR25
		Mechanical Output Hp	19.15	40S05H	HOLLOW				
		Output OHL (lbs.)	2860						
7.5	233	Mechanical Input Hp	16.38	40S07L	L				
		Thermal Input Hp	17.56	40S07R	R				
		Output Torque (lb in.)	4071	40S07LR	LR			4047MTR21	4047MTR25
		Mechanical Output Hp	15.27	40S07H	HOLLOW				
		Output OHL (lbs.)	3280						
10	175	Mechanical Input Hp	13.33	40S10L	L				
		Thermal Input Hp	14.96	40S10R	R				
		Output Torque (lb in.)	4418	40S10LR	LR			4047MTR21	
		Mechanical Output Hp	12.27	40S10H	HOLLOW				
		Output OHL (lbs.)	3640						
15	117	Mechanical Input Hp	10.01	40S15L	L				
		Thermal Input Hp	10.16	40S15R	R				
		Output Torque (lb in.)	4804	40S15LR	LR		4047MTR18	4047MTR21	
		Mechanical Output Hp	8.89	40S15H	HOLLOW				
		Output OHL (lbs.)	4190						
20	88	Mechanical Input Hp	7.75	40S20L	L				
		Thermal Input Hp	8.14	40S20R	R				
		Output Torque (lb in.)	4822	40S20LR	LR		4047MTR18	4047MTR21	
		Mechanical Output Hp	6.69	40S20H	HOLLOW				
		Output OHL (lbs.)	4300						
25	70	Mechanical Input Hp	6.35	40S25L	L				
		Thermal Input Hp	6.45	40S25R	R				
		Output Torque (lb in.)	4722	40S25LR	LR		4047MTR18		
		Mechanical Output Hp	5.25	40S25H	HOLLOW				
		Output OHL (lbs.)	4300						
30	58	Mechanical Input Hp	5.61	40S30L	L				
		Thermal Input Hp	5.78	40S30R	R				
		Output Torque (lb in.)	4898	40S30LR	LR		4047MTR18		
		Mechanical Output Hp	4.53	40S30H	HOLLOW				
		Output OHL (lbs.)	4300						
40	44	Mechanical Input Hp	4.43	40S40L	L				
		Thermal Input Hp	4.50	40S40R	R				
		Output Torque (lb in.)	4800	40S40LR	LR	4047MTR14	4047MTR18		
		Mechanical Output Hp	3.33	40S40H	HOLLOW				
		Output OHL (lbs.)	4300						
50	35	Mechanical Input Hp	3.63	40S50L	L				
		Thermal Input Hp	3.66	40S50R	R				
		Output Torque (lb in.)	4559	40S50LR	LR	4047MTR14	4047MTR18		
		Mechanical Output Hp	2.53	40S50H	HOLLOW				
		Output OHL (lbs.)	4300						
60	29	Mechanical Input Hp	3.00	40S60L	L				
		Thermal Input Hp	3.21	40S60R	R				
		Output Torque (lb in.)	4166	40S60LR	LR	4047MTR14	4047MTR18		
		Mechanical Output Hp	1.93	40S60H	HOLLOW				
		Output OHL (lbs.)	4300						
All Ratios		Input OHL (lbs)	400			One diameter from seal surface			

Note: Reducers are shipped without a mounting base. Order bolt-on base kit **40BASE** if required.

SELECTION/DIMENSIONS



TIGEAR-2 SEPARATE INPUT - SIZE 40

SOLID OUTPUT

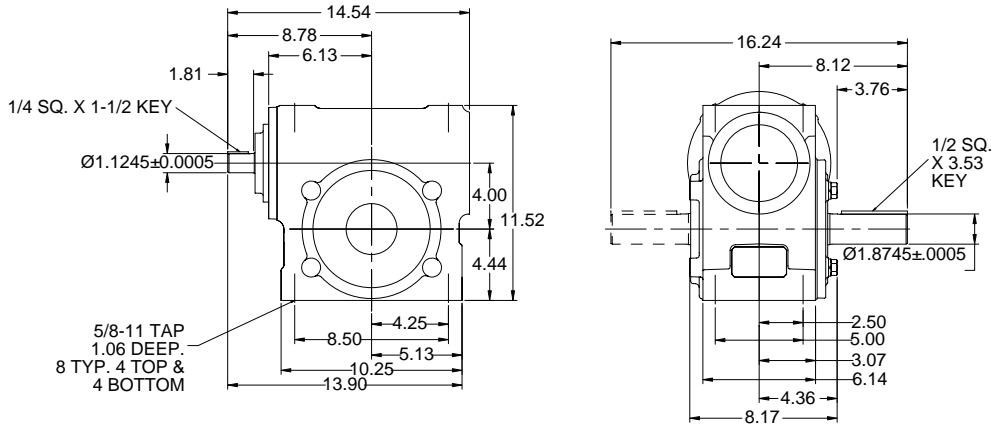

HOLLOW OUTPUT

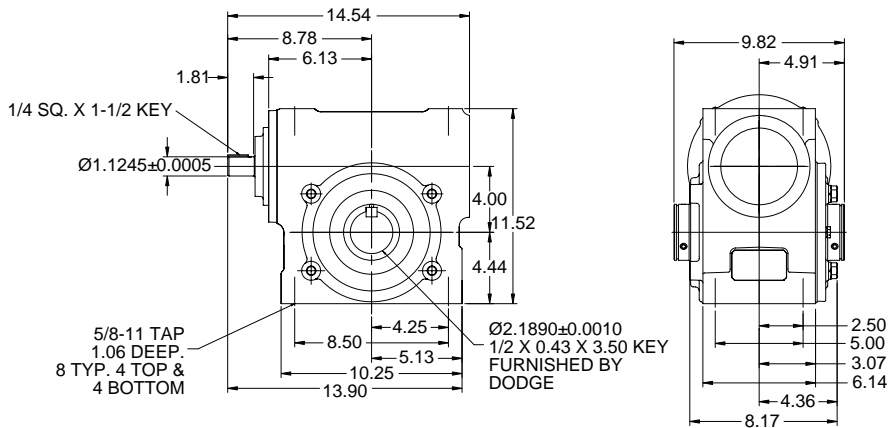

OUTPUT SHAFT CONFIGURATIONS

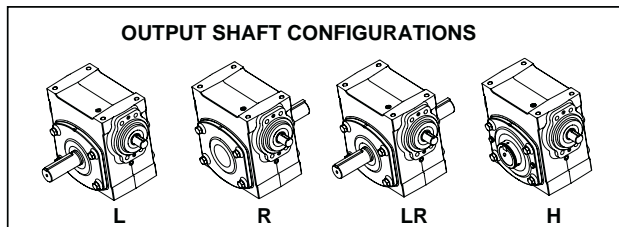



SELECTION/DIMENSIONS

TIGEAR-2 COUPLED INPUT - ADAPTER ASSEMBLY - SIZE 40

Coupled input units include a Separate reducer and motor adapter kit assembled together.

These assemblies are normally "made to order" with a 5 day standard lead time.

RATIO	OUTPUT RPM	RATING DATA 1750 INPUT RPM		PART NUMBER				SHAFT POSITION
				140TC	180TC	210TC	250TC	
5	350	Mechanical Input Hp	20.24			40A05L21	40A05L25	L
		Thermal Input Hp	22.20			40A05R21	40A05R25	R
		Output Torque (lb in.)	3449			40A05LR21	40A05LR25	LR
		Mechanical Output Hp	19.15			40A05H21	40A05H25	HOLLOW
		Output OHL (lbs.)	2860					
7.5	233	Mechanical Input Hp	16.38			40A07L21	40A07L25	L
		Thermal Input Hp	17.56			40A07R21	40A07R25	R
		Output Torque (lb in.)	4071			40A07LR21	40A07LR25	LR
		Mechanical Output Hp	15.27			40A07H21	40A07H25	HOLLOW
		Output OHL (lbs.)	3280					
10	175	Mechanical Input Hp	13.33			40A10L21		L
		Thermal Input Hp	14.96			40A10R21		R
		Output Torque (lb in.)	4418			40A10LR21		LR
		Mechanical Output Hp	12.27			40A10H21		HOLLOW
		Output OHL (lbs.)	3640					
15	117	Mechanical Input Hp	10.01		40A15L18	40A15L21		L
		Thermal Input Hp	10.16		40A15R18	40A15R21		R
		Output Torque (lb in.)	4804		40A15LR18	40A15LR21		LR
		Mechanical Output Hp	8.89		40A15H18	40A15H21		HOLLOW
		Output OHL (lbs.)	4190					
20	88	Mechanical Input Hp	7.75		40A20L18	40A20L21		L
		Thermal Input Hp	8.14		40A20R18	40A20R21		R
		Output Torque (lb in.)	4822		40A20LR18	40A20LR21		LR
		Mechanical Output Hp	6.69		40A20H18	40A20H21		HOLLOW
		Output OHL (lbs.)	4300					
25	70	Mechanical Input Hp	6.35		40A25L18			L
		Thermal Input Hp	6.45		40A25R18			R
		Output Torque (lb in.)	4722		40A25LR18			LR
		Mechanical Output Hp	5.25		40A25H18			HOLLOW
		Output OHL (lbs.)	4300					
30	58	Mechanical Input Hp	5.61		40A30L18			L
		Thermal Input Hp	5.78		40A30R18			R
		Output Torque (lb in.)	4898		40A30LR18			LR
		Mechanical Output Hp	4.53		40A30H18			HOLLOW
		Output OHL (lbs.)	4300					
40	44	Mechanical Input Hp	4.43	40A40L14	40A40L18			L
		Thermal Input Hp	4.50	40A40R14	40A40R18			R
		Output Torque (lb in.)	4800	40A40LR14	40A40LR18			LR
		Mechanical Output Hp	3.33	40A40H14	40A40H18			HOLLOW
		Output OHL (lbs.)	4300					
50	35	Mechanical Input Hp	3.63	40A50L14	40A50L18			L
		Thermal Input Hp	3.66	40A50R14	40A50R18			R
		Output Torque (lb in.)	4559	40A50LR14	40A50LR18			LR
		Mechanical Output Hp	2.53	40A50H14	40A50H18			HOLLOW
		Output OHL (lbs.)	4300					
60	29	Mechanical Input Hp	3.00	40A60L14	40A60L18			L
		Thermal Input Hp	3.21	40A60R14	40A60R18			R
		Output Torque (lb in.)	4166	40A60LR14	40A60LR18			LR
		Mechanical Output Hp	1.93	40A60H14	40A60H18			HOLLOW
		Output OHL (lbs.)	4300					

Note: Reducers are shipped without a mounting base. Order bolt-on base kit **40BASE** if required.

FEATURES/BENEFITS PAGE G4-2	SPECIFICATION PAGE G4-8	NOMENCLATURE PAGE G4-9	MODIFICATION/ACCESSORIES PAGE G4-90
--------------------------------	----------------------------	---------------------------	--

SELECTION/DIMENSIONS



TIGEAR-2 COUPLED INPUT - ADAPTER ASSEMBLY - SIZE 40

SOLID OUTPUT

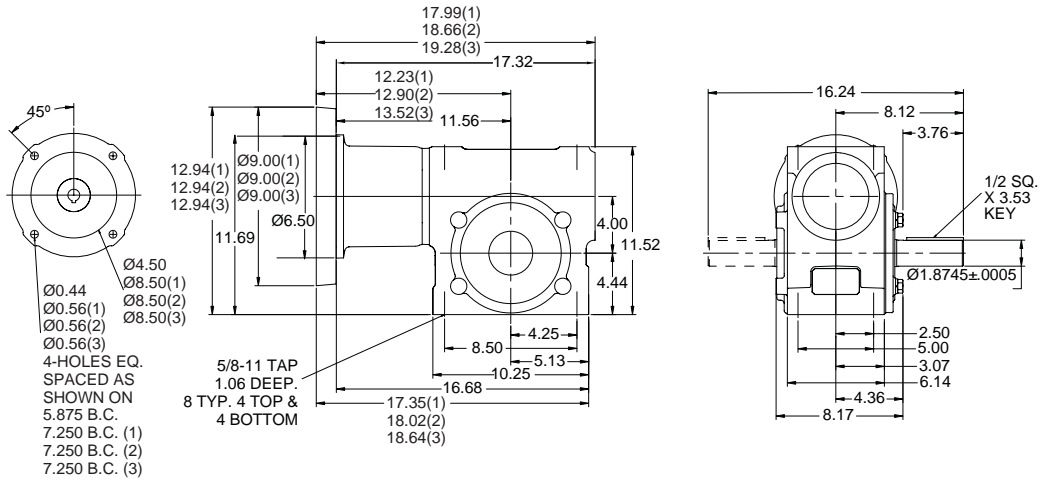

- (1) DIMENSIONS APPLY TO 180 FRAME MOTOR ADAPTER
- (2) DIMENSIONS APPLY TO 210 FRAME MOTOR ADAPTER
- (3) DIMENSIONS APPLY TO 250 FRAME MOTOR ADAPTER

HOLLOW OUTPUT

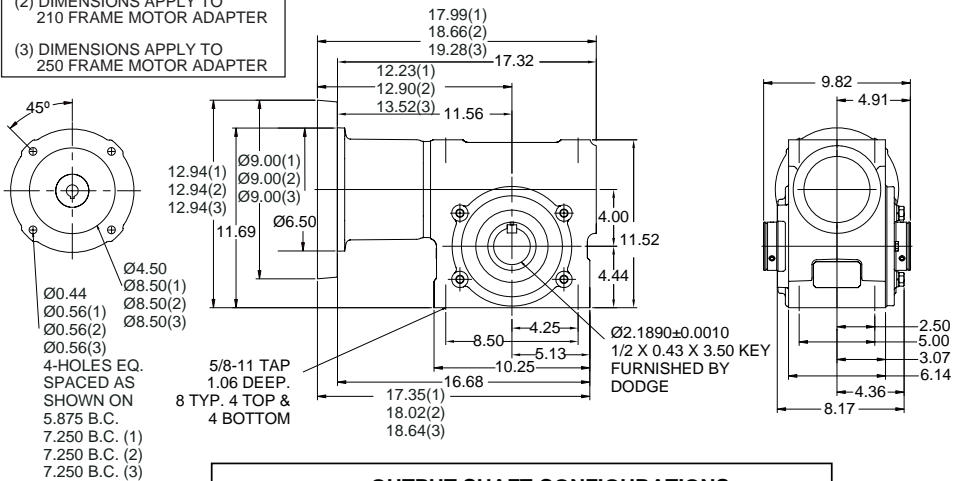

OUTPUT SHAFT CONFIGURATIONS

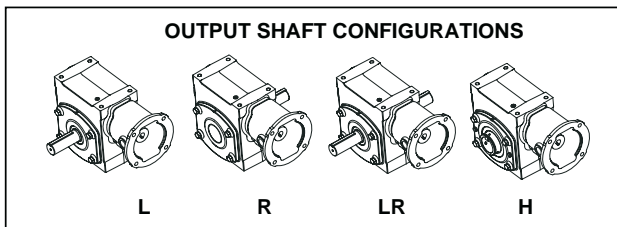

FEATURES/BENEFITS PAGE G4-2	SPECIFICATION PAGE G4-8	NOMENCLATURE PAGE G4-9	MODIFICATION/ACCESSORIES PAGE G4-90
--------------------------------	----------------------------	---------------------------	--

SELECTION/DIMENSIONS

DODGE®



TIGEAR-2 QUILL INPUT - SIZE 47

RATIO	OUTPUT RPM	RATING DATA 1750 INPUT RPM		PART NUMBER			SHAFT POSITION
				180TC	210TC	250TC	
5	350	Mechanical Input Hp	28.45			47Q05L25	L
		Thermal Input Hp	29.12			47Q05R25	R
		Output Torque (lb in.)	4832			47Q05LR25	LR
		Mechanical Output Hp	26.84			47Q05H25	HOLLOW
		Output OHL (lbs.)	5100				
7.5	233	Mechanical Input Hp	23.35			47Q07L25	L
		Thermal Input Hp	24.37			47Q07R25	R
		Output Torque (lb in.)	5801			47Q07LR25	LR
		Mechanical Output Hp	21.77			47Q07H25	HOLLOW
		Output OHL (lbs.)	5600				
10	175	Mechanical Input Hp	19.27		47Q10L21	47Q10L25	L
		Thermal Input Hp	20.08		47Q10R21	47Q10R25	R
		Output Torque (lb in.)	6390		47Q10LR21	47Q10LR25	LR
		Mechanical Output Hp	17.74		47Q10H21	47Q10H25	HOLLOW
		Output OHL (lbs.)	5600				
15	117	Mechanical Input Hp	14.05		47Q15L21		L
		Thermal Input Hp	14.14		47Q15R21		R
		Output Torque (lb in.)	6739		47Q15LR21		LR
		Mechanical Output Hp	12.47		47Q15H21		HOLLOW
		Output OHL (lbs.)	5600				
20	88	Mechanical Input Hp	10.82		47Q20L21		L
		Thermal Input Hp	10.96		47Q20R21		R
		Output Torque (lb in.)	6659		47Q20LR21		LR
		Mechanical Output Hp	9.24		47Q20H21		HOLLOW
		Output OHL (lbs.)	5600				
25	70	Mechanical Input Hp	8.76	47Q25L18	47Q25L21		L
		Thermal Input Hp	8.09	47Q25R18	47Q25R21		R
		Output Torque (lb in.)	6410	47Q25LR18	47Q25LR21		LR
		Mechanical Output Hp	7.12	47Q25H18	47Q25H21		HOLLOW
		Output OHL (lbs.)	5600				
30	58	Mechanical Input Hp	7.95	47Q30L18			L
		Thermal Input Hp	7.22	47Q30R18			R
		Output Torque (lb in.)	6845	47Q30LR18			LR
		Mechanical Output Hp	6.34	47Q30H18			HOLLOW
		Output OHL (lbs.)	5600				
40	44	Mechanical Input Hp	6.21	47Q40L18			L
		Thermal Input Hp	5.66	47Q40R18			R
		Output Torque (lb in.)	6644	47Q40LR18			LR
		Mechanical Output Hp	4.61	47Q40H18			HOLLOW
		Output OHL (lbs.)	5600				
50	35	Mechanical Input Hp	5.05	47Q50L18			L
		Thermal Input Hp	4.42	47Q50R18			R
		Output Torque (lb in.)	6241	47Q50LR18			LR
		Mechanical Output Hp	3.47	47Q50H18			HOLLOW
		Output OHL (lbs.)	5600				
60	29	Mechanical Input Hp	4.12	47Q60L18			L
		Thermal Input Hp	3.65	47Q60R18			R
		Output Torque (lb in.)	5683	47Q60LR18			LR
		Mechanical Output Hp	2.63	47Q60H18			HOLLOW
		Output OHL (lbs.)	5600				

Note: Reducers are shipped without a mounting base. Order bolt-on base kit **47BASE** if required.

SELECTION/DIMENSIONS



TIGEAR-2 QUILL INPUT - SIZE 47

SOLID OUTPUT

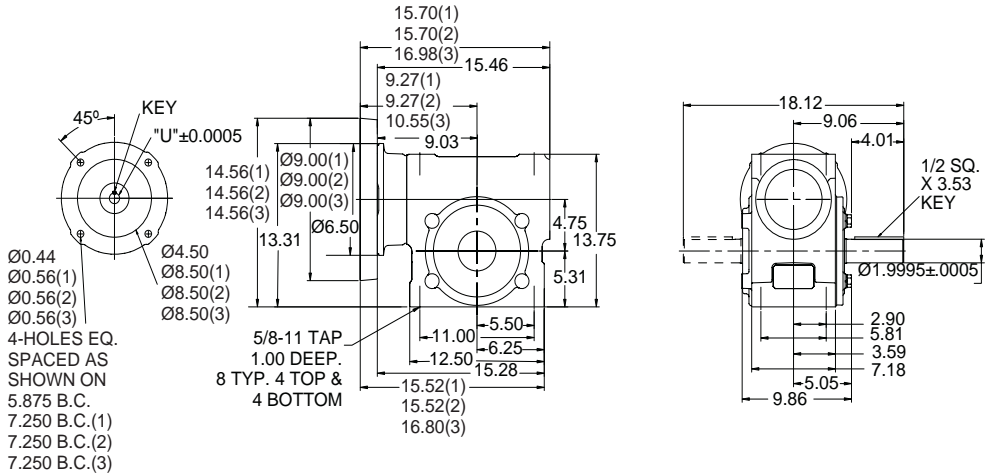

- (1) DIMENSIONS APPLY TO 180 FRAME MOTOR ADAPTER
 (2) DIMENSIONS APPLY TO 210 FRAME MOTOR ADAPTER
 (3) DIMENSIONS APPLY TO 250 FRAME MOTOR ADAPTER

HOLLOW OUTPUT

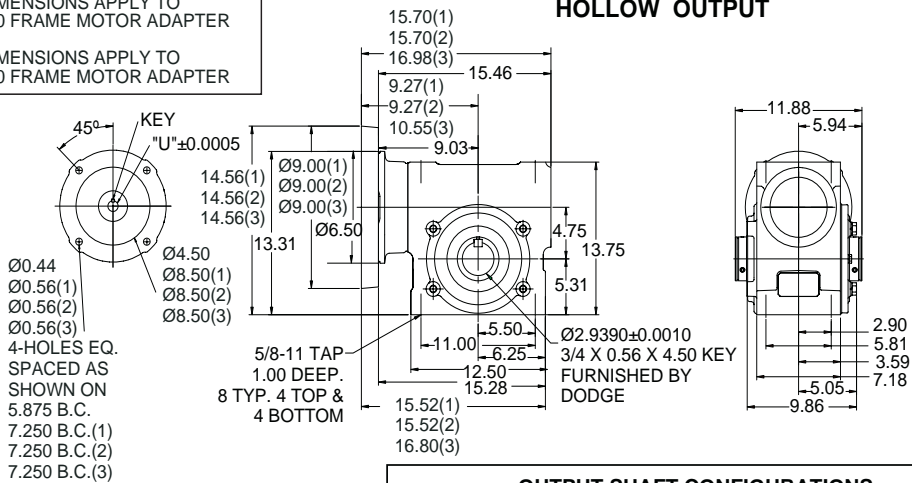

OUTPUT SHAFT CONFIGURATIONS

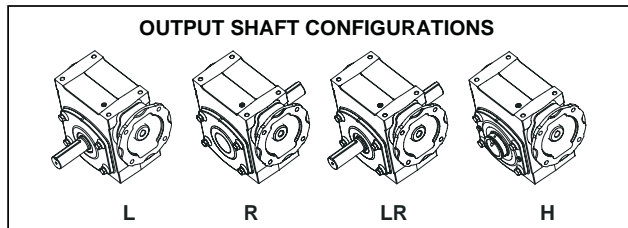

MOTOR FRAME	DIM "U"	KEY
140TC 160ATC	$\varnothing 0.876$	3/16 SQ X 2.75 KEY
180TC 180ATC	$\varnothing 1.126$	1/4 SQ. X 2.98 KEY
210TC 210ATC	$\varnothing 1.376$	5/16 SQ X 3.11 KEY
250TC 250ATC	$\varnothing 1.626$	3/8 SQ X 3.38 KEY

FEATURES/BENEFITS PAGE G4-2	SPECIFICATION PAGE G4-8	NOMENCLATURE PAGE G4-9	MODIFICATION/ACCESSORIES PAGE G4-90
--------------------------------	----------------------------	---------------------------	--

SELECTION/DIMENSIONS



TIGEAR-2 SEPARATE INPUT - SIZE 47

RATIO	OUTPUT RPM	RATING DATA 1750 INPUT RPM		SEPARATE REDUCER	SHAFT POSITION	OPTIONAL MOTOR ADAPTER KIT		
						180TC	210TC	250TC
5	350	Mechanical Input Hp	28.45	47S05L	L	4047MTR21	4047MTR25	
		Thermal Input Hp	29.12	47S05R	R			
		Output Torque (lb in.)	4832	47S05LR	LR			
		Mechanical Output Hp	26.84	47S05H	HOLLOW			
		Output OHL (lbs.)	5100					
7.5	233	Mechanical Input Hp	23.35	47S07L	L	4047MTR21	4047MTR25	
		Thermal Input Hp	24.37	47S07R	R			
		Output Torque (lb in.)	5801	47S07LR	LR			
		Mechanical Output Hp	21.77	47S07H	HOLLOW			
		Output OHL (lbs.)	5600					
10	175	Mechanical Input Hp	19.27	47S10L	L	4047MTR21		
		Thermal Input Hp	20.08	47S10R	R			
		Output Torque (lb in.)	6390	47S10LR	LR			
		Mechanical Output Hp	17.74	47S10H	HOLLOW			
		Output OHL (lbs.)	5600					
15	117	Mechanical Input Hp	14.05	47S15L	L	4047MTR18	4047MTR21	
		Thermal Input Hp	14.14	47S15R	R			
		Output Torque (lb in.)	6739	47S15LR	LR			
		Mechanical Output Hp	12.47	47S15H	HOLLOW			
		Output OHL (lbs.)	5600					
20	88	Mechanical Input Hp	10.82	47S20L	L	4047MTR18	4047MTR21	
		Thermal Input Hp	10.96	47S20R	R			
		Output Torque (lb in.)	6659	47S20LR	LR			
		Mechanical Output Hp	9.24	47S20H	HOLLOW			
		Output OHL (lbs.)	5600					
25	70	Mechanical Input Hp	8.76	47S25L	L	4047MTR18		
		Thermal Input Hp	8.09	47S25R	R			
		Output Torque (lb in.)	6410	47S25LR	LR			
		Mechanical Output Hp	7.12	47S25H	HOLLOW			
		Output OHL (lbs.)	5600					
30	58	Mechanical Input Hp	7.95	47S30L	L	4047MTR18		
		Thermal Input Hp	7.22	47S30R	R			
		Output Torque (lb in.)	6845	47S30LR	LR			
		Mechanical Output Hp	6.34	47S30H	HOLLOW			
		Output OHL (lbs.)	5600					
40	44	Mechanical Input Hp	6.21	47S40L	L	4047MTR18		
		Thermal Input Hp	5.66	47S40R	R			
		Output Torque (lb in.)	6644	47S40LR	LR			
		Mechanical Output Hp	4.61	47S40H	HOLLOW			
		Output OHL (lbs.)	5600					
50	35	Mechanical Input Hp	5.05	47S50L	L	4047MTR18		
		Thermal Input Hp	4.42	47S50R	R			
		Output Torque (lb in.)	6241	47S50LR	LR			
		Mechanical Output Hp	3.47	47S50H	HOLLOW			
		Output OHL (lbs.)	5600					
60	29	Mechanical Input Hp	4.12	47S60L	L			
		Thermal Input Hp	3.65	47S60R	R			
		Output Torque (lb in.)	5683	47S60LR	LR			
		Mechanical Output Hp	2.63	47S60H	HOLLOW			
		Output OHL (lbs.)	5600					
All Ratios		Input OHL (lbs)	500	One diameter from seal surface				

Note: TIGEAR-2 separate reducers cannot be used with the old Adaptable TIGEAR motor adapter kits.

FEATURES/BENEFITS PAGE G4-2	SPECIFICATION PAGE G4-8	NOMENCLATURE PAGE G4-9	MODIFICATION/ACCESSORIES PAGE G4-90
--------------------------------	----------------------------	---------------------------	--

SELECTION/DIMENSIONS



TIGEAR-2 SEPARATE INPUT - SIZE 47

SOLID OUTPUT

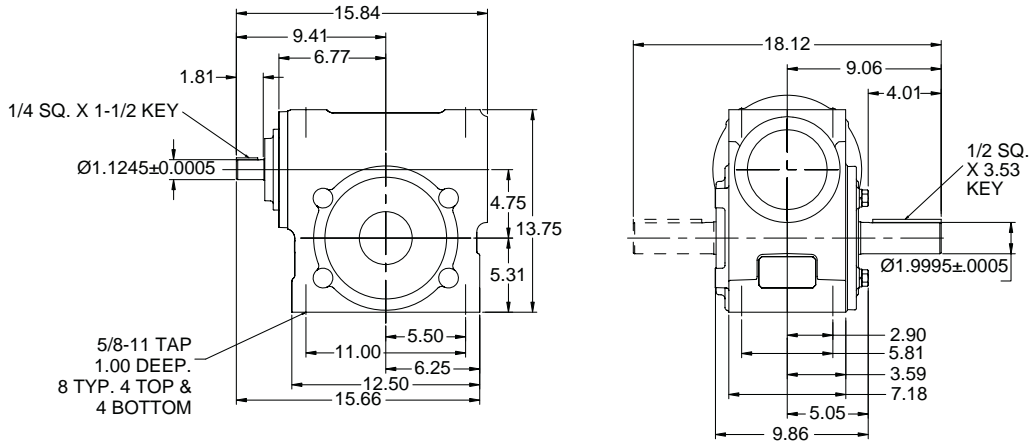

HOLLOW OUTPUT

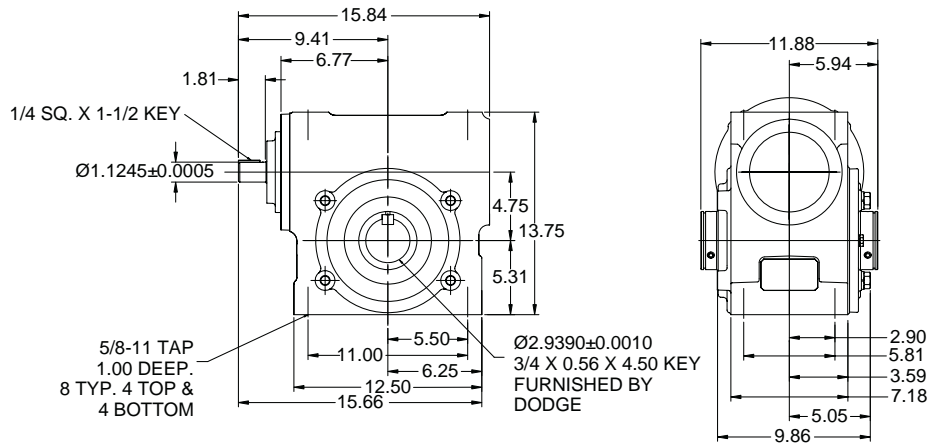

OUTPUT SHAFT CONFIGURATIONS

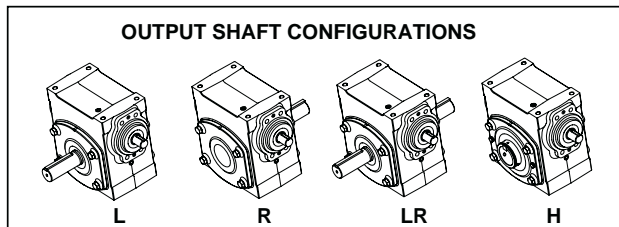



SELECTION/DIMENSIONS

TIGEAR-2 COUPLED INPUT - ADAPTER ASSEMBLY - SIZE 47

Coupled input units include a Separate reducer and motor adapter kit assembled together.

These assemblies are normally "made to order" with a 5 day standard lead time.

RATIO	OUTPUT RPM	RATING DATA 1750 INPUT RPM		PART NUMBER			SHAFT POSITION
				180TC	210TC	250TC	
5	350	Mechanical Input Hp	28.45			47A05L25	L
		Thermal Input Hp	29.12			47A05R25	R
		Output Torque (lb in.)	4832			47A05LR25	LR
		Mechanical Output Hp	26.84			47A05H25	HOLLOW
		Output OHL (lbs.)	5100				
7.5	233	Mechanical Input Hp	23.35			47A07L25	L
		Thermal Input Hp	24.37			47A07R25	R
		Output Torque (lb in.)	5801			47A07LR25	LR
		Mechanical Output Hp	21.77			47A07H25	HOLLOW
		Output OHL (lbs.)	5600				
10	175	Mechanical Input Hp	19.27		47A10L21	47A10L25	L
		Thermal Input Hp	20.08		47A10R21	47A10R25	R
		Output Torque (lb in.)	6390		47A10LR21	47A10LR25	LR
		Mechanical Output Hp	17.74		47A10H21	47A10H25	HOLLOW
		Output OHL (lbs.)	5600				
15	117	Mechanical Input Hp	14.05		47A15L21		L
		Thermal Input Hp	14.14		47A15R21		R
		Output Torque (lb in.)	6739		47A15LR21		LR
		Mechanical Output Hp	12.47		47A15H21		HOLLOW
		Output OHL (lbs.)	5600				
20	88	Mechanical Input Hp	10.82		47A20L21		L
		Thermal Input Hp	10.96		47A20R21		R
		Output Torque (lb in.)	6659		47A20LR21		LR
		Mechanical Output Hp	9.24		47A20H21		HOLLOW
		Output OHL (lbs.)	5600				
25	70	Mechanical Input Hp	8.76	47A25L18	47A25L21		L
		Thermal Input Hp	8.09	47A25R18	47A25R21		R
		Output Torque (lb in.)	6410	47A25LR18	47A25LR21		LR
		Mechanical Output Hp	7.12	47A25H18	47A25H21		HOLLOW
		Output OHL (lbs.)	5600				
30	58	Mechanical Input Hp	7.95	47A30L18			L
		Thermal Input Hp	7.22	47A30R18			R
		Output Torque (lb in.)	6845	47A30LR18			LR
		Mechanical Output Hp	6.34	47A30H18			HOLLOW
		Output OHL (lbs.)	5600				
40	44	Mechanical Input Hp	6.21	47A40L18			L
		Thermal Input Hp	5.66	47A40R18			R
		Output Torque (lb in.)	6644	47A40LR18			LR
		Mechanical Output Hp	4.61	47A40H18			HOLLOW
		Output OHL (lbs.)	5600				
50	35	Mechanical Input Hp	5.05	47A50L18			L
		Thermal Input Hp	4.42	47A50R18			R
		Output Torque (lb in.)	6241	47A50LR18			LR
		Mechanical Output Hp	3.47	47A50H18			HOLLOW
		Output OHL (lbs.)	5600				
60	29	Mechanical Input Hp	4.12	47A60L18			L
		Thermal Input Hp	3.65	47A60R18			R
		Output Torque (lb in.)	5683	47A60LR18			LR
		Mechanical Output Hp	2.63	47A60H18			HOLLOW
		Output OHL (lbs.)	5600				

Note: Reducers are shipped without a mounting base. Order bolt-on base kit **47BASE** if required.

FEATURES/BENEFITS PAGE G4-2	SPECIFICATION PAGE G4-8	NOMENCLATURE PAGE G4-9	MODIFICATION/ACCESSORIES PAGE G4-90
--------------------------------	----------------------------	---------------------------	--

SELECTION/DIMENSIONS



TIGEAR-2 COUPLED INPUT - ADAPTER ASSEMBLY - SIZE 47

SOLID OUTPUT

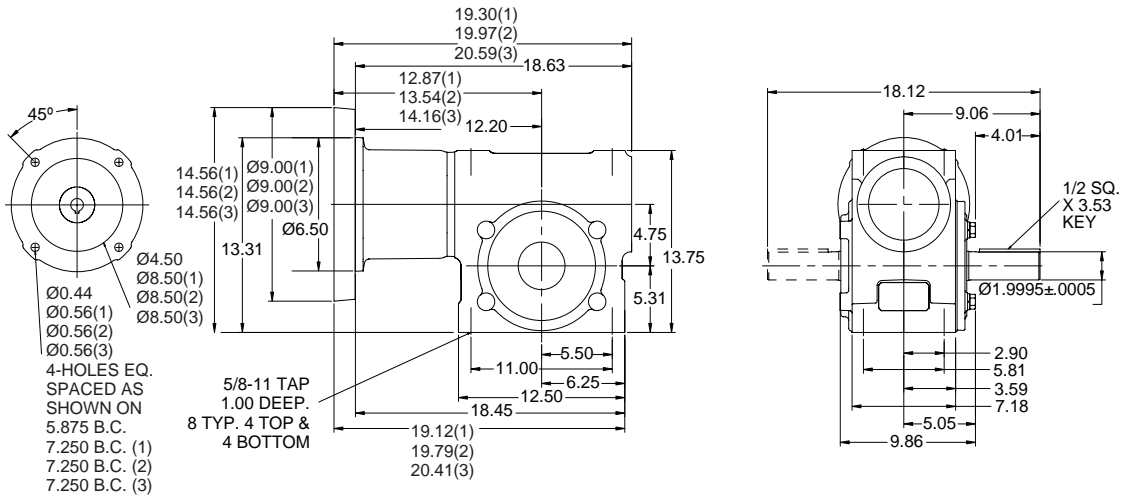

HOLLOW OUTPUT

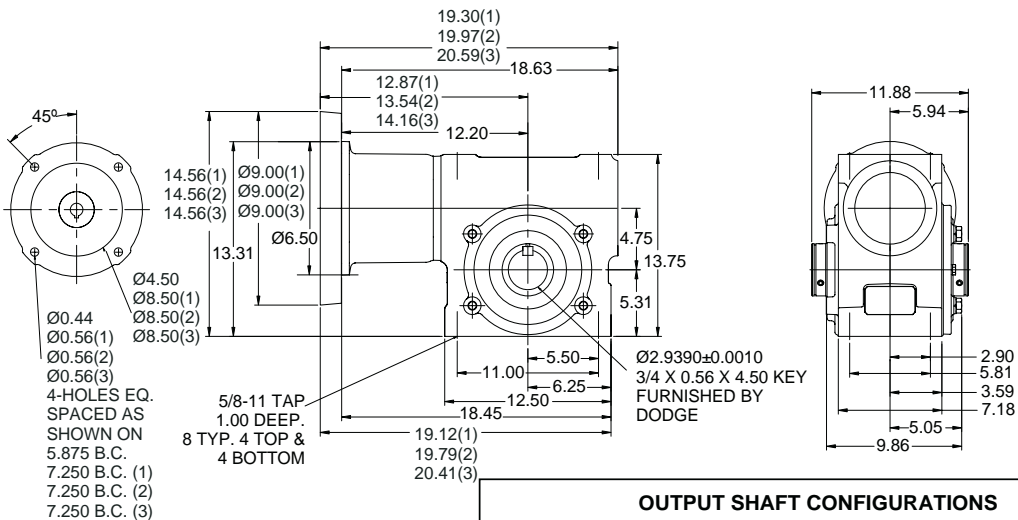

OUTPUT SHAFT CONFIGURATIONS

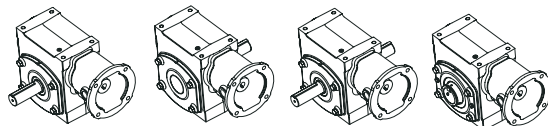

L

R

LR

H

(1) DIMENSIONS APPLY TO 180 FRAME MOTOR ADAPTER

(2) DIMENSIONS APPLY TO 210 FRAME MOTOR ADAPTER

(3) DIMENSIONS APPLY TO 250 FRAME MOTOR ADAPTER

FEATURES/BENEFITS PAGE G4-2	SPECIFICATION PAGE G4-8	NOMENCLATURE PAGE G4-9	MODIFICATION/ACCESSORIES PAGE G4-90
--------------------------------	----------------------------	---------------------------	--

WASHDOWN PRODUCTS



TIGEAR-2 E-Z KLEEN REDUCERS WITH QUILL INPUT

Sizes 13 - 23

RATIO	SHAFT POSITION	SIZE-13	SIZE-15	SIZE-17		SIZE-20		SIZE-23		
		56C	56C	56C	140TC	56C	140TC	56C	140TC	180TC
		Part Number	Part Number	Part Number	Part Number	Part Number	Part Number	Part Number	Part Number	Part Number
5	L	13QZ05L56	15QZ05L56	17QZ05L56	17QZ05L14	20QZ05L56	20QZ05L14	23QZ05L56	23QZ05L14	23QZ05L18
	R	13QZ05R56	15QZ05R56	17QZ05R56	17QZ05R14	20QZ05R56	20QZ05R14	23QZ05R56	23QZ05R14	23QZ05R18
	LR	13QZ05LR56	15QZ05LR56	17QZ05LR56	17QZ05LR14	20QZ05LR56	20QZ05LR14	23QZ05LR56	23QZ05LR14	23QZ05LR18
	HOLLOW	13QZ05H56	15QZ05H56	17QZ05H56	17QZ05H14	20QZ05H56	20QZ05H14	23QZ05H56	23QZ05H14	23QZ05H18
	HOLLOW ALT.					20QZ05HA56	20QZ05HA14	23QZ05HA56	23QZ05HA14	23QZ05HA18
7.5	L	13QZ07L56	15QZ07L56	17QZ07L56	17QZ07L14	20QZ07L56	20QZ07L14	23QZ07L56	23QZ07L14	23QZ07L18
	R	13QZ07R56	15QZ07R56	17QZ07R56	17QZ07R14	20QZ07R56	20QZ07R14	23QZ07R56	23QZ07R14	23QZ07R18
	LR	13QZ07LR56	15QZ07LR56	17QZ07LR56	17QZ07LR14	20QZ07LR56	20QZ07LR14	23QZ07LR56	23QZ07LR14	23QZ07LR18
	HOLLOW	13QZ07H56	15QZ07H56	17QZ07H56	17QZ07H14	20QZ07H56	20QZ07H14	23QZ07H56	23QZ07H14	23QZ07H18
	HOLLOW ALT.					20QZ07HA56	20QZ07HA14	23QZ07HA56	23QZ07HA14	23QZ07HA18
10	L	13QZ10L56	15QZ10L56	17QZ10L56	17QZ10L14	20QZ10L56	20QZ10L14	23QZ10L56	23QZ10L14	23QZ10L18
	R	13QZ10R56	15QZ10R56	17QZ10R56	17QZ10R14	20QZ10R56	20QZ10R14	23QZ10R56	23QZ10R14	23QZ10R18
	LR	13QZ10LR56	15QZ10LR56	17QZ10LR56	17QZ10LR14	20QZ10LR56	20QZ10LR14	23QZ10LR56	23QZ10LR14	23QZ10LR18
	HOLLOW	13QZ10H56	15QZ10H56	17QZ10H56	17QZ10H14	20QZ10H56	20QZ10H14	23QZ10H56	23QZ10H14	23QZ10H18
	HOLLOW ALT.					20QZ10HA56	20QZ10HA14	23QZ10HA56	23QZ10HA14	23QZ10HA18
15	L	13QZ15L56	15QZ15L56	17QZ15L56	17QZ15L14	20QZ15L56	20QZ15L14	23QZ15L56	23QZ15L14	
	R	13QZ15R56	15QZ15R56	17QZ15R56	17QZ15R14	20QZ15R56	20QZ15R14	23QZ15R56	23QZ15R14	
	LR	13QZ15LR56	15QZ15LR56	17QZ15LR56	17QZ15LR14	20QZ15LR56	20QZ15LR14	23QZ15LR56	23QZ15LR14	
	HOLLOW	13QZ15H56	15QZ15H56	17QZ15H56	17QZ15H14	20QZ15H56	20QZ15H14	23QZ15H56	23QZ15H14	
	HOLLOW ALT.					20QZ15HA56	20QZ15HA14	23QZ15HA56	23QZ15HA14	
20	L	13QZ20L56	15QZ20L56	17QZ20L56	17QZ20L14	20QZ20L56	20QZ20L14	23QZ20L56	23QZ20L14	
	R	13QZ20R56	15QZ20R56	17QZ20R56	17QZ20R14	20QZ20R56	20QZ20R14	23QZ20R56	23QZ20R14	
	LR	13QZ20LR56	15QZ20LR56	17QZ20LR56	17QZ20LR14	20QZ20LR56	20QZ20LR14	23QZ20LR56	23QZ20LR14	
	HOLLOW	13QZ20H56	15QZ20H56	17QZ20H56	17QZ20H14	20QZ20H56	20QZ20H14	23QZ20H56	23QZ20H14	
	HOLLOW ALT.					20QZ20HA56	20QZ20HA14	23QZ20HA56	23QZ20HA14	
25	L	13QZ25L56	15QZ25L56	17QZ25L56		20QZ25L56	20QZ25L14	23QZ25L56	23QZ25L14	
	R	13QZ25R56	15QZ25R56	17QZ25R56		20QZ25R56	20QZ25R14	23QZ25R56	23QZ25R14	
	LR	13QZ25LR56	15QZ25LR56	17QZ25LR56		20QZ25LR56	20QZ25LR14	23QZ25LR56	23QZ25LR14	
	HOLLOW	13QZ25H56	15QZ25H56	17QZ25H56		20QZ25H56	20QZ25H14	23QZ25H56	23QZ25H14	
	HOLLOW ALT.					20QZ25HA56	20QZ25HA14	23QZ25HA56	23QZ25HA14	
30	L	13QZ30L56	15QZ30L56	17QZ30L56		20QZ30L56		23QZ30L56	23QZ30L14	
	R	13QZ30R56	15QZ30R56	17QZ30R56		20QZ30R56		23QZ30R56	23QZ30R14	
	LR	13QZ30LR56	15QZ30LR56	17QZ30LR56		20QZ30LR56		23QZ30LR56	23QZ30LR14	
	HOLLOW	13QZ30H56	15QZ30H56	17QZ30H56		20QZ30H56		23QZ30H56	23QZ30H14	
	HOLLOW ALT.					20QZ30HA56		23QZ30HA56	23QZ30HA14	
40	L	13QZ40L56	15QZ40L56	17QZ40L56		20QZ40L56		23QZ40L56	23QZ40L14	
	R	13QZ40R56	15QZ40R56	17QZ40R56		20QZ40R56		23QZ40R56	23QZ40R14	
	LR	13QZ40LR56	15QZ40LR56	17QZ40LR56		20QZ40LR56		23QZ40LR56	23QZ40LR14	
	HOLLOW	13QZ40H56	15QZ40H56	17QZ40H56		20QZ40H56		23QZ40H56	23QZ40H14	
	HOLLOW ALT.					20QZ40HA56		23QZ40HA56	23QZ40HA14	
50	L	13QZ50L56	15QZ50L56	17QZ50L56		20QZ50L56		23QZ50L56		
	R	13QZ50R56	15QZ50R56	17QZ50R56		20QZ50R56		23QZ50R56		
	LR	13QZ50LR56	15QZ50LR56	17QZ50LR56		20QZ50LR56		23QZ50LR56		
	HOLLOW	13QZ50H56	15QZ50H56	17QZ50H56		20QZ50H56		23QZ50H56		
	HOLLOW ALT.					20QZ50HA56		23QZ50HA56		
60	L	13QZ60L56	15QZ60L56	17QZ60L56		20QZ60L56		23QZ60L56		
	R	13QZ60R56	15QZ60R56	17QZ60R56		20QZ60R56		23QZ60R56		
	LR	13QZ60LR56	15QZ60LR56	17QZ60LR56		20QZ60LR56		23QZ60LR56		
	HOLLOW	13QZ60H56	15QZ60H56	17QZ60H56		20QZ60H56		23QZ60H56		
	HOLLOW ALT.					20QZ60HA56		23QZ60HA56		

Note: Reducers are shipped without a mounting base. Order washdown bolt-on base kit from page G4-91 if required.

Additional washdown accessories available in Modifications / Accessories section of catalog.

Note: For reducer ratings and dimensions refer to Selection/Dimensions section of catalog.

FEATURES/BENEFITS PAGE G4-2	SPECIFICATION PAGE G4-8	NOMENCLATURE PAGE G4-9	MODIFICATION/ACCESSORIES PAGE G4-90
--------------------------------	----------------------------	---------------------------	--

TIGEAR-2 E-Z KLEEN REDUCERS WITH QUILL INPUT

Sizes 26 - 35

RATIO	SHAFT POSITION	SIZE-26			SIZE-30			SIZE-35			
		56C	140TC	180TC	56C	140TC	180TC	56C	140TC	180TC	210TC
		Part Number	Part Number	Part Number	Part Number	Part Number	Part Number	Part Number	Part Number	Part Number	Part Number
5	L		26QZ05L14	26QZ05L18		30QZ05L14	30QZ05L18		35QZ05L14	35QZ05L18	35QZ05L21
	R		26QZ05R14	26QZ05R18		30QZ05R14	30QZ05R18		35QZ05R14	35QZ05R18	35QZ05R21
	LR		26QZ05LR14	26QZ05LR18		30QZ05LR14	30QZ05LR18		35QZ05LR14	35QZ05LR18	35QZ05LR21
	HOLLOW		26QZ05H14	26QZ05H18		30QZ05H14	30QZ05H18		35QZ05H14	35QZ05H18	35QZ05H21
	HOLLOW ALT.		26QZ05HA14	26QZ05HA18							
7.5	L	26QZ07L56	26QZ07L14	26QZ07L18		30QZ07L14	30QZ07L18		35QZ07L14	35QZ07L18	35QZ07L21
	R	26QZ07R56	26QZ07R14	26QZ07R18		30QZ07R14	30QZ07R18		35QZ07R14	35QZ07R18	35QZ07R21
	LR	26QZ07LR56	26QZ07LR14	26QZ07LR18		30QZ07LR14	30QZ07LR18		35QZ07LR14	35QZ07LR18	35QZ07LR21
	HOLLOW	26QZ07H56	26QZ07H14	26QZ07H18		30QZ07H14	30QZ07H18		35QZ07H14	35QZ07H18	35QZ07H21
	HOLLOW ALT.	26QZ07HA56	26QZ07HA14	26QZ07HA18							
10	L	26QZ10L56	26QZ10L14	26QZ10L18		30QZ10L14	30QZ10L18		35QZ10L14	35QZ10L18	35QZ10L21
	R	26QZ10R56	26QZ10R14	26QZ10R18		30QZ10R14	30QZ10R18		35QZ10R14	35QZ10R18	35QZ10R21
	LR	26QZ10LR56	26QZ10LR14	26QZ10LR18		30QZ10LR14	30QZ10LR18		35QZ10LR14	35QZ10LR18	35QZ10LR21
	HOLLOW	26QZ10H56	26QZ10H14	26QZ10H18		30QZ10H14	30QZ10H18		35QZ10H14	35QZ10H18	35QZ10H21
	HOLLOW ALT.	26QZ10HA56	26QZ10HA14	26QZ10HA18							
15	L	26QZ15L56	26QZ15L14	26QZ15L18		30QZ15L14	30QZ15L18		35QZ15L14	35QZ15L18	
	R	26QZ15R56	26QZ15R14	26QZ15R18		30QZ15R14	30QZ15R18		35QZ15R14	35QZ15R18	
	LR	26QZ15LR56	26QZ15LR14	26QZ15LR18		30QZ15LR14	30QZ15LR18		35QZ15LR14	35QZ15LR18	
	HOLLOW	26QZ15H56	26QZ15H14	26QZ15H18		30QZ15H14	30QZ15H18		35QZ15H14	35QZ15H18	
	HOLLOW ALT.	26QZ15HA56	26QZ15HA14	26QZ15HA18							
20	L	26QZ20L56	26QZ20L14		30QZ20L56	30QZ20L14	30QZ20L18		35QZ20L14	35QZ20L18	
	R	26QZ20R56	26QZ20R14		30QZ20R56	30QZ20R14	30QZ20R18		35QZ20R14	35QZ20R18	
	LR	26QZ20LR56	26QZ20LR14		30QZ20LR56	30QZ20LR14	30QZ20LR18		35QZ20LR14	35QZ20LR18	
	HOLLOW	26QZ20H56	26QZ20H14		30QZ20H56	30QZ20H14	30QZ20H18		35QZ20H14	35QZ20H18	
	HOLLOW ALT.	26QZ20HA56	26QZ20HA14								
25	L	26QZ25L56	26QZ25L14		30QZ25L56	30QZ25L14	30QZ25L18		35QZ25L14	35QZ25L18	
	R	26QZ25R56	26QZ25R14		30QZ25R56	30QZ25R14	30QZ25R18		35QZ25R14	35QZ25R18	
	LR	26QZ25LR56	26QZ25LR14		30QZ25LR56	30QZ25LR14	30QZ25LR18		35QZ25LR14	35QZ25LR18	
	HOLLOW	26QZ25H56	26QZ25H14		30QZ25H56	30QZ25H14	30QZ25H18		35QZ25H14	35QZ25H18	
	HOLLOW ALT.	26QZ25HA56	26QZ25HA14								
30	L	26QZ30L56	26QZ30L14		30QZ30L56	30QZ30L14		35QZ30L56	35QZ30L14	35QZ30L18	
	R	26QZ30R56	26QZ30R14		30QZ30R56	30QZ30R14		35QZ30R56	35QZ30R14	35QZ30R18	
	LR	26QZ30LR56	26QZ30LR14		30QZ30LR56	30QZ30LR14		35QZ30LR56	35QZ30LR14	35QZ30LR18	
	HOLLOW	26QZ30H56	26QZ30H14		30QZ30H56	30QZ30H14		35QZ30H56	35QZ30H14	35QZ30H18	
	HOLLOW ALT.	26QZ30HA56	26QZ30HA14								
40	L	26QZ40L56	26QZ40L14		30QZ40L56	30QZ40L14		35QZ40L56	35QZ40L14	35QZ40L18	
	R	26QZ40R56	26QZ40R14		30QZ40R56	30QZ40R14		35QZ40R56	35QZ40R14	35QZ40R18	
	LR	26QZ40LR56	26QZ40LR14		30QZ40LR56	30QZ40LR14		35QZ40LR56	35QZ40LR14	35QZ40LR18	
	HOLLOW	26QZ40H56	26QZ40H14		30QZ40H56	30QZ40H14		35QZ40H56	35QZ40H14	35QZ40H18	
	HOLLOW ALT.	26QZ40HA56	26QZ40HA14								
50	L	26QZ50L56	26QZ50L14		30QZ50L56	30QZ50L14		35QZ50L56	35QZ50L14		
	R	26QZ50R56	26QZ50R14		30QZ50R56	30QZ50R14		35QZ50R56	35QZ50R14		
	LR	26QZ50LR56	26QZ50LR14		30QZ50LR56	30QZ50LR14		35QZ50LR56	35QZ50LR14		
	HOLLOW	26QZ50H56	26QZ50H14		30QZ50H56	30QZ50H14		35QZ50H56	35QZ50H14		
	HOLLOW ALT.	26QZ50HA56	26QZ50HA14								
60	L	26QZ60L56	26QZ60L14		30QZ60L56	30QZ60L14		35QZ60L56	35QZ60L14		
	R	26QZ60R56	26QZ60R14		30QZ60R56	30QZ60R14		35QZ60R56	35QZ60R14		
	LR	26QZ60LR56	26QZ60LR14		30QZ60LR56	30QZ60LR14		35QZ60LR56	35QZ60LR14		
	HOLLOW	26QZ60H56	26QZ60H14		30QZ60H56	30QZ60H14		35QZ60H56	35QZ60H14		
	HOLLOW ALT.	26QZ60HA56	26QZ60HA14								

Note: Reducers are shipped without a mounting base. Order washdown bolt-on base kit from page G4-91 if required.

Additional washdown accessories available in Modifications / Accessories section of catalog.

Note: For reducer ratings and dimensions refer to Selection/Dimensions section of catalog.

FEATURES/BENEFITS PAGE G4-2	SPECIFICATION PAGE G4-8	NOMENCLATURE PAGE G4-9	MODIFICATION/ACCESSORIES PAGE G4-90
--------------------------------	----------------------------	---------------------------	--

WASHDOWN PRODUCTS



TIGEAR-2 E-Z KLEEN REDUCERS WITH 3-PIECE COUPLED INPUT

Sizes 13 - 23

RATIO	SHAFT POSITION	SIZE-13		SIZE-15		SIZE-17		SIZE-20		SIZE-23				
		56C		56C		56C		140TC		56C		140TC		180TC
		Part Number	Part Number	Part Number	Part Number	Part Number	Part Number	Part Number	Part Number	Part Number	Part Number	Part Number	Part Number	
5	L	13AZ05L56	15AZ05L56	17AZ05L56	17AZ05L14	20AZ05L56	20AZ05L14	23AZ05L56	23AZ05L14	23AZ05L18				
	R	13AZ05R56	15AZ05R56	17AZ05R56	17AZ05R14	20AZ05R56	20AZ05R14	23AZ05R56	23AZ05R14	23AZ05R18				
	LR	13AZ05LR56	15AZ05LR56	17AZ05LR56	17AZ05LR14	20AZ05LR56	20AZ05LR14	23AZ05LR56	23AZ05LR14	23AZ05LR18				
	HOLLOW HOLLOW ALT.	13AZ05H56	15AZ05H56	17AZ05H56	17AZ05H14	20AZ05H56	20AZ05H14	23AZ05H56	23AZ05H14	23AZ05H18				
7.5	L	13AZ07L56	15AZ07L56	17AZ07L56	17AZ07L14	20AZ07L56	20AZ07L14	23AZ07L56	23AZ07L14	23AZ07L18				
	R	13AZ07R56	15AZ07R56	17AZ07R56	17AZ07R14	20AZ07R56	20AZ07R14	23AZ07R56	23AZ07R14	23AZ07R18				
	LR	13AZ07LR56	15AZ07LR56	17AZ07LR56	17AZ07LR14	20AZ07LR56	20AZ07LR14	23AZ07LR56	23AZ07LR14	23AZ07LR18				
	HOLLOW HOLLOW ALT.	13AZ07H56	15AZ07H56	17AZ07H56	17AZ07H14	20AZ07H56	20AZ07H14	23AZ07H56	23AZ07H14	23AZ07H18				
10	L	13AZ10L56	15AZ10L56	17AZ10L56	17AZ10L14	20AZ10L56	20AZ10L14	23AZ10L56	23AZ10L14	23AZ10L18				
	R	13AZ10R56	15AZ10R56	17AZ10R56	17AZ10R14	20AZ10R56	20AZ10R14	23AZ10R56	23AZ10R14	23AZ10R18				
	LR	13AZ10LR56	15AZ10LR56	17AZ10LR56	17AZ10LR14	20AZ10LR56	20AZ10LR14	23AZ10LR56	23AZ10LR14	23AZ10LR18				
	HOLLOW HOLLOW ALT.	13AZ10H56	15AZ10H56	17AZ10H56	17AZ10H14	20AZ10H56	20AZ10H14	23AZ10H56	23AZ10H14	23AZ10H18				
15	L	13AZ15L56	15AZ15L56	17AZ15L56	17AZ15L14	20AZ15L56	20AZ15L14	23AZ15L56	23AZ15L14					
	R	13AZ15R56	15AZ15R56	17AZ15R56	17AZ15R14	20AZ15R56	20AZ15R14	23AZ15R56	23AZ15R14					
	LR	13AZ15LR56	15AZ15LR56	17AZ15LR56	17AZ15LR14	20AZ15LR56	20AZ15LR14	23AZ15LR56	23AZ15LR14					
	HOLLOW HOLLOW ALT.	13AZ15H56	15AZ15H56	17AZ15H56	17AZ15H14	20AZ15H56	20AZ15H14	23AZ15H56	23AZ15H14					
20	L	13AZ20L56	15AZ20L56	17AZ20L56	17AZ20L14	20AZ20L56	20AZ20L14	23AZ20L56	23AZ20L14					
	R	13AZ20R56	15AZ20R56	17AZ20R56	17AZ20R14	20AZ20R56	20AZ20R14	23AZ20R56	23AZ20R14					
	LR	13AZ20LR56	15AZ20LR56	17AZ20LR56	17AZ20LR14	20AZ20LR56	20AZ20LR14	23AZ20LR56	23AZ20LR14					
	HOLLOW HOLLOW ALT.	13AZ20H56	15AZ20H56	17AZ20H56	17AZ20H14	20AZ20H56	20AZ20H14	23AZ20H56	23AZ20H14					
25	L	13AZ25L56	15AZ25L56	17AZ25L56		20AZ25L56	20AZ25L14	23AZ25L56	23AZ25L14					
	R	13AZ25R56	15AZ25R56	17AZ25R56		20AZ25R56	20AZ25R14	23AZ25R56	23AZ25R14					
	LR	13AZ25LR56	15AZ25LR56	17AZ25LR56		20AZ25LR56	20AZ25LR14	23AZ25LR56	23AZ25LR14					
	HOLLOW HOLLOW ALT.	13AZ25H56	15AZ25H56	17AZ25H56		20AZ25H56	20AZ25H14	23AZ25H56	23AZ25H14					
30	L	13AZ30L56	15AZ30L56	17AZ30L56		20AZ30L56		23AZ30L56	23AZ30L14					
	R	13AZ30R56	15AZ30R56	17AZ30R56		20AZ30R56		23AZ30R56	23AZ30R14					
	LR	13AZ30LR56	15AZ30LR56	17AZ30LR56		20AZ30LR56		23AZ30LR56	23AZ30LR14					
	HOLLOW HOLLOW ALT.	13AZ30H56	15AZ30H56	17AZ30H56		20AZ30H56		23AZ30H56	23AZ30H14					
40	L	13AZ40L56	15AZ40L56	17AZ40L56		20AZ40L56		23AZ40L56	23AZ40L14					
	R	13AZ40R56	15AZ40R56	17AZ40R56		20AZ40R56		23AZ40R56	23AZ40R14					
	LR	13AZ40LR56	15AZ40LR56	17AZ40LR56		20AZ40LR56		23AZ40LR56	23AZ40LR14					
	HOLLOW HOLLOW ALT.	13AZ40H56	15AZ40H56	17AZ40H56		20AZ40H56		23AZ40H56	23AZ40H14					
50	L	13AZ50L56	15AZ50L56	17AZ50L56		20AZ50L56		23AZ50L56						
	R	13AZ50R56	15AZ50R56	17AZ50R56		20AZ50R56		23AZ50R56						
	LR	13AZ50LR56	15AZ50LR56	17AZ50LR56		20AZ50LR56		23AZ50LR56						
	HOLLOW HOLLOW ALT.	13AZ50H56	15AZ50H56	17AZ50H56		20AZ50H56		23AZ50H56						
60	L	13AZ60L56	15AZ60L56	17AZ60L56		20AZ60L56		23AZ60L56						
	R	13AZ60R56	15AZ60R56	17AZ60R56		20AZ60R56		23AZ60R56						
	LR	13AZ60LR56	15AZ60LR56	17AZ60LR56		20AZ60LR56		23AZ60LR56						
	HOLLOW HOLLOW ALT.	13AZ60H56	15AZ60H56	17AZ60H56		20AZ60H56		23AZ60H56						

Note: Reducers are shipped without a mounting base. Order washdown bolt-on base kit from page G4-91 if required.

Additional washdown accessories available in Modifications / Accessories section of catalog.

Note: For reducer ratings and dimensions refer to Selection/Dimensions section of catalog.

FEATURES/BENEFITS PAGE G4-2	SPECIFICATION PAGE G4-8	NOMENCLATURE PAGE G4-9	MODIFICATION/ACCESSORIES PAGE G4-90
--------------------------------	----------------------------	---------------------------	--

TIGEAR-2 E-Z KLEEN REDUCERS WITH 3-PIECE COUPLED INPUT

Sizes 26-35

RATIO	SHAFT POSITION	SIZE-26			SIZE-30			SIZE-35			
		56C	140TC	180TC	56C	140TC	180TC	56C	140TC	180TC	210TC
		Part Number	Part Number	Part Number	Part Number	Part Number	Part Number	Part Number	Part Number	Part Number	Part Number
5	L		26AZ05L14	26AZ05L18		30AZ05L14	30AZ05L18		35AZ05L14	35AZ05L18	35AZ05L21
	R		26AZ05R14	26AZ05R18		30AZ05R14	30AZ05R18		35AZ05R14	35AZ05R18	35AZ05R21
	LR		26AZ05LR14	26AZ05LR18		30AZ05LR14	30AZ05LR18		35AZ05LR14	35AZ05LR18	35AZ05LR21
	HOLLOW		26AZ05H14	26AZ05H18		30AZ05H14	30AZ05H18		35AZ05H14	35AZ05H18	35AZ05H21
	HOLLOW ALT.		26AZ05HA14	26AZ05HA18							
7.5	L	26AZ07L56	26AZ07L14	26AZ07L18		30AZ07L14	30AZ07L18		35AZ07L14	35AZ07L18	35AZ07L21
	R	26AZ07R56	26AZ07R14	26AZ07R18		30AZ07R14	30AZ07R18		35AZ07R14	35AZ07R18	35AZ07R21
	LR	26AZ07LR56	26AZ07LR14	26AZ07LR18		30AZ07LR14	30AZ07LR18		35AZ07LR14	35AZ07LR18	35AZ07LR21
	HOLLOW	26AZ07H56	26AZ07H14	26AZ07H18		30AZ07H14	30AZ07H18		35AZ07H14	35AZ07H18	35AZ07H21
	HOLLOW ALT.	26AZ07HA56	26AZ07HA14	26AZ07HA18							
10	L	26AZ10L56	26AZ10L14	26AZ10L18		30AZ10L14	30AZ10L18		35AZ10L14	35AZ10L18	35AZ10L21
	R	26AZ10R56	26AZ10R14	26AZ10R18		30AZ10R14	30AZ10R18		35AZ10R14	35AZ10R18	35AZ10R21
	LR	26AZ10LR56	26AZ10LR14	26AZ10LR18		30AZ10LR14	30AZ10LR18		35AZ10LR14	35AZ10LR18	35AZ10LR21
	HOLLOW	26AZ10H56	26AZ10H14	26AZ10H18		30AZ10H14	30AZ10H18		35AZ10H14	35AZ10H18	35AZ10H21
	HOLLOW ALT.	26AZ10HA56	26AZ10HA14	26AZ10HA18							
15	L	26AZ15L56	26AZ15L14	26AZ15L18		30AZ15L14	30AZ15L18		35AZ15L14	35AZ15L18	
	R	26AZ15R56	26AZ15R14	26AZ15R18		30AZ15R14	30AZ15R18		35AZ15R14	35AZ15R18	
	LR	26AZ15LR56	26AZ15LR14	26AZ15LR18		30AZ15LR14	30AZ15LR18		35AZ15LR14	35AZ15LR18	
	HOLLOW	26AZ15H56	26AZ15H14	26AZ15H18		30AZ15H14	30AZ15H18		35AZ15H14	35AZ15H18	
	HOLLOW ALT.	26AZ15HA56	26AZ15HA14	26AZ15HA18							
20	L	26AZ20L56	26AZ20L14		30AZ20L56	30AZ20L14	30AZ20L18		35AZ20L14	35AZ20L18	
	R	26AZ20R56	26AZ20R14		30AZ20R56	30AZ20R14	30AZ20R18		35AZ20R14	35AZ20R18	
	LR	26AZ20LR56	26AZ20LR14		30AZ20LR56	30AZ20LR14	30AZ20LR18		35AZ20LR14	35AZ20LR18	
	HOLLOW	26AZ20H56	26AZ20H14		30AZ20H56	30AZ20H14	30AZ20H18		35AZ20H14	35AZ20H18	
	HOLLOW ALT.	26AZ20HA56	26AZ20HA14								
25	L	26AZ25L56	26AZ25L14		30AZ25L56	30AZ25L14	30AZ25L18		35AZ25L14	35AZ25L18	
	R	26AZ25R56	26AZ25R14		30AZ25R56	30AZ25R14	30AZ25R18		35AZ25R14	35AZ25R18	
	LR	26AZ25LR56	26AZ25LR14		30AZ25LR56	30AZ25LR14	30AZ25LR18		35AZ25LR14	35AZ25LR18	
	HOLLOW	26AZ25H56	26AZ25H14		30AZ25H56	30AZ25H14	30AZ25H18		35AZ25H14	35AZ25H18	
	HOLLOW ALT.	26AZ25HA56	26AZ25HA14								
30	L	26AZ30L56	26AZ30L14		30AZ30L56	30AZ30L14		35AZ30L56	35AZ30L14	35AZ30L18	
	R	26AZ30R56	26AZ30R14		30AZ30R56	30AZ30R14		35AZ30R56	35AZ30R14	35AZ30R18	
	LR	26AZ30LR56	26AZ30LR14		30AZ30LR56	30AZ30LR14		35AZ30LR56	35AZ30LR14	35AZ30LR18	
	HOLLOW	26AZ30H56	26AZ30H14		30AZ30H56	30AZ30H14		35AZ30H56	35AZ30H14	35AZ30H18	
	HOLLOW ALT.	26AZ30HA56	26AZ30HA14								
40	L	26AZ40L56	26AZ40L14		30AZ40L56	30AZ40L14		35AZ40L56	35AZ40L14	35AZ40L18	
	R	26AZ40R56	26AZ40R14		30AZ40R56	30AZ40R14		35AZ40R56	35AZ40R14	35AZ40R18	
	LR	26AZ40LR56	26AZ40LR14		30AZ40LR56	30AZ40LR14		35AZ40LR56	35AZ40LR14	35AZ40LR18	
	HOLLOW	26AZ40H56	26AZ40H14		30AZ40H56	30AZ40H14		35AZ40H56	35AZ40H14	35AZ40H18	
	HOLLOW ALT.	26AZ40HA56	26AZ40HA14								
50	L	26AZ50L56	26AZ50L14		30AZ50L56	30AZ50L14		35AZ50L56	35AZ50L14		
	R	26AZ50R56	26AZ50R14		30AZ50R56	30AZ50R14		35AZ50R56	35AZ50R14		
	LR	26AZ50LR56	26AZ50LR14		30AZ50LR56	30AZ50LR14		35AZ50LR56	35AZ50LR14		
	HOLLOW	26AZ50H56	26AZ50H14		30AZ50H56	30AZ50H14		35AZ50H56	35AZ50H14		
	HOLLOW ALT.	26AZ50HA56	26AZ50HA14								
60	L	26AZ60L56	26AZ60L14		30AZ60L56	30AZ60L14		35AZ60L56	35AZ60L14		
	R	26AZ60R56	26AZ60R14		30AZ60R56	30AZ60R14		35AZ60R56	35AZ60R14		
	LR	26AZ60LR56	26AZ60LR14		30AZ60LR56	30AZ60LR14		35AZ60LR56	35AZj60LR14		
	HOLLOW	26AZ60H56	26AZ60H14		30AZ60H56	30AZ60H14		35AZ60H56	35AZ60H14		
	HOLLOW ALT.	26AZ60HA56	26AZ60HA14								

Note: Reducers are shipped without a mounting base. Order washdown bolt-on base kit from page G4-91 if required.

Additional washdown accessories available in Modifications / Accessories section of catalog.

Note: For reducer ratings and dimensions refer to Selection/Dimensions section of catalog.

FEATURES/BENEFITS PAGE G4-2	SPECIFICATION PAGE G4-8	NOMENCLATURE PAGE G4-9	MODIFICATION/ACCESSORIES PAGE G4-90
--------------------------------	----------------------------	---------------------------	--



WASHDOWN PRODUCTS

TIGEAR-2 STAINLESS STEEL ULTRA KLEEN REDUCERS WITH QUILL INPUT

Available By June 2005

RATIO	SHAFT POSITION	SIZE-17				SIZE-23			SIZE-30			SIZE-35					
		56C		140TC		56C		140TC	180TC		56C		140TC		180TC		210TC
		Part Number	Part Number	Part Number	Part Number	Part Number	Part Number	Part Number	Part Number	Part Number	Part Number	Part Number	Part Number	Part Number	Part Number	Part Number	Part Number
5	L	17QS05L56	17QS05L14	23QS05L56	23QS05L14	23QS05L18		30QS05L14	30QS05L18		35QS05L14	35QS05L18	35QS05L21				
	R	17QS05R56	17QS05R14	23QS05R56	23QS05R14	23QS05R18		30QS05R14	30QS05R18		35QS05R14	35QS05R18	35QS05R21				
	LR	17QS05LR56	17QS05LR14	23QS05LR56	23QS05LR14	23QS05LR18		30QS05LR14	30QS05LR18		35QS05LR14	35QS05LR18	35QS05LR21				
	HOLLOW HOLLOW ALT.	17QS05H56	17QS05H14	23QS05H56	23QS05H14	23QS05H18		30QS05H14	30QS05H18		35QS05H14	35QS05H18	35QS05H21				
7.5	L	17QS07L56	17QS07L14	23QS07L56	23QS07L14	23QS07L18		30QS07L14	30QS07L18		35QS07L14	35QS07L18	35QS07L21				
	R	17QS07R56	17QS07R14	23QS07R56	23QS07R14	23QS07R18		30QS07R14	30QS07R18		35QS07R14	35QS07R18	35QS07R21				
	LR	17QS07LR56	17QS07LR14	23QS07LR56	23QS07LR14	23QS07LR18		30QS07LR14	30QS07LR18		35QS07LR14	35QS07LR18	35QS07LR21				
	HOLLOW HOLLOW ALT.	17QS07H56	17QS07H14	23QS07H56	23QS07H14	23QS07H18		30QS07H14	30QS07H18		35QS07H14	35QS07H18	35QS07H21				
10	L	17QS10L56	17QS10L14	23QS10L56	23QS10L14	23QS10L18		30QS10L14	30QS10L18		35QS10L14	35QS10L18	35QS10L21				
	R	17QS10R56	17QS10R14	23QS10R56	23QS10R14	23QS10R18		30QS10R14	30QS10R18		35QS10R14	35QS10R18	35QS10R21				
	LR	17QS10LR56	17QS10LR14	23QS10LR56	23QS10LR14	23QS10LR18		30QS10LR14	30QS10LR18		35QS10LR14	35QS10LR18	35QS10LR21				
	HOLLOW HOLLOW ALT.	17QS10H56	17QS10H14	23QS10H56	23QS10H14	23QS10H18		30QS10H14	30QS10H18		35QS10H14	35QS10H18	35QS10H21				
15	L	17QS15L56	17QS15L14	23QS15L56	23QS15L14			30QS15L14	30QS15L18		35QS15L14	35QS15L18					
	R	17QS15R56	17QS15R14	23QS15R56	23QS15R14			30QS15R14	30QS15R18		35QS15R14	35QS15R18					
	LR	17QS15LR56	17QS15LR14	23QS15LR56	23QS15LR14			30QS15LR14	30QS15LR18		35QS15LR14	35QS15LR18					
	HOLLOW HOLLOW ALT.	17QS15H56	17QS15H14	23QS15H56	23QS15H14			30QS15H14	30QS15H18		35QS15H14	35QS15H18					
20	L	17QS20L56	17QS20L14	23QS20L56	23QS20L14			30QS20L56	30QS20L14	30QS20L18		35QS20L14	35QS20L18				
	R	17QS20R56	17QS20R14	23QS20R56	23QS20R14			30QS20R56	30QS20R14	30QS20R18		35QS20R14	35QS20R18				
	LR	17QS20LR56	17QS20LR14	23QS20LR56	23QS20LR14			30QS20LR56	30QS20LR14	30QS20LR18		35QS20LR14	35QS20LR18				
	HOLLOW HOLLOW ALT.	17QS20H56	17QS20H14	23QS20H56	23QS20H14			30QS20H56	30QS20H14	30QS20H18		35QS20H14	35QS20H18				
25	L	17QS25L56		23QS25L56	23QS25L14			30QS25L56	30QS25L14	30QS25L18		35QS25L14	35QS25L18				
	R	17QS25R56		23QS25R56	23QS25R14			30QS25R56	30QS25R14	30QS25R18		35QS25R14	35QS25R18				
	LR	17QS25LR56		23QS25LR56	23QS25LR14			30QS25LR56	30QS25LR14	30QS25LR18		35QS25LR14	35QS25LR18				
	HOLLOW HOLLOW ALT.	17QS25H56		23QS25H56	23QS25H14			30QS25H56	30QS25H14	30QS25H18		35QS25H14	35QS25H18				
30	L	17QS30L56		23QS30L56	23QS30L14			30QS30L56	30QS30L14		35QS30L56	35QS30L14	35QS30L18				
	R	17QS30R56		23QS30R56	23QS30R14			30QS30R56	30QS30R14		35QS30R56	35QS30R14	35QS30R18				
	LR	17QS30LR56		23QS30LR56	23QS30LR14			30QS30LR56	30QS30LR14		35QS30LR56	35QS30LR14	35QS30LR18				
	HOLLOW HOLLOW ALT.	17QS30H56		23QS30H56	23QS30H14			30QS30H56	30QS30H14		35QS30H56	35QS30H14	35QS30H18				
40	L	17QS40L56		23QS40L56	23QS40L14			30QS40L56	30QS40L14		35QS40L56	35QS40L14	35QS40L18				
	R	17QS40R56		23QS40R56	23QS40R14			30QS40R56	30QS40R14		35QS40R56	35QS40R14	35QS40R18				
	LR	17QS40LR56		23QS40LR56	23QS40LR14			30QS40LR56	30QS40LR14		35QS40LR56	35QS40LR14	35QS40LR18				
	HOLLOW HOLLOW ALT.	17QS40H56		23QS40H56	23QS40H14			30QS40H56	30QS40H14		35QS40H56	35QS40H14	35QS40H18				
50	L	17QS50L56		23QS50L56				30QS50L56	30QS50L14		35QS50L56	35QS50L14					
	R	17QS50R56		23QS50R56				30QS50R56	30QS50R14		35QS50R56	35QS50R14					
	LR	17QS50LR56		23QS50LR56				30QS50LR56	30QS50LR14		35QS50LR56	35QS50LR14					
	HOLLOW HOLLOW ALT.	17QS50H56		23QS50H56				30QS50H56	30QS50H14		35QS50H56	35QS50H14					
60	L	17QS60L56		23QS60L56				30QS60L56	30QS60L14		35QS60L56	35QS60L14					
	R	17QS60R56		23QS60R56				30QS60R56	30QS60R14		35QS60R56	35QS60R14					
	LR	17QS60LR56		23QS60LR56				30QS60LR56	30QS60LR14		35QS60LR56	35QS60LR14					
	HOLLOW HOLLOW ALT.	17QS60H56		23QS60H56				30QS60H56	30QS60H14		35QS60H56	35QS60H14					

Note: Reducers are shipped without a mounting base. Order washdown bolt-on base kit from page G4-91 if required.

Additional washdown accessories available in Modifications / Accessories section of catalog.

Note: For reducer ratings and dimensions refer to Selection/Dimensions section of catalog.

FEATURES/BENEFITS PAGE G4-2	SPECIFICATION PAGE G4-8	NOMENCLATURE PAGE G4-9	MODIFICATION/ACCESSORIES PAGE G4-90
--------------------------------	----------------------------	---------------------------	--

TIGEAR-2 STAINLESS STEEL ULTRA KLEEN REDUCERS WITH 3-PIECE COUPLED INPUT

Available By June 2005

RATIO	SHAFT POSITION	SIZE-17		SIZE-23			SIZE-30			SIZE-35			
		56C	140TC	56C	140TC	180TC	56C	140TC	180TC	56C	140TC	180TC	210TC
		Part Number	Part Number	Part Number	Part Number	Part Number	Part Number	Part Number	Part Number	Part Number	Part Number	Part Number	Part Number
5	L	17AS05L56	17AS05L14	23AS05L56	23AS05L14	23AS05L18		30AS05L14	30AS05L18		35AS05L14	35AS05L18	35AS05L21
	R	17AS05R56	17AS05R14	23AS05R56	23AS05R14	23AS05R18		30AS05R14	30AS05R18		35AS05R14	35AS05R18	35AS05R21
	LR	17AS05LR56	17AS05LR14	23AS05LR56	23AS05LR14	23AS05LR18		30AS05LR14	30AS05LR18		35AS05LR14	35AS05LR18	35AS05LR21
	HOLLOW HOLLOW ALT.	17AS05H56	17AS05H14	23AS05H56	23AS05H14	23AS05H18		30AS05H14	30AS05H18		35AS05H14	35AS05H18	35AS05H21
7.5	L	17AS07L56	17AS07L14	23AS07L56	23AS07L14	23AS07L18		30AS07L14	30AS07L18		35AS07L14	35AS07L18	35AS07L21
	R	17AS07R56	17AS07R14	23AS07R56	23AS07R14	23AS07R18		30AS07R14	30AS07R18		35AS07R14	35AS07R18	35AS07R21
	LR	17AS07LR56	17AS07LR14	23AS07LR56	23AS07LR14	23AS07LR18		30AS07LR14	30AS07LR18		35AS07LR14	35AS07LR18	35AS07LR21
	HOLLOW HOLLOW ALT.	17AS07H56	17AS07H14	23AS07H56	23AS07H14	23AS07H18		30AS07H14	30AS07H18		35AS07H14	35AS07H18	35AS07H21
10	L	17AS10L56	17AS10L14	23AS10L56	23AS10L14	23AS10L18		30AS10L14	30AS10L18		35AS10L14	35AS10L18	35AS10L21
	R	17AS10R56	17AS10R14	23AS10R56	23AS10R14	23AS10R18		30AS10R14	30AS10R18		35AS10R14	35AS10R18	35AS10R21
	LR	17AS10LR56	17AS10LR14	23AS10LR56	23AS10LR14	23AS10LR18		30AS10LR14	30AS10LR18		35AS10LR14	35AS10LR18	35AS10LR21
	HOLLOW HOLLOW ALT.	17AS10H56	17AS10H14	23AS10H56	23AS10H14	23AS10H18		30AS10H14	30AS10H18		35AS10H14	35AS10H18	35AS10H21
15	L	17AS15L56	17AS15L14	23AS15L56	23AS15L14			30AS15L14	30AS15L18		35AS15L14	35AS15L18	
	R	17AS15R56	17AS15R14	23AS15R56	23AS15R14			30AS15R14	30AS15R18		35AS15R14	35AS15R18	
	LR	17AS15LR56	17AS15LR14	23AS15LR56	23AS15LR14			30AS15LR14	30AS15LR18		35AS15LR14	35AS15LR18	
	HOLLOW HOLLOW ALT.	17AS15H56	17AS15H14	23AS15H56	23AS15H14			30AS15H14	30AS15H18		35AS15H14	35AS15H18	
20	L	17AS20L56	17AS20L14	23AS20L56	23AS20L14		30AS20L56	30AS20L14	30AS20L18		35AS20L14	35AS20L18	
	R	17AS20R56	17AS20R14	23AS20R56	23AS20R14		30AS20R56	30AS20R14	30AS20R18		35AS20R14	35AS20R18	
	LR	17AS20LR56	17AS20LR14	23AS20LR56	23AS20LR14		30AS20LR56	30AS20LR14	30AS20LR18		35AS20LR14	35AS20LR18	
	HOLLOW HOLLOW ALT.	17AS20H56	17AS20H14	23AS20H56	23AS20H14		30AS20H56	30AS20H14	30AS20H18		35AS20H14	35AS20H18	
25	L	17AS25L56		23AS25L56	23AS25L14		30AS25L56	30AS25L14	30AS25L18		35AS25L14	35AS25L18	
	R	17AS25R56		23AS25R56	23AS25R14		30AS25R56	30AS25R14	30AS25R18		35AS25R14	35AS25R18	
	LR	17AS25LR56		23AS25LR56	23AS25LR14		30AS25LR56	30AS25LR14	30AS25LR18		35AS25LR14	35AS25LR18	
	HOLLOW HOLLOW ALT.	17AS25H56		23AS25H56	23AS25H14		30AS25H56	30AS25H14	30AS25H18		35AS25H14	35AS25H18	
30	L	17AS30L56		23AS30L56	23AS30L14		30AS30L56	30AS30L14		35AS30L56	35AS30L14	35AS30L18	
	R	17AS30R56		23AS30R56	23AS30R14		30AS30R56	30AS30R14		35AS30R56	35AS30R14	35AS30R18	
	LR	17AS30LR56		23AS30LR56	23AS30LR14		30AS30LR56	30AS30LR14		35AS30LR56	35AS30LR14	35AS30LR18	
	HOLLOW HOLLOW ALT.	17AS30H56		23AS30H56	23AS30H14		30AS30H56	30AS30H14		35AS30H56	35AS30H14	35AS30H18	
40	L	17AS40L56		23AS40L56	23AS40L14		30AS40L56	30AS40L14		35AS40L56	35AS40L14	35AS40L18	
	R	17AS40R56		23AS40R56	23AS40R14		30AS40R56	30AS40R14		35AS40R56	35AS40R14	35AS40R18	
	LR	17AS40LR56		23AS40LR56	23AS40LR14		30AS40LR56	30AS40LR14		35AS40LR56	35AS40LR14	35AS40LR18	
	HOLLOW HOLLOW ALT.	17AS40H56		23AS40H56	23AS40H14		30AS40H56	30AS40H14		35AS40H56	35AS40H14	35AS40H18	
50	L	17AS50L56		23AS50L56			30AS50L56	30AS50L14		35AS50L56	35AS50L14		
	R	17AS50R56		23AS50R56			30AS50R56	30AS50R14		35AS50R56	35AS50R14		
	LR	17AS50LR56		23AS50LR56			30AS50LR56	30AS50LR14		35AS50LR56	35AS50LR14		
	HOLLOW HOLLOW ALT.	17AS50H56		23AS50H56			30AS50H56	30AS50H14		35AS50H56	35AS50H14		
60	L	17AS60L56		23AS60L56			30AS60L56	30AS60L14		35AS60L56	35AS60L14		
	R	17AS60R56		23AS60R56			30AS60R56	30AS60R14		35AS60R56	35AS60R14		
	LR	17AS60LR56		23AS60LR56			30AS60LR56	30AS60LR14		35AS60LR56	35AS60LR14		
	HOLLOW HOLLOW ALT.	17AS60H56		23AS60H56			30AS60H56	30AS60H14		35AS60H56	35AS60H14		

Note: Reducers are shipped without a mounting base. Order washdown bolt-on base kit from page G4-91 if required.

Additional washdown accessories available in Modifications / Accessories section of catalog.

Note: For reducer ratings and dimensions refer to Selection/Dimensions section of catalog.

FEATURES/BENEFITS PAGE G4-2	SPECIFICATION PAGE G4-8	NOMENCLATURE PAGE G4-9	MODIFICATION/ACCESSORIES PAGE G4-90
--------------------------------	----------------------------	---------------------------	--

HELICAL ATTACHMENT



TIGEAR-2 Helical Attachment

QUICK SELECTIONS: HELICAL ATTACHMENT AND TIGEAR-2 ASSEMBLIES

Input HP	Overall Ratio	Output RPM	Output Torque	Output HP	Helical Ratio	Tigear-2 Unit Size	Tigear-2 Ratio	NEMA Motor	S.F.	Helix Unit Part Number	Tigear-2 Part Number Output Shaft Configuration			
											Solid Shaft Left	Solid Shaft Right	Solid Shaft Left/Right	Hollow Shaft
0.25	75	23.33	563	0.21	5	17	15	56	1.13	561HA556	17Q15L56	17Q15R56	17Q15LR56	17Q15H56
	80	21.88	573	0.2	4	17	20	56	1.15	561HA456	17Q20L56	17Q20R56	17Q20LR56	17Q20H56
	100	17.5	957	0.27	5	20	20	56	1.35	561HA556	20Q20L56	20Q20R56	20Q20LR56	20Q20H56
	120	14.58	807	0.19	4	20	30	56	1.21	561HA456	20Q30L56	20Q30R56	20Q30LR56	20Q30H56
	125	14	862	0.19	5	20	25	56	1.15	561HA556	20Q25L56	20Q25R56	20Q25LR56	20Q25H56
	150	11.67	1349	0.25	5	23	30	56	1.48	561HA556	23Q30L56	23Q30R56	23Q30LR56	23Q30H56
	160	10.94	1329	0.23	4	23	40	56	1.5	561HA456	23Q40L56	23Q40R56	23Q40LR56	23Q40H56
	200	8.75	1258	0.17	5	23	40	56	1.2	561HA556	23Q40L56	23Q40R56	23Q40LR56	23Q40H56
	240	7.29	1300	0.15	4	23	60	56	1.07	561HA456	23Q60L56	23Q60R56	23Q60LR56	23Q60H56
	250	7	1960	0.22	5	26	50	56	1.48	561HA556	26Q50L56	26Q50R56	26Q50LR56	26Q50H56
0.33	300	5.83	1678	0.16	5	26	60	56	1.24	561HA556	26Q60L56	26Q60R56	26Q60LR56	26Q60H56
	75	23.33	752	0.28	5	20	15	56	1.26	561HA556	20Q15L56	20Q15R56	20Q15LR56	20Q15H56
	80	21.88	766	0.27	4	20	20	56	1.28	561HA456	20Q20L56	20Q20R56	20Q20LR56	20Q20H56
	100	17.5	957	0.27	5	20	20	56	1.02	561HA556	20Q20L56	20Q20R56	20Q20LR56	20Q20H56
	120	14.58	1079	0.25	4	23	30	56	1.4	561HA456	23Q30L56	23Q30R56	23Q30LR56	23Q30H56
	125	14	1138	0.25	5	23	25	56	1.36	561HA556	23Q25L56	23Q25R56	23Q25LR56	23Q25H56
	150	11.67	1349	0.25	5	23	30	56	1.12	561HA556	23Q30L56	23Q30R56	23Q30LR56	23Q30H56
	160	10.94	1329	0.23	4	23	40	56	1.14	561HA456	23Q40L56	23Q40R56	23Q40LR56	23Q40H56
	200	8.75	1707	0.24	5	26	40	56	1.32	561HA556	26Q40L56	26Q40R56	26Q40LR56	26Q40H56
	240	7.29	1772	0.21	4	26	60	56	1.17	561HA456	26Q60L56	26Q60R56	26Q60LR56	26Q60H56
0.5	250	7	1960	0.22	5	26	50	56	1.12	561HA556	26Q50L56	26Q50R56	26Q50LR56	26Q50H56
	300	5.83	2215	0.21	5	30	60	56	1.28	561HA556	30Q60L56	30Q60R56	30Q60LR56	30Q60H56
	75	23.33	1140	0.42	5	23	15	56	1.29	561HA556	23Q15L56	23Q15R56	23Q15LR56	23Q15H56
	80	21.88	1175	0.41	4	23	20	56	1.3	561HA456	23Q20L56	23Q20R56	23Q20LR56	23Q20H56
	100	17.5	1468	0.41	5	23	20	56	1.04	561HA556	23Q20L56	23Q20R56	23Q20LR56	23Q20H56
	120	14.58	1656	0.38	4	26	30	56	1.36	561HA456	26Q30L56	26Q30R56	26Q30LR56	26Q30H56
	125	14	1769	0.39	5	26	25	56	1.31	561HA556	26Q25L56	26Q25R56	26Q25LR56	26Q25H56
	150	11.67	2070	0.38	5	26	30	56	1.09	561HA556	26Q30L56	26Q30R56	26Q30LR56	26Q30H56
	160	10.94	2070	0.36	4	26	40	56	1.09	561HA456	26Q40L56	26Q40R56	26Q40LR56	26Q40H56
	200	8.75	2587	0.36	5	30	40	56	1.37	561HA556	30Q40L56	30Q40R56	30Q40LR56	30Q40H56
0.75	240	7.29	2685	0.31	4	30	60	56	1.05	561HA456	30Q60L56	30Q60R56	30Q60LR56	30Q60H56
	250	7	2969	0.33	5	30	50	56	1.11	561HA556	30Q50L56	30Q50R56	30Q50LR56	30Q50H56
	300	5.83	3356	0.31	5	35	60	56	1.27	561HA556	35Q60L56	35Q60R56	35Q60LR56	35Q60H56
	75	23.33	1729	0.64	5	26	15	56	1.27	561HA556	26Q15L56	26Q15R56	26Q15LR56	26Q15H56
	80	21.88	1783	0.62	4	26	20	56	1.28	561HA456	26Q20L56	26Q20R56	26Q20LR56	26Q20H56
	100	17.5	2229	0.62	5	26	20	56	1.02	561HA556	26Q20L56	26Q20R56	26Q20LR56	26Q20H56
	120	14.58	2484	0.57	4	30	30	56	1.29	561HA456	30Q30L56	30Q30R56	30Q30LR56	30Q30H56
	125	14	2654	0.59	5	30	25	56	1.24	561HA556	30Q25L56	30Q25R56	30Q25LR56	30Q25H56
	150	11.67	3105	0.57	5	30	30	56	1.03	561HA556	30Q30L56	30Q30R56	30Q30LR56	30Q30H56
	160	10.94	3104	0.54	4	30	40	56	1.14	561HA456	30Q40L56	30Q40R56	30Q40LR56	30Q40H56
1	200	8.75	4751	0.66	4	35	50	56	1.27	561HA456	35Q50L56	35Q50R56	35Q50LR56	35Q50H56
	240	7.29	4028	0.47	4	35	60	56	1.15	561HA456	35Q60L56	35Q60R56	35Q60LR56	35Q60H56
	250	7	4454	0.49	5	35	50	56	1.13	561HA556	35Q50L56	35Q50R56	35Q50LR56	35Q50H56
	300	5.83	5035	0.47	4	40	60	56	1.16	561HA456	40Q60L56	40Q60R56	40Q60LR56	40Q60H56
	75	23.33	2306	0.85	5	30	15	56	1.39	561HA556	30Q15L56	30Q15R56	30Q15LR56	30Q15H56
	80	21.88	2377	0.83	4	30	20	56	1.5	561HA456	30Q20L56	30Q20R56	30Q20LR56	30Q20H56
	100	17.5	2972	0.83	5	30	20	56	1.2	561HA556	30Q20L56	30Q20R56	30Q20LR56	30Q20H56
	120	14.58	4968	1.15	4	35	30	56	1.41	561HA456	35Q30L56	35Q30R56	35Q30LR56	35Q30H56
	125	14	3538	0.79	5	35	25	56	1.3	561HA556	35Q25L56	35Q25R56	35Q25LR56	35Q25H56
	150	11.67	4140	0.77	5	35	30	56	1.26	561HA556	35Q30L56	35Q30R56	35Q30LR56	35Q30H56
1.5	160	10.94	4139	0.72	4	35	40	56	1.17	561HA456	35Q40L56	35Q40R56	35Q40LR56	35Q40H56
	200	8.75	5174	0.72	5	35	40	56	1.02	561HA556	35Q40L56	35Q40R56	35Q40LR56	35Q40H56
	240	7.29	5370	0.62	4	40	60	56	1	561HA456	40Q60L56	40Q60R56	40Q60LR56	40Q60H56
	250	7	5938	0.66	4	40	50	56	1	561HA456	40Q50L56	40Q50R56	40Q50LR56	40Q50H56
	75	23.33	3458	1.28	5	35	15	56	1.27	561HA556	35Q15L56	35Q15R56	35Q15LR56	35Q15H56
	80	21.88	3566	1.24	4	35	20	56	1.23	561HA456	35Q20L56	35Q20R56	35Q20LR56	35Q20H56
	100	17.5	4458	1.24	5	35	20	56	1.02	561HA556	35Q20L56	35Q20R56	35Q20LR56	35Q20H56
	150	11.67	6682	1.24	5	47	30	56	1.02	561HA556	47Q30L56	47Q30R56	47Q30LR56	47Q30H56
	160	10.94	6709	1.16	4	47	40	56	0.97	561HA456	47Q40L56	47Q40R56	47Q40LR56	47Q40H56

NOTES: (1) If 3-Piece Coupled input is preferred, replace the "Q" in the TIGEAR-2 part number with "A". For example: 26Q15L56 would become 26A15L56.

(2) These units are not available with Quill inputs

 Backdrivable

FEATURES/BENEFITS PAGE G4-2	SPECIFICATION PAGE G4-8	NOMENCLATURE PAGE G4-9	MODIFICATION/ACCESSORIES PAGE G4-90
--------------------------------	----------------------------	---------------------------	--

HELICAL ATTACHMENT



TIGEAR-2 Helical Attachment SIZE 1 HELICAL SINGLE REDUCTION NEMA 56C INPUT, NEMA 56C OUTPUT

Size	Ratio	Part Number	Input RPM	Output RPM	Input HP	Output HP	Output Torque (lb. in.)	Output OHL (lbs.)
1	4	561HA456	1750	440	1.5	1.47	211	397
1	5	561HA556	1750	350	1.5	1.47	265	410

Note: For Helical attachment, DODDGE recommends the use of TEFC motors

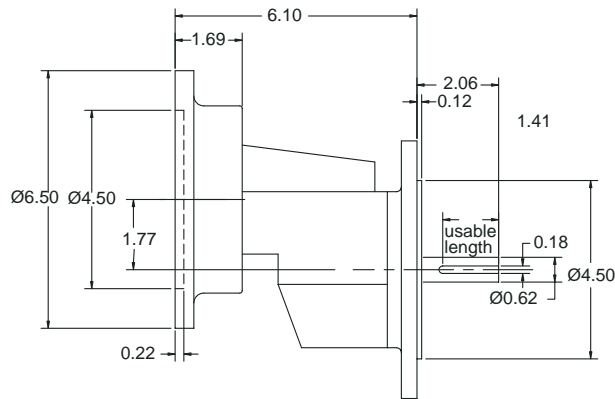

Ø0.43 8-HOLES EQ. SPACED AS SHOWN ON Ø5.875 B.C.

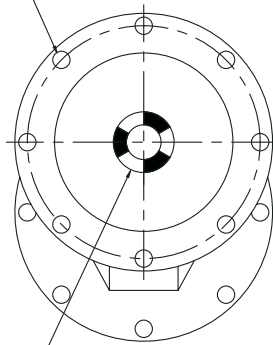

Integral Coupling Half for NEMA 56C Motor Shaft (Motor Coupling Half and Spider are Supplied With The Helical Unit)

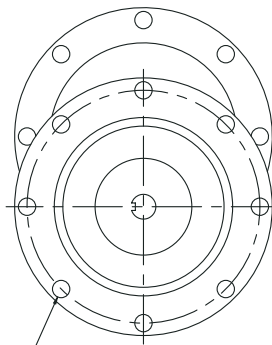

Ø0.43 8-HOLES EQ. SPACED AS SHOWN ON Ø5.875 B.C.

FEATURES/BENEFITS PAGE G4-2	SPECIFICATION PAGE G4-8	NOMENCLATURE PAGE G4-9	MODIFICATION/ACCESSORIES PAGE G4-90
--------------------------------	----------------------------	---------------------------	--



MOUNTING POSITIONS

TIGEAR-2 Mounting Positions

TIGEAR-2 reducers are supplied with a high performance lubricant factory filled to a level suitable for all approved mounting positions. Positions shown as not recommended do NOT void the product warrant. They are however, positions that can cause problems in certain applications. Mounting position nomenclature is NOT required when ordering. Mounting positions apply to all input and output configurations.

Floor Mounted,
Motor Adapter Or Input Shaft Above The Output Shaft

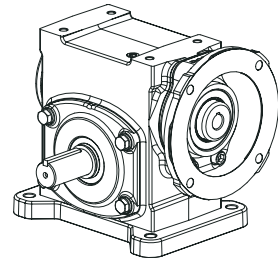

Wall Mounted,
Motor Adapter Or Input Shaft Facing Down
NOT RECOMMENDED

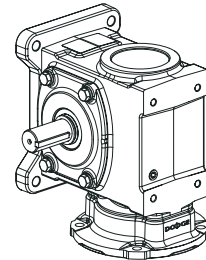

Ceiling Mounted,
Motor, Motor Adapter Or Input Shaft Above The Output Shaft

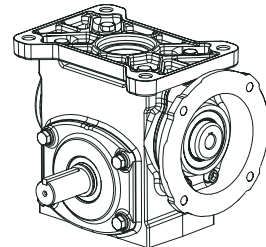

Wall Mounted,
Motor Adapter Or Input Shaft Facing Up

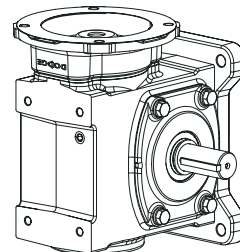

MOUNTING POSITIONS



TIGEAR-2 Mounting Positions

Wall Mounted,
Output Shaft Down

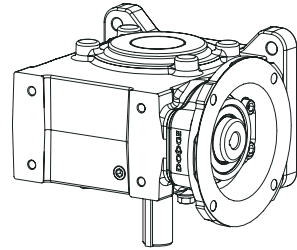

Wall Mounted,
Output Shaft Up

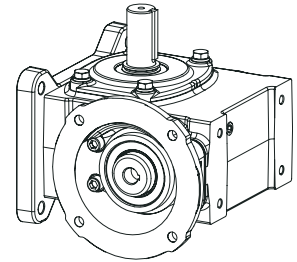

Floor Or Ceiling Mounted
Motor Adapter Or Input Shaft Below Output Shaft
NOT RECOMMENDED

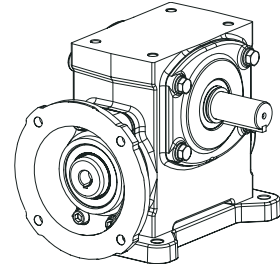

FEATURES/BENEFITS PAGE G4-2	SPECIFICATION PAGE G4-8	NOMENCLATURE PAGE G4-9	MODIFICATION ACCESSORIES PAGE G4-90
--------------------------------	----------------------------	---------------------------	--

MODIFICATIONS/ACCESSORIES



TIGEAR-2 MOTOR ADAPTER KIT

TIGEAR-2 motor adapter kits are available to convert a separate shaft input reducer to a three-piece coupled input reducer. Kits listed at right include the motor adapter housing, three-piece coupling and all required mounting hardware.

TIGEAR-2 motor adapter kits cannot be used with the old Adaptable or Separate series TIGEAR reducers.

REDUCER SIZE	MOTOR FRAME				
	56C	140TC	180TC	210TC	250TC
13	1315MTR56	1315MTR14	N/A	N/A	N/A
15	1315MTR56	1315MTR14	N/A	N/A	N/A
17	1720MTR56	1720MTR14	N/A	N/A	N/A
20	1720MTR56	1720MTR14	N/A	N/A	N/A
23	2330MTR56	2330MTR14	2330MTR18	N/A	N/A
26	2330MTR56	2330MTR14	2330MTR18	N/A	N/A
30	2330MTR56	2330MTR14	2330MTR18	N/A	N/A
35	35MTR56	35MTR14	35MTR18	35MTR21	N/A
40	N/A	4047MTR14	4047MTR18	4047MTR21	4047MTR25
47	N/A	4047MTR14	4047MTR18	4047MTR21	4047MTR25



TIGEAR-2 BOLT-ON BASE KIT

All TIGEAR-2 reducers include top and bottom drilled and tapped mounting holes but do not include base. Each kit below includes the base and required mounting hardware.

Reducer Size	Standard Kit Number	Standard Spacer Kit Number ⁽¹⁾	E-Z KLEEN Kit Number	Stainless Steel ULTRA KLEEN Kit
13	13BASE	Not Required	13ZBASE	not available
15	15BASE	Not Required	15ZBASE	not available
17	17BASE	Not Required	17ZBASE	17SBASE
20	20BASE	Not Required	20ZBASE	not available
23 ⁽¹⁾	23BASE	2326SPACER	23ZBASE	23SBASE
26 ⁽¹⁾	26BASE	2326SPACER	26ZBASE	not available
30 ⁽¹⁾	30BASE	3035SPACER	30ZBASE	30SBASE
35 ⁽¹⁾	35BASE	3035SPACER	35ZBASE	35SBASE
40 ⁽¹⁾	40BASE	40SPACER	not available	not available
47	47BASE	Not Required	not available	not available

Note: Sizes 17 and 20 have slotted mounting holes

(1) If base is to be mounted on top of reducer, spacer kit listed above will also be required to allow clearance of base and motor adapter housing. Currently not available with E-Z KLEEN coating or stainless steel material.

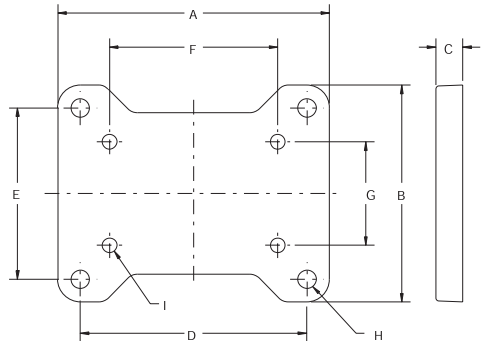

SIZE	A	B	C	D	E	F	G	H	I
13	5.25	4.19	0.52	4.38	3.31	3.25	2	0.34	0.28
15	6.13	5.19	0.61	5.25	4.31	3.5	2.25	0.44	0.28
17	6.94	5.56	0.74	5.88	4.50	4.19	2.75	0.41	0.34
20	7.26	5.66	0.74	6.20	4.60	5.00	2.88	0.50	0.41
23	8.32	6.14	0.75	7.06	4.88	5.00	2.88	0.47	0.41
26	9.25	6.50	0.79	8.00	5.25	6.38	3.38	0.56	0.41
30	9.68	7.12	0.75	8.44	5.88	7.00	4.00	0.53	0.49
35	10.75	7.38	1.00	9.50	6.13	7.50	4.00	0.58	0.47
40	12.62	9.13	1.00	11.12	7.63	8.50	5.00	0.66	0.66
47	16.00	10.26	1.13	14.12	8.38	11.00	5.81	0.78	0.66

FEATURES/BENEFITS PAGE G4-2	SPECIFICATION PAGE G4-8	NOMENCLATURE PAGE G4-9	SELECTION/DIMENSIONS PAGE G4-16
--------------------------------	----------------------------	---------------------------	------------------------------------

MODIFICATIONS/ACCESSORIES



TIGEAR-2 J-MOUNT BASE KITS

J-mount kits allow the reducer to be “floor” mounted with the motor in a vertical (up) position. In this configuration the output shaft(s) is horizontal. Each kit includes the brackets and required mounting hardware.

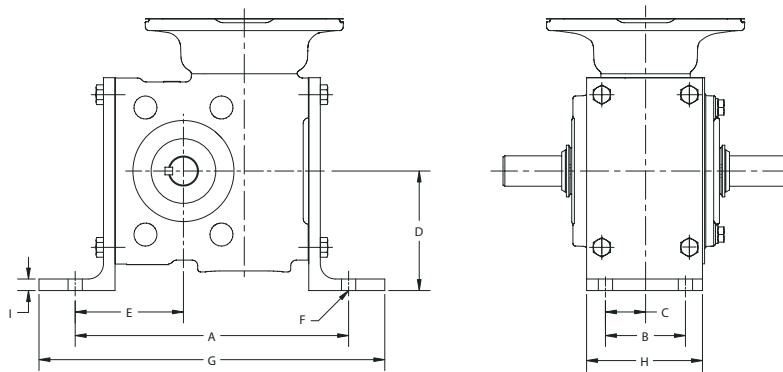

Reducer Size	Standard Kit Number	E-Z KLEEN Kit Number	A	B	C	D	E	F	G	H	I
13	13JMOUNT	13ZJMOUNT	6.88	2.00	1.00	2.95	2.71	0.34	7.76	2.88	0.25
15	15JMOUNT	15ZJMOUNT	7.98	2.50	1.25	3.50	3.12	0.41	9.48	3.38	0.31
17	17JMOUNT	17ZJMOUNT	8.35	2.50	1.25	3.50	3.24	0.41	9.85	3.56	0.38
20	20JMOUNT	20ZJMOUNT	8.97	2.63	1.32	3.94	3.55	0.47	11.35	3.75	0.38
23	23JMOUNT	23ZJMOUNT	9.88	2.88	1.44	4.06	3.75	0.50	10.88	4.12	0.38
26	26JMOUNT	26ZJMOUNT	11.48	3.13	1.57	4.75	4.43	0.53	13.36	4.25	0.50
30	30JMOUNT	30ZJMOUNT	11.88	4.00	2.00	5.62	4.75	0.56	13.02	5.06	0.38
35	35JMOUNT	35ZJMOUNT	13.50	4.00	2.00	5.50	5.45	0.56	15.57	5.50	0.38
40	40JMOUNT	not available	14.88	5.00	2.50	6.50	6.12	0.69	16.26	6.38	0.50
47	47JMOUNT	not available	17.51	5.81	2.91	7.75	7.19	0.69	18.89	7.19	0.50

TIGEAR-2 RISER BLOCK KITS

Riser blocks allow clearance over the motor eliminating the need to invert the reducer (worm under) when the application calls for a “ceiling” mount such as under a conveyor or other equipment. Riser blocks permit the reducer to be mounted in the most desirable position keeping the high speed shaft seal above the oil level. Experience shows that this position results in increased seal life and durability. Each kit includes the riser block and required mounting hardware.

Reducer Size	Standard Kit Number	E-Z KLEEN Kit Number	A	B
13	13RISER	13ZRISER	1.66	5.36
15	15RISER	15ZRISER	1.38	5.61
17	17RISER	17ZRISER	1.38	5.99
20	20RISER	20ZRISER	1.38	6.24
23	23RISER	23ZRISER	2.25	7.88
26	26RISER	26ZRISER	1.91	8.21
30	30RISER	30ZRISER	2.25	8.63
35	35RISER	35ZRISER	1.69	9.27
40	40RISER	not available	2.75	10.83
47	47RISER	not available	2.00	11.57

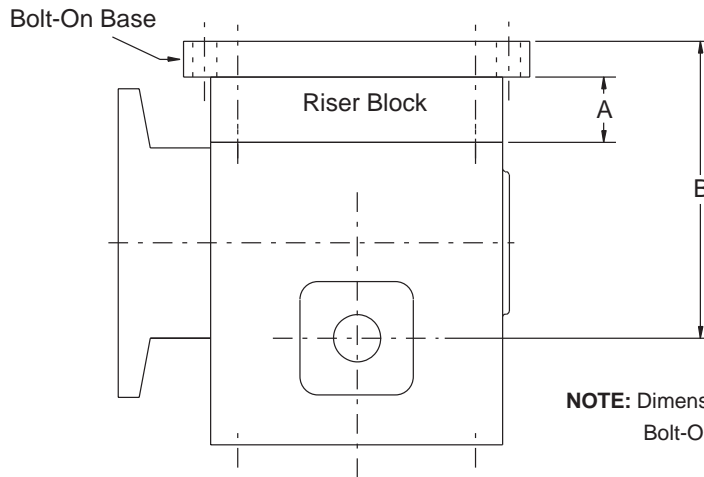

NOTE: Dimension B includes optional Bolt-On Base

FEATURES/BENEFITS PAGE G4-2	SPECIFICATION PAGE G4-8	NOMENCLATURE PAGE G4-9	SELECTION/DIMENSIONS PAGE G4-16
--------------------------------	----------------------------	---------------------------	------------------------------------

MODIFICATIONS/ACCESSORIES

TIGEAR-2 TIE ROD KIT

Tie Rod Kits are available for restraining Hollow Shaft Reducers. Each kit includes reducer mounting bracket, tie rods, turnbuckle, fulcrum and mounting hardware.

Reducer Case Size	Tie Rod Kit	Reducer Case Size	Tie Rod Kit
13	13TIEROD	26	26TIEROD
15	15TIEROD	30	30TIEROD
17	17TIEROD	35	35TIEROD
20	2023TIEROD	40	40TIEROD
23		47	47TIEROD

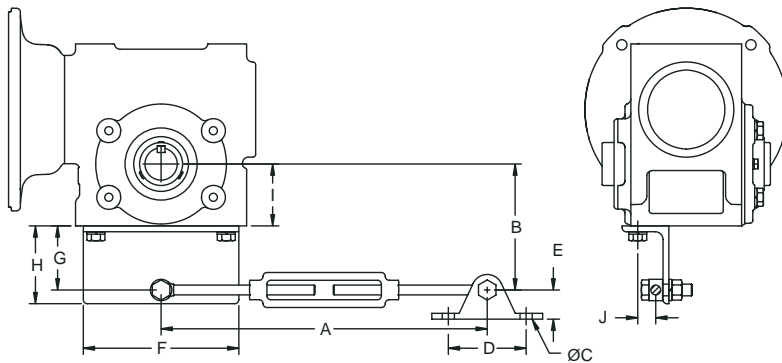

Size	A MIN - MAX	B	C	D	E	F	G	H	I	J
13	12.00 - 18.00	2.52	.041	1.75	0.75	4.00	0.81	1.25	1.71	0.37
15	12.00 - 18.00	2.68	0.41	1.75	0.75	4.20	0.81	1.25	1.87	0.49
17	12.00 - 18.00	4.05	0.41	1.75	0.75	5.00	2.06	2.50	1.99	0.59
20	14.7 - 17.7	3.55	0.39	2.50	0.94	5.88	1.31	1.75	2.24	0.53
23	14.7 - 17.7	3.81	0.39	2.50	0.94	5.88	1.31	1.75	2.50	0.53
26	14.7 - 17.7	4.18	0.39	2.50	0.94	7.24	1.31	1.75	2.87	0.75
30	14.7 - 17.7	5.75	0.39	2.50	0.94	8.00	2.50	3.00	3.25	0.72
35	14.7 - 17.7	6.49	0.39	2.50	0.94	8.50	2.50	3.00	3.99	0.84
40	19.5 - 25.5	7.69	0.45	3.00	1.06	9.88	3.25	4.00	4.44	1.09
47	19.5 - 25.5	9.56	0.45	3.00	1.06	12.38	4.25	5.00	5.31	1.03

TIGEAR-2 CAST OUTPUT FLANGE KIT

The Output Cast Flange Kit is used to mount Hollow Shaft reducers to a flat surface perpendicular to the output shaft. The flange may be substituted for a tie rod kit to restrain reactions. Each kit consists of a flange and required mounting hardware. The Output Flange kit can be mounted to either side of a hollow output reducer. When used with GRIP TIGHT bushings, a single bushing with key must be used and located on the side opposite of the cast output flange.

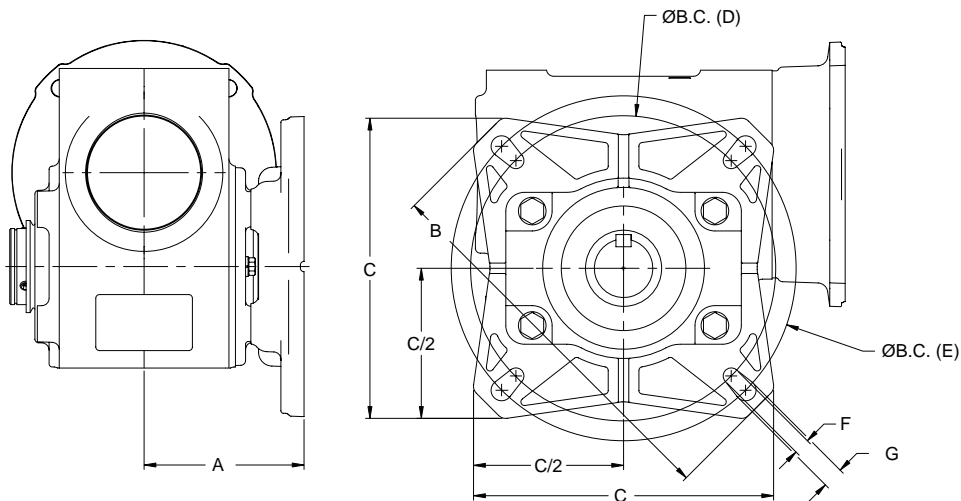

CASE SIZE	Standard Kit Number	E-Z KLEEN Kit Number	Stainless Steel ULTRA KLEEN Kit	A	B	C	ØB.C. (D)	Ø B.C. (E)	F	G
13, 15	not available	not available	not available							
17	17FLANGE	17ZFLANGE	17SFLANGE	3.58	8.00	6.24	5.88	7.00	0.34	0.41
20	20FLANGE	20ZFLANGE	not available	3.68	8.00	6.24	5.88	7.00	0.34	0.41
23,26	2326FLANGE	2326ZFLANGE	23SFLANGE	3.94 / 4.03	9.60	7.52	7.50	8.47	0.41	0.51
30,35	3035FLANGE	3035ZFLANGE	3035SFLANGE	5.81 / 5.71	11.60	9.00	9.00	10.43	0.56	0.56
40, 47	not available	not available	not available							

FEATURES/BENEFITS PAGE G4-2	SPECIFICATION PAGE G4-8	NOMENCLATURE PAGE G4-9	SELECTION/DIMENSIONS PAGE G4-16
--------------------------------	----------------------------	---------------------------	------------------------------------

MODIFICATIONS/ACCESSORIES



TIGEAR-2 HOLLOW REDUCER BUSHING KITS

Bushing kits allow hollow output reducers to be mounted to various diameter shafting. Each kit includes bushing and key.

Reducer Size	Max Bore	Bore Size	Standard		Stainless Steel	
			GRIP TIGHT*	Straight Bore	GRIP TIGHT*	Straight Bore
13	3/4"	n/a	n/a	n/a	n/a	n/a
15	3/4"	n/a	n/a	n/a	n/a	n/a
17	1"	n/a	n/a	n/a	n/a	n/a

20	1-1/4"	1"	n/a	20BUSH100		20SBUSH100
Select standard bore reducer model number from pages G4-36 to G4-41 or washdown reducers from pages G4-80-G4-85.						

20 Alt.	1-3/16"	n/a	n/a			n/a
Select alternative max bore reducer model number from page G4-97 or washdown reducers from pages G4-80-G4-85.						

23	1-7/16"	1"	n/a	2326BUSH100		2326SBUSH100
		1-3/16"	n/a	2326BUSH103		2326SBUSH103
		1-1/4"	n/a	2326BUSH104		2326SBUSH104
Select standard bore reducer model number from pages 42 to 47 or washdown reducers from pages G4-80-G4-85.						

23 Alt	1-1/2"	1"	23TBUSH100	n/a	23STBUSH100	n/a
		1-3/16"	23TBUSH103	n/a	23STBUSH103	n/a
Select alternative max bore reducer model number from page G4-97 or washdown reducers from pages G4-80-G4-85.						

26	1-7/16"	1"	n/a	2326BUSH100		2326SBUSH100
		1-3/16"	n/a	2326BUSH103		2326SBUSH103
		1-1/4"	n/a	2326BUSH104		2326SBUSH104
Select standard bore reducer model number from pages G4-50 to G4-55 or washdown reducers from pages G4-80-G4-85.						

26 Alt	1-11/16" ^{mm}	1"	26TBUSH100	n/a	26STBUSH100	n/a
		1-3/16"	26TBUSH103	n/a	26STBUSH103	n/a
		1-1/4"	26TBUSH104	n/a	26STBUSH104	n/a
		1-3/8"	26TBUSH106	n/a	26STBUSH106	n/a
Select alternative max bore reducer model number from page G4-97 or washdown reducers from pages G4-80-G4-85.						

30	1-15/16"	1-3/8"	3035TBUSH106	n/a	3035STBUSH106	n/a
		1-7/16"	3035TBUSH107	n/a	3035STBUSH107	n/a
		1-1/2"	3035TBUSH108	n/a	3035STBUSH108	n/a
		1-11/16"	n/a	3035BUSH111		3035SBUSH111
Select standard bore reducer model number from pages G4-56 to G4-61 or washdown reducer from pages G4-80-G4-85.						

35	1-15/16"	1-3/8"	3035TBUSH106	n/a	3035STBUSH106	n/a
		1-7/16"	3035TBUSH107	n/a	3035STBUSH107	n/a
		1-1/2"	3035TBUSH108	n/a	3035STBUSH108	n/a
		1-11/16"		3035BUSH111		3035SBUSH111
Select standard bore reducer model number from pages G4-62 to G4-67 or washdown reducers from pages G4-80-G4-85.						

40	2-3/16"	1-1/2"	40TBUSH108	n/a	n/a	n/a
		1-11/16"	40TBUSH111	n/a	n/a	n/a
Select standard bore reducer model number from pages G4-68 to G4-73 or washdown reducers from pages G4-80-G4-85.						

47	2-15/16"	1-15/16"	47TBUSH115	n/a	n/a	n/a
		2-3/16"	47TBUSH203	n/a	n/a	n/a
Select standard bore reducer model number from pages G4-74 to G4-79 or washdown reducers from pages G4-80-G4-85.						

* Required shaft diameter tolerance for GRIP TIGHT bushings: +.000", -.003"



GRIP TIGHT Tapered Adapter Bushing Kit



Straight Bore Bushing Kit

FEATURES/BENEFITS PAGE G4-2	SPECIFICATION PAGE G4-8	NOMENCLATURE PAGE G4-9	SELECTION/DIMENSIONS PAGE G4-16
--------------------------------	----------------------------	---------------------------	------------------------------------

TIGEAR-2 HOLLOW REDUCERS WITH ALTERNATIVE MAXIMUM BORE

Size 20 Hollow Reducer Part Numbers with Alternative Maximum Bore (1-3/16")

Input	Motor Frame	Ratio									
		5	7.5	10	15	20	25	30	40	50	60
Quill	56C	20Q05HA56	20Q07HA56	20Q10HA56	20Q15HA56	20Q20HA56	20Q25HA56	20Q30HA56	20Q40HA56	20Q50HA56	20Q60HA56
	140TC	20Q05HA14	20Q07HA14	20Q10HA14	20Q15HA14	20Q20HA14	20Q25HA14				
Separate	Select Motor Adapter Kit as Needed	20S05HA	20S07HA	20S10HA	20S15HA	20S20HA	20S25HA	20S30HA	20S40HA	20S50HA	20S60HA
Coupled Assy	56C	20A05HA56	20A07HA56	20A10HA56	20A15HA56	20A20HA56	20A25HA56	20A30HA56	20A40HA56	20A50HA56	20A60HA56
	140TC	20A05HA14	20A07HA14	20A10HA14	20A15HA14	20A20HA14	20A25HA14				

Note: Tapered bushing kits are not available for size 20

Size 23 Hollow Reducer Part Numbers with Alternative Maximum Bore (1-1/2")

Input	Motor Frame	Ratio									
		5	7.5	10	15	20	25	30	40	50	60
Quill	56C	23Q05HA56	23Q07HA56	23Q10HA56	23Q15HA56	23Q20HA56	23Q25HA56	23Q30HA56	23Q40HA56	23Q50HA56	23Q60HA56
	140TC	23Q05HA14	23Q07HA14	23Q10HA14	23Q15HA14	23Q20HA14	23Q25HA14	23Q30HA14	23Q40HA14		
	180TC	23Q05HA18	23Q07HA18	23Q10HA18							
Separate	Select Motor Adapter Kit as Needed	23S05HA	23S07HA	23S10HA	23S15HA	23S20HA	23S25HA	23S30HA	23S40HA	23S50HA	23S60HA
Coupled Assy	56C	23A05HA56	23A07HA56	23A10HA56	23A15HA56	23A20HA56	23A25HA56	23A30HA56	23A40HA56	23A50HA56	23A60HA56
	140TC	23A05HA14	23A07HA14	23A10HA14	23A15HA14	23A20HA14	23A25HA14	23A30HA14	23A40HA14		
	180TC	23A05HA18	23A07HA18	23A10HA18							

Note: These reducers are required when using tapered bushing kits for size 23

Size 26 Hollow Reducer Part Numbers with Alternative Maximum Bore (1-11/16")

Input	Motor Frame	Ratio									
		5	7.5	10	15	20	25	30	40	50	60
Quill	56C		26Q07HA56	26Q10HA56	26Q15HA56	26Q20HA56	26Q25HA56	26Q30HA56	26Q40HA56	26Q50HA56	26Q60HA56
	140TC	26Q05HA14	26Q07HA14	26Q10HA14	26Q15HA14	26Q20HA14	26Q25HA14	26Q30HA14	26Q40HA14	26Q50HA14	26Q60HA14
	180TC	26Q05HA18	26Q07HA18	26Q10HA18	26Q15HA18						
Separate	Select Motor Adapter Kit as Needed	26S05HA	26S07HA	26S10HA	26S15HA	26S20HA	26S25HA	26S30HA	26S40HA	26S50HA	26S60HA
Coupled Assy	56C		26A07HA56	26A10HA56	26A15HA56	26A20HA56	26A25HA56	26A30HA56	26A40HA56	26A50HA56	26A60HA56
	140TC	26A05HA14	26A07HA14	26A10HA14	26A15HA14	26A20HA14	26A25HA14	26A30HA14	26A40HA14	26A50HA14	26A60HA14
	180TC	26A05HA18	26A07HA18	26A10HA18	26A15HA18						

Note: These reducers are required when using tapered bushing kits for size 26

FEATURES/BENEFITS PAGE G4-2	SPECIFICATION PAGE G4-8	NOMENCLATURE PAGE G4-9	SELECTION/DIMENSIONS PAGE G4-16
--------------------------------	----------------------------	---------------------------	------------------------------------

MODIFICATIONS/ACCESSORIES



TIGEAR-2 TAPERED BUSHING DIMENSIONS

SINGLE BUSHING WITH KEY

Bushing Located On Side Of Reducer Closest To Driven Device

This is the Preferred mounting method for single bushing applications

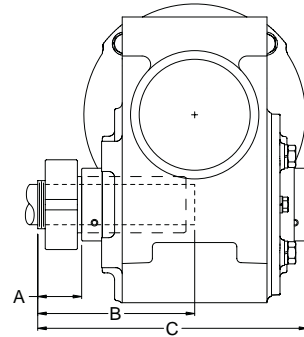

REDUCER SIZE	DRIVEN SHAFT DIAMETER	A DISTANCE FROM END OF BUSHING TO END OF HOLLOW SHAFT	B DISTANCE FROM END OF BUSHING TO END OF DRIVEN SHAFT	C DISTANCE FROM END OF BUSHING TO OPPOSITE END OF HOLLOW SHAFT	KEYWAY WIDTH	MINIMUM KEYWAY LENGTH FROM END OF DRIVEN SHAFT
23	1.000	1.25	4.37	7.87	.25	3.12
	1.1875	1.25	4.37	7.87	.25	3.12
26	1.000	1.38	4.50	8.00	.25	3.12
	1.1875	1.38	4.50	8.00	.25	3.12
	1.250	1.38	4.50	8.00	.25	3.12
	1.375	1.38	4.50	8.00	.3125	3.12
30	1.375	1.44	5.12	9.20	.3125	3.68
	1.4375	1.44	5.12	9.20	.375	3.68
	1.500	1.44	5.12	9.20	.375	3.68
35	1.375	1.44	5.12	10.18	.3125	3.68
	1.4375	1.44	5.12	10.18	.375	3.68
	1.500	1.44	5.12	10.18	.375	3.68
40	1.500	1.69	6.24	11.51	.375	4.55
	1.6875	1.69	6.24	11.51	.375	4.55
47	1.9375	2.13	7.44	14.01	.500	5.31
	2.1875	2.13	7.44	14.01	.500	5.31

MODIFICATIONS/ACCESSORIES



TIGEAR-2 TAPERED BUSHING DIMENSIONS

SINGLE BUSHING WITH KEY

Bushing Located on Opposite Side of Reducer

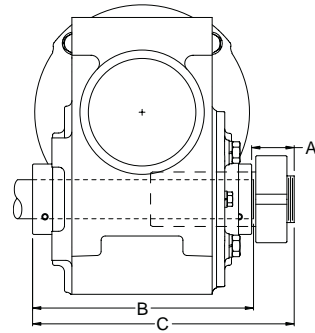

REDUCER SIZE	DRIVEN SHAFT DIAMETER	A DISTANCE FROM END OF HOLLOW SHAFT TO END OF BUSHING	B DISTANCE FROM END OF HOLLOW SHAFT TO END OF DRIVEN SHAFT	C DISTANCE FROM HOLLOW SHAFT TO END OF BUSHING	KEYWAY WIDTH	MINIMUM KEYWAY LENGTH FROM END OF DRIVEN SHAFT
23	1.000	1.25	6.75	7.87	.25	1.75
	1.1875	1.25	6.75	7.87	.25	2.00
26	1.000	1.38	6.75	8.00	.25	1.75
	1.1875	1.38	6.75	8.00	.25	2.00
	1.250	1.38	6.75	8.00	.25	2.13
30	1.375	1.38	6.75	8.00	.3125	2.44
	1.375	1.44	7.89	9.20	.3125	2.44
	1.4375	1.44	7.89	9.20	.375	2.50
35	1.500	1.44	7.89	9.20	.375	2.63
	1.375	1.44	8.87	10.18	.3125	2.44
	1.4375	1.44	8.87	10.18	.375	2.50
40	1.500	1.44	8.87	10.18	.375	2.63
	1.500	1.69	9.95	11.51	.375	2.63
	1.6875	1.69	9.95	11.51	.375	2.88
47	1.9375	2.13	12.01	14.01	.500	3.38
	2.1875	2.13	12.01	14.01	.500	3.75

FEATURES/BENEFITS PAGE G4-2	SPECIFICATION PAGE G4-8	NOMENCLATURE PAGE G4-9	SELECTION/DIMENSIONS PAGE G4-16
--------------------------------	----------------------------	---------------------------	------------------------------------

MODIFICATIONS/ACCESSORIES



TIGEAR-2 TAPERED BUSHING DIMENSIONS DOUBLE BUSHING WITH KEY

This is the preferred mounting method for double bushing applications.

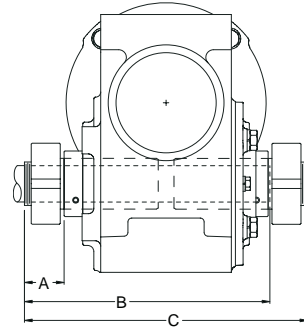

REDUCER SIZE	DRIVEN SHAFT DIAMETER	A DISTANCE FROM END OF BUSHING TO END OF HOLLOW SHAFT	B DISTANCE FROM END OF BUSHING TO END OF DRIVEN SHAFT	C TOTAL WIDTH OF BUSHINGS	KEYWAY WIDTH	MINIMUM KEYWAY LENGTH FROM END OF DRIVEN SHAFT
23	1.000	1.25	8.00	9.13	.25	6.75
	1.1875	1.25	8.00	9.13	.25	6.75
26	1.000	1.38	8.13	9.39	.25	6.75
	1.1875	1.38	8.13	9.39	.25	6.75
	1.250	1.38	8.13	9.39	.25	6.75
	1.375	1.38	8.13	9.39	.3125	6.75
30	1.375	1.44	9.33	10.65	.3125	7.89
	1.4375	1.44	9.33	10.65	.375	7.89
	1.500	1.44	9.33	10.65	.375	7.89
35	1.375	1.44	10.31	11.63	.3125	8.87
	1.4375	1.44	10.31	11.63	.375	8.87
	1.500	1.44	10.31	11.63	.375	8.87
40	1.500	1.69	11.64	13.21	.375	9.95
	1.6875	1.69	11.64	13.21	.375	9.95
47	1.9375	2.13	14.14	16.15	.500	12.01
	2.1875	2.13	14.14	16.15	.500	12.01

MODIFICATIONS/ACCESSORIES



TIGEAR-2 TAPERED BUSHING DIMENSIONS DOUBLE BUSHING WITHOUT KEY

Do not use for brake motor applications or other critical applications

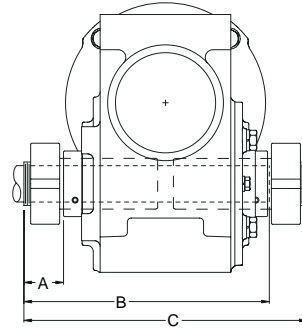

REDUCER SIZE	A DISTANCE FROM END OF BUSHING TO END OF HOLLOW SHAFT	B DISTANCE FROM END OF BUSHING TO END OF DRIVEN SHAFT	C TOTAL WIDTH OF BUSHINGS
23	1.25	8.00	9.13
26	1.38	8.13	9.39
30	1.44	9.33	10.65
35	1.44	10.31	11.63
40	1.69	11.64	13.21
47	2.13	14.14	16.15

FEATURES/BENEFITS PAGE G4-2	SPECIFICATION PAGE G4-8	NOMENCLATURE PAGE G4-9	SELECTION/DIMENSIONS PAGE G4-16
--------------------------------	----------------------------	---------------------------	------------------------------------

MODIFICATIONS/ACCESSORIES



TIGEAR-2 OUTPUT BRACKET KIT

The Output Bracket Kit is used to mount the reducer to a flat surface perpendicular to the output shaft. On Hollow Shaft units, an output bracket may be substituted for a tie rod kit to restrain reactions. Each kit consists of a bracket and required mounting hardware. The Output Bracket kit can be mounted to either side of the reducer.

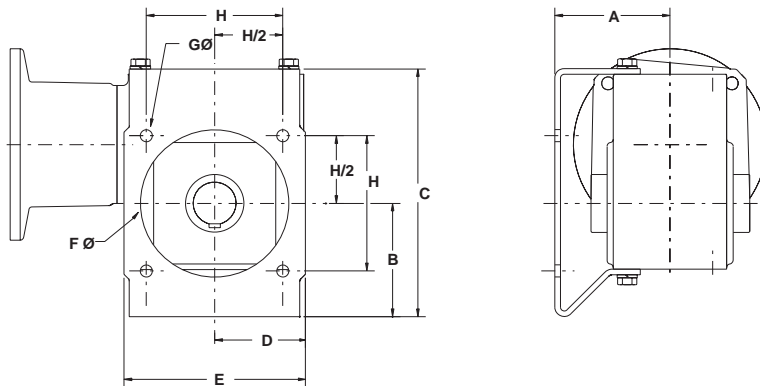

CASE SIZE	KIT NO.	A	B	C	D	E	F	G	H
13	13BRACKET	3.00	3.08	6.69	2.33	4.66	3.81	0.34	3.54
15	15BRACKET	3.21	2.81	6.86	2.33	4.66	3.81	0.34	3.54
17	17BRACKET	3.50	3.40	7.71	2.77	5.54	4.44	0.34	4.16
20	20BRACKET	3.88	3.85	8.42	3.05	6.10	5.00	0.41	4.60
23	23BRACKET	3.72	3.92	9.05	3.25	6.50	5.00	0.41	5.30
26	26BRACKET	4.63	4.20	10.20	3.80	7.60	6.56	0.41	5.66
30	30BRACKET	4.50	4.12	10.27	4.39	8.14	7.00	0.41	6.36
35	35BRACKET	5.25	5.51	12.35	4.80	9.60	8.56	0.41	7.07
40	40BRACKET	NA	NA	NA	NA	NA	NA	NA	NA
47	47BRACKET	NA	NA	NA	NA	NA	NA	NA	NA

FEATURES/BENEFITS
PAGE G4-2

SPECIFICATION
PAGE G4-8

NOMENCLATURE
PAGE G4-9

SELECTION/DIMENSIONS
PAGE G4-16

MODIFICATIONS/ACCESSORIES



TIGEAR-2 PLUG-IN OUTPUT SHAFT KIT

A Plug-In Output Shaft Kit permits the conversion of a Hollow output to a Solid output reducer. Customers can easily change output shaft locations from L to R with this accessory. These kits can only be used with **standard** max bore reducers. They cannot be used with **alternative** max bore reducers. If other shaft requirements are necessary, consult DODGE. Kit includes shaft, snap rings and keys.

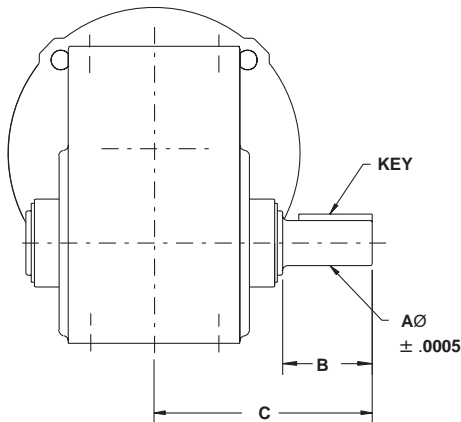

Case Size	Kit. No.	A +/- .0005
13	13PLUGIN	0.6245
15	15PLUGIN	0.7495
17	17PLUGIN	0.8745
20	20PLUGIN	0.9995
23	23PLUGIN	1.1245
26	26PLUGIN	1.1245
30	30PLUGIN	1.3745
35	35PLUGIN	1.4995
40	40PLUGIN	1.8745
47	47PLUGIN	1.9995

Case Size	B	C	KEY
13	1.82	4.47	3/16 SQ x 1.50
15	1.82	4.47	3/16 SQ x 1.50
17	1.81	4.81	3/16 SQ x 1.50
20	2.11	5.31	1/4 SQ x 1.75
23	2.36	6.05	1/4 SQ x 1.98
26	2.36	6.05	1/4 SQ x 1.98
30	3.43	7.76	5/16 SQ x 3.00
35	3.34	8.17	3/8 SQ x 2.93
40	4.10	9.46	1/2 SQ x 3.53
47	3.93	10.46	1/2 SQ x 3.53

Overhung Load Capacity Lbs At 1750 rpm Input

Case Size	Ratio	OHL Capacity
13	All	610 lbs.
15	All	650 lbs.
17	All	1200 lbs.
20	All	1600 lbs.
23	All	2000 lbs.
26	All	2000 lbs.
30	All	2550 lbs.
35	All	3100 lbs.
40	5:1 to 10:1	2800 lbs.
40	15:1 and higher	4080 lbs.
47	All	4600 lbs.

Note: OHL capacity is calculated at a distance of one hollow output hub bore diameter from the end of the output hub.

FEATURES/BENEFITS PAGE G4-2	SPECIFICATION PAGE G4-8	NOMENCLATURE PAGE G4-9	SELECTION/DIMENSIONS PAGE G4-16
--------------------------------	----------------------------	---------------------------	------------------------------------

MODIFICATIONS/ACCESSORIES

TIGEAR-2 TRANSITION BASE KITS FOR DOWNSIZING

TIGEAR-2 transition base kits allow a smaller reducer to “drop-in” to the bolt hole pattern of the next size larger reducer. This scenario is possible in many replacement situations because of the increases in the TIGEAR-2 output torque capacity.

The base will locate the output shaft in the same position as the one from the larger reducer being replaced.

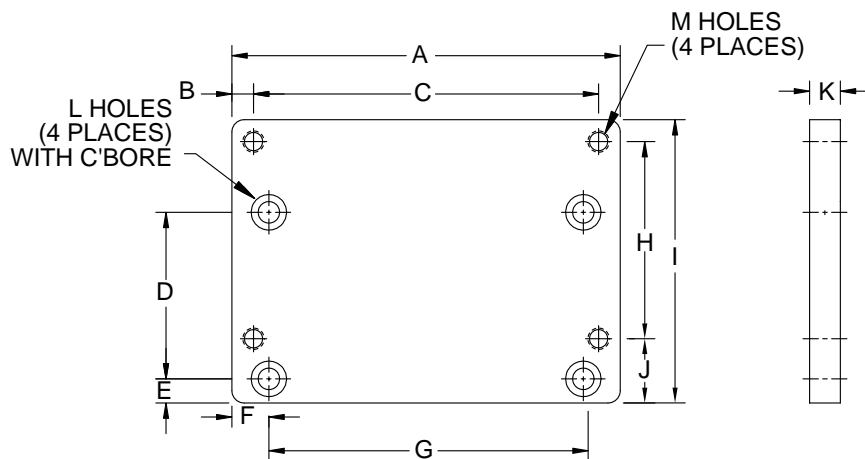

DOWN-SIZING		KIT NUMBER	A	B	C	D	E	F	G	H	I	J	K	L HOLES	M HOLES
FROM	TO														
26	23	23DOWN26	7.13	0.38	6.38	2.88	0.69	1.07	5.00	3.38	4.69	0.93	0.63	7/16 DRILL THRU	3/8-16 TAP THRU
30	26	26DOWN30	7.88	0.44	7.00	3.38	0.49	0.75	6.38	4.00	5.75	1.31	0.63	7/16 DRILL THRU	7/16-14 TAP THRU
35	30	30DOWN35	8.38	0.44	7.50	4.00	0.62	0.69	7.00	4.00	5.82	1.38	1.00	1/2 DRILL THRU	7/16-14 TAP THRU

TIGEAR-2 XL RIGHT ANGLE CONVERSION BASE

TIGEAR-2 conversion base kits allow customers who currently use single reduction Master XL right angle reducers to convert to TIGEAR-2.

The conversion base kits will be supplied with hardware to attach the conversion base to TIGEAR-2 unit.

Please note some dimensional differences exist between the Master XL reducers and TIGEAR-2 reducers with conversion base.

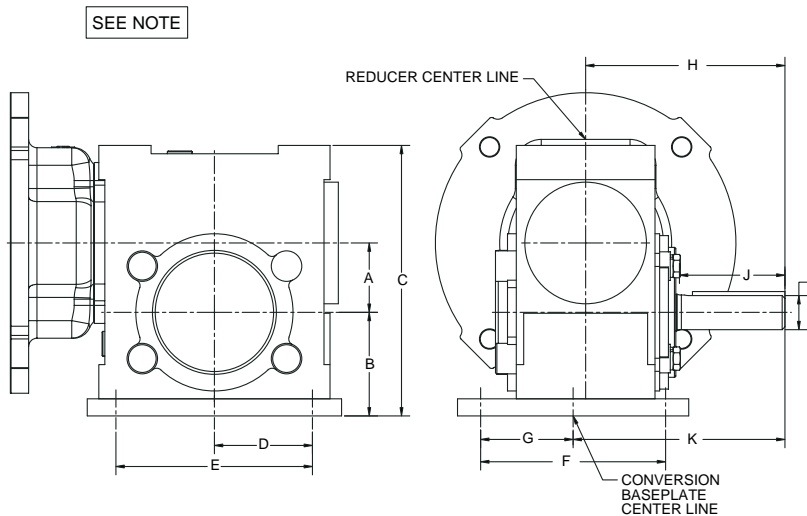

TIGEAR-2 SIZES	CONVERTED XL SIZE	KIT NO.	A	B	C	D	E	F	G	H	I	J	K	MASTER XL BASE TO CENTERLINE OF OUTPUT SHAFT
15	12	W12TO15BASE	1.50	2.250	5.86	2.12	4.25	4.00	2.00	4.31	0.750	2.23	4.00	2.23
17	16	W16TO17BASE	1.75	2.480	6.34	3.00	6.00	4.50	2.25	4.31	0.875	1.74	4.56	2.48
23	21	W21TO23BASE	2.31	3.365	8.25	3.50	7.00	7.00	3.50	5.14	1.125	2.18	6.00	3.37
35	28	W28TO35BASE	3.50	4.855	11.44	3.99	8.00	8.00	4.00	7.06	1.500	3.51	7.81	*3.985

* Denotes dimensional difference between XL Right angle and TIGEAR-2 unit with conversion base.

FEATURES/BENEFITS PAGE G4-2	SPECIFICATION PAGE G4-8	NOMENCLATURE PAGE G4-9	SELECTION/DIMENSIONS PAGE G4-16
--------------------------------	----------------------------	---------------------------	------------------------------------

TIGEAR-2 LUBRICATION

The DODGE TIGEAR-2 reducer is factory filled with a new synthetic lubricant which eliminates costly preparation time normally required to put a reducer into service. The lubricant supplied is a high performance, H1 food grade lubricant, suitable for all mounting positions. When reducer selections are properly service factored to account for the thermal limitations of the reducer, the standard lubricant covers an operating ambient temperature range of -10°F to 165°F. No other lubricant available on the market provides the outstanding wear protection and thermal abilities of the factory-filled lubricant. Other lubricants, including Mobil SHC series lubricant, must not be mixed with the factory supplied lubricant.

Low Temperature Lubricant

For operating ambient temperature ranges from -10°F to -30°F, order Low Temperature Lubricant at the time of reducer order. The low temperature lubricant has all of the high performance features of the standard temperature lubricant, but has been modified for lower temperatures. Contact Application Engineering for temperatures below -30°F.

Approximate Oil Volumes

REDUCER CONFIGURATION	REDUCER SIZE									
	13	15	17	20	23	26	30	35	40	47
(QH) Quill Input Hollow Output Shaft	6 oz.	7 oz.	11 oz.	14 oz.	21 oz.	28 oz.	44 oz.	60 oz.	89 oz.	164 oz.
(QS) Quill Input Solid Output Shaft	6 oz.	7 oz.	12 oz.	15 oz.	23 oz.	32 oz.	48 oz.	66 oz.	97 oz.	176 oz.
Separate or 3-Piece Coupled Input (AH & SH) Hollow Output Shaft	9 oz.	10 oz.	15 oz.	21 oz.	28 oz.	38 oz.	59 oz.	82 oz.	140 oz.	228 oz.
Separate or 3-Piece Coupled Input (AS & SS) Solid Output Shaft	9 oz.	11 oz.	18 oz.	23 oz.	32 oz.	44 oz.	70 oz.	94 oz.	144 oz.	266 oz.

Replacement factory recommended TIGEAR Lubricant may be ordered from DODGE. Use the following table to determine part number.

Standard Temperature Range		
Volume	Quart 32 oz.	Gallon 128 oz.
Part Number	334863	334862

Low Temperature Range		
Volume	Quart 32 oz.	Gallon 128 oz.
Part Number	334861	334860

FEATURES/BENEFITS PAGE G4-2	SPECIFICATION PAGE G4-8	NOMENCLATURE PAGE G4-9	SELECTION/DIMENSIONS PAGE G4-16
--------------------------------	----------------------------	---------------------------	------------------------------------

TIGEAR-2

OUTPUT SHAFT REVERSAL KITS

Tigear-2 reducers are stocked in left-hand and right-hand output shaft configurations. However, it is possible to convert a left-hand unit to a right-hand unit, or a right-hand unit to a left-hand unit in the field. A shaft reversal kit is required to make this change. Each kit includes a shaft seal, bore plug, o-ring, and instructions.

Reducer Size	Kit Part Number
13	13SHAFTREV
15	15SHAFTREV
17	17SHAFTREV
20	20SHAFTREV
23	23SHAFTREV
26	26SHAFTREV
30	30SHAFTREV
35	35SHAFTREV
40	40SHAFTREV
47	47SHAFTREV

MODIFICATIONS/ACCESSORIES



TIGEAR-2 HOLLOW OUTPUT SAFETY COVERS

Safety Cover Kits are available to enclose the rotating shaft on hollow output reducers. The kits are designed to fit reducers equipped with GRIP TIGHT or straight-bore bushings, or reducers equipped with the standard straight-bore hollow output shaft. The covers are made from a water-resistant polymer and include stainless steel fasteners for mild washdown applications. The covers are not water tight and it is possible for solid material to collect near the covers.

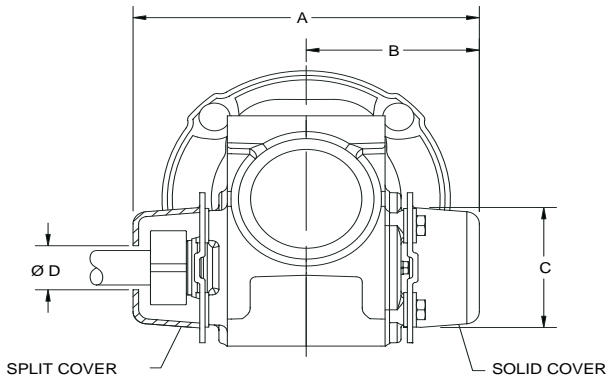

SAFETY COVER - END VIEW

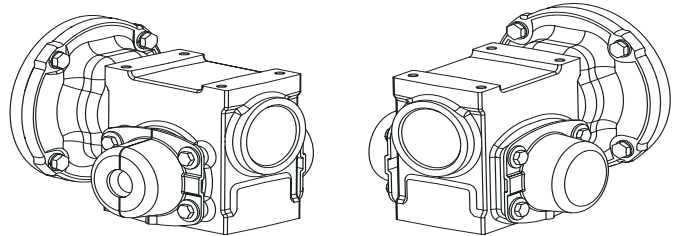

SAFETY COVER - ISOMETRIC VIEWS

Case Size	Cover Style	Kit Number	A	B	C	D
17	Closed	17CLSDCOVER	8.0	4.0	3.1	---
	Open	17OPENCOVER	8.0	4.0	3.1	1.12
20	Closed	20CLSDCOVER	8.2	4.1	3.8	---
	Open	20OPENCOVER	8.2	4.1	3.8	1.50
23	Closed	23CLSDCOVER	9.2	4.6	3.4	---
	Open	23OPENCOVER	9.2	4.6	3.4	1.75
26	Closed	26CLSDCOVER	9.6	4.8	4.4	---
	Open	26OPENCOVER	9.6	4.8	4.4	1.94
30	Closed	30CLSDCOVER	10.8	5.4	3.9	---
	Open	30OPENCOVER	10.8	5.4	3.9	2.19
35	Closed	35CLSDCOVER	12.0	6.0	5.5	---
	Open	35OPENCOVER	12.0	6.0	5.5	2.19
40	Closed	40CLSDCOVER	13.6	6.8	4.5	---
	Open	40OPENCOVER	13.6	6.8	4.5	2.44



TIGEAR-2

Shipping Weights

Input Style	Motor Frame	Reducer Case Size									
		13	15	17	20	23	26	30	35	40	47
Quill	56/140	36	39	43	48	55	65	89	109	135	210
and	180/210					55	65	89	109	135	210
Separate	250									135	210

Input Style	Motor Frame	Reducer Case Size									
		13	15	17	20	23	26	30	35	40	47
Coupled	56/140	39	42	46	52	59	69	95	115	144	219
	180/210					59	69	95	115	144	219
	250									144	219

Nameplate Layout

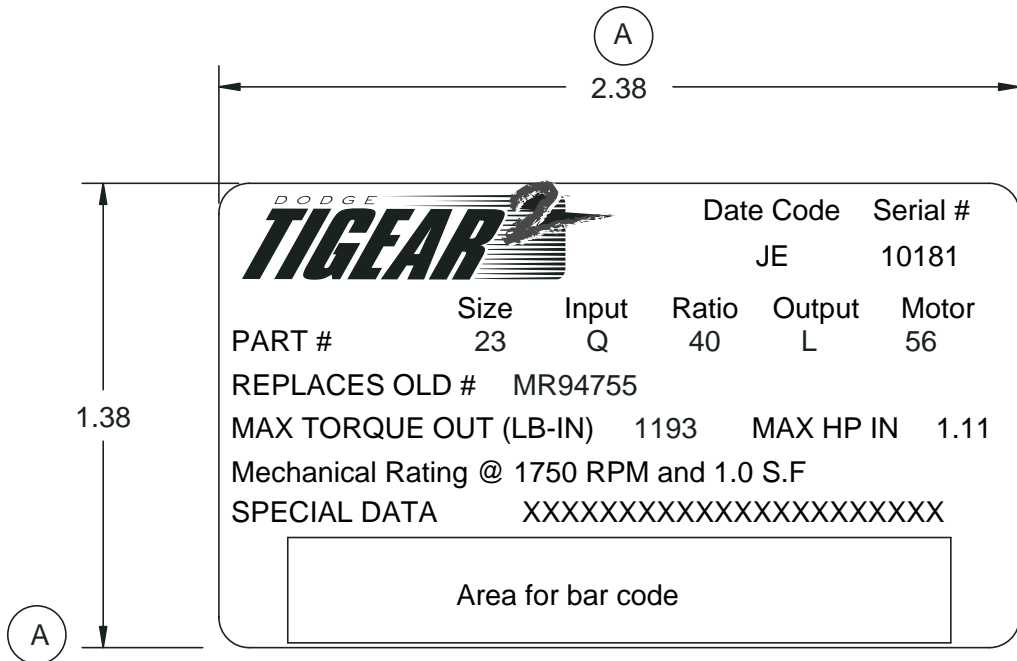

ENGINEERING/TECHNICAL**DODGE®****Manufactured Date Code Chart**

	JAN	FEB	MAR	APR	MAY	JUN	JUL	AUG	SEP	OCT	NOV	DEC
1961	AL	BL	CL	DL	EL	FL	GL	HL	JL	KL	LL	ML
1962	AM	BM	CM	DM	EM	FM	GM	HM	JM	KM	LM	MM
1963	AN	BN	CN	DN	EN	FN	GN	HN	JN	KN	LN	MN
1964	AP	BP	CP	DP	EP	FP	GP	HP	JP	KP	LP	MP
1965	AQ	BQ	CQ	DQ	EQ	FQ	GQ	HQ	JQ	KQ	LQ	MQ
1966	AR	BR	CR	DR	ER	FR	GR	HR	JR	KR	LR	MR
1967	AS	BS	CS	DS	ES	FS	GS	HS	JS	KS	LS	MS
1968	AT	BT	CT	DT	ET	FT	GT	HT	JT	KT	LT	MT
1969	AU	BU	CU	DU	EU	FU	GU	HU	JU	KU	LU	MU
1970	AV	BV	CV	DV	EV	FV	GV	HV	JV	KV	LV	MV
1971	AW	BW	CW	DW	EW	FW	GW	HW	JW	KW	LW	MW
1972	AX	BX	CX	DX	EX	FX	GX	HX	JX	KX	LX	MX
1973	AY	BY	CY	DY	EY	FY	GY	HY	JY	KY	LY	MY
1974	AZ	BZ	CZ	DZ	EZ	FZ	GZ	HZ	JZ	KZ	LZ	MZ
1975	NA	PA	QA	RA	SA	TA	UA	VA	WA	XA	YA	ZA
1976	NB	PB	QB	RB	SB	TB	UB	VB	WB	XB	YB	ZB
1977	NC	PC	QC	RC	SC	TC	UC	VC	WC	XC	YC	ZC
1978	ND	PD	QD	RD	SD	TD	UD	VD	WD	XD	YD	ZD
1979	NE	PE	QE	RE	SE	TE	UE	VE	WE	XE	YE	ZE
1980	NF	PF	QF	RF	SF	TF	UF	VF	WF	XF	YF	ZF
1981	NG	PG	QG	RG	SG	TG	UG	VG	WG	XG	YG	ZG
1982	NH	PH	QH	RH	SH	TH	UH	VH	WH	XH	YH	ZH
1983	NJ	PJ	QJ	RJ	SJ	TJ	UJ	VJ	WJ	XJ	YJ	ZJ
1984	NK	PK	QK	RK	SK	TK	UK	VK	WK	XK	YK	ZK
1985	NL	PL	QL	RL	SL	TL	UL	VL	WL	XL	YL	ZL
1986	NM	PM	QM	RM	SM	TM	UM	VM	WM	XM	YM	ZM
1987	NN	PN	QN	RN	SN	TN	UN	VN	WN	XN	YN	ZN
1988	NP	PP	QP	RP	SP	TP	UP	VP	WP	XP	YP	ZP
1989	NQ	PQ	QQ	RQ	SQ	TQ	UQ	VQ	WQ	XQ	YQ	ZQ
1990	NR	PR	QR	RR	SR	TR	UR	VR	WR	XR	YR	ZR
1991	NS	PS	QS	RS	SS	TS	US	VS	WS	XS	YS	ZS
1992	NT	PT	QT	RT	ST	TT	UT	VT	WT	XT	YT	ZT
1993	NU	PU	QU	RU	SU	TU	UU	VU	WU	XU	YU	ZU
1994	NW	PW	QW	RW	SW	TW	UW	VW	WW	XW	YW	ZW
1995	NX	PX	QX	RX	SX	TX	UX	VX	WX	XX	YX	ZX
1996	NY	PY	QY	RY	SY	TY	UY	VY	WY	XY	YY	ZY
1997	NZ	PZ	QZ	RZ	SZ	TZ	UZ	VZ	WZ	XZ	YZ	ZZ
1998	AA	BA	CA	DA	EA	FA	GA	HA	JA	KA	LA	MA
1999	AB	BB	CB	DB	EB	FB	GB	HB	JB	KB	LB	MB
2000	AC	BC	CC	DC	EC	FC	GC	HC	JC	KC	LC	MC
2001	AD	BD	CD	DD	ED	FD	GD	HD	JD	KD	LD	MD
2002	AE	BE	CE	DE	EE	FE	GE	HE	JE	KE	LE	ME
2003	AF	BF	CF	DF	EF	FF	GF	HF	JF	KF	LF	MF
2004	AG	BG	CG	DG	EG	FG	GG	HG	JG	KG	LG	MG
2005	AH	BH	CH	DH	EH	FH	GH	HH	JH	KH	LH	MH
2006	AJ	BJ	CJ	DJ	EJ	FJ	GJ	HJ	JJ	KJ	LJ	MJ
2007	AK	BK	CK	DK	EK	FK	GK	HK	JK	KK	LK	MK
2008	AL	BL	CL	DL	EL	FL	GL	HL	JL	KL	LL	ML
2009	AM	BM	CM	DM	EM	FM	GM	HM	JM	KM	LM	MM
2010	AN	BN	CN	DN	EN	FN	GN	HN	JN	KN	LN	MN

NOTES



Gearing Reference Guide

TORQUE-ARM II

TORQUE-ARM

MAXIMUM Concentric Reducer

TIGEAR-2



RENEWAL PARTS

TIGEAR-2 Quill Input / Solid Output Sizes 13- 23

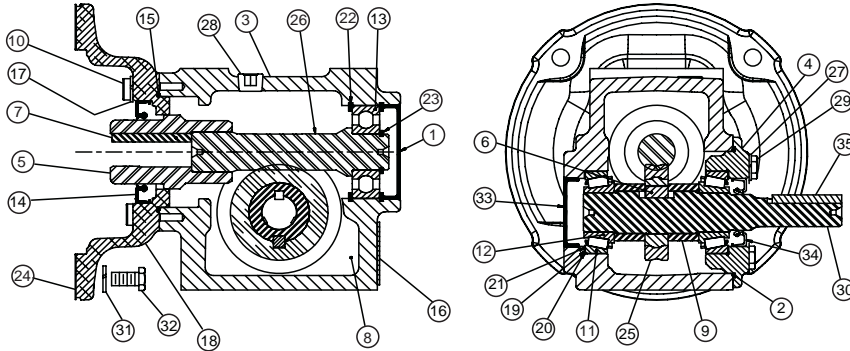

Ref No.	Description	Qty	13	15	17	20	23
			Part Number	Part Number	Part Number	Part Number	Part Number
1	INPUT BORE PLUG	1	276005	276005	276001	276001	276002
2	O-RING	1	276019	276019	276134	276355	334307
3	TIG2 SOLID GEARCASE	1	333210	333211	333212	333213	333214
4	T2 133& 150 SOLID BRG HSG	1	333265	333265	333266	333267	333268
5	QUILL CPLG 150 56C	1	See Gear Chart	See Gear Chart	See Gear Chart	See Gear Chart	See Gear Chart
6	GEAR KEY	1	333650	333661	333666	333671	333686
7	DRIV-LOK KEY 56-140	1	333698	333698	333667	333667	333698
	DRIV-LOK KEY 180TC	1	----	----	----	----	333707
	DRIV-LOK KEY 210TC	1	----	----	----	----	----
	DRIV-LOK KEY 250TC	1	----	----	----	----	----
8	TIGEAR 2 LUBRICANT	1	334863	334863	334863	334863	334863
9	SOLID SPACER	2	333725	333726	333727	333728	333729
10	SOCKET HEAD CAP SCR GR8	4	333801	333801	333801	333801	51492
	SCKT HD CAP SCR 180-210-250	4	----	----	----	----	----
11-12	BEARING CUP/CONE ASSM	2	335337	335337	411626-01-C	411626-01-A	411626-01-A
13	BALL BEARING	1	334218	334218	334219	334219	334220
14	INPUT SEAL T2 56-140	1	334274	334274	334274	334274	334276
	INPUT SEAL T2 180-210-250	1	----	----	----	----	----
15	"O-RING, NITRILE"	1	334301	334301	334301	334301	276355
16	TIGEAR 2 NAMEPLATE	1	334305	334305	334305	334305	334305
17	MED LOCKWASHER	4	419010	419010	419010	419010	275803

RENEWAL PARTS



TIGEAR-2 Quill Input / Solid Output Sizes 13 - 23

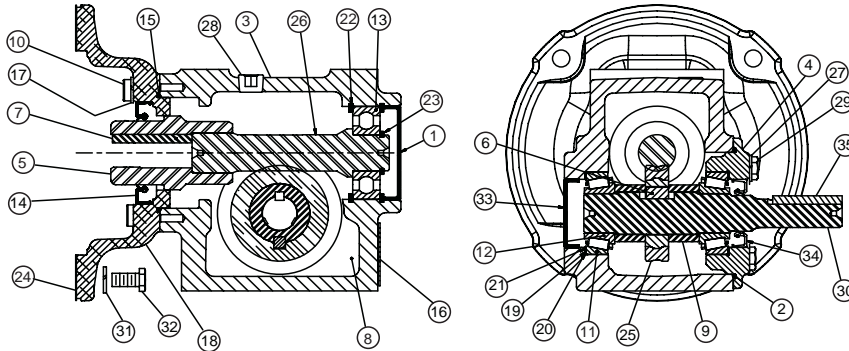

Ref No.	Description	Qty	13	15	17	20	23
			Part Number	Part Number	Part Number	Part Number	Part Number
18	MOTOR ADAPTER T2 56-140	1	333228	333228	333228	333228	333229
	MOTOR ADAPTER 180	1	----	----	----	----	334681
19-21	SHIM KIT	1	411642-42-E	411642-42-E	411623-33-A	411623-33-B	411623-33-B
22	INTERNAL RET RING	2	411637-02-AV	411637-02-AV	58256	58256	411637-01-A
23	EXTERNAL RET RING	1	411637-02-E		411637-02-AY	411637-02-AY	411637-02-N
24	56/140 M/A. GASKET	1	602028-43-F	602028-43-F	602028-43-F	602028-43-F	602028-43-F
	MTR ADPT GSKT 180-210-250	1	----	----	----	----	276335
25	TIG2 SOLID GEAR	1	See Gear Chart	See Gear Chart	See Gear Chart	See Gear Chart	See Gear Chart
26	TIG2 WORMSHAFT	1	See Gear Chart	See Gear Chart	See Gear Chart	See Gear Chart	See Gear Chart
27	MED LOCKWASHER	4	419009	419009	419010	419010	275803
28	PIPE PLUG 1/4" SOC.	2	411647-34-B	411647-34-B	411647-34-B	411647-34-B	411647-34-B
29	HEX HEAD CAP SCREW GR5	4	51302	51302	411405	411405	51929
30	SOLID O/P SHFT-SINGLE EXTN	1	333604	333605	333606	333607	333608
31	LOCK WASHER 56-140	4	275803	275803	275803	275803	275803
	LOCK WASHER 180-210	4	----	----	----	----	----
32	HEX HD CAP SCR MTR 56-140	4	51492	51492	51929	51492	51929
	HEX HD CAP SCR MTR 180-210	4	----	----	----	----	411631-63-A
	HEX HD CAP SCR MTR 250	4	----	----	----	----	----
33	OUTPUT BORE PLUG	1	276008	276008	334245	334247	334247
34	TIG2 SEAL, OUTPUT	1	334271	334271	334272	334273	334273
35	KEY	1	333665	333660	333665	55025	333685

FEATURES/BENEFITS PAGE G4-2	SPECIFICATION PAGE G4-8	NOMENCLATURE PAGE G4-9	MODIFICATION/ACCESSORIES PAGE G4-90
--------------------------------	----------------------------	---------------------------	--



RENEWAL PARTS

TIGEAR-2 Quill Input / Solid Output Sizes 26 - 47

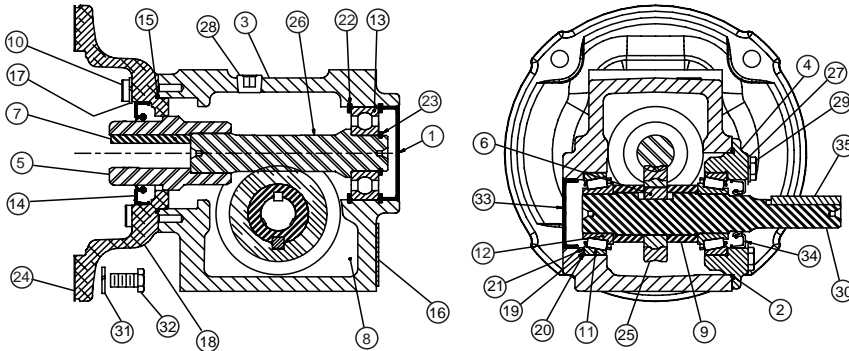

Ref No.	Description	Qty	26	30	35	40	47
			Part Number	Part Number	Part Number	Part Number	Part Number
1	INPUT BORE PLUG	1	334248	276004	276007	334250	334253
2	O-RING	1	334302	334308	276358	334313	334315
3	TIG2 SOLID GEARCASE	1	333215	333216	333217	334506	334576
4	T2 133& 150 SOLID BRG HSG	1	333269	333270	333271	334510	334580
5	QUILL CPLG 150 56C	1	See Gear Chart	See Gear Chart	See Gear Chart	See Gear Chart	See Gear Chart
6	GEAR KEY	1	333696	333706	333775	334564	334624
7	DRIV-LOK KEY 56-140	1	333698	333698	333715	334557	334557
	DRIV-LOK KEY 180TC	1	333707	333707	333707	334558	334558
	DRIV-LOK KEY 210TC	1	-----	-----	333721	334559	334559
	DRIV-LOK KEY 250TC	1	-----	-----	-----	334560	334560
8	TIGEAR 2 LUBRICANT	1	334862	334862	334862	334862	334862
9	SOLID SPACER	2	333730	333731	333732	334565	334625
10	SOCKET HEAD CAP SCR GR8	4	51492	51492	51952	51952	51952
	SCKT HD CAP SCR 180-210-250	4	-----	-----	334374	334374	334374
11-12	BEARING CUP/CONE ASSM	2	411626-01-A	335338	411626-01-R	335340	335344
13	BALL BEARING	1	334221	334222	334223	334224	334225
14	INPUT SEAL T2 56-140	1	334276	334276	334276	334276	334276
	INPUT SEAL T2 180-210-250	1	-----	-----	334279	334279	334279
15	O-RING, NITRILE	1	276355	276355	334302	334302	334302
16	TIGEAR 2 NAMEPLATE	1	334305	334305	334305	334305	334305
17	MED LOCKWASHER	4	275803	275803	275855	275855	275855

RENEWAL PARTS



TIGEAR-2 Quill Input / Solid Output Sizes 26 - 47

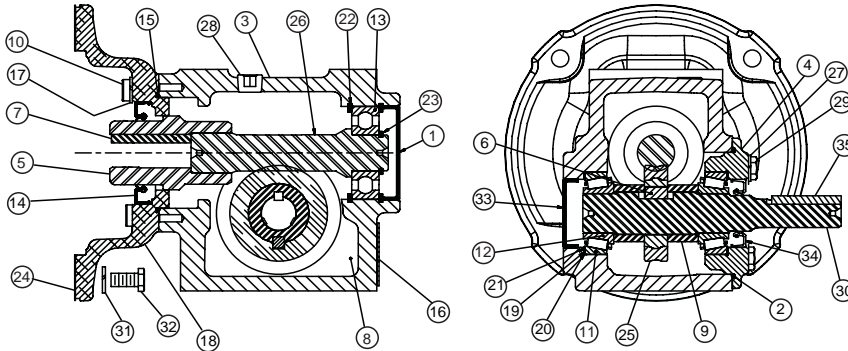

Ref No.	Description	Qty	26	30	35	40	47
			Part Number	Part Number	Part Number	Part Number	Part Number
18	MOTOR ADAPTER T2 56-140	1	333229	333229	334759	334759	334759
	MOTOR ADAPTER 180-210	1	334681	334681	333231	333231	333231
	MOTOR ADPT PLT 250TC (1)	1	----	----	----	334570	334570
19-21	SHIM KIT	1	411623-33-B	335330	411623-33-C	335331	335336
22	INTERNAL RET RING	2	278715	411637-02-AC	278717	51334	51335
23	EXTERNAL RET RING	1	411637-02-AP	411637-02-AR	411637-02-BA	334404	333933
24	56/140 M/A. GASKET	1	602028-43-F	602028-43-F	602028-43-F	602028-43-F	602028-43-F
	MTR ADPT GSKT 180-210-250 (4)	1	276335	276335	276335	276335	276335
25	TIG2 SOLID GEAR	1	See Gear Chart	See Gear Chart	See Gear Chart	See Gear Chart	See Gear Chart
26	TIG2 WORMSHAFT	1	See Gear Chart	See Gear Chart	See Gear Chart	See Gear Chart	See Gear Chart
27	MED LOCKWASHER	4	275803	275855	275855	419036	419036
28	PIPE PLUG 1/4" SOC.	2	411647-34-B	411647-34-B	411647-34-B	411647-34-B	411647-34-B
29	HEX HEAD CAP SCREW GR5	4	51929	51952	51952	411483	411484
30	SOLID O/P SHFT-SINGLE EXTN	1	333609	333610	333611	334554	334619
31	LOCK WASHER 56-140	4	275803	275803	275803	275803	275803
	LOCK WASHER 180-210	4	----	----	275855	275853	275853
32	HEX HD CAP SCR MTR 56-140	4	51929	51929	51929	51929	51929
	HEX HD CAP SCR MTR 180-210	4	411631-63-A	411631-63-A	411631-58-X	334896	334896
	HEX HD CAP SCR MTR 250	4	----	----	----	276446	276446
33	OUTPUT BORE PLUG	1	334247	334246	334254	334251	334252
34	TIG2 SEAL, OUTPUT	1	334273	334274	334275	334277	334278
35	KEY	1	333695	333705	333716	55127	55127

(1) 250TC adpt plate bolts onto 180-210 motor adapter.

(4) Frame size 250 uses qty 2.

FEATURES/BENEFITS PAGE G4-2	SPECIFICATION PAGE G4-8	NOMENCLATURE PAGE G4-9	MODIFICATION/ACCESSORIES PAGE G4-90
--------------------------------	----------------------------	---------------------------	--



RENEWAL PARTS

TIGEAR-2 Quill Input / Hollow Output Sizes 13 - 23

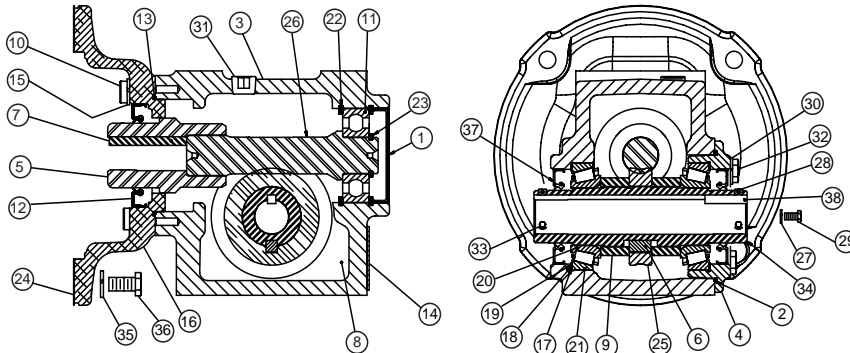

Ref No	Description	Qty	13	15	17	20	23
			Part Number	Part Number	Part Number	Part Number	Part Number
1	I/P RIBBED BORE PLUG	1	276005	276005	276001	276001	276002
2	O-RING	1	276019	276019	276134	276355	334307
3	TIG2 HOLLOW GEARCASE	1	333218	333219	333220	333221	333222
4	T2 HOLLOW BRG HOUSING	1	333281	333281	333282	333283	333284
5	QUILL CPLG	1	See Gear Chart	See Gear Chart	See Gear Chart	See Gear Chart	See Gear Chart
6	SOLID GEAR KEY	1	333650	333650	333666	333671	333686
7	DRIV-LOK KEY 56-140	1	333698	333698	333667	333667	333698
	DRIV-LOK KEY 180TC	1	----	----	----	----	333707
	DRIV-LOK KEY 210TC	1	----	----	----	----	----
	DRIV-LOK KEY 250TC	1	----	----	----	----	----
8	TIGEAR 2 LUBRICANT	1	334863	334863	334863	334863	334862
9	TIG2 HOLLW O/P SPACER	2	333733	333734	333735	333736	333737
10	SOCKET HEAD CAP SCREW	4	333801	333801	333801	333801	51492
11	BALL BRG.	1	334218	334218	334219	334219	334220
12	TIG2 SEAL, INPUT 56-140	1	334274	334274	334274	334274	334276
	TIG2 SEAL, INPUT 180-210	1	----	----	----	----	----
13	O-RING, NITRILE	1	334301	334301	334301	334301	276355
14	TIGEAR 2 NAMEPLATE FIN	1	334305	334305	334305	334305	334305
15	MED LOCKWASHER	4	419010	419010	419010	419010	275803
16	MOTOR ADAPTER T2 56-140	1	333228	333228	333228	333228	333229
	MOTOR ADAPTER, 180	1	----	----	----	----	334681
17-19	SHIM KIT	1	411623-33-B	411623-33-B	335330	411623-33-C	335331

TIGEAR-2 Quill Input / Hollow Output Sizes 13 - 23

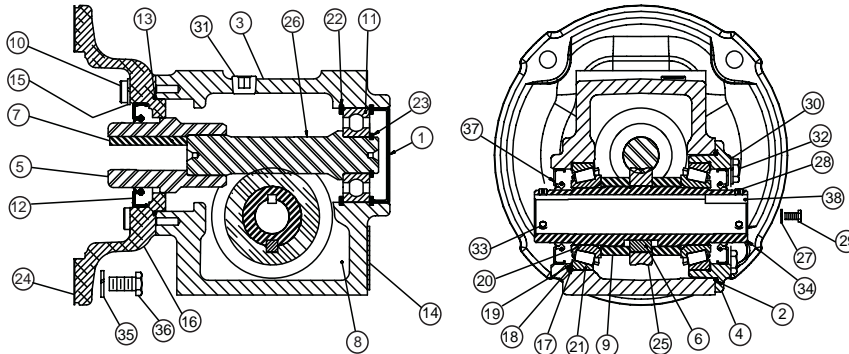

Ref No	Description	Qty	13	15	17	20	23
			Part Number	Part Number	Part Number	Part Number	Part Number
20-21	BEARING CUP/CONE ASSEMBLY	2	411626-01-A	411626-01-A	335338	335339	335340
22	INTERNAL RET RING	2	411637-02-AV	411637-02-AV	58256	58256	411637-01-A
23	EXTERNAL RET RING	1	411637-02-E	411637-02-E	411637-02-AY	411637-02-AY	411637-02-N
24	56/140 M/A. GASKET	1	602028-43-F	602028-43-F	602028-43-F	602028-43-F	602028-43-F
	MOTOR ADPT GASKET 180-210-250	1	----	----	----	----	276335
25	TIG2 HOLLOW GEAR	1	See Gear Chart	See Gear Chart	See Gear Chart	See Gear Chart	See Gear Chart
26	TIG2 WORMSHAFT	1	See Gear Chart	See Gear Chart	See Gear Chart	See Gear Chart	See Gear Chart
27	MED LOCKWASHER	2	419007	419007	419007	419007	419009
28	SET SCREW	2	400140	400140	400140	400140	400140
29	HEX HEAD CAP SCREW	2	58270	58270	333800	333800	51302
30	MED LOCKWASHER	4	419009	419009	419010	419010	275803
31	PIPE PLUG 1/4" OC.	2	411647-34-B	411647-34-B	411647-34-B	411647-34-B	411647-34-B
32	HEX HEAD CAP SCREW	4	51302	51302	411405	411405	51929
33	SET SCREW	4	275953	275953	275953	275953	275953
34	TIG2 HOLLOW O/P SHAFT	1	333629	333629	333631	334789	333633
35	LOCK WASHER 56-140	4	275803	275803	275803	275803	275803
	LOCK WASHER 180	4	----	----	----	----	----
36	HEX HEAD CAP SCREW	4	51492	51492	51929	51492	51929
	SHCS MTR MOUNTING 180-210	4	----	----	----	----	411631-63-A
	SHCS MTR MOUNTING 250	4	----	----	----	----	----
37	SEAL TIGEAR 2, OUTPUT	2	334273	334273	334274	334276	334277
38	OUTPUT KEY	1	54783	54783	55025	55025	333687

FEATURES/BENEFITS PAGE G4-2	SPECIFICATION PAGE G4-8	NOMENCLATURE PAGE G4-9	MODIFICATION/ACCESSORIES PAGE G4-90
--------------------------------	----------------------------	---------------------------	--



RENEWAL PARTS

TIGEAR-2 Quill Input / Hollow Output Sizes 26 - 47

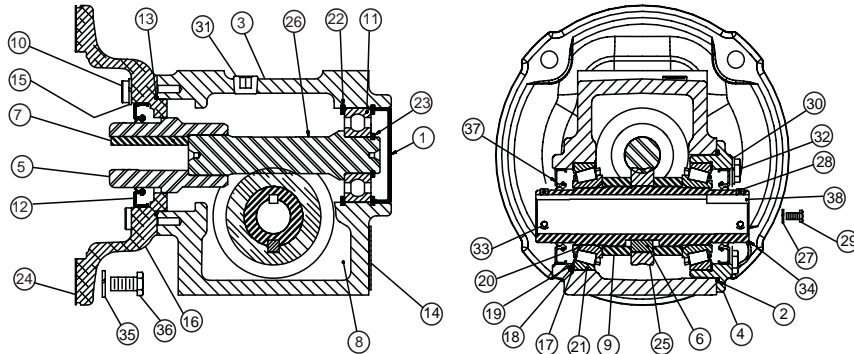

Ref No	Description	Qty	26	30	35	40	47
			Part Number	Part Number	Part Number	Part Number	Part Number
1	I/P RIBBED BORE PLUG	1	334248	276004	276007	334250	334253
2	O-RING	1	334302	334308	276358	334313	334315
3	TIG2 HOLLOW GEARCASE	1	333223	333224	333225	334507	334577
4	T2 HOLLOW BRG HOUSING	1	333285	333286	333287	334512	334582
5	QUILL CPLG	1	See Gear Chart	See Gear Chart	See Gear Chart	See Gear Chart	See Gear Chart
6	SOLID GEAR KEY	1	333670	333712	333717	334564	334624
7	DRIV-LOK KEY 56-140	1	333698	333698	333715	334557	-----
	DRIV-LOK KEY 180TC	1	333707	333707	333707	334558	334558
	DRIV-LOK KEY 210TC	1	-----	-----	333721	334559	334559
	DRIV-LOK KEY 250TC	1	-----	-----	-----	334560	334560
8	TIGEAR 2 LUBRICANT	1	334862	334862	334862	334862	334862
9	TIG2 HOLLW O/P SPACER	2	333738	333739	333740	334566	334626
10	SOCKET HEAD CAP SCREW	4	51492	51492	334374	334374	334374
11	BALL BRG.	1	334221	334222	334223	334224	334225
12	TIG2 SEAL, INPUT 56-140	1	334276	334276	334276	334276	334276
	TIG2 SEAL, INPUT 180-210	1	-----	-----	334279	334279	334279
13	O-RING, NITRILE	1	276355	276355	334302	334302	334302
14	TIGEAR 2 NAMEPLATE FIN	1	334305	334305	334305	334305	334305
15	MED LOCKWASHER	4	275803	275803	275855	275855	275855
16	MOTOR ADAPTER T2 56-140	1	333229	333229	334759	334759	-----
	MOTOR ADAPTER, 180-210TC	1	334681	334681	333231	333231	333231
	MOTOR ADPT PLATE 250TC (2)	1	-----	-----	-----	334570	334570
17-19	SHIM KIT	1	335332	335333	335333	335334	335335

(2) Adapter plate bolts onto 180-210 adapter 333231.

FEATURES/BENEFITS PAGE G4-2	SPECIFICATION PAGE G4-8	NOMENCLATURE PAGE G4-9	MODIFICATION/ACCESSORIES PAGE G4-90
--------------------------------	----------------------------	---------------------------	--

RENEWAL PARTS



TIGEAR-2 Quill Input / Hollow Output Sizes 26 - 47

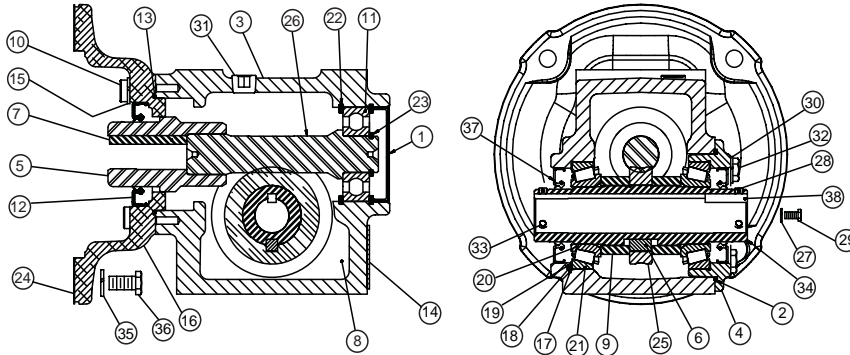

Ref No	Description	Qty	26	30	35	40	47
			Part Number	Part Number	Part Number	Part Number	Part Number
20-21	BEARIN CUP/CONE ASSEMBLY	2	411626-01-BJ	335341	335341	335342	335343
22	INTERNAL RET RING	2	278715	411637-02-AC	278717	51334	51335
23	EXTERNAL RET RING	1	411637-02-AP	411637-02-AR	411637-02-BA	334404	333933
24	56/140 M/A. GASKET	1	602028-43-F	602028-43-F	602028-43-F	602028-43-F	-----
	MOTOR ADPT GASKET 180-210-250 (3)	1	276335	276335	276335	276335	276335
25	TIG2 HOLLOW GEAR	1	See Gear Chart	See Gear Chart	See Gear Chart	See Gear Chart	See Gear Chart
26	TIG2 WORMSHAFT	1	See Gear Chart	See Gear Chart	See Gear Chart	See Gear Chart	See Gear Chart
27	MED LOCKWASHER	2	419009	419009	419009	419009	419009
28	SET SCREW	2	400140	400140	400140	400140	275953
29	HEX HEAD CAP SCREW	2	51302	411397	411396	411396	411402
30	MED LOCKWASHER	4	275803	275855	275855	419036	419036
31	PIPE PLUG 1/4" SOC.	2	411647-34-B	411647-34-B	411647-34-B	411647-34-B	411647-34-B
32	HEX HEAD CAP SCREW	4	51929	51952	51952	411483	411484
33	SET SCREW	4	275962	275954	275954	333805	333805
34	TIG2 HOLLOW O/P SHAFT	1	333634	333635	333636	334556	334621
35	LOCK WASHER 56-140	4	275803	275803	275803	275803	-----
	LOCK WASHER 180	4	-----	-----	-----	275853	275853
36	HEX HEAD CAP SCREW	4	51929	51929	51929	51929	-----
	SHCS MTR MOUNTING 180-210	4	411631-63-A	411631-63-A	411631-58-X	334896	334896
	SHCS MTR MOUNTING 250	4	-----	-----	-----	276446	276446
37	SEAL TIGEAR 2, OUTPUT"	2	334278	334279	334279	334280	334281
38	OUTPUT KEY	1	333687	333709	333709	334563	334623

FEATURES/BENEFITS PAGE G4-2	SPECIFICATION PAGE G4-8	NOMENCLATURE PAGE G4-9	MODIFICATION/ACCESSORIES PAGE G4-90
--------------------------------	----------------------------	---------------------------	--



RENEWAL PARTS

TIGEAR-2 Separate Input / Solid Output Sizes 13 - 23

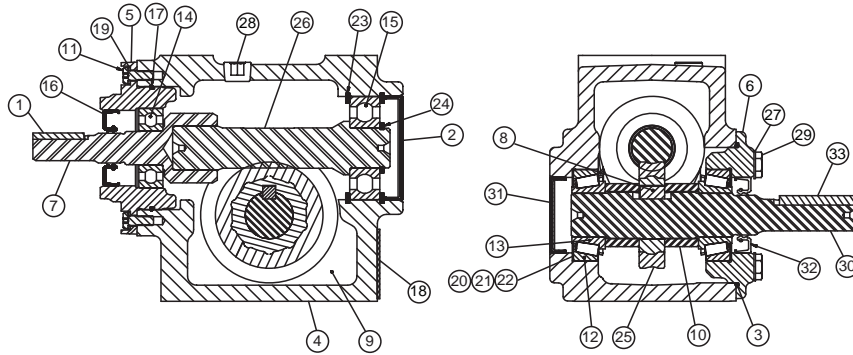

Ref No	Description	Qty	13	15	17	20	23
			Part Number	Part Number	Part Number	Part Number	Part Number
1	INPUT KEY	1	55582	55582	54783	54783	54783
2	I/P RIBBED B/P	1	276005	276005	276001	276001	276002
3	O-RING	1	276019	276019	276134	276355	334307
4	TIG2 SOLID GEARCASE	1	333210	333211	333212	333213	333214
5	T2 I/P BRG CARRIER	1	333245	333245	333246	333246	333249
6	T2 SOLID BRG HSG	1	333265	333265	333266	333267	333268
7	TIG2 INPUT COUPLING	1	See Gear Chart	See Gear Chart	See Gear Chart	See Gear Chart	See Gear Chart
8	SOLID GEAR KEY	1	333650	333661	333666	333671	333686
9	TIGEAR 2 LUBRICANT	1	334863	334863	334863	334863	334862
10	SOLID SPACER	2	333725	333726	333727	333728	333729
11	LHCS PLAIN	2	333808	333808	333808	333808	333807
12-13	BEARING CUP/CONE ASSM	2	335337	335337	411626-01-C	411626-01-A	411626-01-A
14	BALL BEARING	1	334211	334211	334212	334212	334213
15	BALL BEARING	1	334218	334218	334219	334219	334220
16	TIG2 INPUT SEAL	1	334270	334270	334271	334271	334272
17	O-RING, NITRILE	1	334300	334300	334300	334300	334303
18	TIGEAR 2 NAMEPLATE	1	334305	334305	334305	334305	334305
19	MED LOCKWASHER	2	419007	419007	419007	419007	419009
20-22	SHIM KIT	1	411642-46-E	411642-46-E	411623-33-A	411623-33-B	411623-33-B
23	INTERNAL RET RING	2	411637-02-AV	411637-02-AV	j58256	58256	411637-01-A
24	EXTERNAL RET RING	1	411637-02-E	411637-02-E	411637-02-AV	411637-02-AV	411637-02-N
25	SOLID GEAR	1	See Gear Chart	See Gear Chart	See Gear Chart	See Gear Chart	See Gear Chart
26	WORMSHAFT	1	See Gear Chart	See Gear Chart	See Gear Chart	See Gear Chart	See Gear Chart
27	PIPE PLUG 1/4" SOC. (1)	2	411647-34-B	411647-34-B	411647-34-B	411647-34-B	411647-34-B
28	MED LOCKWASHER	4	419009	419009	419010	419010	275803
29	HEX HEAD CAP SCREW	4	51302	51302	411405	411405	51J929
30	O/P SHAFT, SINGLE EXTN	1	333604	333605	333606	333607	333608
31	O/P RIBBED BORE PLUG	1	276008	276008	334245	334247	334247
32	TIG2 SEAL, OUTPUT	1	334271	334271	334272	334273	334273
33	KEY, OUTPUT	1	333665	333660	333665	55025	333685

(1) Size 400 & 475 uses qty 1

(2) Size 475 requires 266 oz. of lube. Order qty 2 (gal) 334862 & qty 1 (qt.) of 334863.

FEATURES/BENEFITS
PAGE G4-2

SPECIFICATION
PAGE G4-8

NOMENCLATURE
PAGE G4-9

MODIFICATION/ACCESSORIES
PAGE G4-90

RENEWAL PARTS



TIGEAR-2 Separate Input / Solid Output Sizes 26 - 47

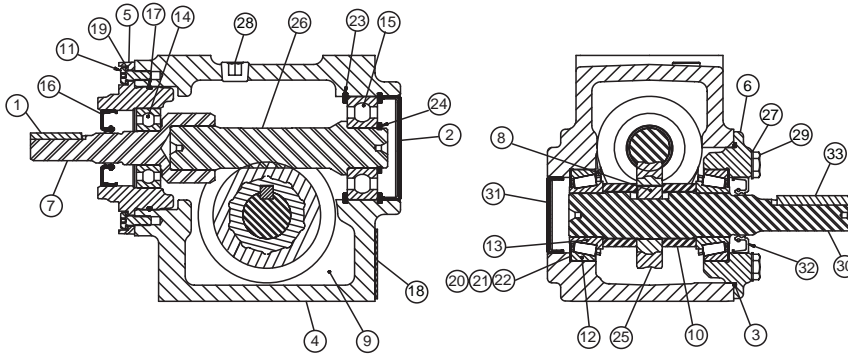

Ref No	Description	Qty	26	30	35	40	47
			Part Number	Part Number	Part Number	Part Number	Part Number
1	INPUT KEY	1	54783	54783	51744	334561	334561
2	I/P RIBBED B/P	1	334248	276004	276007	334250	334253
3	O-RING	1	334302	334308	276358	334313	334315
4	TIG2 SOLID GEARCASE	1	333215	333216	333217	334506	334576
5	T2 I/P BRG CARRIER	1	333249	333250	333253	334508	334508
6	T2 SOLID BRG HSG	1	333269	333270	333271	334510	334580
7	TIG2 INPUT COUPLING	1	See Gear Chart	See Gear Chart	See Gear Chart	See Gear Chart	See Gear Chart
8	SOLID GEAR KEY	1	333696	333706	333775	334564	334624
9	TIGEAR 2 LUBRICANT	1	334862	334862	334862	334862	334862 (2)
10	SOLID SPACER	2	333730	333731	333732	334565	334625
11	LHHC'S PLAIN	2	333807	333807	333807	333807	333807
12-13	BEARING CUP/CONE ASSM	2	411626-01-A	335338	411626-01-R	335340	335344
14	BALL BEARING	1	334213	334214	334215	334216	334216
15	BALL BEARING	1	334221	334222	334223	334224	334225
16	TIG2 INPUT SEAL	1	334272	334272	334272	334274	334274
17	O-RING, NITRILE	1	334303	334303	334314	334314	334314
18	TIGEAR 2 NAMEPLATE	1	334305	334305	334305	334305	334305
19	MED LOCKWASHER	2	419009	419009	419009	419009	419009
20-22	SHIM KIT	1	411623-33-B	335330	411623-33-C	335331	335336
23	INTERNAL RET RING	2	278715	411637-02-AC	278717	51334	51335
24	EXTERNAL RET RING	1	411637-02-AP	411637-02-AR	411637-02-BA	334404	333933
25	SOLID GEAR	1	See Gear Chart	See Gear Chart	See Gear Chart	See Gear Chart	See Gear Chart
26	WORMSHAFT	1	See Gear Chart	See Gear Chart	See Gear Chart	See Gear Chart	See Gear Chart
27	PIPE PLUG 1/4" SOC. (1)	2	411647-34-B	411647-34-B	411647-34-B	411647-34-B	411647-34-B
28	MED LOCKWASHER	4	275803	275855	275855	419036	419036
29	HEX HEAD CAP SCREW	4	51929	51952	51952	411483	411484
30	O/P SHAFT, SINGLE EXTN	1	333609	333610	333611	334554	334619
31	O/P RIBBED BORE PLUG	1	334247	334246	334254	334251	334252
32	TIG2 SEAL, OUTPUT	1	334273	334274	334275	334277	334278
33	KEY, OUTPUT	1	333695	333705	333716	55127	55127

(1) Size 400 & 475 uses qty 1

(2) Size 475 requires 266 oz. of lube. Order qty 2 (gal) 334862 & qty 1 (qt.) of 334863.

FEATURES/BENEFITS PAGE G4-2	SPECIFICATION PAGE G4-8	NOMENCLATURE PAGE G4-9	MODIFICATION/ACCESSORIES PAGE G4-90
--------------------------------	----------------------------	---------------------------	--



RENEWAL PARTS

TIGEAR-2 Separate Input / Hollow Output Sizes 13 - 23

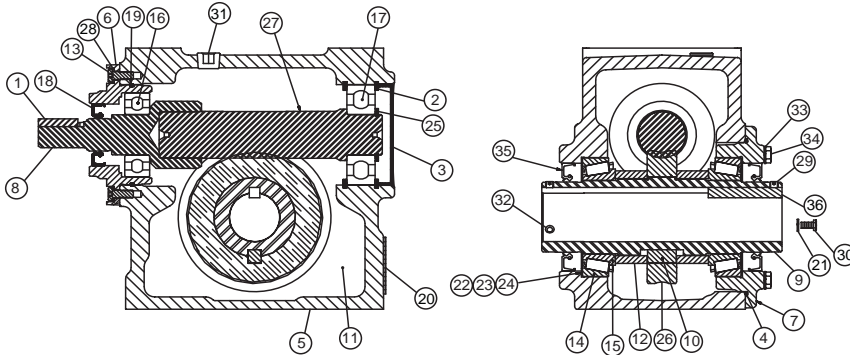

Ref No	Description	Qty	13	15	17	20	23
			Part Number	Part Number	Part Number	Part Number	Part Number
1	INPUT KEY	1	55582	55582	54783	54783	54783
2	INTERNAL RET RING	2	411637-02-AV	411637-02-AV	58256	58256	411637-01-A
3	I/P RIBBED BORE PLUG	1	276005	276005	276001	276001	276002
4	O-RING	1	276019	276019	276134	276355	334307
5	TIG2 HOLLOW GEARCASE	1	333218	333219	333220	333221	333222
6	T2 I/P BRG CARRIER	1	333245	333245	333246	333246	333249
7	T2 HOLLOW BRG HOUSING	1	333281	333281	333282	333283	333284
8	TIG2 SEP INPUT CPLG	1	See Gear Chart	See Gear Chart	See Gear Chart	See Gear Chart	See Gear Chart
9	HOLLOW OUTPUT SHAFT	1	333629	333629	333631	334789	333633
10	H/O GEAR KEY	1	333650	333650	333666	333671	333686
11	TIGEAR 2 LUBRICANT	1	334863	334863	334863	334863	334863
12	HOLLOW O/P SPACER	2	333733	333734	333735	333736	333737
13	LHCS PLAIN	2	333808	333808	333808	333808	333807
14-15	BEARING CUP/CONE ASSM	2	411626-01-A	411626-01-A	335338	335339	335340
16	BALL BEARING	1	334211	334211	334212	334212	334213
17	BALL BEARING.	1	334218	334218	334219	334219	334220
18	INPUT SEAL	1	334270	334270	334271	334271	334272
19	O-RING, NITRILE	1	334300	334300	334300	334300	334303
20	TIGEAR 2 NAMEPLATE	1	334305	334305	334305	334305	334305
21	MED LOCKWASHER	2	419007	419007	419007	419007	419009
22-24	SHIM KIT	1	411623-33-B	411623-33-B	335330	411623-33-C	335331
25	EXTERNAL RET RING	1	411637-02-E	411637-02-E	411637-02-AV	411637-02-AV	411637-02-N
26	TIG2 WORMSHAFT	1	See Gear Chart	See Gear Chart	See Gear Chart	See Gear Chart	See Gear Chart
27	TIG2 HOLLOW GEAR	1	See Gear Chart	See Gear Chart	See Gear Chart	See Gear Chart	See Gear Chart
28	MED LOCKWASHER	2	419007	419007	419007	419007	419009
29	SET SCREW	2	400140	400140	400140	400140	400140
30	HEX HEAD CAP SCREW	2	58270	58270	333800	333800	51302
31	PIPE PLUG 1/4" SOC.	2	411647-34-B	411647-34-B	411647-34-B	411647-34-B	411647-34-B
32	SET SCREW	4	275953	275953	275953	275953	275953
33	MED LOCKWASHER	4	419009	419009	419010	419010	275803
34	HEX HEAD CAP SCREW	4	51302	51302	411405	411405	51929
35	OUTPUT SEAL T2	2	334273	334273	334274	334276	334277
36	OUTPUT KEY	1	54783	54783	55025	55025	333687

RENEWAL PARTS



TIGEAR-2 Separate Input / Hollow Output Sizes 26 - 47

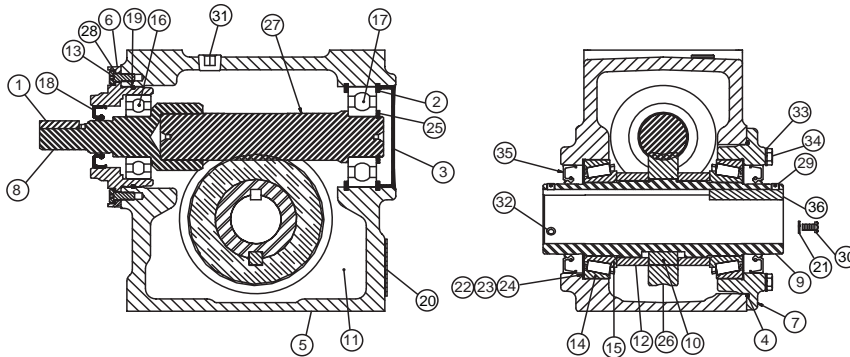

Ref No	Description	Qty	26	30	35	40	47
			Part Number	Part Number	Part Number	Part Number	Part Number
1	INPUT KEY	1	54783	54783	51744	334561	334561
2	INTERNAL RET RING	2	278715	411637-02-AC	278717	51334	51335
3	I/P RIBBED BORE PLUG	1	334248	276004	276007	334250	334253
4	O-RING	1	334302	334308	276358	334313	334315
5	TIG2 HOLLOW GEARCASE	1	333223	333224	333225	334507	334577
6	T2 I/P BRG CARRIER	1	333249	333250	333253	334508	334508
7	T2 HOLLOW BRG HOUSING	1	333285	333286	333287	334512	334582
8	TIG2 SEP INPUT CPLG	1	See Gear Chart	See Gear Chart	See Gear Chart	See Gear Chart	See Gear Chart
9	HOLLOW OUTPUT SHAFT	1	333634	333635	333636	334556	334621
10	H/O GEAR KEY	1	333670	333712	333717	334564	334624
11	TIGEAR 2 LUBRICANT	1	334862	334862	334862	334862	334862
12	HOLLOW O/P SPACER	2	333738	333739	333740	334566	334626
13	LHCS PLAIN	2	333807	333807	333807	333807	333807
14-15	BEARING CUP/CONE ASSM	2	411626-01-BJ	335341	335341	335342	335343
16	BALL BEARING	1	334213	334214	334215	334216	334216
17	BALL BEARING.	1	334221	334222	334223	334224	334225
18	INPUT SEAL	1	334272	334272	334272	334274	334274
19	O-RING, NITRILE	1	334303	334303	334314	334314	334314
20	TIGEAR 2 NAMEPLATE	1	334305	334305	334305	334305	334305
21	MED LOCKWASHER	2	419009	419009	419009	419009	419009
22-24	SHIM KIT	1	335332	335333	335333	335334	335335
25	EXTERNAL RET RING	1	411637-02-AP	411637-02-AR	411637-02-BA	334404	333933
26	TIG2 WORMSHAFT	1	See Gear Chart	See Gear Chart	See Gear Chart	See Gear Chart	See Gear Chart
27	TIG2 HOLLOW GEAR	1	See Gear Chart	See Gear Chart	See Gear Chart	See Gear Chart	See Gear Chart
28	MED LOCKWASHER	2	419009	419009	419009	419009	419009
29	SET SCREW	2	400140	400140	400140	400140	275953
30	HEX HEAD CAP SCREW	2	51302	411397	411396	411396	411402
31	PIPE PLUG 1/4" SOC.	2	411647-34-B	411647-34-B	411647-34-B	411647-34-B	411647-34-B
32	SET SCREW	4	275962	275954	275954	333805	333805
33	MED LOCKWASHER	4	275803	275855	275855	419036	419036
34	HEX HEAD CAP SCREW	4	51929	51952	51952	411483	411483
35	OUTPUT SEAL T2	2	334278	334279	334279	334280	334281
36	OUTPUT KEY	1	333687	333709	333709	334563	334623

FEATURES/BENEFITS PAGE G4-2	SPECIFICATION PAGE G4-8	NOMENCLATURE PAGE G4-9	MODIFICATION/ACCESSORIES PAGE G4-90
--------------------------------	----------------------------	---------------------------	--



RENEWAL PARTS

TIGEAR-2 Coupled Input / Solid Output Sizes 13 - 23

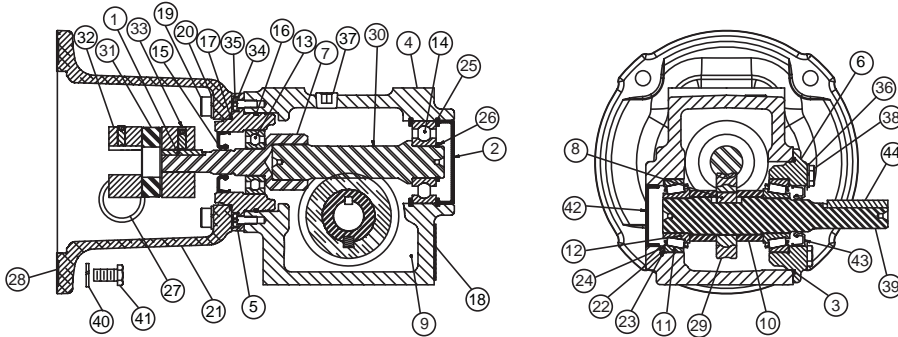

Ref No	Description	Qty	13	15	17	20	23
			Part Number	Part Number	Part Number	Part Number	Part Number
1	INPUT KEY	1	55582	55582	54783	54783	54783
2	INPUT BORE PLUG	1	276005	276005	276001	276001	276002
3	O-RING	1	276019	276019	276134	276355	334307
4	TIG2 SOLID GEARCASE	1	333210	333211	333212	333213	333214
5	T2 INPUT BRG CARRIER	1	333245	333245	333246	333246	333249
6	T2 SOLID BRG HSG	1	333265	333265	333266	333267	333268
7	TIG2 INPUT CPLG	1	See Gear Chart	See Gear Chart	See Gear Chart	See Gear Chart	See Gear Chart
8	SOLID GEAR KEY	1	333650	333661	333666	333671	333686
9	TIGEAR 2 LUBRICANT	7	334863	334863	334863	334863	334862
10	SOLID SPACER	2	333725	333726	333727	333728	333729
11-12	BEARING CUP/CONE ASSEMBLY	2	335337	335337	411626-01-C	411626-01-A	411626-01-A
13	BALL BRG. C3 CLRNC	1	334211	334211	334212	334212	334213
14	BALL BRG. C3 CLRNC	1	334218	334218	334219	334219	334220
15	TIG2 SEAL, INPUT	1	334270	334270	334271	334271	334272
16	O-RING, NITRILE	1	334300	334300	334300	334300	334303
17	O-RING, NITRILE	1	334304	334304	334304	334304	276355
18	NAMEPLATE T2	1	334305	334305	334305	334305	334305
19	CAP SCREW 56-140	4	417371	417371	417371	417371	417111
	SOCKET HEAD CAP SCR 180-210	1	-----	-----	-----	-----	-----
20	MED LOCKWASHER	4	419010	419010	419010	419010	275803
21	MOTOR ADAPTER 56-140	1	333236	333236	333236	333236	333237
	MOTOR ADAPTER	1	-----	-----	-----	-----	334683
22-24	SHIM KIT	1	411642-46-E	411642-46-E	411623-33-A	411623-33-B	411623-33-B
25	INT RING	2	411637-02-AV	411637-02-AV	58256	58256	411637-01-A
26	EXT RING	1	411637-02-E	411637-02-E	411637-02-AV	411637-02-AV	411637-02-N
27	DUST CAP 1" HOLE	1	411709-65-H	411709-65-H	411709-65-H	411709-65-H	411709-65-H
28	56/140 MTR ADPT GASKET	1	602028-43-F	602028-43-F	602028-43-F	602028-43-F	602028-43-F
	MOTOR ADPT GASKET 180-210	1	-----	-----	-----	-----	276335

FEATURES/BENEFITS PAGE G4-2	SPECIFICATION PAGE G4-8	NOMENCLATURE PAGE G4-9	MODIFICATION/ACCESSORIES PAGE G4-90
--------------------------------	----------------------------	---------------------------	--

RENEWAL PARTS



TIGEAR-2 Coupled Input / Solid Output Sizes 13 - 23

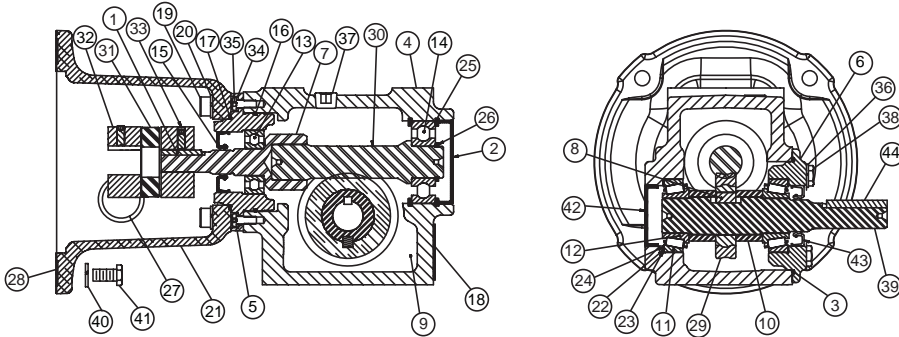

Ref No	Description	Qty	13	15	17	20	23
			Part Number	Part Number	Part Number	Part Number	Part Number
29	TIG2 SOLID GEAR	1	See Gear Chart	See Gear Chart	See Gear Chart	See Gear Chart	See Gear Chart
30	TIG2 WORMSHAFT	1	See Gear Chart	See Gear Chart	See Gear Chart	See Gear Chart	See Gear Chart
31	COUPLING SPIDER 56 MTR	1	278911	278911	278911	278911	278911
	COUPLING SPIDER 140 MTR	1	----	----	278912	278912	278912
	COUPLING SPIDER 180 MTR	1	----	----	----	----	275794
32	5/8 COUPLING, 56 MOTOR	1	278900	278900	278900	278900	278900
	7/8 COUPLING, 140 MOTOR	1	----	----	276169	276169	276169
	1-1/8 COUPLING, 180 MOTOR	1	----	----	----	----	278907
33	COUPLING HUB, REDUCER 56	1	334309	334309	278900	278900	278901
	COUPLING HUB, REDUCER 140	1	----	----	334306	334306	276169
	COUPLING HUB, REDUCER 180	1	----	----	----	----	275806
34	MED LOCKWASHER	2	419007	419007	419007	419007	419009
35	LHHCS PLAIN	2	333808	333808	333808	333808	333807
36	MED LOCKWASHER	4	419009	419009	419010	419010	275803
37	"PIPE PLUG 1/4" SOC.	2	411647-34-B	411647-34-B	411647-34-B	411647-34-B	411647-34-B
38	HEX HEAD CAP SCREW	4	51302	51302	411405	411405	51929
39	T2 SGL SOLID OUTPUT SHAFT	1	333604	333605	333606	333607	333608
40	LOCK WASHER 56-140	4	275803	275803	275803	275803	275803
	3/8-16 X 1 HHCS PLN ZC 56-140	4	51929	51929	51929	51929	51929
41	SOC HD CAP SCREW 180	4	----	----	----	----	411631-63-A
	OUTPUT BORE PLUG	1	276008	276008	334245	334247	334247
43	TIG2 SEAL, OUTPUT	1	334271	334271	334272	334273	334273
44	KEY, OUTPUT SHAFT	1	333665	333660	333665	55025	333685

FEATURES/BENEFITS PAGE G4-2	SPECIFICATION PAGE G4-8	NOMENCLATURE PAGE G4-9	MODIFICATION/ACCESSORIES PAGE G4-90
--------------------------------	----------------------------	---------------------------	--



RENEWAL PARTS

TIGEAR-2 Coupled Input / Solid Output Sizes 26 - 47

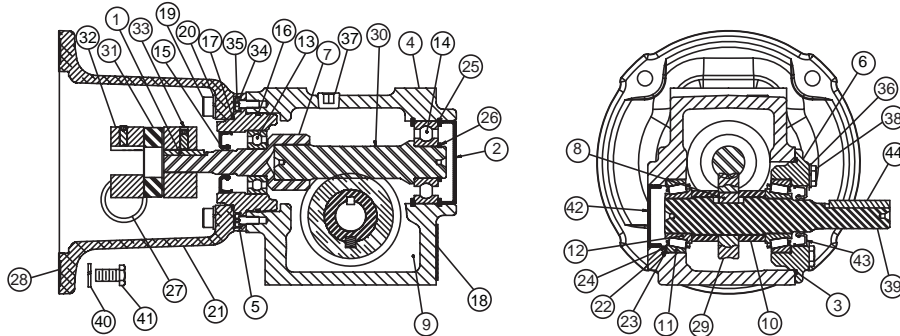

Ref No	Description	Qty	26	30	35	40	47
			Part Number	Part Number	Part Number	Part Number	Part Number
1	INPUT KEY	1	54783	54783	51744	334561	334561
2	INPUT BORE PLUG	1	334248	276004	276007	334250	334253
3	O-RING	1	334302	334308	276358	334313	334315
4	TIG2 SOLID GEARCASE	1	333215	333216	333217	334506	334576
5	T2 INPUT BRG CARRIER	1	333249	333250	333253	334508	334508
6	T2 SOLID BRG HSG	1	333269	333270	333271	334510	334580
7	TIG2 INPUT CPLG	1	See Gear Chart	See Gear Chart	See Gear Chart	See Gear Chart	334517
8	SOLID GEAR KEY	1	333696	333706	333775	334564	334624
9	TIGEAR 2 LUBRICANT	7	334862	334862	334862	334862	334862
10	SOLID SPACER	2	333730	333731	333732	334565	334625
11-12	BEARING CUP/CONE ASSEMBLY	2	411626-01-A	335338	411626-01-R	335340	335344
13	BALL BRG. C3 CLRNC	1	334213	334214	334215	334216	334216
14	BALL BRG. C3 CLRNC	1	334221	334222	334223	334224	334225
15	TIG2 SEAL, INPUT	1	334272	334272	334272	334274	334274
16	O-RING, NITRILE	1	334303	334303	334314	334314	334314
17	O-RING, NITRILE	1	276355	276355	276355	276355	276355
18	NAMEPLATE T2	1	334305	334305	334305	334305	334305
19	CAP SCREW 56-140	4	417111	417111	334895	-----	-----
	SOCKET HEAD CAP SCR 180-210	1	-----	-----	334373	334373	334373
20	MED LOCKWASHER	4	275803	275803	275855	333783	333783
	MOTOR ADAPTER 56-140	1	333237	333237	334757	-----	-----
	MOTOR ADAPTER 180	1	334683	334683	333239	333239	333239
	MOTOR ADPT PLT-BOLT ON 210 (2)	1	-----	-----	334571	334571	334571
	MOTOR ADPT PLT-BOLT ON 250 (2)	1	-----	-----	-----	334570	334570
22-24	SHIM KIT	1	411623-33-B	335330	411623-33-C	335331	335336
25	INT RING	2	278715	411637-02-AC	278717	51334	51335
26	EXT RING	1	411637-02-AP	411637-02-AR	411637-02-BA	334404	333933
27	DUST CAP 1" HOLE	1	411709-65-H	411709-65-H	411709-65-H	411709-65-H	411709-65-H
28	56/140 MTR ADPT GASKET	1	602028-43-F	602028-43-F	602028-43-F	-----	-----
	MOTOR ADPT GASKET 180-210	1	276335	276335	276335	276335	276335

(2) Adapter plate bolts onto 180 adapter 334683.

FEATURES/BENEFITS PAGE G4-2	SPECIFICATION PAGE G4-8	NOMENCLATURE PAGE G4-9	MODIFICATION/ACCESSORIES PAGE G4-90
--------------------------------	----------------------------	---------------------------	--

RENEWAL PARTS



TIGEAR-2 Coupled Input / Solid Output Sizes 26 - 47

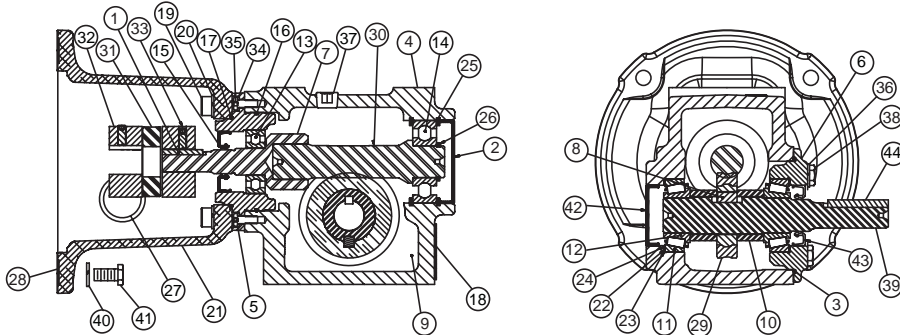

Ref No	Description	Qty	26	30	35	40	47
			Part Number	Part Number	Part Number	Part Number	Part Number
29	TIG2 SOLID GEAR	1	See Gear Chart	See Gear Chart	See Gear Chart	See Gear Chart	See Gear Chart
30	TIG2 WORMSHAFT	1	See Gear Chart	See Gear Chart	See Gear Chart	See Gear Chart	See Gear Chart
31	COUPLING SPIDER 56 MTR	1	278911	278911	278912	----	----
	COUPLING SPIDER 140 MTR	1	278912	278912	278912	----	----
	COUPLING SPIDER 180 MTR	1	275794	275794	275794	275794	275794
	COUPLING SPIDER 210-250 MTR	1	----	----	334291	334291	334291
32	5/8 COUPLING, 56 MOTOR	1	278900	278900	334292	----	----
	7/8 COUPLING, 140 MOTOR	1	276169	276169	276169	----	----
	1-1/8 COUPLING, 180 MOTOR	1	278907	278907	278907	278907	278907
	1-3/8 COUPLING, 210 MOTOR	1	----	----	334286	334286	334286
	1-3/8 COUPLING, 250 MOTOR	1	----	----	----	334288	334288
33	COUPLING HUB, REDUCER 56	1	278901	278901	276169	----	----
	COUPLING HUB, REDUCER 140	1	276169	276169	276169	----	----
	COUPLING HUB, REDUCER 180	1	275806	275806	275806	278907	278907
	COUPLING HUB, REDUCER 210-250	1	----	----	334285	334290	334290
34	MED LOCKWASHER	2	419009	419009	419009	419009	419009
35	LHHCS PLAIN	2	333807	333807	333807	333807	333807
36	MED LOCKWASHER	4	275803	275855	275855	419036	419036
37	PIPE PLUG 1/4" SOC.	2	411647-34-B	411647-34-B	411647-34-B	411647-34-B	411647-34-B
38	HEX HEAD CAP SCREW	4	51929	51952	51952	411483	411484
39	T2 SGL SOLID OUTPUT SHAFT	1	333609	333610	333611	334554	334619
40	LOCK WASHER 56-140	4	275803	275803	275803	----	----
	LOCK WASHER 210-250	4	----	----	275853	275853	275853
41	3/8-16 X 1 HHCS PLN ZC 56-140	4	51929	51929	51929	----	----
	SOC HD CAP SCREW 180	4	411631-63-A	411631-63-A	411631-58-X	411631-58-X	411631-58-X
	HEX HD CAP SCREW 210	4	----	----	275845	275845	275845
	HEX HD CAP SCREW 250	4	----	----	----	276447	276447
42	OUTPUT BORE PLUG	1	334247	334246	334254	334251	334252
43	TIG2 SEAL, OUTPUT	1	334273	334274	334275	334277	334278
44	KEY, OUTPUT SHAFT	1	333695	333705	333716	55127	55127

FEATURES/BENEFITS PAGE G4-2	SPECIFICATION PAGE G4-8	NOMENCLATURE PAGE G4-9	MODIFICATION/ACCESSORIES PAGE G4-90
--------------------------------	----------------------------	---------------------------	--



RENEWAL PARTS

TIGEAR-2 Coupled Input / Hollow Output Sizes 13 - 23

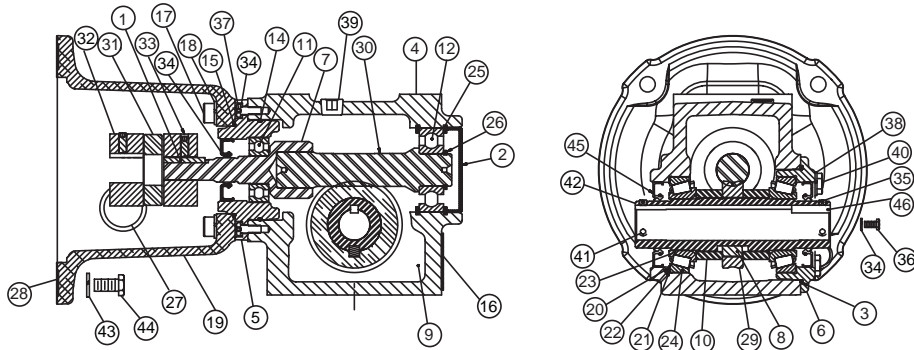

Ref No	Description	Qty	13	15	17	20	23
			Part Number	Part Number	Part Number	Part Number	Part Number
1	INPUT KEY	1	55582	55582	54783	54783	54783
2	INPUT BORE PLUG	1	276005	276005	276001	276001	276002
3	O-RING	1	276019	276019	276134	276355	334307
4	TIG2 HOLLOW GEARCASE	1	333218	333219	333220	333221	333222
5	T2 I/P BRG CARRIER	1	333245	333245	333246	333246	333249
6	T2 HOLLOW BRG HOUSING	1	333281	333281	333282	333283	333284
7	TIG2 SEP INPUT CPLG	1	See Gear Chart	See Gear Chart	See Gear Chart	See Gear Chart	See Gear Chart
8	GEAR KEY	1	333650	333650	333666	333671	333686
9	TIGEAR 2 LUBRICANT	1	334863	334863	334863	334863	334863
10	TIG2 HOLLW O/P SPACER	2	333733	333734	333735	333736	333737
11	BALL BEARING	1	334211	334211	334212	334212	334213
12	BALL BEARING	1	334218	334218	334219	334219	334220
13	TIG2 SEAL, INPUT	1	334270	334270	334271	334271	334272
14	O-RING, NITRILE	1	334300	334300	334300	334300	334303
15	O-RING, NITRILE	1	334304	334304	334304	334304	276355
16	NAMEPLATE T2	1	334305	334305	334305	334305	334305
17	CAD PLTD SCREW 56-140	4	417371	417371	417371	417371	417111
	CAD PLTD SCREW 180-210-250	4	----	----	----	----	----
18	MED LOCKWASHER	4	419010	419010	419010	419010	275803
19	T2 ADPT. M. ADPTR 56-140	1	333236	333236	333236	333236	333237
	MOTOR ADAPTER 180	1	----	----	----	----	334683
20-22	SHIM KIT	1	411623-33-B	411623-33-B	335330	411623-33-C	335331
23-24	BEARING CUP/CONE ASSEMBLY	2	411626-01-A	411626-01-A	335338	335339	335340
25	INT RING	2	411637-02-AV	411637-02-AV	58256	58256	411637-01-A
26	EXT RING	1	411637-02-E	411637-02-E	411637-02-AY	411637-02-AY	411637-02-N
27	DUST CAP 1" HOLE	1	411709-65-Q	411709-65-Q	411709-65-Q	411709-65-Q	411709-65-Q
28	56/140 M/A. GASKET	1	602028-43-F	602028-43-F	602028-43-F	602028-43-F	602028-43-F
	MOTOR GASKET 180-210	1	----	----	----	----	276335
29	TIG2 HOLLOW GEAR	1	See Gear Chart	See Gear Chart	See Gear Chart	See Gear Chart	See Gear Chart
30	TIG2 WORMSHAFT	1	See Gear Chart	See Gear Chart	See Gear Chart	See Gear Chart	See Gear Chart

FEATURES/BENEFITS PAGE G4-2	SPECIFICATION PAGE G4-8	NOMENCLATURE PAGE G4-9	MODIFICATION/ACCESSORIES PAGE G4-90
--------------------------------	----------------------------	---------------------------	--

RENEWAL PARTS



TIGEAR-2 Coupled Input / Hollow Output Sizes 13 - 23

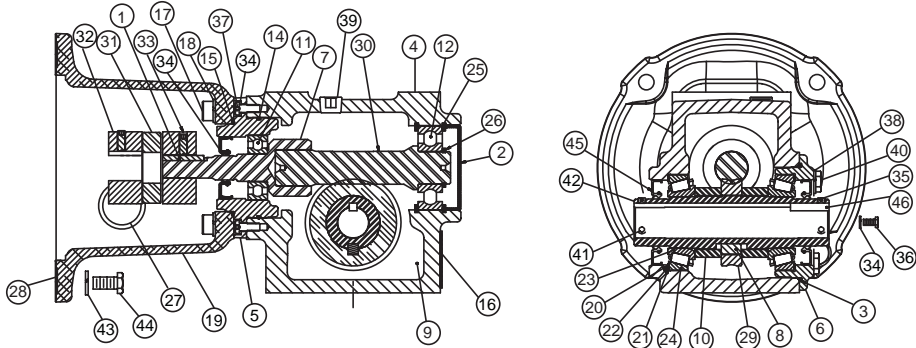

Ref No	Description	Qty	13	15	17	20	23
			Part Number	Part Number	Part Number	Part Number	Part Number
31	SPIDER 56C	1	278911	278911	278911	278911	278911
	SPIDER 140TC	1	-----	-----	278912	278912	278912
	SPIDER 180TC	1	-----	-----	-----	-----	275794
32	5/8 COUPLING HUB-MOTOR 56C	1	278900	278900	278900	278900	278900
	7/8 COUPLING HUB-MOTOR 140TC	1	-----	-----	276169	276169	276169
	1-1/8 COUPLING HUB-MTR 180TC	1	-----	-----	-----	-----	278907
33	COUPLING - REDUCER 56C	1	334309	334309	278900	278900	278901
	COUPLING - REDUCER 140TC	1	-----	-----	334306	334306	276169
	COUPLING - REDUCER 180TC	1	-----	-----	-----	-----	275806
34	MED LOCKWASHER	4	419007	419007	419007	419007	419009
35	SET SCREW	2	400140	400140	400140	400140	400140
36	HHCS GR5 ZC	2	58270	58270	333800	333800	51302
37	LHHCS PLAIN	2	333808	333808	333808	333808	333807
38	MED LOCKWASHER	4	419009	419009	419010	419010	275803
39	"PIPE PLUG 1/4" SOC.	2	411647-34-B	411647-34-B	411647-34-B	411647-34-B	411647-34-B
40	HEX HEAD CAP SCREW	4	51302	51302	411405	411405	51929
41	SET SCREW	4	275953	275953	275953	275953	275953
42	HOLLOW OUTPUT SHAFT	1	333629	333629	333631	334789	333633
43	LOCK WASHER 56-140	4	275803	275803	275803	275803	275803
44	3/8-16 X 1 HHCS PLN ZC 56-140	4	51929	51929	51929	51929	51929
	SOCKET HEAD CAP SCR 180	4	-----	-----	-----	-----	411631-63-A
45	SEAL TIGEAR 2, OUTPUT	2	334273	334273	334274	334276	334277
46	OUTPUT KEY	2	54783	54783	55025	55025	333687

FEATURES/BENEFITS PAGE G4-2	SPECIFICATION PAGE G4-8	NOMENCLATURE PAGE G4-9	MODIFICATION/ACCESSORIES PAGE G4-90
--------------------------------	----------------------------	---------------------------	--



RENEWAL PARTS

TIGEAR-2 Coupled Input / Hollow Output Sizes 26 - 47

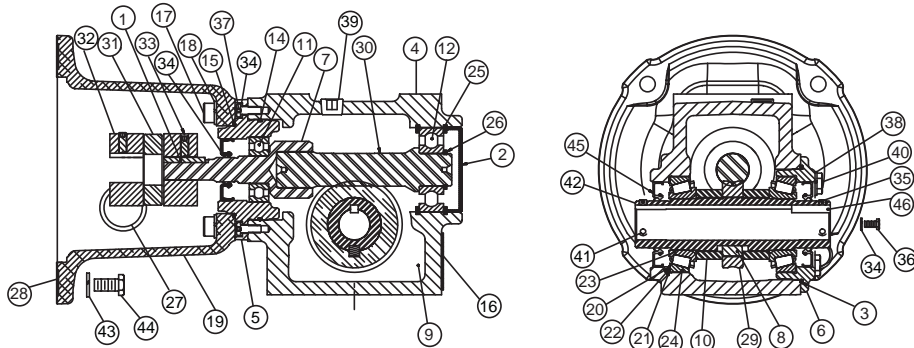

Ref No	Description	Qty	26	30	35	40	47
			Part Number	Part Number	Part Number	Part Number	Part Number
1	INPUT KEY	1	54783	54783	51744	334561	334561
2	INPUT BORE PLUG	1	334248	276004	276007	334250	334253
3	O-RING	1	334302	334308	276358	334313	334315
4	TIG2 HOLLOW GEARCASE	1	333223	333224	333225	334507	334577
5	T2 I/P BRG CARRIER	1	333249	333250	333253	334508	334508
6	T2 HOLLOW BRG HOUSING	1	333285	333286	333287	334512	334582
7	TIG2 SEP INPUT CPLG	1	See Gear Chart	See Gear Chart	See Gear Chart	See Gear Chart	See Gear Chart
8	GEAR KEY	1	333670	333712	333717	334564	334624
9	TIGEAR 2 LUBRICANT	1	334862	334862	334862	334862	334862
10	TIG2 HOLLW O/P SPACER	2	333738	333739	333740	334566	334626
11	BALL BEARING	1	334213	334214	334215	334216	334216
12	BALL BEARING	1	334221	334222	334223	334224	334225
13	TIG2 SEAL, INPUT	1	334272	334272	334272	334274	334274
14	O-RING, NITRILE	1	334303	334303	334314	334314	334314
15	O-RING, NITRILE	1	276355	276355	276355	276355	276355
16	NAMEPLATE T2	1	334305	334305	334305	334305	334305
17	CAD PLTD SCREW 56-140	4	417111	417111	334895	-----	-----
17	CAD PLTD SCREW 180-210-250	4	-----	-----	334373	334373	334373
18	MED LOCKWASHER	4	275803	275803	275855	333783	333783
19	T2 ADPT. M. ADPTR 56-140	1	333237	333237	334757	-----	-----
	MOTOR ADPT PLT 180-210 (1)	1	334683	334683	333239	333239	333239
	MTR ADPT PLT-BOLT ON 210 (2)	1	-----	-----	334571	334571	334571
	MTR ADPT PLT-BOLT ON 250 (2)	1	-----	-----	-----	334570	334570
20-22	SHIM KIT	1	335332	335333	335333	335334	335335
23-24	BEARING CUP/CONE ASSEMBLY	2	41162601BJ	335341	335341	335342	335343
25	INT RING	2	278715	411637-02-AC	278717	51334	51335
26	EXT RING	1	411637-02-AP	411637-02-AR	411637-02-BA	334404	333933
27	DUST CAP 1" HOLE	1	411709-65-Q	411709-65-Q	411709-65-Q	411709-65-Q	411709-65-Q
28	56/140 M/A. GASKET	1	602028-43-F	602028-43-F	602028-43-F	-----	-----
28	MOTOR GASKET 180-210	1	276335	276335	276335	276335	276335
29	TIG2 HOLLOW GEAR	1	See Gear Chart	See Gear Chart	See Gear Chart	See Gear Chart	See Gear Chart
30	TIG2 WORMSHAFT	1	See Gear Chart	See Gear Chart	See Gear Chart	See Gear Chart	See Gear Chart

(2) Adpt plate bolts onto 180 adpt 333239.

FEATURES/BENEFITS PAGE G4-2	SPECIFICATION PAGE G4-8	NOMENCLATURE PAGE G4-9	MODIFICATION/ACCESSORIES PAGE G4-90
--------------------------------	----------------------------	---------------------------	--

RENEWAL PARTS



TIGEAR-2 Coupled Input / Hollow Output Sizes 26 - 47

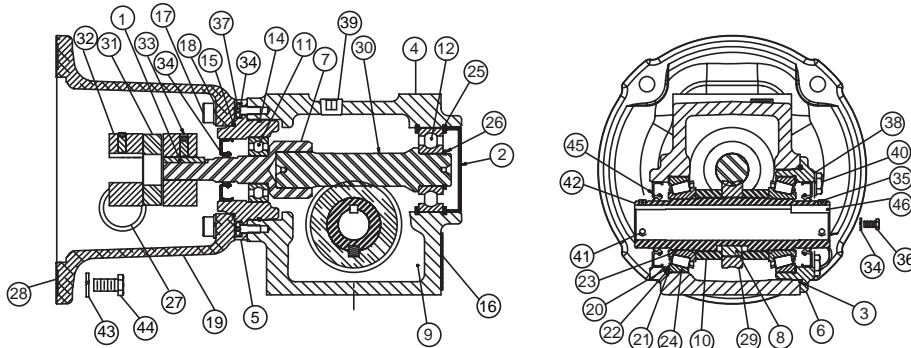

Ref No	Description	Qty	26	30	35	40	47
			Part Number	Part Number	Part Number	Part Number	Part Number
31	SPIDER 56C	1	278911	278911	-----	-----	-----
	SPIDER 140TC	1	278912	278912	278912	278907	-----
	SPIDER 180TC	1	275794	275794	275794	275794	275794
	SPIDER 210-250	1	-----	-----	334291	334291	334291
32	5/8 COUPLING HUB-MOTOR 56C	1	278900	278900	-----	-----	-----
	7/8 COUPLING HUB-MOTOR 140TC	1	276169	276169	276169	-----	-----
	1-1/8 COUPLING HUB-MTR 180TC	1	278907	278907	278907	278907	278907
	1-3/8 COUPLING HUB-MTR 210TC	1	-----	-----	334286	334286	334286
	1-5/8 COUPLING HUB-MTR 250TC	1	-----	-----	-----	334288	334288
33	COUPLING - REDUCER 56C	1	278901	278901	-----	-----	-----
	COUPLING - REDUCER 140TC	1	276169	276169	276169	-----	-----
	COUPLING - REDUCER 180TC	1	275806	275806	275806	278907	278907
	COUPLING - REDUCER 210-250	1	-----	-----	334285	334290	334290
34	MED LOCKWASHER	4	419009	419009	419009	419009	419009
35	SET SCREW	2	400140	400140	400140	400140	275953
36	HHCS GR5 ZC	2	51302	411397	411396	411396	411402
37	LHHCS PLAIN	2	333807	333807	333807	333807	333807
38	MED LOCKWASHER	4	275803	275855	275855	419036	419036
39	PIPE PLUG 1/4" SOC.	2	411647-34-B	411647-34-B	411647-34-B	411647-34-B	411647-34-B
40	HEX HEAD CAP SCREW	4	51929	51952	51952	411483	411484
41	SET SCREW	4	275962	275954	275954	333805	333805
42	HOLLOW OUTPUT SHAFT	1	333634	333635	333636	334556	334621
43	LOCK WASHER 56-140	4	275803	275803	275803	-----	-----
	LOCK WASHER 210	4	-----	-----	275853	275853	275853
	LOCK WASHER 250	4	-----	-----	-----	275853	275853
44	3/8-16 X 1 HHCS PLN ZC 56-140	4	51929	51929	51929	-----	-----
	SOCKET HEAD CAP SCR 180	4	411631-63-A	411631-63-A	411631-58-X	411631-58-X	411631-58-X
	HEX HD CAP SCREW 210	4	-----	-----	275845	275845	275845
	HEX HD CAP SCREW 250	4	-----	-----	-----	276447	276447
45	SEAL TIGEAR 2, OUTPUT	2	334278	334279	334279	334280	334281
46	OUTPUT KEY	2	333687	333709	333709	334563	334623

FEATURES/BENEFITS PAGE G4-2	SPECIFICATION PAGE G4-8	NOMENCLATURE PAGE G4-9	MODIFICATION/ACCESSORIES PAGE G4-90
--------------------------------	----------------------------	---------------------------	--

NOTES

FEATURES/BENEFITS PAGE G4-2	SPECIFICATION PAGE G4-8	NOMENCLATURE PAGE G4-9	MODIFICATION/ACCESSORIES PAGE G4-90
--------------------------------	----------------------------	---------------------------	--

CONTENTS



Combination TIGEAR

Features/Benefits	G5-2
Specifications	G5-4
How To Order	G5-5
Nomenclature	G5-5
Easy Selection	G5-6
Selection/Service Factor Tables	G5-13
Dimensions	G5-24
Mouting Positions	G5-32
Modification/Accessories	G5-34
Renewal Parts.	G5-45
Engineering/Technical.	G5-52
Part Number Index	INDEX-1
Keyword Index	INDEX-27

Combination TIGEAR

Engineering

System-1

Index

FEATURES/BENEFITS



DODGE Combination TIGEAR

A WORM-HELICAL REDUCER DESIGNED WITH FLEXIBILITY AND MAINTENANCE IN MIND

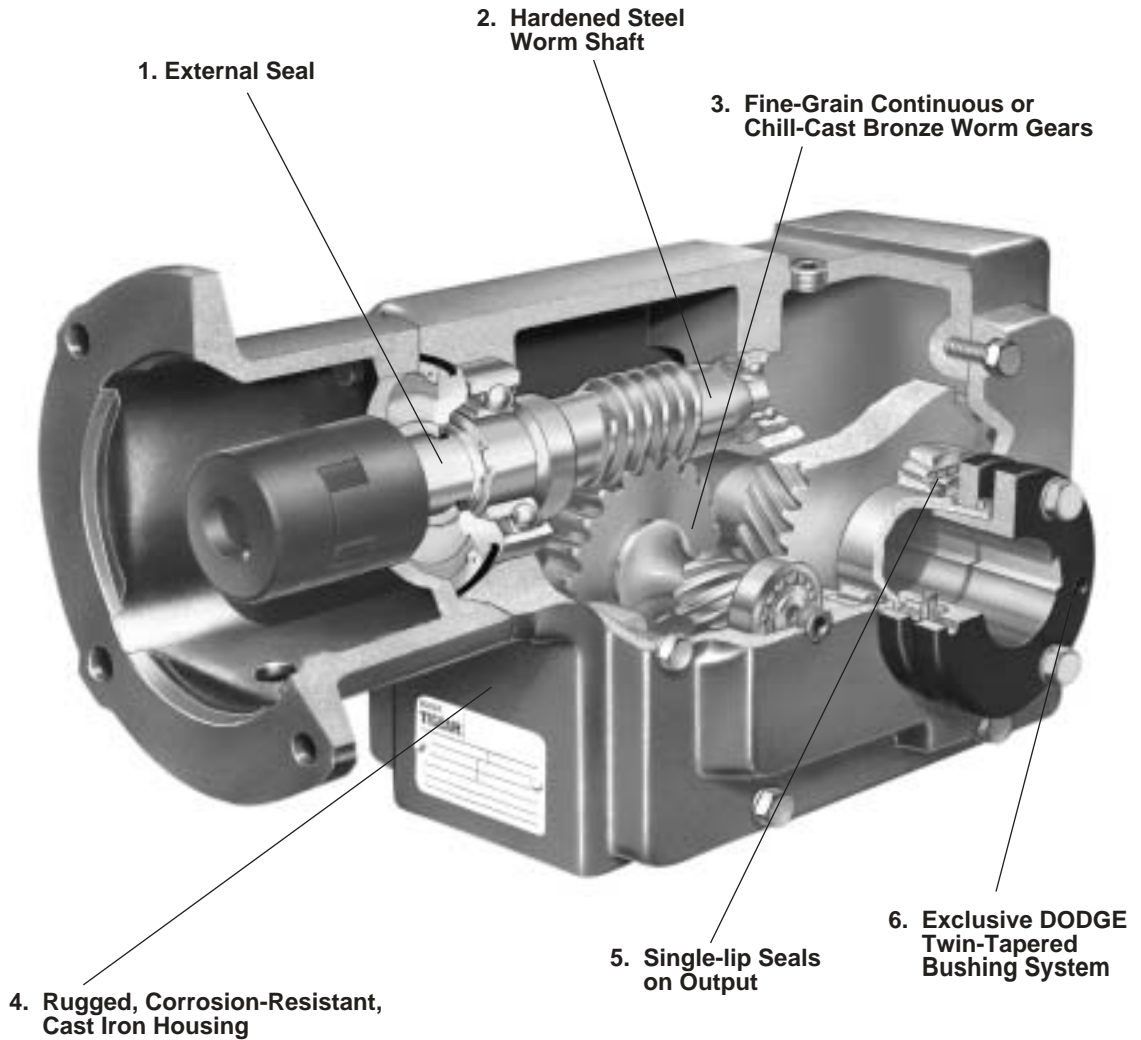

FEATURES/BENEFITS



DODGE Combination TIGEAR

1. External single lip seal. Runs on precision, plunge ground, 10-20 RMS journal surface
2. Motor adapter removal permits easy access to input worm shaft. Assures simple seal and/or bearing replacement.
3. These worm gears feature copper tin alloy for superior wear resistance, a computer designed gear geometry, and an optimized gear contact pattern for reduced break-in time and maximum thermal performance.
4. A rugged, cast iron housing ensures long years of service, even in corrosive environments. Each model has interchangeable, optional bolt-on feet, which allow industry-standard mounting dimensions.
5. Single lip seals reduce drag on the output shaft for improved efficiency. The plunge ground, 10-20 RMS seal journal surface provides a smooth finish for optimum seal performance.
6. Exclusive twin tapered bushing system provides positive concentric grip on both sides of the reducer. It eliminates wobble, eccentricity, and assures easy installation and removal.

PROVEN RELIALUBE SYSTEM REQUIRES NO PERIODIC MAINTENANCE.

- Factory-filled, synthesized hydrocarbon lubricant
- Ambient operating temperature range (-10°F through 165°F)
- No open path to the environment
- No conventional vent plugs
- Minimized seepage and contamination paths
- Complete cast iron gearcase

SPECIFICATION



Combination TIGEAR

The speed reducer shall be a double reduction unit incorporating an input worm set and a helical output set. Motor coupling shall be provided by a 3 piece coupling configuration. The reducer shall be manufactured in the United States of America. Wormgear geometry shall be a single enveloping helicoid design. The gearcase, bearing housings, and motor adaptor shall be manufactured from Class 30 gray iron. A bolt on foot shall be available. Output configurations offered shall be solid shaft, hollow shaft straight bore, or hollow shaft with twin tapered bushings.

The reducer shall be sealed with no direct passage from the oil sump to the ambient atmosphere. Lubrication shall be a factory supplied synthesized hydrocarbon that requires no periodic changes and is filled to a level suitable for the mounting position specified on the order. If no mounting position is specified, the oil level is appropriate for K-1/L-1 only. USDA Class AA, Class H1 food grade, and low temperature lubricants shall be available to accommodate different applications.

The input worm set shall consist of a hardened steel worm shaft and a copper-tin bronze alloy wormgear for superior

wear resistance. All units shall have the wormgear set properly centered during assembly to produce an optimum contact pattern. The contact pattern of each set shall be manually checked to ensure that the optimum pattern is present. The output gearset set shall be of an involute helical design with case carburized gear teeth. Output shafts shall incorporate tapered roller bearings shimmed for proper running clearances. Seals shall have a rubber coated O.D. and operate on plunge ground journals having a 10-20 μ in. finish. Joints shall be sealed with a silicon rubber or anaerobic sealant. No gaskets or O-rings shall be used. All fasteners shall be minimum grade 8.8 metric. Motor mounting bolts and input/output keys shall be provided.

The standard construction shall be suitable for duty in ambient temperatures from -10°F to +165°F. When used without the bolt-on foot, the reducer shall be BISSC certified. Severe operating conditions shall be addressed with a Nylon 11 coated gearcase incorporating stainless steel hardware and nickel plated output shaft extensions or teflon coated twin tapered bushings.

FEATURES/BENEFITS PAGE G5-2	NOMENCLATURE PAGE G5-5	DIMENSIONS PAGE G5-24	MODIFICATION/ACCESSORIES PAGE G5-34
--------------------------------	---------------------------	--------------------------	--



Combination TIGEAR HOW TO ORDER TIGEAR REDUCERS

All TIGEAR reducers and accessories have a part number. Reducer part numbers are found in the selection tables and the accessories are listed in the modification section of this catalog. Refer to the part numbers when ordering and specify the reducer part number along with the part numbers of the required accessories.

140C200T025S1A 140TC C-Face, Size C200, 25:1, Taper Hollow Shaft (Page G5-17)
6002503 Size C200 Tie Rod Kit (Page G5-35)

NEW TIGEAR NOMENCLATURE

MOTOR FRME	SERIES		SIZE	OUTPUT TYPE	RATIO	SHAFT POSITON
056	C	COMBINATION	150	B BASIC UNIT STD SHAFT	010 015	L1
140			200	S SHAFT MOUNT STRAIGHT BORE	018 020 025 030 038	K1 LK
180			262		040 050 060 075 080 090 100 125 150 160 200 240 300	S1
210			350	T SHAFT MOUNT TWIN TAPERED		



Combination TIGEAR

COMBINATION TIGEAR EASY SELECTION TABLES

In the following tables, Combination TIGEAR reducers have been pre-selected for standard motor horsepowers at commonly applied service factors. All selections are for 1750 rpm motors. For selections at other motor speeds refer to the selection procedure using the rating tables. Each block in the selection table provides the following information:

- **Gearcase Size** Worm set center distance. For example, a C150 has a 1.50" worm center distance.
- **Output Torque** Torque that will be produced at the output shaft when the particular motor is loaded to its nameplate rated horsepower.
- **Output OHL** The continuous overhung load that may be applied to the output shaft at one shaft diameter from the seal face.

Two methods are available to the designer using the selection tables. The horsepower method, applied in cases where motor horsepower is known, is useful when interchanging with a competitive unit or utilizing an

available motor. The torque method requires the knowledge of driven load requirement and provides the most economical reducer selection. Both methods assume the desired ratio or output rpm is known.

HORSEPOWER METHOD OF SELECTION

- Step 1:** Referring to the reducer service factor table, determine the appropriate service factor.
- Step 2:** Locate the selection table configured for the required service factor.
- Step 3:** Read down from motor horsepower and across from rpm/ratio to locate the appropriate selection block.

TORQUE METHOD OF SELECTION

- Step 1:** Referring to the reducer service factor table, determine the appropriate service factor.
- Step 2:** Locate the selection table configured for the required service factor.
- Step 3:** Find the row that represents the applicable output rpm/ratio and read across the torque line until the torque value equals or exceeds driven load requirements.
- Step 4:** Read up from the selection block to determine required motor horsepower.



Combination TIGEAR

1.00 REDUCER SERVICE FACTOR 1750 RPM INPUT

RPM OUT	NOM. RATIO*	MOTOR HORSEPOWER												
		SIZE	0.25	0.33	0.50	0.75	1	1.50	2	3	5	7.50	10	
156	10	SIZE	150	150	150	150	150	150	150	200	200	262	350	350
		Torque	68 lb in	96 lb in	157 lb in	247 lb in	336 lb in	515 lb in	723 lb in	1096 lb in	1861 lb in	2767 lb in	3706 lb in	3706 lb in
		OHL	896 lb	896 lb	896 lb	896 lb	896 lb	896 lb	896 lb	1306 lb	1306 lb	2220 lb	4653 lb	4653 lb
125	15	SIZE	150	150	150	150	150	150	150	200	200	262	350	350
		Torque	85 lb in	121 lb in	198 lb in	310 lb in	423 lb in	648 lb in	893 lb in	1353 lb in	2285 lb in	3417 lb in	4576 lb in	4576 lb in
		OHL	910 lb	910 lb	910 lb	910 lb	910 lb	910 lb	910 lb	1325 lb	1325 lb	2283 lb	4726 lb	4726 lb
105	18	SIZE	150	150	150	150	150	150	150	200	200	262	350	350
		Torque	102 lb in	145 lb in	236 lb in	371 lb in	505 lb in	774 lb in	1066 lb in	1615 lb in	2729 lb in	4079 lb in	5463 lb in	5463 lb in
		OHL	920 lb	920 lb	920 lb	920 lb	920 lb	920 lb	920 lb	1339 lb	1339 lb	2371 lb	4785 lb	4785 lb
86	20	SIZE	150	150	150	150	150	150	150	200	200	262	350	350
		Torque	124 lb in	176 lb in	288 lb in	451 lb in	614 lb in	941 lb in	1297 lb in	1965 lb in	3320 lb in	4963 lb in	6647 lb in	6647 lb in
		OHL	930 lb	930 lb	930 lb	930 lb	930 lb	930 lb	930 lb	1352 lb	1352 lb	2436 lb	4800 lb	4800 lb
69	25	SIZE	150	150	150	150	150	150	150	200	200	262	350	350
		Torque	155 lb in	220 lb in	359 lb in	563 lb in	768 lb in	1176 lb in	1620 lb in	2455 lb in	4148 lb in	6201 lb in	8304 lb in	8304 lb in
		OHL	938 lb	938 lb	938 lb	938 lb	938 lb	938 lb	938 lb	1361 lb	1361 lb	2491 lb	4717 lb	4717 lb
58	30	SIZE	150	150	150	150	150	150	200	200	262	350	350	
		Torque	189 lb in	266 lb in	430 lb in	672 lb in	914 lb in	1411 lb in	1901 lb in	2902 lb in	4872 lb in	7368 lb in		
		OHL	970 lb	970 lb	970 lb	970 lb	970 lb	970 lb	1410 lb	1410 lb	2751 lb	4925 lb	4925 lb	
46	38	SIZE	150	150	150	150	150	150	200	200	262	350	350	
		Torque	236 lb in	332 lb in	538 lb in	840 lb in	1142 lb in	1763 lb in	2376 lb in	3625 lb in	6087 lb in	9205 lb in		
		OHL	979 lb	979 lb	979 lb	979 lb	979 lb	979 lb	1421 lb	1421 lb	2781 lb	4823 lb	4823 lb	
43	40	SIZE	150	150	150	150	150	150	200	200	262	350		
		Torque	246 lb in	346 lb in	560 lb in	875 lb in	1190 lb in	1849 lb in	2489 lb in	3804 lb in	6397 lb in			
		OHL	981 lb	981 lb	981 lb	981 lb	981 lb	981 lb	1423 lb	1423 lb	2786 lb	5197 lb		
35	50	SIZE	150	150	150	150	150	150	200	200	262	350		
		Torque	307 lb in	433 lb in	700 lb in	1093 lb in	1487 lb in	2310 lb in	3109 lb in	4753 lb in	7992 lb in			
		OHL	985 lb	985 lb	985 lb	985 lb	985 lb	985 lb	1425 lb	1425 lb	2805 lb	5154 lb		
29	60	SIZE	150	150	150	150	200	200	200	262	350	350		
		Torque	360 lb in	504 lb in	811 lb in	1261 lb in	1746 lb in	2665 lb in	3647 lb in	5504 lb in	9300 lb in			
		OHL	1013 lb	1013 lb	1013 lb	1013 lb	1472 lb	1472 lb	2910 lb	5064 lb	5064 lb			

* Refer to page G5-55 for exact ratio

FEATURES/BENEFITS PAGE G5-2	SPECIFICATION PAGE G5-4	NOMENCLATURE PAGE G5-5	MODIFICATION/ACCESSORIES PAGE G5-34
--------------------------------	----------------------------	---------------------------	--

EASY SELECTION



Combination TIGEAR

1.00 REDUCER SERVICE FACTOR 1750 RPM INPUT

RPM OUT	NOM. RATIO*	MOTOR HORSEPOWER											
			0.25	0.33	0.50	0.75	1	1.50	2	3	5	7.50	10
23	75	SIZE	150	150	150	150	200	200	262	350	350		
		Torque	450 lb in	630 lb in	1012 lb in	1575 lb in	2181 lb in	3329 lb in	4556 lb in	6876 lb in	11619 lb in		
		OHL	1020 lb	1020 lb	1020 lb	1020 lb	1470 lb	1470 lb	2933 lb	5501 lb	5501 lb		
22	80	SIZE	150	150	150	150	200	262	350	350			
		Torque	466 lb in	648 lb in	1034 lb in	1603 lb in	2231 lb in	3398 lb in	4642 lb in	7073 lb in			
		OHL	1023 lb	1023 lb	1023 lb	1023 lb	1537 lb	2932 lb	5542 lb	5542 lb			
19	90	SIZE	150	150	150	200	200	262	350	350			
		Torque	548 lb in	763 lb in	1222 lb in	1863 lb in	2529 lb in	3373 lb in	4646 lb in	7078 lb in			
		OHL	1063 lb	1063 lb	1063 lb	1542 lb	1542 lb	2937 lb	5481 lb	5481 lb			
17	100	SIZE	150	150	150	200	200	262	350	350			
		Torque	582 lb in	810 lb in	1292 lb in	2057 lb in	2787 lb in	4057 lb in	5800 lb in	8836 lb in			
		OHL	1070 lb	1070 lb	1070 lb	1544 lb	1544 lb	2937 lb	5462 lb	5462 lb			
14	125	SIZE	150	150	150	200	200	262	350	350			
		Torque	626 lb in	868 lb in	1383 lb in	2490 lb in	3372 lb in	4936 lb in	7062 lb in	10759 lb in			
		OHL	1081 lb	1081 lb	1081 lb	1545 lb	1545 lb	3039 lb	5339 lb	5339 lb			
12	150	SIZE	150	150	150	200	262	262	350	350			
		Torque	783 lb in	1085 lb in	1728 lb in	2792 lb in	4037 lb in	6151 lb in	8248 lb in	12567 lb in			
		OHL	1082 lb	1082 lb	1082 lb	1607 lb	3051 lb	3051 lb	5207 lb	5207 lb			
11	160	SIZE	150	150	200	200	262	262	350				
		Torque	796 lb in	1100 lb in	1823 lb in	2813 lb in	3946 lb in	6002 lb in	8146 lb in				
		OHL	1133 lb	1133 lb	1667 lb	1667 lb	3195 lb	3195 lb	5829 lb				
8.60	200	SIZE	150	150	200	200	262	350	350				
		Torque	995 lb in	1374 lb in	2277 lb in	3514 lb in	4930 lb in	7526 lb in	10177 lb in				
		OHL	1142 lb	1142 lb	1681 lb	1681 lb	3220 lb	5766 lb	5766 lb				
7.20	240	SIZE	150	200	262	262	350	350					
		Torque	1091 lb in	1576 lb in	2600 lb in	3998 lb in	5428 lb in	8331 lb in					
		OHL	1140 lb	1745 lb	3326 lb	3326 lb	5731 lb	5731 lb					
5.80	300	SIZE	150	200	262	262	350	350					
		Torque	1362 lb in	1969 lb in	3248 lb in	4994 lb in	6782 lb in	10408 lb in					
		OHL	1136 lb	1767 lb	3353 lb	3353 lb	5976 lb	5976 lb					

* Refer to page G5-55 for exact ratio

FEATURES/BENEFITS PAGE G5-2	SPECIFICATION PAGE G5-4	NOMENCLATURE PAGE G5-5	MODIFICATION/ACCESSORIES PAGE G5-34
--------------------------------	----------------------------	---------------------------	--



Combination TIGEAR

1.25 REDUCER SERVICE FACTOR 1750 RPM INPUT

RPM OUT	NOM. RATIO*	MOTOR HORSEPOWER											
			0.25	0.33	0.50	0.75	1	1.50	2	3	5	7.50	10
156	10	SIZE	150	150	150	150	150	200	200	262	350	350	
		Torque	68 lb in	96 lb in	157 lb in	247 lb in	336 lb in	537 lb in	723 lb in	1106 lb in	1828 lb in	2767 lb in	
		OHL	896 lb	896 lb	896 lb	896 lb	896 lb	1306 lb	1306 lb	2220 lb	4653 lb	4653 lb	
125	15	SIZE	150	150	150	150	150	200	200	262	350	350	
		Torque	85 lb in	121 lb in	198 lb in	310 lb in	423 lb in	663 lb in	893 lb in	1358 lb in	2258 lb in	3417 lb in	
		OHL	910 lb	910 lb	910 lb	910 lb	910 lb	1325 lb	1325 lb	2283 lb	4726 lb	4726 lb	
105	18	SIZE	150	150	150	150	150	200	200	262	350	350	
		Torque	102 lb in	145 lb in	236 lb in	371 lb in	505 lb in	791 lb in	1066 lb in	1622 lb in	2696 lb in	4079 lb in	
		OHL	920 lb	920 lb	920 lb	920 lb	920 lb	1339 lb	1339 lb	2371 lb	4785 lb	4785 lb	
86	20	SIZE	150	150	150	150	150	200	200	262	350	350	
		Torque	124 lb in	176 lb in	288 lb in	451 lb in	614 lb in	963 lb in	1297 lb in	1973 lb in	3280 lb in	4963 lb in	
		OHL	930 lb	930 lb	930 lb	930 lb	930 lb	1352 lb	1352 lb	2436 lb	4800 lb	4800 lb	
69	25	SIZE	150	150	150	150	150	200	200	262	350	350	
		Torque	155 lb in	220 lb in	359 lb in	563 lb in	768 lb in	1203 lb in	1620 lb in	2465 lb in	4097 lb in	6201 lb in	
		OHL	938 lb	938 lb	938 lb	938 lb	938 lb	1361 lb	1361 lb	2491 lb	4717 lb	4717 lb	
58	30	SIZE	150	150	150	150	200	200	262	262	350		
		Torque	189 lb in	266 lb in	430 lb in	672 lb in	921 lb in	1411 lb in	1913 lb in	2902 lb in	4872 lb in		
		OHL	970 lb	970 lb	970 lb	970 lb	1410 lb	1410 lb	2751 lb	2751 lb	4925 lb		
46	38	SIZE	150	150	150	150	200	200	262	262	350		
		Torque	236 lb in	332 lb in	538 lb in	840 lb in	1151 lb in	1763 lb in	2390 lb in	3625 lb in	6087 lb in		
		OHL	979 lb	979 lb	979 lb	979 lb	1421 lb	1421 lb	2781 lb	2781 lb	4823 lb		
43	40	SIZE	150	150	150	150	200	200	262	262	350		
		Torque	246 lb in	346 lb in	560 lb in	875 lb in	1209 lb in	1849 lb in	2510 lb in	3804 lb in	6397 lb in		
		OHL	981 lb	981 lb	981 lb	981 lb	1423 lb	1423 lb	2786 lb	2786 lb	5197 lb		
35	50	SIZE	150	150	150	150	200	200	262	262	350		
		Torque	307 lb in	433 lb in	700 lb in	1093 lb in	1511 lb in	2310 lb in	3136 lb in	4753 lb in	7992 lb in		
		OHL	985 lb	985 lb	985 lb	985 lb	1425 lb	1425 lb	2805 lb	2805 lb	5154 lb		
29	60	SIZE	150	150	150	200	200	262	262	350			
		Torque	360 lb in	504 lb in	811 lb in	1287 lb in	1746 lb in	2712 lb in	3647 lb in	5504 lb in			
		OHL	1013 lb	1013 lb	1013 lb	1472 lb	1472 lb	2910 lb	2910 lb	5064 lb			

* Refer to page G5-55 for exact ratio

FEATURES/BENEFITS PAGE G5-2	SPECIFICATION PAGE G5-4	NOMENCLATURE PAGE G5-5	MODIFICATION/ACCESSORIES PAGE G5-34
--------------------------------	----------------------------	---------------------------	--

EASY SELECTION



Combination TIGEAR

1.25 REDUCER SERVICE FACTOR 1750 RPM INPUT

RPM OUT	NOM. RATIO*	MOTOR HORSEPOWER											
			0.25	0.33	0.50	0.75	1	1.50	2	3	5	7.50	10
23	75	SIZE	150	150	150	200	200	262	350	350			
		Torque	450 lb in	630 lb in	1012 lb in	1607 lb in	2181 lb in	3388 lb in	4505 lb in	6876 lb in			
		OHL	1020 lb	1020 lb	1020 lb	1470 lb	1470 lb	2933 lb	2933 lb	5501 lb			
22	80	SIZE	150	150	150	200	262	350	350	350			
		Torque	466 lb in	648 lb in	1034 lb in	1647 lb in	2230 lb in	3427 lb in	4642 lb in	7073 lb in			
		OHL	1023 lb	1023 lb	1023 lb	1537 lb	2932 lb	5542 lb	5542 lb	5542 lb			
19	90	SIZE	150	150	200	200	200	350	350	350			
		Torque	548 lb in	763 lb in	1198 lb in	1863 lb in	2529 lb in	3430 lb in	4646 lb in	7078 lb in			
		OHL	1063 lb	1063 lb	1542 lb	1542 lb	1542 lb	5481 lb	5481 lb	5481 lb			
17	100	SIZE	150	150	150	200	262	350	350	350			
		Torque	582 lb in	810 lb in	1292 lb in	2057 lb in	2663 lb in	4281 lb in	5800 lb in	8836 lb in			
		OHL	1070 lb	1070 lb	1070 lb	1544 lb	2937 lb	5462 lb	5462 lb	5462 lb			
14	125	SIZE	150	150	200	200	262	350	350				
		Torque	626 lb in	868 lb in	1608 lb in	2490 lb in	3240 lb in	5213 lb in	7062 lb in				
		OHL	1081 lb	1081 lb	1545 lb	1545 lb	3039 lb	5339 lb	5339 lb				
12	150	SIZE	150	150	200	262	262	350	350				
		Torque	783 lb in	1085 lb in	1804 lb in	2980 lb in	4037 lb in	6089 lb in	8248 lb in				
		OHL	1082 lb	1082 lb	1607 lb	3051 lb	3051 lb	5207 lb	5207 lb				
11	160	SIZE	150	150	200	262	262	350	350				
		Torque	796 lb in	1100 lb in	1823 lb in	2919 lb in	3946 lb in	6024 lb in	8146 lb in				
		OHL	1133 lb	1133 lb	1667 lb	3195 lb	3195 lb	5829 lb	5829 lb				
8.60	200	SIZE	150	150	200	262	262	350	350				
		Torque	995 lb in	1374 lb in	2277 lb in	3646 lb in	4930 lb in	7526 lb in	10177 lb in				
		OHL	1142 lb	1142 lb	1681 lb	3220 lb	3220 lb	5766 lb	5766 lb				
7.20	240	SIZE	200	200	262	350	350	350					
		Torque	1150 lb in	1576 lb in	2600 lb in	4058 lb in	5428 lb in	8331 lb in					
		OHL	1745 lb	1745 lb	3326 lb	3326 lb	5731 lb	5731 lb					
5.80	300	SIZE	200	200	262	350	350	350					
		Torque	1437 lb in	1969 lb in	3248 lb in	5070 lb in	6782 lb in	10408 lb in					
		OHL	1767 lb	1767 lb	3353 lb	3353 lb	5976 lb	5976 lb					

* Refer to page G5-55 for exact ratio

FEATURES/BENEFITS PAGE G5-2	SPECIFICATION PAGE G5-4	NOMENCLATURE PAGE G5-5	MODIFICATION/ACCESSORIES PAGE G5-34
--------------------------------	----------------------------	---------------------------	--



Combination TIGEAR

1.50 REDUCER SERVICE FACTOR 1750 RPM INPUT

RPM OUT	NOM. RATIO*	MOTOR HORSEPOWER												
			0.25	0.33	0.50	0.75	1	1.50	2	3	5	7.50	10	
156	10	SIZE	150	150	150	150	150	150	200	200	262	350		
		Torque	68 lb in	96 lb in	157 lb in	247 lb in	336 lb in	537 lb in	723 lb in	1106 lb in	1828 lb in			
		OHL	896 lb	896 lb	896 lb	896 lb	896 lb	1306 lb	1306 lb	2220 lb	4653 lb			
125	15	SIZE	150	150	150	150	150	150	200	200	262	350		
		Torque	85 lb in	121 lb in	198 lb in	310 lb in	423 lb in	663 lb in	893 lb in	1358 lb in	2258 lb in			
		OHL	910 lb	910 lb	910 lb	910 lb	910 lb	1325 lb	1325 lb	2283 lb	4726 lb			
105	18	SIZE	150	150	150	150	150	150	200	200	262	350		
		Torque	102 lb in	145 lb in	236 lb in	371 lb in	505 lb in	791 lb in	1066 lb in	1622 lb in	2696 lb in			
		OHL	920 lb	920 lb	920 lb	920 lb	920 lb	1339 lb	1339 lb	2371 lb	4785 lb			
86	20	SIZE	150	150	150	150	150	150	200	200	262	350		
		Torque	124 lb in	176 lb in	288 lb in	451 lb in	614 lb in	963 lb in	1297 lb in	1973 lb in	3280 lb in			
		OHL	930 lb	930 lb	930 lb	930 lb	930 lb	1352 lb	1352 lb	2436 lb	4800 lb			
69	25	SIZE	150	150	150	150	150	150	200	200	262	350		
		Torque	155 lb in	220 lb in	359 lb in	563 lb in	768 lb in	1203 lb in	1620 lb in	2465 lb in	4097 lb in			
		OHL	938 lb	938 lb	938 lb	938 lb	938 lb	1361 lb	1361 lb	2491 lb	4717 lb			
58	30	SIZE	150	150	150	150	200	262	262	262	350			
		Torque	189 lb in	266 lb in	430 lb in	672 lb in	921 lb in	1419 lb in	1913 lb in	2902 lb in	4872 lb in			
		OHL	970 lb	970 lb	970 lb	970 lb	1410 lb	2751 lb	2751 lb	2751 lb	4925 lb			
46	38	SIZE	150	150	150	150	200	262	262	262	350			
		Torque	236 lb in	332 lb in	538 lb in	840 lb in	1151 lb in	1773 lb in	2390 lb in	3625 lb in	6087 lb in			
		OHL	979 lb	979 lb	979 lb	979 lb	1421 lb	2781 lb	2781 lb	2781 lb	4823 lb			
43	40	SIZE	150	150	150	150	200	262	262	350				
		Torque	246 lb in	346 lb in	560 lb in	875 lb in	1209 lb in	1863 lb in	2510 lb in	3781 lb in				
		OHL	981 lb	981 lb	981 lb	981 lb	1423 lb	2786 lb	2786 lb	5197 lb				
35	50	SIZE	150	150	150	150	200	262	262	350				
		Torque	307 lb in	433 lb in	700 lb in	1093 lb in	1511 lb in	2328 lb in	3136 lb in	4724 lb in				
		OHL	985 lb	985 lb	985 lb	985 lb	1425 lb	2805 lb	2805 lb	5154 lb				
29	60	SIZE	150	150	150	200	200	262	350	350				
		Torque	360 lb in	504 lb in	811 lb in	1287 lb in	1746 lb in	2712 lb in	3606 lb in	5504 lb in				
		OHL	1013 lb	1013 lb	1013 lb	1472 lb	1472 lb	2910 lb	5064 lb	5064 lb				

* Refer to page G5-55 for exact ratio

FEATURES/BENEFITS PAGE G5-2	SPECIFICATION PAGE G5-4	NOMENCLATURE PAGE G5-5	MODIFICATION/ACCESSORIES PAGE G5-34
--------------------------------	----------------------------	---------------------------	--

EASY SELECTION



Combination TIGEAR

1.50 REDUCER SERVICE FACTOR 1750 RPM INPUT

RPM OUT	NOM. RATIO*	MOTOR HORSEPOWER											
			0.25	0.33	0.50	0.75	1	1.50	2	3	5	7.50	10
23	75	SIZE	150	150	150	200	200	262	350	350			
		Torque	450 lb in	630 lb in	1012 lb in	1607 lb in	2181 lb in	3388 lb in	4505 lb in	6876 lb in			
		OHL	1020 lb	1020 lb	1020 lb	1470 lb	1470 lb	2933 lb	5501 lb	5501 lb			
22	80	SIZE	150	150	150	200	262	350	350	350			
		Torque	466 lb in	648 lb in	1034 lb in	1647 lb in	2230 lb in	3427 lb in	4642 lb in	7073 lb in			
		OHL	1023 lb	1023 lb	1023 lb	1537 lb	2932 lb	5542 lb	5542 lb	5542 lb			
19	90	SIZE	150	150	200	200	262	350	350				
		Torque	548 lb in	763 lb in	1198 lb in	1863 lb in	2218 lb in	3430 lb in	5376 lb in				
		OHL	1063 lb	1063 lb	1542 lb	1542 lb	2937 lb	5481 lb	5481 lb				
17	100	SIZE	150	150	150	200	262	350	350				
		Torque	582 lb in	810 lb in	1292 lb in	2057 lb in	2663 lb in	4281 lb in	5800 lb in				
		OHL	1070 lb	1070 lb	1070 lb	1544 lb	2937 lb	5462 lb	5462 lb				
14	125	SIZE	150	150	200	262	262	350	350				
		Torque	626 lb in	868 lb in	1608 lb in	2392 lb in	3240 lb in	5213 lb in	7062 lb in				
		OHL	1081 lb	1081 lb	1545 lb	3039 lb	3039 lb	5339 lb	5339 lb				
12	150	SIZE	150	150	200	262	262	350	350				
		Torque	783 lb in	1085 lb in	1804 lb in	2980 lb in	4037 lb in	6089 lb in	8248 lb in				
		OHL	1082 lb	1082 lb	1607 lb	3051 lb	3051 lb	5207 lb	5207 lb				
11	160	SIZE	150	200	262	262	262	350					
		Torque	796 lb in	1149 lb in	1891 lb in	2919 lb in	3946 lb in	6024 lb in					
		OHL	1133 lb	1667 lb	3195 lb	3195 lb	3195 lb	5829 lb					
8.6	200	SIZE	150	200	262	262	350	350					
		Torque	995 lb in	1435 lb in	2362 lb in	3646 lb in	4876 lb in	7526 lb in					
		OHL	1142 lb	1681 lb	3220 lb	3220 lb	5766 lb	5766 lb					
7.2	240	SIZE	200	262	262	350	350						
		Torque	1150 lb in	1649 lb in	2600 lb in	3977 lb in	5428 lb in						
		OHL	1745 lb	3326 lb	3326 lb	5731 lb	5731 lb						
5.8	300	SIZE	200	262	262	350	350						
		Torque	1437 lb in	2061 lb in	3248 lb in	4968 lb in	6782 lb in						
		OHL	1767 lb	3353 lb	3353 lb	5976 lb	5976 lb						

* Refer to page G5-55 for exact ratio

FEATURES/BENEFITS PAGE G5-2	SPECIFICATION PAGE G5-4	NOMENCLATURE PAGE G5-5	MODIFICATION/ACCESSORIES PAGE G5-34
--------------------------------	----------------------------	---------------------------	--



Combination TIGEAR

SELECTION USING RATING TABLES

Because the efficiency of worm gear speed reducers varies from approximately 60 to 90%, it is important to consider the horsepower/torque conditions at both input and output in a given application. In a situation where motor horsepower is known (e.g., competitive interchange or when a

particular motor is available), selection can be done based on input ratings. Where a gearbox is being selected by a designer who knows driven equipment loads, the reducer is selected from the output torque capacity.

HORSEPOWER METHOD OF SELECTION

Step 1: Determine Service Factor by referring to the reducer service factor table. Read the appropriate service factor.

Step 2: To determine Equivalent Horsepower, multiply the motor horsepower by the service factor obtained in Step 1.

Step 3: To calculate the required Ratio, divide the motor shaft rpm by the reducer output shaft rpm.

Step 4: To determine the Unit Size, refer to the rating tables and read across from the ratio row and down from the motor rpm column to select a unit whose mechanical input horsepower rating meets or exceeds the equivalent horsepower.

Reducer Service Factors

Prime Mover	Duration of Service Per Day	Driven Machine Load Classification		
		Uniform	Medium Shock	Heavy Shock
Electric Motor	Occasional 1/2 hour	0.80	0.90	1.00
	Intermittent 2 hours	0.90	1.00	1.25
	10 hours	1.00	1.25	1.50
	24 hours	1.25	1.50	1.75
Electric Motor with frequent Starts and Stops	Occasional 1/2 hour	0.90	1.00	1.25
	Intermittent 2 hours	1.00	1.25	1.50
	10 hours	1.25	1.50	1.75
	24 hours	1.50	1.75	2.00

Overhung Load

To determine overhung load, divide the torque required by the pitch radius of the sprocket, sheave, etc. and multiply by the appropriate factor as follows:

Chain Drive	1.00
Synchronous Belt Drive	1.10
Spur or Helical Gear	1.25
V-Belt	1.50
Flat Belt	2.50

The calculated overhung load must not exceed the output overhung load rating.

For loads acting a more than one shaft diameter from the seal face, use the following conversion factors:

Distance in Shaft diameters from Output Seal Face	Multiply Overhung Load Capacity by this Factor
1D	1.00
2D	0.65
3D	0.45
4D	0.35
5D	0.30

SELECTION



Combination TIGEAR

TORQUE METHOD OF SERVICE

- Step 1: Determine Service Factor** Referring to the reducer service factor table (page G5-13), determine the appropriate service factor.
- Step 2: Determine Equivalent Torque** Multiply the torque required to drive the load at the output of the reducer by the service factor obtained in Step 1. (If drive components, e.g. chain or belt drives, are used between reducer and driven equipment be sure to account for them when calculating output torque at the reducer.)
- Step 3: Calculate Required Ratio** Divide the motor shaft rpm by the reducer output shaft rpm.
- Step 4: Determine Unit Size** Refer to the rating tables and read across from ratio row and down from motor rpm column to select a unit whose mechanical output torque rating meets or exceeds the equivalent torque.
- Step 5: Determine Required Motor Horsepower** First, calculate the output horsepower using the following equation, where output torque is the torque required to drive the load at the output of the reducer:

$$\text{Output Hp} = \frac{\text{Output Speed} \times \text{Output Torque}}{63025}$$

Then calculate the required motor horsepower using the following equation to account for reducer efficiency:

$$\text{Required motor Horsepower} = \frac{\text{Output Hp} \times \text{Rated Input Hp}}{\text{Rated Output Hp}}$$

- Step 6: Select Motor Hp** From available motors, select a horsepower that is equal to or greater than the value from Step 5: When the nearest motor horsepower is greater, check service factor at input by dividing rated input horsepower by actual motor horsepower. If the service factor is less than the value from Step 1, a larger reducer may be required.

FEATURES/BENEFITS PAGE G5-2	SPECIFICATION PAGE G5-4	NOMENCLATURE PAGE G5-5	MODIFICATION/ACCESSORIES PAGE G5-34
--------------------------------	----------------------------	---------------------------	--



Combination TIGEAR Size C150

RATIO	RATING DATA	INPUT RPM					PART NUMBERS		SHAFT POSITION
		2500	1750	1450	1170	870	56C	140TC	
7.50	Output RPM	341	239	198	160	119	056C150T007S1A	140C150T007S1A	Taper Hollow
	Mechanical Input HP	1.99	1.52	1.32	1.12	0.85	056C150S007S1A	140C150S007S1A	Str. Hollow
	Output Torque (lb. in.)	318	345	358	375	376	056C150B007K1A	140C150B007K1A	K1
	Output HP Rating	1.72	1.31	1.12	0.95	0.71	056C150B007L1A	140C150B007L1A	L1
	Output OHL (lbs.)	843	866	877	889	903	056C150B007LKA	140C150B007LKA	LK
9.40	Output RPM	271	190	157	127	94	056C150T009S1A	140C150T009S1A	Taper Hollow
	Mechanical Input HP	1.99	1.52	1.32	1.12	0.85	056C150S009S1A	140C150S009S1A	Str. Hollow
	Output Torque (lb. in.)	400	434	451	472	473	056C150B009K1A	140C150B009K1A	K1
	Output HP Rating	1.72	1.31	1.12	0.95	0.71	056C150B009L1A	140C150B009L1A	L1
	Output OHL (lbs.)	854	882	898	916	942	056C150B009LKA	140C150B009LKA	LK
10	Output RPM	225.50	157.80	130.80	105.10	78.47	056C150T010S1A	140C150T010S1A	Taper Hollow
	Mechanical Input HP	2.01	1.52	1.32	1.12	0.85	056C150S010S1A	140C150S010S1A	Str. Hollow
	Output Torque (lb. in.)	487	522	542	567	568	056C150B010K1A	140C150B010K1A	K1
	Output HP Rating	1.74	1.31	1.12	0.95	0.71	056C150B010L1A	140C150B010L1A	L1
	Output OHL (lbs.)	867	896	919	933	960	056C150B010LKA	140C150B010LKA	LK
15	Output RPM	179.10	125.40	103.90	83.82	62.33	056C150T015S1A	140C150T015S1A	Taper Hollow
	Mechanical Input HP	2.01	1.52	1.32	1.12	0.85	056C150S015S1A	140C150S015S1A	Str. Hollow
	Output Torque (lb. in.)	613	657	682	714	716	056C150B015K1A	140C150B015K1A	K1
	Output HP Rating	1.74	1.31	1.12	0.95	0.71	056C150B015L1A	140C150B015L1A	L1
	Output OHL (lbs.)	881	910	935	948	976	056C150B015LKA	140C150B015LKA	LK
18	Output RPM	150.00	105.00	87.00	70.20	52.20	056C150T018S1A	140C150T018S1A	Taper Hollow
	Mechanical Input HP	2.01	1.52	1.32	1.12	0.85	056C150S018S1A	140C150S018S1A	Str. Hollow
	Output Torque (lb. in.)	732	784	815	852	854	056C150B018K1A	140C150B018K1A	K1
	Output HP Rating	1.74	1.31	1.12	0.95	0.71	056C150B018L1A	140C150B018L1A	L1
	Output OHL (lbs.)	891	920	947	959	987	056C150B018LKA	140C150B018LKA	LK
20	Output RPM	123.30	86.30	71.51	57.70	42.90	056C150T020S1A	140C150T020S1A	Taper Hollow
	Mechanical Input HP	2.01	1.52	1.32	1.12	0.85	056C150S020S1A	140C150S020S1A	Str. Hollow
	Output Torque (lb. in.)	891	954	991	1037	1040	056C150B020K1A	140C150B020K1A	K1
	Output HP Rating	1.74	1.31	1.12	0.95	0.71	056C150B020L1A	140C150B020L1A	L1
	Output OHL (lbs.)	901	930	959	969	998	056C150B020LKA	140C150B020LKA	LK
25	Output RPM	98.68	69.08	57.24	46.18	34.34	056C150T025S1A	140C150T025S1A	Taper Hollow
	Mechanical Input HP	2.01	1.52	1.32	1.12	0.85	056C150S025S1A	140C150S025S1A	Str. Hollow
	Output Torque (lb. in.)	1113	1192	1238	1296	1299	056C150B025K1A	140C150B025K1A	K1
	Output HP Rating	1.74	1.31	1.12	0.95	0.71	056C150B025L1A	140C150B025L1A	L1
	Output OHL (lbs.)	909	938	971	978	1008	056C150B025LKA	140C150B025LKA	LK
30	Output RPM	82.19	57.53	47.67	38.47	28.60	056C150T030S1A	140C150T030S1A	Taper Hollow
	Mechanical Input HP	1.69	1.11	1.01	0.87	0.75	056C150S030S1A	140C150S030S1A	Str. Hollow
	Output Torque (lb. in.)	1106	1022	1113	1184	1361	056C150B030K1A	140C150B030K1A	K1
	Output HP Rating	1.44	0.93	0.84	0.72	0.62	056C150B030L1A	140C150B030L1A	L1
	Output OHL (lbs.)	932	970	977	1003	1041	056C150B030LKA	140C150B030LKA	LK
38	Output RPM	65.79	46.05	38.16	30.79	22.89	056C150T038S1A	140C150T038S1A	Taper Hollow
	Mechanical Input HP	1.69	1.11	1.01	0.87	0.75	056C150S038S1A	140C150S038S1A	Str. Hollow
	Output Torque (lb. in.)	1382	1277	1391	1479	1700	056C150B038K1A	140C150B038K1A	K1
	Output HP Rating	1.44	0.93	0.84	0.72	0.62	056C150B038L1A	140C150B038L1A	L1
	Output OHL (lbs.)	940	979	983	1012	1052	056C150B038LKA	140C150B038LKA	LK
40	Output RPM	61.64	43.15	35.75	28.85	21.45	056C150T040S1A	140C150T040S1A	Taper Hollow
	Mechanical Input HP	1.50	1.13	1.01	0.83	0.66	056C150S040S1A	140C150S040S1A	Str. Hollow
	Output Torque (lb. in.)	1277	1347	1452	1458	1548	056C150B040K1A	140C150B040K1A	K1
	Output HP Rating	1.25	0.92	0.82	0.67	0.53	056C150B040L1A	140C150B040L1A	L1
	Output OHL (lbs.)	940	981	983	1013	1054	056C150B040LKA	140C150B040LKA	LK
50	Output RPM	49.34	34.54	28.62	23.09	17.17	056C150T050S1A	140C150T050S1A	Taper Hollow
	Mechanical Input HP	1.50	1.11	1.01	0.81	0.62	056C150S050S1A	140C150S050S1A	Str. Hollow
	Output Torque (lb. in.)	1596	1663	1814	1776	1802	056C150B050K1A	140C150B050K1A	K1
	Output HP Rating	1.25	0.91	0.82	0.65	0.49	056C150B050L1A	140C150B050L1A	L1
	Output OHL (lbs.)	943	985	983	1016	1061	056C150B050LKA	140C150B050LKA	LK

NOTE: All units include drilled and tapped mounting holes on the top and bottom surfaces. If optional bolt-on foot is required, order part number 6011246.

FEATURES/BENEFITS PAGE G5-2	SPECIFICATION PAGE G5-4	NOMENCLATURE PAGE G5-5	MODIFICATION/ACCESSORIES PAGE G5-34
--------------------------------	----------------------------	---------------------------	--

SELECTION



Combination TIGEAR Size C150

RATIO	RATING DATA	INPUT RPM					PART NUMBER		SHAFT POSITION
		2500	1750	1450	1170	870	56C	140TC	
60	Output RPM	41.10	28.77	23.84	19.23	14.30	056C150T060S1A	---	Taper Hollow
	Mechanical Input HP	1.08	0.87	0.77	0.64	0.50	056C150S060S1A	---	Str. Hollow
	Output Torque (lb. in.)	1299	1474	1556	1585	1658	056C150B060K1A	---	K1
	Output HP Rating	0.85	0.67	0.59	0.48	0.38	056C150B060L1A	---	L1
	Output OHL (lbs.)	985	1013	1019	1062	1063	056C150B060LKA	---	LK
75	Output RPM	32.89	23.03	19.08	15.39	11.45	056C150T075S1A	---	Taper Hollow
	Mechanical Input HP	1.08	0.80	0.75	0.59	0.45	056C150S075S1A	---	Str. Hollow
	Output Torque (lb. in.)	1623	1690	1898	1809	1834	056C150B075K1A	---	K1
	Output HP Rating	0.85	0.62	0.57	0.44	0.33	056C150B075L1A	---	L1
	Output OHL (lbs.)	990	1020	1064	1067	1113	056C150B075LKA	---	LK
80	Output RPM	30.82	21.58	17.88	14.42	10.73	056C150T080S1A	---	Taper Hollow
	Mechanical Input HP	0.85	0.75	0.64	0.53	0.42	056C150S080S1A	---	Str. Hollow
	Output Torque (lb. in.)	1293	1603	1619	1649	1699	056C150B080K1A	---	K1
	Output HP Rating	0.63	0.55	0.46	0.38	0.29	056C150B080L1A	---	L1
	Output OHL (lbs.)	1019	1023	1068	1070	1118	056C150B080LKA	---	LK
90	Output RPM	27.41	19.19	15.90	12.83	9.54	056C150T090S1A	---	Taper Hollow
	Mechanical Input HP	0.75	0.57	0.50	0.41	0.31	056C150S090S1A	---	Str. Hollow
	Output Torque (lb. in.)	1315	1416	1480	1475	1506	056C150B090K1A	---	K1
	Output HP Rating	0.57	0.43	0.37	0.30	0.23	056C150B090L1A	---	L1
	Output OHL (lbs.)	1020	1063	1068	1111	1115	056C150B090LKA	---	LK
100	Output RPM	24.67	17.27	14.31	11.55	8.59	056C150T100S1A	---	Taper Hollow
	Mechanical Input HP	0.85	0.65	0.57	0.50	0.36	056C150S100S1A	---	Str. Hollow
	Output Torque (lb. in.)	1616	1717	1813	1928	1849	056C150B100K1A	---	K1
	Output HP Rating	0.63	0.47	0.41	0.35	0.25	056C150B100L1A	---	L1
	Output OHL (lbs.)	1025	1070	1073	1069	1122	056C150B100LKA	---	LK
125	Output RPM	20.55	14.38	11.92	9.62	7.15	056C150T125S1A	---	Taper Hollow
	Mechanical Input HP	0.63	0.52	0.47	0.40	0.33	056C150S125S1A	---	Str. Hollow
	Output Torque (lb. in.)	1251	1453	1556	1616	1736	056C150B125K1A	---	K1
	Output HP Rating	0.41	0.33	0.29	0.25	0.20	056C150B125L1A	---	L1
	Output OHL (lbs.)	1071	1081	1125	1132	1134	056C150B125LKA	---	LK
150	Output RPM	16.45	11.51	9.54	7.70	5.72	056C150T150S1A	---	Taper Hollow
	Mechanical Input HP	0.63	0.50	0.44	0.37	0.29	056C150S150S1A	---	Str. Hollow
	Output Torque (lb. in.)	1562	1717	1813	1846	1857	056C150B150K1A	---	K1
	Output HP Rating	0.41	0.31	0.27	0.23	0.17	056C150B150L1A	---	L1
	Output OHL (lbs.)	1081	1082	1135	1136	1173	056C150B150LKA	---	LK
160	Output RPM	15.41	10.79	8.94	7.21	5.36	056C150T160S1A	---	Taper Hollow
	Mechanical Input HP	0.52	0.47	0.39	0.33	0.25	056C150S160S1A	---	Str. Hollow
	Output Torque (lb. in.)	1300	1631	1618	1643	1592	056C150B160K1A	---	K1
	Output HP Rating	0.32	0.28	0.23	0.19	0.14	056C150B160L1A	---	L1
	Output OHL (lbs.)	1084	1133	1139	1141	1178	056C150B160LKA	---	LK
200	Output RPM	12.34	8.63	7.15	5.77	4.29	056C150T200S1A	---	Taper Hollow
	Mechanical Input HP	0.52	0.42	0.36	0.30	0.23	056C150S200S1A	---	Str. Hollow
	Output Torque (lb. in.)	1624	1788	1857	1857	1857	056C150B200K1A	---	K1
	Output HP Rating	0.32	0.25	0.21	0.17	0.13	056C150B200L1A	---	L1
	Output OHL (lbs.)	1090	1142	1143	1179	1231	056C150B200LKA	---	LK
240	Output RPM	10.27	7.19	5.96	4.81	3.58	056C150T240S1A	---	Taper Hollow
	Mechanical Input HP	0.30	0.25	0.22	0.19	0.16	056C150S240S1A	---	Str. Hollow
	Output Torque (lb. in.)	926	1091	1140	1208	1288	056C150B240K1A	---	K1
	Output HP Rating	0.15	0.12	0.11	0.09	0.07	056C150B240L1A	---	L1
	Output OHL (lbs.)	1160	1140	1134	1232	1251	056C150B240LKA	---	LK
300	Output RPM	8.22	5.76	4.77	3.85	2.86	056C150T300S1A	---	Taper Hollow
	Mechanical Input HP	0.30	0.25	0.22	0.19	0.16	056C150S300S1A	---	Str. Hollow
	Output Torque (lb. in.)	1157	1362	1425	1509	1609	056C150B300K1A	---	K1
	Output HP Rating	0.15	0.12	0.11	0.09	0.07	056C150B300L1A	---	K1
	Output OHL (lbs.)	1176	1136	1120	1244	1258	056C150B300LKA	---	LK

NOTE: All units include drilled and tapped mounting holes on the top and bottom surfaces. If optional bolt-on foot is required, order part number 6011246.

FEATURES/BENEFITS PAGE G5-2	SPECIFICATION PAGE G5-4	NOMENCLATURE PAGE G5-5	MODIFICATION/ACCESSORIES PAGE G5-34
--------------------------------	----------------------------	---------------------------	--



Combination TIGEAR Size C200

RATIO	RATING DATA	INPUT RPM					PART NUMBERS			SHAFT POSITION
		2500	1750	1450	1170	870	56C	140TC	180TC	
9.40	Output RPM	265	185	154	124	92	056C200T009S1A	140C200T009S1A	180C200T009S1A	Taper Hollow
	Mechanical Input HP	4.35	3.58	3.20	2.64	1.97	056C200S009S1A	140C200S009S1A	180C200S009S1A	Str. Hollow
	Output Torque (lb. in.)	936	1093	1175	1189	1181	056C200B009K1A	140C200B009K1A	180C200B009K1A	K1
	Output HP Rating	3.94	3.22	2.87	2.34	1.73	056C200B009L1A	140C200B009L1A	180C200B009L1A	L1
	Output OHL (lbs.)	1495	1473	1455	1425	1361	056C200B009LKA	140C200B009LKA	180C200B009LKA	LK
10	Output RPM	221.20	154.80	128.30	103.50	76.96	056C200T010S1A	140C200T010S1A	180C200T010S1A	Taper Hollow
	Mechanical Input HP	4.35	3.58	3.20	2.64	2.00	056C200S010S1A	140C200S010S1A	180C200S010S1A	Str. Hollow
	Output Torque (lb. in.)	1123	1312	1409	1426	1442	056C200B010K1A	140C200B010K1A	180C200B010K1A	K1
	Output HP Rating	3.94	3.22	2.87	2.34	1.76	056C200B010L1A	140C200B010L1A	180C200B010L1A	L1
	Output OHL (lbs.)	1255	1306	1320	1359	1383	056C200B010LKA	140C200B010LKA	180C200B010LKA	LK
15	Output RPM	179.10	125.40	103.90	83.82	62.33	056C200T015S1A	140C200T015S1A	180C200T015S1A	Taper Hollow
	Mechanical Input HP	4.35	3.58	3.20	2.64	2.00	056C200S015S1A	140C200S015S1A	180C200S015S1A	Str. Hollow
	Output Torque (lb. in.)	1386	1620	1740	1761	1780	056C200B015K1A	140C200B015K1A	180C200B015K1A	K1
	Output HP Rating	3.94	3.22	2.87	2.34	1.76	056C200B015L1A	140C200B015L1A	180C200B015L1A	L1
	Output OHL (lbs.)	1295	1325	1337	1379	1400	056C200B015LKA	140C200B015LKA	180C200B015LKA	LK
18	Output RPM	150.00	105.00	87.00	70.20	52.20	056C200T018S1A	140C200T018S1A	180C200T018S1A	Taper Hollow
	Mechanical Input HP	4.35	3.58	3.20	2.64	2.00	056C200S018S1A	140C200S018S1A	180C200S018S1A	Str. Hollow
	Output Torque (lb. in.)	1655	1934	2078	2103	2126	056C200B018K1A	140C200B018K1A	180C200B018K1A	K1
	Output HP Rating	3.94	3.22	2.87	2.34	1.76	056C200B018L1A	140C200B018L1A	180C200B018L1A	L1
	Output OHL (lbs.)	1312	1339	1349	1394	1410	056C200B018LKA	140C200B018LKA	180C200B018LKA	LK
20	Output RPM	123.30	86.30	71.51	57.70	42.90	056C200T020S1A	140C200T020S1A	180C200T020S1A	Taper Hollow
	Mechanical Input HP	4.35	3.58	3.20	2.64	2.00	056C200S020S1A	140C200S020S1A	180C200S020S1A	Str. Hollow
	Output Torque (lb. in.)	2014	2353	2528	2558	2586	056C200B020K1A	140C200B020K1A	180C200B020K1A	K1
	Output HP Rating	3.94	3.22	2.87	2.34	1.76	056C200B020L1A	140C200B020L1A	180C200B020L1A	L1
	Output OHL (lbs.)	1329	1352	1358	1408	1418	056C200B020LKA	140C200B020LKA	180C200B020LKA	LK
25	Output RPM	98.68	69.08	57.24	46.18	34.34	056C200T025S1A	140C200T025S1A	180C200T025S1A	Taper Hollow
	Mechanical Input HP	4.35	3.58	3.14	2.61	2.00	056C200S025S1A	140C200S025S1A	180C200S025S1A	Str. Hollow
	Output Torque (lb. in.)	2516	2940	3097	3170	3231	056C200B025K1A	140C200B025K1A	180C200B025K1A	K1
	Output HP Rating	3.94	3.22	2.81	2.32	1.76	056C200B025L1A	140C200B025L1A	180C200B025L1A	L1
	Output OHL (lbs.)	1346	1361	1361	1419	1418	056C200B025LKA	140C200B025LKA	180C200B025LKA	LK
30	Output RPM	82.19	57.53	47.67	38.47	28.60	056C200T030S1A	140C200T030S1A	---	Taper Hollow
	Mechanical Input HP	2.95	2.06	1.89	1.69	1.41	056C200S030S1A	140C200S030S1A	---	Str. Hollow
	Output Torque (lb. in.)	1989	1960	2157	2374	2634	056C200B030K1A	140C200B030K1A	---	K1
	Output HP Rating	2.59	1.79	1.63	1.45	1.20	056C200B030L1A	140C200B030L1A	---	L1
	Output OHL (lbs.)	1385	1410	1445	1457	1513	056C200B030LKA	140C200B030LKA	---	LK
38	Output RPM	65.79	46.05	38.16	30.79	22.89	056C200T038S1A	140C200T038S1A	---	Taper Hollow
	Mechanical Input HP	2.95	2.06	1.89	1.69	1.41	056C200S038S1A	140C200S038S1A	---	Str. Hollow
	Output Torque (lb. in.)	2484	2449	2695	2966	3291	056C200B038K1A	140C200B038K1A	---	K1
	Output HP Rating	2.59	1.79	1.63	1.45	1.20	056C200B038L1A	140C200B038L1A	---	L1
	Output OHL (lbs.)	1403	1421	1460	1467	1526	056C200B038LKA	140C200B038LKA	---	LK
40	Output RPM	61.64	43.15	35.75	28.85	21.45	056C200T040S1A	140C200T040S1A	---	Taper Hollow
	Mechanical Input HP	2.53	2.08	1.88	1.54	1.17	056C200S040S1A	140C200S040S1A	---	Str. Hollow
	Output Torque (lb. in.)	2226	2585	2798	2826	2826	056C200B040K1A	140C200B040K1A	---	K1
	Output HP Rating	2.18	1.77	1.59	1.29	0.96	056C200B040L1A	140C200B040L1A	---	L1
	Output OHL (lbs.)	1407	1423	1462	1467	1529	056C200B040LKA	140C200B040LKA	---	LK
50	Output RPM	49.34	34.54	28.62	23.09	17.17	056C200T050S1A	140C200T050S1A	---	Taper Hollow
	Mechanical Input HP	2.53	2.03	1.76	1.50	1.12	056C200S050S1A	140C200S050S1A	---	Str. Hollow
	Output Torque (lb. in.)	2782	3165	3280	3429	3381	056C200B050K1A	140C200B050K1A	---	K1
	Output HP Rating	2.18	1.73	1.49	1.26	0.92	056C200B050L1A	140C200B050L1A	---	L1
	Output OHL (lbs.)	1421	1425	1469	1465	1533	056C200B050LKA	140C200B050LKA	---	LK
60	Output RPM	41.10	28.77	23.84	19.23	14.30	056C200T060S1A	140C200T060S1A	---	Taper Hollow
	Mechanical Input HP	1.81	1.50	1.33	1.09	0.83	056C200S060S1A	140C200S060S1A	---	Str. Hollow
	Output Torque (lb. in.)	2278	2665	2826	2826	2826	056C200B060K1A	140C200B060K1A	---	K1
	Output HP Rating	1.49	1.22	1.07	0.86	0.64	056C200B060L1A	140C200B060L1A	---	L1
	Output OHL (lbs.)	1458	1472	1529	1537	1585	056C200B060LKA	140C200B060LKA	---	LK

NOTE: All units include drilled and tapped mounting holes on the top and bottom surfaces. If optional bolt-on foot is required, order part number 6011253.

FEATURES/BENEFITS PAGE G5-2	SPECIFICATION PAGE G5-4	NOMENCLATURE PAGE G5-5	MODIFICATION/ACCESSORIES PAGE G5-34
--------------------------------	----------------------------	---------------------------	--

SELECTION



Combination TIGEAR Size C200

RATIO	RATING DATA	INPUT RPM					PART NUMBERS			SHAFT POSITION
		2500	1750	1450	1170	870	56C	140TC	180TC	
75	Output RPM	32.89	23.03	19.08	15.39	11.45	056C200T075S1A	140C200T075S1A	---	Taper Hollow
	Mechanical Input HP	1.81	1.50	1.27	1.05	0.81	056C200S075S1A	140C200S075S1A	---	Str. Hollow
	Output Torque (lb. in.)	2846	3329	3367	3390	3453	056C200B075K1A	140C200B075K1A	---	K1
	Output HP Rating	1.49	1.22	1.02	0.83	0.63	056C200B075L1A	140C200B075L1A	---	L1
	Output OHL (lbs.)	1510	1470	1539	1538	1587	056C200B075LKA	140C200B075LKA	---	LK
80	Output RPM	30.82	21.58	17.88	14.42	10.73	056C200T080S1A	140C200T080S1A	---	Taper Hollow
	Mechanical Input HP	1.48	1.18	1.06	0.87	0.66	056C200S080S1A	140C200S080S1A	---	Str. Hollow
	Output Torque (lb. in.)	2325	2640	2826	2826	2826	056C200B080K1A	140C200B080K1A	---	K1
	Output HP Rating	1.14	0.90	0.80	0.65	0.48	056C200B080L1A	140C200B080L1A	---	L1
	Output OHL (lbs.)	1516	1537	1544	1590	1653	056C200B080LKA	140C200B080LKA	---	LK
90	Output RPM	27.41	19.19	15.90	12.83	9.54	056C200T090S1A	140C200T090S1A	---	Taper Hollow
	Mechanical Input HP	1.53	1.27	1.11	0.92	0.75	056C200S090S1A	140C200S090S1A	---	Str. Hollow
	Output Torque (lb. in.)	2794	3248	3384	3418	3666	056C200B090K1A	140C200B090K1A	---	K1
	Output HP Rating	1.22	0.99	0.85	0.70	0.55	056C200B090L1A	140C200B090L1A	---	L1
	Output OHL (lbs.)	1478	1542	1544	1594	1660	056C200B090LKA	140C200B090LKA	---	LK
100	Output RPM	24.67	17.27	14.31	11.55	8.59	056C200T100S1A	140C200T100S1A	---	Taper Hollow
	Mechanical Input HP	1.48	1.17	1.02	0.85	0.65	056C200S100S1A	140C200S100S1A	---	Str. Hollow
	Output Torque (lb. in.)	2969	3290	3401	3434	3468	056C200B100K1A	140C200B100K1A	---	K1
	Output HP Rating	1.16	0.90	0.77	0.63	0.47	056C200B100L1A	140C200B100L1A	---	L1
	Output OHL (lbs.)	1532	1544	1543	1595	1665	056C200B100LKA	140C200B100LKA	---	LK
125	Output RPM	19.74	13.82	11.45	9.24	6.87	056C200T125S1A	---	---	Taper Hollow
	Mechanical Input HP	1.20	1.00	0.86	0.75	0.55	056C200S125S1A	---	---	Str. Hollow
	Output Torque (lb. in.)	2896	3372	3432	3660	3498	056C200B125K1A	---	---	K1
	Output HP Rating	0.91	0.74	0.62	0.54	0.38	056C200B125L1A	---	---	L1
	Output OHL (lbs.)	1546	1545	1599	1666	1672	056C200B125LKA	---	---	LK
150	Output RPM	16.45	11.51	9.54	7.70	5.72	056C200T150S1A	---	---	Taper Hollow
	Mechanical Input HP	1.02	0.85	0.78	0.65	0.51	056C200S150S1A	---	---	Str. Hollow
	Output Torque (lb. in.)	2735	3198	3440	3482	3518	056C200B150K1A	---	---	K1
	Output HP Rating	0.71	0.58	0.52	0.43	0.32	056C200B150L1A	---	---	L1
	Output OHL (lbs.)	1558	1607	1616	1683	1683	056C200B150LKA	---	---	LK
160	Output RPM	15.41	10.79	8.94	7.21	5.36	056C200T160S1A	---	---	Taper Hollow
	Mechanical Input HP	0.82	0.75	0.64	0.53	0.41	056C200S160S1A	---	---	Str. Hollow
	Output Torque (lb. in.)	2211	2813	2826	2826	2826	056C200B160K1A	---	---	K1
	Output HP Rating	0.54	0.48	0.40	0.32	0.24	056C200B160L1A	---	---	L1
	Output OHL (lbs.)	1600	1667	1684	1690	1763	056C200B160LKA	---	---	LK
200	Output RPM	12.34	8.63	7.15	5.77	4.29	056C200T200S1A	---	---	Taper Hollow
	Mechanical Input HP	0.82	0.75	0.63	0.53	0.41	056C200S200S1A	---	---	Str. Hollow
	Output Torque (lb. in.)	2762	3514	3496	3520	3530	056C200B200K1A	---	---	K1
	Output HP Rating	0.54	0.48	0.40	0.32	0.24	056C200B200L1A	---	---	L1
	Output OHL (lbs.)	1613	1681	1703	1691	1774	056C200B200LKA	---	---	LK
240	Output RPM	10.27	7.19	5.96	4.81	3.58	056C200T240S1A	---	---	Taper Hollow
	Mechanical Input HP	0.58	0.45	0.42	0.37	0.31	056C200S240S1A	---	---	Str. Hollow
	Output Torque (lb. in.)	2100	2236	2450	2628	2826	056C200B240K1A	---	---	K1
	Output HP Rating	0.34	0.26	0.23	0.20	0.16	056C200B240L1A	---	---	L1
	Output OHL (lbs.)	1676	1745	1764	1780	1836	056C200B240LKA	---	---	LK
300	Output RPM	8.22	5.76	4.77	3.85	2.86	056C200T300S1A	---	---	Taper Hollow
	Mechanical Input HP	0.58	0.45	0.42	0.37	0.31	056C200S300S1A	---	---	Str. Hollow
	Output Torque (lb. in.)	2624	2794	3061	3284	3530	056C200B300K1A	---	---	K1
	Output HP Rating	0.34	0.26	0.23	0.20	0.16	056C200B300L1A	---	---	L1
	Output OHL (lbs.)	1694	1767	1781	1789	1848	056C200B300LKA	---	---	LK

NOTE: All units include drilled and tapped mounting holes on the top and bottom surfaces. If optional bolt-on foot is required, order part number 6011253.

FEATURES/BENEFITS PAGE G5-2	SPECIFICATION PAGE G5-4	NOMENCLATURE PAGE G5-5	MODIFICATION/ACCESSORIES PAGE G5-34
--------------------------------	----------------------------	---------------------------	--



Combination TIGEAR Size C262

RATIO	RATING DATA	INPUT RPM					PART NUMBERS			SHAFT POSITION
		2500	1750	1450	1170	870	56C	140TC	180TC	
7.50	Output RPM	341	239	198	160	119	056C262T007S1A	140C262T007S1A	180C262T007S1A	Taper Hollow
	Mechanical Input HP	5.87	5.00	4.59	4.22	3.66	056C262S007S1A	140C262S007S1A	180C262S007S1A	Str. Hollow
	Output Torque (lb. in.)	993	1176	1317	1491	1722	056C262B007K1A	140C262B007K1A	180C262B007K1A	K1
	Output HP Rating	5.37	4.46	4.14	3.78	3.25	056C262B007L1A	140C262B007L1A	180C262B007L1A	L1
	Output OHL (lbs.)	2989	2969	2952	2930	2899	056C262B007LKA	140C262B007LKA	180C262B007LKA	LK
9.40	Output RPM	266	186	154	124	92	056C262T009S1A	140C262T009S1A	180C262T009S1A	Taper Hollow
	Mechanical Input HP	5.87	5.00	4.59	4.22	3.66	056C262S009S1A	140C262S009S1A	180C262S009S1A	Str. Hollow
	Output Torque (lb. in.)	1273	1511	1693	1924	2227	056C262B009K1A	140C262B009K1A	180C262B009K1A	K1
	Output HP Rating	5.37	4.46	4.14	3.78	3.25	056C262B009L1A	140C262B009L1A	180C262B009L1A	L1
	Output OHL (lbs.)	2375	2448	2485	2528	2589	056C262B009LKA	140C262B009LKA	180C262B009LKA	LK
10	Output RPM	220.00	154.00	127.60	103.00	76.56	056C262T010S1A	140C262T010S1A	180C262T010S1A	Taper Hollow
	Mechanical Input HP	6.52	5.43	5.07	4.65	4.03	056C262S010S1A	140C262S010S1A	180C262S010S1A	Str. Hollow
	Output Torque (lb. in.)	1710	2023	2257	2553	2946	056C262B010K1A	140C262B010K1A	180C262B010K1A	K1
	Output HP Rating	5.97	4.94	4.57	4.17	3.58	056C262B010L1A	140C262B010L1A	180C262B010L1A	L1
	Output OHL (lbs.)	2102	2220	2275	2637	2696	056C262B010LKA	140C262B010LKA	180C262B010LKA	LK
15	Output RPM	179.10	125.40	103.90	83.82	62.33	056C262T015S1A	140C262T015S1A	180C262T015S1A	Taper Hollow
	Mechanical Input HP	6.52	5.43	5.07	4.65	4.03	056C262S015S1A	140C262S015S1A	180C262S015S1A	Str. Hollow
	Output Torque (lb. in.)	2101	2485	2773	3135	3619	056C262B015K1A	140C262B015K1A	180C262B015K1A	K1
	Output HP Rating	5.97	4.94	4.57	4.17	3.58	056C262B015L1A	140C262B015L1A	180C262B015L1A	L1
	Output OHL (lbs.)	2181	2283	2326	2683	2727	056C262B015LKA	140C262B015LKA	180C262B015LKA	LK
18	Output RPM	150.00	105.00	87.00	70.20	52.20	056C262T018S1A	140C262T018S1A	180C262T018S1A	Taper Hollow
	Mechanical Input HP	6.52	5.43	5.07	4.65	4.03	056C262S018S1A	140C262S018S1A	180C262S018S1A	Str. Hollow
	Output Torque (lb. in.)	2509	2967	3311	3744	4321	056C262B018K1A	140C262B018K1A	180C262B018K1A	K1
	Output HP Rating	5.97	4.94	4.57	4.17	3.58	056C262B018L1A	140C262B018L1A	180C262B018L1A	L1
	Output OHL (lbs.)	2274	2371	2410	2717	2757	056C262B018LKA	140C262B018LKA	180C262B018LKA	LK
20	Output RPM	123.30	86.30	71.51	57.70	42.90	056C262T020S1A	140C262T020S1A	180C262T020S1A	Taper Hollow
	Mechanical Input HP	6.52	5.43	5.07	4.65	4.03	056C262S020S1A	140C262S020S1A	180C262S020S1A	Str. Hollow
	Output Torque (lb. in.)	3052	3610	4028	4555	5257	056C262B020K1A	140C262B020K1A	180C262B020K1A	K1
	Output HP Rating	5.97	4.94	4.57	4.17	3.58	056C262B020L1A	140C262B020L1A	180C262B020L1A	L1
	Output OHL (lbs.)	2357	2436	2461	2749	2781	056C262B020LKA	140C262B020LKA	180C262B020LKA	LK
25	Output RPM	98.68	69.08	57.24	46.18	34.34	056C262T025S1A	140C262T025S1A	180C262T025S1A	Taper Hollow
	Mechanical Input HP	6.52	5.37	5.07	4.62	3.60	056C262S025S1A	140C262S025S1A	180C262S025S1A	Str. Hollow
	Output Torque (lb. in.)	3813	4462	5032	5657	5863	056C262B025K1A	140C262B025K1A	180C262B025K1A	K1
	Output HP Rating	5.97	4.89	4.57	4.15	3.19	056C262B025L1A	140C262B025L1A	180C262B025L1A	L1
	Output OHL (lbs.)	2441	2491	2496	2779	2799	056C262B025LKA	140C262B025LKA	180C262B025LKA	LK
30	Output RPM	82.19	57.53	47.67	38.47	28.60	056C262T030S1A	140C262T030S1A	180C262T030S1A	Taper Hollow
	Mechanical Input HP	5.37	4.45	4.09	3.71	3.10	056C262S030S1A	140C262S030S1A	180C262S030S1A	Str. Hollow
	Output Torque (lb. in.)	3694	4331	4789	5345	5938	056C262B030K1A	140C262B030K1A	180C262B030K1A	K1
	Output HP Rating	4.82	3.95	3.62	3.26	2.70	056C262B030L1A	140C262B030L1A	180C262B030L1A	L1
	Output OHL (lbs.)	2455	2751	2773	2790	2795	056C262B030LKA	140C262B030LKA	180C262B030LKA	LK
38	Output RPM	65.79	46.05	38.16	30.79	22.89	056C262T038S1A	140C262T038S1A	180C262T038S1A	Taper Hollow
	Mechanical Input HP	5.37	4.45	4.03	3.29	2.52	056C262S038S1A	140C262S038S1A	180C262S038S1A	Str. Hollow
	Output Torque (lb. in.)	4616	5410	5893	5918	6016	056C262B038K1A	140C262B038K1A	180C262B038K1A	K1
	Output HP Rating	4.82	3.95	3.57	2.89	2.19	056C262B038L1A	140C262B038L1A	180C262B038L1A	L1
	Output OHL (lbs.)	2507	2781	2796	2802	2923	056C262B038LKA	140C262B038LKA	180C262B038LKA	LK
40	Output RPM	61.64	43.15	35.75	28.85	21.45	056C262T040S1A	140C262T040S1A	180C262T040S1A	Taper Hollow
	Mechanical Input HP	4.25	3.63	3.38	3.07	2.42	056C262S040S1A	140C262S040S1A	180C262S040S1A	Str. Hollow
	Output Torque (lb. in.)	3822	4619	5166	5760	6018	056C262B040K1A	140C262B040K1A	180C262B040K1A	K1
	Output HP Rating	3.74	3.16	2.93	2.64	2.05	056C262B040L1A	140C262B040L1A	180C262B040L1A	L1
	Output OHL (lbs.)	2743	2786	2797	2799	2924	056C262B040LKA	140C262B040LKA	180C262B040LKA	LK
50	Output RPM	49.34	34.54	28.62	23.09	17.17	056C262T050S1A	140C262T050S1A	180C262T050S1A	Taper Hollow
	Mechanical Input HP	4.25	3.63	3.11	2.57	2.00	056C262S050S1A	140C262S050S1A	180C262S050S1A	Str. Hollow
	Output Torque (lb. in.)	4775	5771	5935	6018	6200	056C262B050K1A	140C262B050K1A	180C262B050K1A	K1
	Output HP Rating	3.74	3.16	2.70	2.21	1.69	056C262B050L1A	140C262B050L1A	180C262B050L1A	L1
	Output OHL (lbs.)	2776	2805	2804	2926	2927	056C262B050LKA	140C262B050LKA	180C262B050LKA	LK

NOTE: All units include drilled and tapped mounting holes on the top and bottom surfaces. If optional bolt-on foot is required, order part number 6011253.

FEATURES/BENEFITS PAGE G5-2	SPECIFICATION PAGE G5-4	NOMENCLATURE PAGE G5-5	MODIFICATION/ACCESSORIES PAGE G5-34
--------------------------------	----------------------------	---------------------------	--

SELECTION



Combination TIGEAR Size C262

RATIO	RATING DATA	INPUT RPM					PART NUMBERS			SHAFT POSITION
		2500	1750	1450	1170	870	56C	140TC	180TC	
60	Output RPM	41.10	28.77	23.84	19.23	14.30	056C262T060S1A	140C262T060S1A	---	Taper Hollow
	Mechanical Input HP	3.15	2.73	2.53	2.26	1.73	056C262S060S1A	140C262S060S1A	---	Str. Hollow
	Output Torque (lb. in.)	4101	5012	5555	6070	6133	056C262B060K1A	140C262B060K1A	---	K1
	Output HP Rating	2.67	2.29	2.10	1.85	1.39	056C262B060L1A	140C262B060L1A	---	L1
	Output OHL (lbs.)	2794	2910	2926	2935	3028	056C262B060LKA	140C262B060LKA	---	LK
75	Output RPM	32.89	23.03	19.08	15.39	11.45	056C262T075S1A	140C262T075S1A	---	Taper Hollow
	Mechanical Input HP	3.15	2.59	2.23	1.84	1.41	056C262S075S1A	140C262S075S1A	---	Str. Hollow
	Output Torque (lb. in.)	5124	5928	6086	6138	6205	056C262B075K1A	140C262B075K1A	---	K1
	Output HP Rating	2.67	2.17	1.84	1.50	1.13	056C262B075L1A	140C262B075L1A	---	L1
	Output OHL (lbs.)	2812	2933	2939	3031	3157	056C262B075LKA	140C262B075LKA	---	LK
80	Output RPM	30.82	21.58	17.88	14.42	10.73	SEE NEXT PAGE	---	---	Taper Hollow
	Mechanical Input HP	2.44	2.13	1.81	1.51	1.17	SEE NEXT PAGE	---	---	Str. Hollow
	Output Torque (lb. in.)	4156	5109	5174	5285	5410	056C262B080K1A	140C262B080K1A	---	K1
	Output HP Rating	2.03	1.75	1.47	1.21	0.92	056C262B080L1A	140C262B080L1A	---	L1
	Output OHL (lbs.)	2903	2932	3018	3028	3159	056C262B080LKA	140C262B080LKA	---	LK
90	Output RPM	27.41	19.19	15.90	12.83	9.54	SEE NEXT PAGE	---	---	Taper Hollow
	Mechanical Input HP	2.69	2.20	1.88	1.56	1.19	SEE NEXT PAGE	---	---	Str. Hollow
	Output Torque (lb. in.)	5224	6003	6138	6211	6267	056C262B090K1A	140C262B090K1A	---	K1
	Output HP Rating	2.27	1.83	1.55	1.26	0.95	056C262B090L1A	140C262B090L1A	---	L1
	Output OHL (lbs.)	2918	2937	3027	3029	3166	056C262B090LKA	140C262B090LKA	---	LK
100	Output RPM	24.67	17.27	14.31	11.55	8.59	SEE NEXT PAGE	---	---	Taper Hollow
	Mechanical Input HP	2.44	2.02	1.73	1.42	1.09	SEE NEXT PAGE	---	---	Str. Hollow
	Output Torque (lb. in.)	5192	6041	6172	6205	6295	056C262B100K1A	140C262B100K1A	---	K1
	Output HP Rating	2.03	1.66	1.40	1.14	0.86	056C262B100L1A	140C262B100L1A	---	L1
	Output OHL (lbs.)	2929	2937	3034	3156	3172	056C262B100LKA	140C262B100LKA	---	LK
125	Output RPM	19.74	13.82	11.45	9.24	6.87	SEE NEXT PAGE	---	---	Taper Hollow
	Mechanical Input HP	2.07	1.70	1.48	1.20	0.92	SEE NEXT PAGE	---	---	Str. Hollow
	Output Torque (lb. in.)	5320	6125	6349	6272	6340	056C262B125K1A	140C262B125K1A	---	K1
	Output HP Rating	1.67	1.34	1.15	0.92	0.69	056C262B125L1A	140C262B125L1A	---	L1
	Output OHL (lbs.)	2947	3039	3164	3179	3280	056C262B125LKA	140C262B125LKA	---	LK
150	Output RPM	16.45	11.51	9.54	7.70	5.72	056C262T150S1A	140C262T150S1A	---	Taper Hollow
	Mechanical Input HP	1.91	1.50	1.29	1.07	0.83	056C262S150S1A	140C262S150S1A	---	Str. Hollow
	Output Torque (lb. in.)	5597	6169	6261	6315	6388	056C262B150K1A	140C262B150K1A	---	K1
	Output HP Rating	1.46	1.13	0.95	0.77	0.58	056C262B150L1A	140C262B150L1A	---	L1
	Output OHL (lbs.)	3044	3051	3190	3198	3305	056C262B150LKA	140C262B150LKA	---	LK
160	Output RPM	15.41	10.79	8.94	7.21	5.36	056C262T160S1A	140C262T160S1A	---	Taper Hollow
	Mechanical Input HP	1.72	1.50	1.32	1.11	0.87	056C262S160S1A	140C262S160S1A	---	Str. Hollow
	Output Torque (lb. in.)	5024	6002	6267	6297	6380	056C262B160K1A	140C262B160K1A	---	K1
	Output HP Rating	1.23	1.03	0.89	0.72	0.54	056C262B160L1A	140C262B160L1A	---	L1
	Output OHL (lbs.)	3057	3195	3211	3223	3335	056C262B160LKA	140C262B160LKA	---	LK
200	Output RPM	12.34	8.63	7.15	5.77	4.29	056C262T200S1A	140C262T200S1A	---	Taper Hollow
	Mechanical Input HP	1.70	1.25	1.08	0.90	0.75	056C262S200S1A	140C262S200S1A	---	Str. Hollow
	Output Torque (lb. in.)	6209	6223	6345	6387	6836	056C262B200K1A	140C262B200K1A	---	K1
	Output HP Rating	1.22	0.85	0.72	0.59	0.47	056C262B200L1A	140C262B200L1A	---	L1
	Output OHL (lbs.)	3072	3220	3223	3329	3476	056C262B200LKA	140C262B200LKA	---	LK
240	Output RPM	10.27	7.19	5.96	4.81	3.58	056C262T240S1A	---	---	Taper Hollow
	Mechanical Input HP	1.16	0.88	0.83	0.76	0.66	056C262S240S1A	---	---	Str. Hollow
	Output Torque (lb. in.)	4348	4730	5216	5751	6368	056C262B240K1A	---	---	K1
	Output HP Rating	0.71	0.54	0.49	0.44	0.36	056C262B240L1A	---	---	L1
	Output OHL (lbs.)	3220	3326	3344	3360	3514	056C262B240LKA	---	---	LK
300	Output RPM	8.22	5.76	4.77	3.85	2.86	056C262T300S1A	---	---	Taper Hollow
	Mechanical Input HP	1.01	0.88	0.82	0.68	0.53	056C262S300S1A	---	---	Str. Hollow
	Output Torque (lb. in.)	4694	5909	6436	6436	6436	056C262B300K1A	---	---	K1
	Output HP Rating	0.61	0.54	0.49	0.39	0.29	056C262B300L1A	---	---	L1
	Output OHL (lbs.)	3248	3353	3357	3504	3527	056C262B300LKA	---	---	LK

NOTE: All units include drilled and tapped mounting holes on the top and bottom surfaces. If optional bolt-on foot is required, order part number 6011253.

FEATURES/BENEFITS PAGE G5-2	SPECIFICATION PAGE G5-4	NOMENCLATURE PAGE G5-5	MODIFICATION/ACCESSORIES PAGE G5-34
--------------------------------	----------------------------	---------------------------	--

SELECTION



Combination TIGEAR

Combination TIGEAR Size C262 HOLLOW OUTPUT SHAFT

**NOTE: Ratings for the following ratios are different from Solid Shaft ratings.
This is only applicable to size C262**

RATIO	RATING DATA	INPUT RPM					PART NUMBER			SHAFT POSITION
		2500	1750	1450	1170	870	56C	140TC	180TC	
80	Output RPM	29.85	20.90	17.31	13.97	10.39	056C262T080S1A	140C262T080S1A	---	Taper Hollow Str. Hollow
	Mechanical Input HP	1.91	1.60	1.50	1.35	1.14	056C262S080S1A	140C262S080S1A	---	
	Output Torque (lb. in.)	3008	3620	4035	4400	4861				
	Output HP Rating	1.42	1.20	1.11	0.98	0.80				
	Output OHL (lbs.)	2903	2932	3018	3028	3159				
90	Output RPM	27.50	19.25	15.95	12.87	9.57	056C262T090S1A	140C262T090S1A	---	Taper Hollow Str. Hollow
	Mechanical Input HP	1.75	1.50	1.33	1.13	1.00	056C262S090S1A	140C262S090S1A	---	
	Output Torque (lb. in.)	2868	3373	3529	3607	4115				
	Output HP Rating	1.25	1.03	0.89	0.74	0.62				
	Output OHL (lbs.)	2918	2937	3027	3029	3166				
100	Output RPM	25.00	17.50	14.50	11.70	8.70	056C262T100S1A	140C262T100S1A	---	Taper Hollow Str. Hollow
	Mechanical Input HP	1.91	1.60	1.34	1.35	1.14	056C262S100S1A	140C262S100S1A	---	
	Output Torque (lb. in.)	3591	4322	4275	5254	5804				
	Output HP Rating	1.42	1.20	0.98	0.98	0.80				
	Output OHL (lbs.)	2929	2937	3034	3156	3172				
125	Output RPM	20.55	14.38	11.92	9.62	7.15	056C262T125S1A	140C262T125S1A	---	Taper Hollow Str. Hollow
	Mechanical Input HP	1.91	1.60	1.50	1.31	1.02	056C262S125S1A	140C262S125S1A	---	
	Output Torque (lb. in.)	4480	5258	5861	6243	6314				
	Output HP Rating	1.46	1.20	1.11	0.95	0.72				
	Output OHL (lbs.)	2947	3039	3164	3179	3280				

NOTE: All units include drilled and tapped mounting holes on the top and bottom surfaces. If optional bolt-on foot is required, order part number 6011260.

Engineering

System-1

Index

FEATURES/BENEFITS PAGE G5-2	SPECIFICATION PAGE G5-4	NOMENCLATURE PAGE G5-5	MODIFICATION/ACCESSORIES PAGE G5-34
--------------------------------	----------------------------	---------------------------	--

SELECTION



Combination TIGEAR Size C350

RATIO	RATING DATA	INPUT RPM					PART NUMBERS				SHAFT POSITION
		2500	1750	1450	1170	870	56C	140TC	180TC	210TC	
6.10	Output RPM	415	290	240	194	144	---	140C350T006S1A	180C350T006S1A	210C350T006S1A*	Taper Hollow
	Mechanical Input HP	12.98	11.26	10.33	9.25	8.24	---	140C350S006S1A	180C350S006S1A	210C350S006S1A*	Str. Hollow
	Output Torque (lb. in.)	1811	2229	2459	2714	3225	---	140C350B006K1A	180C350B006K1A	210C350B006K1A*	K1
	Output HP Rating	11.92	10.26	9.38	8.36	7.38	---	140C350B006L1A	180C350B006L1A	210C350B006L1A*	L1
	Output OHL (lbs.)	4251	4377	4445	4524	4626	---	140C350B006LKA	180C350B006LKA	210C350B006LKA*	LK
7.50	Output RPM	333	233	193	156	116	---	140C350T007S1A	180C350T007S1A	210C350T007S1A*	Taper Hollow
	Mechanical Input HP	12.98	11.26	10.33	9.25	8.24	---	140C350S007S1A	180C350S007S1A	210C350S007S1A*	Str. Hollow
	Output Torque (lb. in.)	2253	2772	3059	3376	4011	---	140C350B007K1A	180C350B007K1A	210C350B007K1A*	K1
	Output HP Rating	11.92	10.26	9.38	8.36	7.38	---	140C350B007L1A	180C350B007L1A	210C350B007L1A*	L1
	Output OHL (lbs.)	4302	4421	4484	4559	4604	---	140C350B007LKA	180C350B007LKA	210C350B007LKA*	LK
9.40	Output RPM	265	186	154	124	92	---	140C350T009S1A	180C350T009S1A	210C350T009S1A*	Taper Hollow
	Mechanical Input HP	12.98	11.26	10.33	9.25	8.24	---	140C350S009S1A	180C350S009S1A	210C350S009S1A*	Str. Hollow
	Output Torque (lb. in.)	2831	3483	3843	4242	5040	---	140C350B009K1A	180C350B009K1A	210C350B009K1A*	K1
	Output HP Rating	11.92	10.26	9.38	8.36	7.38	---	140C350B009L1A	180C350B009L1A	210C350B009L1A*	L1
	Output OHL (lbs.)	4336	4407	4409	4412	4355	---	140C350B009LKA	180C350B009LKA	210C350B009LKA*	LK
10	Output RPM	221.20	154.80	128.30	103.50	76.96	---	---	180C350T010S1A	210C350T010S1A*	Taper Hollow
	Mechanical Input HP	12.98	11.26	10.33	9.25	8.24	---	---	180C350S010S1A	210C350S010S1A*	Str. Hollow
	Output Torque (lb. in.)	3396	4179	4611	5089	6046	---	---	180C350B010K1A	210C350B010K1A*	K1
	Output HP Rating	11.92	10.26	9.38	8.36	7.38	---	---	180C350B010L1A	210C350B010L1A*	L1
	Output OHL (lbs.)	4533	4653	4713	4826	4917	---	---	180C350B010LKA	210C350B010LKA*	LK
15	Output RPM	179.10	125.40	103.90	83.82	62.33	---	---	180C350T015S1A	210C350T015S1A*	Taper Hollow
	Mechanical Input HP	12.98	11.26	10.33	9.25	8.24	---	---	180C350S015S1A	210C350S015S1A*	Str. Hollow
	Output Torque (lb. in.)	4193	5160	5693	6284	7466	---	---	180C350B015K1A	210C350B015K1A*	K1
	Output HP Rating	11.92	10.26	9.38	8.36	7.38	---	---	180C350B015L1A	210C350B015L1A*	L1
	Output OHL (lbs.)	4610	4726	4781	4899	4915	---	---	180C350B015LKA	210C350B015LKA*	LK
18	Output RPM	150.00	105.00	87.00	70.20	52.20	---	---	180C350T018S1A	210C350T018S1A*	Taper Hollow
	Mechanical Input HP	12.98	11.26	10.33	9.25	8.11	---	---	180C350S018S1A	210C350S018S1A*	Str. Hollow
	Output Torque (lb. in.)	5007	6161	6798	7503	8768	---	---	180C350B018K1A	210C350B018K1A*	K1
	Output HP Rating	11.92	10.26	9.38	8.36	7.26	---	---	180C350B018L1A	210C350B018L1A*	L1
	Output OHL (lbs.)	4674	4785	4788	4957	4853	---	---	180C350B018LKA	210C350B018LKA*	LK
20	Output RPM	123.30	86.30	71.51	57.70	42.90	---	---	180C350T020S1A	210C350T020S1A*	Taper Hollow
	Mechanical Input HP	12.98	11.26	10.33	8.83	7.11	---	---	180C350S020S1A	210C350S020S1A*	Str. Hollow
	Output Torque (lb. in.)	6092	7496	8271	8714	9343	---	---	180C350B020K1A	210C350B020K1A*	K1
	Output HP Rating	11.92	10.26	9.38	7.98	6.36	---	---	180C350B020L1A	210C350B020L1A*	L1
	Output OHL (lbs.)	4742	4800	4717	4919	5195	---	---	180C350B020LKA	210C350B020LKA*	LK
25	Output RPM	98.68	69.08	57.24	46.18	34.34	---	---	180C350T025S1A	210C350T025S1A*	Taper Hollow
	Mechanical Input HP	12.98	10.13	8.82	7.53	6.06	---	---	180C350S025S1A	210C350S025S1A*	Str. Hollow
	Output Torque (lb. in.)	7611	8414	8805	9268	9946	---	---	180C350B025K1A	210C350B025K1A*	K1
	Output HP Rating	11.92	9.22	8.00	6.79	5.42	---	---	180C350B025L1A	210C350B025L1A*	L1
	Output OHL (lbs.)	4814	4717	4595	4820	5131	---	---	180C350B025LKA	210C350B025LKA*	LK
30	Output RPM	82.19	57.53	47.67	38.47	28.60	---	---	180C350T030S1A	210C350T030S1A*	Taper Hollow
	Mechanical Input HP	10.10	8.51	7.71	6.62	5.37	---	---	180C350S030S1A	210C350S030S1A*	Str. Hollow
	Output Torque (lb. in.)	7014	8376	9110	9634	10408	---	---	180C350B030K1A	210C350B030K1A	K1
	Output HP Rating	9.15	7.65	6.89	5.88	4.72	---	---	180C350B030L1A	210C350B030L1A	L1
	Output OHL (lbs.)	4784	4925	4812	5170	5012	---	---	180C350B030LKA	210C350B030LKA	LK
38	Output RPM	65.79	46.05	38.16	30.79	22.89	---	---	180C350T038S1A	210C350T038S1A*	Taper Hollow
	Mechanical Input HP	10.10	7.56	6.59	5.65	4.58	---	---	180C350S038S1A	210C350S038S1A*	Str. Hollow
	Output Torque (lb. in.)	8763	9281	9712	10251	11061	---	---	180C350B038K1A	210C350B038K1A	K1
	Output HP Rating	9.15	6.78	5.88	5.01	4.02	---	---	180C350B038L1A	210C350B038L1A	L1
	Output OHL (lbs.)	4695	4823	5183	5079	5505	---	---	180C350B038LKA	210C350B038LKA	LK
40	Output RPM	61.64	43.15	35.75	28.85	21.45	---	---	180C350T040S1A	210C350T040S1A*	Taper Hollow
	Mechanical Input HP	8.34	6.94	6.32	5.53	4.56	---	---	140C350S040S1A	180C350S040S1A	Str. Hollow
	Output Torque (lb. in.)	7491	8935	9778	10341	11286	---	---	140C350B040K1A	180C350B040K1A	K1
	Output HP Rating	7.33	6.12	5.55	4.73	3.84	---	---	140C350B040L1A	180C350B040L1A	L1
	Output OHL (lbs.)	4972	5197	5151	5056	5502	---	---	140C350B040LKA	180C350B040LKA	LK
50	Output RPM	49.34	34.54	28.62	23.09	17.17	---	---	180C350T050S1A	210C350T050S1A*	Taper Hollow
	Mechanical Input HP	8.14	6.19	5.40	4.72	3.89	---	---	140C350S050S1A	180C350S050S1A	Str. Hollow
	Output Torque (lb. in.)	9125	9943	10403	10993	12014	---	---	140C350B050K1A	180C350B050K1A	K1
	Output HP Rating	7.14	5.45	4.72	4.03	3.27	---	---	140C350B050L1A	180C350B050L1A	L1
	Output OHL (lbs.)	4893	5154	5046	5517	5414	---	---	140C350B050LKA	180C350B050LKA	LK

* Thermal limitations may apply. Consult DODGE Application Engineering

NOTE: All units include drilled and tapped mounting holes on the top and bottom surfaces. If optional bolt-on foot is required, order part number 6011277.

FEATURES/BENEFITS PAGE G5-2	SPECIFICATION PAGE G5-4	NOMENCLATURE PAGE G5-5	MODIFICATION/ACCESSORIES PAGE G5-34
--------------------------------	----------------------------	---------------------------	--



Combination TIGEAR Size C350

RATIO	RATING DATA	INPUT RPM					PART NUMBERS				SHAFT POSITION
		2500	1750	1450	1170	870	56C	140TC	180TC	210TC	
60	Output RPM	41.10	28.77	23.84	19.23	14.30	056C350T060S1A	140C350T060S1A	180C350T060S1A	--	Taper Hollow Str. Hollow K1 L1 LK
	Mechanical Input HP	6.80	5.36	4.75	4.23	3.51	056C350S060S1A	140C350S060S1A	180C350S060S1A	--	
	Output Torque (lb. in.)	8995	9983	10883	11593	12654	056C350B060K1A	140C350B060K1A	180C350B060K1A	--	
	Output HP Rating	5.87	4.56	4.12	3.54	2.87	056C350B060L1A	140C350B060L1A	180C350B060L1A	--	
	Output OHL (lbs.)	5217	5064	5496	5461	5285	056C350B060LKA	140C350B060LKA	180C350B060LKA	--	
75	Output RPM	32.89	23.03	19.08	15.39	11.45	056C350T075S1A	140C350T075S1A	180C350T075S1A	--	Taper Hollow Str. Hollow K1 L1 LK
	Mechanical Input HP	6.08	5.00	4.06	3.62	2.90	056C350S075S1A	140C350S075S1A	180C350S075S1A	--	
	Output Torque (lb. in.)	10027	11619	11590	12357	13057	056C350B075K1A	140C350B075K1A	180C350B075K1A	--	
	Output HP Rating	5.23	4.24	3.51	3.02	2.37	056C350B075L1A	140C350B075L1A	180C350B075L1A	--	
	Output OHL (lbs.)	4875	4875	4875	4875	4875	056C350B075LKA	140C350B075LKA	180C350B075LKA	--	
80	Output RPM	30.82	21.58	17.88	14.42	10.73	056C350T080S1A	140C350T080S1A	180C350T080S1A	--	Taper Hollow Str. Hollow K1 L1 LK
	Mechanical Input HP	5.58	4.63	4.12	3.57	2.85	056C350S080S1A	140C350S080S1A	180C350S080S1A	--	
	Output Torque (lb. in.)	9502	11034	11740	12444	13014	056C350B080K1A	140C350B080K1A	180C350B080K1A	--	
	Output HP Rating	4.65	3.78	3.33	2.85	2.21	056C350B080L1A	140C350B080L1A	180C350B080L1A	--	
	Output OHL (lbs.)	5131	5542	5465	5333	5712	056C350B080LKA	140C350B080LKA	180C350B080LKA	--	
86	Output RPM	30.00	21.00	17.40	14.14	10.44	056C350T086S1A	140C350T086S1A	180C350T086S1A	--	Taper Hollow Str. Hollow K1 L1 LK
	Mechanical Input HP	4.70	4.20	3.55	3.17	2.76	056C350S086S1A	140C350S086S1A	180C350S086S1A	--	
	Output Torque (lb. in.)	7988	9997	10055	10996	12478	056C350B086K1A	140C350B086K1A	180C350B086K1A	--	
	Output HP Rating	3.80	3.33	2.78	2.45	2.07	056C350B086L1A	140C350B086L1A	180C350B086L1A	--	
	Output OHL (lbs.)	5515	5515	5515	5515	5515	056C350B086LKA	140C350B086LKA	180C350B086LKA	--	
100	Output RPM	24.67	17.27	14.31	11.55	8.59	056C350T100S1A	140C350T100S1A	180C350T100S1A	--	Taper Hollow Str. Hollow K1 L1 LK
	Mechanical Input HP	5.02	3.99	3.53	3.01	2.30	056C350S100S1A	140C350S100S1A	180C350S100S1A	--	
	Output Torque (lb. in.)	10640	11838	12518	13053	13069	056C350B100K1A	140C350B100K1A	180C350B100K1A	--	
	Output HP Rating	4.17	3.24	2.84	2.39	1.78	056C350B100L1A	140C350B100L1A	180C350B100L1A	--	
	Output OHL (lbs.)	5003	5462	5343	5149	5577	056C350B100LKA	140C350B100LKA	180C350B100LKA	--	
125	Output RPM	19.74	13.82	11.45	9.24	6.87	056C350T125S1A	140C350T125S1A	180C350T125S1A	--	Taper Hollow Str. Hollow K1 L1 LK
	Mechanical Input HP	4.42	3.51	3.04	2.49	1.91	056C350S125S1A	140C350S125S1A	180C350S125S1A	--	
	Output Torque (lb. in.)	11391	12652	13057	13069	13069	056C350B125K1A	140C350B125K1A	180C350B125K1A	--	
	Output HP Rating	3.57	2.77	2.37	1.92	1.42	056C350B125L1A	140C350B125L1A	180C350B125L1A	--	
	Output OHL (lbs.)	5541	5339	5176	5651	5886	056C350B125LKA	140C350B125LKA	180C350B125LKA	--	
150	Output RPM	16.45	11.51	9.54	7.70	5.72	056C350T150S1A	140C350T150S1A	180C350T150S1A	--	Taper Hollow Str. Hollow K1 L1 LK
	Mechanical Input HP	4.03	3.08	2.62	2.15	1.65	056C350S150S1A	140C350S150S1A	180C350S150S1A	--	
	Output Torque (lb. in.)	12156	12891	13069	13069	13069	056C350B150K1A	140C350B150K1A	180C350B150K1A	--	
	Output HP Rating	3.17	2.35	1.98	1.60	1.19	056C350B150L1A	140C350B150L1A	180C350B150L1A	--	
	Output OHL (lbs.)	5478	5207	5702	5539	5780	056C350B150LKA	140C350B150LKA	180C350B150LKA	--	
160	Output RPM	15.41	10.79	8.94	7.21	5.36	056C350T160S1A	140C350T160S1A	180C350T160S1A	--	Taper Hollow Str. Hollow K1 L1 LK
	Mechanical Input HP	3.20	2.70	2.46	2.20	1.63	056C350S160S1A	140C350S160S1A	180C350S160S1A	--	
	Output Torque (lb. in.)	9561	11116	12025	13069	13069	056C350B160K1A	140C350B160K1A	180C350B160K1A	--	
	Output HP Rating	2.34	1.90	1.71	1.50	1.11	056C350B160L1A	140C350B160L1A	180C350B160L1A	--	
	Output OHL (lbs.)	5495	5829	4942	5590	5777	056C350B160LKA	140C350B160LKA	180C350B160LKA	--	
200	Output RPM	12.34	8.63	7.15	5.77	4.29	056C350T200S1A	140C350T200S1A	180C350T200S1A	--	Taper Hollow Str. Hollow K1 L1 LK
	Mechanical Input HP	3.20	2.55	2.15	1.77	1.31	056C350S200S1A	140C350S200S1A	180C350S200S1A	--	
	Output Torque (lb. in.)	11944	13069	13069	13069	13069	056C350B200K1A	140C350B200K1A	180C350B200K1A	--	
	Output HP Rating	2.34	1.79	1.48	1.20	0.89	056C350B200L1A	140C350B200L1A	180C350B200L1A	--	
	Output OHL (lbs.)	5361	5766	4585	5891	6259	056C350B200LKA	140C350B200LKA	180C350B200LKA	--	
240	Output RPM	10.27	7.19	5.96	4.81	3.58	056C350T240S1A	140C350T240S1A	180C350T240S1A	--	Taper Hollow Str. Hollow K1 L1 LK
	Mechanical Input HP	2.39	1.85	1.73	1.57	1.28	056C350S240S1A	140C350S240S1A	180C350S240S1A	--	
	Output Torque (lb. in.)	9831	10340	11475	12539	13069	056C350B240K1A	140C350B240K1A	180C350B240K1A	--	
	Output HP Rating	1.60	1.18	1.08	0.96	0.74	056C350B240L1A	140C350B240L1A	180C350B240L1A	--	
	Output OHL (lbs.)	5864	5731	5407	5856	6326	056C350B240LKA	140C350B240LKA	180C350B240LKA	--	
300	Output RPM	8.22	5.76	4.77	3.85	2.86	056C350T300S1A	140C350T300S1A	180C350T300S1A	--	Taper Hollow Str. Hollow K1 L1 LK
	Mechanical Input HP	2.39	1.85	1.58	1.32	1.03	056C350S300S1A	140C350S300S1A	180C350S300S1A	--	
	Output Torque (lb. in.)	12282	12918	13069	13069	13069	056C350B300K1A	140C350B300K1A	180C350B300K1A	--	
	Output HP Rating	1.60	1.18	0.99	0.80	0.59	056C350B300L1A	140C350B300L1A	180C350B300L1A	--	
	Output OHL (lbs.)	5760	5976	5104	6341	6167	056C350B300LKA	140C350B300LKA	180C350B300LKA	--	

NOTE: All units include drilled and tapped mounting holes on the top and bottom surfaces. If optional bolt-on foot is required, order part number 6011277.

FEATURES/BENEFITS PAGE G5-2	SPECIFICATION PAGE G5-4	NOMENCLATURE PAGE G5-5	MODIFICATION/ACCESSORIES PAGE G5-34
--------------------------------	----------------------------	---------------------------	--

DIMENSIONS



Combination TIGEAR Size C150 HOLLOW SHAFT - TAPERED BUSHING

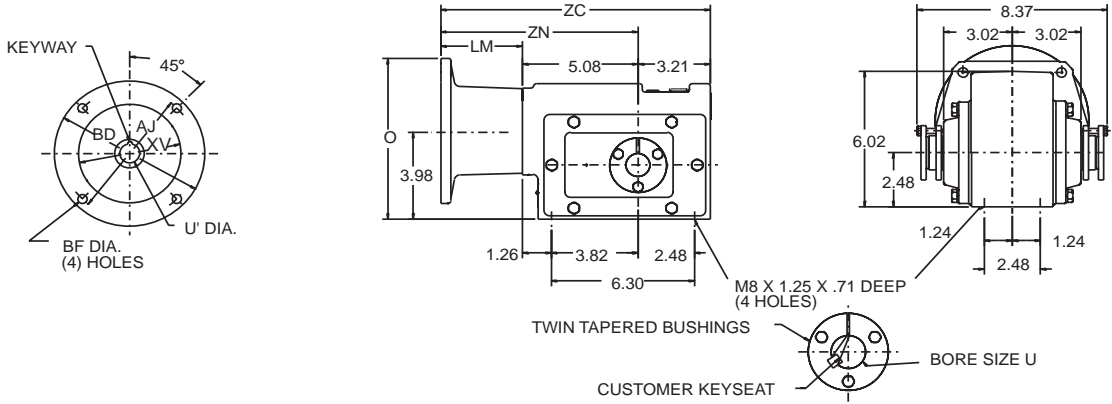

FRAME SIZE	AJ	BD	BF	U'		KEYWAY	XV (TENON)	ZC	O	LM	ZN
				MIN.	MAX.						
56C	5.88	6.72	0.44	0.626	0.627	3/16 X 3/32	4.501/4.503	11.89	7.34	3.60	8.68
140TC	5.88	6.72	0.44	0.876	0.877	3/16 X 3/32	4.501/4.503	11.89	7.34	3.60	8.68

U	CUSTOMER KEYSEAT REQ'D
1-1/8	1/4 X 1/8 X 7.66
1-1/16	
1-3/16	
1"	
25MM	8MM x 4MM
30MM	

HOLLOW SHAFT - STRAIGHT BORE

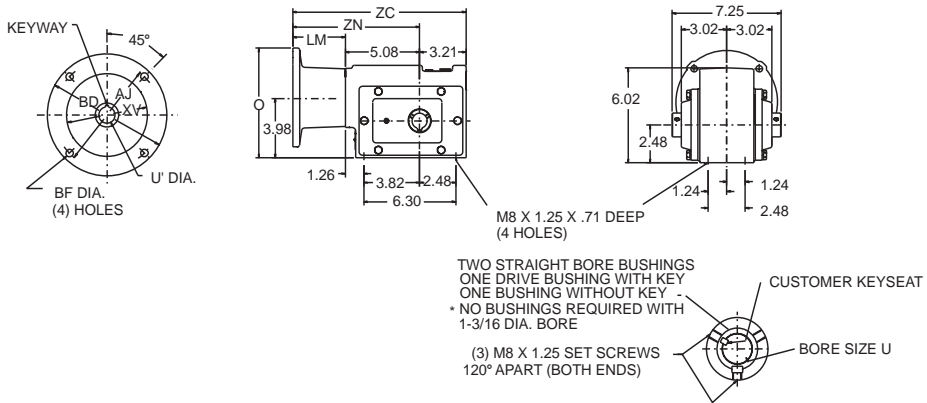

FRAME SIZE	AJ	BD	BF	U'		KEYWAY	XV (TENON)	ZC	O	LM	ZN
				MIN.	MAX.						
56C	5.88	6.72	0.44	0.626	0.627	3/16 X 3/32	4.501/4.503	11.89	7.34	3.60	8.68
140TC	5.88	6.72	0.44	0.876	0.877	3/16 X 3/32	4.501/4.503	11.89	7.34	3.60	8.68

U	CUSTOMER KEYSEAT REQ'D
1-3/16"	1/4 X 1/8 X 1"
1-1/8	
1-1/16	
1	

FEATURES/BENEFITS PAGE G5-2	SPECIFICATION PAGE G5-4	NOMENCLATURE PAGE G5-5	MODIFICATION/ACCESSORIES PAGE G5-34
--------------------------------	----------------------------	---------------------------	--

DIMENSIONS/ MOUNTING POSITIONS



Combination TIGEAR Size C150 SOLID SHAFT

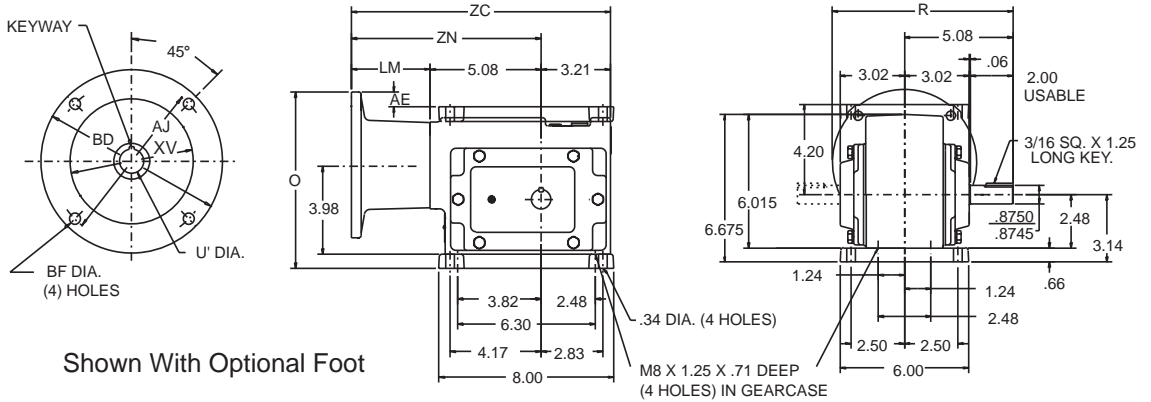

FRAME SIZE	AJ	BD	BF	U'		KEYWAY	XV (TENON)	ZC	O	LM	ZN	AE	R
				MIN.	MAX.								
56C	5.88	6.72	0.44	0.626	0.627	3/16 X 3/32	4.501/4.503	11.86	8.00	3.60	8.68	0.66	8.44
140TC	5.88	6.72	0.44	0.876	0.877	3/16 X 3/32	4.501/4.503	11.86	8.00	3.60	8.68	0.66	8.44

NOTE: All units include drilled and tapped mounting holes on the top and bottom of the reducer. If optional bolt-on foot is required, order part number 6011246.

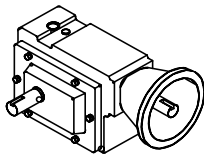

K-1

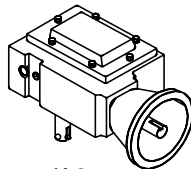

K-2

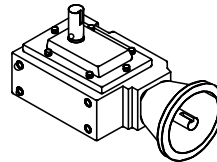

K-4

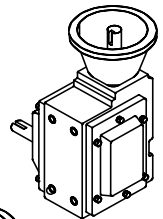

K-5

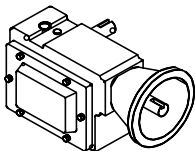

L-1

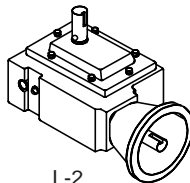

L-2

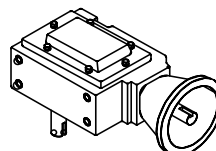

L-4

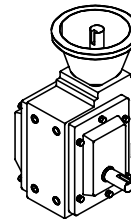

L-5

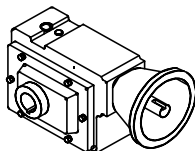

S-1

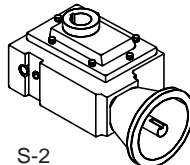

S-2

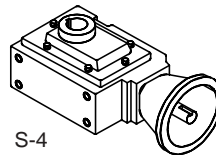

S-4

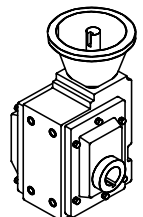

S-5

For Additional Mounting Positions, Refer To Pages G5-32 and G5-33

FEATURES/BENEFITS PAGE G5-2	SPECIFICATION PAGE G5-4	NOMENCLATURE PAGE G5-5	MODIFICATION/ACCESSORIES PAGE G5-34
--------------------------------	----------------------------	---------------------------	--

DIMENSIONS



Combination TIGEAR Size C200 HOLLOW SHAFT - TAPERED BUSHING

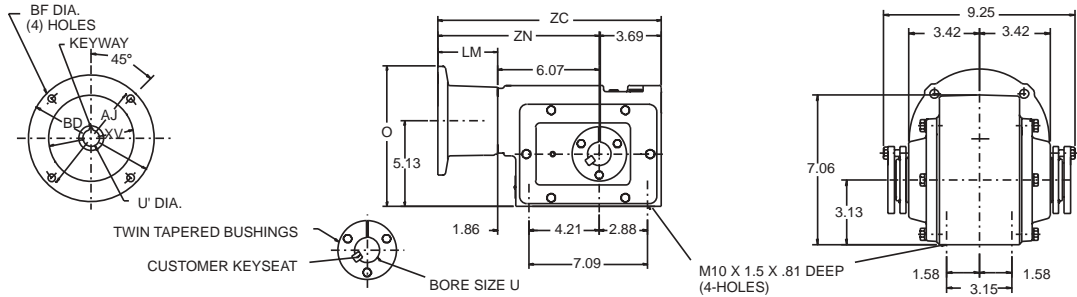

FRAME SIZE	AJ	BD	BF	U'		KEYWAY	XV (TENON)	ZC	O	LM	ZN
				MIN.	MAX.						
56C	5.88	6.72	0.44	0.626	0.627	3/16 X 3/32	4.501/4.503	13.37	8.38	3.60	9.67
140TC	5.88	6.72	0.44	0.876	0.877	3/16 X 3/32	4.501/4.503	13.37	8.38	3.60	9.67
180TC	7.25	9.00	0.53	1.126	1.127	1/4 X 1/8	8.500/8.502	14.41	9.66	4.64	10.71

U	CUSTOMER KEYSEAT REQ'D
1-7/16	3/8 X 3/16 X 8.82
1-3/8	1/4 X 1/8 X 8.82
1-5/16	
1-1/4	
1-3/16	
1-1/8	
1-1/16	10MM X 5MM X 225MM
1	
35MM	
32MM	
30MM	8MM X 4MM X 225MM
25MM	

HOLLOW SHAFT - STRAIGHT BORE

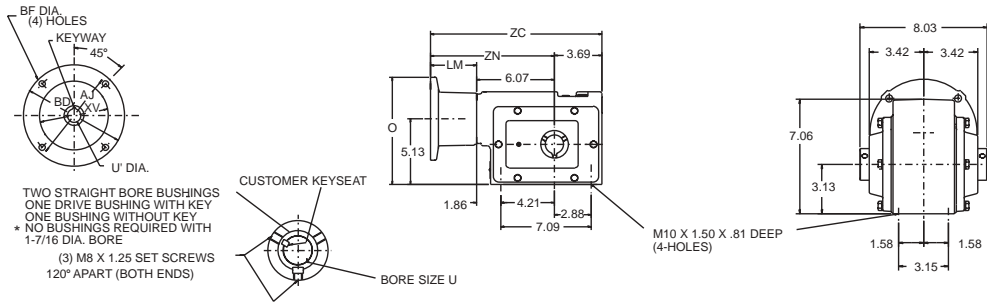

FRAME SIZE	AJ	BD	BF	U'		KEYWAY	XV (TENON)	ZC	O	LM	ZN
				MIN.	MAX.						
56C	5.88	6.72	0.44	0.626	0.627	3/16X3/32	4.501/4.503	13.37	8.38	3.60	9.67
140TC	5.88	6.72	0.44	0.876	0.877	3/16 X 3/32	4.501/4.503	13.37	8.38	3.60	9.67
180TC	7.25	9.00	0.53	1.126	1.127	1/4X 1/8	8.500/8.502	14.41	9.66	4.64	10.71

U	CUSTOMER KEYSEAT REQ'D
1-7/16*	3/8 X 3/16 X 2
1-5/16	5/16 X 5/32 X 2
1-1/4	1/4X1/8X2
1-3/16	
1-1/8	1/4 X 1/8 X 1-3/4
1-1/16	
1	

FEATURES/BENEFITS PAGE G5-2	SPECIFICATION PAGE G5-4	NOMENCLATURE PAGE G5-5	MODIFICATION/ACCESSORIES PAGE G5-34
--------------------------------	----------------------------	---------------------------	--

DIMENSIONS/ MOUNTING POSITIONS



Combination TIGEAR Size C200 SOLID SHAFT

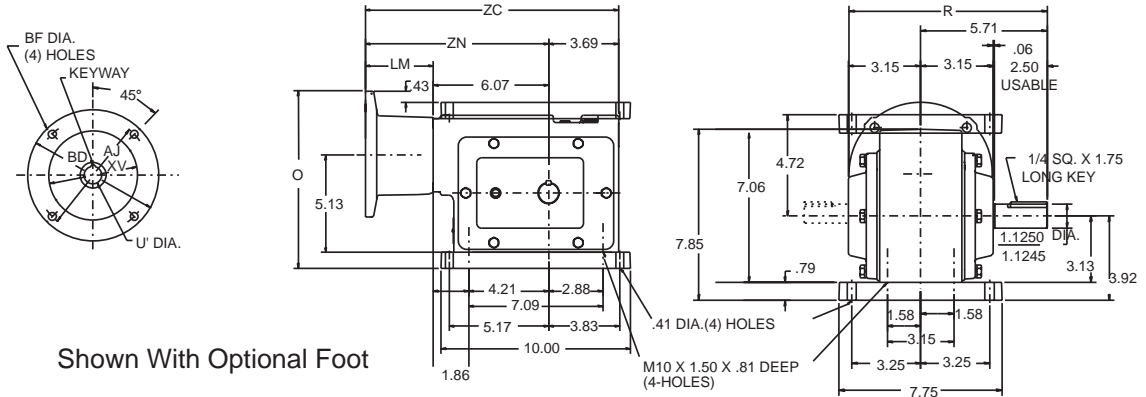

Shown With Optional Foot

FRAME SIZE	AJ	BD	BF	U'		KEYWAY	XV (TENON)	ZC	O	R	LM	ZN
				MIN.	MAX.							
56C	5.88	6.72	0.44	0.626	0.627	3/16 X 3/32	4.501/4.503	13.37	9.17	8.96	3.60	9.67
140TC	5.88	6.72	0.44	0.876	0.877	3/16 X 3/32	4.501/4.503	13.37	9.17	8.96	3.60	9.67
180TC	7.25	9.00	0.53	1.126	1.127	1/4 X 1/8	8.500/8.502	14.41	10.45	10.21	4.64	10.71

NOTE: All units include drilled and tapped mounting holes on the top and bottom of the reducer. If optional bolt-on foot is required, order part number 6011253.

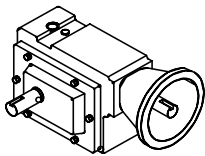

K-1

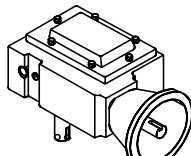

K-2

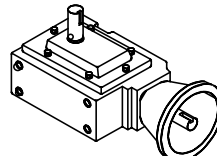

K-4

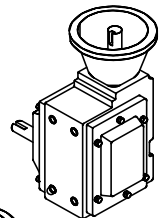

K-5

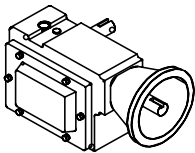

L-1

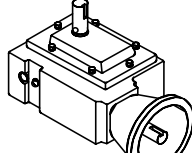

L-2

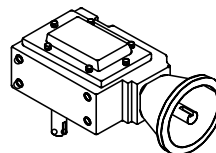

L-4

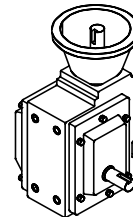

L-5

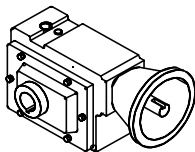

S-1

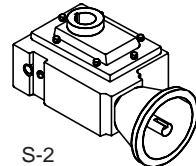

S-2

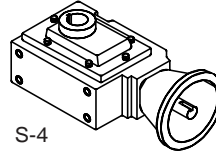

S-4

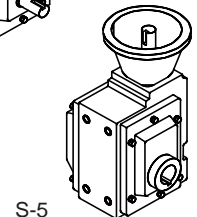

S-5

For Additional Mounting Positions, Refer To Pages G5-32 and G5-33

FEATURES/BENEFITS PAGE G5-2	SPECIFICATION PAGE G5-4	NOMENCLATURE PAGE G5-5	MODIFICATION/ACCESSORIES PAGE G5-34
--------------------------------	----------------------------	---------------------------	--

DIMENSIONS



Combination TIGEAR Size C262 HOLLOW SHAFT - TAPERED BUSHING

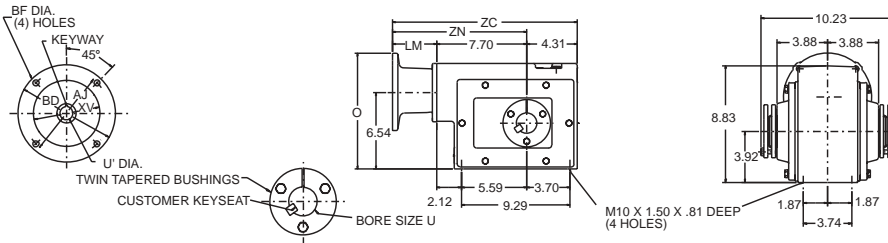

FRAME SIZE	AJ	BD	BF	U'		KEYWAY	XV (TENON)	ZC	O	LM	ZN
				MIN.	MAX.						
56C	5.88	6.72	0.44	0.626	0.627	3/16 X 3/32	4.501/4.503	15.81	9.90	3.80	11.50
140TC	5.88	6.72	0.44	0.876	0.877	3/16 X 3/32	4.501/4.503	15.81	9.90	3.80	11.50
180TC	7.25	9.00	0.53	1.126	1.127	1/4 X 1/8	8.500/8.502	16.81	11.04	4.80	12.50

U	CUSTOMER KEYSEAT REQ'D
1-15/16	1/2 X 1/4 X 9.81 MAX
1-3/4	3/8 X 3/16 X 9.81
1-11/16	
1-5/8	
1-1/2	
1-7/16	5/16 X 5/32 X 9.81
1-3/8	
1-5/16	
1-1/4	1/4 X 1/8 X 9.81
1-3/16	
1-1/8	12MM X 5MM X 250MM
45MM	
42MM	
40MM	
38MM	10MM X 5MM X 250MM
35MM	
32MM	

HOLLOW SHAFT - STRAIGHT BORE

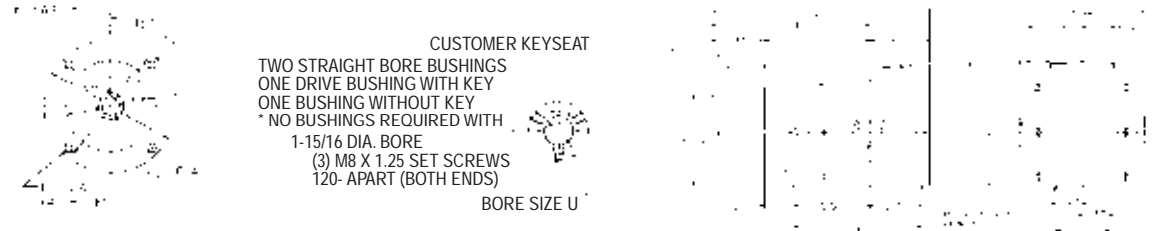

FRAME SIZE	AJ	BD	BF	U'		KEYWAY	XV (TENON)	ZC	O	LM	ZN
				MIN.	MAX.						
56C	5.88	6.72	0.44	0.626	0.627	3/16 X 3/32	4.501/4.503	15.81	9.90	3.80	11.50
140TC	5.88	6.72	0.44	0.876	0.877	3/16 X 3/32	4.501/4.503	15.81	9.90	3.80	11.50
180TC	7.25	9.00	0.53	1.126	1.127	1/4 X 1/8	8.500/8.502	16.81	11.04	4.80	12.50

U	CUSTOMER KEYSEAT REQ'D
1-15/16*	1/2 X 1/4 X 2-1/2
1-3/4	3/8 X 3/16 X 2-7/8
1-11/16	
1-5/8	
1-1/2	
1-7/16	3/8 X 3/16 X 2-1/2
1-3/8	
1-5/16	
1-1/4	5/16 X 5/32 X 2
1-3/16	
1-3/16	1/4 X 1/8 X 2

FEATURES/BENEFITS PAGE G5-2	SPECIFICATION PAGE G5-4	NOMENCLATURE PAGE G5-5	MODIFICATION/ACCESSORIES PAGE G5-34
--------------------------------	----------------------------	---------------------------	--

DIMENSIONS/ MOUNTING POSITIONS



Combination TIGEAR Size C262 SOLID SHAFT

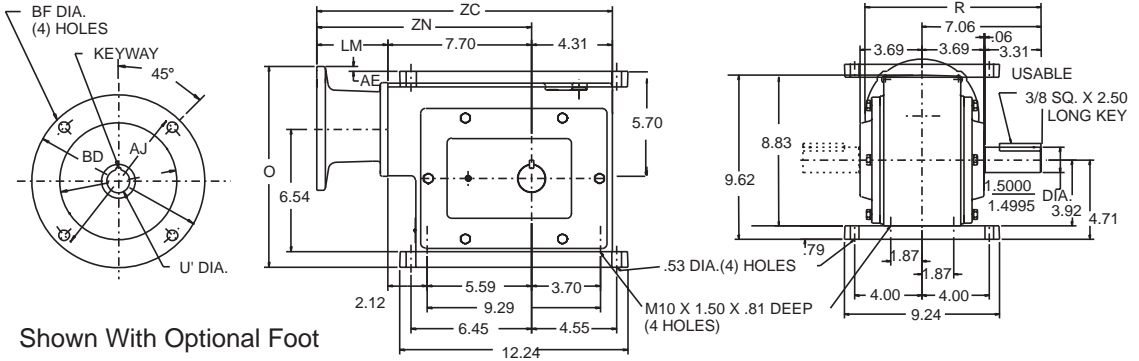

Shown With Optional Foot

FRAME SIZE	AJ	BD	BF	U'		KEYWAY	XV (TENON)	ZC	O	R	LM	ZN	AE
				MIN.	MAX.								
56C	5.88	6.72	0.44	0.626	0.627	3/16 X 3/32	4.501/4.503	15.81	10.69	10.63	3.80	11.50	0.28
140TC	5.88	6.72	0.44	0.876	0.877	3/16 X 3/32	4.501/4.503	15.81	10.69	10.63	3.80	11.50	0.28
180TC	7.25	9.00	0.53	1.126	1.127	1/4 X 1/8	8.500/8.502	16.81	11.83	11.78	4.80	12.50	1.42

NOTE: All units include drilled and tapped mounting holes on the bottom of the reducer. If optional bolt-on foot is required, order part number 6011260.

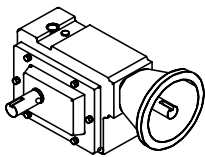

K-1

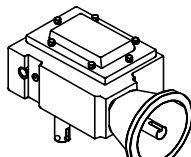

K-2

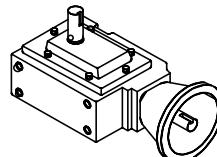

K-4

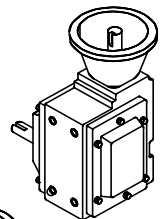

K-5

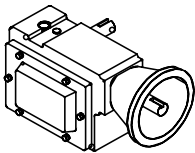

L-1

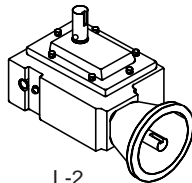

L-2

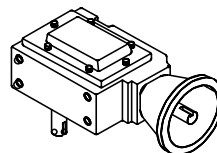

L-4

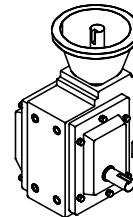

L-5

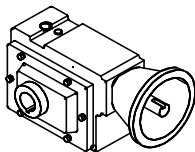

S-1

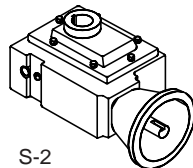

S-2

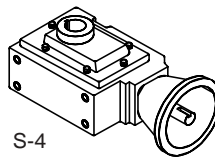

S-4

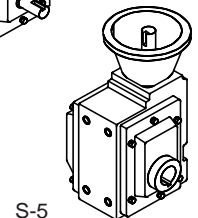

S-5

For Additional Mounting Positions, Refer To Pages G5-32 and G5-33

FEATURES/BENEFITS PAGE G5-2	SPECIFICATION PAGE G5-4	NOMENCLATURE PAGE G5-5	MODIFICATION/ACCESSORIES PAGE G5-34
--------------------------------	----------------------------	---------------------------	--

DIMENSIONS



Combination TIGEAR Size C350 HOLLOW SHAFT - TAPERED BUSHING

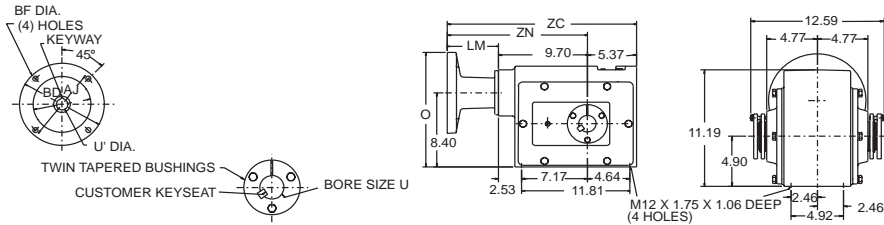

FRAME SIZE	AJ	BD	BF	U'		KEYWAY	XV (TENON)	ZC	O	LM	ZN
				MIN.	MAX.						
56C	5.88	6.72	0.44	0.626	0.627	3/16 X 3/32	4.501/4.503	18.87	11.76	3.80	13.50
140TC	5.88	6.72	0.44	0.876	0.877	3/16 X 3/32	4.501/4.503	18.87	11.76	3.80	13.50
180TC	7.25	9.00	0.53	1.126	1.127	1/4 X 1/8	8.500/8.502	19.87	12.90	4.80	14.50
210TC	7.25	9.00	0.53	1.376	1.377	5/16 X 5/32	8.500/8.502	20.37	12.90	5.30	15.00

U	CUSTOMER KEYSEAT REQ'D
2-3/16 MAX 2 1-15/16 1-7/8	1/2 X 1/4 X 12.09
1-3/4 1-11/16 1-5/8 1-1/2 1-7/16	3/8 X 3/16 X 12.09
1-3/8 1-5/16	5/16 X 5/32 X 9.81
55MM	16MM X 6MM X 307MM
50MM	14MM X 6MM X 307MM
45MM	
42MM	
40MM 38MM	12MM X 5MM X 307MM

HOLLOW SHAFT - STRAIGHT BORE

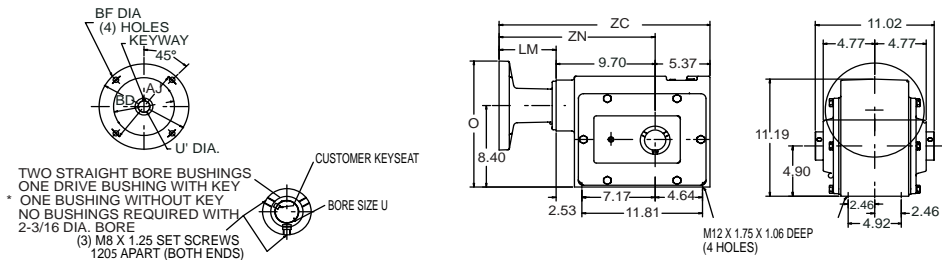

FRAME SIZE	AJ	BD	BF	U'		KEYWAY	XV (TENON)	ZC	O	LM	ZN
				MIN.	MAX.						
56C	5.88	6.72	0.44	0.626	0.627	3/16 X 3/32	4.501/4.503	18.87	11.76	3.80	13.50
140TC	5.88	6.72	0.44	0.876	0.877	3/16 X 3/32	4.501/4.503	18.87	11.76	3.80	13.50
180TC	7.25	9.00	0.53	1.126	1.127	1/4 X 1/8	8.500/8.502	19.87	12.90	4.80	14.50
210TC	7.25	9.00	0.53	1.376	1.377	5/16 X 5/32	8.500/8.502	20.37	12.90	5.30	15.00

U	CUSTOMER KEYSEAT REQ'D
2-3/16* 2 1-15/16 1-7/8	1/2 X 1/4 X 3-5/8
1-3/4 1-11/16	3/8 X 3/16 X 3-1/4
1-5/8 1-1/2 1-7/16	3/8 X 3/16 X 2-1/4
1-3/8 1-5/16	5/16 X 5/32 X 2-1/4

FEATURES/BENEFITS PAGE G5-2	SPECIFICATION PAGE G5-4	NOMENCLATURE PAGE G5-5	MODIFICATION/ACCESSORIES PAGE G5-34
--------------------------------	----------------------------	---------------------------	--

DIMENSIONS/ MOUNTING POSITIONS



Combination TIGEAR Size C350

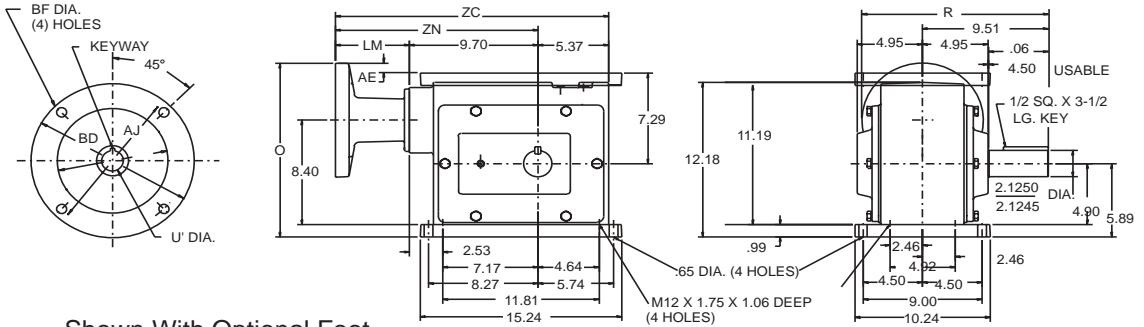

Shown With Optional Foot

FRAME SIZE	AJ	BD	BF	U'		KEYWAY	XV (TENON)	ZC	O	R	LM	ZN	AE
				MIN.	MAX.								
56C	5.88	6.72	0.44	0.626	0.627	3/16 X 3/32	4.501/4.503	18.87	12.75	12.97	3.80	13.50	-0.43
140TC	5.88	6.72	0.44	0.876	0.877	3/16 X 3/32	4.501/4.503	18.87	12.75	12.97	3.80	13.50	-0.43
180TC	7.25	9.00	0.53	1.126	1.127	1/4 X 1/8	8.500/8.502	19.87	13.89	14.18	4.80	14.50	0.71
210TC	7.25	9.00	0.53	1.376	1.377	5/16 X 5/32	8.500/8.502	20.37	13.89	14.18	5.30	15.00	0.71

NOTE: All units include drilled and tapped mounting holes on the top and bottom of the reducer. If optional bolt-on foot is required, order part number 6011277.

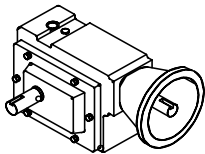

K-1

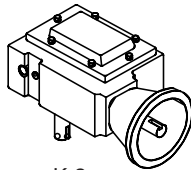

K-2

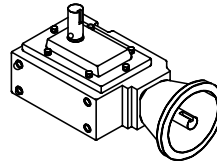

K-4

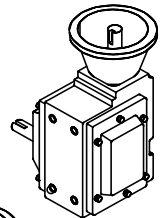

K-5

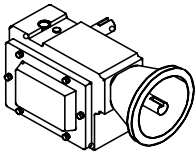

L-1

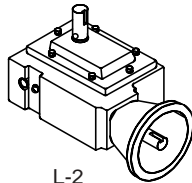

L-2

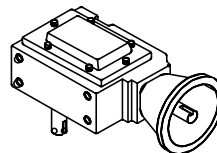

L-4

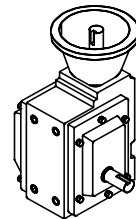

L-5

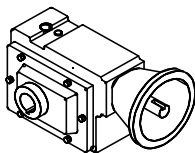

S-1

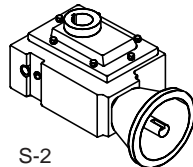

S-2

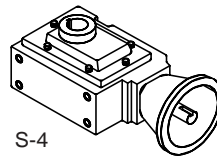

S-4

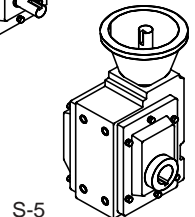

S-5

For Additional Mounting Positions, Refer To Pages G5-32 and G5-33

FEATURES/BENEFITS PAGE G5-2	SPECIFICATION PAGE G5-4	NOMENCLATURE PAGE G5-5	MODIFICATION/ACCESSORIES PAGE G5-34
--------------------------------	----------------------------	---------------------------	--

MOUNTING POSITIONS



Combination TIGEAR (Shown with optional Bolt-on Foot)

Foot On Bottom

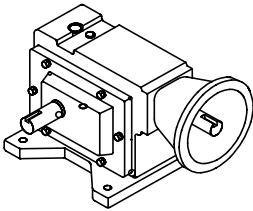

K-1

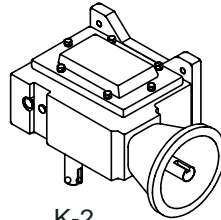

K-2

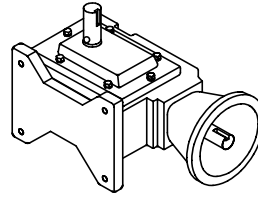

K-4

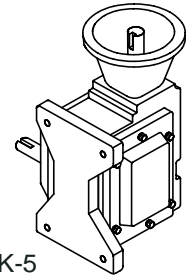

K-5

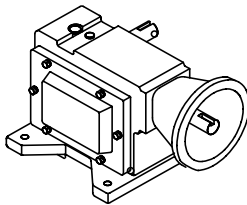

L-1

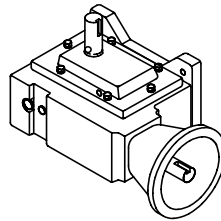

L-2

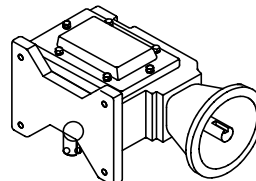

L-4

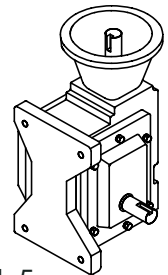

L-5

Foot On Top

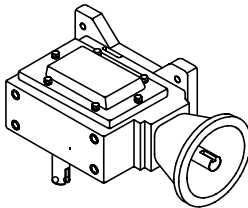

A-1

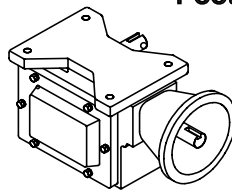

A-3

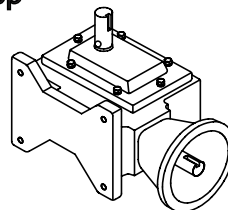

A-4

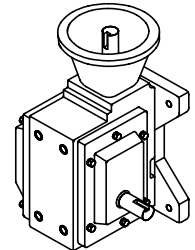

A-5

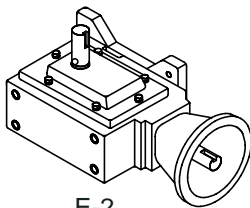

E-2

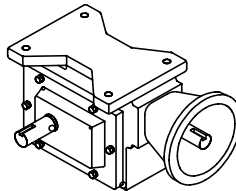

E-3

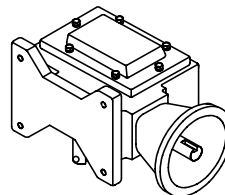

E-4

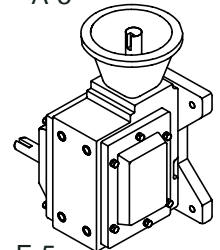

E-5

MOUNTING POSITIONS



Combination TIGEAR (Shown with optional Bolt-on Foot)

Solid Output Shaft

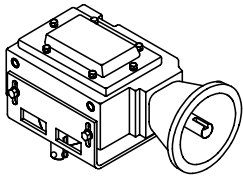

B-1

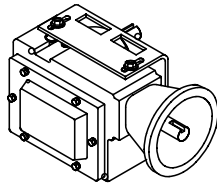

B-2

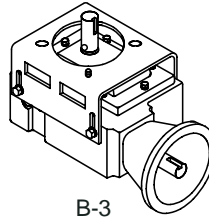

B-3

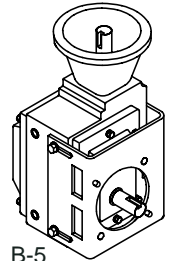

B-5

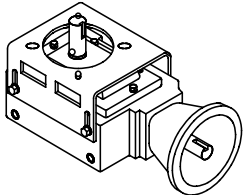

H-3

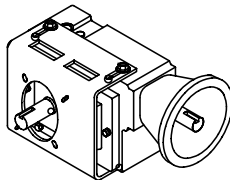

H-4

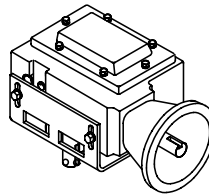

H-1

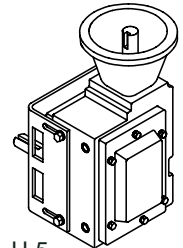

H-5

Hollow Output Shaft

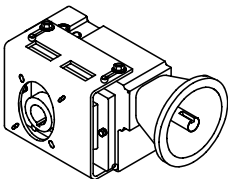

H-4

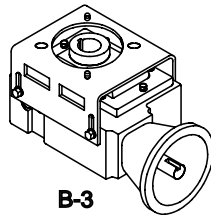

B-3

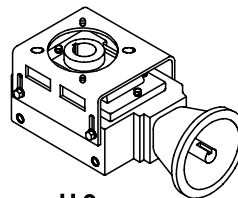

H-3

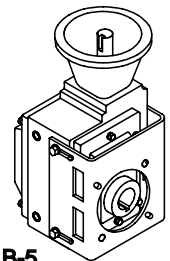

B-5

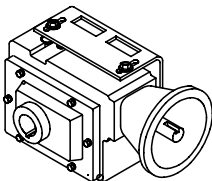

B-2

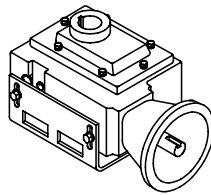

H-1

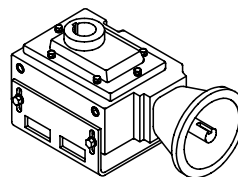

B-1

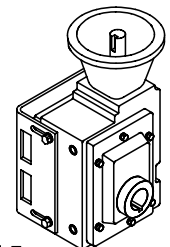

H-5

FEATURES/BENEFITS
PAGE G5-2

NOMENCLATURE
PAGE G5-5

DIMENSIONS
PAGE G5-24

MODIFICATION/ACCESSORIES
PAGE G5-34

MODIFICATIONS/ ACCESSORIES



Combination TIGEAR BOLT-ON FOOT



All Combination TIGEAR units include drilled and tapped mounting holes on the bottom of the reducer, but do not include the base. Kits listed below include a cast iron bolt-on-foot and the required mounting hardware.

Reducer Case Size	Kit Number
150	6011246
200	6011253
262	6011260
350	6011277

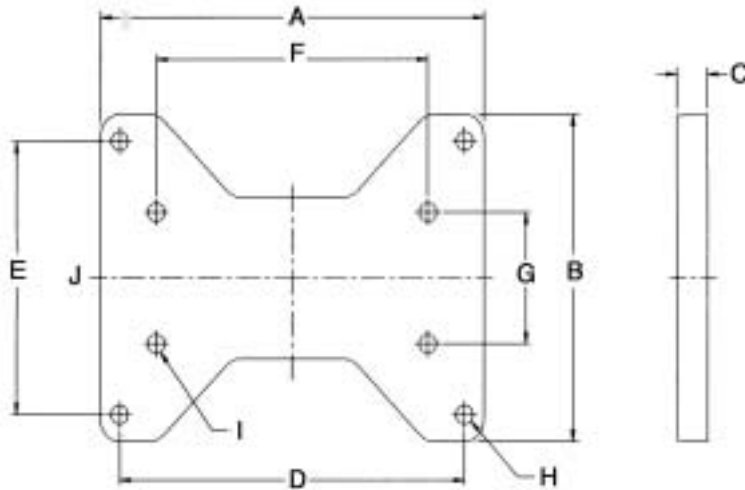

SIZE	A	B	C	D	E	F	G	H	I	J
150	8.00	6.00	0.66	7.00	5.00	6.30	2.48	0.34	0.38	3.29
200	10.00	7.76	0.79	9.00	6.50	7.09	3.15	0.41	0.41	3.55
262	12.24	9.24	0.79	11.00	8.00	9.29	3.74	0.53	0.41	4.53
350	15.24	10.24	0.99	14.00	9.00	11.81	4.92	0.65	0.50	5.94

FEATURES/BENEFITS PAGE G5-2	SPECIFICATION PAGE G5-4	NOMENCLATURE PAGE G5-5	RENEWAL PARTS PAGE G5-45
--------------------------------	----------------------------	---------------------------	-----------------------------



Combination TIGEAR TIE ROD KIT



The Tie Rod Kit is available for restraining Straight Bore and Tapered Bore Hollow Shaft Reducers. Each kit includes reducer mounting brackets, tie rods, turnbuckle, fulcrum and mounting hardware.

Reducer Case Size	Tie Rod Kit	Mounting Brackets Only Includes Hardware
150	6009878	6009861
200	6002503	6009885
262	6009915	6009908
350	6009953	6009922

	A MIN. - MAX.	B	C	D	E	F
C150	14.75 - 17.75	3.57	0.39	2.50	0.94	1.13
C200	14.75 - 17.75	4.22	0.39	2.50	0.94	1.37
C262	14.75 - 17.75	5.01	0.39	2.50	0.94	0.95
C350	19.50 - 25.50	5.83	0.45	3.00	1.06	1.50

	G	H	I	J	K	L	M
C150	7.25	7.58	1.09	1.25	2.48	0.60	2.50
C200	8.00	8.70	1.09	1.50	3.13	0.68	2.63
C262	9.75	10.52	1.09	1.50	3.92	0.94	3.93
C350	13.00	13.27	0.93	1.50	4.90	1.26	5.00

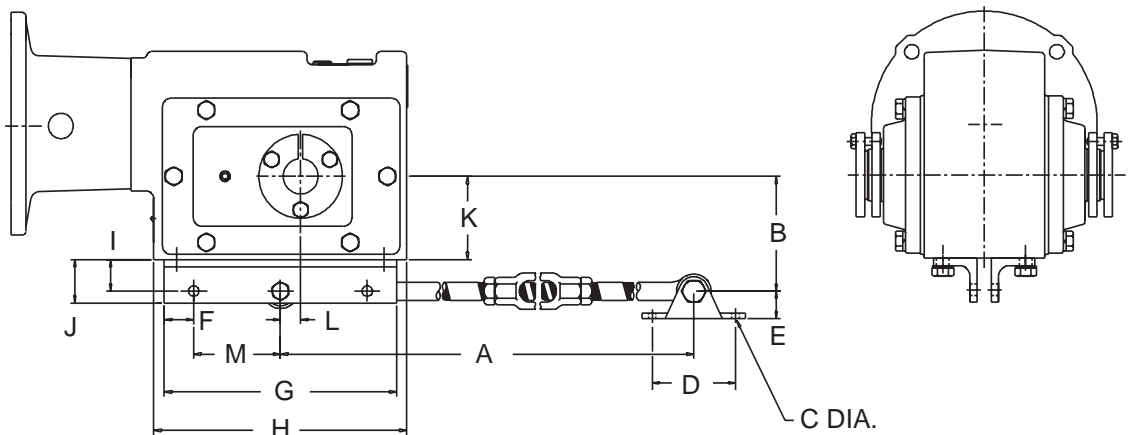

FEATURES/BENEFITS PAGE G5-2	SPECIFICATION PAGE G5-4	NOMENCLATURE PAGE G5-5	RENEWAL PARTS PAGE G5-45
--------------------------------	----------------------------	---------------------------	-----------------------------

MODIFICATIONS/ ACCESSORIES



Combination TIGEAR OUTPUT FLANGE



The Output Flange Kit is used to mount the reducer to a flat surface perpendicular to the output shaft. On Hollow Shaft units, an output flange may be substituted for a tie rod kit to restrain reactions. Each kit consists of a fabricated steel flange and required mounting hardware.

CASE SIZE	KIT MODEL NO. (B MTG.)	KIT MODEL NO. (H MTG.)
C150	6011710	6011673
C200	6011727	6011680
C262	6011734	6011697
C350	6011741	6011703

CASE SIZE	A MIN.	A MAX.	BF	AJ
C150	3.27	5.50	4.00	5.12
C200	3.60	6.21	*6.31	N/A
C262	4.26	6.93	6.51	8.51
C350	5.40	8.21	8.46	12.50

CASE SIZE	B	C	D	E	F DIA.	G DIA. (TYP.)	H DIA. (TYP.)
C150	2.68	6.42	2.98	7.30	3.12	0.36	0.41
C200	3.41	7.59	3.63	8.50	5.12	SEE DIAGRAM 1	
C262	4.24	9.47	4.18	10.25	5.12	0.54	0.41
C350	5.28	11.95	5.23	13.00	7.09	0.56	0.56

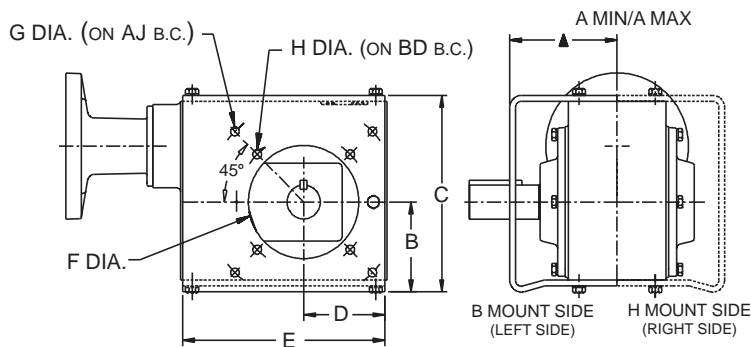

* BOLT CIRCLE TO CENTER OF SLOT
NOTE: 1) FLANGE DIMENSIONS THE SAME FOR ALL SHAFT CONFIGURATIONS

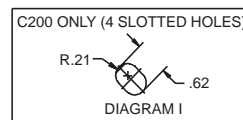

FEATURES/BENEFITS PAGE G5-2	SPECIFICATION PAGE G5-4	NOMENCLATURE PAGE G5-5	RENEWAL PARTS PAGE G5-45
--------------------------------	----------------------------	---------------------------	-----------------------------



Combination TIGEAR RISER BLOCK KITS



Riser blocks allow clearance over the motor eliminating the need to invert the reducer (worm under) when the application calls for a “ceiling” mount such as under a conveyor or other equipment. Riser blocks permit the reducer to be mounted in the most desirable position keeping the high speed shaft seal above the oil level. Experience shows that this results in increased seal life and durability. Each kit includes the riser block and required mounting hardware.

CASE SIZE	MOTOR FRAME SIZE	KIT MODEL NUMBER	“B” (MM)	“B” (IN) +.00/-.02 .02	“A” RISER BLOCK (IN)”
C150	56/140	6011789	140	5.51	1.29
C200	56/140	6011796	140	5.51	0.77
	180	6011987	180	7.09	2.35
C262	56/140	6011802	160	6.30	0.58
	180	6011994	200	7.87	2.15
C350	56/140	6011819	200	7.87	0.57
	180/210	6012007	225	8.86	1.56

Note: Dimension B includes optional Bolt-On Foot

DODGE COMBINATION TIGEAR

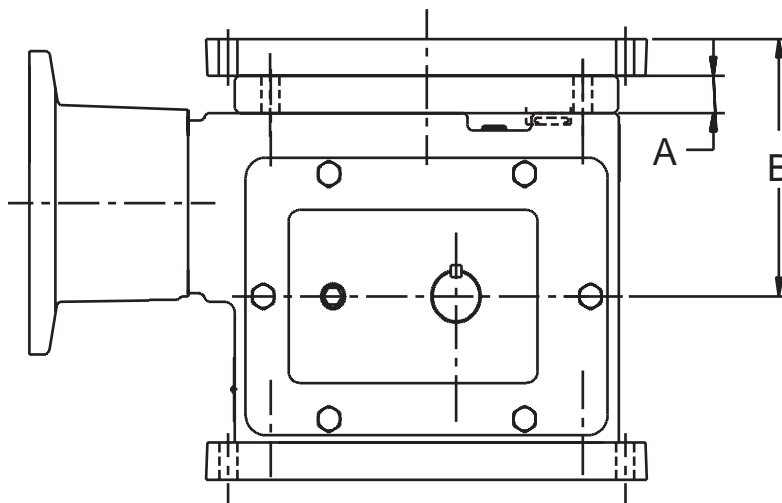



Combination TIGEAR J-MOUNT KITS



J-mount kits allow the reducer to be “floor” mounted with the motor in a vertical (up) position. In this configuration, the output shaft(s) is horizontal. Each kit includes two brackets and the required mounting hardware.

CASE SIZE	KIT NO.	A	B	D	E	F (BOLT)
C150	6011826	200MM 7.87"	63MM 2.48"	90MM 3.54"	86.4MM 3.40"	8MM 5/16"
C200	6011833	250MM 9.84"	80MM 3.15"	100MM 3.94"	114.8MM 4.52"	10MM 3/8"
C262	6011840	315MM 12.40"	100MM 3.94"	125MM 4.92"	144MM 5.67"	10MM 3/8"
C350	6011857	400MM 15.75"	125MM 4.92"	160MM 6.30"	182.4MM 7.18"	12MM 1/2"

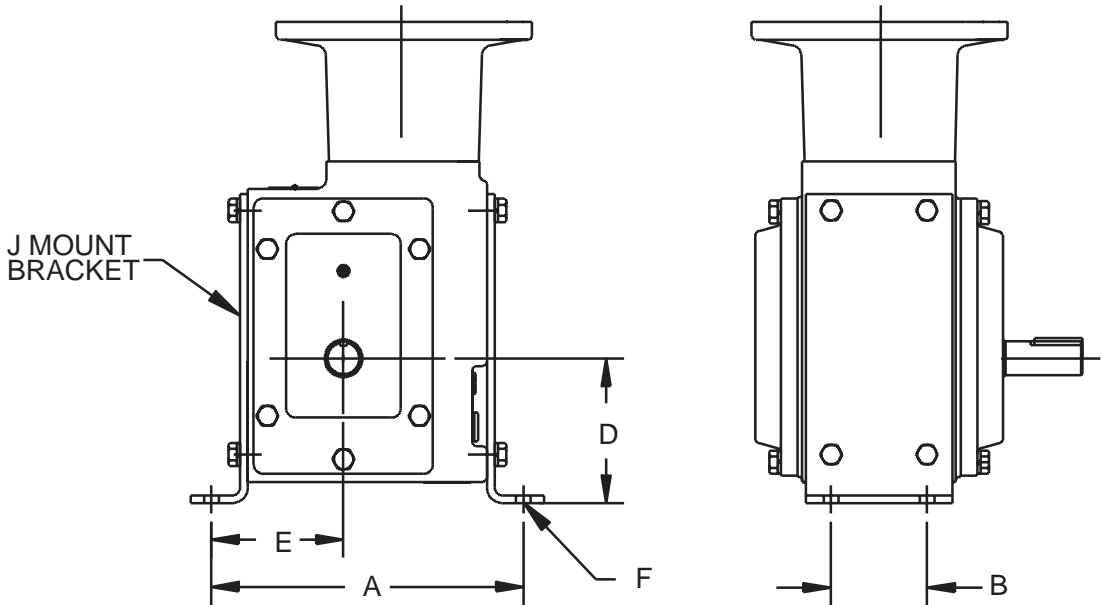

FEATURES/BENEFITS PAGE G5-2	SPECIFICATION PAGE G5-4	NOMENCLATURE PAGE G5-5	RENEWAL PARTS PAGE G5-45
--------------------------------	----------------------------	---------------------------	-----------------------------



Combination TIGEAR HI-LOW BRACKET KITS

Hi-Low bracket kits allow the reducer to be “floor” mounted with the solid or hollow output shaft in a vertical (up) position. In this configuration, the motor is horizontal. Each kit includes two brackets and the required mounting hardware.

CASE SIZE	DESCRIPTION	KIT NUMBER	A	B	D	D'	D''	E	F(BOLT)
C150	"Hi" Mount Solid Shaft	6011864	200MM 7.87"	160MM 6.30"	140MM 5.51"	N/A	N/A	86.4MM 3.40"	8MM 5/16"
	"Hi" Mount Hollow Shaft	6011871			N/A	112MM 4.41"	N/A		
	"Low" Mount Hollow & Solid Shaft	6011888			N/A	N/A	90MM 3.54"		
C200	"Hi" Mount Solid Shaft	6011895	250MM 9.84"	180MM 7.09"	160MM 6.30"	N/A	N/A	114.8MM 4.52"	10MM 3/8"
	"Hi" Mount Hollow Shaft	6011901			N/A	125MM 4.92"	N/A		
	"Low" Mount Hollow & Solid Shaft	6011918			N/A	N/A	90MM 3.54"		
C262	"Hi" Mount Solid Shaft	6011925	315MM 12.40"	236MM 9.29"	200MM 7.87"	N/A	N/A	145MM 5.71"	10MM 3/8"
	"Hi" Mount Hollow Shaft	6011932			N/A	140MM 5.51"	N/A		
	"Low" Mount Hollow & Solid Shaft	6011949			N/A	N/A	112MM 4.41"		
C350	"Hi" Mount Solid Shaft	6011956	400MM 15.75"	300MM 11.81"	250MM 9.84"	N/A	N/A	182.4MM 7.18"	12MM 1/2"
	"Hi" Mount Hollow Shaft	6011963			N/A	180MM 7.09"	N/A		
	"Low" Mount Hollow & Solid Shaft	6011970			N/A	N/A	140MM 5.51"		

"Hi" Bracket - Solid Shaft

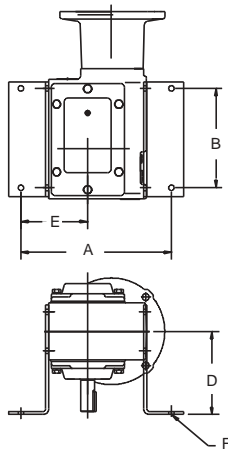

"Hi" Bracket - Hollow Shaft
(Straight & Tapered)

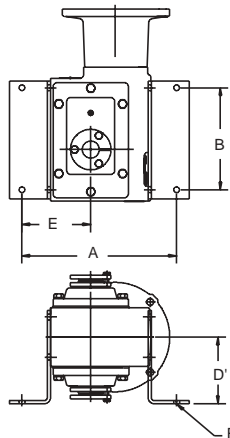

"Low" Bracket
Hollow & Solid Shaft

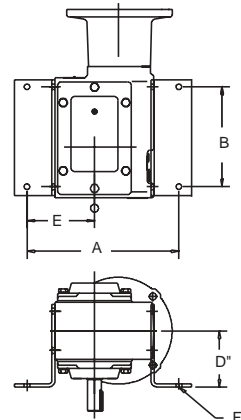

FEATURES/BENEFITS PAGE G5-2	SPECIFICATION PAGE G5-4	NOMENCLATURE PAGE G5-5	RENEWAL PARTS PAGE G5-45
--------------------------------	----------------------------	---------------------------	-----------------------------

MODIFICATIONS/ ACCESSORIES



Combination TIGEAR STRAIGHT BORE BUSHING KITS



Bushing kits are not included with reducers. They must be ordered separately by indicating the bore size or the kit number from the table. Each kit includes two bushings and the required mounting hardware.

Straight Bore Bushing Kits

REDUCER SIZE	BORE SIZE	KIT NUMBER	REDUCER SIZE	BORE SIZE	KIT NUMBER
C150	1	6011475	C262	1-5/8	6011543
	1-1/16	6011772		1-11/16	6011550
	1-1/8	6011758		1-3/4	6011567
	1-3/16	*		1-15/16	*
C200	1	6002602	C350	1-5/16	6011574
	1-1/16	6002619		1-3/8	6011581
	1-1/8	6002626		1-7/16	6011598
	1-3/16	6002633		1-1/2	6011604
	1-1/4	6002640		1-5/8	6011611
	1-5/16	6002657		1-11/16	6011628
	1-7/16	*		1-3/4	6011635
C262	1-3/16	6011482		1-7/8	6011642
	1-1/4	6011499		1-15/16	6011659
	1-5/16	6011505		2	6011666
	1-3/8	6011512		2 3/16	*
	1-7/16	6011529			
	1-1/2	6011536			

* Reducers are shipped from the factory as maximum bore. For other bore sizes, order the appropriate kit from the above chart.

FEATURES/BENEFITS PAGE G5-2	SPECIFICATION PAGE G5-4	NOMENCLATURE PAGE G5-5	RENEWAL PARTS PAGE G5-45
--------------------------------	----------------------------	---------------------------	-----------------------------



Combination TIGEAR TAPERED BUSHING KITS



Bushing kits are not included with reducers. They must be ordered separately by indicating the bore size or the kit number from the table. Each kit includes two bushings and the required mounting hardware. Optional Teflon Coated bushings are available for those applications requiring extra protection in corrosive and wet environments. For ease of ordering, refer to the table below.

TAPERED BUSHING KITS

REDUCER SIZE	BORE SIZE	KIT NUMBER	REDUCER SIZE	BORE SIZE	KIT NUMBER
C150	1	6011000	C262	1-11/16	6011031
	1-1/16	6011765		1-3/4	6011024
	1-1/8	6010997		1-15/16	6011017
	1-3/16	6011284		32 MM	6011352
	25 MM	6011291		35 MM	6011369
	30 MM	6011307		38 MM	6011376
C200	1	6002510	40 MM	6011383	
	1-1/16	6002527	42 MM	6011390	
	1-1/8	6002534	45 MM	6011406	
	1-3/16	6002541	C350	1-5/16	6011222
	1-1/4	6002558		1-3/8	6011215
	1-5/16	6002565		1-7/16	6011208
	1-3/8	6002572		1-1/2	6011192
	1-7/16	6002589		1-5/8	6011185
	25 MM	6011314		1-11/16	6011178
	30 MM	6011321		1-3/4	6011161
	32 MM	6011338		1-7/8	6011154
	35 MM	6011345		1-15/16	6011147
C262	1-1/8	6011116		2	6011130
	1-3/16	6011109		2-3/16	6011123
	1-1/4	6011093		38 MM	6011413
	1-5/16	6011086	40 MM	6011420	
	1-3/8	6011079	42 MM	6011437	
	1-7/16	6011062	45 MM	6011444	
	1-1/2	6011055	50 MM	6011451	
	1-5/8	6011048	55 MM	6011468	

TEFLON COATED TAPERED BUSHING KITS

REDUCER SIZE	BORE SIZE	KIT NUMBER	REDUCER SIZE	BORE SIZE	KIT NUMBER
C150	1	6031121	C262	1-11/16	6031381
	1-1/16	6031138		1-3/4	6031398
	1-1/8	6031145		1-15/16	6031404
	1-3/16	6031152		32 MM	6031411
	25 MM	6031169		35 MM	6031428
	30 MM	6031176		38 MM	6031435
C200	1	6031183	40 MM	6031442	
	1-1/16	6031190	42 MM	6031459	
	1-1/8	6031206	45 MM	6031466	
	1-3/16	6031213	C350	1-5/16	6031473
	1-1/4	6031220		1-3/8	6031480
	1-5/16	6031237		1-7/16	6031497
	1-3/8	6031244		1-1/2	6031503
	1-7/16	6031251		1-5/8	6031510
	25 MM	6031268		1-11/16	6031527
	30 MM	6031275		1-3/4	6031534
	32 MM	6031282		1-7/8	---
	35 MM	6031299		1-15/16	6031541
C262	1-1/8	6031305		2	6031558
	1-3/16	6031312		2-3/16	6031565
	1-1/4	6031329		38 MM	6031572
	1-5/16	6031336	40 MM	6031589	
	1-3/8	6031343	42 MM	6031596	
	1-7/16	6031350	45 MM	6031602	
	1-1/2	6031367	50 MM	6031619	
	1-5/8	6031374	55 MM	6031626	

MODIFICATIONS/ ACCESSORIES



Combination TIGEAR PLUG-IN OUTPUT SHAFT KITS



Plug-In Output Shaft Kits are available to easily convert tapered bored Combination TIGEAR reducers to a solid shaft reducer. Output shafts are available in both standard CRS and stainless steel materials. *Kits include shaft and key.*

Standard CRS Material

Case Size	Kit Number	*U Dimensions
C150	6031725	1-3/16
C200	6031732	1-7/16
C262	6031749	1-15/16
C350	6031756	2-3/16

Stainless Steel Material

Case Size	Kit Number	*U Dimensions
C150	6031763	1-3/16
C200	6031770	1-7/16
C262	6031787	1-15/16
C350	6031794	2-3/16

* Maximum Bore Bushing

NOTE: Output shaft dimensions same as on solid output shaft reducers



Combination TIGEAR IEC METRIC MOTOR ADAPTERS

IEC Metric motor adapters are available with B5 flanges. To order reducer with metric motor adapter use same part number format found on selection pages and substitute the Nema frame size with a three position IEC frame size. Example: 071C200B030K1A. A flexible 3-piece coupling and motor mounting bolts are also included.

REDUCER SIZE	IEC FRAME
C150-C200	IEC71
C150-C200	IEC80
C150-C200	IEC90
C262-C350	IEC71
C262-C350	IEC80
C262-C350	IEC90
C262-C350	IEC100/112
C262-C350	IEC132

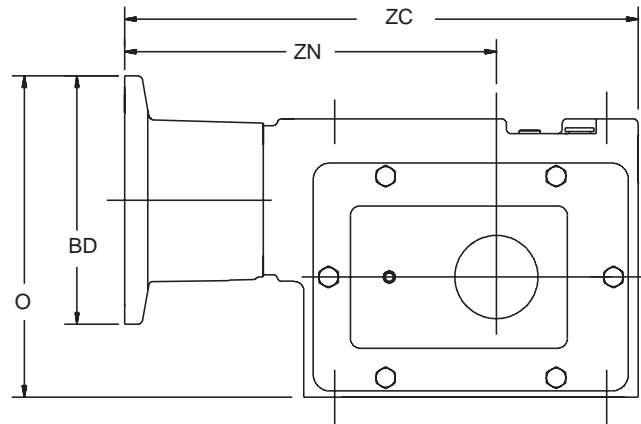
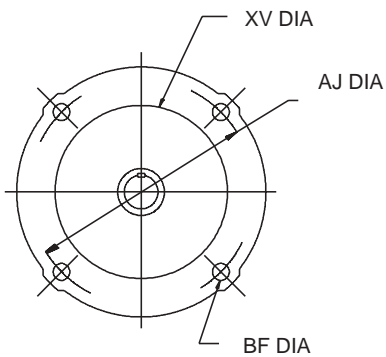

SIZE	FRAME	ZN	ZC	BD	O	AJ	BF	XV
C150	71	7.86	11.07	6.30	7.13	130 MM	M8 TAP	110 MM
	80	8.25	11.46	7.87	7.92	165 MM	11 MM HOLE	130 MM
	90	8.64	11.85	7.87	7.92	165 MM	11 MM HOLE	130 MM
C200	71	8.85	12.54	6.30	8.28	130 MM	M8 TAP	110 MM
	80	9.24	12.93	7.87	9.07	165 MM	11 MM HOLE	130 MM
	90	9.63	13.32	7.87	9.07	165 MM	11 MM HOLE	130 MM
C262	71	10.63	14.94	6.30	9.69	130 MM	M8 TAP	110 MM
	80	11.03	15.34	7.87	10.48	165 MM	11 MM HOLE	130 MM
	90	11.42	15.73	7.87	10.48	165 MM	11 MM HOLE	130 MM
	100/112	13.50	17.81	9.85	11.47	215 MM	14 MM HOLE	180 MM
C350	71	12.63	18.00	6.30	11.55	130 MM	M8 TAP	110 MM
	80	13.03	18.40	7.87	12.34	165 MM	11 MM HOLE	130 MM
	90	13.42	18.79	7.87	12.34	165 MM	11 MM HOLE	130 MM
	110/112	15.50	20.87	9.85	13.33	215 MM	14 MM HOLE	180 MM

FEATURES/BENEFITS PAGE G5-2	SPECIFICATION PAGE G5-4	NOMENCLATURE PAGE G5-5	RENEWAL PARTS PAGE G5-45
--------------------------------	----------------------------	---------------------------	-----------------------------

MODIFICATIONS/ ACCESSORIES



Combination TIGEAR STAINLESS STEEL SHAFT GUARDS

Shaft guards are available for both the solid and hollow shaft gear units and provide protection from the rotating solid output shaft and bushings on the hollow shaft reducers. They are installed by removing the two (2) existing bearing housing bolts (A & B) located on the horizontal centerline of the gearcase and placing the same (2) bolts through the shaft guard and reinstalling to the proper tightening torque. (Bolt torques are listed in Installation Manual)

One (1) piece guards and a two (2) piece guard are available depending on output shaft configuration. **Each kit contains one shaft guard.**

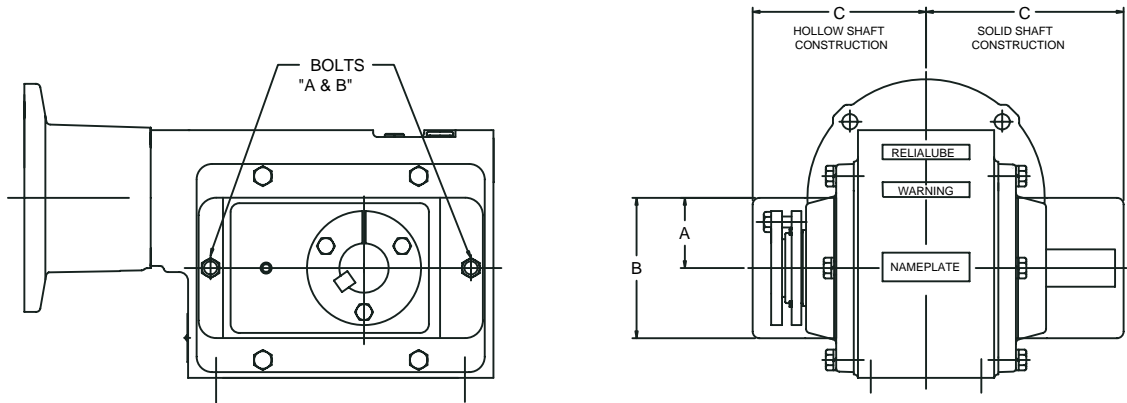

HOLLOW SHAFT CLOSED SHAFT GUARD KITS	
CASE SIZE	MODEL NO.
C150	6012052
C200	6012069
C262	6012076
C350	6012083

HOLLOW SHAFT			
CASE SIZE	A	B	C
C150	1.44	2.88	4.48
C200	2.00	4.00	4.94
C262	2.22	4.44	5.49
C350	2.37	4.75	6.58

HOLLOW SHAFT OPEN SHAFT GUARD KITS	
CASE SIZE	MODEL NO.
C150	6031046
C200	6031053
C262	6031060
C350	6031077

SOLID SHAFT CLOSED SHAFT GUARD KITS	
CASE SIZE	MODEL NO.
C150	6031633
C200	6031640
C262	6031657
C350	6031664

SOLID SHAFT			
CASE SIZE	A	B	C
C150	1.44	2.88	5.23
C200	2.00	4.00	5.94
C262	2.22	4.44	7.24
C350	2.37	4.75	9.83

FEATURES/BENEFITS PAGE G5-2	SPECIFICATION PAGE G5-4	NOMENCLATURE PAGE G5-5	RENEWAL PARTS PAGE G5-45
--------------------------------	----------------------------	---------------------------	-----------------------------



Combination TIGEAR SOLID SHAFT - SIZES C150-C350

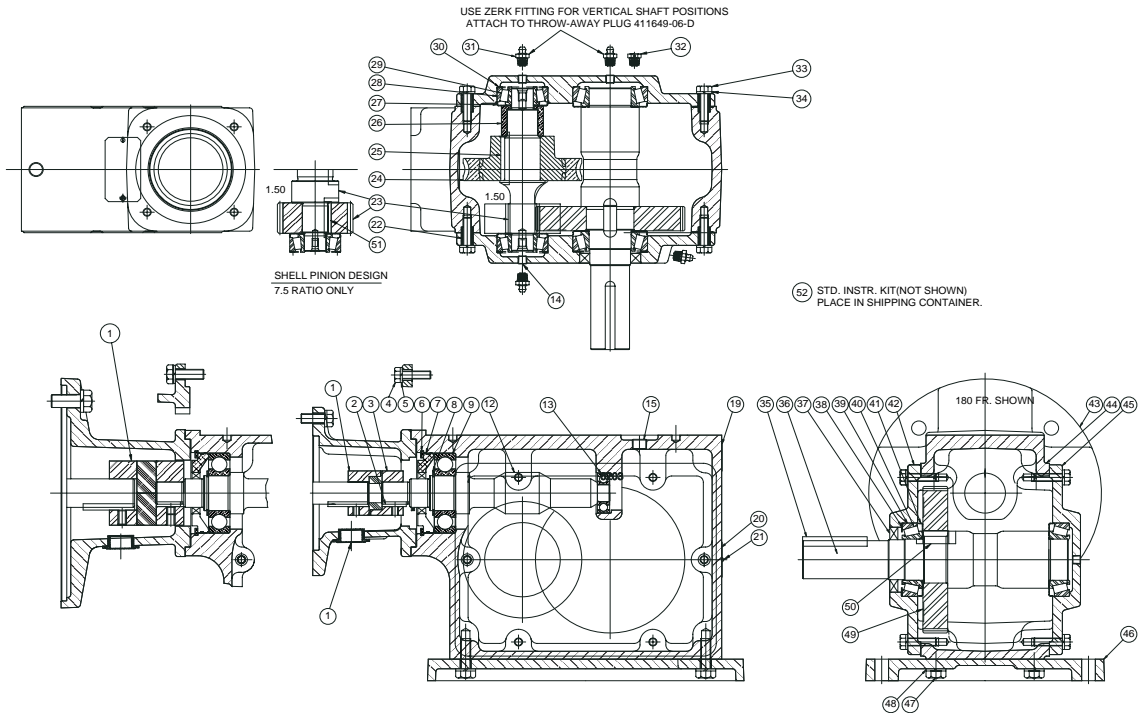

PART NUMBER LISTING						
ITEM	DESCRIPTION	QTY	C150	C200	C262	C350
1	CPLNG HUB (56C MTR)	0 - 1	278900	278900	278900	278900
	CPLNG HUB (140TC MTR)	0 - 1	278901	278901	278901	278901
	CPLNG HUB (180TC)	0 - 1	-----	60222209W	278907	278907
	CPLNG HUB (210TC)	0 - 1	-----	-----	-----	60222209B
	CPLNG ELEMENT 56/140	0 - 1	278911	278911	278911	278911
	CPLNG ELEMENT 180TC	0 - 1	-----	60222220A	60222211A	60222211A
2	KEY, INPUT SHAFT	1	276138	276138	276140	276140
3	CPLNG HUB, REDUCER 56/140	0 - 1	278900	276143	278901	278901
	CPLNG HUB, REDUCER 180	0 - 1	-----	276145	275806	275806
	CPLNG HUB, REDUCER 210	0 - 1	-----	-----	-----	60222209C
4	HEX HEAD SCREW	4	053202	053202	051929	051929
5	LOCKWASHER	4	50253	50253	050250	050250
6	CIRCLIP	1	278702	278702	278716	278146
*7	OIL SEAL ASSM	0 - 1	41162024A	41162024B	41162024C	41162024D
8	CIRCLIP	1	278710	278712	278715	278718
*9	BEARING, SEALED (1)	1	07914703E	07914703G	07914703N	07914703AA
12	WORM SHAFT	1	SEE GEAR CHART			
*13	BEARING	1	278883	07914702D	07914702K	07914702X
14	PIPE PLUG	1 - 3	41164738B	41164738B	41164738B	41164738B
15	PIPE PLUG	1	41164738A	41164738A	41164738A	41164738A

FEATURES/BENEFITS PAGE G5-2	SPECIFICATION PAGE G5-4	NOMENCLATURE PAGE G5-5	MODIFICATION/ACCESSORIES PAGE G5-34
--------------------------------	----------------------------	---------------------------	--

RENEWAL PARTS

**Combination TIGEAR
SOLID SHAFT - SIZES C150-C350**

PART NUMBER LISTING						
ITEM	DESCRIPTION	QTY	C150	C200	C262	C350
19	WARNING PLATE	1	60241524C	60241524C	60241524C	60241524C
20	NAMEPLATE	1	60200503C	60200503C	60200503C	60200503C
21	DRIVE SCREW	2	41163603B	41163603B	41163603B	41163603B
22	DOWEL PIN SLEEVE	4	41171506A	41171506A	41171506A	41171506B
23	INT PINION SHAFT	1	SEE GEAR CHART			
24	WORM GEAR	1	SEE GEAR CHART			
25	KEY	1	41168812V	41168812K	055610	050999
26	SPACER	1	41162210AA	41162210AB	41162210AE	41162210AD
*27	GREASE RETAINER	2	41162401A	41162401D	41162401B	41162401W
*28/29	BEARING ASSEMBLY	2	41162601D	41162601E	41162601B	41162601AC
30	SHIM	1	41164246D	41164250Z	41164246F	41164250AB
31	ZERK FITTING	0 - 2	07901913AW	07901938AW	07901913AW	07901938AW
32	PLUG, THROW-AWAY	0 - 2	41164906D	41164906D	41164906D	41164906D
33	HEX HEAD SCREW (4)	12	60245207H	60245207H	60245207H	60245207K
34	LOCKWASHER (4)	12	050253	050253	050253	304603
35	KEY	1	055592	055025	055060	41168812D
36	OUTPUT SHAFT	1	60242112A	60242113A	60242114A	60242115A
37	SEAL, OUTPUT	1	41162701FR	41162701FX	41162701FS	41162701FT
38	SHIM	1	41164250AC	41164246B	41164246AB	41164246H
*39/40	BEARING ASSEMBLY	2	41162601C	41162601A	41162601R	41162601AB
41	GREASE RETAINER	2	41162401C	41162401E	41162401R	41162401X
42	BEARING HSG, OPEN (3)*	1	07920624A	07920618B	08692302A	08692308A
43	"C" FACE ADPT 56/140	0 - 1	278574	278574	278476	278476
	"C" FACE ADPT 180 (2)	0 - 1	-----	07906722AB	278478	278478
	"C" FACE ADPT 210 (5)	0 - 1	-----	-----	-----	07906722AD
44	GEARCASE	1	08693202B	08693204B	08693206B	08693208B
45	BEARING HSG, CLOSED	1	07920628A	07920622B	08692306A	08693312A
46	BOLT ON FOOT	0 - 1	07914022A	07914020A	07914024A	07914026A
47	HEX HEAD SCREW	0 - 4	60245207A	60245207J	60245207J	60245207L
48	LOCKWASHER	0 - 4	050253	050684	304603	050469
49	HELICAL GEAR	1	SEE GEAR CHART			
50	GEAR KEY	1	41168812E	055087	055154	41168812AE
51	KEY, SHELL PINION RATIO 6.2 & 7.5	0 - 1	-----	-----		

*RECOMMENDED SPARE PARTS FOR MINIMUM PROTECTION

- (1) FOR A-5 MOUNTING ONLY USE SEALED BEARING 07914703F FOR C150, 07914703DD FOR C200, 07914703R FOR C262, 07914703BV FOR C350.
- (2) BOLT ON PLATE ADAPTOR ON SIZE C200. MUST ALSO USE 56/140 ADAPTOR.
- (3) SIZE C200 OUTPUT SHAFT UP USES 07920618C.
- (4) SIZE C350 USES 16 EACH.
- (5) ADD TO 180 C-ADPT FOR 210 MOTOR USE.



Combination TIGEAR STRAIGHT BORE - SIZES C150TS-C350S

(50) STD. INSTR. KIT(NOT SHOWN).
PLACE IN SHIPPING CONTAINER.

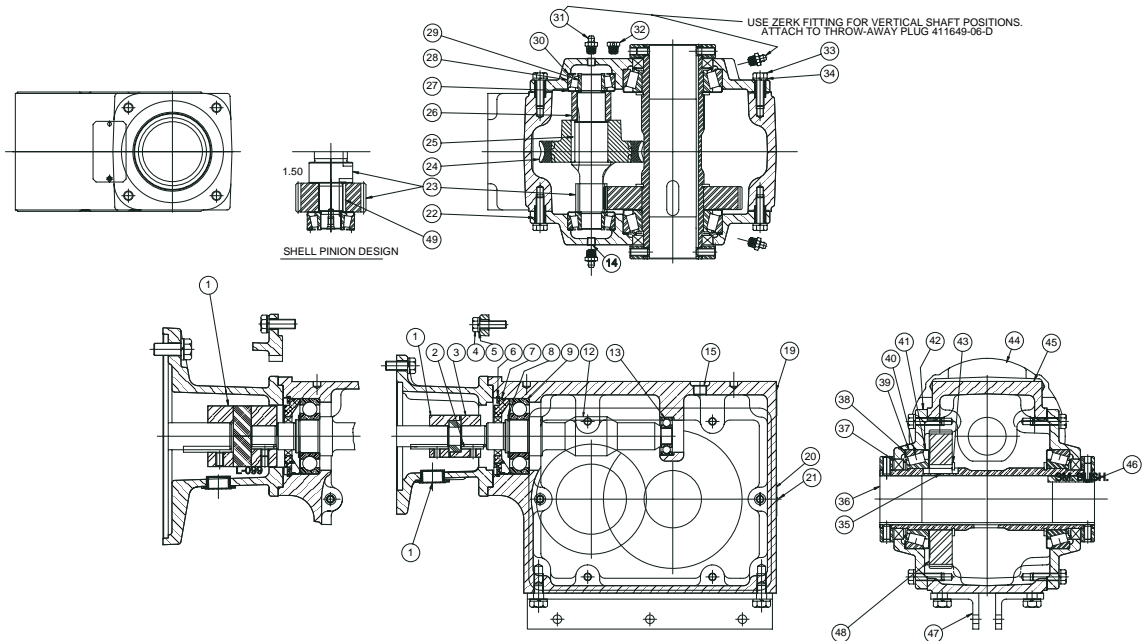

PART NUMBER LISTING						
ITEM	DESCRIPTION	QTY	C150	C200	C262	C350
1	CPLNG HUB (56C MTR)	0-1	278900	278900	278900	278900
	CPLNG HUB (140TC MTR)	0-1	278901	278901	278901	278901
	CPLNG HUB (180TC MOTOR)	0-1	----	60222209W	278907	278907
	CPLNG HUB (210TC)	0-1	----	----	----	60222209B
	CPLNG ELEMENT 56/140	0-1	278911	278911	278911	278911
	CPLNG ELEMENT 180/210TC	0-1	----	60222220A	60222211A	60222211A
2	KEY, INPUT SHAFT	1	276138	276138	276140	276140
3	CPLNG HUB, REDUCER W/ 56/140	0-1	278900	276143	278901	278901
	CPLNG HUB, REDUCER W/ 180TC	0-1	----	276145	275806	275806
	CPLNG HUB, REDUCER W/210TC	0-1	----	----	----	60222209C
4	HEX HEAD SCREW	4	053202	053202	051929	051929
5	LOCKWASHER	4	050253	050253	050250	050250
6	CIRCLIP	1	278702	278702	278716	276146
*7	OIL SEAL ASSM	1	41162024A	41162024B	41162024C	41162024D
8	CIRCLIP	1	278710	278712	278715	278718
*9	"BEARING, SEALED (1)"	1	07914703E	07914703G	07914703N	07914703AA
12	WORM SHAFT	1	SEE GEAR CHART			
*13	BEARING	1	278883	07914702D	07914702K	07914702X
14	PIPE PLUG	1-3	41164738B	41164738B	41164738B	41164738B
15	PIPE PLUG	1	41164738A	41164738A	41164738A	41164738A

FEATURES/BENEFITS PAGE G5-2	SPECIFICATION PAGE G5-4	NOMENCLATURE PAGE G5-5	MODIFICATION/ACCESSORIES PAGE G5-34
--------------------------------	----------------------------	---------------------------	--

RENEWAL PARTS



Combination TIGEAR

STRAIGHT BORE - SIZES C150TS-C350S

PART NUMBER LISTING						
ITEM	DESCRIPTION	QTY	C150	C200	C262	C350
19	WARNING PLATE	1	60241524C	60241524C	60241524C	60241524C
20	NAMEPLATE	1	60200503C	60200503C	60200503C	60200503C
21	NAMEPLATE PINS	2	41163603B	41163603B	41163603B	41163603B
22	SLEEVE DOWEL PIN	4	41171506A	41171506A	41171506A	41171506B
23	INT PINION SHAFT	1	SEE GEAR CHART			
24	WORM GEAR	1				
25	KEY	1	41168812V	41168812K	55610	50999
26	SPACER	1	41162210AA	41162210AB	41162210AE	41162210AD
27	GREASE RETAINER	2	41162401A	41162401D	41162401B	41162401W
*28/29	BEARING ASSEMBLY	2	41162601D	41162601E	41162601B	41162601AC
30	SHIM	1	41164246D	41164250Z	41164246F	41164250AB
31	ZERK FITTING	0-2	07901913AW	07901938AW	07901938AW	07901938AW
32	"PLUG, THROW-AWAY"	0-2	41164906D	41164906D	41164906D	41164906D
33	HEX HEAD SCREW (2)	12	60245207H	60245207H	60245207H	60245207K
34	LOCKWASHER (2)	12	050253	050253	050253	304603
35	KEY	1	41168812AA	41168812AB	41168812AC	41168812AD
36	OUTPUT SHAFT	1	07920702B	07920703B	07920704B	07920705B
*37	OUTPUT SEAL	2	41162701FS	41162701FT	41162701FV	41162701FW
38	SHIM	1	41164250AG	41164250AH	41164246H	41164250AK
*39/40	BEARING ASSEMBLY	2	41162601GP	41162601BR	41162601GR	41162601GS
41	GREASE RETAINER	1-2	41162401AB	41162401M	41162401AC	41162401AD
	GREASE RETAINER (6.2 & 7.5 RATIO)	0-1	41162336A	41162401AG	41162336B	41162336C
42	BEARING HOUSING, OPEN	2	07920626A	07920620B	08692304A	08693310A
43	RETAINING RING	2	41163708A	150182	41163702BH	41163708D
44	C-FACE ADAPTOR (56/140)	0-1	278574	278574	278476	278476
	C-FACE ADAPTOR (180)	0-1	-----	07906722AB	278478	278478
	ADAPTOR PLATE (210TC) (3)	0-1	-----	-----	-----	07906722AD
45	GEARCASE	1	08693202B	08693204B	08693206B	08693208B
46	STRAIGHT BORE BUSHING	2	SEE ACCESSORIES			
47	TORQUE ARM BRKT ASSM	0-1	60232807J	60232807C	60232807L	60232807R
47	TORQUE ARM ASSEMBLY	0-1	60232807H	60232807S	60232807M	60232807P
48	HELICAL GEAR	1	SEE GEAR CHART			
49	KEY, SHELL PINION RATIO 6.2 & 7.5	0-1	-----	-----	050994	055089

*RECOMMENDED SPARE PARTS FOR MINIMUM PROTECTION

(1) FOR A-5 MOUNTING ONLY USE SEALED BEARING 07914703F FOR C150, USE 07914703DD FOR C200, USE 07914703R FOR C262, USE 07914703BV FOR C350.

(2) SIZE C350 USE QTY 16.

(3) TO CONVERT UNIT TO 210TC INPUT THE 180TC ADAPTOR MUST ALSO BE USED.

RENEWAL PARTS



Combination TIGEAR TWIN TAPER BUSHING - SIZES C150T - C350T

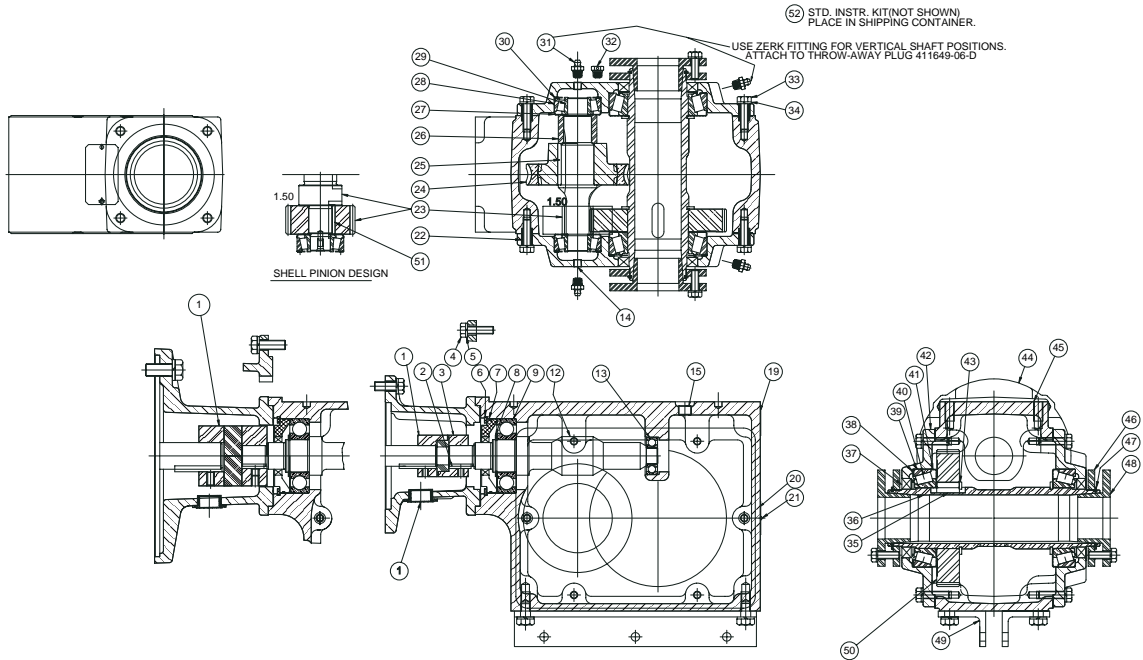

PART NUMBER LISTING						
ITEM	DESCRIPTION	QTY	C150	C200	C262	C350
1	CPLNG HUB (56C MTR)	0-1	278900	278900	278900	278900
	CPLNG HUB (140TC MTR)	0-1	278901	278901	278901	278901
	CPLNG HUB (180TC MOTOR)	0-1	----	60222209W	278907	278907
	CPLNG HUB (210TC)	0-1	----	----	----	60222209B
	CPLNG ELEMENT 56/140	0-1	278911	278911	278911	278911
	CPLNG ELEMENT 180/210TC	0-1	----	60222220A	60222211A	60222211A
2	KEY, INPUT SHAFT	1	276138	276138	276140	276140
3	CPLNG HUB, REDUCER W/ 56/140	0-1	278900	276143	278901	278901
	CPLNG HUB, REDUCER W/ 180TC	0-1	----	276145	275806	275806
	CPLNG HUB, REDUCER W/210TC	0-1	----	----	----	60222209C
4	HEX HEAD SCREW	4	053202	053202	051929	051929
5	LOCKWASHER	4	050253	050253	050250	050250
6	CIRCLIP	1	278702	278702	278716	278146
*7	OIL SEAL ASSM	1	41162024A	41162024B	41162024C	41162024D
8	CIRCLIP	1	278710	278712	278715	278718
*9	BEARING, SEALED (1)	1	07914703E	07914703G	07914703N	07914703AA
12	WORM SHAFT	1	SEE GEAR CHART			
*13	BEARING	1	278883	07914702D	07914702K	07914702X
14	PIPE PLUG	1-3	41164738B	41164738B	41164738B	41164738B
15	PIPE PLUG	1	41164738A	41164738A	41164738A	41164738A

FEATURES/BENEFITS PAGE G5-2	SPECIFICATION PAGE G5-4	NOMENCLATURE PAGE G5-5	MODIFICATION/ACCESSORIES PAGE G5-34
--------------------------------	----------------------------	---------------------------	--

RENEWAL PARTS



Combination TIGEAR TWIN TAPER BUSHING - SIZES C150T - C350T

PART NUMBER LISTING						
ITEM	DESCRIPTION	QTY	C150	C200	C262	C350
19	WARNING PLATE	1	60241524C	60241524C	60241524C	60241524C
20	NAMEPLATE	1	60200503C	60200503C	60200503C	60200503C
21	NAMEPLATE PINS	2	41163603B	41163603B	41163603B	41163603B
22	SLEEVE DOWEL PIN	4	41171506A	41171506A	41171506A	41171506B
23	INT PINION SHAFT	1	SEE GEAR CHART			
24	WORM GEAR	1				
25	KEY	1	41168812V	41168812K	55610	50999
26	SPACER	1	41162210AA	41162210AB	41162210AE	41162210AD
27	GREASE RETAINER	2	41162401A	41162401D	41162401B	41162401W
*28/29	BEARING ASSEMBLY	2	41162601D	41162601E	41162601B	41162601AC
30	SHIM	1	41164246D	41164250Z	41164246F	41164250AB
31	ZERK FITTING	0-2	07901913AW	07901938AW	07901938AW	07901938AW
32	PLUG, THROW-AWAY	0-2	41164906D	41164906D	41164906D	41164906D
33	HEX HEAD SCREW (2)	12	60245207H	60245207H	60245207H	60245207K
34	LOCKWASHER (2)	12	050253	050253	050253	304603
35	KEY	1	41168812AA	41168812AB	41168812AC	41168812AD
36	OUTPUT SHAFT	1	07920702C	07920703C	07920704C	07920705C
*37	OUTPUT SEAL	2	41162701FS	41162701FT	41162701FV	41162701FW
38	SHIM	1	41164250AG	41164250AH	41164246H	41164250AK
*39/40	BEARING ASSEMBLY	2	41162601GP	41162601BR	41162601GR	41162601GS
41	GREASE RETAINER	1-2	41162401AB	41162401M	41162401AC	41162401AD
	GREASE RETAINER (6.2 & 7.5 RATIO)	0-1	41162336A	41162401AG	41162336B	41162336C
42	BEARING HOUSING, OPEN	2	07920626A	07920620B	08692304A	08693310A
43	RETAINING RING	2	41163708A	150182	41163702BH	41163708D
44	C-FACE ADAPTOR (56/140)	0-1	278574	278574	278476	278476
	C-FACE ADAPTOR (180)	0-1	----	07906722AB	278478	278478
	ADAPTOR PLATE (210TC) (3)	0-1	----	----	----	07906722AD
45	GEARCASE	1	08693202B	08693204B	08693206B	08693208B
46	BACKING PLATE	2	41162518A	241383	242392	243115
47	SPIRAL LOCKRING	2	41163706F	421111	421112	41163706E
48	TWIN TAPER BUSHING KIT	1	SEE ACCESSORIES			
49	TORQUE ARM BRKT ASSM	0-1	60232807J	60232807C	60232807L	60232807R
	BRKT HARDWARE ASSM	0-1	60232807H	60232807S	60232807M	60232807P
50	HELICAL GEAR	1	SEE GEAR CHART			
51	KEY, SHELL PINION RATIO 6.2 & 7.5	1	----	----	050994	055089

*RECOMMENDED SPARE PARTS FOR MINIMUM PROTECTION

(1) FOR A-5 MOUNTING ONLY USE SEALED BEARING 07914703F FOR C150, USE 07914703DD FOR C200, USE 07914703R FOR C262, USE 07914703BV FOR C350.

(2) SIZE C350 USES QTY 16.

(3) TO CONVERT UNIT TO 210TC INPUT THE 180TC ADAPTOR MUST ALSO BE USED.

FEATURES/BENEFITS PAGE G5-2	SPECIFICATION PAGE G5-4	NOMENCLATURE PAGE G5-5	MODIFICATION/ACCESSORIES PAGE G5-34
--------------------------------	----------------------------	---------------------------	--



Combination TIGEAR SOLID AND HOLLOW SHAFT OUTPUT

SIZE C150

TOTAL RATIO	1st Stage		2nd Stage		
	Worm Shaft	Worm Gear	Solid Shaft		Hollow Shaft
			Pinion	Output Gear	Output Gear
7.5	276068	60241102	07915819B	07915613B	07915613K
9.4	276068	60241102	07915819C	07915613C	07915613L
10	276068	60241102	07915819D	07915613D	07915613M
15	276068	60241102	07915819E	07915613E	07915613N
18	276068	60241102	07915819F	07915613F	07915613P
20	276068	60241102	07915819G	07915613G	07915613R
25	276068	60241102	07915819H	07915613H	07915613S
30	276069	60240821	07915819G	07915613G	07915613R
33.3	276070	60241163	07915819F	07915613F	07915613P
38	276069	60240821	07915819H	07915613H	07915613S
40	276070	60241163	07915819H	07915613G	07915613R
50	276070	60241163	07915819H	07915613H	07915613S
60	276072	60240828	07915819G	07915613G	07915613R
75	276072	60240828	07915819H	07915613H	07915613S
80	276074	60241164	07915819G	07915613G	07915613R
90	276073	60241171	07915819H	07915613H	07915613S
100	276074	60241164	07915819H	07915613H	07915613S
125	276076	60241165	07915819G	07915613G	07915613R
150	276076	60241165	07915819H	07915613H	07915613S
160	276077	60241166	07915819G	07915613G	07915613R
200	276077	60241166	07915819H	07915613H	07915613S
240	276079	60241168	07915819G	07915613G	07915613R
300	276079	60241168	07915819H	07915613H	07915613S

SIZE C200

TOTAL RATIO	1st Stage		2nd Stage		
	Worm Shaft	Worm Gear	Solid Shaft		Hollow Shaft
			Pinion	Output Gear	Output Gear
9.42	276090	60241202	07915820C	07915614C	07915614M
10	276090	60241202	07915820D	07915614D	07915614L
15	276090	60241202	07915820E	07915614E	07915614N
16.96	276091	60241204	07915820G	07915614G	07915614M
18	276090	60241202	07915820F	07915614F	07915614P
18.85	276092	60241205	07915820C	07915614C	07915614L
20	276090	60241202	07915820G	07915614G	07915614R
25	276090	60241202	07915820H	07915614H	07915614S
30	276091	60241204	07915820G	07915614G	07915614R
38	276091	60241204	07915820H	07915614H	07915614S
40	276092	60241205	07915820G	07915614G	07915614R
50	276092	60241205	07915820H	07915614H	07915614S
60	276094	60241207	07915820G	07915614G	07915614R
75	276094	60241207	07915820H	07915614H	07915614S
80	276096	60241209	07915820G	07915614G	07915614R
90	276095	60241208	07915820H	07915614H	07915614S
100	276096	60241209	07915820H	07915614H	07915614S
125	276097	60241210	07915820H	07915614H	07915614S
150	276098	60241211	07915820H	07915614H	07915614S
160	276099	60241213	07915820G	07915614G	07915614R
200	276099	60241213	07915820H	07915614H	07915614S
240	276101	60241215	07915820G	07915614G	07915614R
300	276101	60241215	07915820H	07915614H	07915614S

SIZE C262

TOTAL RATIO	1st Stage		2nd Stage		
	Worm Shaft	Worm Gear	Solid Shaft		Hollow Shaft
			Pinion	Output Gear	Output Gear
7.5 (1)	276102	60241302	07915821B	07915615B	07915615K
9.4	276102	60241302	07915821M	07915615C	07915615L
10	276102	60241302	07915821N	07915615D	07915615M
14.1	276103	60241304	07915821M	07915615C	07915615L
15	276102	60241302	07915821P	07915615E	07915615N
17.04	276103	60241304	07915821N	07915615D	07915615M
18	276102	60241302	07915821R	07915615F	07915615P
20	276102	60241302	07915821S	07915615G	07915615R
22.73	276104	60241305	07915821N	07915615D	07915615M
25	276102	60241302	07915821T	07915615H	07915615S
27.92	276104	60241305	07915821P	07915615E	07915615N
30	276103	60241304	07915821S	07915615G	07915615R
33.3	276104	60241305	07915821R	07915615F	07915615P
38	276103	60241304	07915821T	07915615H	07915615S
40	276104	60241305	07915821S	07915615G	07915615R
42.23	276106	60241307	07915821P	-----	07915615N
50	276104	60241305	07915821T	07915615H	07915615S
60	276106	60241307	07915821S	07915615G	07915615R
75	276106	60241307	07915821T	07915615H	07915615S
80	276109	60203712	07915821R	07915615F	07915615P
90	276111	60241311	07915821N	07915615D	07915615M
100	276110	60241313	07915821R	07915615F	07915615P
125	276110	60241311	07915821S	07915615G	07915615R
150	376110	60241311	07915821T	07915615H	07915615S
160	276111	60241313	07915821S	07915615G	07915615R
200	276111	60241313	07915821T	07915615H	07915615S
240	276113	60241315	07915821S	07915615G	07915615R
300	276113	60241315	07915821T	07915615H	07915615S

SIZE C350

TOTAL RATIO	1st Stage		2nd Stage		
	Worm Shaft	Worm Gear	Solid Shaft		Hollow Shaft
			Pinion	Output Gear	Output Gear
6.2 (1)	276114	60207767	07915822A	07915616A	07915616J
7.5 (1)	276114	60207767	07915822B	07915616B	07915616K
9.4	276114	60207767	07915822C	07915616C	07915616L
10	276114	60207767	07915822D	07915616D	07915616M
15	276114	60207767	07915822E	07915616E	07915616N
18	276114	60207767	07915822F	07915616F	07915616P
20	276114	60207767	07915822G	07915616G	07915616R
22.61	276116	60242403	07915822D	07915616D	07915616M
25	276114	60207767	07915822H	07915616H	07915616S
30	276115	60207763	07915822G	07915616G	07915616R
33.3	276116	60242403	07915822F	07915616F	07915616P
38	276115	60207763	07915822H	07915616H	07915616S
40	276115	60242403	07915822G	07915616G	07915616R
47.12	276121	275593	07915822C	07915616C	07915616L
50	276116	60242403	07915822H	07915616H	07915616S
60	276118	60242404	07915822G	07915616G	07915616R
64.19	276117	60207708	07915822H	07915616H	07915616S
75	276118	60242404	07915822H	07915616H	07915616S
80	276120	60242405	07915822G	07915616G	07915616R
86	276121	275593	07915822F	07915616F	07915616P
100	276120	60242405	07915822H	07915616H	07915616S
125	276121	275593	07915822H	07915616H	07915616S
150	276122	275594	07915822G	07915616G	07915616R
160	276123	60242407	07915822G	07915616G	07915616R
200	276123	60242407	07915822H	07915616H	07915616S
240	276125	275595	07915822G	07915616G	07915616R
300	276125	275595	07915822H	07915616H	07915616S

(1) SHELL PINION RATIO. ALSO ORDER PINION SHAFT 07915821U AND KEY 50994.

(1) SHELL PINION RATIO. ALSO ORDER PINION SHAFT 07915821J AND KEY 55089.

FEATURES/BENEFITS PAGE G5-2	SPECIFICATION PAGE G5-4	NOMENCLATURE PAGE G5-5	MODIFICATION/ACCESSORIES PAGE G5-34
--------------------------------	----------------------------	---------------------------	--

ENGINEERING/ TECHNICAL



Combination TIGEAR

INSTALLATION

Combination TIGEAR reducers can be installed by either using the drilled and tapped holes in the bottom of the gearcase or by attaching a bolt-on foot kit. The mounting surface must be flat or breakage may result when mounting bolts are tightened. Use steel shims as required to assure that the gearbox is sitting solidly on all four bolting points and is properly aligned.

On hollow shaft units the ideal position of the tie rod arm is at right angles to a line between the point of attachment of the torque arm to the reducer and the centerline of the output shaft. This angle may vary up to 30° in either direction. CAUTION: Exceeding the 30° variance of the tie rod could result in excessive reaction load and equipment damage. It is good practice to position the rod assembly such that it will be loaded in tension during operation of the reducer. Viewing the output shaft from the K-1 mounting position, a clockwise rotation of the input shaft will cause a clockwise rotation of the reducer about the output shaft. Proper positioning of the tie rod assembly will prevent the components from being loaded in compression.

LUBRICATION

The DODGE Combination TIGEAR reducer incorporates the unique RELIALUBE system which eliminates the lengthy preparation normally required to put a reducer into service. TIGEAR Combination reducers are factory filled with Mobil SHC634 for S-1, K-1, and L-1 mounting positions. Any approved mounting position may be specified upon order entry and additional lube, if required, will be added at no additional charge. S2, S4, K2, K4, L2 and L4 mounting positions also require the addition of grease fittings for upper bearing lubrication and will be included at no additional charge if ordered through factory. Note: Failure to follow these instructions will void warranty.

The chart below provides two methods for verifying the reducer has the correct amount of oil. The oil can be measured by volume or by checking dimension "A". Dimension "A" is measured with a dipstick inserted into the tapped fill hole from the machined top of the gearcase to the oil level with the gearbox set level on the ground.

Hollow (Tapered Or Straight Bore) Output Shaft								
Size	Assm.							
	S1 H4 B2	DIST. "A" Inches	S2 H1 B3	"A"	S4 H3 B1	A	S5 H5 B5	"A"
C150	21 oz.	3-1/4"	27 oz.	2-1/4"	27 oz.	2-1/4"	43 oz.	1-1/2"
C200	32 oz.	4-1/4"	44 oz.	3-1/4"	44 oz.	3-1/4"	60 oz.	2-1/8"
C262	52 oz.	6-1/8"	112 oz.	2-3/4"	112 oz.	2-3/4"	112 oz.	2-3/4"
C350	136 oz.	7-1/2"	235 oz.	4"	235 oz.	4"	256 oz.	3-3/8"

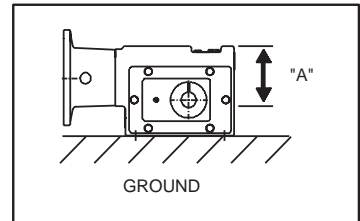

Solid Output Shaft								
Size	Assm							
	L1 K1 B2 H4	Dist. "A" Inches	L4 K2 B1 H1	"A"	K4 L2 B3 H3	"A"	L5 K5 B5 H5	"A"
C150	21 oz.	3-1/4"	32 oz.	1-3/4"	44 oz.	3/4"-1/2"	44 oz.	3/4"
C200	32 oz.	4-1/4"	44 oz.	3"	68 oz.	1-3/4"	68 oz.	1-1/2"
C262	52 oz.	6-1/8"	96 oz.	3-3/8"	128 oz.	1-1/2"	128 oz.	1-3/4"
C350	136 oz.	7-1/2"	235 oz.	4-1/2"	312 oz.		256 oz.	4"

As an example, customer field conversion to S5, K5 and L5 can be accomplished by increasing the oil volume from the factory volumes to the levels shown. As C350 S1 filled with

136 oz. requires an additional 120 oz. for a S5 mounting position.

FEATURES/BENEFITS PAGE G5-2	SPECIFICATION PAGE G5-4	NOMENCLATURE PAGE G5-5	MODIFICATION/ACCESSORIES PAGE G5-34
--------------------------------	----------------------------	---------------------------	--



Combination TIGEAR LUBRICANT OPTIONS

FOOD GRADE LUBRICANT

Chevron FM460X lubricant serves the needs of food processing applications which need a non-contaminating gear oil. Chevron FM460X carries USDA Class AA and H1 approvals. Use of this lubricant can reduce the potential damage to food caused by oil seeping through worn-out shaft seals.

LOW TEMPERATURE LUBRICANT

The standard lubricant provided with TIGEAR reducers covers an operating ambient temperature range from -10° F to +100° F. For ambient operating conditions above +100° F contact DODGE Application Engineering. To apply TIGEAR reducers in applications from -10°o F to -30° F, specify Mobil SHC-629 lubricant.



LOW TEMPERATURE	
Volume	Part Number (SHC-629)
1 qt.	41170966AG
1 gal.	41170966AH

STANDARD	
Volume	Part Number (SHC-634)
12 oz.	41170966AB
1 qt.	41170966AE
1 gal.	41170966AF

FEATURES/BENEFITS PAGE G5-2	SPECIFICATION PAGE G5-4	NOMENCLATURE PAGE G5-5	MODIFICATION/ACCESSORIES PAGE G5-34
--------------------------------	----------------------------	---------------------------	--



Combination TIGEAR

MOUNTING POSITIONS - HOLLOW OUTPUT SHAFT

For applications requiring the addition of lubricant, Mobil SHC 634 is available. See G5-53.

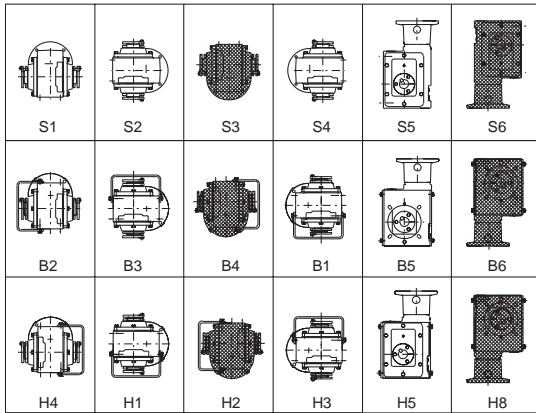

Mounting Positions - Solid Output Shaft

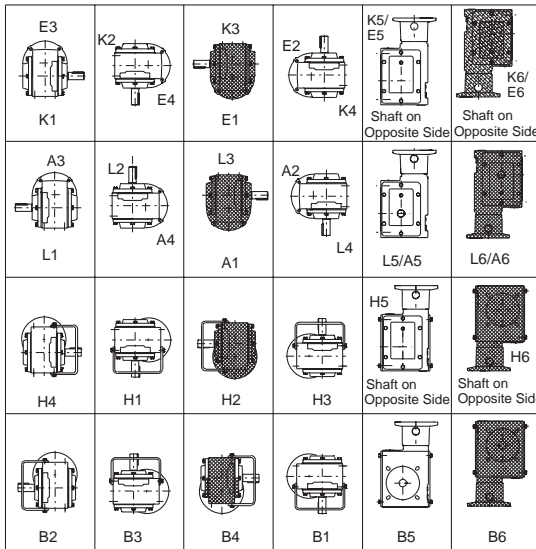

NOTE: Shaded units indicate mounting positions not recommended. Use of product in positions not recommended negates time-in-use warranty.

Figure 1

MAINTENANCE

The Combination TIGEAR reducer requires no periodic maintenance. However, DODGE recommends occasional visual inspections to check for hardware security, leakage, and general overall condition. In extremely dirty environments, heavy accumulation of dirt can cause overheating. An occasional wash down or wipe-off will assure the long life of the equipment.

APPLICATION

The Combination TIGEAR reducer is designed to operate within the following temperature limits:

Ambient-10° to 165°F

Oil Sump-10° to 200°F

When ambient temperatures exceed 100°F, care should be taken not to exceed a 200°F sump temperature during unit operation. These conditions could require the application of a larger reducer. Units which operate in ambient temperatures below -10°F may be accommodated on factory orders by lower viscosity Mobil SHC 600 series products.

The continuous rated input horsepower shown on the reducer nameplate is for a service factor of 1.0 at an input speed of 1750 rpm. Before placing the reducer into service, check the nameplate to confirm that its horsepower rating is consistent with the motor horsepower and desired service factor.

On hollow shaft units, consideration should be given to the design of the driven shaft on which the reducer is mounted. Shafting material and size should be capable of carrying loads from the reducer weight, transmitted torque, and tie rod reaction force.

FEATURES/BENEFITS PAGE G5-2	SPECIFICATION PAGE G5-4	NOMENCLATURE PAGE G5-5	MODIFICATION/ACCESSORIES PAGE G5-34
--------------------------------	----------------------------	---------------------------	--



Combination TIGEAR

EXACT RATIOS SOLID SHAFT REDUCERS

NOMINAL RATIO	GEARCASE SIZE			
	C150	C200	C262	C350
6.1	-	-	-	6.030
7.5	7.335	-	7.414	7.500
9.4	9.231	9.423	9.400	9.423
10	11.087	11.304	11.304	11.304
15	13.958	13.958	13.958	13.958
18	16.667	16.667	16.667	16.667
20	20.278	20.278	20.278	20.278
25	25.333	25.333	25.333	25.333
30	30.417	30.417	30.417	30.417
38	38.000	38.000	38.000	38.000
40	40.556	40.556	40.556	40.556
50	50.667	50.667	50.667	50.667
60	60.833	60.833	60.833	60.833
75	76.000	76.000	76.000	76.000
80	81.111	81.111	81.111	81.111
86	-	-	-	83.333
90	91.200	91.200	91.200	-
100	101.333	101.333	101.333	101.333
125	121.667	126.667	126.667	126.667
150	152.000	152.000	152.000	152.000
160	162.222	162.222	162.222	162.222
200	202.667	202.667	202.667	202.667
240	243.333	243.333	243.333	243.333
300	304.000	304.000	304.000	304.000

EXACT RATIO HOLLOW SHAFT REDUCERS

NOMINAL RATIO	GEARCASE SIZE			
	C150	C200	C262	C350
6.1	-	-	-	6.030
7.5	7.335	-	7.414	7.500
9.4	9.231	9.423	9.400	9.423
10	11.087	11.304	11.364	11.304
15	13.958	13.958	13.958	13.958
18	16.667	16.667	16.667	16.667
20	20.278	20.278	20.278	20.278
25	25.333	25.333	25.333	25.333
30	30.417	30.417	30.417	30.417
38	38.000	38.000	38.000	38.000
40	40.556	40.556	40.556	40.556
50	50.667	50.667	50.667	50.667
60	60.833	60.833	60.833	60.833
75	76.000	76.000	76.000	76.000
80	81.111	81.111	83.751	81.111
86	-	-	-	83.333
90	91.200	91.200	90.908	-
100	101.333	101.333	99.999	101.333
125	121.667	126.667	121.667	126.667
150	152.000	152.000	152.000	152.000
160	162.222	162.222	162.222	162.222
200	202.667	202.667	202.667	202.667
240	243.333	243.333	243.333	243.333
300	304.000	304.000	304.000	304.000

FEATURES/BENEFITS PAGE G5-2	SPECIFICATION PAGE G5-4	NOMENCLATURE PAGE G5-5	MODIFICATION/ACCESSORIES PAGE G5-34
--------------------------------	----------------------------	---------------------------	--



Combination TIGEAR

ROTATIONAL INERTIA SUMMARY

All values are lb-in² referred to input shaft

Solid Output Units

Nominal Ratio	C150			C200			C262		C350	
	56/140 Fr.	56/140 Fr.	180 Fr.	56/140 Fr.	180 Fr.	56/140 Fr.	180 Fr.	56/140 Fr.	180 Fr.	
10	0.605	0.953	1.460	2.510	4.170	10.190	11.850			
15	0.599	0.938	1.440	2.460	4.120	10.040	11.700			
18	0.598	0.928	1.430	2.440	4.100	9.960	11.620			
20	0.591	0.920	1.420	2.410	4.070	9.880	11.540			
25	0.588	0.912	1.410	2.390	4.050	9.810	11.470			
30	0.529	0.761	1.260	1.960	3.620	7.170	8.830			
38	0.528	0.757	1.260	1.950	3.610	7.140	8.800			
40	0.520	0.740	1.240	1.870	3.530	6.630	8.290			
50	0.520	0.739	1.240	1.870	3.530	6.610	8.270			
60	0.512	0.718	1.220	1.770	3.430	5.300	6.960			
75	0.512	0.718	1.220	1.770	3.430	5.370	7.030			
80	0.512	0.720	1.220	1.610	3.270	5.270	6.930			
90	0.501	0.795	1.300	1.610	3.270	5.360	7.020			
100	0.511	0.719	1.220	1.600	3.260	5.270	6.930			
125	0.518	0.705	1.210	1.600	3.260	5.040	6.700			
150	0.518	0.744	1.250	1.680	3.340	4.910	6.570			
160	0.509	0.713	1.220	1.740	3.400	5.130	6.790			
200	0.509	0.713	1.220	1.740	3.400	5.130	6.790			
240	0.505	0.694	1.200	1.670	3.330	4.850	6.510			
300	0.505	0.694	1.200	1.670	3.330	4.850	6.510			

Hollow Output Units

Nominal Ratio	C150			C200			C262		C350	
	56/140 Fr.	56/140 Fr.	180 Fr.	56/140 Fr.	180 Fr.	56/140 Fr.	180 Fr.	56/140 Fr.	180 Fr.	
10	0.611	0.984	1.490	2.540	4.200	10.220	11.880			
15	0.602	0.958	1.460	2.480	4.140	10.060	11.720			
18	0.600	0.942	1.440	2.450	4.110	9.970	11.630			
20	0.593	0.929	1.430	2.420	4.080	9.890	11.550			
25	0.590	0.918	1.420	2.400	4.060	9.820	11.480			
30	0.530	0.765	1.270	1.960	3.620	7.180	8.840			
38	0.528	0.760	1.260	1.950	3.610	7.140	8.800			
40	0.521	0.743	1.240	1.870	3.530	6.630	8.290			
50	0.520	0.740	1.240	1.870	3.530	6.610	8.270			
60	0.512	0.720	1.220	1.770	3.430	5.300	6.960			
75	0.512	0.718	1.220	1.770	3.430	5.370	7.030			
80	0.512	0.720	1.220	1.610	3.270	5.270	6.930			
90	0.501	0.795	1.300	1.610	3.270	5.360	7.020			
100	0.511	0.720	1.220	1.600	3.260	5.270	6.930			
125	0.518	0.706	1.210	1.600	3.260	5.040	6.700			
150	0.518	0.744	1.250	1.680	3.340	4.910	6.570			
160	0.509	0.713	1.220	1.740	3.400	5.130	6.790			
200	0.509	0.713	1.220	1.740	3.400	5.130	6.790			
240	0.505	0.694	1.200	1.670	3.330	4.850	6.510			
300	0.505	0.694	1.200	1.670	3.330	4.850	6.510			

FEATURES/BENEFITS PAGE G5-2	SPECIFICATION PAGE G5-4	NOMENCLATURE PAGE G5-5	MODIFICATION/ACCESSORIES PAGE G5-34
--------------------------------	----------------------------	---------------------------	--

ENGINEERING/TECHNICAL

BEARING ENGINEERING SECTION

Vibration Frequencies of Anti-Friction Mounted Bearings	G6-2
Bearing Life Adjustment Factors	G6-9
(Rolling Element Bearings)	

PT COMPONENT ENGINEERING SECTION

V-Belt Sheave Groove Dimensions	G6-11
Conveyor Belt FPM to RPM	G6-12
Material Characteristics	G6-13

GENERAL ENGINEERING SECTION

Shafting	G6-15
Expansion of Shafting	G6-20
Weights/Properties of Steel Shafting	G6-21
Oil Viscosity Classification	G6-23
English Standard Measurement	G6-24
Metric Standard Measurement & Conversion	G6-26
Common Conversion Factors	G6-27
Flywheel Formulas	G6-34
Centrifugal Force	G6-34
Formulas and Constants	G6-33
Torque and Horsepower Equivalents	G6-35
Overhung Loads	G6-35
Mathematical Equations	G6-35
Strength and Physical Properties of Various Metals	G6-36
Properties of Sections	G6-37
Coefficients of Friction (f)	G6-38
Hardness Comparison	G6-38
U.S. Standard Sheet Metal Gages	G6-38
Trigonometric Formula	G6-39
Part Number Index	INDEX-1
Keyword Index	INDEX-27

Vibration Frequencies Of DODGE Anti-Friction Mounted Bearings

More and more manufacturing facilities are getting involved with plant-wide preventive maintenance programs. By monitoring vibration levels of motors, pumps, fans and compressors, maintenance supervisors can predict imminent failures. Knowing that a piece of equipment is showing signs of potential failure permits scheduling of maintenance at an appropriate time and avoids the consequences of catastrophic failures. Shown on Table 1 - Table 10 are vibration frequencies generated by bearing components defects. All frequencies are based on unity inner ring or cone rotation.

How to Use the Tables

If a 2-7/16 Type E pillow block is rotating at 1000 RPM, the vibration due to a failed component will show up at the following frequencies: (Table 3 , Line 6)

Frequency

Cup Nick or Spall	1000 x 9.249 = 9249 RPM
Cone Nick or Spall	1000 x 11.751 = 11751 RPM
Roller Nick or Spall	1000 x 8.068 = 8068 RPM
Roll Size Variation	1000 x .440 = 440 RPM

Since all the values on Table 1 - Table 10 are based on unity inner ring or cone rotation, the vibration due to flaws will show up at the frequencies obtained by multiplying the RPM times the factors found on the appropriate table. The resulting product will have units of REV./MIN.

Table 1: All Setscrew, Eccentric & D-Lok Ball Bearing Parameters For Vibration Analysis (1-RPS)

Series	SC Bore	SCM Bore	# Balls	Diameter of Balls	Pitch Diameter	Outer Ring Frequency Hz	Inner Ring Frequency Hz	Ball Spin Frequency Hz	Cage Frequency Hz
203	1/2 - 5/8		8	17/64	1.1506	3.076569	4.923431	2.050406	0.384571
204	1/2 - 3/4		8	5/16	1.3251	3.056675	4.943325	2.002244	0.382084
205	7/8 - 1		9	5/16	1.5325	3.582382	5.417618	2.350042	0.398042
206	1-1/6 - 1-1/4	1	9	3/8	1.823	3.574328	5.425672	2.327814	0.397148
207	1-1/4 - 1-7/16	1-3/16	9	7/16	2.136	3.578301	5.421699	2.338732	0.397589
208	1-1/2 - 1-5/8	1-7/16 - 1-1/2	9	1/2	2.387	3.557394	5.442606	2.282266	0.395266
209	1-11/16 - 1-3/4	1-1/2	9	13/25	2.5591	3.585616	5.414384	2.359075	0.398402
210	1-15/16 - 2	1-11/16 - 1-3/4	10	1/2	2.7645	4.095677	5.904323	2.674068	0.409568
211	2 2-1/4	1-15/16 - 2	10	9/16	3.092	4.090395	5.909605	2.657484	0.409039
212	2-1/4 - 2-7/16	2-3/16 - 2-1/4	10	5/8	3.385	4.076809	5.923191	2.615681	0.407681
214	2-11/16	2-7/16 - 2-1/2	10	11/16	3.775	4.089404	5.910596	2.654395	0.408940
215	2-15/16	2-11/16	11	11/16	4.085	4.574357	6.425643	2.886760	0.415851
216		2-15/16 - 3	11	3/4	4.33	4.547344	6.452656	2.800062	0.413395
218		3-7/16 - 3-1/2	11	27/32	4.9199	4.556764	6.443236	2.829748	0.414251

Table 2: CC Ball Bearing Parameters For Vibration Analysis (1-RPS)

Series	Shaft Size	# Balls	Diameter of Balls	Pitch Diameter	Outer Ring Frequency Hz	Inner Ring Frequency Hz	Ball Spin Frequency Hz	Cage Frequency Hz
205	15/16 - 1	9	5/16	1.516	3.572394	5.427606	2.322533	0.396933
206	1-1/8 - 1-3/16	9	3/8	1.811	3.568194	5.431806	2.311133	0.396466
207	1-1/4 - 1-7/16	9	7/16	2.106	3.565171	5.434829	2.302987	0.396130
209	1-11/16 - 1-3/4	9	1/2	2.362	3.547417	5.452583	2.256157	0.394157
210	1-15/16	10	1/2	2.756	4.092888	5.907112	2.665289	0.409289
211	2-3/16	10	9/16	3.051	4.078171	5.921829	2.619817	0.407817

Table 3: Type E, K, DI, and TAF Tapered Roller Bearing Parameters For Vibration Analysis (1-RPS)

Bore Size	# Rollers Per Row	Mean Diameter of Rollers	Pitch Diameter	Contact Angle	Cup Frequency Hz	Cone Frequency Hz	Roller Spin Frequency Hz	Cage Frequency Hz
1-3/16 - 1-1/4	19	0.23	1.774	17.533	8.325540	10.674460	3.797580	0.438186
1-3/8 - 1-7/16	20	0.29	2.084	16.5	8.665750	11.334250	3.529138	0.433287
1-1/2 - 1-11/16	18	0.35	2.411	16	7.744100	10.255900	3.377216	0.430228
1-3/4 - 2	17	0.41	2.709	12.033	7.241814	9.758186	3.231274	0.425989
2-3/16	19	0.41	3.014	13.283	8.242270	10.757730	3.611184	0.433804
2-1/4 - 2-1/2	21	0.41	3.337	14.5	9.251011	11.748989	4.011931	0.440524
2-11/16 - 3	24	0.41	3.9	16.733	10.791879	13.208121	4.707891	0.449662
3-3/16 - 3-1/2	26	0.46	4.78	18.167	11.811316	14.188684	5.152213	0.454281
3-15/16 - 4	26	0.51	5.12	17.567	11.765467	14.234533	4.974340	0.452518
4-7/16 - 4-1/2	25	0.59	5.727	18.983	11.282275	13.717725	4.807330	0.451291
4-15/16 - 5	25	0.68	6.568	17	11.262395	13.737605	4.782071	0.450496
5-7/16 - 6	32	0.67	8.444	17.75	14.790895	17.209105	6.265507	0.462215
6-7/16 - 7	27	0.93	9.791	19.167	12.288783	14.711217	5.221605	0.455140

$$\text{Cup Frequency} = N * \text{RPM} * (1 - (\text{Bd} * \cos a / \text{Pd})) / 2$$

$$\text{Cone Frequency} = N * \text{RPM} * (1 + (\text{Bd} * \cos a / \text{Pd})) / 2$$

$$\text{Roller Spin Frequency} = \text{Pd} * \text{RPM} * (1 - (\text{Bd} * \cos a / \text{Pd})^2) / (2 * \text{Bd})$$

$$\text{Cage Frequency} = \text{RPM} * (1 - (\text{Bd} * \cos a / \text{Pd})) / 2$$

Pd = Pitch Diameter

N = Number of rollers

Bd = Roller Diameter

a = Cup Angle (contact angle)

Table 4: Type C Tapered Roller Bearing Parameters For Vibration Analysis (1-RPS)

Bore Size	# Rollers Per Row	Mean Diameter of Rollers	Pitch Diameter	Contact Angle	Cup Frequency Hz	Cone Frequency Hz	Roller Spin Frequency Hz	Cage Frequency Hz
1-3/16 - 1-7/16	19	0.31	2.251	14.92	8.235801	10.764199	3.566352	0.433463
1-1/2 - 1-3/4	21	0.32	2.604	11.50	9.235581	11.764419	4.009748	0.439790
1-15/16	22	0.33	2.848	15.00	9.768852	12.231148	4.261097	0.444039
2 - 2-1/4	21	0.40	3.335	16.83	9.294571	11.705429	4.113807	0.442599
2-3/16 - 2-7/16	25	0.35	3.533	18.00	11.322284	13.677716	5.002340	0.452891
2-1/2 - 2-11/16	23	0.43	3.827	16.50	10.261076	12.738924	4.398352	0.446134
2-7/16 - 2-15/16	26	0.42	4.22	16.50	11.759442	14.240558	4.978061	0.452286
3 - 3-3/16	22	0.55	4.612	16.50	9.742225	12.257775	4.137910	0.442828
3-1/4 - 3-7/16	24	0.51	4.761	16.42	10.766982	13.233018	4.618367	0.448624
3-1/2 - 4	25	0.59	5.727	18.98	11.282253	13.717747	4.807328	0.451290
4-7/16 - 4-1/2	33	0.46	3.109	11.50	14.107710	18.892290	3.308310	0.427506
4-15/16 - 5	26	0.68	6.983	18.00	11.796028	14.203972	5.090519	0.453693

$$\text{Cup Frequency} = N * \text{RPM} * (1 - (\text{Bd} * \cos a / \text{Pd})) / 2$$

$$\text{Cone Frequency} = N * \text{RPM} * (1 + (\text{Bd} * \cos a / \text{Pd})) / 2$$

$$\text{Roller Spin Frequency} = \text{Pd} * \text{RPM} * (1 - (\text{Bd} * \cos a / \text{Pd})^2) / (2 * \text{Bd})$$

$$\text{Cage Frequency} = \text{RPM} * (1 - (\text{Bd} * \cos a / \text{Pd})) / 2$$

Pd = Pitch Diameter

N = Number of rollers

Bd = Roller Diameter

a = Cup Angle (contact angle)

ENGINEERING

Table 5: Special Duty Tapered Roller Bearing Parameters For Vibration Analysis (1-RPS)

Bore Size	# Rollers Per Row	Mean Diameter of Rollers	Pitch Diameter	Contact Angle	Cup Frequency Hz	Cone Frequency Hz	Roller Spin Frequency Hz	Cage Frequency Hz
1-3/8 - 1-1/2	16	0.40	2.563	11.54	6.776702	9.223298	3.128839	0.423544
1-9/16 - 1-3/4	18	0.40	2.854	12.72	7.769570	10.230430	3.500820	0.431643
1-7/8 - 2	19	0.41	3.014	13.28	8.242255	10.757745	3.611183	0.433803
2-1/8 - 2-1/4	22	0.41	3.475	15	9.746381	12.253619	4.182764	0.443017
2-3/8 - 2-1/2	20	0.46	3.695	14.38	8.794078	11.205922	3.957897	0.439704
2-5/8 - 3	22	0.51	4.336	15.07	9.750677	12.249323	4.196146	0.443213
3-3/16 - 3-1/2	23	0.59	5.22	17.42	10.259806	12.740194	4.372280	0.446079
3-11/16 - 4	23	0.68	5.942	15.50	10.231809	12.768191	4.315984	0.444861
4-7/16 - 4-1/2	26	0.68	6.983	18	11.796028	14.203972	5.090519	0.453693
4-15/16 - 5	24	0.81	7.537	16.42	10.762960	13.237040	4.603028	0.448457
5-7/16 - 6	24	0.93	9.123	17.33	10.832249	13.167751	4.858391	0.451344
6-1/2 - 7	29	0.93	10.19	19.23	13.250482	15.749518	5.437812	0.456913
7-15/16 - 8	27	1.12	11.471	12.42	12.212741	14.787259	5.074422	0.452324
8-1/2 - 10	41	0.87	13.979	16.40	19.276067	21.723933	8.005271	0.470148
11 - 12	37	1.20	16.061	12.50	17.150534	19.849466	6.656476	0.463528

Cup Frequency = $N * RPM * (1 - (Bd * \cos a / Pd)) / 120$

Cone Frequency = $N * RPM * (1 + (Bd * \cos a / Pd)) / 120$

Roller Spin Frequency = $Pd * RPM * (1 - (Bd * \cos a / Pd)^2) / (120 * Bd)$

Cage Frequency = $RPM * (1 - (Bd * \cos a / Pd)) / 120$

Pd = Pitch Diameter

N = Number of rollers

Bd = Roller Diameter

a = Cup Angle (contact angle)

Table 6: All Steel Tapered Roller Bearing Parameters For Vibration Analysis (1-RPS)

Bore Size	# Rollers Per Row	Mean Diameter of Rollers	Pitch Diameter	Contact Angle	Cup Frequency Hz	Cone Frequency Hz	Roller Spin Frequency Hz	Cage Frequency Hz
2-11/16 - 3	27	0.36	4.114	15.50	12.361632	14.638368	5.673261	0.457838
3-1/4 - 3-1/2	26	0.51	5.120	17.57	11.765488	14.234512	4.974342	0.452519
3-15/16 - 4	33	0.48	5.814	12.50	15.170061	17.829939	6.016904	0.459699
4-7/16 - 4-1/2	29	0.60	6.503	12.92	13.196026	15.803974	5.375340	0.455035
4-15/16 - 5	32	0.61	7.355	12.50	14.704466	17.295534	5.989163	0.459515
5-7/16	27	0.84	8.272	12	12.159067	14.840933	4.875231	0.450336
5-15/16 - 6	26	0.85	8.323	12	11.701366	14.298634	4.847026	0.450053
6-7/16 - 7	32	0.81	9.748	12.50	14.702011	17.297989	5.977683	0.459438
7-1/2 - 8	27	1.12	11.471	12.42	12.212741	14.787259	5.074422	0.452324
9 - 10	32	1.28	14.026	12.03	14.571921	17.428079	5.435259	0.455373

Cup Frequency = $N * RPM * (1 - (Bd * \cos a / Pd)) / 120$

Cone Frequency = $N * RPM * (1 + (Bd * \cos a / Pd)) / 120$

Roller Spin Frequency = $Pd * RPM * (1 - (Bd * \cos a / Pd)^2) / (120 * Bd)$

Cage Frequency = $RPM * (1 - (Bd * \cos a / Pd)) / 120$

Pd = Pitch Diameter

N = Number of rollers

Bd = Roller Diameter

a = Cup Angle (contact angle)

Table 7: Spherical Roller Bearing Parameters for Vibration Analysis (1-RPS)

Basic Bearing Series	USAF/SAF-XT Bore Sizes (in)	S2000 Unisphere II Sizes (in)	Imperial Bore Sizes (in)	# Rollers Per Row	Diameter of Rollers	Pitch Diameter	Contact Angle	Outer Ring Frequency Hz	Inner Ring Frequency Hz	Spin Frequency Hz	Cage Frequency Hz
22207E1ASKM				15	0.3937	2.166	11.750	6.165339	8.834661	2.663713	0.411023
22208E1ASKM		1-3/8 - 1-1/2	1-1/8 - 1-1/2	15	0.4488	2.449	10.583	6.148942	8.851058	2.639849	0.409929
22209E1ASKM	1-7/16	1-11/16 - 1-3/4	1 5/8 - 1-3/4	17	0.4291	2.665	9.750	7.151157	9.848843	3.027139	0.420656
22210E1ASKM	1-11/16	1-15/16 - 2	1 7/8 - 2	18	0.4331	2.858	9.083	7.653247	10.346753	3.225588	0.425180
22211E1ASKM	1-15/16	2-3/16	2-3/16 - 2-1/4	19	0.4646	3.189	8.750	8.132069	10.867931	3.360826	0.428004
22213E1ASKM	2-3/16	2 -7/16	2-3/8 - 2-1/2	18	0.5827	3.795	9.083	7.635432	10.364568	3.181534	0.424191
22215E1ASKM	2 7/16 - 2-1/2	2-11/16 - 3	2-11/16 - 3	20	0.5748	4.197	8.250	8.644623	11.355377	3.583768	0.432231
22216E1ASKM	2-11/16 - 2-3/4			19	0.6535	4.48	8.167	8.128283	10.871717	3.356234	0.427804
22217E1ASKM	2-15/16 - 3			18	0.7323	4.764	8.417	7.631462	10.368538	3.177554	0.423970
22218E1ASKM	3-3/16	3-7/16	3-3/16 - 3-1/2	18	0.7795	5.079	8.833	7.635107	10.364893	3.182930	0.424173
22220E1ASKM	3-7/16 - 3-1/2	3-1 5/16 - 4	3-1 1/16 - 4	18	0.878	5.705	9.000	7.631952	10.368048	3.173794	0.423997
22222E1ASKM	3-1 5/16 - 4	4-7/16	4-7/16 - 4-1/2	17	1.0197	6.287	9.417	7.139947	9.860053	3.003844	0.419997
22224E1ASKM	4-3/16			18	1.0472	6.819	9.417	7.636487	10.363513	3.181095	0.424249
22226E1ASKM	4-7/16 - 4-1/2	4-15/16	4-15/16 - 5	18	1.1181	7.307	9.750	7.642733	10.357267	3.193282	0.424596
22228E1ASKM	4-15/16 - 5		5-7/16 - 5-1/2	18	1.2165	7.933	9.583	7.639139	10.360861	3.186035	0.424397
22230E1ASKM	5-3/16			18	1.315	8.559	9.500	7.636209	10.363791	3.179646	0.424234
22232E1ASKM	5-7/16 - 5-1/2		5-15/16 - 6	18	1.4094	9.189	9.667	7.639189	10.360811	3.185371	0.424399
22234E1ASKM	5-15/16 - 6			17	1.5827	9.74	9.833	7.139085	9.860915	2.998143	0.419946
22236E1ASKM	6-7/16 - 6-1/2		6-7/16 - 7	18	1.5591	10.157	9.417	7.637116	10.362884	3.182632	0.424284
22238E1ASKM	6-15/16 - 7			20	1.4961	10.669	10.667	8.621944	11.378056	3.497892	0.431097
22240E1ASKM	7-3/16			19	1.6142	11.021	10.833	8.133372	10.866628	3.343119	0.428072
22244E1ASKM	7-1/2 - 8			19	1.8504	12.48	10.833	8.116546	10.883454	3.300728	0.427187
23048KMB	8-7/16 - 9			29	1.1417	12.008	9.333	13.139616	15.860384	5.212536	0.453090
23052KMB	9-7/16 - 9-1/2			27	1.378	13.228	9.667	12.113633	14.886367	4.749092	0.448653
23056KMB	9-15/16 - 10-1/2			28	1.378	13.976	9.333	12.637908	15.362092	5.023115	0.451354

Outer Ring Frequency = $N * RPM * (1 - (Bd * \cos a / Pd)) / 120$
 Inner Ring Frequency = $N * RPM * (1 + (Bd * \cos a / Pd)) / 120$
 Roller Spin Frequency = $Pd * RPM * (1 - (Bd * \cos a / Pd)^2) / (120 * Bd)$
 Cage Frequency = $RPM * (1 - (Bd * \cos a / Pd)) / 120$

Pd = Pitch Diameter
 N = Number of rollers
 Bd = Roller Diameter
 a = Contact Angle

ENGINEERING



Table 8: DODGE USAF Air Handling Spherical Roller Bearing Parameters For Vibration Analysis (1-RPS)

Bore Size	Basic Bearing Series	# Rollers Per Row	Diameter of Rollers	Pitch Diameter	Contact Angle	Outer Ring Frequency Hz	Inner Ring Frequency Hz	Roller Spin Frequency Hz	Cage Frequency Hz
1-7/16	22209E1K	17	0.3937	2.5976	10.0000	7.231287	9.768713	3.225462	0.425370
1-11/16	22210E1K	19	0.3937	2.7976	9.2500	8.180471	10.819529	3.484413	0.430551
1-15/16	22211E1K	18	0.4528	3.0921	8.9200	7.698000	10.302000	3.342963	0.427667
2-3/16	22213E1K	19	0.5315	3.7110	9.2500	8.157076	10.842924	3.421302	0.429320
2-7/16 - 2-1/2	22215E1K	21	0.5315	4.1098	8.3300	9.156413	11.843587	3.802922	0.436020
2-11/16 - 2-3/4	22216E1K	20	0.5709	4.3638	8.2500	8.705275	11.294725	3.757794	0.435264
2-15/16 - 3	22217E1K	20	0.6299	4.6811	8.5000	8.669157	11.330843	3.649937	0.433458
3-3/16	22218E1K	20	0.6693	4.9602	8.8300	8.666651	11.333349	3.639636	0.433333
3-7/16 - 3-1/2	22220E1K	19	0.7677	5.5606	9.0000	8.204572	10.795428	3.554256	0.431820
3-15/16 - 4	22222E1K	19	0.8661	6.1559	9.4200	8.181428	10.818572	3.485342	0.430601
4-3/16	22224E1K	19	0.9252	6.6382	9.5800	8.194401	10.805599	3.519683	0.431284
4-7/16 - 4-1/2	22226E1K	19	0.9843	7.1358	9.9200	8.209178	10.790822	3.557887	0.432062
4-15/16 - 5	22228E1K	19	1.0630	7.7232	9.6700	8.211024	10.788976	3.565861	0.432159

Outer Ring Frequency = $N * \text{RPM} * (1 - (\text{Bd} * \cos a / \text{Pd})) / 120$

Inner Ring Frequency = $N * \text{RPM} * (1 + (\text{Bd} * \cos a / \text{Pd})) / 120$

Roller Spin Frequency = $\text{Pd} * \text{RPM} * (1 - (\text{Bd} * \cos a / \text{Pd})^2) / (120 * \text{Bd})$

Cage Frequency = $\text{RPM} * (1 - (\text{Bd} * \cos a / \text{Pd})) / 120$

Pd = Pitch Diameter

N = Number of rollers

Bd = Roller Diameter

a = Contact Angle

Table 9: Split-Spherical Roller Bearing Parameters For Vibration Analysis

Bore Size	Basic Bearing Series	# Rollers Per Row	Diameter of Rollers	Pitch Diameter	Contact Angle	Outer Ring Frequency Hz	Inner Ring Frequency Hz	Roller Spin Frequency Hz	Cage Frequency Hz
2-3/16	22213SS	17	0.559	3.414	9.000	7.125120	9.874880	2.973241	0.419125
2-7/16	22215SS	18	0.551	3.748	9.083	7.693012	10.306988	3.328155	0.427390
2-11/16	22216SS	19	0.579	3.950	8.667	8.124082	10.875918	3.341232	0.427583
2-15/16	22217SS	20	0.575	4.153	8.250	8.630263	11.369737	3.544783	0.431513
3-3/16	22218SS	19	0.654	4.435	8.167	8.114365	10.885635	3.321078	0.427072
3-7/16	22220SS	18	0.780	5.079	8.833	7.635107	10.364893	3.182930	0.424173
3-15/16 - 4	22222SS	18	0.878	5.634	9.000	7.614712	10.385288	3.132415	0.423040
4-3/16	22224SS	17	1.110	6.203	9.417	6.999864	10.000136	2.707845	0.411757
4-7/16 - 4-1/2	22226SS	18	1.047	6.727	9.417	7.617839	10.382161	3.136146	0.423213
4-15/16	22228SS	18	1.118	7.202	9.750	7.622945	10.377055	3.145244	0.423497
5-3/16	22230SS	18	1.217	7.822	9.583	7.619828	10.380172	3.139355	0.423324
5-7/16	22232SS	18	1.315	8.442	9.500	7.617307	10.382693	3.134123	0.423184
5-15/16 - 6	22234SS	18	1.409	9.059	9.667	7.619661	10.380339	3.138182	0.423314
6-7/16 - 6-1/2	22236SS	18	1.409	9.059	9.667	7.619661	10.380339	3.138182	0.423314
6-15/16 - 7	22238SS	18	1.559	10.021	9.417	7.618619	10.381381	3.138004	0.423257
7-3/16	22240SS	16	1.579	10.716	9.417	6.837308	9.162692	3.322243	0.427332
7-1/2 - 8	22244SS	16	1.752	11.257	9.500	6.771984	9.228016	3.136916	0.423249
8-1/2 - 9	23048SS	20	1.307	11.189	8.083	8.843406	11.156594	4.222831	0.442170
9-1/2	23052SS	22	1.339	11.949	8.417	9.780985	12.219015	4.408432	0.444590
10	23056SS	20	1.539	13.175	8.667	8.844916	11.155084	4.222170	0.442246

Outer Ring Frequency = $N * RPM * (1 - (Bd * \cos a / Pd)) / 12$
 Inner Ring Frequency = $N * RPM * (1 + (Bd * \cos a / Pd)) / 120$
 Roller Spin Frequency = $Pd * RPM * (1 - (Bd * \cos a / Pd)^2) / (120 * Bd)$
 Cage Frequency = $RPM * (1 - (Bd * \cos a / Pd)) / 120$

Pd = Pitch Diameter
 N = Number of rollers
 Bd = Roller Diameter
 a = Contact Angle

ENGINEERING

Table 10: USDAF Spherical Roller Bearing Parameters For Vibration Analysis (1-RPS)

Bore Size	Basic Bearing Series	# Rollers Per Row	Diameter of Rollers	Pitch Diameter	Contact Angle	Outer Ring Frequency Hz	Inner Ring Frequency Hz	Roller Spin Frequency Hz	Cage Frequency Hz
10-15/16 - 11	23060K	27	1.575	15.066	9.5	12.108065	14.891935	4.732011	0.448447
11-7/16 - 12	23064K	28	1.575	15.85	9.333	12.627248	15.372752	4.983368	0.450973
12-7/16 - 12-1/2	23068K	27	1.732	17.007	9.5	12.144010	14.855990	4.860109	0.449778
12-15/16 - 13-1/2	23072K	28	1.732	17.793	9.333	12.655257	15.344743	5.089157	0.451973
13-15/16 - 14	23076K	30	1.732	18.587	9	13.619458	16.380542	5.320311	0.453982
15	23080K	29	1.929	19.822	9.167	13.106938	15.893062	5.090472	0.451963
15-3/4	23084K	30	1.929	20.609	9	13.613287	16.386713	5.296232	0.453776
9-7/16 - 9-1/2	23152K	23	1.693	13.914	12.5	10.133894	12.866106	4.051285	0.440604
10-7/16 - 10-1/2	23156K	24	1.732	14.711	12	10.618053	13.381947	4.190502	0.442419
10-15/16 - 11	23160K	23	1.89	15.923	12.333	10.166494	12.833506	4.155793	0.442021
11-15/16 - 12	23164K	23	2.087	17.044	12.833	10.127024	12.872976	4.025170	0.440305
12-7/16 - 12-1/2	23168K	23	2.244	18.272	12.833	10.122953	12.877047	4.012925	0.440128
13-7/16 - 13-1/2	23172K	24	2.244	19.077	12.333	10.621032	13.378968	4.194537	0.442543
13-15/16 - 14	23176K	25	2.323	19.833	12	11.067894	13.932106	4.212801	0.442716
8-15/16 - 9	23248K	20	1.929	13.523	14	8.615913	11.384087	3.438035	0.430796
9-7/16 - 9-1/2	23252K	19	2.126	14.745	14	8.170935	10.829065	3.399907	0.430049
10-7/16 - 10-1/2	23256K	20	2.126	15.537	13.583	8.669925	11.330075	3.589401	0.433496
10-15/16 - 11	23260K	20	2.323	16.706	13.833	8.649811	11.350189	3.530230	0.432491
11-15/16 - 12	23264K	20	2.441	17.878	14	8.675192	11.324808	3.597751	0.433760
12-7/16 - 12-1/2	23268K	20	2.638	19.048	14.167	8.657198	11.342802	3.545213	0.432860

Outer Ring Frequency = $N * RPM * (1 - (Bd * \cos a / Pd)) / 120$

Inner Ring Frequency = $N * RPM * (1 + (Bd * \cos a / Pd)) / 120$

Roller Spin Frequency = $Pd * RPM * (1 - (Bd * \cos a / Pd)^2) / (120 * Bd)$

Cage Frequency = $RPM * (1 - (Bd * \cos a / Pd)) / 120$

Pd = Pitch Diameter

N = Number of rollers

Bd = Roller Diameter

a = Contact Angle

Mounted Bearings Life Adjustment Factor

1.1 GENERAL. For certain applications, it is desirable to specify life for reliability other than 90%. In such cases a life adjustment factor for reliability may be applied to the RATING LIFE. Section 1.2 discusses life adjustment factors for reliability.

Some bearing steels; e.g., vacuum-melted steels, and improved processing techniques, permit manufacture of bearings which offer endurance greater than that calculated by the RATING LIFE formula. Section 1.3 recommends methods to incorporate life adjustment factors for bearing materials into the life formula.

Bearing life calculated according to the RATING LIFE formula assumes proper application conditions. If lubrication is not adequate, loading unusual, or temperatures extreme, the ability of the bearing to attain or exceed the RATING LIFE is seriously impaired. Section 1.4 contains some basic recommendations concerning the effect of unusual application conditions on bearing life.

1.2 LIFE ADJUSTMENT FACTOR FOR RELIABILITY.

Bearing life estimated in accordance with this standard is RATING LIFE; i.e., the life associated With 90% reliability or the life which 90% of a group of apparently identical bearings in a given application under similar conditions of load and speed will complete or exceed. While RATING LIFE has proven useful over a period of years as a criterion of performance, some applications require definition of life at reliabilities greater than 90%.

To determine bearing life with reliabilities other than 90% (as previously calculated from the Selection Procedure) the L_{10} must be adjusted by a factor a_1 , such that $L_n = a_1 \times L_{10}$.

The life adjustment factors for reliability of Table 11 are recommended.

Table 11: Life Adjustment Factors For Reliability

Reliability %	L_n	Life Adjustment Factor for Reliability a_1
90	L_{10}	1
95	L_5	0.62
96	L_4	(Rating Life)
97	L_3	
98	L_2	
99	L_1	0.21

1.3 LIFE ADJUSTMENT FACTOR FOR MATERIAL. For bearings, which incorporate improved materials and processing, the L_{10} (as previously calculated in Selection Procedure) must be adjusted by a factor a_2 . Factor a_2 depends upon steel analysis, metallurgical processing, forming methods, heat treatment and manufacturing methods in general.

Bearings fabricated from consumable vacuum remelted steels and certain other special analysis steels have demonstrated extraordinarily long endurance. These steels are of exceptionally high quality, and bearings fabricated from these are usually considered special manufacture. As such, a_2 values will not be specified for such steels in this discussion. Generally, a_2 values for such steels can be obtained from the bearing manufacturer.

ENGINEERING/TECHNICAL



1.4 LIFE ADJUSTMENT FACTOR FOR APPLICATION CONDITIONS. Application conditions which affect bearing life include:

1. Lubrication.
 2. Load distribution (including effects of clearance, misalignment, housing, and shaft stiffness, type of loading and thermal gradients).
 3. Temperature.
- Consideration of (1.2) and (1.3) above requires analytical and experimental techniques beyond the scope of this discussion, therefore, the user should consult the bearing manufacturer for evaluations and recommendations.

In most bearing applications, lubrication serves to separate the rolling surfaces; i.e., rolling elements and raceways; to reduce retainer-rolling elements and retainer-land friction and sometimes to act as a coolant to remove frictional heat generated by the bearing.

If all limitations and qualifications specified by this discussion are observed, then the life adjustment application factor for bearings which are adequately lubricated is 1; i.e., $a_3=1$.

Operating conditions where a_3 might be less than 1 include:

- a. exceptionally low values of N_{dm} (rpm times bore diameter in mm); e.g., N_{dm} 1000.
 - b. Lubricant viscosity less than 20.4 centistokes (100 SSU) at operating temperature.
 - c. Excessively high operating temperatures.
- When a_3 is less than 1, it may not be assumed that the deficiency in lubrication can be overcome by using an improved steel.

* C = Basic Load Rating computed in accordance with ABMA-ANSI Standards.
 $C_{90} = C \times .259$

1.5 FACTOR COMBINATIONS. A fatigue life formula embodying the foregoing life adjustment factors is:

For Ball Bearings:

$$L_n = a_1 \times a_2 \times a_3 \left(\frac{C^*}{P} \right)^3 \times \frac{(16,667)}{\text{RPM}}$$

For Tapered Roller Bearings:

$$L_n = a_1 \times a_2 \times a_3 \left(\frac{C_{90}^*}{P} \right)^{10/3} \times \frac{(1,5000,000)}{\text{RPM}}$$

For Spherical Roller Bearings:

$$L_n = a_1 \times a_2 \times a_3 \left(\frac{C^*}{P} \right)^{10/3} \times \frac{(16,667)}{\text{RPM}}$$

Indiscriminate application of the life adjustment factors in this formula may lead to serious over-estimation of bearing endurance, since fatigue life is only one criterion for bearing selection.

Care must be exercised to select bearings which are of sufficient size for the application. Undersizing of shaft and housing structures by using bearings which appear adequate from a life standpoint could lead to misalignment and fitting problems which could invalidate the formulas in this discussion.

V-Belt Drive Formulas

V-belt tensioning In cases where tensioning of a drive effects belt pull and bearing loads, the following formulas may be used.

$$T_1 - T_2 = 33,000 \left(\frac{HP}{V} \right)$$

where: T_1 = tight side tension, pounds
 T_2 = slack side tension, pounds
 HP = design horsepower
 V = belt speed, feet per minute

$$T_1 + T_2 = 33,000 (2.5-G) \left(\frac{HP}{GV} \right)$$

where: T_1 = tight side tension, pounds
 T_2 = slack side tension, pounds
 HP = design horsepower
 V = belt speed, feet per minute*
 G = arc of contact correction factor*

$$T_1/T_2 = \frac{1}{1-0.8G} \quad (\text{Also } T_1/T_2 = e^{K\theta})$$

where: T_1 = tight side tension, pounds
 T_2 = slack side tension, pounds
 G = arc of contact correction factor*
 e = base of natural logarithms
 K = .51230, a constant for V-belt drive design
 θ = arc of contact in radians

$$T_1 = 41,250 \left(\frac{HP}{GV} \right)$$

where: T_1 = tight side tension, pounds
 HP = design horsepower
 V = "belt speed, feet per minute
 G = arc of contact correction factor

$$T_2 = 33,000 (1.25-G) \left(\frac{HP}{GV} \right)$$

where: T_2 = slack side tension, pounds
 HP = design horsepower
 V = belt speed, feet per minute
 G = arc of contact correction factor

Belt Speed

$$V = \frac{(PD)(rpm)}{3.82} = (PD)(rpm) (.262)$$

where: V = belt speed, feet per minute
 PD = pitch diameter of sheave or pulley
 rpm = revolutions per minute of the same sheave or pulley

* See Table 12 at left

Table 12: Arc of Contact Correction Factors G and R

$\frac{D-d}{C}$	Small Sheave Arc of Contact	Factor G	Factor R	$\frac{D-d}{C}$	Small Sheave Arc of Contact	Factor G	Factor R
.00	180°	1.00	1.000	.80	133°	.87	.917
.10	174°	.99	.999	.90	127°	.85	.893
.20	169°	.97	.995	1.00	120°	.82	.866
.30	163°	.96	.989	1.10	130°	.80	.835
.40	157°	.94	.980	1.20	106°	.77	.800
.50	151°	.93	.968	1.30	99°	.73	.760
.60	145°	.91	.954	1.40	91°	.70	.714
.70	139°	.89	.937	1.50	83°	.65	.661

D = Diam. of large sheave. d = Diam. of small sheave
 C = Center distance

Table 13: Allowable Sheave Rim Speed

Sheave Material	Rim Speed in Feet per Minute
Cast Iron	6,500
Ductile Iron	8,000
Steel	10,000

Note: Above rim speed values are maximum for normal considerations. In some cases these values may be exceeded. Consult factory and include complete details of proposed application.

Bearing Load Calculations

To find actual bearing loads it is necessary to know machine component weights and values of all other forces contributing to the load. Sometimes it becomes desirable to know the bearing load

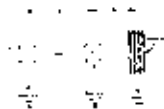

Overhung Sheave

$$\text{Load at B, lbs.} = \frac{\text{Shaft Load} \times (a + b)}{a}$$

$$\text{Load at A, lbs} = \text{Shaft Load} \times \frac{b}{a}$$

Where: a and b = Spacing, inches

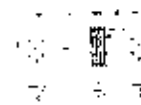

Sheave Between Bearings

$$\text{Load at D, lbs.} = \frac{\text{Shaft Load} \times c}{c + d}$$

$$\text{Load at C, lbs} = \frac{\text{Shaft Load} \times d}{c + d}$$

Where: c and d = Spacing, inches

Nominal V-Belt Cross Sections

Table 14: Nominal V-Belt Cross Sections

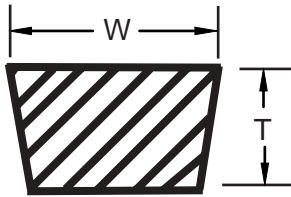

Belt Section	Industry Standard Description	Width W, in Inches	Thickness T, in Inches
3L	FHP, Single	3/8	7/32
4L		1/2	5/16
5L		21/32	3/8
3V	Narrow	3/8	5/16
5V		5/8	17/32
8V		1	29/32
A	Classical Multiple	1/2	5/16
B		21/32	13/32
C		7/8	17/32
D		1-1/4	3/4

Conveyor Belt FPM to RPM

Pulley Dia. Inches	FPM												
	100	150	200	250	300	350	400	500	600	700	800	900	1000
6	64	95	127	159	191	223	254	318	382	445	509	573	636
8	48	72	95	119	143	167	191	239	286	334	382	429	477
10	38	57	76	95	115	134	153	191	229	267	305	344	382
12	32	48	64	80	95	111	127	159	191	223	254	286	318
14	27	41	55	68	82	95	109	136	164	191	218	245	273
16	24	36	48	60	72	83	95	119	143	167	191	215	239
18	21	32	42	53	64	74	85	106	127	148	170	191	212
20	19	29	38	48	57	67	76	95	115	134	153	172	191
24	16	24	32	40	48	56	64	80	95	111	127	143	159
30	13	19	25	32	38	45	51	64	76	89	102	115	127
36	11	16	21	27	32	37	42	53	64	74	85	95	106
42	9	14	18	23	27	32	36	45	55	64	73	82	91
48	8	12	16	20	24	28	32	40	48	56	64	72	80
54	7	11	14	18	21	25	28	35	42	49	57	64	71
60	6	10	13	16	19	22	25	32	38	45	51	57	64

For values not shown use formula below:

$$SFM = .2618 \times D \times RPM$$

SFM = Surface feet Per Minute

D = Pulley Diameter, Inches

RPM = Revolutions per Minute

Table 15: Material Characteristics

MATERIAL	DENSITY (LB/FT ³)	ANGLE OF REPOSE (DEG)	RECOM-MENDED MAXIMUM INCLINATION (DEG)	MATERIAL	DENSITY (LB/FT ³)	ANGLE OF REPOSE (DEG)	RECOM-MENDED MAXIMUM INCLINATION (DEG)
Alfalfa, Ground	16	45°		Corn, Shelled	45	25°	10
Alum, Lumpy	50 - 60	35°		Corn Sugar	30	35°	
Alum, Pulverized	45 - 50	35°		Corn Grits	40 - 45	35°	
Alumina	60	30°	10-12	Cornmeal	32- 40	35°	22
Aluminum Oxide	70 - 120	30°		Cottonseed, Dry, De-Linted	35	35°	16
Ammonium Sulphate	45 - 60	45°		Cottonseed, Dry, Not De-Linted	18- 25	45°	19
Asbestos, Shredded	20 - 25	45°		Cottonseed, Cake, Lumpy	40- 45	35°	
Ashes, Dry	35 - 40	45°		Cottonseed, Hulls	12	45°	
Ashes, Wet	45 - 50	45°		Cottonseed, Meal	35- 40	35°	22
Ashes, Soft Coal	35 - 45	40°		Cottonseed, Meats	40	35°	
Asphalt, Crushed	45	35°		Cryolite	90-110	35°	
Bagasse	7.50	45°		Cullet	80-120	35°	20
Bakelite, Powder	30 - 40	45°		Diatomaceous Earth	11- 14	35°	
Baking Powder	40 - 50	35°		Dolomite, Lumpy	90-100	35°	22
Bark, Wood Refuse	10 - 20	45°	27	Dolomite, Pulverized	46	40°	
Barley	38	25°	10-15	Earth, Dry*	70- 80	35°	20
Basalt	80 - 120	25°		Earth, Moist	75-110	40°	23
Bauxite, Crushed	75 - 85	35°	20	Earth, Fullers Dry	30- 35	23°	20
Beans, Castor, Whole	30 - 45	25°	8-10	Emery	225	25°	
Beans, Cocoa	30 - 45	35°		Epsom Salt	40- 50	35°	
Beans, Navy	50	25°		Feldspar, Lumps	70-100	35°	17
Beans, Whole	45	45°		Feldspar, Dust	80-100	40°	
Bentonite, Crude	35 - 40	45°		Fish, Meal	35- 40	40°	
Bentonite, Fine	50 - 60	45°		Fish, Scrap	40- 50	0°	
Bones, Pulverized	50 - 60	45°		Flaxseed, Whole	45	25°	12
Borax, Fine	50 - 55	35°		Flaxseed, Meal	25	35°	
Borax Coarse	60 - 70	35°		Flour, Wheat	35- 40	45°	21
Bran	16	35°		Flue Dust, Dry	30- 40	20°	
Brewers Grain, Dry	25 - 35	45°		Fluorspar, Dust	85- 95	45°	
Brewers Grain, Wet	55 - 60	45°		Fluorspar, Lumps	80-110	45°	
Buck Wheat	40	25°	11-13	Foundry, Refuse	60- 80	35°	
Calcium, Carbide	70 - 80	35°		Foundry Sand, Loose	80- 90	35°	
Carbon Black, Pellets	25	25°		Foundry Sand, Rammed	100-110	0°	
Carbon Black, Powder	5	35°		Galena	250	35°	
Cast Iron Chips	100 -120	45°		Garbage, Average	30	25°	
Cement, Clinker	75 - 90	35°		Glass, Batch Fiber	45 - 55	10°	
Cement, Portland	80 -100	35°	20-23	Glass, Batch Wool	80-100	35°	20-22
Chalk, Fine	65 - 75	45°		Glass, Broken	80-100	10°	
Chalk, Lumpy	80 - 95	45°		Glue, Animal, Flaked	35	25°	
Charcoal, Wood	15 - 30	35°	20-25	Glue, Vegetable, Powdered	40	35°	
Chromium Ore	125 - 140	35°		Gluten, Meal	39	35°	
Cinders, Coal	40	35°	20	Granite, Lumps	150 -170	25°	
Clay, Dry, Fine	100 - 120	35°	20-22	Graphite, Flakes	40	35°	
Clay, Dry, Lumpy	60 - 75	35°	18-20	Graphite, Powder	30	25°	
Coal, Anthracite, Coarse	60 - 70	35°	18	Graphite, Ore	65 - 75	35°	
Coal, Anthracite, Loose	50 - 60	30°	16	Grass Seed	10	35°	
Coal, Bituminous, Coarse	50 - 60	35°	18	Gravel, Dry	90-100	35°	15-17
Coal, Bituminous, Loose	45 - 50	35°	16	Gravel, Wet	100-120	35°	
Cocoa Nibs	35 - 40	35°		Gypsum, Lumps	90-100	35°	15
Coconut, Shredded	20 - 25	45°		Gypsum, Ground	75- 80	35°	21
Coffee, Fresh Beans	30 - 40	35°	10-15	Hay, Loose	5	0°	
Coffee, Roasted Beans	22 - 30	25°		Hay, Pressed	25	0°	
Coke, Loose	23 - 32	35°	18	Hominy	35- 50	35°	
Coke Pulverized	25 - 35	45°	20-22	Hops, Spent, Dry	25- 35	45°	
Coke, Petroleum Calcinated	35 - 45	35°	20	Hops, Spent, Wet	55- 60	45°	
Concrete, Cinder	112	0°	12-30	Ice, Crushed	35- 40	20°	
Concrete, Gravel & Sand	150	0°		Ilmenite Ore	140-160	35°	
Copper Ore	120 - 150	35°	20	Iron Ore	120-180	35°	18-20
Copper Sulfate	75 - 85	30°	17	Iron Ore, Pellets	120-140	35°	13-15
Cork, Ground	5 - 15	45°		Iron Sulphate	50- 75	35°	
Corn, On Cob	45	0°		Iron Sulfide	120-140	35°	

Table 16: Material Characteristics

MATERIAL	DENSITY (LB/FT ³)	ANGLE OF REPOSE (DEG)	RECOM-MENDED MAXIMUM INCLINATION (DEG)	MATERIAL	DENSITY (LB/FT ³)	ANGLE OF REPOSE (DEG)	RECOM-MENDED MAXIMUM INCLINATION (DEG)
Kaolin, Clay	60	35°	19	Rubber, Pellets	50 - 55	35°	22
Lactose	30	35°		Rubber, Ground Scrap	25 - 35	45°	18
Lead Ore, Crushed	180 - 270	30°		Rye	42 - 45	25°	8
Lead Oxides	60 - 150	40°		Rye Meal	35 - 40	20°	
Lead Sulfate	170 - 190	45°		Salt Cake	80 - 95	30°	21
Lead Sulfide	240 - 260	35°		Salt, Coarse"	45 - 55	35°	18-22
Lignite, Air Dried	45 - 55	35°		Salt, Fine"	70 - 80	35°	11
Lime, Ground	60 - 65	40°	23	Sand, Wet	110 - 130	45°	20-22
Lime, Hydrated	40	40°	21	Sand, Dry	90 - 110	35°	16-18
Lime, Pebble	30 - 40	40°	17	Sand, Loose, Foundry	80 - 100	35°	22
Limestone, Loose	80 - 100	35°	20	Sand, Foundry, Rammed	100 - 110	0°	24
Limestone, Pulverized	85 - 90	45°	18	Sandstone	80 - 90	35°	
Linseed, Whole	45 - 50	25°		Sawdust	10 - 25	30°	22
Linseed, Meal	30 - 40	35°	20	Scale, Rolling Mill	125 - 160	45°	
Magnesium Chloride	30 - 35	40°		Sewage Sludge, Dry	45 - 55	35°	
Magnesium Sulfate	40 - 60	35°		Sewage Sludge, Wet	50 - 60	35°	
Malt, Dry	25 - 30	30°		Shale, Broken	90 - 100	25°	
Malt, Wet	60 - 65	45°		Shale, Crushed	85 - 90	40°	22
Malt, Meal	35 - 40	35°		Silica Gel, Dry	45	35°	
Manganese Ore	125 - 140	40°		Slag, Blast Furnace	80 - 90	25°	10
Manganese Oxide	120	35°		Slag, Granular, Dry	60 - 65	25°	13-16
Manganese Sulfate	70	35°		Slag, Granular, Wet	90 - 100	45°	20-22
Manure	25	0°		Slate, Ground	80 - 90	30°	15
Marble, Crushed	80 - 95	35°		Slate, Lumps	85 - 95	0°	
Marl	80	35°		Snow, Compacted	15 - 50	0°	
Mica, Flakes	20	20°		Soap	10 - 25	35°	
Mica, Ground	15	35°	23	Soda Ash, Briquettes	50	20°	7
Milk, Dried, Flaked	5	35°		Soda Ash, Heavy	55 - 65	30°	19
Milk, Malted	25 - 35	45°		Soda Ash, Light	20 - 35	35°	22
Milk, Powdered	20 - 30	40°		Sodium Aluminum, Ground	72	35°	
Milo Maize	55 - 60	35°		sodium Nitrate, Ground	70 - 80	24°	11
Molybdenum Ore	100 - 110	40°		Sodium Phosphate	50 - 65	35°	
Mortar, Wet	150	0°		soybeans, Cracked	30 - 40	35°	15-18
Niacin	35	35°		soybeans, Whole"	45 - 50	25°	12-16
Nickel-Cobalt Sulfate Ore	80 - 150	35°		starch, Powdered	25 - 45	25°	12
Oats	25 - 35	25°	10	steel, Chips	100 - 150	35°	18
Oats, Rolled	20	35°		steel, Turnings	60 - 120	45°	
Oil Cake	50	45°		sugar, Cane, Raw	55 - 65	45°	
Oxalic Acid Crystals	60	35°		sugar, Granulated, Dry	50 - 55	35°	
Oyster Shells, Ground	50 - 60	35°		sugar, Granulated, Wet	55 - 65	40°	
Oyster Shells, Whole	80	35°		Sugar Cane, Knifed	15 - 18	45°	
Paper Pulp Stock	40 - 60	20°		Sulphur, Lumps	80 - 85	35°	
Peanuts, Shelled	35 - 45	35°		Sulphur, Dust	50 - 70	35°	
Peanuts, Not Shelled	15 - 20	35°		Saonite, Pellets	120 - 140	35°	13-15
Peas, Dried	45 - 50	0°		Salc, Granulated	50 - 70	20°	
Phosphate, Fertilizer	50 - 60	35°	30	Titanium Dioxide	140	35°	
Phosphate, Rock, Crushed	60 - 100	35°	25	Titanium Sponge	60 - 70	45°	
Potash	70 - 80	30°		Tobacco, Leaves	14	45°	
Potassium Chloride	120 - 130	35°		Tobacco, Scraps	15 - 25	45°	
Potassium Nitrate	75 - 80	25°		Tobacco, Stems	15	45°	
Potassium Sulfate	45	45°		Traprock, Crushed	95 - 110	35°	
Potatoes, White"	48	0°		Traprock, Lumps	100 - 110	35°	
Pumice, Ground	40 - 45	45°		Turf	20 - 30	0°	
Pyrites, Lumps	135 - 145	25°		Walnut, Shells	35 - 45	35°	
Pyrites, Pellets	120 - 130	35°		Wheat	48	25°	12
Quartz, Lumps	95 - 100	25°		Wheat, Cracked	40 - 45	35°	
Quartz, Sand	70 - 80	25°		Wheat Germ, Dry	20 - 30	25°	27
Rice, Hulled	45 - 50	20°	8	Wood Chips	10 - 30	45°	22
Rice, Rough	35	35°		Zinc Ore, Granular	160	35°	
Rice, Grits	40 - 45	35°		Zinc Oxide	10 - 35	45°	
Rock, Crushed	100 - 150	30°					

Shafting

Table 17: Typical Commercial Shaft Tolerances

Shaft Size	Plus	Minus
Up to 1-1/2"	.000	.002
Over 1-1/2 to 2-1/2"	.000	.003
Over 2-1/2 to 4"	.000	.004
Over 4 to 6"	.000	.005
Over 6 to 8"	.000	.006
Over 8 to 9"	.000	.007
Over 9"	.000	.008

Table 18: Shaft Tolerances

Shaft Size	Tolerance, Inches
Up to 1-1/2"	+ .0000 - .0005"
1-5/8 to 4"	+ .000 - .001"
4-7/16 to 6"	+ .000 - .0015"
6-7/16 to 8"	+ .000 - .002"

Table 18 lists the recommended tolerances for all set-screw locking, eccentric locking and D-LOK locking ball and roller bearings

Table 19: Shaft Tolerances

Shaft Size	Tolerance, Inches
Up to 1-1/2"	+ .000 - .002"
1-9/16 to 2-1/2"	+ .000 - .003"
2-5/8 to 4"	+ .000 - .004"
4-3/16 to 6"	+ .000 - .005"
6-7/16" and above	+ .000 - .006"

Table 19 list the recommended tolerances for all tapered adapter sleeve ball and roller bearings

Selection of Shaft Diameters

Table 20 thru Table 23 inclusive can be used to find approximate shaft diameter for various service conditions For greater accuracy use chart under heading "Combined Torsion and Bending of Standard Shafts" (G6-19).

Tables and chart are based upon a safe shear stress of 6,000 pounds per square inch for standard keyseated shafting. Be generous in the selection of shaft diameters as

Standard Shafting-Table 17 indicates standard shafting is cold drawn in the smaller sizes and turned and polished in the larger diameters. It has a smooth surface, is commercially straight and is readily machinable; suitable and recommended for general power transmission and material handling service.

Special Shafting-While standard shafting is suitable for most installations, special shafting is sometimes required for certain chemical, temperature or physical requirements. Such materials as high carbon steel, alloy steel, stainless steel, brass, Monel metal, etc., can be furnished plain or heat treated. Stepped, flanged, hollow or other special forms are available.

Special shafting should be avoided in favor of standard shafting wherever possible because special shafting is usually considerably more expensive and requires a greater length of time to obtain, which is an especially important consideration should quick replacement ever become necessary.

Ordering Shafting-Standard shafting can be obtained from most supply houses and dealers who handle power transmission material.

Turning Down Shaft Ends-When necessary to turn down shaft ends, use as large a fillet as possible to keep the stress concentration to a minimum. The radius of this fillet should preferably be not less than the difference in the two diameters joined by the fillet. The fillet should be finished and polished as smoothly as possible to avoid scratches which might start cracks and failure of the shaft by fatigue.

liberal diameters not only reduce deflection and vibration but also generally increase bearing life.

When necessary to use other than standard shafting, find the required diameter for standard shafting as outlined above and multiply by proper factor shown in Table 24 , under heading "Factors for Shafting Other than Standard Shafting."(G6-18).

Selection of Shaft Diameters (Cont'd)

Table 20: No Bending Moment (Shafts without pulleys, sprockets or gears - Torsion only)

Shaft Size	Horse Power at Various Revolutions per Minute																		
	25	50	75	100	125	150	175	200	225	250	275	300	350	400	500	600	700	800	900
15/16	0.30	0.70	1.10	1.50	1.90	2.30	2.60	3	3.40	3.80	4.20	4.60	5.30	6.10	7.70	9.20	10.70	12.30	13.80
1-3/16	0.70	1.50	2.30	3.10	3.90	4.60	5.40	6.20	7	7.80	8.60	9.30	10.90	12.50	15.60	18.70	21.90	25	28.10
1-7/16	1.30	2.70	4.10	5.50	6.90	8.30	9.70	11.10	12.40	13.80	15.20	16.60	19.40	22.20	27.70	33.30	38.80	44.40	49.90
1-11/16	2.20	4.40	6.60	8.90	11.20	13.40	15.70	17.90	20.20	22.40	24.70	26.90	31.40	35.90	44.90	53.80	62.80	71.80	80.80
1-15/16	3.30	6.70	10.10	13.50	16.90	20.30	23.70	27.10	30.50	33.90	37.30	40.70	47.50	54.30	67.90	81.50	95.10	108	122
2-3/16	4.90	9.80	14.60	19.50	24.40	29.30	34.20	39.10	44	48.90	53.80	58.60	68.40	78.20	97.80	117	136	156	176
2-7/16	6.70	13.50	20.20	27	33.80	40.60	47.30	54.10	60.90	67.60	74.40	81.20	94.70	108	135	162	189	216	243
2-11/16	9	18.10	27.10	36.20	45.30	54.40	63.40	72.50	81.60	90.70	99.70	108	126	145	181	217	253	290	326
2-15/16	11.80	23.60	35.40	47.30	59.20	71	82.90	94.70	106	118	130	142	165	189	236	284	331	379	426
3-7/16	19	37.90	57	75.90	94.90	113	132	151	170	189	208	227	265	303	379	455	531	607	683
3-15/16	28.50	57	85.50	114	142	171	199	228	256	285	313	342	399	456	570	684	798	912	1026
4-7/16	40.80	81.60	122	163	204	245	286	327	367	408	449	490	572	653	816	980	1143	1306	1470

Table 21: Limited Bending Moment (Pulleys, sprockets or gears near bearings. Ordinary line shafts.)

Shaft Size	Horse Power at Various Revolutions per Minute																		
	25	50	75	100	125	150	175	200	225	250	275	300	350	400	500	600	700	800	900
15/16	0.20	0.50	0.70	1	1.20	1.50	1.70	2	2.30	2.50	2.80	3	3.50	4.10	5.10	6.10	7.10	8.20	9.20
1-3/16	0.50	1	1.50	2	2.60	3.10	3.60	4.10	4.70	5.20	5.70	6.20	7.30	8.30	10.40	12.50	14.60	16.70	18.80
1-7/16	0.90	1.80	2.70	3.70	4.60	5.50	6.40	7.40	8.30	9.20	10.10	11.10	12.90	14.80	18.50	22.20	25.90	29.60	33.30
1-11/16	1.40	2.90	4.30	5.90	7.40	8.90	10.40	11.90	13.40	14.90	16.40	17.90	20.90	23.90	29.90	35.90	41.90	47.90	53.90
1-15/16	2.20	4.50	6.70	9	11.30	13.60	15.80	18.10	20.40	22.60	24.90	27.20	31.70	36.20	45.30	54.40	63.40	72.50	81.60
2-3/16	3.20	6.50	9.70	13	16.30	19.50	22.80	26.10	29.30	32.60	35.80	39.10	45.60	52.20	65.20	78.30	91.30	104	117
2-7/16	4.50	9	13.50	18	22.50	27	31.60	36.10	40.60	45.10	49.60	54.10	63.20	72.20	90.20	108	126	144	162
2-11/16	6	12.10	18.10	24.20	30.20	36.30	42.30	48.40	54.40	60.50	66.50	72.60	84.70	96.80	121	145	169	193	217
2-15/16	7.90	15.80	23.70	31.60	39.50	47.40	55.30	63.20	71.10	79	86.90	94.80	110	126	158	189	221	252	284
3-7/16	12.60	25.30	37.90	50.60	63.30	75.90	88.60	101	113	126	139	151	177	202	253	303	354	405	455
3-15/16	19	38	57	76.10	94.10	114	133	152	171	190	209	228	266	304	380	456	532	608	685
4-7/16	27	54	81	108	136	163	190	217	245	272	299	326	381	435	544	653	762	871	980
4-15/16	37	75	112	150	187	225	262	300	337	375	412	450	525	600	750	900	1050	1200	1350
5-7/16	50	100	150	200	250	300	350	400	451	501	551	601	701	801	1002	1202	1403	1603	1804
5-15/16	65	130	195	261	326	391	456	522	587	652	717	783	913	1044	1305	1566	1827	2088	2349
6-1/2	85	171	256	342	427	513	598	684	769	855	940	1026	1197	1368	1710	2052	2394	2736	3078

Selection of Shaft Diameters (Cont'd)

Table 22: Heavy Bending Moment. (Use for main or important shafts.)

Shaft Size	Horse Power at Various Revolutions per Minute																		
	25	50	75	100	125	150	175	200	225	250	275	300	350	400	500	600	700	800	900
1-11/16	0.80	1.70	2.50	3.50	4.40	5.30	6.20	7.10	8	8.90	9.80	10.70	12.50	14.30	17.90	21.50	25.10	28.70	32.30
1-15/16	1.30	2.70	4	5.40	6.70	8.10	9.50	10.80	12.20	13.50	14.90	16.30	19	21.70	27.10	32.60	38	43.50	48.90
2-3/16	1.90	3.90	5.80	7.80	9.70	11.70	13.70	15.60	17.60	19.50	21.50	23.40	27.40	31.30	39.10	46.90	54.80	62.60	70.40
2-7/16	2.70	5.40	8.10	10.80	13.50	16.20	18.90	21.60	24.30	27	29.70	32.40	37.90	43.30	54.10	64.90	75.80	86.60	97.40
2-11/16	3.60	7.20	10.80	14.50	18.10	21.70	25.40	29	32.60	36.20	39.90	43.50	50.80	58	72.50	87.10	101	116	130
2-15/16	4.70	9.40	14.10	18.90	23.60	28.40	33.10	37.90	42.60	47.30	52.10	56.80	66.30	75.80	94.70	113	132	151	170
3-7/16	7.50	15.10	22.60	30.30	37.90	45.50	53.10	60.70	68.30	75.90	83.50	91.10	106	121	151	182	212	243	273
3-15/16	11.40	22.80	34.20	45.60	57	68.40	79.90	91.30	102	114	125	136	159	182	228	273	319	365	410
4-7/16	16.30	32.60	48.90	65.30	81.60	98	114	130	147	163	179	196	228	261	326	392	457	522	588
4-15/16	22.50	45	67.50	90	112	135	157	180	202	225	247	270	315	360	450	540	630	720	810
5-7/16	30	60	90	120	150	180	210	240	270	300	330	360	420	480	601	721	841	961	1082
5-15/16	39	78	117	156	195	234	273	313	352	391	430	469	547	626	782	939	1095	1252	1409
6-1/2	51	102	153	205	256	308	359	410	462	513	564	616	718	821	1027	1232	1437	1643	1848
7	64	128	192	256	320	384	448	513	577	641	705	769	897	1026	1282	1539	1795	2052	2308
7-1/2	78.50	157	235	315	394	473	552	631	709	788	867	946	1104	1262	1577	1893	2208	2524	2839
8	95.50	191	286	382	478	574	670	765	861	957	1053	1148	1340	1531	1914	2297	2680	3063	3446
8-1/2	114	229	343	459	574	688	803	918	1033	1148	1263	1377	1607	1837	2296	2755	3215	3674	4133
9	136	272	408	545	681	817	954	1090	1226	1363	1499	1635	1908	2181	2726	3271	3816	4362	4907
9-1/2	160	320	480	641	801	961	1122	1282	1442	1603	1763	1923	2244	2565	3206	3847	4488	5130	5771
10	186	373	559	747	934	1121	1308	1495	1682	1869	2056	2243	2617	2991	3739	4487	5235	5983	6731

Table 23: Severe Conditions (Heavy shock loads. Excessively tight belts. long clutch sleeves.)

Shaft Size	Horse Power at Various Revolutions per Minute																		
	25	50	75	100	125	150	175	200	225	250	275	300	350	400	500	600	700	800	900
1-11/16	0.4	0.8	1.2	1.7	2.2	2.6	3.1	3.5	4	4.4	4.9	5.3	6.2	7.1	8.9	10.7	12.5	14.3	16.10
1-15/16	0.6	1.3	2	2.7	3.3	4	4.7	5.4	6.1	6.7	7.4	8.1	9.5	10.8	13.5	16.3	19	21.7	24.40
2-3/16	0.90	1.90	2.90	3.90	4.80	5.80	6.80	7.80	8.80	9.70	10.70	11.70	13.70	15.60	19.50	23.40	27.40	31.30	35.20
2-7/16	1.30	2.70	4	5.40	6.70	8.10	9.40	10.80	12.10	13.50	14.80	16.20	18.90	21.60	27	32.40	37.90	43.30	48.70
2-11/16	1.80	3.60	5.40	7.20	9	10.80	12.70	14.50	16.30	18.10	19.90	21.70	25.40	29	36.20	43.50	50.50	58	65
2-15/16	2.30	4.70	7	9.40	11.80	14.20	16.50	18.90	21.30	23.60	26	28.40	33.10	37.90	47.30	56.50	66	75.50	85
3-7/16	3.70	7.50	11.30	15.1	18.90	22.70	26.50	30.30	34.10	37.90	41.70	45.50	53	60.50	75.50	91	106	121	136
3-15/16	5.70	11.40	17.10	22.8	28.50	34.20	39.90	45.60	51	57	62.50	68	79.50	91	114	136	159	182	205
4-7/16	8.10	16.30	24.40	32.6	40.80	49	57	65	73.50	81.50	89.50	98	114	130	163	196	228	261	294
4-15/16	11.20	22.50	33.70	45	56	67.50	78.50	90	101	112	123	135	157	180	225	270	315	360	405
5-7/16	15	30	45	60	75	90	105	120	135	150	165	180	210	240	300	360	420	480	541
5-15/16	19.50	39	58.50	78	97.10	117	136	156	171	195	215	234	273	313	391	469	547	626	704
6-1/2	25.50	51	76.50	102.5	128	154	179	205	231	256	282	308	359	410	513	616	718	821	924
7	32	64.90	96	128	160	192	224	256	288	320	352	384	448	513	641	769	897	1026	1154
7-1/2	39.20	78.50	117	157	197	236	276	315	354	394	433	473	552	631	788	946	1104	1262	1419
8	47.70	95.50	143	191	239	287	335	382	430	478	526	574	670	765	957	1148	1340	1531	1723
8-1/2	57	114	171	229	287	344	401	459	516	574	631	688	803	918	1148	1377	1607	1837	2066
9	68	136	204	272	340	408	477	545	613	681	749	817	954	1090	1363	1635	1908	2181	2453
9-1/2	80	160	240	320	400	480	561	641	721	801	881	961	1122	1282	1603	1923	2244	2565	2885
10	93	186	279	373	467	560	654	747	841	934	1028	1121	1308	1495	1869	2243	2617	2991	3365

Caution - Be generous in the selection of shaft diameters as liberal diameters not only reduce deflection and vibration but also generally increase bearing life. See notes on next page.

Selection of Shaft Diameters (Cont'd)

Shaft Stiffness, Shaft Deflection-Standard shafting of adequate strength usually has a sufficiently large diameter to prevent excessive deflection in ordinary installations. It is wise to select shafting of generous diameter, as the greater the diameter, the greater the stiffness. A high tensile strength alloy shaft, although stronger, is no stiffer than a standard shaft of the same diameter.

While it is sometimes possible to use an alloy shaft of less diameter than a standard shaft of equal strength, this practice is usually inadvisable, as the deflection is increased.

Shafts carrying medium or long clutch sleeves should be especially generous.

High Speed Shafts-High speed sometimes causes shaft whipping or vibration. Making the shaft diameter generous and the distance between bearing centers short usually prevents this trouble.

Location of the bearings close to wheels and couplings is advisable whether the shaft is transmitting heavy or light loads.

The use of high tensile strength alloy shafting instead of standard shafting is of no help in preventing vibration as this will not improve the stiffness and deflection characteristics of the shaft.

Stepped Shafts- For a heavily loaded wheel, a shaft with a boss or enlarged section under the wheel and turned to a smaller diameter at the bearings often provides the most economical installation. The two different diameters should be joined by a very generous fillet, as otherwise a

dangerous concentration of stress will occur at the fillet. See heading-"Turning Down Shaft Ends." (G6-15).

Shaft Keyseats-Plain keyseats are preferable to round end keyseats in respect to causing the least concentration of stress. However, round end keyseats are often used because of design and assembly requirements. Ends left by the milling cutter should not project into babbitted or bronze bushed bearing, but may project under the sleeve of any Dodge anti-friction bearings.

Shaft diameters obtained from the tables or chart allow for the use of keyseats.

Shaft Bearings-On ordinary line shafting, bearings are commonly spaced about eight feet centers. On large diameter shafts, the spacing may be somewhat greater.

Wheels and clutches should be located near bearings to avoid dangerous bending, deflection and vibration.

Bearings should be mounted on adequate supports so that accurate alignment may be maintained. Shafting misalignment may cause shaft or bearing failure.

Shaft Couplings-Where a rigid coupling is used, it is preferable to have a bearing fairly close. Where a cutoff coupling or a flexible coupling is used, locate bearings close to each end of the coupling.

Expansion of Shafting-Where changes in the length of the shaft due to changes in temperature are to be expected and the bearings are mounted on supporting structures other than steel, consideration must be given to expansion. For more detailed information see G6-20, headed: "Expansion of Shafting."

Factors for Shafting Other Than Standard Shafting

When it is necessary to use other than standard shafting, multiply required diameter for standard shafting as found in the tables or chart by proper factor from Table 24 below.

Standard keyseated shafting, using a safe shear stress of 6,000 PSI is the basis of shafting tables and chart. For safe shear stress of other materials, use 1/10 of nominal ultimate tensile strength. For example, use 8,000 for C1045 and 10,000 for 4140 keyseated shafting. When definite physical specifications are known the least of 13.5% of minimum ultimate tensile strength and 22.5% of minimum

elastic limit in tension may be used for keyseated shafting; 18% and 30% respectively if not keyseated.

Caution-As the deflection of steel shafting depends upon the diameter and not upon the analysis of the steel, care should be exercised in the use of alloy shafting not to reduce the diameter unduly. Deflection should not be excessive and bearing capacities should be adequate. It is usually best to use standard shafting instead of a smaller diameter alloy shaft. The smaller alloy shaft may safely transmit the torque but often is undesirable in respect to deflection, vibration and bearing life.

Table 24: Shear Stress Factors

Safe Shear Stress	Factor	Safe Shear Stress	Factor	Safe Shear Stress	Factor	Safe Shear Stress	Factor	Safe Shear Stress	Factor
500	2.289	3,000	1.260	5,500	1.029	9,000	.874	14,000	.754
1,000	1.817	3,500	1.197	6,000	1.000	10,000	.843	15,000	.737
1,500	1.587	4,000	1.145	6,500	.974	11,000	.817	16,000	.721
2,000	1.442	4,500	1.101	7,000	.950	12,000	.794	17,000	.707
2,500	1.339	5,000	1.063	8,000	.909	13,000	.773	18,000	.693

Combined Torsion and Bending of Standard Shafts (Based on a Safe Shear Stress of 6,000 PS for Keyseated Shafting)

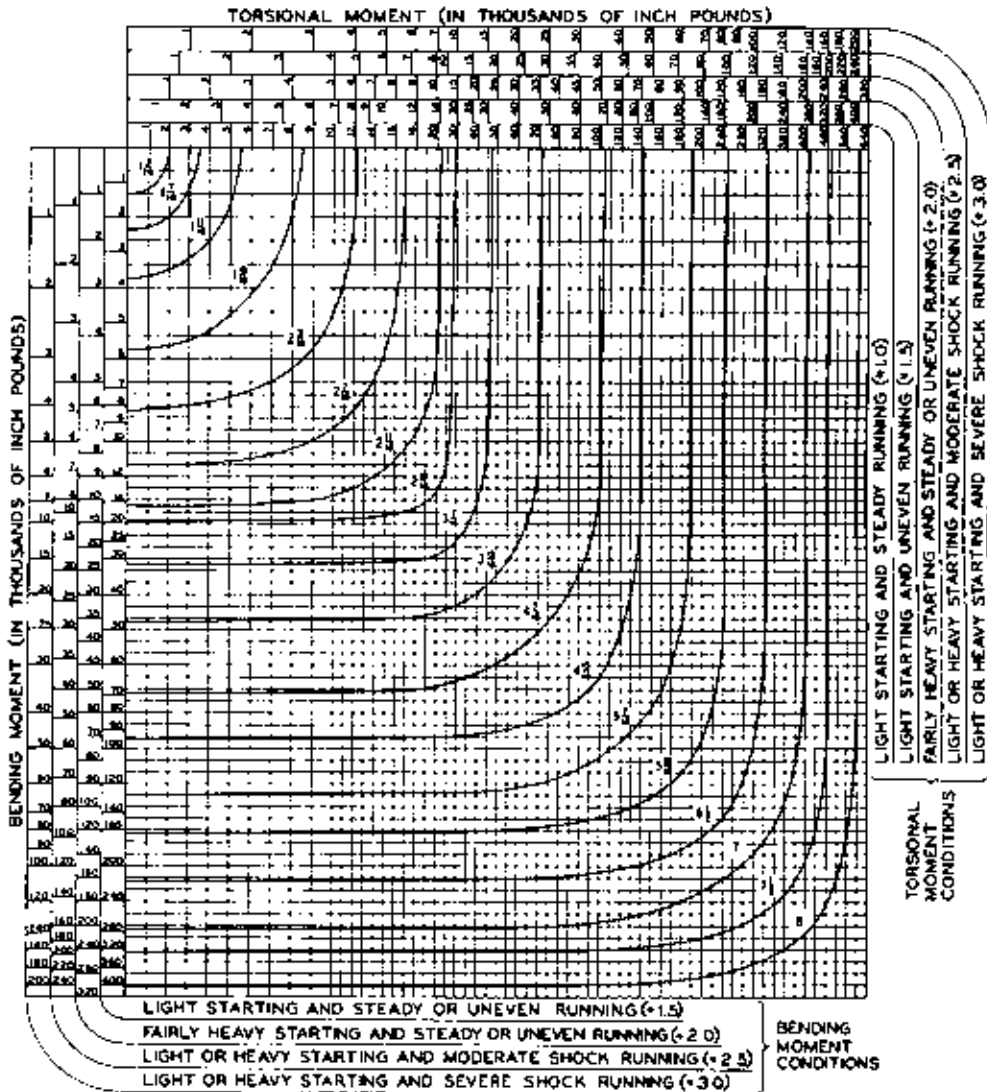

Example: Engine extension shaft driving single cylinder compressor, 15,000 pound-inches torsional moment, 14,000 pound-inches bending moment. Because of the heavy shock running load conditions use scales designated "Light or Heavy Starting and Severe Shock Running". Project a line down from 15,000 torsional moment. Project a line to the right from 14,000 bending

moment. The two lines intersect between 3-7/16 and 3-15/16 curves. Use 3-15/16 standard shafting.

Note: The above chart is based on ASME approved standard ASA-B17C-1927 withdrawn in 1954. If the latest shaft selection analysis is required refer to ANSI/ASME B106.1M-1985.

Note: If considering use of other shafting material refer to "Selection of Shaft Diameters" on page G6-18.

ENGINEERING/TECHNICAL



Expansion of Shafting

Provision should be made to permit the free movement of shafting endwise due to temperature changes. One bearing should serve as an anchor bearing to locate the shaft endwise. All other bearings should permit the shaft to move freely endwise.

The anchor bearing is often located near an important wheel. On long shafts it should preferably be located near the center of the shaft to keep the expansion of the two ends to a minimum. If the anchor bearing is babbitted it should be fitted with collars. If it is an anti-friction bearing it should be of the non-expansion type, which is the designation of Dodge roller and ball bearings for use as anchor bearings.

All bearings on the shafting other than the anchor bearing should permit the shaft to move freely endwise. If babbitted there should be no thrust collars. If anti-friction these bearings should be of the expansion type.

Several shafts firmly fastened together expand as if one continuous shaft. An example of this is line shafting with flange couplings. If the expansion is considered excessive a long line shaft may be split into two or more sections, the sections being connected with expansion couplings.

Amount of Expansion to be provided for-

The amount of shafting expansion is given in Table 25 below. For example, with a 1005 temperature rise on a 150 ft. line shaft with the anchor bearing located 70 ft. from one end and 80 ft. from the other end the ends will move .529" and .605" respectively away from the anchor bearing. The

structure supporting the bearings may also expand but usually not as rapidly and as much as does the shafting. Several cases follow:

Case 1-Bearings supported on steel structures, where the shaft and structure are exposed to the same temperatures, will expand at the same rate. Expansion allowance is usually not required. If the shaft is exposed to a higher temperature than the support, allowances should be made. For example, if the shaft temperature is expected to change 80°, and the temperature of the structure 60°, the resulting movement between shafting and support ends will be equivalent to a 20° change.

Case 2-For bearings supported on wood, brick, or concrete walls, or on piers with foundations in the ground, the amount of expansion is usually considered negligible. Therefore, the full amount of shafting expansion as calculated in Table 25 below, may be accommodated.

Case 3-Certain structural designs have built-in flexibility. Where this is the case, expansion type bearings are not necessary.

Case 4-Short shafts with only two bearings are usually designed without compensation for expansion, if temperature variations are not excessive.

Advice on Expansion Problems-

Dodge power transmission engineers will gladly make recommendations concerning shafting expansion problems and the use of suitable bearings.

Table 25: Linear Expansion of Steel Shafting

Base on Expansion In Inches = 0.0000063 x 12 x Length in Feet x Temp. Increase in Degrees Fahrenheit

Length (Feet)	Temperature Increase-Degrees F.					Length (Feet)	Temperature Increase-Degrees F.				
	20°	40°	60°	80°	100°		20°	40°	60°	80°	100°
1	.0015	.0030	.0045	.0060	.0075	40	.060	.121	.181	.242	.302
2	.0030	.0060	.0091	.0121	.0151	45	.068	.136	.204	.272	.340
3	.0045	.0091	.0136	.0181	.0227	50	.076	.151	.227	.302	.378
4	.0060	.0121	.0181	.0242	.0302	55	.083	.166	.249	.333	.416
5	.0076	.0151	.0227	.0302	.0378	60	.091	.181	.272	.363	.454
6	.0091	.0181	.0272	.0363	.0454	65	.098	.197	.295	.393	.491
7	.0106	.0212	.0318	.0423	.0529	70	.106	.212	.317	.423	.529
8	.0121	.0242	.0363	.0484	.0605	75	.113	.227	.340	.454	.567
9	.0136	.0272	.0408	.0544	.0680	80	.121	.242	.363	.484	.605
10	.0151	.0302	.0454	.0605	.0756	85	.129	.257	.386	.514	.643
12	.0181	.0363	.0544	.0726	.0907	90	.136	.272	.408	.544	.680
14	.0212	.0423	.0635	.0847	.1058	95	.144	.287	.431	.575	.718
16	.024	.048	.073	.097	.121	100	.151	.302	.454	.605	.756
18	.027	.054	.082	.109	.136	110	.166	.333	.499	.665	.832
20	.030	.060	.091	.121	.151	120	.181	.363	.544	.726	.907
25	.038	.076	.113	.151	.189	130	.197	.393	.590	.786	.983
30	.045	.091	.136	.181	.227	140	.212	.423	.635	.847	1.058
35	.053	.106	.158	.212	.265	150	.227	.454	.680	.907	1.134

Weights and Properties of Steel Shafting

Table 26: Weight of Round Steel Shafting

Shaft Size	Weight of Shafting for Various Lengths in feet																	Weight Per Inc.
	1	2	3	4	5	6	7	8	9	10	12	14	16	18	20	22	24	
3/4	1.5	3.0	4.5	6.0	7.5	9.0	10.5	12.0	13.5	15	18	21	24	27	30	33	36	1.25
7/8	2.0	4.0	6.1	8.1	10.2	12.2	14.3	16.3	18.4	20	25	29	33	37	41	45	49	.170
*15/16	2.3	4.7	7.0	9.4	11.7	14.1	16.5	18.8	21.2	23	28	33	38	42	47	52	56	.195
1	2.7	5.3	8.0	10.6	13.3	16.0	18.6	21.3	24.0	27	32	37	43	48	53	59	64	.223
1-1/8	3.4	6.8	10.0	13.4	16.7	20.1	23.4	26.7	30.1	34	41	47	54	61	68	74	81	.281
*1-3/16	3.8	7.6	11.3	15.1	18.9	22.6	26.4	30.1	34.0	38	45	53	60	68	75	83	90	.314
1-1/4	4.2	8.3	12.5	16.7	20.8	25.0	29.2	33.3	37.5	42	50	58	67	75	83	92	100	.348
1-3/8	5.0	10.1	15.3	20.2	25.3	30.3	35.4	40.4	45.4	50	60	71	81	91	101	111	121	.420
*1-7/16	5.5	11	17	22	28	33	39	44	50	55	66	77	88	99	110	121	133	.460
1-1/2	6.0	12	18	24	30	36	42	48	54	60	72	84	96	108	120	132	144	.500
*1-11/16	7.6	15	23	30	38	46	53	61	68	76	91	107	122	137	152	167	183	.634
*1-15/16	10.0	20	30	40	50	60	70	80	90	100	120	140	161	181	201	221	241	.835
2	10.7	21	32	43	53	64	75	85	96	107	128	150	171	192	214	235	256	.890
*2-3/16	12.8	26	38	51	64	77	90	102	115	128	153	179	205	230	256	281	307	1.06
*2-7/16	15.9	32	48	63	79	95	111	127	143	159	190	222	254	286	317	349	381	1.32
2-1/2	16.7	34	50	67	83	100	117	134	150	167	200	234	267	301	334	367	401	1.39
*2-11/16	19.3	39	58	77	97	116	135	154	174	193	232	270	309	348	386	425	463	1.61
*2-15/16	23.0	46	69	92	115	138	161	184	208	231	277	323	369	415	461	507	553	1.92
*3-7/16	31.6	63	95	126	158	189	221	253	284	316	379	442	505	568	631	695	758	2.63
*3-15/16	41.4	83	124	166	207	248	290	331	373	414	497	580	662	745	828	911	994	3.45
*4-7/16	52.6	105	158	210	263	315	368	421	473	526	631	736	841	946	1052	1157	1262	4.38
*4-15/16	65.1	130	195	260	326	391	456	521	586	651	781	911	1041	1172	1302	1432	1562	5.42
*5-7/16	79.0	158	237	316	395	474	553	632	711	790	947	1105	1263	1421	1579	1737	1894	6.58
*6	96	192	288	384	481	577	673	769	865	961	1154	1346	1538	1730	1923	2115	2307	8.01

* Recommended Diameters These shaft diameters are recommended for use whenever possible as various transmission items such as couplings, collars, clutches, pulleys, etc., are carried in stock in these sizes, at least up to 3-15/16", in the principal cities throughout the United States.

Table 27: Weight and Properties of Round Steel Shafting

Shaft Size	Weight per Inch	Section Modulus		Moment of Inertia		Shaft Size	Weight per Inch	Section Modulus		Moment of Inertia	
		Bending	Torsion	Bending	Torsion			Bending	Torsion	Bending	Torsion
1/16	.00087	.000024	.000048	.000001	.000002	2-7/16	1.32	1.422	2.844	1.733	3.466
1/8	.0035	.000192	.000383	.000012	.000024	2-1/2	1.39	1.534	3.068	1.918	3.835
3/16	.0078	.000647	.001294	.000061	.000121	2-9/16	1.46	1.652	3.304	2.117	4.233
1/4	.0139	.001534	.003068	.000192	.000383	2-5/8	1.53	1.776	3.552	2.331	4.661
5/16	.0217	.002966	.005932	.000468	.000936	2-11/16	1.61	1.906	3.811	2.561	5.122
3/8	.0313	.005177	.010354	.000971	.001941	2-3/4	1.68	2.042	4.084	2.807	5.615
7/16	.0425	.008221	.016442	.001798	.003597	2-13/16	1.76	2.184	4.368	3.071	6.143
1/2	.0556	.0123	.0245	.0031	.0061	2-7/8	1.84	2.333	4.666	3.354	6.707
9/16	.0703	.0175	.0349	.0049	.0098	2-15/16	1.92	2.489	4.977	3.655	7.310
5/8	.0868	.0240	.0479	.0075	.0150	3	2.00	2.651	5.301	3.976	7.952
11/16	.1051	.0319	.0638	.0110	.0219	3-1/16	2.08	2.820	5.640	4.318	8.636
3/4	.125	.0414	.0828	.0155	.0311	3-1/8	2.17	2.996	5.992	4.681	9.363
13/16	.1467	.0527	.1053	.0214	.0428	3-3/16	2.26	3.179	6.359	5.067	10.13
7/8	.1701	.0658	.1315	.0288	.0575	3-1/4	2.35	3.370	6.740	5.477	10.95
15/16	.1954	.0809	.1618	.0379	.0758	3-5/16	2.44	3.568	7.137	5.910	11.82
1	.22	.0982	.1963	.0491	.0982	3-3/8	2.53	3.774	7.548	6.369	12.74
1-1/16	.25	.1178	.2355	.0626	.1251	3-7/16	2.63	3.988	7.976	6.854	13.71
1-1/8	.28	.1398	.2796	.0786	.1573	3-1/2	2.72	4.209	8.419	7.366	14.73
1-3/16	.31	.1644	.3288	.0976	.1952	3-9/16	2.82	4.439	8.878	7.907	15.81
1-1/4	.35	.1917	.3835	.1198	.2397	3-5/8	2.92	4.677	9.353	8.476	16.95
1-5/16	.38	.2220	.4439	.1457	.2913	3-11/16	3.02	4.923	9.845	9.076	18.15
1-3/8	.42	.2552	.5104	.1755	.3509	3-3/4	3.13	5.177	10.35	9.707	19.41
1-7/16	.46	.2916	.5832	.2096	.4192	3-13/16	3.23	5.440	10.88	10.37	20.74
1-1/2	.50	.3313	.6627	.2485	.4970	3-7/8	3.34	5.712	11.42	11.07	22.14
1-9/16	.54	.3745	.7490	.2926	.5852	3-15/16	3.45	5.993	11.99	11.80	23.60
1-5/8	.59	.4213	.8425	.3423	.6846	4	3.56	6.283	12.57	12.57	25.13
1-11/16	.63	.4718	.9435	.3981	.7961	4-1/16	3.67	6.582	13.16	13.16	26.74
1-3/4	.68	.5262	1.052	.4604	.9208	4-1/8	3.78	6.891	13.78	14.21	28.42
1-13/16	.73	.5846	1.169	.5298	1.060	4-3/16	3.90	7.209	14.42	15.09	30.19
1-7/8	.78	.6471	1.294	.6067	1.213	4-1/4	4.01	7.536	15.07	16.01	32.03
1-15/16	.83	.7140	1.428	.6917	1.384	4-5/16	4.13	7.874	15.75	16.98	33.96
2	.89	.7854	1.571	.7854	1.571	4-3/8	4.25	8.221	16.44	17.98	35.97
2-1/16	.94	.8614	1.723	.8883	1.777	4-7/16	4.38	8.579	17.16	19.03	38.07
2-1/8	1.00	.9421	1.884	1.001	2.002	4-1/2	4.50	8.946	17.89	20.13	40.26
2-3/16	1.06	1.028	2.055	1.124	2.248	4-9/16	4.63	9.324	18.65	21.27	42.54
2-1/4	1.13	1.118	2.237	1.258	2.516	4-5/8	4.75	9.713	19.43	22.46	44.92
2-5/16	1.19	1.214	2.428	1.404	2.808	4-11/16	4.88	10.11	20.22	23.70	47.40
2-3/8	1.25	1.315	2.630	1.562	3.124	4-3/4	5.01	10.52	21.04	24.99	49.98

ENGINEERING/TECHNICAL



Table 27: Weight and Properties of Round Steel Shafting

Shaft Size	Weight per Inch	Section Modulus		Moment of Inertia		Shaft Size	Weight per Inch	Section Modulus		Moment of Inertia	
		Bending	Torsion	Bending	Torsion			Bending	Torsion	Bending	Torsion
4-13/16	5.15	10.94	21.88	26.33	52.66	13-1/2	40.50	241.50	483.10	1630	3261
4-7/8	5.28	11.37	22.75	27.72	55.45	13-3/4	42.00	255.20	510.40	1755	3509
4-15/16	5.42	11.82	23.63	29.17	58.35	14	43.60	269.40	538.80	1886	3771
5	5.56	12.27	24.54	30.68	61.36	14-1/4	45.10	284.10	568.20	2024	4048
5-1/16	5.70	12.74	25.48	32.24	64.49	14-1/2	46.70	299.30	598.60	2170	4340
5-1/8	5.84	13.22	26.43	33.86	67.73	14-3/4	48.40	315.00	630.10	2324	4647
5-3/16	5.98	13.70	27.41	35.55	71.09	15	50.00	331.30	662.70	2485	4970
5-1/4	6.13	14.21	28.41	37.29	74.58	15-1/4	51.70	348.20	696.40	2655	5310
5-5/16	6.27	14.72	29.44	39.10	78.20	15-1/2	53.40	365.60	731.20	2833	5667
5-3/8	6.42	15.25	30.49	40.97	81.94	15-3/4	55.10	383.60	767.10	3021	6041
5-7/16	6.58	15.78	31.57	42.91	85.82	16	56.90	402.10	804.20	3217	6434
5-1/2	6.72	16.33	32.67	44.92	89.84	16-1/4	58.70	421.30	842.50	3422	6846
5-9/16	6.88	16.90	33.79	46.99	93.99	16-1/2	60.50	441.00	882.00	3638	7277
5-5/8	7.03	17.47	34.95	49.14	98.29	16-3/4	62.40	461.40	922.70	3864	7728
5-11/16	7.19	18.06	36.12	51.36	102.70	17	64.20	482.30	964.70	4100	8200
5-3/4	7.35	18.66	37.33	53.66	107.30	17-1/4	66.10	503.90	1008	4346	8693
5-13/16	7.51	19.28	38.56	56.03	112.10	17-1/2	68.10	526.20	1052	4604	9208
5-7/8	7.67	19.91	39.82	58.48	117.00	17-3/4	70.00	549.10	1098	4873	9745
5-15/16	7.84	20.55	41.10	61.01	122.00	18	72.00	572.60	1145	5153	10306
6	8.00	21.21	42.41	63.62	127.20	18-1/4	74.00	596.70	1193	5445	10891
6-1/16	8.17	21.88	43.75	66.31	132.60	18-1/2	76.10	621.60	1243	5750	11500
6-1/8	8.34	22.56	45.12	69.09	138.20	18-3/4	78.10	647.10	1294	6067	12134
6-3/16	8.51	23.26	46.51	71.95	143.90	19	80.20	673.40	1347	6397	12794
6-1/4	8.68	23.97	47.94	74.90	149.80	19-1/4	82.40	700.30	1401	6741	13481
6-5/16	8.86	24.69	49.39	77.94	155.90	19-1/2	84.50	728.00	1456	7098	14195
6-3/8	9.03	25.44	50.87	81.08	162.20	19-3/4	86.70	756.30	1513	7469	14937
6-7/16	9.21	26.19	52.38	84.30	168.60	20	88.90	785.40	1571	7854	15708
6-1/2	9.39	26.96	53.92	87.62	175.20	20-1/4	91.10	815.20	1630	8254	16508
6-5/8	9.76	28.55	57.09	94.56	189.10	20-1/2	93.40	845.80	1692	8669	17339
6-3/4	10.10	30.19	60.39	101.90	203.80	20-3/4	95.70	877.10	1754	9100	18200
6-7/8	10.50	31.90	63.80	109.70	219.30	21	98.00	909.20	1818	9547	19093
7	10.90	33.67	67.35	117.90	235.70	21-1/4	100.40	942.10	1884	10009	20019
7-1/8	11.30	35.51	71.02	126.50	253.00	21-1/2	102.70	975.70	1951	10489	20978
7-1/4	11.70	37.41	74.82	135.60	271.20	21-3/4	105.10	1010	2020	10985	21970
7-3/8	12.10	39.38	78.76	145.20	290.40	22	107.60	1045	2091	11499	22998
7-1/2	12.50	41.42	82.84	155.30	310.60	22-1/4	110.00	1081	2163	12031	24061
7-5/8	12.90	43.52	87.05	165.90	331.90	22-1/2	112.50	1118	2237	12581	25161
7-3/4	13.30	45.70	91.40	177.10	354.20	22-3/4	115.00	1156	2312	13149	26298
7-7/8	13.80	47.95	95.89	188.80	377.60	23	117.60	1194	2389	13737	27473
8	14.30	50.27	100.50	201.10	402.10	23-1/4	120.10	1234	2468	14344	28687
8-1/8	14.70	52.66	105.30	213.90	427.90	23-1/2	122.70	1274	2548	14971	29941
8-1/4	15.10	55.13	110.30	227.40	454.80	23-3/4	125.40	1315	2630	15618	31236
8-3/8	15.60	57.67	115.30	241.50	483.00	24	128.00	1357	2714	16286	32572
8-1/2	16.10	60.29	120.60	256.20	512.50	24-1/4	130.70	1400	2800	16975	33951
8-5/8	16.50	62.99	126.00	271.60	543.30	24-1/2	133.40	1444	2888	17686	35372
8-3/4	17.00	65.77	131.60	287.70	575.50	24-3/4	136.20	1488	2977	18419	36838
8-7/8	17.50	68.63	137.30	304.50	609.10	25	138.90	1534	3068	19175	38350
9	18.00	71.57	143.10	322.10	644.10	25-1/4	141.70	1580	3161	19954	39907
9-1/8	18.50	74.59	149.20	340.30	680.70	25-1/2	144.50	1628	3256	20755	41511
9-1/4	19.00	77.70	155.40	359.40	718.70	25-3/4	147.40	1676	3352	21581	43163
9-3/8	19.50	80.89	161.80	379.20	758.40	26	150.30	1726	3451	22432	44864
9-1/2	20.10	84.17	168.30	399.80	799.60	26-1/4	153.20	1776	3552	23307	46614
9-5/8	20.60	87.54	175.10	421.30	842.60	26-1/2	156.10	1827	3654	24208	48415
9-3/4	21.10	90.99	182.00	443.60	887.20	26-3/4	159.00	1879	3758	25134	50268
9-7/8	21.70	94.54	189.10	466.80	933.60	27	162.00	1932	3865	26087	52174
10	22.20	98.17	196.30	490.90	981.70	27-1/2	168.10	2042	4083	28074	56148
10-1/4	23.40	105.72	211.40	541.80	1084	28	174.30	2155	4310	30172	60344
10-1/2	24.50	113.65	227.30	596.70	1193	28-1/2	180.50	2273	4545	32385	64771
10-3/4	25.70	121.96	243.90	655.50	1311	29	186.90	2394	4789	34719	69437
11	26.90	130.67	261.30	718.70	1437	29-1/2	193.40	2520	5041	37176	74351
11-1/4	28.10	139.78	279.60	786.30	1573	30	200.00	2651	5301	39761	79522
11-1/2	29.40	149.31	298.60	858.50	1717	30-1/2	206.80	2785	5571	42479	84957
11-3/4	30.70	159.26	318.50	935.70	1871	31	213.60	2925	5849	45333	90666
12	32.00	169.65	339.30	1018	2036	31-1/2	220.50	3069	6137	48329	96659
12-1/4	33.40	180.47	360.90	1105	2211	32	227.60	3217	6434	51472	102944
12-1/2	34.70	191.75	383.50	1198	2397	32-1/2	234.80	3370	6740	54765	109530
12-3/4	36.10	203.48	407.00	1297	2594	33	242.10	3528	7056	58214	116428
13	37.60	215.69	431.40	1402	2804	34	256.90	3859	7717	65597	131194
13-1/4	39.00	228.37	456.70	1513	3026	35	272.30	4209	8418	73662	147324

Viscosity Classification Equivalents

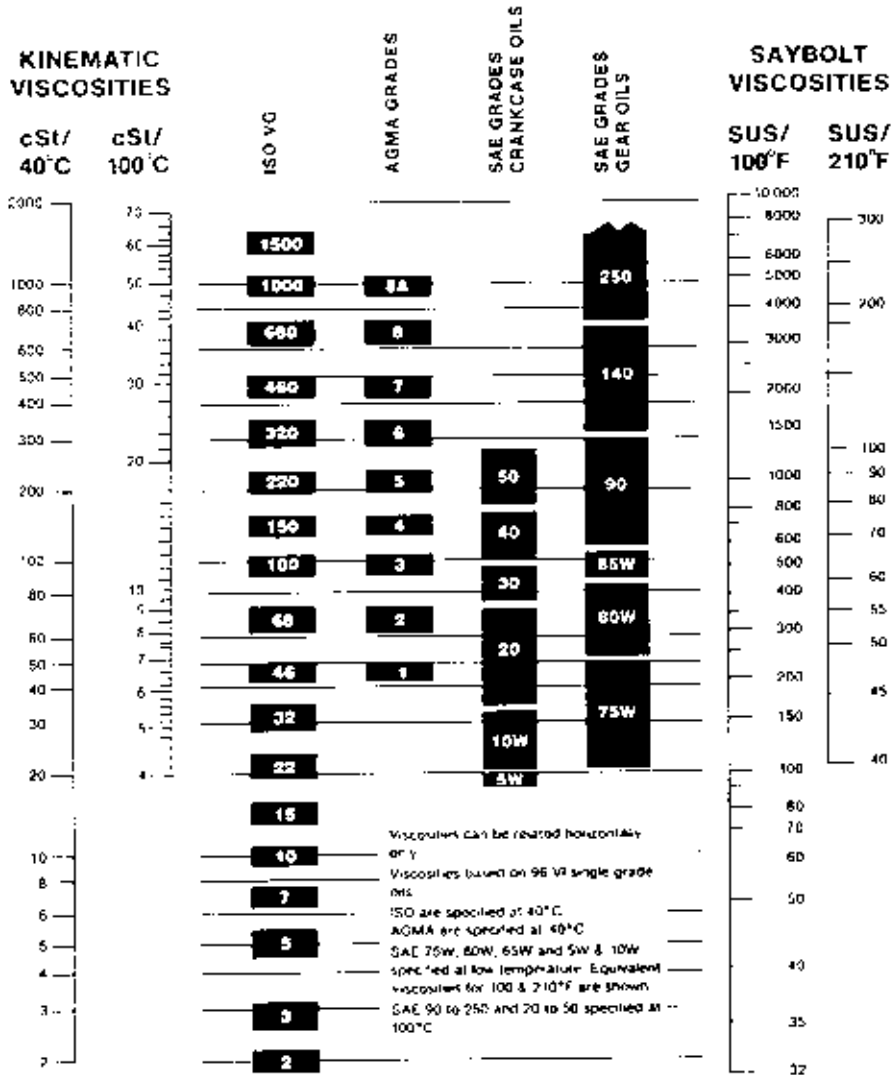

ISO VISCOSITY CLASSIFICATION SYSTEM

All industrial oils are graded according to the ISO Viscosity Classification System, approved by the International Standards Organizations (ISO). Each ISO viscosity grade number corresponds to the mid-point of viscosity range expressed in centistokes (cSt) at 40°C. For example, a lubricant with an ISO grade of 32 has a viscosity within the range of 28.80-35.2, the midpoint of which is 32.

Rule-of-Thumb: The comparable ISO grade of a competitive product whose viscosity in SUS at 100°F is known can be determined by using the following conversion formula:

$$\text{SUS @ 100°F} \div 5 = \text{cSt @ 40°C}$$

ENGINEERING/TECHNICAL



English Standard Measures

Long Measure

- 1 mile = 1760 yards = 5280 feet.
- 1 yard = 3 feet = 36 inches.
- 1 foot = 12 inches.

Surveyor's Measure

- 1 mile = 8 furlongs = 80 chains.
- 1 furlong = 10 chains = 220 yards.
- 1 chain = 4 rods = 22 yards = 66 feet = 100 links.
- 1 link = 7.92 inches.

Square Measure

- 1 square mile = 640 acres = 6400 square chains.
- 1 acre = 10 square chains = 4840 square yards = 43,560 square feet.
- 1 square chain = 16 square rods = 484 square yards = 4356 square feet.
- 1 square rod = 30.25 square yards = 272.25 square feet = 625 square links.
- 1 square yard = 9 square feet.
- 1 square foot = 144 square inches.
- An acre is equal to a square, the side of which is 208.7 feet.

Dry Measure

- 1 bushel (U.S. or Winchester struck bushel) = 1.2445 cubic foot = 2150.42 cubic inches.
- 1 bushel = 4 pecks = 32 quarts = 64 pints.
- 1 peck = 8 quarts = 16 pints.
- 1 quart = 2 pints.
- 1 heaped bushel = 1 1/4 struck bushel.
- 1 cubic foot = 0.8036 struck bushel.
- 1 British Imperial bushel = 8 Imperial gallons = 1.2837 cubic foot = 2218.19 cubic inches.

Liquid Measure

- 1 U.S. gallon = 0.1337 cubic foot = 231 cubic inches = 4 quarts = 8 pints.
- 1 quart = 2 pints = 8 gills.
- 1 pint = 4 gills.
- 1 British Imperial gallon = 1.2003 U.S. gallon = 277.27 cubic inches.
- 1 cubic foot = 7.48 U.S. gallons.

Circular and Angular Measure

- 60 seconds (") = 1 minute (')
- 60 minutes = 1 degree (°)
- 360 degrees = 1 circumference (C)
- 57.3 degrees = 1 radian
- 2 π radians = 1 circumference (C)

Specific Gravity

- The specific gravity of a substance is its weight as compared with the weight of an equal bulk of pure water.
- For making specific gravity determinations the temperature of the water is usually taken at 62° F. when 1 cubic foot of water weighs 62.355 lbs. Water is at its greatest density at 39.20° F. or 4° Centigrade.

Temperature

The following equation will be found convenient for transforming temperature from one system to another:

Let F = degrees Fahrenheit; C = degrees Centigrade; R = degrees Reamur.

$$\frac{F-32}{180} = \frac{C}{100} = \frac{R}{80}$$

Avoirdupois or Commercial Weight

- 1 gross or long ton = 2240 pounds.
- 1 net or short ton = 2000 pounds.
- 1 pound = 16 ounces = 7000 grains.
- 1 ounce = 16 drams = 437.5 grains.

Measures of Pressure

- 1 pound per square inch = 144 pounds per square foot = 0.068 atmosphere = 2.042 inches of mercury at 62 degrees F. = 27.7 inches of water at 62 degrees F. = 2.31 feet of water at 62 degrees F.
- 1 atmosphere = 30 inches of mercury at 62 degrees F. = 14.7 pounds per square inch = 2116.3 pounds per square foot = 33.95 feet of water at 62 degrees F.
- 1 foot of water at 62 degrees F. = 62.355 pounds per square foot = 0.433 pound per square inch.
- 1 inch of mercury at 62 degrees F. = 1.132 foot of water = 13.58 inches of water = 0.491 pound per square inch.
- Column of water 12 in. high, 1 in. dia. = .341 lbs.

Cubic Measure

- 1 cubic yard = 27 cubic feet.
- 1 cubic foot = 1728 cubic inches.
- The following measures are also used for wood and masonry: 1 cord of wood = 4 X 4 X 8 feet = 128 cubic feet.
- 1 perch of masonry = 16-1/2 X 1-1/2 X 1 foot = 24-3/4 cubic feet.

Shipping Measure

- For measuring entire internal capacity of a vessel: 1 register ton = 100 cubic feet.
- For measurement of cargo: 1 U.S. shipping ton = 40 cubic feet = 32.143 U.S. bushels = 31.16 Imperial bushels.
- British shipping ton = 42 cubic feet = 33.75 U.S. bushels = 32.72 Imperial bushels.

Troy Weight, Used for Weighing Gold and Silver

- 1 pound = 12 ounces = 5760 grains.
- 1 ounce = 20 pennyweights = 480 grains.
- 1 pennyweight = 24 grains.
- 1 carat (used in weighing diamonds) = 3.086 grains.
- 1 grain Troy = 1 grain avoirdupois = 1 grain apothecaries' weight.

Measure Used for Diameters and Areas of Electric Wires

- 1 circular inch = area of circle 1 inch in diameter = 0.7854 square inch.
- 1 circular inch = 1,000,000 circular mils.
- 1 square inch = 1.2732 circular inch = 1,273,239 circular mils.
- A circular mil is the area of a circle 0.001 inch in diameter.

Board Measure

- One foot board measure is a piece of wood 12 inches square by 1 inch thick, or 144 cubic inches. 1 cubic foot therefore equals 12 feet board measure.

Table 28: Decimal and Millimeter Equivalents of Fractions

Inches			Milli- meters	Inches			Milli-meters	Inches			Milli-meters
Fractions	Decimals			Fractions	Decimals			Fractions	Decimals		
1/64		.015625	.397		11/32	.34375	8.7319		11/16	.6875	17.463
	1/32	.03125	.794	23/64		.359375	9.128	45/64		.703125	17.859
		.046875	1.191		3/8	.375	9.525		23/32	.71875	18.256
	1/16	.0625	1.588	25/64		.390625	9.922	47/64		.734375	18.653
5/64		.078125	1.984		13/32	.40625	10.319		3/4	.750	19.050
	3/32	.09375	2.381	27/64		.421875	10.716	49/64		.765625	19.447
7/64		.109375	2.778		7/16	.4375	11.113		25/32	.78125	19.844
	1/8	.125	3.175	29/64		.453125	11.509	51/64		.796875	20.241
9/64		.140625	3.582		15/32	.46875	11.906		13/16	.8125	20.638
	5/32	.15625	3.969	31/64		.48376	12.303	53/64		.828125	21.034
11/64		.171875	4.366		1/2	.500	12.700		27/32	.84375	21.431
	3/16	.1875	4.763	33/64		.515625	13.097	55/64		.859375	21.828
13/64		.203125	5.159		17/32	.53125	13.494		7/8	.875	22.225
	7/32	.21875	5.556	35/64		.546875	13.891	57/64		.890625	22.622
15/64		.234375	5.953		9/16	.5625	14.288		29/32	.90524	23.019
	1/4	.250	6.350	37/64		.578125	14.684	59/64		.921875	23.416
7/64		.265625	6.747		19/32	.59375	14.081		15/16	.9375	23.813
	9/32	.28125	7.144	39/64		.609375	15.478	61/64		.953125	24.209
19/64		.296875	7.541		5/8	.625	15.875		31/32	.96875	24.606
	5/16	.3125	7.938	41/64		.640625	16.272	63/64		.984375	25.003
21/64		.328125	8.334		21/32	.65625	16.669		1	1.000	25.400
				43/64		.671875	17.066				

Table 29: Millimeter-Inch Equivalents: 1" = 25.4mm (.03937" = 1mm)

Milli-meter	Decimal	Milli-meter	Decimal	Milli-meter	Decimal	Milli-meter	Decimal	Milli-meter	Decimal
1	.03937	52	2.04724	103	4.05511	154	6.06299	205	8.07086
2	.07874	53	2.08661	104	4.09448	155	6.10236	206	8.11023
3	.11811	54	2.12598	105	4.13385	156	6.14173	207	8.14960
4	.15748	55	2.16535	106	4.17322	157	6.18110	208	8.18897
5	.19685	56	2.20472	107	4.21259	158	6.22047	209	8.22834
6	.23622	57	2.24409	108	4.25196	159	6.25984	210	8.26771
7	.27559	58	2.28346	109	4.29133	160	6.29921	211	8.30708
8	.31496	59	2.32283	110	4.33070	161	6.33858	212	8.34645
9	.35433	60	2.36220	111	4.37007	162	6.37795	213	8.38582
10	.39370	61	2.40157	112	4.40944	163	6.41732	214	8.42519
11	.43307	62	2.44094	113	4.44881	164	6.45669	215	8.46456
12	.47244	63	2.48031	114	4.48818	165	6.49606	216	8.50393
13	.51181	64	2.51968	115	4.52755	166	6.53543	217	8.54330
14	.55118	65	2.55905	116	4.56692	167	6.57480	218	8.58267
15	.59055	66	2.59842	117	4.60629	168	6.61417	219	8.62204
16	.62992	67	2.63779	118	4.64566	169	6.65354	220	8.66141
17	.66929	68	2.67716	119	4.68503	170	6.69291	221	8.70078
18	.70866	69	2.71653	120	4.72440	171	6.73228	222	8.74015
19	.74803	70	2.75590	121	4.76378	172	6.77165	223	8.77952
20	.78740	71	2.79527	122	4.80315	173	6.81102	224	8.81889
21	.82677	72	2.83464	123	4.84252	174	6.85039	225	8.85826
22	.86614	73	2.87401	124	4.88189	175	6.88976	226	8.89763
23	.90551	74	2.91338	125	4.92126	176	6.92913	227	8.93700
24	.94488	75	2.95275	126	4.96063	177	6.96850	228	8.97637
25	.98425	76	2.99212	127	5.00000	178	7.00787	229	9.01574
26	1.02362	77	3.03149	128	5.03937	179	7.04724	230	9.05511
27	1.06299	78	3.07086	129	5.07875	180	7.08661	231	9.09448
28	1.10236	79	3.11023	130	5.11811	181	7.12598	232	9.13385
29	1.14173	80	3.14960	131	5.15749	182	7.16535	233	9.17322
30	1.18110	81	3.18897	132	5.19685	183	7.20472	234	9.21259
31	1.22047	82	3.22834	133	5.23622	184	7.24409	235	9.25196
32	1.25984	83	3.26771	134	5.27559	185	7.28346	236	9.29133
33	1.29921	84	3.30708	135	5.31496	186	7.32283	237	9.33070
34	1.33858	85	3.34645	136	5.35433	187	7.36220	238	9.37007
35	1.37795	86	3.38582	137	5.39370	188	7.40157	239	9.40944
36	1.41732	87	3.42519	138	5.43307	189	7.44094	240	9.44881
37	1.45669	88	3.46456	139	5.47244	190	7.48031	241	9.48818
38	1.49606	89	3.50393	140	5.51181	191	7.51968	242	9.52755
39	1.53543	90	3.54330	141	5.55118	192	7.55905	243	9.56692
40	1.57480	91	3.58267	142	5.59055	193	7.59842	244	9.60629
41	1.61417	92	3.62204	143	5.62992	194	7.63779	245	9.64566
42	1.65354	93	3.66141	144	5.66929	195	7.67716	246	9.68503
43	1.69291	94	3.70078	145	5.70866	196	7.71653	247	9.72440
44	1.73228	95	3.74015	146	5.74804	197	7.75590	248	9.76378
45	1.77165	96	3.77952	147	5.78740	198	7.79527	249	9.80315
46	1.81102	97	3.81889	148	5.82677	199	7.83464	250	9.84252
47	1.85039	98	3.85826	149	5.86614	200	7.87401	251	9.88189
48	1.88976	99	3.89763	150	5.90551	201	7.91338	252	9.92126
49	1.92913	100	3.93710	151	5.94488	202	7.95275	253	9.96063
50	1.96850	101	3.97637	152	5.98425	203	7.99221	254	10.00000
51	2.00787	102	4.01574	153	6.02362	204	8.03149	-	-

ENGINEERING/TECHNICAL



Metric System of Measurements

Measures of Length

10	millimeters (mm.)	=	1 centimeter (cm.)
10	centimeters	=	1 decimeter (dm.)
10	decimeters	=	1 meter (m.)
1000	meter	=	1 kilometer (km.)

Measure of Weight

10	milligrams (mg.)	=	1 centigram (cg.)
10	centigrams	=	1 decigram (dg.)
10	decigrams	=	1 gram (g.)
10	grams	=	1 decagram (Dg.)
10	decagrams	=	1 hectogram (Hg.)
10	hectograms	=	1 Kilogram (Kg.)
1000	kilograms	=	1 (metric) ton (T.)

Surveyor's Square Measure

100	square meters (m. ²)	=	1 are (ar.)
100	acres	=	1 hectare (har.)
100	hectares	=	1 sq. kilometer (Km. ²)

Millimeters X.039370 = inches.
Meters x 39.370 = inches.
Meters X 3.2808 = feet.
Meters X 1.09361 = yards.
Kilometers X 3,280.8 = feet.
Kilometers X.62137 = Statute Miles.
Kilometers x.53959 = Nautical Miles.

Grams X 981 = dynes.
Grams X 15.432 = grains.
Grams X.03527 = ounces (Avd.).
Grams x.033818 = fluid ounces (water).
Kilograms X 35.27 = ounces (Avd.).
Kilograms X 2.20462 = pounds (Avd.).
Metric Tons (1000 Kg.) X 1.10231 = Net Ton (2000 lbs.).
Metric Tons (1000 Kg.) X.98421 = Gross Ton (2240 lbs.).

Square Millimeters X.00155 = square inches.
Square centimeters X.155 = square inches.
Square Meters X 10.76387 = square feet.
Square Meters X 1.19599 = square yards.
Hectares X 2.47104 = acres.
Square Kilometers X 247.104 = acres.
Square Kilometers X.3861 = square miles.

Cubic centimeters X.033818 = fluid ounces.
Cubic centimeters X.061023 = cubic inches.
Cubic centimeters X.271 = fluid drams.
Liters X 61.023 = cubic inches.
Liters X 1.05668 = quarts.
Liters X .26417 = gallons.
Liters X.035317 = cubic feet.
Hectoliters X 26.417 = gallons.
Hectoliters X 3.5317 = cubic feet.
Hectoliters X 2.83794 = bushel (2150.42 cu. in.).
Hectoliters X.1308 = cubic yards.
Cubic Meters x 264.17 = gallons.
Cubic Meters x 35.317 = cubic feet.
Cubic Meters X 1.308 = cubic yards.

Calorie x 0.003968 = B. T.U.
Joules X.7373 = pound-feet.
Newton-Meters X 8.851 = pound-inches
Cheval Vapeur X.9863 = Horsepower.
Kilowatts X 1.34 = Horsepower.
Kilowatt Hours X 3415 = B.T.U.
(Degrees Cent. X 1.8) + 32 = degrees Fahr.
(Degrees Reamur X 2.25) + 32 = degrees Fahr.

Square Measure

100	sq. millimeters (mm. ²)	=	1 sq. centimeter (cm. ²)
100	sq. centimeters	=	1 sq. decimeter (dm. ²)
100	sq. decimeters	=	1 sq. meter (m. ²)

Cubic Measure

1000	cu. millimeters (mm. ³)	=	1 cu. centimeter (cm. ³)
1000	cu. centimeters	=	1 cu. decimeter (dm. ³)
1000	cu. decimeters	=	1 cu. meter (m. ³)

Dry and Liquid Measure

10	milliliters (ml.)	=	1 centiliter (cl.)
10	centiliters	=	1 deciliter (dl.)
10	deciliters	=	1 liter (l.)
100	liters	=	1 hectoliter (Hl.)

1 liter = 1 cubic decimeter = the volume of 1 kilogram of pure water at a temperature of 39.2 degrees F.

Length Conversion Constants for Metric and U.S. Units

Inches X 25.4001 = millimeters.
Inches X.0254 = meters.
Feet x.30480 = meters.
Yards X.91440 = meters.
Feet x.0003048 = kilometers.
Statute Miles X 1.60935 = kilometers.
Nautical Miles x 1.85325 = kilometers.

Weight Conversion Constants for Metric and U.S. Units

Dynes X.0010193 = grams.
Grains X.0648 = grams.
Ounces (Avd.) X 28.35 = grams.
Fluid Ounces (Water) X 29.57 = grams.
Ounces (Avd.) X.02835 = kilograms.
Pounds (Avd.) X.45359 = kilograms.
Net Ton (2000 lbs.) X.90719 = Metric Tons (1000 Kg.).
Gross Ton (2240 lbs.) X 1.01605 = Metric Tons (1000 Kg.).

Area Conversion Constants for Metric and U.S. Units

Square Inches X 645.163 = square millimeters.
Square Inches x 6.45163 = square centimeters.
Square Feet x.0929 = square meters.
Square Yards X.83613 = square meters.
Acres X.40469 = hectares.
Acres X.0040469 = square kilometers.
Square Miles X 2.5899 = square kilometers.

Volume Conversion Constants for Metric and U.S. Units

Fluid Ounces X 29.57 = cubic centimeters.
Cubic Inches X 16.387 = cubic centimeters.
Fluid Drams x 3.69 = cubic centimeters.
Cubic Inches X.016387 = liters.
Quarts x.94636 = liters.
Gallons x 3.78543 = liters.
Cubic Feet x 28.316 = liters.
Gallons x.0378543 = hectoliters.
Cubic Feet x.28316 = hectoliters.
Bushels (2150.42 cu. in.) X.352379 = hectoliters.
Cubic Yards x 7.645 = hectoliters.
Gallons x.00378543 = cubic meters.
Cubic Feet x.028316 = cubic meters.
Cubic Yards x.7645 = cubic meters.

Power and Heat Conversion Constants for Metric and U.S. Units

B.T.U. X 252 = calories.
Pound-Foot X 1.3563 = joules.
Pound-inches X.11298 = Newton-meters.
Horsepower X 1.014 = Cheval Vapeur.
Horsepower X.746 = kilowatts.
B.T.U. X.00029282 = kilowatt hours.
(Degrees Fahr. - 32) x.555 = degrees Cent.
(Degrees Fahr. - 32) x.444 = degrees Reamur.

COMMON CONVERSION FACTORS USEFUL IN MECHANICAL POWER TRANSMISSION

Symbols and Abbreviations Used in Conversion Factors

Symbols and abbreviations found in this section are those currently used in many texts and product publications. Considerable effort is underway to standardize on abbreviations for metric and English units of measurement. Recently, ASTM (American Society for Testing and Materials) and IEEE (Institute of Electrical and Electronic Engineers) published a standard practice on the metric system. † This publication consolidates a great deal of the current thinking and provides a system of abbreviations and symbols that differ somewhat from those used here.

This Handbook has retained use of familiar abbreviations consistent with existing product and trade literature rather than the abbreviations found in current publications of technical and scientific societies.

Prefixes Used in the Metric System

Common prefixes and symbols used in the metric system are listed below. An example of use is 1000 meters is equivalent to 1 kilometer, and 1/1000 of one meter is equivalent to 1 millimeter.

Prefix	Symbol	Multiplication Factor-Decimal and Power of 10
giga	G	1,000,000,000 or 10^9 or one billion
mega	M	1,000,000 or 10^6 or one million
kilo	k	1,000 or 10^3 or one thousand
*hecto	h	100 or 10^2 or one hundred
*deka	da	10 or 10^1 or ten
**deci	d	0.1 or 10^{-1} or one tenth
**centi	c	0.01 or 10^{-2} or one hundredth
mill	m	0.001 or 10^{-3} or one thousandth
micro	μ	0.000,001 or 10^{-6} or one millionth
nano	n	0.000,000,001 or 10^{-9} or one billionth

* Not commonly used.

** Not commonly used except for special situations.

The centimeter as a unit of length is in common use.

The decibel is a unit in both electrical and acoustical work.

†ASTM/IEEE Standard Metric Practice, ASTM E 380-75, IEEE Std. 268-1976.

“Reprinted with Permission of the Power Transmission Distributors Association”

ENGINEERING/TECHNICAL



Symbol or Abbreviation	Term
atm	atmosphere
avdp	avoirdupois
bbl	barrels
bu	bushels
C	degrees Centigrade or Celsius
cc	cubic centimeters
cfm	cubic feet per minute
cfs	cubic feet per second
cm	centimeter
cu	cubic
deg	degrees
F	degrees Fahrenheit
fps	feet per second
ft	feet
ft-lb	foot-pounds (work or energy)
ft per sec	feet per second (alternate)
ft per sec ²	feet per second per second
g	acceleration due to gravity
g	grams
gal	gallons
gpm	gallons per minute
hp	horsepower
hr	hour
in	inches
in-lb	inch-pounds (work or energy)
K	degrees Kelvin
kg	kilograms
km	kilometers
kn	knots
KW	kilowatts

Symbol or Abbreviation	Term
l	liters
lb	pounds
lb-ft	pound-feet (torque)
m	meters
m per sec ²	meters per second per second
mi	miles
mm	millimeters
mph	miles per hour
MGD	millions of gallons per day
N	Newtons
oz	ounces
oz-in	ounce-inches (torque)
Pa	Pascals
psi	pounds per square inch
psia or psig	pounds per square inch "absolute" or gauge
pt	pint
qt	quart
R	degrees Rankine (Fahrenheit, absolute)
rad	radians
rev	revolutions
rpm	revolutions per minute
sec	seconds
sq	square
std	standard
temp	temperature
wt	weight
yd	yard
yr	year

Rounding of Numbers

A minimum of four significant figures are used in conversion factors presented here. Where the conversion factor is exact (for example, 1 foot contains 12 inches), decimal fractions are not necessary. Also, where large whole numbers are used (for example, 1 square kilometer contains 1195990 square yards), decimal fractions are not used unless justified by the accuracy of ordinary computations.

1195990	(sq yd in a sq km)
4389.12	(cc in a cu ft)
448.86	(gpm in a liter per sec)
14.70	(psi in an atmosphere)
0.4331	(psi in a ft of water)
0.0625	(lb-in in an oz-in)

VELOCITY

centimeters per second (cm per sec)	feet per second (fps or ft per sec)	0.3281
feet per second (fps)	centimeters per second (cm per sec).	30.48
	meters per second (m per sec)	0.3048
	kilometers per hour (km per hr)	1.097
	miles per hour (mph)	0.6818
kilometers per hour (km per hr).	knots (kn)	0.5396
	feet per second (fps)	1.467
	kilometers per hour (km per hr)	1.609
	feet per minute (ft per min.)	88
knots (kn)	miles per hour (mph)	1.152
	kilometers per hour (km per hr)	1.853
radians per second (rad per sec)	revolutions per minute (rpm)	9.55
	degrees per minute (deg per min.)	3437.7
revolutions per minute (rpm)	radians per second (rad per sec)	0.1047
	degrees per minute (deg per min.)	360

ACCELERATION

COLUMN A

To Convert From...	To...	Multiply Col. A by
feet per second per second (ft per sec ²)	meters per second per second (m per sec ²)	0.3048
m per sec ²	ft per sec ²	3.281
revolutions per minute per second (rpm per sec)	radians per second per second (rad per sec ²)	0.1047
rad per sec ²	rpm per sec	9.55

ENGINEERING/TECHNICAL



VOLUMETRIC FLOW RATES

gallons per minute, US (gpm)	liters per second (l per sec)	0.008434
	cubic feet per minute (cfm)	0.1337
	cubic feet per hour (cu ft per hr)	8.022
gallons per minute, UK or Canadian (gpm)	liters per second (l per sec)	0.0101
	cubic feet per minute (cfm)	0.1606
	cubic feet per hour (cu ft per hr)	9.634
cubic feet per second (cfs)	gpm (UK or Canadian)	373.77
	gpm (US)	448.86
	liters per second (l per sec)	1699.2
liters per second (l per sec)	cubic feet per minute (cfm)	2.119
	gpm (UK or Canadian)	13.20
	gpm (US)	15.85
millions of gallons per day, US (MGD)	liters per second (l per sec)	43.81
	cubic feet per minute (cfm)	92.85
	gallons per minute, US (gpm)	694.44

PRESSURE

pascals (Pa)	pounds per square inch (psi)	0.0001450
	pounds per square foot (lb per ft ²)	0.02089
	newtons per square meter	1
pounds per square inch (psi)	atmospheres, std. (atm)	0.0680
	pounds per square foot (lb per ft ²)	144
	pascals (Pa)	6894.8
	foot of water (ft of H ₂ O) 60F	2.301
atmospheres (atm), standard	psi	14.70
	lb per ft ²	2116.8
	Pa	101325
inch of water, 60F (in of H ₂ O)	psi	0.03609
	lb per ft ²	5.197
	Pa	248.84
foot of water, 60F (ft of H ₂ O)	psi	0.4331
	lb per ft ²	62.36
	Pa	2985.9

WEIGHT, MASS, INERTIA

pounds (lb)*	kilograms (kg)	0.4536
	ounces (oz)	16
kilograms (kg)	pounds (lb)	2.205
	ounces (oz)	35.27

WEIGHT, MASS, INERTIA, continued

COLUMN A

Convert From...	To	Multiply To Col. A by
tons (short)	metric tons	0.9072
	kilograms (kg)	907.2
	pounds (lb)	2000
metric tons	tons (short)	1.102
	kilograms	1000
	pounds	2205
pounds, weight (lb)	slugs, mass (lb-sec ² per ft)	0.03106
pound-foot ² (lb-ft ²)	kilogram-meters ² (kg-m ²)	0.04214
*pounds and ounces are avoirdupois		

FORCE AND TORQUE

pounds (lb)	newtons(N)	4.448
newtons (N)	pounds (lb)	0.2248
newton-meters (N-m)	pound-feet (lb-ft)	0.7376
	pound-inches (lb-in)	8.851
	ounce-inches (oz-in)	141.60
ounce-inches (oz-in)	lb-ft	0.005208
	N-m	0.007062
	lb-in	0.0625
pound-inches (lb-in)	lb-ft	0.0833
	N-m	0.1298
	oz-ln	16
pound-feet (lb-ft)	N-m	1.356
	lb -in	12
	oz-ln	192

POWER

horsepower (hp)	kilowatts (kW)	0.7457
	foot-pounds per second (ft-lb per sec)	550
	foot-pounds per minute (ft-lb per min.)	33000
kilowatts (kW)	horsepower (hp)	1.341

TEMPERATURE

		Use This Relationship
degrees Fahrenheit (F)	degrees Celsius (C)	C =5/9 (F-32)
degrees Celsius (C)	degrees Fahrenheit (F)	F=9/5C+32
degrees Fahrenheit (F)	degrees Rankine (R)	R =F+459.69
degrees Celsius (C)	degrees Kelvin (K)	K=C+273.16

Examples:

- Convert 12F to C. $C = 5/9 (F-32) = 5/9 (12-32) = 5/9 (-20)$
Answer = -11.1C
- Convert 40C to F. $F = 9/5C + 32 = 9/5 (40) + 32 = 72 + 32$
Answer = 104F



GRAVITATIONAL CONSTANT

g = 32.174 feet per second per second (ft per sec²)
 = 9.8067 meters per second per second (m per sec²)

APPROXIMATE DENSITIES OF COMMON MATERIALS

REPRESENTATIVE DENSITIES

Grams per cc lb per cu ft

GASES @ 68F, std atm

Air	1.30 grams per liter	0.07528
Oxygen	1.45 grams per liter	0.08305
Hydrogen	0.09 grams per liter	0.005234
Nitrogen	1.25 grams per liter	0.07274
	All Other Materials	
	grams per cc	

LIQUIDS

Water @ 4C	1.000 grams per cc	62.43
20C	0.998	62.32
40C	0.992	61.94
SeaWater	1.02-1.03	64.00
Ethyl alcohol 100%	0.789	49.2
Kerosene	0.78-0.82	50
Gasoline	0.70-0.75	45

METALS

Aluminum (95% Al)	2.70	169
Bronze (90% Cu, 10% Zn)	8.80	549
Copper (Annealed, ACS)	8.89	555
Gold	19.32	1206
Iron, gray cast	7.10	443
Lead	11.36	709
Magnesium	1.74	109
Steel (0.4-0.5%Carbon)	7.80	487
Steel, 410 stainless	7.70	480

ENGINEERING PLASTICS

ABS, general purpose	1.01-1.05	64
Acrylics, cast sheet	1.19	74
Nylon 6/6	1.13-1.15	71
Phenolic, general purpose	1.35-1.46	87
Polycarbonates, general purpose	1.2	75
Polyesters, thermoplastic, unreinforced	1.31 - 1.43	86
Polyethylene, medium density	0.926-0.940	58
Polyvinyl Chloride	1.30-1.58	89

APPROXIMATE DENSITIES OF COMMON MATERIALS

	REPRESENTATIVE DENSITIES	
	Grams per cc	lb per cu ft
OTHER MATERIALS		
Concrete (stone and sand)	2.2-2.4	144
Limestone	1.5	94
Anthracite coal, not piled.	1.4-1.8	100
Bituminous coal, not piled.	1.2-1.5	83
Lignite coal, not piled	1.1-1.4	78
Wood, air dried:		
Douglas fir.	0.48-0.55	32
White oak	0.77	48
White maple	0.53	33
Oregon pine	0.51	32
Hickory	0.74-0.80	48
Mahogany	0.56-0.85	44
African teak.	0.99	62
Indian teak	0.66-0.88	48

Formulas and Constants

- 1 HP = 33,000 Foot-pounds of work per minute.
- 1 HP = .746 K.W. = K.W.P 1.341.
- 1 HP = 2547 B.T.U. per hour.
- 1 B.T.U. = Heat required to raise 1 lb. water 1°F.
- 1 B.T.U. = 777.6 Foot-pounds work.
- 1 Kilowatt Hour = 3415 B.T.U.
- Heat Value of Carbon = 14,600 B.T.U. per pound.
- Latent Heat of Fusion of Ice = 143.15 B.T.U. per pound.
- Latent Heat of Evaporation of Water at 212°F. = 970.4 B.T.U. per pound.
- Total Heat of Saturated Steam at atmospheric pressure = 1,150.4 B.T.U. per pound.
- 1 Ton of Refrigeration = 288,000 B.T.U. per 24 hours.
- g = Acceleration of Gravity (commonly taken as 32.16 feet per second per second).
- 1 Radian = 57.296 degrees.
- 1 Meter = 100 cm. = 39.37 inches.

- 1 Kilometer = .62137 miles.
- 1 Gallon = 231 cubic inches.
- 1 Barrel = 31.5 gallons.
- Atmospheric Pressure = 14.7 pounds per sq. in. = 29.92 inches mercury at 32°F.
- 1 Lb. per Sq. In. Pressure = 2.3095 feet fresh water at 62°F. = 2.0355 inches mercury at 32°F. = 2.0416 inches mercury at 62°F.
- Water Pressure (pounds per sq. in.) = .433 X height of water in feet (Fresh water at 62°F.).
- Weight of 1 cu. ft. fresh Water = 62.355 lbs. at 62°F. = 59.76 lbs. at 212°F.
- Weight of 1 cu. ft. Air at 14.7 lbs. per sq. in. Pressure = .07608 lbs. at 62°F. = .08073 lbs. at 32°F.
- † Also look in the General Index under Weights, Measures, or the subject material required.



ENGINEERING/TECHNICAL

Flywheel Formulas

Flywheels are used on some machines, for example air compressors, to even out load pulsations. The following formulas are useful in designing entire flywheels and flywheel rims. A V-belt sheave may also be used as a flywheel eliminating the need for a separate flywheel in the system.

Formulas for Entire Flywheel

Kinetic energy of rotation of a flywheel (foot pounds) = .0001705 N₂(WR₂)^{*}.

Torque to uniformly accelerate or decelerate a flywheel

$$= \frac{.03908 (N_2 - N_1) (WR_2), \text{ * pound-inches}}{t}$$

where N₂ = final R.P.M. and N₁ = initial R.P.M.

Velocity at outside diameter (feet per minute) = 0.2618 ND.

W = weight (pounds).

R = radius of gyration (feet).

N = speed (R.P.M.)

t = time to change from N₁ to N₂ (seconds).

F = face of rim (inches).

D = outside diameter of rim (inches).

d = inside diameter of rim (inches).

K = weight per cubic inch of material (pounds).

*WR² = flywheel effect (pounds X feet²). See table to the right for WR² of rims. Ordinarily the WR² of the rim only is considered. In unusual instances the relatively small WR² values of the hub and arms or web can be added directly to the WR² of the rim if desired. To find the WR² of a hub or web use the WR² formula for rims, substituting the hub or web outside diameter, inside diameter, and width for D, d

and F respectively. When arms are used instead of a web an approximate WR² value of the arms is the total weight of the arms in pounds times the square of the radius in feet from the shaft center line to the mid point of the arms between hub and rim.

Table 30: Formulas for Flywheel Rims

Property	Cast Iron Rim (Based on .26 lbs. per cu. in.)	Steel Rim (Based on .283 lbs. per cu. in.)	Rim of any material weighing K pounds per cubic inch
Volume (Cubic Inches)	.7854F(D ² -d ²)	.7854F(D ² -d ²)	.7854F(D ² -d ²)
W Weight (Pounds)	.2042F(D ² -d ²)	.2223F(D ² -d ²)	.7854FK(D ² -d ²)
R Radius of Gyration (Feet)	$\sqrt{\frac{0.8681(D^2 + d^2)}{1000}}$	$\sqrt{\frac{0.8681(D^2 + d^2)}{1000}}$	$\sqrt{\frac{0.8681(D^2 + d^2)}{1000}}$
WR ² Wt X Sq. of Radius of Gyration (Lbs. X Ft. ²)	$\frac{.1773F(D^4-d^4)}{1000}$	$\frac{.1929F(D^4-d^4)}{1000}$	$\frac{.6818FK(D^4-d^4)}{1000}$
T ▲ Tensile Load in rim (Lbs.)	$\frac{.3078FN_2(D^3-d^3)}{1,000,000}$	$\frac{.3350FN_2(D^3-d^3)}{1,000,000}$	$\frac{1,184FKN_2(D^3-d^3)}{1,000,000}$

▲ Centrifugal force causes this tensile load at each and every section of the rim. Hence, on rims split into two or more sections the fastening at each joint should be designed to take the full load as calculated from the formula here given.

Centrifugal Force

R = Distance from the axis of rotation to the center of gravity of the body (feet).

N = Revolutions per minute.

v = Velocity of the center of gravity of the body (feet per second).

g = Acceleration due to gravity (32.16 commonly).

$$F = \frac{Wv^2}{gR} = \frac{WRN^2}{2933} = .000341 WRN^2$$

F = Centrifugal force tending to move the body outward from the axis of rotation (pounds).

W = Weight of body (pounds).

Torque and Horsepower Equivalents

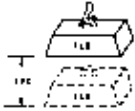

A foot-pound is the amount of energy expended in lifting a one-pound mass a distance of one foot against the pull of gravity

FOOT-POUNDS INDICATE ENERGY

$$\begin{aligned} \text{Torque (in Pound-Inches)} &= \frac{63,025 \times \text{HP}}{\text{RPM}} \\ &= \text{Force} \times \text{Lever Arm (In Inches)} \\ \text{Torque (In Pound-Feet)} &= \frac{5,252 \times \text{HP}}{\text{RPM}} \\ &= \text{Force} \times \text{Lever Arm (In Feet)} \end{aligned}$$

Force = Working Load in Pounds.
 FPM = Feet Per Minute.
 RPM = Revolutions Per Minute.
 Lever Arm = Distance from the Force to the center of rotation in Inches or Feet.

HORSEPOWER
Common Unit of Mechanical power - (HP)
One HP is the rate of work required to raise 33,000 pounds one foot in one minute

TORQUE

It is: a turning moment or twisting effort.
Is it expressed in foot-pounds? or pound-feet?

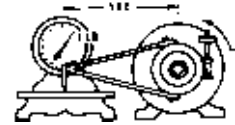

A pound-foot is the moment created by a force of one pound applied to the end of a lever arm one

POUND-FEET INDICATE TORQUE

Example:-

$$\begin{aligned} 25 \text{ HP at } 150 \text{ RPM} &= 10504 \text{ Pound-Inches Torque} \\ 2.5 \text{ HP at } 150 \text{ RPM} &= 1050.4 \text{ Pound-Inches Torque} \end{aligned}$$

For other values of RPM move decimal point in RPM values to the left or right as desired, and in Torque values move to the right or left (opposite way) the same number of places.

Example:-

$$\begin{aligned} 25 \text{ HP at } 150 \text{ RPM} &= 10504 \text{ Pound-Inches Torque} \\ 25 \text{ HP at } 1.50 \text{ RPM} &= 1050400 \text{ Pound-Inches Torque} \\ 2.5 \text{ HP at } 1.50 \text{ RPM} &= 105040 \text{ Pound-Inches Torque} \end{aligned}$$



Overhung Loads

An overhung load is a bending force imposed on a shaft due to the torque transmitted by V-drives, chain drives and other power transmission devices, other than flexible couplings.

Most motor and reducer manufacturers list the maximum values allowable for overhung loads. It is desirable that these figures be compared with the load actually imposed by the connected drive.

Overhung loads may be calculated as follows:

$$\text{O.H.L.} = \frac{63,000 \times \text{HP} \times \text{F}}{\text{N} \times \text{R}}$$

Where HP = Transmitted hp X service factor
 N = RPM of shaft
 R = Radius of sprocket, pulley, etc.
 F = Factor

Weights of the drive components are usually negligible. The formula is based on the assumption that the load is applied at a point equal to one shaft diameter from the bearing face. Factor F depends on the type of drive used:

$$F = \begin{cases} 1.00 & \text{for single chain drives.} \\ 1.3 & \text{for TIMING Belt Drives and HTD belt Drives.} \\ 1.25 & \text{for spur or helical gear or double chain drives.} \\ 1.50 & \text{for V-belt drives. 2.50 for flat belt drives.} \\ 2.50 & \text{for flat belt drives.} \end{cases}$$

Example: Find the overhung load imposed on a reducer by a double chain drive transmitting 7 hp @ 30 RPM. The pitch diameter of the sprocket is 10"; service factor is 1.3.

Solution:

$$\text{O.H.L.} = \frac{(63,000) (7 \times 1.3) (1.25)}{(30) (5)} = 4,780 \text{ lbs.}$$

Mathematical Equations

- To find circumference of a circle, multiply diameter by 3.1416.
- To find diameter of a circle, multiply circumference by .31831.
- To find area of a circle, multiply square of diameter by .7854.
- To find area of a rectangle, multiply length by breadth.
- To find area of a triangle, multiply base by 1/2 perpendicular height.
- To find area of ellipse, multiply product of both diameters by .7854.
- To find area of parallelogram, multiply base by altitude.
- To find side of an inscribed square, multiply diameter by 0.7071 or multiply circumference by 0.2251 or divide circumference by 4.4428.
- To find side of inscribed cube, multiply radius of sphere by 1.1547.

- To find side of an equal square, multiply diameter by .8862.
- To find the surface of a sphere, square the diameter and multiply by 3.1416.
- To find the volume of a sphere, cube the diameter and multiply by .5236.
- A side of a square multiplied by 1.4142 equals diameter of its circumscribing circle.
- A side of a square multiplied by 4.443 equals circumference of its circumscribing circle.
- A side of a square multiplied by 1.128 equals diameter of an equal circle.
- A side of a square multiplied by 3.547 equals circumference of an equal circle.
- To find gallon capacity of tanks (given dimensions of a cylinder in inches): square the diameter of the cylinder, multiply by the length and by .0034.

ENGINEERING/TECHNICAL



Table 31: Strength and Physical Properties of Various Metals

Metals and Alloys	Stress in Thousands of Pounds per Sq. Inch				Modulus of Elasticity Millions of PSI	Elongation%
	Tension Ultimate	Tension Yield Point	Compression Ultimate	Shear Ultimate		
Aluminum, Type 1100-0, Annealed	13	5	9	10	45
Aluminum, Type 1100-H18, Hard	24	22	13	10	15
Aluminum, Type 3003-0, Annealed	16	6	11	10	40
Aluminum, Type 3003-H18, Hard	29	27	16	10	10
Aluminum, Type 5052-0, Annealed	28	13	18	10.20	30
Aluminum, Type 5052-H38, Hard	42	37	24	10.20	8
Aluminum, Type 5056-0, Annealed	42	22	26	10.30	35
Aluminum, Type 2014-0, Annealed	27	14	18	10.60	18
Aluminum, Type 2014-T4, Heat Treated	62	42	38	10.60	20
Aluminum, Type C4A, Casting, Solution Heat Treat	32	16	16▲	24	8.50
Aluminum, Type S5C, As Die Cast	30	16	16▲	19	9
Brass, Admiralty, Annealed	53	22	16	65
Brass, Aluminum, Annealed	60	27	16	55
Brass, Cartridge, 30% Zn, Annealed	44	11	32	16	66
Brass, Cartridge, 30% Zn, Hard	76	63	44	16	8
Brass, Naval, Annealed	57†	25†	40 †	15	47†
Brass, Naval, Leaded, Annealed	57†	25†	36 †	15	40†
Brass, Red, 15% Zn, Annealed	39	10	31	17	48
Brass, Red, 15% Zn, Hard	70	57	42	17	5
Brass, Red, Leaded, Cast, Grade 4A	33-46	17-24	10-12▲	9.1-14.8	20-35
Brass, Red, Leaded, Cast, Grade 4B	30-38	12-17	11-12▲	15-27
Brass, Semi-Red, Leaded, Cast, Grade 5A	29-39	13-17	7.7-14.3	18-30
Brass, Semi-Red, Leaded, Cast, Grade 5B	30-40	12-16	8-10▲	10-14	20-35
Brass, Yellow, 35% Zn, Annealed	46	14	32	15	65
Brass, Yellow, 35% Zn, Hard	74	60	43	15	8
Bronze, Aluminum, As Cast	67-95	27-45	15-18	5-35
Bronze, Commercial, 10% Zn, Annealed	37†	10†	28 †	17	45†
Bronze, Manganese, Annealed	65†	30†	42 †	15	33†
Bronze, Phosphor, Annealed	40-66	14-24	16-17	48-70
Bronze, Tin, High Leaded, Cast	23-38	11-22	12-16▲	8.5-13	7-20
Bronze, Tin, Leaded, Cast	33-48	16-26	9-15s▲	10.6-16	15-40
Copper, Beryllium, Annealed	60-80	25-35†	50-60 †	19	35-50†
Copper, Electrolytic, Tough Pitch, Annealed	32†	10†	22 †	17	45†
Inconel, Cast	65-90	23	10-20
Inconel, S, Cast	90-120	80-100	25	1-3
Inconel, Shapes, Plate, Etc., Annealed	80-100†	30-45†	31	35-55†
Inconel, X, Shapes, Plate, Etc., Annealed	110-130†	45-65†	31	40-55†
Iron, Cast, Class 30	30-34	115	44	15
Iron, Cast, Class 35	35-40	125	43	16
Iron, Ingot, Hot Rolled	44	23	29.80	47
Iron, Malleable, Class 32510	50	33	90	46	25	10-18
Iron, Malleable, Class 35018	55	37	90	51	25	18-25
Iron, Nodular (Ductile) Class 60-45-10	60	45	120	22-25	10-25
Iron, Nodular (Ductile) Class 80-60-3	80	60	160	22-25	3-10
Iron, Pearlitic, Malleable	60-90	40-70	28	3-12
Iron, Wrought, Hot Rolled	34-47	23-24	29	7-35
Lead, Hard, Rolled	4.0-4.6	31-48
Magnesium Alloy, Extruded, ASTM M1A	26-28	23-28	10-13	16	6.50	8-11
Magnesium Alloy, Extruded, ASTM AZ61A-F	40-45	22-32	15-21	21	6.50	15-16
Magnesium Alloy, Cast, ASTM M1B	14	4.50	11	6.50	5
Magnesium Alloy, Cast, ASTM AZ92A	24	14	19	6.50	2
Magnesium Alloy, Cast, ASTM AZ91A	36	23	20	6.50	4
Monel, Cast	65-90	32-45	23	20-50
Monel, S, Cast	120-145	80-130	24.20	1-4
Monel, Shapes, Plate, Etc., Annealed	70-85†	25-45†	26	35-50†
Monel, K, Shapes, Plate, Etc., Annealed	90-105†	40-65†	26	25-45	35-55†
Muntz Metal, Cu 59.63%, Zn balance	54	21	40	15	45
Nickel, Cast	50-65	15-30	21.50	15-30
Nickel, Silver, Annealed	49-63†	18-30†	17-18	35-60†
Steel, Cast Carbon, Class 70,000 Normalized	70	38	30	28
Steel, Cast Low Alloy, Class 100,000, Normalized and Tempered	100	68	29-30	20
Steel, Cast Low Alloy, Class 120,000, Quenched and Tempered	120	95	29-30	16
Steel, Cast Low Alloy, Class 200,000, Quenched and Tempered	200	170	29-30	5
Steel, Sheets	48	25	29-30	18-27
Steel, Stainless, Austenitic, Types 304, 316	85	35	28	55-60
Steel, Stainless, Martensitic, Type 416	75	40	29	30
Steel, Structural, Bridge and Building, ASTM A7	60-72	33	33▲	45-54	29-30	21
Steel, Structural, High Strength, Low Alloy, ASTM A242	63-70	42-50	42-50▲	47-53	29-30	18-24
Zinc, Die Cast Alloy XXIII	41	60▲	31	10

† When hardened, strength values are higher, elongation less

▲ Compression yield point

Table 32: Properties of Sections

A = area
 I = moment of inertia
 J = polar moment of inertia

Z = section modulus π
 k = radius of gyration
 \bar{y} = centroidal distance

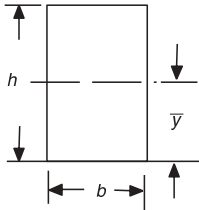
Rectangle

$$A = bh$$

$$k = 0.289h$$

$$I = \frac{bh^3}{12}$$

$$\bar{y} = \frac{h}{2}$$

$$Z = \frac{bh^2}{6}$$

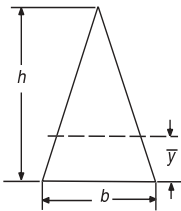
Triangle

$$A = \frac{bh}{2}$$

$$k = 0.236h$$

$$I = \frac{bh^3}{36}$$

$$\bar{y} = \frac{h}{3}$$

$$Z = \frac{bh^2}{24}$$

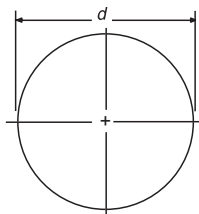
Circle

$$A = \frac{\pi d^2}{4}$$

$$J = \frac{\pi d^4}{32}$$

$$I = \frac{\pi d^4}{64}$$

$$k = \frac{d}{4}$$

$$Z = \frac{\pi d^3}{32}$$

$$\bar{y} = \frac{d}{2}$$

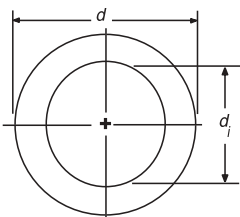
Hollow Circle

$$A = \frac{\pi d}{4}(d^2 - d_i^2)$$

$$J = \frac{\pi d}{32}(d^4 - d_i^4)$$

$$I = \frac{\pi d}{64}(d^4 - d_i^4)$$

$$k = \frac{\sqrt{d^2 + d_i^2}}{16}$$

$$Z = \frac{\pi d}{32d}(d^4 - d_i^4)$$

$$\bar{y} = \frac{d}{2}$$

ENGINEERING/TECHNICAL



Table 33: Coefficients of Friction "f"

Material	Static		Sliding	
	Dry	Lubricated	Dry	Lubricated
Aluminum on aluminum	1.35
Canvas belt on rubber lagging	0.30
Canvas belt, stitched, on steel	0.20	0.10
Canvas belt, woven, on steel	0.22	0.10
Cast iron on asbestos, fabric brake material	0.35-0.40
Cast iron on brass	0.30
Cast iron on bronze	0.22	0.07-0.08
Cast iron on cast iron	1.10	0.15	0.06-0.10
Cast iron on copper	1.05	0.29
Cast iron on lead	0.43
Cast iron on leather	0.60	0.13-0.36
Cast iron on oak (parallel)	0.30-0.50	0.07-0.20
Cast iron on magnesium	0.25
Cast iron on steel, mild	0.18	0.23	1/000 3:11
Cast iron on tin	0.32
Cast iron on zinc	0.85	0.21
Earth on earth	0.25-1.0
Glass on glass	0.94	0.40
Hemp rope on wood	0.50-0.80	0.40-0.70
Nickel on nickel	1.10	0.53	0.12
Oak on leather (parallel)	0.50-0.60	0.30-0.50
Oak on oak (parallel)	0.62	0.48	0.16
Oak on oak (perpendicular)	0.54	0.32	0.07
Rubber tire on pavement	0.8-0.9	0.6-0.7*	0.75-0.85	0.5-0.7*
Steel on ice	0.03	0.01
Steel, hard, on babbit	0.42-0.70	0.08-0.25	0.33-0.35	0.05-0.16
Steel, hard, on steel, hard	0.78	0.11-0.23	0.42	0.03-0.12
Steel, mild, on aluminum	0.61	0.47
Steel, mild, on brass	0.51	0.44
Steel, mild, on bronze	0.34	0.17
Steel, mild, on copper	0.53	0.36	0.18
Steel, mild, on steel, mild	0.74	0.57	0.09-0.19
Stone masonry on concrete	0.76
Stone masonry on ground	0.65
Wrought iron on bronze	0.19	0.07-0.08	0.18
Wrought iron on wrought iron	0.11	0.44	0.08-0.10

* Wet pavement

Table 34: U.S. Standard Sheet Metal Gages

Gage No.	Thickness in Decimal Parts of an Inch	Gage No.	Thickness in Decimal Parts of an Inch
1	.2813	20	.0359
2	.2656	21	.0329
3	.2391	22	.0299
4	.2242	23	.0269
5	.2092	24	.0239
6	.1943	25	.0209
7	.1793	26	.0179
8	.1644	27	.0164
9	.1495	28	.0149
10	.1345	29	.0135
11	.1196	30	.0120
12	.1046	31	.0109
13	.0897	32	.0102
14	.0747	33	.0094
15	.0673	34	.0086
16	.0598	35	.0078
17	.0538	36	.0070
18	.0478	37	.0066
19	.0418	38	.0063

Hardness Comparison Chart

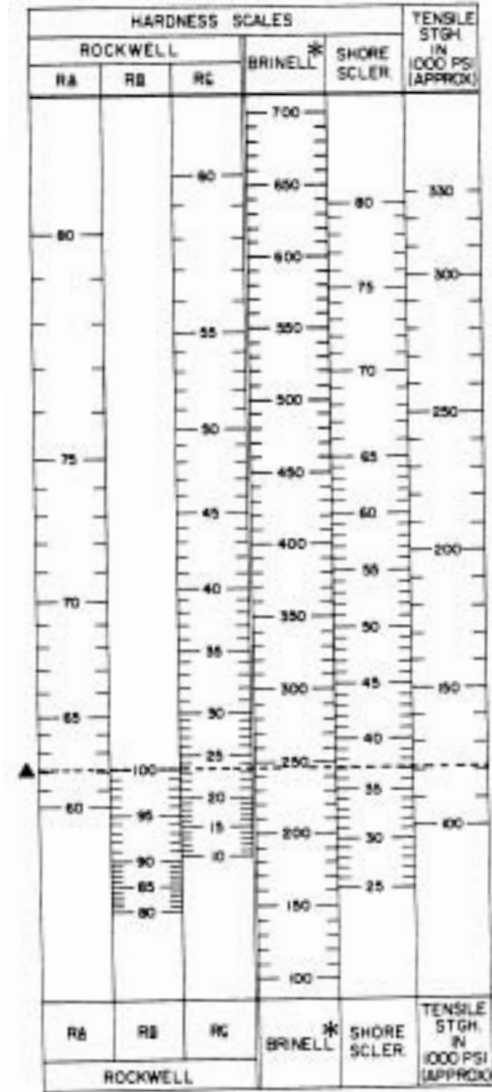

* Shaded area indicates values may vary depending on type of ball used

▲ Example: A Brinell number of 245 is equal to 62 Rockwell "A", 100 Rockwell "B", 23 Rockwell "C", 37 Shore with a tensile of approximately 120,000 PSI.

Trigonometric Formula

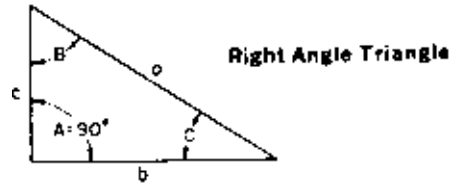
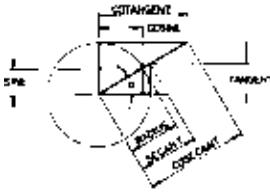

Table 35: Formulas for Finding Functions of Angles

Side opposite Hypotenuse	=	SINE
Side adjacent Hypotenuse	=	COSINE
Side opposite Side adjacent	=	TANGENT
Side adjacent Side opposite	=	COTANGENT
Hypotenuse Side adjacent	=	SECANT
Hypotenuse Side opposite	=	COSECANT

Table 36: Formulas for Finding Sides of Right Angle Triangles with an Angle and Side Known

To find: Length of side opposite	}	Hypotenuse x Sine
		Hypotenuse ÷ Coscant
		Side adjacent ÷ Cotangent
To find: Length of side adjacent	}	Hypotenuse X Cosine
		Hypotenuse ÷ Secant
		Side opposite X Cotangent
To find: Length of Hypotenuse	}	Side opposite X Cosecant
		Side opposite ÷ Sine
		Side adjacent X Secant
		Side adjacent ÷ Cosine

Table 37: To Find Angles and Sides of Right Angle Triangles

To Find Angles			To Find Angles		
To Find:	Formulas	To Find:	Formulas	To Find:	Formulas
C	$\frac{c}{a}$	=	Sine C	a	$\sqrt{b^2 + c^2}$
C	$\frac{b}{a}$	=	Cosine C	a	$c \times \text{Cosec. C}$
C	$\frac{c}{b}$	=	Tan. C	a	$c \times \text{Secant B}$
C	$\frac{b}{c}$	=	Cotan C	a	$b \times \text{Cosec. B}$
C	$\frac{a}{b}$	=	Secant C	a	$b \times \text{Secant C}$
C	$\frac{a}{c}$	=	Cosec. C	b	$\sqrt{a^2 - c^2}$
B	$\frac{c}{a}$	=	Sine B	b	$a \times \text{Sine B}$
B	$\frac{c}{a}$	=	Cosine B	b	$a \times \text{Cos. C}$
B	$\frac{b}{c}$	=	Tan. B	b	$c \times \text{Tan. B}$
B	$\frac{c}{d}$	=	Cotan. B	b	$c \times \text{Cot. C}$
B	$\frac{a}{c}$	=	Secant B	c	$\sqrt{a^2 - b^2}$
B	$\frac{a}{b}$	=	Cosec. B	c	$a \times \text{Cos. B}$
				c	$a \times \text{Sine C}$
				c	$b \times \text{Cot. B}$
				c	$b \times \text{Tan. C}$

Table 38: To Find Angles and Sides of Oblique Angle Triangle

Oblique Angle Triangle

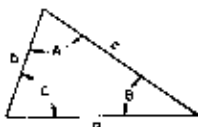

To find:	Known	Formulas	To Find:	Known	Formulas
C	A, B	$180^\circ - (A + B)$	A	B, C	$180^\circ - (B + C)$
b	a, B, A	$\frac{a \times \text{Sin. B}}{\text{Sin. A}}$	Cos. A	a, b, c	$\frac{b^2 + c^2 - a^2}{2bc}$
c	a, A, C	$\frac{a \times \text{Sin. C}}{\text{Sin. A}}$	Sin. C	c, A, a	$\frac{c \times \text{Sin. A}}{a}$
Tan. A	a, C, b	$\frac{a \times \text{Sin. C}}{b - (a \times \text{Cos. C})}$	Cot. B	a, C, b	$\frac{a \times \text{Cosec. C}}{b}$
B	A, C	$180^\circ - (A + C)$	c	b, C, B	$b \times \text{Sin. C} \times \text{Cosec. B}$
Sin. B	b, A, a	$\frac{b \times \text{Sin. A}}{a}$	---	---	-----

ENGINEERING/TECHNICAL



NEMA QUICK REFERENCE CHART

- Dimensions are for reference only
- Drawings represent standard TEFC general purpose motors

Contact your local Rockwell Automation office or go to the Motor Information Cent at 222.reliance.com for "C" dimensions

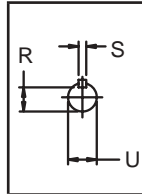

FRAME		NEMA SHAFT		KEYSEAT DIMENSIONS			FRAME		NEMA SHAFT		KEYSEAT DIMENSIONS		
		U	R	S				U	R	S			
48	48	1/2	29/64	FLAT	284T	286T	1-7/8	1-19/32	1/2				
56	56	5/8	33/64	3/16	324T	326T	2-1/8	1-27/32	1/2				
143T	145T	7/8	49/64	3/16	364T	365T	2-3/8	2-1/64	5/8				
182T	184T	1-1/8	63/64	1/4	404T	405T	2-7/8	2-29/64	3/4				
213T	215T	1-3/8	1-13/64	5/16	444T	445T	3-3/8	2-7/8	7/8				
254T	256T	1-5/8	1-13/32	3/8	447T	449T	3-3/8	2-7/8	7/8				

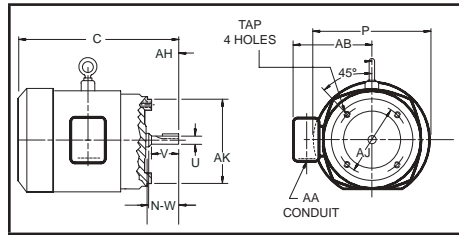
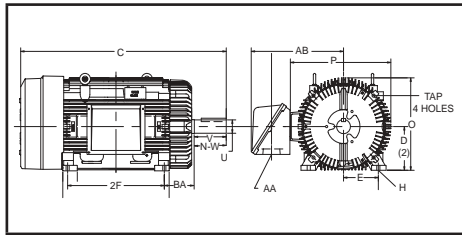

NEMA C-FACE	BA Dimensions
143TC - 145TC	2-3/4
182TC - 184 TC	3-1/2
213TC - 215TC	4-1/4
254TC-256TC	4-3/4

NEMA Frame	D	E	2F	H	N-W	O	P	U	Keyway	V	AA	AB	AH	AJ	AK	BA	Tap Size
48	3	2-1/8	2-3/4	11/32 SLOT	1-1/2	5-13/16	5-5/8	1/2		1-1/2	1/2	-	1-11/16	3-3/4	3	2-1/2	1/4-20
56	3-1/2	2-7/16	3	11/32	1-7/8	8-9/16	7-9/32	5/8	3/16x3/32	1-7/8	1/2	-	2-1/16	5-7/8	4-1/4	2-3/4	3/8-16
56H	3-1/2	2-7/16	5	SLOT	1-7/8	8-9/16	7-9/32	5/8	3/16x3/32	1-7/8	1/2	-	2-1/16	5-7/8	4-1/2	2-3/4	3/8-16
143T	3-1/2	2-7/16	4	11/32	2-1/4	8-9/16	7-9/32	7/8	3/16x3/32	2-1/4	3/4	-	2-1/8	5-7/8	4-1/2	2-1/4	3/8-16
145T	3-1/2	2-3/4	5	11/32	2-1/4	8-9/16	7-9/32	7/8	3/16x3/32	2-1/4	3/4	-	2-1/8	5-7/8	4-1/2	2-1/4	3/8-16
182	4-1/2	3-3/4	4-1/2	13/32	2-1/4	9-7/8	9-1/4	7/8	3/16x3/32	2-1/4	3/4	8-7/16	2-1/8	5-7/8	4-1/2	2-3/4	3/8-16
184	4-1/2	3-3/4	5-1/2	13/32	2-1/4	9-7/8	9-1/4	7/8	3/16x3/32	2-1/4	3/4	8-7/16	2-1/8	5-7/8	4-1/2	2-3/4	3/8-16
182T	4-1/2	3-3/4	4-1/2	13/32	2-3/4	9-7/8	9-1/4	1-1/8	1/4x1/8	2-3/4	3/4	7-13/16	2-5/8	7-1/4	8-1/2	2-3/4	1/2-13
184T	4-1/2	3-3/4	5-1/2	13/32	2-3/4	9-7/8	9-1/4	1-1/8	1/4x1/8	2-3/4	3/4	7-13/16	2-5/8	7-1/4	8-1/2	2-3/4	1/2-13
213	5-1/4	4-1/4	5-1/2	13/32	3	11-1/4	10-1/2	1-1/8	1/4x1/8	3	1	9-5/16	2-3/4	7-1/4	8-1/2	3-1/2	1/2-13
215	5-1/4	4-1/4	7	13/32	3	11-1/4	10-1/2	1-1/8	1/4x1/8	3	1	9-5/16	2-3/4	7-1/4	8-1/2	3-1/2	1/2-13
213T	5-1/4	4-1/4	5-1/2	13/32	3-3/8	11-1/4	10-1/2	1-3/8	5/16x5/32	3-3/8	1	8-11/16	3-1/8	7-1/4	8-1/2	3-1/2	1/2-13
215T	5-1/4	4-1/4	7	13/32	3-3/8	11-1/4	10-1/2	1-3/8	5/16x5/32	3-3/8	1	8-11/16	3-1/8	7-1/4	8-1/2	3-1/2	1/2-13
254U	6-1/4	5	8-1/4	17/32	3-3/4	13-1/4	13-1/4	1-3/8	5/16x5/32	3-3/4	1-1/4	10-13/16	3-1/2	7-1/4	8-1/2	4-1/4	1/2-13
256U	6-1/4	5	10	17/32	3-3/4	13-1/4	13-1/4	1-3/8	5/16x5/32	3-3/4	1-1/4	10-13/16	3-1/2	7-1/4	8-1/2	4-1/4	1/2-13
254T	6-1/4	5	8-1/4	17/32	4	13-1/4	13-1/4	1-5/8	3/8x3/16	4	1-1/4	10-3/4	3-3/4	7-1/4	8-1/2	4-1/4	1/2-13
256T	6-1/4	5	10	17/32	4	13-1/4	13-1/4	1-5/8	3/8x3/16	4	1-1/4	10-3/4	3-3/4	7-1/4	8-1/2	4-1/4	1/2-13
284U	7	5-1/2	9-1/2	17/32	4-7/8	14-3/4	14-7/8	1-5/8	3/8x3/16	4-7/8	1-1/2	12-5/8	4-5/8	9	10-1/2	4-3/4	1/2-13
286U	7	5-1/2	11	17/32	4-7/8	14-3/4	14-7/8	1-5/8	3/8x3/16	4-7/8	1-1/2	12-5/8	4-5/8	9	10-1/2	4-3/4	1/2-13
284T	7	5-1/2	9-1/2	17/32	4-5/8	14-3/4	14-7/8	1-7/8	1/2x1/4	4-5/8	1-1/2	12-3/4	4-3/8	9	10-1/2	4-3/4	1/2-13
286T	7	5-1/2	11	17/32	4-5/8	14-3/4	14-7/8	1-7/8	1/2x1/4	4-5/8	1-1/2	12-3/4	4-3/8	9	10-1/2	4-3/4	1/2-13
284TS	7	5-1/2	9-1/2	17/32	3-1/4	14-3/4	14-7/8	1-5/8	3/8x3/16	3-1/4	1-1/2	12-3/4	3	9	10-1/2	4-3/4	1/2-13
286TS	7	5-1/2	11	17/32	3-1/4	14-3/4	14-7/8	1-5/8	3/8x3/16	3-1/4	1-1/2	12-3/4	3	9	10-1/2	4-3/4	1/2-13
324U	8	6-1/4	10-1/2	21/32	5-5/8	16-11/16	17	1-7/8	1/2x1/4	5-5/8	2	15-7/16	5-3/8	11	12-1/2	5-1/4	5/8-11
326U	8	6-1/4	12	21/32	5-5/8	16-11/16	17	1-7/8	1/2x1/4	5-5/8	2	15-7/16	5-3/8	11	12-1/2	5-1/4	5/8-11
324T	8	6-1/4	10-1/2	21/32	5-1/4	16-11/16	17	2-1/8	1/2x1/4	5-1/4	2	15-3/16	5	11	12-1/2	5-1/4	5/8-11
326T	8	6-1/4	12	21/32	5-1/4	16-11/16	17	2-1/8	1/2x1/4	5-1/4	2	15-3/16	5	11	12-1/2	5-1/4	5/8-11
324TS	8	6-1/4	10-1/2	21/32	3-3/4	16-11/16	17	1-7/8	1/2x1/4	3-3/4	2	15-3/16	3-1/2	11	12-1/2	5-1/4	5/8-11
326TS	8	6-1/4	12	21/32	3-3/4	16-11/16	17	1-7/8	1/2x1/4	3-3/4	2	15-3/16	3-1/2	11	12-1/2	5-1/4	5/8-11
364U	9	7	11-1/4	21/32	6-3/8	18-1/2	19-1/2	2-1/8	1/2x1/4	6-3/8	2-1/2	18	6-1/8	11	12-1/2	5-7/8	5/8-11
365U	9	7	12-1/4	21/32	6-3/8	18-1/2	19-1/2	2-1/8	1/2x1/4	6-3/8	2-1/2	18	6-1/8	11	12-1/2	5-7/8	5/8-11
364T	9	7	11-1/4	21/32	5-7/8	18-1/2	19-1/2	2-3/8	5/8x5/16	5-7/8	2-1/2	18-1/16	5-5/8	11	12-1/2	5-7/8	5/8-11
365T	9	7	12-1/4	21/32	5-7/8	18-1/2	19-1/2	2-3/8	5/8x5/16	5-7/8	2-1/2	18-1/16	5-5/8	11	12-1/2	5-7/8	5/8-11
364TS	9	7	11-1/4	21/32	3-3/4	18-1/2	19-1/2	1-7/8	1/2x1/4	3-3/4	2-1/2	18-1/16	3-1/2	11	12-1/2	5-7/8	5/8-11
365TS	9	7	12-1/4	21/32	3-3/4	18-1/2	19-1/2	1-7/8	1/2x1/4	3-3/4	2-1/2	18-1/16	3-1/2	11	12-1/2	5-7/8	5/8-11
404U	10	8	12-1/4	13/16	7-1/8	21-5/16	22-1/2	2-3/8	5/8x5/16	7-1/8	3	19-1/4	6-7/8	11	12-1/2	6-5/8	5/8-11
405U	10	8	13-3/4	13/16	7-1/8	21-5/16	22-1/2	2-3/8	5/8x5/16	7-1/8	3	19-1/4	6-7/8	11	12-1/2	6-5/8	5/8-11
404T	10	8	12-1/4	13/16	7-1/4	21-5/16	22-1/2	2-7/8	3/4x3/8	7-1/4	3	19-5/16	7	11	12-1/2	6-5/8	5/8-11
405T	10	8	13-3/4	13/16	7-1/4	21-5/16	22-1/2	2-7/8	3/4x3/8	7-1/4	3	19-5/16	7	11	12-1/2	6-5/8	5/8-11
404TS	10	8	12-1/4	13/16	4-1/4	21-5/16	22-1/2	2-1/8	1/2x1/4	4-1/4	3	19-5/16	4	11	12-1/2	6-5/8	5/8-11
405TS	10	8	13-3/4	13/16	4-1/4	21-5/16	22-1/2	2-1/8	1/2x1/4	4-1/4	3	19-5/16	4	11	12-1/2	6-5/8	5/8-11
444U	11	9	14-1/2	13/16	8-5/8	23-3/8	25-1/4	2-7/8	3/4x3/8	8-5/8	3	22-3/16	8-3/8	14	16	7-1/2	5/8-11
445U	11	9	16-1/2	13/16	8-5/8	23-3/8	25-1/4	2-7/8	3/4x3/8	8-5/8	3	22-3/16	8-3/8	14	16	7-1/2	5/8-11
444T	11	9	14-1/2	13/16	8-1/2	23-3/8	25-1/4	3-3/8	7/8x7/16	8-1/2	3	23-3/8	8-1/4	14	16	7-1/2	5/8-11
445T	11	9	16-1/2	13/16	8-1/2	23-3/8	25-1/4	3-3/8	7/8x7/16	8-1/2	3	23-3/8	8-1/4	14	16	7-1/2	5/8-11
447T	11	9	20	13/16	8-1/2	23-5/8	26	3-3/8	7/8x7/16	8-1/2	3	23-7/8	8-1/4	14	16	7-1/2	5/8-11
449T	11	9	25	13/16	8-1/2	23-5/8	26	3-3/8	7/8x7/16	8-1/2	3	23-7/8	8-1/4	14	16	7-1/2	5/8-11
444TS	11	9	14-1/2	13/16	4-3/4	23-3/8	25-1/4	2-3/8	5/8x5/16	4-3/4	3	23-3/8	4-1/2	14	16	7-1/2	5/8-11
445TS	11	9	16-1/2	13/16	4-3/4	23-3/8	25-1/4	2-3/8	5/8x5/16	4-3/4	3	23-3/8	4-1/2	14	16	7-1/2	5/8-11
447TS	11	9	20	13/16	4-3/4	23-5/8	26	2-3/8	5/8x5/16	4-3/4	4 NPT	23-7/8	4-1/2	14	16	7-1/2	5/8-11
449TS	11	9	25	13/16	4-3/4	23-5/8	26	2-3/8	5/8x5/16	4-3/4	4 NPT	23-7/8	4-1/2	14	16	7-1/2	5/8-11

IEC QUICK REFERENCE CHART

- Dimensins are for reference only
 - Drawings represent standard TEFC general purpose motors
- Contact your local Rockwell Automation office or go to the Motor Information Cent at 222.reliance.com for "L" dimensions

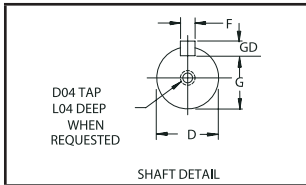
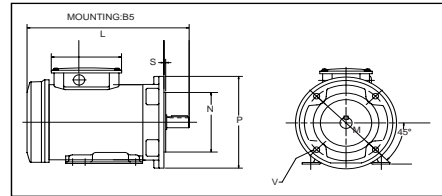
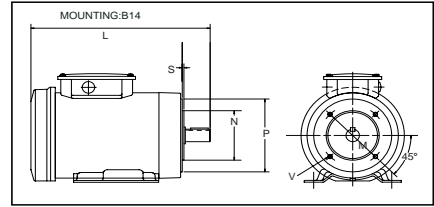
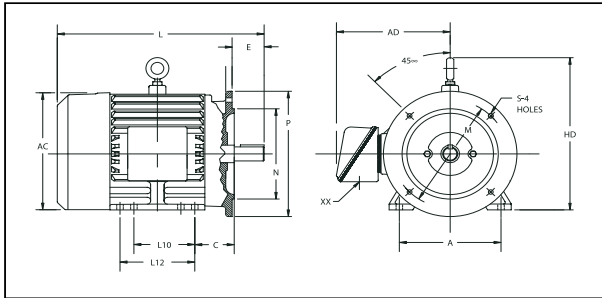

KEY AND KEYSEAT DIMENSIONS									
FRAME	D	G	F	GD	FRAME	D	G	F	GD
71	14	11	5	5	160	37	42	12	8
80	19	15.5	6	6	180	48	42.5	14	9
90	24	20	8	7	200	55	49	16	10
100	28	24	8	7	225	60	53	18	11
112	28	24	8	7	250	70	67.5	20	12
132	38	33	10	8	280	80	71	22	14

Frame	B3 RIGID BASE				SHAFT		B5 FLANGE				B14 FACE				GENERAL					
	A	L10	L12	HD	C	E	D	N	M	P	S	V	N	M	P	S	V	AC	AD	XX
71	-	-	-	-	-	-	-	110	130	160	"3,5"	"9,5"	70	85	105	2.5	M6	143	-	13
80	125	100	-	188	50	40	19	130	165	200	"3,5"	"11,5"	80	100	120	3	M6	143	-	13
90	140	100	125	208	56	50	24	130	165	200	"3,5"	"11,5"	95	115	140	3	M8	163	-	13
100	160	112	140	229	63	60	28	180	215	250	4	14	110	130	160	3.5	M8	175	-	19
112S	190	114	-	301.8	71.4	60	28	180	215	250	4	14	110	130	160	3.5	M8	243	210	32
112M	190	-	140	301.8	71.4	60	28	180	215	250	4	14	110	130	160	3.5	M8	243	210	32
132S	216	140	-	336.6	88.9	80	38	230	265	300	4	14	130	165	200	3.5	M8	286	243	32
132M	216	-	178	336.6	88.9	80	38	230	265	300	4	14	130	165	200	3.5	M8	286	243	32
160M	254	210	-	399	108	110	42	250	300	350	5	18	180	215	250	4	M12	324	320	40
160L	254	-	254	399	108	110	42	250	300	350	5	18	180	215	250	4	M12	324	320	40
180M	279	241	-	436	121	110	48	250	300	350	5	18	398	355	40			398	355	40
180L	279	-	279	436	121	110	48	250	300	350	5	18	398	355	40			398	355	40
200M	318	267	-	486	133	110	55	300	350	400	5	18	442	445	50			442	445	50
200L	318	-	305	486	133	110	55	300	350	400	5	18	442	445	50			442	445	50
225S	356	286	-	545	149	140	60	350	400	450	5	18	490	470	50			490	470	50
225M	356	-	311	545	149	140	60	350	400	450	5	18	490	470	50			490	470	50
250S	406	311	-	616	168	140	65											600	510	63
250M	406	-	349	616	168	140	65											600	535	63
280S	457	368	-	677	190	140	75											650	535	63
280M	457	-	419	677	190	140	75											650	535	63
280K	457	500	-	677	190	140	75											650	535	63
280H	457	630	-	677	190	140	75											650	535	63
L280H	457	635	-	677	202	205	75											650	535	63

NOTES



ONE SYSTEM • ONE SOURCE • ONE SOLUTION

Performance & Convenience from System-1

Rockwell Automation offers a unique service aimed at providing customized solutions for customers. This service, known as System-1, combines the functions of inside sales, marketing and engineering to provide a single source for the design, selection and procurement of multiple component systems.

Once the System-1 Group receives the customer's specifications, the criteria are reviewed and the correct products for the application are selected and priced. The group then checks into deliveries and provides a written quote to the customer. Throughout the process, they work to ensure that the order is available when the customer needs it.

One point of contact within the System-1 Group covers all of the product lines we offer. Whether you need a standard package or are looking for one that is more customized, System-1 is the source for all of your product needs. System-1 also has the capability to ship the total package pre-assembled and on a single pallet. If products are to be assembled on-site, the items are boxed together for ease of identification. All orders are tagged on the outside of the pallet or box with the description number designated for the project.

A centralized source for warranty administration is also a feature of System-1. If one of the products you ordered needs warranty attention, you can call the System-1 Group directly. Our experts will assess the situation and provide a solution to satisfy your warranty needs.

Lowering Total Cost of Ownership for Industry

System-1 has a long history of providing drive and tail conveyor assemblies for the aggregate industry. These systems are designed to provide long lasting, power-matched solutions to meet bulk material conveying requirements. They incorporate high quality, long lasting DODGE and RELIANCE products, including reducers, conveyor pulleys, bearings, take-up frames and motors. A quick selection guide is available for pre-engineered assemblies and simplifies the design of the conveyor process because the selection of components is already done. For users requiring a more customized bulk conveyor solution, System-1 offers a complete package of power-matched DODGE and RELIANCE products, selected for specific applications.

The System-1 Group is also able to provide a standard solution for the food and beverage industry. System-1 offers these users a standard package that includes three products well suited for their applications: a DODGE QUANTIS Unit, a RELIANCE XE Motor and a Reliance SP600 AC Drive. The combination of these products offers users lower maintenance costs and more versatility.

In a typical food plant, converting equipment and conveyors are often powered by a mechanical drive. However, the standard package offered by System-1 presents a more reliable and efficient solution because our drive is easy to control and monitor with an external keypad. Our package also operates at more than 90% efficiency, requires less maintenance and maximizes customer uptime.

Standard packages offered for this industry can be specified for either in-line or right-angle configurations based on the applications. For users that require washdown capabilities, there is also a modified package containing products specially manufactured for these environments.

The System-1 Group brings performance and convenience to every order they receive. By providing ease of selection, procurement and delivery, the System-1 Group is able to lower your total cost of ownership, while providing the power-matched product solutions you need for all your mechanical and electrical power transmission needs.

For more information on these services, contact a System-1 Product Specialist at 864-284-5767 or access our System-1 page located at www.dodge-pt.com or www.reliance.com.

SYSTEM-1

DODGE



Bulk Conveyor

Use System-1 to quote your Bulk Conveyor Drive Systems. Packages include DODGE and Reliance products such as: Mine Duty Extra Conveyor Pulleys, TAF Bearings, TORQUE-ARM II Shaft Mounted Reducers, V-drives, Fluid Couplings and Premium Efficient Extra Tough Motors.

System-1 also offers pre-packaged drive and tail conveyor assemblies. These packages were designed for Bulk Conveyor applications offering a variety of common configurations. The drive system utilizes a Reliance Motor driving a TORQUE-ARM II Shaft Mount Reducer through a v-belt drive. System-1 will ship the motor, reducer and v-drive assembled with the belt guard and motor mount. The pulley, shaft and bearings will be delivered as a single piece, ready to be mounted to the reducer. Contact a System-1 representative to receive the most efficient power transmission solution available.



Custom Fabricated Baseplates

System-1 can provide custom fabricated base plates for mounting various DODGE Gear Reducers and

Reliance Motors, including made to order coupling and v-belt drive guards.



Variable Speed Drives

Packages include DODGE QUANTIS Gear Reducers with Reliance Premium Efficient Motors and Reliance Variable Frequency Drives for variable speed applications. These packages provide compact, low maintenance solutions that are easy to install.



Creep Drive

A Reliance Motor drives a DODGE MAXUM Reducer through a fluid coupling for a soft start to maximize the life of the system. When the driven equipment needs to be inspected, an over-running clutch disengages the main drive and engages a smaller Reliance/DODGE drive system connected to the main drive input shaft. The equipment now runs at a fraction of the normal operating speed. This complete package is delivered pre-assembled on a heavy duty baseplate for ease of installation.

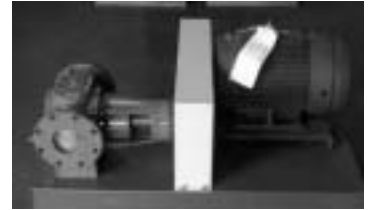

Pump Assemblies

Customer supplied pumps can be coupled via DODGE Coupling or V-belt drive to Reliance Motor with a slide base for belt tensioning. All components are assembled on a custom made baseplate fabricated to meet the customer's specifications. A custom made safety yellow guard is designed specifically for the application. This solution allows for easy integration into the customer's existing application.



Offset Parallel

System-1 provides offset parallel drive packages for applications requiring high horsepower which can include the incorporation of external backstops.

Why Should You Use System-1?

- Saves you time
- Project coordination
- Optimized product selection
- Products / services bundling
- Pre-assembled Packages
- Freight administration
- Single source warranty
- Reduces the Total Cost of Ownership

CUSTOMIZED CONVEYOR PACKAGE SOLUTIONS

Use this quick fax form to receive your customized solution quotation

TO: SYSTEM-1 GROUP

FAX: (864) 281-2355

RE: CUSTOMIZED QUOTATION

FROM: _____
 COMPANY / CUSTOMER NUM: _____
 CITY, STATE: _____
 PHONE: _____
 FAX: _____

Desired System Capacity (TPH) _____
 Material Type _____
 Estimated Weight of Material _____
 Desired Belt Width _____
 Desired Belt Speed _____

Length of Conveyor _____
 Change in Elevation _____
 Number of Belt Scrapers/Plows _____
 Idler Angle _____
 Bearing Center Distance _____

Desired Conveyor Profile (Please Circle Your Selection)

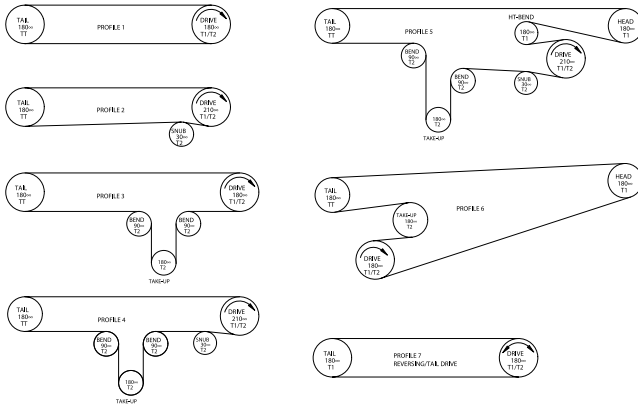

Additional Comments

Motor Type:

- CALIBRE (Cast Iron)
- E-Master
- Aggregate Industry

- Extra-Tough
- Torque Max (High Torque)

Reducer Type:

- QUANTIS
- TORQUE-ARM (TXT)
- TORQUE-ARM II (TAIL)

- MAXUM
- CYCLONE

Bearing Type:

- SCM Ball Bearing
- Type-E
- S-2000
- IMPERIAL

- TAF
- IMPERIAL SAF
- USAF
- SPLIT-SPHERE

Conveyor Pulley Type:

- Cema Drum
- Mine Duty Drum
- Mine Duty Extra Drum
- 1/2" Herringbone Lagging
- 1/2" Plain Lagging
- 1/2" Diamond Lagging
- 1/2" Holz Lagging

- Cema Wing
- Mine Duty Extra Wing
- Wing Lagging

SYSTEM-1



CUSTOMIZED CONVEYOR PACKAGE SOLUTIONS

Use this quick fax form to receive your customized solution quotation

TO: SYSTEM-1 GROUP
 FAX: (864) 281-2355
 RE: CUSTOMIZED QUOTATION

FROM: _____
 COMPANY / CUST NUM: _____
 CITY, STATE: _____
 PHONE: _____
 FAX: _____

Motor HP / Voltage: _____
 Reducer Output Speed: _____
 Reducer Configuration: _____

- Right Angle
- In-Line
- Offset Parallel
- Worm Gear

- Output Connection:
- Chain Drive
 - Synchronous Drive
 - Coupled

Mounting:

- Shaft
- Baseplate
- Flange

Softstart Device:

- Yes
- No

Motor/Reducer Connection:

- Direct Coupled
- Belt Driven
- C-face

Environment:

- Standard
- Extra Tough
- Washdown
- Division I

Output Torque Requirements: _____
 Is High Starting Torque Required?

- Yes
- No

Classes _____
 Groups _____
 Temp Code _____

Variable Speed

(Circle One) Constant or Variable Torque

Speed Range _____

- No

Division II

Classes _____
 Groups _____
 Temp Code _____

Application Description / Other Comments:

PART NUMBER INDEX



Part No.	Page	Part No.	Page	Part No.	Page	Part No.	Page	Part No.	Page	Part No.	Page
014148	G1-28	056C150B038L1A		056C150B240K1A		056C150T030S1A		056C200B030LKA		056C200B200L1A	
	G2-66, G2-67,		G5-15		G5-16		G5-15		G5-17		G5-18
	G2-68, G2-69,	056C150B038LKA		056C150B240L1A		056C150T038S1A		056C200B038K1A		056C200B200LKA	
	G2-80, G3-27,		G5-15		G5-16		G5-15		G5-17		G5-18
	G3-28, G3-29,	056C150B040K1A		056C150B240LKA		056C150T040S1A		056C200B038L1A		056C200B240K1A	
	G3-30, G3-31,		G5-15		G5-16		G5-15		G5-17		G5-18
	G3-32, G3-33,	056C150B040L1A		056C150B300K1A		056C150T050S1A		056C200B038LKA		056C200B240L1A	
	G3-40		G5-15		G5-16		G5-15		G5-17		G5-18
014524	G3-45	056C150B040LKA		056C150B300L1A		056C150T060S1A		056C200B040K1A		056C200B240LKA	
014525	G3-45		G5-15		G5-16		G5-16		G5-17		G5-18
014526	G3-45	056C150B050K1A		056C150B300LKA		056C150T075S1A		056C200B040L1A		056C200B300K1A	
014527	G3-45		G5-15		G5-16		G5-16		G5-17		G5-18
014528	G3-45	056C150B050L1A		056C150S007S1A		056C150T080S1A		056C200B040LKA		056C200B300L1A	
021832	G2-160		G5-15		G5-15		G5-16		G5-17		G5-18
050250	G5-49	056C150B050LKA		056C150S009S1A		056C150T090S1A		056C200B050K1A		056C200B300LKA	
050253	G5-49,		G5-15		G5-15		G5-16		G5-17		G5-18
	G5-50	056C150B060K1A		056C150S010S1A		056C150T100S1A		056C200B050L1A		056C200S009S1A	
050994	G5-50		G5-16		G5-15		G5-16		G5-17		G5-17
051929	G5-49	056C150B060L1A		056C150S015S1A		056C150T125S1A		056C200B050LKA		056C200S010S1A	
053202	G5-49		G5-16		G5-15		G5-16		G5-17		G5-17
055089	G5-50	056C150B060LKA		056C150S018S1A		056C150T150S1A		056C200B060K1A		056C200S015S1A	
056C150B007K1A	G5-15		G5-16		G5-15		G5-16		G5-17		G5-17
056C150B007L1A	G5-15	056C150B075K1A		056C150S020S1A		056C150T160S1A		056C200B060L1A		056C200S018S1A	
056C150B007LKA	G5-15		G5-16		G5-15		G5-16		G5-17		G5-17
056C150B009K1A	G5-15	056C150B075L1A		056C150S025S1A		056C150T200S1A		056C200B060LKA		056C200S020S1A	
056C150B009L1A	G5-15		G5-16		G5-15		G5-16		G5-17		G5-17
056C150B009LKA	G5-15	056C150B075LKA		056C150S030S1A		056C150T240S1A		056C200B075K1A		056C200S025S1A	
056C150B010K1A	G5-15		G5-16		G5-15		G5-16		G5-18		G5-17
056C150B010L1A	G5-15	056C150B080K1A		056C150S038S1A		056C150T300S1A		056C200B075L1A		056C200S030S1A	
056C150B010LKA	G5-15		G5-16		G5-15		G5-16		G5-18		G5-17
056C150B011K1A	G5-15	056C150B080L1A		056C150S040S1A		056C200B009K1A		056C200B075LKA		056C200S038S1A	
056C150B011L1A	G5-15		G5-16		G5-15		G5-17		G5-18		G5-17
056C150B011LKA	G5-15	056C150B080LKA		056C150S050S1A		056C200B009L1A		056C200B080K1A		056C200S040S1A	
056C150B012K1A	G5-15		G5-16		G5-15		G5-17		G5-18		G5-17
056C150B012L1A	G5-15	056C150B090K1A		056C150S060S1A		056C200B009LKA		056C200B080L1A		056C200S050S1A	
056C150B012LKA	G5-15		G5-16		G5-16		G5-17		G5-18		G5-17
056C150B013K1A	G5-15	056C150B090L1A		056C150S075S1A		056C200B010K1A		056C200B080LKA		056C200S060S1A	
056C150B013L1A	G5-15		G5-16		G5-16		G5-17		G5-18		G5-17
056C150B013LKA	G5-15	056C150B090LKA		056C150S080S1A		056C200B010L1A		056C200B090K1A		056C200S075S1A	
056C150B014K1A	G5-15		G5-16		G5-16		G5-17		G5-18		G5-18
056C150B014L1A	G5-15	056C150B100K1A		056C150S090S1A		056C200B010LKA		056C200B090L1A		056C200S080S1A	
056C150B014LKA	G5-15		G5-16		G5-16		G5-17		G5-18		G5-18
056C150B015K1A	G5-15	056C150B100L1A		056C150S100S1A		056C200B015K1A		056C200B090LKA		056C200S090S1A	
056C150B015L1A	G5-15		G5-16		G5-16		G5-17		G5-18		G5-18
056C150B015LKA	G5-15	056C150B100LKA		056C150S125S1A		056C200B015L1A		056C200B100K1A		056C200S100S1A	
056C150B016K1A	G5-15		G5-16		G5-16		G5-17		G5-18		G5-18
056C150B016L1A	G5-15	056C150B125K1A		056C150S150S1A		056C200B015LKA		056C200B100L1A		056C200S125S1A	
056C150B016LKA	G5-15		G5-16		G5-16		G5-17		G5-18		G5-18
056C150B017K1A	G5-15	056C150B125L1A		056C150S160S1A		056C200B018K1A		056C200B100LKA		056C200S150S1A	
056C150B017L1A	G5-15		G5-16		G5-16		G5-17		G5-18		G5-18
056C150B017LKA	G5-15	056C150B125LKA		056C150S200S1A		056C200B018L1A		056C200B125K1A		056C200S160S1A	
056C150B018K1A	G5-15		G5-16		G5-16		G5-17		G5-18		G5-18
056C150B018L1A	G5-15	056C150B150K1A		056C150S240S1A		056C200B018LKA		056C200B125L1A		056C200S200S1A	
056C150B018LKA	G5-15		G5-16		G5-16		G5-17		G5-18		G5-18
056C150B019K1A	G5-15	056C150B150L1A		056C150S300S1A		056C200B020K1A		056C200B150L1A		056C200S240S1A	
056C150B019L1A	G5-15		G5-16		G5-16		G5-17		G5-18		G5-18
056C150B019LKA	G5-15	056C150B150LKA		056C150T007S1A		056C200B020L1A		056C200B150K1A		056C200S300S1A	
056C150B020K1A	G5-15		G5-16		G5-15		G5-17		G5-18		G5-18
056C150B020L1A	G5-15	056C150B160K1A		056C150T009S1A		056C200B020LKA		056C200B150L1A		056C200T009S1A	
056C150B020LKA	G5-15		G5-16		G5-15		G5-17		G5-18		G5-17
056C150B021K1A	G5-15	056C150B160L1A		056C150T010S1A		056C200B025K1A		056C200B150LKA		056C200T010S1A	
056C150B021L1A	G5-15		G5-16		G5-15		G5-17		G5-18		G5-17
056C150B021LKA	G5-15	056C150B160LKA		056C150T015S1A		056C200B025L1A		056C200B160K1A		056C200T015S1A	
056C150B022K1A	G5-15		G5-16		G5-15		G5-17		G5-18		G5-17
056C150B022L1A	G5-15	056C150B200K1A		056C150T018S1A		056C200B025LKA		056C200B160L1A		056C200T018S1A	
056C150B022LKA	G5-15		G5-16		G5-15		G5-17		G5-18		G5-17
056C150B023K1A	G5-15	056C150B200L1A		056C150T020S1A		056C200B030K1A		056C200B160LKA		056C200T020S1A	
056C150B023L1A	G5-15		G5-16		G5-15		G5-17		G5-18		G5-17
056C150B023LKA	G5-15	056C150B200LKA		056C150T025S1A		056C200B030L1A		056C200B200K1A		056C200T025S1A	
056C150B024K1A	G5-15		G5-16		G5-15		G5-17		G5-18		G5-17

PART NUMBER INDEX



Part No.	Page	Part No.	Page	Part No.	Page	Part No.	Page	Part No.	Page	Part No.	Page
056C200T030S1A		056C262B025LKA		056C262B160L1A	...	056C262T010S1A	...	056C350B086K1A	...	056C350S240S1A	...
..... G5-17	 G5-19	 G5-20	 G5-19	 G5-23	 G5-23	
056C200T038S1A	...	056C262B030K1A	...	056C262B160LKA	...	056C262T015S1A	...	056C350B086L1A	...	056C350S300S1A	...
..... G5-17	 G5-19	 G5-20	 G5-19	 G5-23	 G5-23	
056C200T040S1A	...	056C262B030L1A	...	056C262B200K1A	...	056C262T018S1A	...	056C350B086LKA	...	056C350T040S1A	...
..... G5-17	 G5-19	 G5-20	 G5-19	 G5-23	 G5-22	
056C200T050S1A	...	056C262B030LKA	...	056C262B200L1A	...	056C262T020S1A	...	056C350B100K1A	...	056C350T050S1A	...
..... G5-17	 G5-19	 G5-20	 G5-19	 G5-23	 G5-22	
056C200T060S1A	...	056C262B038K1A	...	056C262B200LKA	...	056C262T025S1A	...	056C350B100L1A	...	056C350T060S1A	...
..... G5-17	 G5-19	 G5-20	 G5-19	 G5-23	 G5-23	
056C200T075S1A	...	056C262B038L1A	...	056C262B240K1A	...	056C262T030S1A	...	056C350B100LKA	...	056C350T075S1A	...
..... G5-18	 G5-19	 G5-20	 G5-19	 G5-23	 G5-23	
056C200T080S1A	...	056C262B038LKA	...	056C262B240L1A	...	056C262T038S1A	...	056C350B125K1A	...	056C350T080S1A	...
..... G5-18	 G5-19	 G5-20	 G5-19	 G5-23	 G5-23	
056C200T090S1A	...	056C262B040K1A	...	056C262B240LKA	...	056C262T040S1A	...	056C350B125L1A	...	056C350T086S1A	...
..... G5-18	 G5-19	 G5-20	 G5-19	 G5-23	 G5-23	
056C200T100S1A	...	056C262B040L1A	...	056C262B300K1A	...	056C262T050S1A	...	056C350B125LKA	...	056C350T100S1A	...
..... G5-18	 G5-19	 G5-20	 G5-19	 G5-23	 G5-23	
056C200T125S1A	...	056C262B040LKA	...	056C262B300L1A	...	056C262T060S1A	...	056C350B150K1A	...	056C350T125S1A	...
..... G5-18	 G5-19	 G5-20	 G5-20	 G5-23	 G5-23	
056C200T150S1A	...	056C262B050K1A	...	056C262B300LKA	...	056C262T075S1A	...	056C350B150L1A	...	056C350T150S1A	...
..... G5-18	 G5-19	 G5-20	 G5-20	 G5-23	 G5-23	
056C200T160S1A	...	056C262B050L1A	...	056C262S007S1A	...	056C262T080S1A	...	056C350B150LKA	...	056C350T160S1A	...
..... G5-18	 G5-19	 G5-19	 G5-21	 G5-23	 G5-23	
056C200T200S1A	...	056C262B050LKA	...	056C262S009S1A	...	056C262T090S1A	...	056C350B160K1A	...	056C350T200S1A	...
..... G5-18	 G5-19	 G5-19	 G5-21	 G5-23	 G5-23	
056C200T240S1A	...	056C262B060K1A	...	056C262S010S1A	...	056C262T100S1A	...	056C350B160L1A	...	056C350T240S1A	...
..... G5-18	 G5-20	 G5-19	 G5-21	 G5-23	 G5-23	
056C200T300S1A	...	056C262B060L1A	...	056C262S015S1A	...	056C262T125S1A	...	056C350B160LKA	...	056C350T300S1A	...
..... G5-18	 G5-20	 G5-19	 G5-21	 G5-23	 G5-23	
056C262B007K1A	...	056C262B060LKA	...	056C262S018S1A	...	056C262T150S1A	...	056C350B200K1A	...	07901913AW	G5-50
..... G5-19	 G5-20	 G5-19	 G5-20	 G5-23		07901938AW	G5-50
056C262B007L1A	...	056C262B075K1A	...	056C262S020S1A	...	056C262T160S1A	...	056C350B200L1A	...	07906722AB	G5-50
..... G5-19	 G5-20	 G5-19	 G5-20	 G5-23		079067-22-AB
056C262B007LKA	...	056C262B075L1A	...	056C262S025S1A	...	056C262T200S1A	...	056C350B200LKA G4-113,G4-115	
..... G5-19	 G5-20	 G5-19	 G5-20	 G5-23		07906722AD	G5-50
056C262B009K1A	...	056C262B075LKA	...	056C262S030S1A	...	056C262T240S1A	...	056C350B240K1A	...	07914702D	G5-49
..... G5-19	 G5-20	 G5-19	 G5-20	 G5-23		07914702K	G5-49
056C262B009L1A	...	056C262B080K1A	...	056C262S038S1A	...	056C262T300S1A	...	056C350B240L1A	...	07914702X	G5-49
..... G5-19	 G5-20	 G5-19	 G5-20	 G5-23		07914703AA	G5-49
056C262B009LKA	...	056C262B080L1A	...	056C262S040S1A	...	056C350B040K1A	...	056C350B240LKA	...	07914703AB	G5-46,
..... G5-19	 G5-20	 G5-19	 G5-22	 G5-23	 G5-48,G5-50	
056C262B010K1A	...	056C262B080LKA	...	056C262S050S1A	...	056C350B040L1A	...	056C350B300K1A	...	07914703DD	G5-46,
..... G5-19	 G5-20	 G5-19	 G5-22	 G5-23	 G5-48,G5-50	
056C262B010L1A	...	056C262B090K1A	...	056C262S060S1A	...	056C350B040LKA	...	056C350B300L1A	...	07914703E	G5-49
..... G5-19	 G5-20	 G5-20	 G5-22	 G5-23		07914703F	G5-46,
056C262B010LKA	...	056C262B090L1A	...	056C262S075S1A	...	056C350B050K1A	...	056C350B300LKA G5-48,G5-50	
..... G5-19	 G5-20	 G5-20	 G5-22	 G5-23		07914703G	G5-49
056C262B015K1A	...	056C262B090LKA	...	056C262S080S1A	...	056C350B050L1A	...	056C350S040S1A	...	07914703N	G5-49
..... G5-19	 G5-20	 G5-21	 G5-22	 G5-22		07914703R	G5-46,
056C262B015L1A	...	056C262B100K1A	...	056C262S090S1A	...	056C350B050LKA	...	056C350S050S1A G5-48,G5-50	
..... G5-19	 G5-20	 G5-21	 G5-22	 G5-22		07915613B	G5-51
056C262B015LKA	...	056C262B100L1A	...	056C262S100S1A	...	056C350B060K1A	...	056C350S060S1A	...	07915613C	G5-51
..... G5-19	 G5-20	 G5-21	 G5-23	 G5-23		07915613D	G5-51
056C262B018K1A	...	056C262B100LKA	...	056C262S125S1A	...	056C350B060L1A	...	056C350S075S1A	...	07915613E	G5-51
..... G5-19	 G5-20	 G5-21	 G5-23	 G5-23		07915613F	G5-51
056C262B018L1A	...	056C262B125K1A	...	056C262S150S1A	...	056C350B060LKA	...	056C350S080S1A	...	07915613G	G5-51
..... G5-19	 G5-20	 G5-20	 G5-23	 G5-23		07915613H	G5-51
056C262B018LKA	...	056C262B125L1A	...	056C262S160S1A	...	056C350B075K1A	...	056C350S086S1A	...	07915613K	G5-51
..... G5-19	 G5-20	 G5-20	 G5-23	 G5-23		07915613L	G5-51
056C262B020K1A	...	056C262B125LKA	...	056C262S200S1A	...	056C350B075L1A	...	056C350S100S1A	...	07915613M	G5-51
..... G5-19	 G5-20	 G5-20	 G5-23	 G5-23		07915613N	G5-51
056C262B020L1A	...	056C262B150K1A	...	056C262S240S1A	...	056C350B075LKA	...	056C350S125S1A	...	07915613P	G5-51
..... G5-19	 G5-20	 G5-20	 G5-23	 G5-23		07915613R	G5-51
056C262B020LKA	...	056C262B150L1A	...	056C262S300S1A	...	056C350B080K1A	...	056C350S150S1A	...	07915613S	G5-51
..... G5-19	 G5-20	 G5-20	 G5-23	 G5-23		07915614C	G5-51
056C262B025K1A	...	056C262B150LKA	...	056C262T007S1A	...	056C350B080L1A	...	056C350S160S1A	...	07915614D	G5-51
..... G5-19	 G5-20	 G5-19	 G5-23	 G5-23		07915614E	G5-51
056C262B025L1A	...	056C262B160K1A	...	056C262T009S1A	...	056C350B080LKA	...	056C350S200S1A	...	07915614F	G5-51
..... G5-19	 G5-20	 G5-19	 G5-23	 G5-23		07915614G	G5-51
										07915614H	G5-51

PART NUMBER INDEX



Part No.	Page	Part No.	Page	Part No.	Page	Part No.	Page	Part No.	Page	Part No.	Page
07915614L	G5-51	07920705C	G5-50	13AZ07R56	G4-82	13Q060H56	G4-16	13S30LR	G4-18	140C150B038LKA	
07915614M	G5-51	08692304A	G5-50	13AZ10H56	G4-82	13Q060L56	G4-16	13S30R	G4-18	140C150B040K1A	G5-15
07915614N	G5-51	08693202B	G5-50	13AZ10L56	G4-82	13Q060R56	G4-16	13S40H	G4-18	140C150B040L1A	G5-15
07915614P	G5-51	08693204B	G5-50	13AZ10LR56	G4-82	13Q060R56	G4-16	13S40L	G4-18	140C150B040L1A	G5-15
07915614R	G5-51	08693206B	G5-50	13AZ10R56	G4-82	13QZ05H56	G4-80	13S40LR	G4-18	140C150B040L1A	G5-15
07915614S	G5-51	08693208B	G5-50	13AZ15H56	G4-82	13QZ05L56	G4-80	13S40R	G4-18	140C150B040LKA	G5-15
07915615B	G5-51	08693310A	G5-50	13AZ15L56	G4-82	13QZ05LR56	G4-80	13S50H	G4-18	140C150B040LKA	G5-15
07915615C	G5-51	11631-58-X	G4-127	13AZ15LR56	G4-82	13QZ05R56	G4-80	13S50L	G4-18	140C150B050K1A	G5-15
07915615D	G5-51	1315MTR14	G4-18, G4-24, G4-90	13AZ15R56	G4-82	13QZ07H56	G4-80	13S50LR	G4-18	140C150B050K1A	G5-15
07915615E	G5-51			13AZ20H56	G4-82	13QZ07L56	G4-80	13S50R	G4-18	140C150B050L1A	G5-15
07915615F	G5-51	1315MTR56	G4-18, G4-24, G4-90	13AZ20L56	G4-82	13QZ07LR56	G4-80	13S60H	G4-18	140C150B050L1A	G5-15
07915615G	G5-51			13AZ20LR56	G4-82	13QZ07R56	G4-80	13S60L	G4-18	140C150B050LKA	G5-15
07915615H	G5-51	13A05H14	G4-20	13AZ20R56	G4-82	13QZ10H56	G4-80	13S60LR	G4-18	140C150B050LKA	G5-15
07915615K	G5-51	13A05H56	G4-20	13AZ25H56	G4-82	13QZ10L56	G4-80	13S60R	G4-18	140C150S007S1A	G5-15
07915615L	G5-51	13A05L14	G4-20	13AZ25L56	G4-82	13QZ10LR56	G4-80	13SHAFTREV	G4-107	140C150S009S1A	G5-15
07915615M	G5-51	13A05L56	G4-20	13AZ25LR56	G4-82	13QZ10R56	G4-80		G4-94	140C150S010S1A	G5-15
07915615N	G5-51	13A05LR14	G4-20	13AZ25R56	G4-82	13QZ15H56	G4-80	13TIEROD	G4-94	140C150S015S1A	G5-15
07915615P	G5-51	13A05LR56	G4-20	13AZ30H56	G4-82	13QZ15L56	G4-80	13ZBASE	G4-91	140C150S018S1A	G5-15
07915615R	G5-51	13A05R56	G4-20	13AZ30L56	G4-82	13QZ15LR56	G4-80	13ZRISER	G4-93	140C150S020S1A	G5-15
07915615S	G5-51	13A05RL14	G4-20	13AZ30R56	G4-82	13QZ15R56	G4-80	140C150B007K1A	G5-15	140C150S020S1A	G5-15
07915616A	G5-51	13A07H14	G4-20	13AZ40H56	G4-82	13QZ20H56	G4-80		G5-15	140C150S025S1A	G5-15
07915616B	G5-51	13A07H56	G4-20	13AZ40L56	G4-82	13QZ20L56	G4-80	140C150B007L1A	G5-15	140C150S030S1A	G5-15
07915616C	G5-51	13A07L14	G4-20	13AZ40LR56	G4-82	13QZ20LR56	G4-80		G5-15	140C150S038S1A	G5-15
07915616D	G5-51	13A07L56	G4-20	13AZ40R56	G4-82	13QZ20R56	G4-80	140C150B009L1A	G5-15	140C150S040S1A	G5-15
07915616E	G5-51	13A07LR14	G4-20	13AZ50H56	G4-82	13QZ25H56	G4-80		G5-15	140C150T007S1A	G5-15
07915616F	G5-51	13A07LR56	G4-20	13AZ50L56	G4-82	13QZ25L56	G4-80	140C150B009K1A	G5-15	140C150T009S1A	G5-15
07915616G	G5-51	13A07R56	G4-20	13AZ50LR56	G4-82	13QZ25LR56	G4-80		G5-15	140C150T010S1A	G5-15
07915616H	G5-51	13A07RL14	G4-20	13AZ50R56	G4-82	13QZ25R56	G4-80	140C150B009L1A	G5-15	140C150T015S1A	G5-15
07915616J	G5-51	13A10H14	G4-20	13AZ60H56	G4-82	13QZ30H56	G4-80		G5-15	140C150T018S1A	G5-15
07915616K	G5-51	13A10H56	G4-20	13AZ60L56	G4-82	13QZ30L56	G4-80	140C150B009LKA	G5-15	140C150T020S1A	G5-15
07915616L	G5-51	13A10L14	G4-20	13AZ60LR56	G4-82	13QZ30LR56	G4-80		G5-15	140C150T025S1A	G5-15
07915616M	G5-51	13A10L56	G4-20	13AZ60R56	G4-82	13QZ30R56	G4-80	140C150B010K1A	G5-15	140C150T025S1A	G5-15
07915616N	G5-51	13A10LR14	G4-20	13BASE	G4-91	13QZ40H56	G4-80		G5-15	140C150T038S1A	G5-15
07915616P	G5-51	13A10LR56	G4-20	13BRACKET	G4-102	13QZ40L56	G4-80	140C150B010L1A	G5-15	140C150T040S1A	G5-15
07915616R	G5-51	13A10R56	G4-20	13PLUGIN	G4-103	13QZ40R56	G4-80		G5-15	140C150T040S1A	G5-15
07915616S	G5-51	13A10RL14	G4-20	13Q05H56	G4-16	13QZ40R56	G4-80	140C150B010LKA	G5-15	140C150T070S1A	G5-15
07915819B	G5-51	13A15H56	G4-20	13Q05L56	G4-16	13QZ50H56	G4-80		G5-15	140C150T070S1A	G5-15
07915819C	G5-51	13A15L56	G4-20	13Q05LR56	G4-16	13QZ50L56	G4-80	140C150B015K1A	G5-15	140C150T090S1A	G5-15
07915819D	G5-51	13A15LR56	G4-20	13Q05R56	G4-16	13QZ50LR56	G4-80		G5-15	140C150T105S1A	G5-15
07915819E	G5-51	13A15R56	G4-20	13Q07H56	G4-16	13QZ50R56	G4-80	140C150B015L1A	G5-15	140C150T105S1A	G5-15
07915819F	G5-51	13A20H56	G4-20	13Q07L56	G4-16	13QZ60H56	G4-80		G5-15	140C150T155S1A	G5-15
07915819G	G5-51	13A20L56	G4-20	13Q07LR56	G4-16	13QZ60L56	G4-80	140C150B015LKA	G5-15	140C150T155S1A	G5-15
07915819H	G5-51	13A20LR56	G4-20	13Q07R56	G4-16	13QZ60LR56	G4-80		G5-15	140C150T188S1A	G5-15
07915820C	G5-51	13A20R56	G4-20	13Q10H56	G4-16	13QZ60R56	G4-80	140C150B018K1A	G5-15	140C150T188S1A	G5-15
07915820D	G5-51	13A25H56	G4-20	13Q10L56	G4-16	13RISER	G4-93		G5-15	140C150T205S1A	G5-15
07915820E	G5-51	13A25L56	G4-20	13Q10LR56	G4-16	13S05H	G4-18	140C150B018L1A	G5-15	140C150T205S1A	G5-15
07915820F	G5-51	13A25LR56	G4-20	13Q10R56	G4-16	13S05L	G4-18		G5-15	140C150T205S1A	G5-15
07915820G	G5-51	13A25R56	G4-20	13Q15H56	G4-16	13S05LR	G4-18	140C150B018LKA	G5-15	140C150T205S1A	G5-15
07915820H	G5-51	13A30H56	G4-20	13Q15L56	G4-16	13S05R	G4-18		G5-15	140C150T205S1A	G5-15
07915821B	G5-51	13A30L56	G4-20	13Q15LR56	G4-16	13S07H	G4-18	140C150B020K1A	G5-15	140C150T205S1A	G5-15
07915821M	G5-51	13A30LR56	G4-20	13Q15R56	G4-16	13S07L	G4-18		G5-15	140C150T303S1A	G5-15
07915821N	G5-51	13A30R56	G4-20	13Q20H56	G4-16	13S07LR	G4-18	140C150B020L1A	G5-15	140C150T303S1A	G5-15
07915821P	G5-51	13A40H56	G4-20	13Q20L56	G4-16	13S07R	G4-18		G5-15	140C150T303S1A	G5-15
07915821R	G5-51	13A40L56	G4-20	13Q20LR56	G4-16	13S10H	G4-18	140C150B020LKA	G5-15	140C150T303S1A	G5-15
07915821S	G5-51	13A40LR56	G4-20	13Q20R56	G4-16	13S10L	G4-18		G5-15	140C150T405S1A	G5-15
07915821T	G5-51	13A40R56	G4-20	13Q25H56	G4-16	13S10LR	G4-18	140C150B025K1A	G5-15	140C150T405S1A	G5-15
07915821U	G5-51	13A50H56	G4-20	13Q25L56	G4-16	13S10R	G4-18		G5-15	140C150T405S1A	G5-15
07915822A	G5-51	13A50L56	G4-20	13Q25LR56	G4-16	13S15H	G4-18	140C150B025L1A	G5-15	140C150T405S1A	G5-15
07915822B	G5-51	13A50LR56	G4-20	13Q25R56	G4-16	13S15L	G4-18		G5-15	140C200B009K1A	G5-17
07915822C	G5-51	13A50R56	G4-20	13Q30H56	G4-16	13S15LR	G4-18	140C150B025LKA	G5-15	140C200B009LKA	G5-17
07915822D	G5-51	13A60H56	G4-20	13Q30L56	G4-16	13S15R	G4-18		G5-15	140C200B009L1A	G5-17
07915822E	G5-51	13A60L56	G4-20	13Q30LR56	G4-16	13S20H	G4-18	140C150B030K1A	G5-15	140C200B009L1A	G5-17
07915822F	G5-51	13A60LR56	G4-20	13Q30R56	G4-16	13S20L	G4-18		G5-15	140C200B010K1A	G5-17
07915822G	G5-51	13A60R56	G4-20	13Q40H56	G4-16	13S20LR	G4-18	140C150B030L1A	G5-15	140C200B010K1A	G5-17
07915822H	G5-51	13A205H56	G4-82	13Q40L56	G4-16	13S20R	G4-18		G5-15	140C200B010L1A	G5-17
07920618C	G5-46	13A205L56	G4-82	13Q40LR56	G4-16	13S25H	G4-18	140C150B030LKA	G5-15	140C200B010L1A	G5-17
07920620B	G5-50	13A205LR56	G4-82	13Q40R56	G4-16	13S25L	G4-18		G5-15	140C200B010L1A	G5-17
07920626A	G5-50	13A205R56	G4-82	13Q50H56	G4-16	13S25LR	G4-18	140C150B038K1A	G5-15	140C200B010LKA	G5-17
07920702C	G5-50	13A207H56	G4-82	13Q50L56	G4-16	13S25R	G4-18		G5-15	140C200B010LKA	G5-17
07920703C	G5-50	13A207L56	G4-82	13Q50LR56	G4-16	13S30H	G4-18	140C150B038L1A	G5-15		
07920704C	G5-50	13A207LR56	G4-82	13Q50R56	G4-16	13S30L	G4-18		G5-15		

PART NUMBER INDEX



Part No.	Page	Part No.	Page	Part No.	Page	Part No.	Page	Part No.	Page	Part No.	Page
140C200B015K1A ..	G5-17	140C200B090LKA ..	G5-18	140C262B007L1A ..	G5-19	140C262B075K1A ..	G5-20	140C262S060S1A ..	G5-20	140C350B009K1A ..	G5-22
140C200B015L1A ..	G5-17	140C200B100K1A ..	G5-18	140C262B007LKA ..	G5-19	140C262B075L1A ..	G5-20	140C262S075S1A ..	G5-20	140C350B009L1A ..	G5-22
140C200B015LKA ..	G5-17	140C200B100L1A ..	G5-18	140C262B009K1A ..	G5-19	140C262B075LKA ..	G5-20	140C262S080S1A ..	G5-21	140C350B009LKA ..	G5-22
140C200B018K1A ..	G5-17	140C200B100LKA ..	G5-18	140C262B009LKA ..	G5-19	140C262B080K1A ..	G5-20	140C262S090S1A ..	G5-21	140C350B040K1A ..	G5-22
140C200B018L1A ..	G5-17	140C200S009S1A ..	G5-17	140C262B009LKA ..	G5-19	140C262B080L1A ..	G5-20	140C262S100S1A ..	G5-21	140C350B040L1A ..	G5-22
140C200B018LKA ..	G5-17	140C200S010S1A ..	G5-17	140C262B010K1A ..	G5-19	140C262B080LKA ..	G5-20	140C262S125S1A ..	G5-21	140C350B040LKA ..	G5-22
140C200B020K1A ..	G5-17	140C200S018S1A ..	G5-17	140C262B010LKA ..	G5-19	140C262B090K1A ..	G5-20	140C262S150S1A ..	G5-20	140C350B050K1A ..	G5-22
140C200B020L1A ..	G5-17	140C200S015S1A ..	G5-17	140C262B010L1A ..	G5-19	140C262B090L1A ..	G5-20	140C262S160S1A ..	G5-20	140C350B050L1A ..	G5-22
140C200B020LKA ..	G5-17	140C200S018S1A ..	G5-17	140C262B010LKA ..	G5-19	140C262B090LKA ..	G5-20	140C262S200S1A ..	G5-20	140C350B050LKA ..	G5-22
140C200B025K1A ..	G5-17	140C200S020S1A ..	G5-17	140C262B015K1A ..	G5-19	140C262B100K1A ..	G5-20	140C262T007S1A ..	G5-19	140C350B060K1A ..	G5-23
140C200B025L1A ..	G5-17	140C200S025S1A ..	G5-17	140C262B015L1A ..	G5-19	140C262B100L1A ..	G5-20	140C262T009S1A ..	G5-19	140C350B060L1A ..	G5-23
140C200B025LKA ..	G5-17	140C200S030S1A ..	G5-17	140C262B015LKA ..	G5-19	140C262B100LKA ..	G5-20	140C262T010S1A ..	G5-19	140C350B060LKA ..	G5-23
140C200B030K1A ..	G5-17	140C200S038S1A ..	G5-17	140C262B018K1A ..	G5-19	140C262B125K1A ..	G5-20	140C262T015S1A ..	G5-19	140C350B075K1A ..	G5-23
140C200B030L1A ..	G5-17	140C200S040S1A ..	G5-17	140C262B018L1A ..	G5-19	140C262B125L1A ..	G5-20	140C262T018S1A ..	G5-19	140C350B075L1A ..	G5-23
140C200B030LKA ..	G5-17	140C200S050S1A ..	G5-17	140C262B018LKA ..	G5-19	140C262B125LKA ..	G5-20	140C262T020S1A ..	G5-19	140C350B075LKA ..	G5-23
140C200B038K1A ..	G5-17	140C200S060S1A ..	G5-17	140C262B020K1A ..	G5-19	140C262B150K1A ..	G5-20	140C262T025S1A ..	G5-19	140C350B080K1A ..	G5-23
140C200B038L1A ..	G5-17	140C200S075S1A ..	G5-18	140C262B020L1A ..	G5-19	140C262B150L1A ..	G5-20	140C262T030S1A ..	G5-19	140C350B080L1A ..	G5-23
140C200B038LKA ..	G5-17	140C200S080S1A ..	G5-18	140C262B020LKA ..	G5-19	140C262B150LKA ..	G5-20	140C262T038S1A ..	G5-19	140C350B080LKA ..	G5-23
140C200B040K1A ..	G5-17	140C200S080S1A ..	G5-18	140C262B025K1A ..	G5-19	140C262B160K1A ..	G5-20	140C262T040S1A ..	G5-19	140C350B086K1A ..	G5-23
140C200B040L1A ..	G5-17	140C200S100S1A ..	G5-18	140C262B025L1A ..	G5-19	140C262B160L1A ..	G5-20	140C262T050S1A ..	G5-19	140C350B086L1A ..	G5-23
140C200B040LKA ..	G5-17	140C200T009S1A ..	G5-17	140C262B025LKA ..	G5-19	140C262B160LKA ..	G5-20	140C262T060S1A ..	G5-19	140C350B086LKA ..	G5-23
140C200B050K1A ..	G5-17	140C200T010S1A ..	G5-17	140C262B030K1A ..	G5-19	140C262B160LKA ..	G5-20	140C262T060S1A ..	G5-20	140C350B100K1A ..	G5-23
140C200B050L1A ..	G5-17	140C200T015S1A ..	G5-17	140C262B030L1A ..	G5-19	140C262B200K1A ..	G5-20	140C262T075S1A ..	G5-20	140C350B100L1A ..	G5-23
140C200B050LKA ..	G5-17	140C200T018S1A ..	G5-17	140C262B030LKA ..	G5-19	140C262B200L1A ..	G5-20	140C262T080S1A ..	G5-21	140C350B100LKA ..	G5-23
140C200B060K1A ..	G5-17	140C200T018S1A ..	G5-17	140C262B030LKA ..	G5-19	140C262B200LKA ..	G5-20	140C262T090S1A ..	G5-21	140C350B125K1A ..	G5-23
140C200B060L1A ..	G5-17	140C200T025S1A ..	G5-17	140C262B038K1A ..	G5-19	140C262B200LKA ..	G5-20	140C262T100S1A ..	G5-21	140C350B125L1A ..	G5-23
140C200B060LKA ..	G5-17	140C200T025S1A ..	G5-17	140C262B038L1A ..	G5-19	140C262S007S1A ..	G5-19	140C262T125S1A ..	G5-21	140C350B125LKA ..	G5-23
140C200B075K1A ..	G5-18	140C200T030S1A ..	G5-17	140C262B038LKA ..	G5-19	140C262S009S1A ..	G5-19	140C262T150S1A ..	G5-20	140C350B150K1A ..	G5-23
140C200B075L1A ..	G5-18	140C200T038S1A ..	G5-17	140C262B040K1A ..	G5-19	140C262S010S1A ..	G5-19	140C262T160S1A ..	G5-20	140C350B150L1A ..	G5-23
140C200B075LKA ..	G5-18	140C200T040S1A ..	G5-17	140C262B040L1A ..	G5-19	140C262S015S1A ..	G5-19	140C262T160S1A ..	G5-20	140C350B150LKA ..	G5-23
140C200B080K1A ..	G5-18	140C200T050S1A ..	G5-17	140C262B040LKA ..	G5-19	140C262S018S1A ..	G5-19	140C262T200S1A ..	G5-20	140C350B160L1A ..	G5-23
140C200B080L1A ..	G5-18	140C200T060S1A ..	G5-17	140C262B050K1A ..	G5-19	140C262S020S1A ..	G5-19	140C350B006K1A ..	G5-22	140C350B160K1A ..	G5-23
140C200B080LKA ..	G5-18	140C200T075S1A ..	G5-18	140C262B050L1A ..	G5-19	140C262S025S1A ..	G5-19	140C350B006LKA ..	G5-22	140C350B160LKA ..	G5-23
140C200B090K1A ..	G5-18	140C200T080S1A ..	G5-18	140C262B050LKA ..	G5-19	140C262S030S1A ..	G5-19	140C350B007K1A ..	G5-22	140C350B200K1A ..	G5-23
140C200B090L1A ..	G5-18	140C200T090S1A ..	G5-18	140C262B060K1A ..	G5-20	140C262S038S1A ..	G5-19	140C350B007LKA ..	G5-22	140C350B200L1A ..	G5-23
140C200B090LKA ..	G5-18	140C200T100S1A ..	G5-18	140C262B060LKA ..	G5-20	140C262S040S1A ..	G5-19	140C350B007LKA ..	G5-22	140C350B200L1A ..	G5-23
140C200B100K1A ..	G5-18	140C262B007K1A ..	G5-19	140C262B060LKA ..	G5-20	140C262S050S1A ..	G5-19	140C350B007LKA ..	G5-22	140C350B200L1A ..	G5-23

PART NUMBER INDEX



Part No.	Page	Part No.	Page	Part No.	Page	Part No.	Page	Part No.	Page
140C350B200LKA		140C350T160S1A		15AZ10LR56	G4-82	15Q60LR56	G4-22	15S40H	G4-24
..... G5-23	 G5-23		15AZ10R56	G4-82	15Q60R56	G4-22	15S40L	G4-24
140C350B240K1A		140C350T200S1A		15AZ15H56	G4-82	15QZ05H56	G4-80	15S40LR	G4-24
..... G5-23	 G5-23		15AZ15L56	G4-82	15QZ05L56	G4-80	15S40R	G4-24
140C350B240L1A		140C350T240S1A		15AZ15LR56	G4-82	15QZ05LR56	G4-80	15S50H	G4-24
..... G5-23	 G5-23		15AZ15R56	G4-82	15QZ05R56	G4-80	15S50L	G4-24
140C350B240LKA		140C350T300S1A		15AZ20H56	G4-82	15QZ07H56	G4-80	15S50LR	G4-24
..... G5-23	 G5-23		15AZ20L56	G4-82	15QZ07L56	G4-80	15S50R	G4-24
140C350B300K1A		150182	G5-50	15AZ20LR56	G4-82	15QZ07LR56	G4-80	15S60H	G4-24
..... G5-23		15A05H14	G4-26	15AZ20R56	G4-82	15QZ07R56	G4-80	15S60L	G4-24
140C350B300L1A		15A05H56	G4-26	15AZ25H56	G4-82	15QZ10H56	G4-80	15S60LR	G4-24
..... G5-23		15A05L14	G4-26	15AZ25L56	G4-82	15QZ10L56	G4-80	15S60R	G4-24
140C350B300LKA		15A05L56	G4-26	15AZ25LR56	G4-82	15QZ10LR56	G4-80	15TIEROD	G4-94
..... G5-23		15A05LR14	G4-26	15AZ25R56	G4-82	15QZ10R56	G4-80	15ZBASE	G4-91
140C350S006S1A		15A05LR56	G4-26	15AZ30H56	G4-82	15QZ15H56	G4-80	15ZRISER	G4-93
..... G5-22		15A05R14	G4-26	15AZ30L56	G4-82	15QZ15L56	G4-80	1720MTR14	G4-30,
140C350S007S1A		15A05R56	G4-26	15AZ30LR56	G4-82	15QZ15LR56	G4-80 G4-38,G4-90	
..... G5-22		15A07H14	G4-26	15AZ30R56	G4-82	15QZ15R56	G4-80	1720MTR56	G4-30,
140C350S009S1A		15A07H56	G4-26	15AZ40H56	G4-82	15QZ20H56	G4-80 G4-38,G4-90	
..... G5-22		15A07L14	G4-26	15AZ40L56	G4-82	15QZ20L56	G4-80	17A05H14	G4-32
140C350S040S1A		15A07L56	G4-26	15AZ40LR56	G4-82	15QZ20LR56	G4-80	17A05H56	G4-32
..... G5-22		15A07LR14	G4-26	15AZ40R56	G4-82	15QZ20R56	G4-80	17A05L14	G4-32
140C350S050S1A		15A07LR56	G4-26	15AZ50H56	G4-82	15QZ25H56	G4-80	17A05L14	G4-32
..... G5-22		15A07R14	G4-26	15AZ50L56	G4-82	15QZ25L56	G4-80	17A05LR14	G4-32
140C350S060S1A		15A07R56	G4-26	15AZ50LR56	G4-82	15QZ25LR56	G4-80	17A05LR56	G4-32
..... G5-23		15A10H14	G4-26	15AZ50R56	G4-82	15QZ25R56	G4-80	17A05R14	G4-32
140C350S075S1A		15A10H56	G4-26	15AZ60H56	G4-82	15QZ30H56	G4-80	17A05R56	G4-32
..... G5-23		15A10L14	G4-26	15AZ60L56	G4-82	15QZ30L56	G4-80	17A07H14	G4-32
140C350S080S1A		15A10L56	G4-26	15AZ60LR56	G4-82	15QZ30LR56	G4-80	17A07H56	G4-32
..... G5-23		15A10LR14	G4-26	15AZ60R56	G4-82	15QZ30R56	G4-80	17A07L14	G4-32
140C350S086S1A		15A10LR56	G4-26	15BASE	G4-91	15QZ40H56	G4-80	17A07L56	G4-32
..... G5-23		15A10R14	G4-26	15BRACKET	G4-102	15QZ40L56	G4-80	17A07LR14	G4-32
140C350S100S1A		15A10R56	G4-26	15PLUGIN	G4-103	15QZ40LR56	G4-80	17A07LR56	G4-32
..... G5-23		15A15H56	G4-26	15Q05H56	G4-22	15QZ40R56	G4-80	17A07R14	G4-32
140C350S125S1A		15A15L56	G4-26	15Q05L56	G4-22	15QZ50H56	G4-80	17A07R56	G4-32
..... G5-23		15A15LR56	G4-26	15Q05LR56	G4-22	15QZ50L56	G4-80	17A10H14	G4-32
140C350S150S1A		15A15R56	G4-26	15Q05R56HT	G4-22	15QZ50LR56	G4-80	17A10H56	G4-32
..... G5-23		15A20H56	G4-26	15Q07H56	G4-22	15QZ50R56	G4-80	17A10L14	G4-32
140C350S160S1A		15A20L56	G4-26	15Q07L56	G4-22	15QZ60H56	G4-80	17A10L56	G4-32
..... G5-23		15A20LR56	G4-26	15Q07LR56	G4-22	15QZ60L56	G4-80	17A10LR14	G4-32
140C350S200S1A		15A20R56	G4-26	15Q07R56	G4-22	15QZ60LR56	G4-80	17A10R14	G4-32
..... G5-23		15A25H56	G4-26	15Q10H56	G4-22	15QZ60R56	G4-80	17A10R56	G4-32
140C350S240S1A		15A25L56	G4-26	15Q10L56	G4-22	15RISER	G4-93	17A15H14	G4-32
..... G5-23		15A25LR56	G4-26	15Q10LR56	G4-22	15S05H	G4-24	17A15H56	G4-32
140C350S300S1A		15A25R56	G4-26	15Q10R56	G4-22	15S05L	G4-24	17A15L14	G4-32
..... G5-23		15A30H56	G4-26	15Q15H56	G4-22	15S05LR	G4-24	17A15L56	G4-32
140C350T006S1A		15A30L56	G4-26	15Q15L56	G4-22	15S05R	G4-24	17A15LR14	G4-32
..... G5-22		15A30LR56	G4-26	15Q15LR56	G4-22	15S07H	G4-24	17A15LR56	G4-32
140C350T007S1A		15A30R56	G4-26	15Q15R56	G4-22	15S07L	G4-24	17A15R14	G4-32
..... G5-22		15A40H56	G4-26	15Q20H56	G4-22	15S07R	G4-24	17A15R56	G4-32
140C350T009S1A		15A40L56	G4-26	15Q20L56	G4-22	15S07R	G4-24	17A20H14	G4-32
..... G5-22		15A40LR56	G4-26	15Q20LR56	G4-22	15S10H	G4-24	17A20H56	G4-32
140C350T040S1A		15A40R56	G4-26	15Q20R56	G4-22	15S10L	G4-24	17A20L14	G4-32
..... G5-22		15A50H56	G4-26	15Q25H56	G4-22	15S10LR	G4-24	17A20L56	G4-32
140C350T050S1A		15A50L56	G4-26	15Q25L56	G4-22	15S10R	G4-24	17A20LR14	G4-32
..... G5-22		15A50LR56	G4-26	15Q25LR56	G4-22	15S15H	G4-24	17A20LR56	G4-32
140C350T060S1A		15A50R56	G4-26	15Q25R56	G4-22	15S15L	G4-24	17A20R14	G4-32
..... G5-23		15A60H56	G4-26	15Q30H56	G4-22	15S15LR	G4-24	17A20R56	G4-32
140C350T075S1A		15A60L56	G4-26	15Q30L56	G4-22	15S15R	G4-24	17A25H56	G4-32
..... G5-23		15A60LR56	G4-26	15Q30LR56	G4-22	15S20H	G4-24	17A25L56	G4-32
140C350T080S1A		15A60R56	G4-26	15Q30R56	G4-22	15S20L	G4-24	17A25LR56	G4-32
..... G5-23		15A205H56	G4-82	15Q40H56	G4-22	15S20LR	G4-24	17A25R56	G4-32
140C350T086S1A		15A205L56	G4-82	15Q40L56	G4-22	15S20R	G4-24	17A30H56	G4-32
..... G5-23		15A205LR56	G4-82	15Q40LR56	G4-22	15S25H	G4-24	17A30L56	G4-32
140C350T100S1A		15A205R56	G4-82	15Q40R56	G4-22	15S25L	G4-24	17A30LR56	G4-32
..... G5-23		15A207H56	G4-82	15Q50H56	G4-22	15S25LR	G4-24	17A30R56	G4-32
140C350T125S1A		15A207L56	G4-82	15Q50L56	G4-22	15S25R	G4-24	17A40H56	G4-32
..... G5-23		15A207LR56	G4-82	15Q50LR56	G4-22	15S30H	G4-24	17A40L56	G4-32
140C350T150S1A		15A207R56	G4-82	15Q50R56	G4-22	15S30L	G4-24	17A40LR56	G4-32
..... G5-23		15A210H56	G4-82	15Q60H56	G4-22	15S30LR	G4-24	17A40R56	G4-32
		15A210L56	G4-82	15Q60L56	G4-22	15S30R	G4-24	17A50H56	G4-32

PART NUMBER INDEX



Part No.	Page	Part No.	Page	Part No.	Page	Part No.	Page	Part No.	Page	Part No.	Page
17AZ05LR56	G4-82	17Q07H14	G4-28	17QS07L56	G4-84	17QZ10R14	G4-80	17S50H	G4-30	180C200T018S1A	G5-17
17AZ05R14	G4-82	17Q07H56	G4-28	17QS07LR14	G4-84	17QZ10R56	G4-80	17S50L	G4-30	180C200T020S1A	G5-17
17AZ05R56	G4-82	17Q07L14	G4-28	17QS07LR56	G4-84	17QZ15H14	G4-80	17S50LR	G4-30	180C200T025S1A	G5-17
17AZ07H14	G4-82	17Q07L56	G4-28	17QS07R14	G4-84	17QZ15H56	G4-80	17S50R	G4-30	180C262B007K1A	G5-19
17AZ07H56	G4-82	17Q07LR14	G4-28	17QS07R56	G4-84	17QZ15L14	G4-80	17S60H	G4-30	180C262B007L1A	G5-19
17AZ07L14	G4-82	17Q07LR56	G4-28	17QS10H14	G4-84	17QZ15L56	G4-80	17S60L	G4-30	180C262B009K1A	G5-19
17AZ07L56	G4-82	17Q07R14	G4-28	17QS10H56	G4-84	17QZ15LR14	G4-80	17S60LR	G4-30	180C262B010K1A	G5-19
17AZ07LR14	G4-82	17Q07R56	G4-28	17QS10L14	G4-84	17QZ15LR56	G4-80	17S60R	G4-30	180C262B010L1A	G5-19
17AZ07LR56	G4-82	17Q10H14	G4-28	17QS10L56	G4-84	17QZ15R14	G4-80	17SBASE	G4-91	180C262B015K1A	G5-19
17AZ07R14	G4-82	17Q10H56	G4-28	17QS10LR14	G4-84	17QZ15R56	G4-80	17SFLANGE	G4-95	180C262B015L1A	G5-19
17AZ07R56	G4-82	17Q10L14	G4-28	17QS10LR56	G4-84	17QZ20H14	G4-80	17SHAFTREV	G4-107	180C262B020K1A	G5-19
17AZ10H14	G4-82	17Q10L56	G4-28	17QS10R14	G4-84	17QZ20H56	G4-80	17TIEROD	G4-94	180C262B025K1A	G5-19
17AZ10H56	G4-82	17Q10LR14	G4-28	17QS10R56	G4-84	17QZ20L14	G4-80	17TZBASE	G4-91	180C262B030K1A	G5-19
17AZ10L14	G4-82	17Q10LR56	G4-28	17QS15H14	G4-84	17QZ20L56	G4-80	17ZFLANGE	G4-95	180C262B035K1A	G5-19
17AZ10L56	G4-82	17Q10R14	G4-28	17QS15H56	G4-84	17QZ20LR14	G4-80	17ZRISER	G4-93	180C262B040K1A	G5-19
17AZ10LR14	G4-82	17Q10R56	G4-28	17QS15L14	G4-84	17QZ20LR56	G4-80	180C200B009K1A	G5-17	180C262B045K1A	G5-19
17AZ10LR56	G4-82	17Q15H14	G4-28	17QS15L56	G4-84	17QZ20R14	G4-80	180C200B009L1A	G5-17	180C262B050K1A	G5-19
17AZ10R14	G4-82	17Q15H56	G4-28	17QS15LR14	G4-84	17QZ20R56	G4-80	180C200B009LKA	G5-17	180C262B055K1A	G5-19
17AZ10R56	G4-82	G4-28, G4-86		17QS15LR56	G4-84	17QZ25H56	G4-80	180C200B010K1A	G5-17	180C262B060K1A	G5-19
17AZ15H14	G4-82	17Q15L14	G4-28	17QS15R14	G4-84	17QZ25L56	G4-80	180C200B010L1A	G5-17	180C262B065K1A	G5-19
17AZ15H56	G4-82	17Q15L56	G4-28	17QS15R56	G4-84	17QZ25LR56	G4-80	180C200B010LKA	G5-17	180C262B070K1A	G5-19
17AZ15L14	G4-82	G4-28, G4-86		17QS20H14	G4-84	17QZ25R56	G4-80	180C200B010LKA	G5-17	180C262B075K1A	G5-19
17AZ15L56	G4-82	17Q15LR14	G4-28	17QS20H56	G4-84	17QZ30H56	G4-80	180C200B010LKA	G5-17	180C262B080K1A	G5-19
17AZ15LR14	G4-82	17Q15LR56	G4-28	17QS20L14	G4-84	17QZ30L56	G4-80	180C200B010LKA	G5-17	180C262B085K1A	G5-19
17AZ15LR56	G4-82	G4-86		17QS20L56	G4-84	17QZ30LR56	G4-80	180C200B010LKA	G5-17	180C262B090K1A	G5-19
17AZ15R14	G4-82	17Q15R14	G4-28	17QS20LR14	G4-84	17QZ30R56	G4-80	180C200B015K1A	G5-17	180C262B095K1A	G5-19
17AZ15R56	G4-82	17Q15R56	G4-28	17QS20LR56	G4-84	17QZ40H56	G4-80	180C200B015L1A	G5-17	180C262B100K1A	G5-19
17AZ20H14	G4-82	G4-28, G4-86		17QS20R14	G4-84	17QZ40L56	G4-80	180C200B015L1A	G5-17	180C262B105K1A	G5-19
17AZ20H56	G4-82	17Q20H14	G4-28	17QS20R56	G4-84	17QZ40LR56	G4-80	180C200B015LKA	G5-17	180C262B110K1A	G5-19
17AZ20L14	G4-82	17Q20H56	G4-28	17QS25H56	G4-84	17QZ40R56	G4-80	180C200B015LKA	G5-17	180C262B115K1A	G5-19
17AZ20L56	G4-82	G4-28, G4-86		17QS25L56	G4-84	17QZ50H56	G4-80	180C200B015LKA	G5-17	180C262B120K1A	G5-19
17AZ20LR14	G4-82	17Q20L14	G4-28	17QS25LR56	G4-84	17QZ50L56	G4-80	180C200B015LKA	G5-17	180C262B125K1A	G5-19
17AZ20LR56	G4-82	17Q20L56	G4-28	17QS25R56	G4-84	17QZ50LR56	G4-80	180C200B015LKA	G5-17	180C262B130K1A	G5-19
17AZ20R14	G4-82	G4-28, G4-86		17QS30H56	G4-84	17QZ50R56	G4-80	180C200B018K1A	G5-17	180C262B135K1A	G5-19
17AZ20R56	G4-82	17Q20LR14	G4-28	17QS30L56	G4-84	17QZ60H56	G4-80	180C200B018K1A	G5-17	180C262B140K1A	G5-19
17AZ25H14	G4-82	17Q20LR56	G4-28	17QS30LR56	G4-84	17QZ60L56	G4-80	180C200B018K1A	G5-17	180C262B145K1A	G5-19
17AZ25H56	G4-82	G4-86		17QS30R56	G4-84	17QZ60LR56	G4-80	180C200B018L1A	G5-17	180C262B150K1A	G5-19
17AZ25L14	G4-82	17Q20R14	G4-28	17QS40H56	G4-84	17QZ60R56	G4-80	180C200B020K1A	G5-17	180C262B155K1A	G5-19
17AZ25L56	G4-82	17Q20R56	G4-28	17QS40L56	G4-84	17RISER	G4-93	180C200B020K1A	G5-17	180C262B160K1A	G5-19
17AZ25LR56	G4-82	G4-28, G4-86		17QS40LR56	G4-84	17S05H	G4-30	180C200B020K1A	G5-17	180C262B165K1A	G5-19
17AZ25R14	G4-82	17Q25H56	G4-28	17QS40R56	G4-84	17S05L	G4-30	180C200B020L1A	G5-17	180C262B170K1A	G5-19
17AZ25R56	G4-82	17Q25L56	G4-28	17QS50H56	G4-84	17S05LR	G4-30	180C200B020L1A	G5-17	180C262B175K1A	G5-19
17AZ30H56	G4-82	17Q25LR56	G4-28	17QS50L56	G4-84	17S05R	G4-30	180C200B025K1A	G5-17	180C262B180K1A	G5-19
17AZ30H56	G4-82	17Q25R56	G4-28	17QS50LR56	G4-84	17S07H	G4-30	180C200B025K1A	G5-17	180C262B185K1A	G5-19
17AZ30L14	G4-82	17Q30H56	G4-28	17QS50R56	G4-84	17S07L	G4-30	180C200B025L1A	G5-17	180C262B190K1A	G5-19
17AZ30L56	G4-82	17Q30L56	G4-28	17QS60H56	G4-84	17S07LR	G4-30	180C200B025L1A	G5-17	180C262B195K1A	G5-19
17AZ30LR56	G4-82	17Q30LR56	G4-28	17QS60L56	G4-84	17S07R	G4-30	180C200B025L1A	G5-17	180C262B200K1A	G5-19
17AZ30R56	G4-82	17Q30R56	G4-28	17QS60LR56	G4-84	17S10H	G4-30	180C200B025L1A	G5-17	180C262B205K1A	G5-19
17AZ35H14	G4-82	17Q40H56	G4-28	17QS60R56	G4-84	17S10L	G4-30	180C200B025L1A	G5-17	180C262B210K1A	G5-19
17AZ35H56	G4-82	17Q40L56	G4-28	17QS60R56	G4-84	17S10LR	G4-30	180C200B025L1A	G5-17	180C262B215K1A	G5-19
17AZ35L14	G4-82	17Q40LR56	G4-28	17QZ05H14	G4-80	17S10R	G4-30	180C200B025L1A	G5-17	180C262B220K1A	G5-19
17AZ35L56	G4-82	17Q40LR56	G4-28	17QZ05H56	G4-80	17S10R	G4-30	180C200B025L1A	G5-17	180C262B225K1A	G5-19
17AZ35LR56	G4-82	17Q40R56	G4-28	17QZ05L14	G4-80	17S15H	G4-30	180C200B025L1A	G5-17	180C262B230K1A	G5-19
17AZ35R14	G4-82	17Q50H56	G4-28	17QZ05L56	G4-80	17S15L	G4-30	180C200S009S1A	G5-17	180C262B235K1A	G5-19
17AZ35R56	G4-82	17Q50L56	G4-28	17QZ05LR14	G4-80	17S15LR	G4-30	180C200S009S1A	G5-17	180C262B240K1A	G5-19
17BASE	G4-91	17Q50LR56	G4-28	17QZ05LR56	G4-80	17S15R	G4-30	180C200S010S1A	G5-17	180C262B245K1A	G5-19
17BRACKET	G4-102	17Q50R56	G4-28	17QZ05R14	G4-80	17S20H	G4-30	180C200S010S1A	G5-17	180C262B250K1A	G5-19
17CLSDCOVER	G4-108	17Q60H56	G4-28	17QZ05R56	G4-80	17S20L	G4-30	180C200S015S1A	G5-17	180C262B255K1A	G5-19
17FLANGE	G4-95	17Q60L56	G4-28	17QZ07H14	G4-80	17S20LR	G4-30	180C200S015S1A	G5-17	180C262B260K1A	G5-19
17OPENCOVER	G4-108	17Q60LR56	G4-28	17QZ07H56	G4-80	17S20R	G4-30	180C200S018S1A	G5-17	180C262B265K1A	G5-19
17PLUGIN	G4-103	17Q60R56	G4-28	17QZ07L14	G4-80	17S25H	G4-30	180C200S018S1A	G5-17	180C262B270K1A	G5-19
17Q05H14	G4-28	17QS05H14	G4-84	17QZ07L56	G4-80	17S25L	G4-30	180C200S020S1A	G5-17	180C262B275K1A	G5-19
17Q05H56	G4-28	17QS05H56	G4-84	17QZ07LR14	G4-80	17S25LR	G4-30	180C200S020S1A	G5-17	180C262B280K1A	G5-19
17Q05L14	G4-28	17QS05L14	G4-84	17QZ07LR56	G4-80	17S25R	G4-30	180C200S025S1A	G5-17	180C262B285K1A	G5-19
17Q05L56	G4-28	17QS05L56	G4-84	17QZ07R14	G4-80	17S30H	G4-30	180C200S025S1A	G5-17	180C262B290K1A	G5-19
17Q05LR14	G4-28	17QS05LR14	G4-84	17QZ07R56	G4-80	17S30L	G4-30	180C200T009S1A	G5-17	180C262B295K1A	G5-19
17Q05LR56	G4-28	17QS05LR56	G4-84	17QZ10H14	G4-80	17S30LR	G4-30	180C200T009S1A	G5-17	180C262B300K1A	G5-19
17Q05R14	G4-28	17QS05R14	G4-84	17QZ10H56	G4-80	17S30R	G4-30	180C200T010S1A	G5-17	180C262B305K1A	G5-19
17Q05R56	G4-28	17QS05R56	G4-84	17QZ10L14	G4-80	17S40H	G4-30	180C200T010S1A	G5-17	180C262B310K1A	G5-19
17Q05R56	G4-28	17QS07H14	G4-84	17QZ10L56	G4-80	17S40L	G4-30	180C200T015S1A	G5-17	180C262B315K1A	G5-19
17Q05R14	G4-28	17QS07H56	G4-84	17QZ10LR14	G4-80	17S40LR	G4-30	180C200T015S1A	G5-17	180C262B320K1A	G5-19
17Q05R56	G4-28	17QS07L14	G4-84	17QZ10LR56	G4-80	17S40R	G4-30	180C200T015S1A	G5-17	180C262B325K1A	G5-19

PART NUMBER INDEX



Part No.	Page	Part No.	Page	Part No.	Page	Part No.	Page	Part No.	Page
180C262S007S1A		180C350B015L1A		180C350B100K1A		180C350T025S1A		20A15H56	G4-40
..... G5-19	 G5-22	 G5-23	 G5-22		20A15HA14	G4-40, G4-97
180C262S009S1A		180C350B015LKA		180C350B100L1A		180C350T030S1A		20A15HA56	G4-40, G4-97
..... G5-19	 G5-22	 G5-23	 G5-22		20A15LR56	G4-40, G4-97
180C262S010S1A		180C350B018K1A		180C350B100LKA		180C350T038S1A		20A15L14	G4-40
..... G5-19	 G5-22	 G5-23	 G5-22		20A15L56	G4-40
180C262S015S1A		180C350B018L1A		180C350B125K1A		180C350T040S1A		20A15LR14	G4-40
..... G5-19	 G5-22	 G5-23	 G5-22		20A15R56	G4-40
180C262S018S1A		180C350B018LKA		180C350B125L1A		180C350T050S1A		20A15R14	G4-40
..... G5-19	 G5-22	 G5-23	 G5-22		20A15RH56	G4-40
180C262S020S1A		180C350B020K1A		180C350B125LKA		180C350T060S1A		20A15R56	G4-40
..... G5-19	 G5-22	 G5-23	 G5-23		20A18H14	G4-40
180C262S025S1A		180C350B020L1A		180C350B150K1A		180C350T075S1A		20A18H56	G4-40
..... G5-19	 G5-22	 G5-23	 G5-23		20A18HA14	G4-40
180C262S030S1A		180C350B020K1A		180C350B150L1A		180C350T080S1A		20A18HA56	G4-40
..... G5-19	 G5-22	 G5-23	 G5-23		20A18L14	G4-40
180C262S038S1A		180C350B025K1A		180C350B150LKA		180C350T086S1A		20A18L56	G4-40
..... G5-19	 G5-22	 G5-23	 G5-23		20A18LR14	G4-40
180C262S040S1A		180C350B025L1A		180C350S006S1A		180C350T100S1A		20A18LR56	G4-40
..... G5-19	 G5-22	 G5-22	 G5-23		20A18R14	G4-40
180C262S050S1A		180C350B025LKA		180C350S007S1A		180C350T125S1A		20A18R56	G4-40
..... G5-19	 G5-22	 G5-22	 G5-23		20A20H14	G4-40
180C262T007S1A		180C350B030K1A		180C350S009S1A		180C350T150S1A		20A20H56	G4-40
..... G5-19	 G5-22	 G5-22	 G5-23		20A20HA14	G4-40, G4-97
180C262T009S1A		180C350B030L1A		180C350S010S1A		20A05H14	G4-40	20A20HA56	G4-40, G4-97
..... G5-19	 G5-22	 G5-22		20A05H56	G4-40	20A20LR56	G4-40
180C262T010S1A		180C350B030LKA		180C350S015S1A		20A05HA14	G4-40, G4-97	20A20L14	G4-40
..... G5-19	 G5-22	 G5-22		20A05HA56	G4-40, G4-97	20A20L56	G4-40
180C262T015S1A		180C350B038K1A		180C350S018S1A		20A05HA56	G4-40, G4-97	20A20LR14	G4-40
..... G5-19	 G5-22	 G5-22		20A05L14	G4-40	20A20LR56	G4-40
180C262T018S1A		180C350B038L1A		180C350S020S1A		20A05L56	G4-40	20A20R14	G4-40
..... G5-19	 G5-22	 G5-22		20A05LR14	G4-40	20A20R56	G4-40
180C262T020S1A		180C350B038LKA		180C350S025S1A		20A05LR56	G4-40	20A25H14	G4-40
..... G5-19	 G5-22	 G5-22		20A05R14	G4-40	20A25H56	G4-40
180C262T025S1A		180C350B040K1A		180C350S030S1A		20A05R56	G4-40	20A25HA14	G4-40, G4-97
..... G5-19	 G5-22	 G5-22		20A07H14	G4-40	20A25HA56	G4-40, G4-97
180C262T030S1A		180C350B040L1A		180C350S038S1A		20A07H56	G4-40	20A25LR14	G4-40
..... G5-19	 G5-22	 G5-22		20A07HA14	G4-40, G4-97	20A25LR56	G4-40
180C262T038S1A		180C350B040LKA		180C350S040S1A		20A07HA56	G4-40, G4-97	20A25R14	G4-40
..... G5-19	 G5-22	 G5-22		20A07HA56	G4-40, G4-97	20A25R56	G4-40
180C262T040S1A		180C350B050K1A		180C350S050S1A		20A07L14	G4-40	20A25R56	G4-40
..... G5-19	 G5-22	 G5-22		20A07LR14	G4-40	20A30H56	G4-40
180C262T050S1A		180C350B050L1A		180C350S060S1A		20A07LR56	G4-40	20A30HA56	G4-40, G4-97
..... G5-19	 G5-22	 G5-23		20A07R14	G4-40	20A30LR56	G4-40
180C350B006K1A		180C350B050LKA		180C350S075S1A		20A07R56	G4-40	20A30R56	G4-40
..... G5-22	 G5-22	 G5-23		20A10H14	G4-40	20A30R56	G4-40
180C350B006L1A		180C350B060K1A		180C350S080S1A		20A10H56	G4-40	20A40H56	G4-40
..... G5-22	 G5-23	 G5-23		20A10HA14	G4-40, G4-97	20A40HA56	G4-40, G4-97
180C350B006LKA		180C350B060L1A		180C350S086S1A		20A10HA56	G4-40, G4-97	20A40L56	G4-40
..... G5-22	 G5-23	 G5-23		20A10L14	G4-40	20A40L56	G4-40
180C350B007K1A		180C350B060LKA		180C350S100S1A		20A10L56	G4-40	20A40R56	G4-40
..... G5-22	 G5-23	 G5-23		20A10LR14	G4-40	20A50H56	G4-40
180C350B007L1A		180C350B075K1A		180C350S125S1A		20A10LR56	G4-40	20A50HA56	G4-40, G4-97
..... G5-22	 G5-23	 G5-23		20A10R14	G4-40	20A50L56	G4-40
180C350B007LKA		180C350B075L1A		180C350S150S1A		20A10R56	G4-40	20A50LR56	G4-40
..... G5-22	 G5-23	 G5-23		20A12H14	G4-40	20A50R56	G4-40
180C350B009K1A		180C350B075LKA		180C350T006S1A		20A12H56	G4-40	20A60H56	G4-40
..... G5-22	 G5-23	 G5-22		20A12HA14	G4-40	20A60HA56	G4-40, G4-97
180C350B009L1A		180C350B080K1A		180C350T007S1A		20A12HA56	G4-40	20A60L56	G4-40
..... G5-22	 G5-23	 G5-22		20A12L14	G4-40	20A60LR56	G4-40
180C350B009LKA		180C350B080L1A		180C350T009S1A		20A12L56	G4-40	20A60R56	G4-40
..... G5-22	 G5-23	 G5-22		20A12LR14	G4-40	20A60R56	G4-40
180C350B010K1A		180C350B080LKA		180C350T010S1A		20A12R14	G4-40	20A60R56	G4-40
..... G5-22	 G5-23	 G5-22		20A12R56	G4-40	20A60R56	G4-40
180C350B010L1A		180C350B086K1A		180C350T015S1A		20A12R56	G4-40	20A60R56	G4-40
..... G5-22	 G5-23	 G5-22		20A12R56	G4-40	20A60R56	G4-40
180C350B010LKA		180C350B086L1A		180C350T018S1A		20A12R56	G4-40	20A60R56	G4-40
..... G5-22	 G5-23	 G5-22		20A12R56	G4-40	20A60R56	G4-40
180C350B015K1A		180C350B086LKA		180C350T020S1A		20A12R56	G4-40	20A60R56	G4-40
..... G5-22	 G5-23	 G5-22		20A12R56	G4-40	20A60R56	G4-40

PART NUMBER INDEX



Part No.	Page	Part No.	Page	Part No.	Page	Part No.	Page	Part No.	Page	Part No.	Page
20AZ50LR56	G4-82	20Q15L56	G4-36	20Q50R56	G4-36	20QZ30R56	G4-80	20S40HA	G4-38	210C350B025L1A	G5-22
20AZ50R56	G4-82		G4-86	20Q60H56	G4-36	20QZ40H56	G4-80		G4-97		G5-22
20AZ60H56	G4-82	20Q15LR14	G4-36	20Q60HA56	G4-36	20QZ40HA56	G4-80	20S40L	G4-38	210C350B030K1A	G5-22
20AZ60HA56	G4-82	20Q15LR56	G4-36		G4-97	20QZ40L56	G4-80	20S40LR	G4-38		G5-22
20AZ60L56	G4-82		G4-86	20Q60L56	G4-36	20QZ40LR56	G4-80	20S40R	G4-38	210C350B030L1A	G5-22
20AZ60LR56	G4-82	20Q15R14	G4-36	20Q60LR56	G4-36	20QZ40R56	G4-80	20S50H	G4-38		G5-22
20AZ60R56	G4-82	20Q15R56	G4-36	20Q60R56	G4-36	20QZ50H56	G4-80	20S50HA	G4-38	210C350B030LKA	G5-22
20BASE	G4-42		G4-86	20QZ05H14	G4-80	20QZ50HA56	G4-80		G4-97		G5-22
	G4-91	20Q18H14	G4-36	20QZ05H56	G4-80	20QZ50L56	G4-80	20S50L	G4-38	210C350B038K1A	G5-22
20BRACKET	G4-102	20Q18H56	G4-36	20QZ05HA14	G4-80	20QZ50LR56	G4-80	20S50LR	G4-38		G5-22
20BUSH100	G4-96	20Q18HA14	G4-36	20QZ05HA56	G4-80	20QZ50R56	G4-80	20S50R	G4-38	210C350B038L1A	G5-22
20CLSDCOVER	G4-108	20Q18HA56	G4-36	20QZ05L14	G4-80	20QZ60H56	G4-80	20S60H	G4-38		G5-22
	G4-108	20Q18L14	G4-36	20QZ05L56	G4-80	20QZ60HA56	G4-80	20S60HA	G4-38	210C350B038LKA	G5-22
20FLANGE	G4-95	20Q18L56	G4-36	20QZ05LR14	G4-80	20QZ60L56	G4-80		G4-97		G5-22
20OPENCOVER	G4-108	20Q18LR14	G4-36	20QZ05LR56	G4-80	20QZ60LR56	G4-80	20S60L	G4-38	210C350S006S1A	G5-22
	G4-108	20Q18LR56	G4-36	20QZ05R14	G4-80	20QZ60R56	G4-80	20S60LR	G4-38		G5-22
20PLUGIN	G4-103	20Q18R14	G4-36	20QZ05R56	G4-80	20RISER	G4-93	20S60R	G4-38	210C350S007S1A	G5-22
20Q05H14	G4-36	20Q18R56	G4-36	20QZ07H14	G4-80	20S05H	G4-38	20SBUSH100	G4-96		G5-22
20Q05H56	G4-36	20Q20H14	G4-36	20QZ07H56	G4-80	20S05HA	G4-38	20SHAFTREV	G4-107	210C350S009S1A	G5-22
20Q05HA14	G4-36	20Q20H56	G4-36	20QZ07HA14	G4-80		G4-97		G4-107		G5-22
	G4-97		G4-86	20QZ07HA56	G4-80	20S05L	G4-38	20TIEROD	G4-94	210C350S010S1A	G5-22
20Q05HA56	G4-36	20Q20HA14	G4-36	20QZ07L14	G4-80	20S05LR	G4-38	20ZBASE	G4-91		G5-22
	G4-97		G4-97	20QZ07L56	G4-80	20S05R	G4-38	20ZFLANGE	G4-95	210C350S015S1A	G5-22
20Q05L14	G4-36	20Q20HA56	G4-36	20QZ07LR14	G4-80	20S07H	G4-38	20ZRISER	G4-93		G5-22
20Q05L56	G4-36		G4-97	20QZ07LR56	G4-80	20S07HA	G4-38	210C350B006K1A	G4-38	210C350S018S1A	G5-22
20Q05LR14	G4-36	20Q20L14	G4-36	20QZ07R14	G4-80		G4-97		G4-97		G5-22
20Q05LR56	G4-36	20Q20L56	G4-36	20QZ07R56	G4-80	20S07L	G4-38	210C350B006L1A	G4-38	210C350S020S1A	G5-22
20Q05R14	G4-36	20Q20L56	G4-86	20QZ10H14	G4-80	20S07LR	G4-38		G5-22		G5-22
20Q05R56	G4-36	20Q20LR14	G4-36	20QZ10H56	G4-80	20S07R	G4-38	210C350B006LKA	G4-38	210C350S025S1A	G5-22
20Q07H14	G4-36	20Q20LR56	G4-36	20QZ10HA14	G4-80	20S10H	G4-38		G5-22		G5-22
20Q07H56	G4-36		G4-86	20QZ10HA56	G4-80	20S10HA	G4-38	210C350B007K1A	G4-38	210C350S030S1A	G5-22
20Q07HA14	G4-36	20Q20R14	G4-36	20QZ10L14	G4-80		G4-97		G5-22		G5-22
	G4-97	20Q20R56	G4-36	20QZ10L56	G4-80	20S10L	G4-38	210C350B007L1A	G4-38	210C350S038S1A	G5-22
20Q07HA56	G4-36		G4-86	20QZ10LR14	G4-80	20S10LR	G4-38		G5-22		G5-22
	G4-97	20Q25H14	G4-36	20QZ10LR56	G4-80	20S10R	G4-38	210C350B007LKA	G4-38	210C350T006S1A	G5-22
20Q07L14	G4-36	20Q25H56	G4-36	20QZ10R14	G4-80	20S12H	G4-38		G5-22		G5-22
20Q07L56	G4-36		G4-86	20QZ10R56	G4-80	20S12HA	G4-38	210C350B009K1A	G4-38	210C350T007S1A	G5-22
20Q07LR14	G4-36	20Q25HA14	G4-36	20QZ15H14	G4-80	20S12L	G4-38		G5-22		G5-22
20Q07LR56	G4-36		G4-97	20QZ15H56	G4-80	20S12LR	G4-38	210C350B009L1A	G4-38	210C350T009S1A	G5-22
20Q07R14	G4-36	20Q25HA56	G4-36	20QZ15HA14	G4-80	20S12R	G4-38		G5-22		G5-22
20Q07R56	G4-36		G4-97	20QZ15HA56	G4-80	20S15H	G4-38	210C350B009LKA	G4-38	210C350T010S1A	G5-22
20Q10H14	G4-36	20Q25L14	G4-36	20QZ15L14	G4-80	20S15HA	G4-38		G5-22		G5-22
20Q10H56	G4-36	20Q25L56	G4-36	20QZ15L56	G4-80		G4-97	210C350B010K1A	G4-38	210C350T015S1A	G5-22
20Q10HA14	G4-36		G4-86	20QZ15LR14	G4-80	20S15L	G4-38		G5-22		G5-22
	G4-97	20Q25LR14	G4-36	20QZ15LR56	G4-80	20S15LR	G4-38	210C350B010L1A	G4-38	210C350T018S1A	G5-22
20Q10HA56	G4-36	20Q25LR56	G4-36	20QZ15R14	G4-80	20S15R	G4-38		G5-22		G5-22
	G4-97		G4-86	20QZ15R56	G4-80	20S18H	G4-38	210C350B010LKA	G4-38	210C350T020S1A	G5-22
20Q10L14	G4-36	20Q25R14	G4-36	20QZ20H14	G4-80	20S18HA	G4-38		G5-22		G5-22
20Q10L56	G4-36	20Q25R56	G4-36	20QZ20H56	G4-80	20S18L	G4-38	210C350B015K1A	G4-38	210C350T025S1A	G5-22
20Q10LR14	G4-36		G4-86	20QZ20HA14	G4-80	20S18LR	G4-38		G5-22		G5-22
20Q10LR56	G4-36	20Q30H56	G4-36	20QZ20HA56	G4-80	20S18R	G4-38	210C350B015L1A	G4-38	210C350T030S1A	G5-22
20Q10R14	G4-36		G4-86	20QZ20L14	G4-80	20S20H	G4-38		G5-22		G5-22
20Q10R56	G4-36	20Q30HA56	G4-36	20QZ20L56	G4-80	20S20HA	G4-38	210C350B015LKA	G4-38	210C350T038S1A	G5-22
20Q12H14	G4-36		G4-97	20QZ20LR14	G4-80		G4-97		G5-22		G5-22
20Q12H56	G4-36	20Q30L56	G4-36	20QZ20LR56	G4-80	20S20L	G4-38	210C350B018K1A	G4-38	2326BUSH100	G4-96
20Q12HA14	G4-36		G4-86	20QZ20R14	G4-80	20S20LR	G4-38		G5-22		G4-96
20Q12HA56	G4-36	20Q30LR56	G4-36	20QZ20R56	G4-80	20S20R	G4-38	210C350B018L1A	G4-38	2326BUSH103	G4-96
	G4-36		G4-86	20QZ25H14	G4-80	20S25H	G4-38		G5-22		G4-96
20Q12L14	G4-36	20Q30R56	G4-36	20QZ25H56	G4-80	20S25HA	G4-38	210C350B018LKA	G4-38	2326BUSH104	G4-96
20Q12L56	G4-36		G4-86	20QZ25HA14	G4-80		G4-97		G5-22		G4-96
20Q12LR14	G4-36	20Q40H56	G4-36	20QZ25HA56	G4-80	20S25L	G4-38	210C350B020K1A	G4-38	2326FLANGE	G4-95
20Q12LR56	G4-36	20Q40HA56	G4-36	20QZ25L14	G4-80	20S25LR	G4-38		G5-22		G4-95
20Q12R14	G4-36		G4-97	20QZ25L56	G4-80	20S25R	G4-38	210C350B020L1A	G4-38	2326SBUSH100	G4-96
20Q12R56	G4-36	20Q40L56	G4-36	20QZ25LR14	G4-80	20S30H	G4-38		G5-22		G4-96
20Q15H14	G4-36	20Q40LR56	G4-36	20QZ25LR56	G4-80	20S30HA	G4-38	210C350B020LKA	G4-38	2326SBUSH103	G4-96
20Q15H56	G4-36		G4-86	20QZ25R14	G4-80		G4-97		G5-22		G4-96
	G4-86	20Q40R56	G4-36	20QZ25R56	G4-80	20S30L	G4-38	210C350B025K1A	G4-38	2326SBUSH104	G4-96
20Q15HA14	G4-36	20Q50H56	G4-36	20QZ30H56	G4-80	20S30LR	G4-38		G5-22		G4-96
	G4-97	20Q50HA56	G4-36	20QZ30H56	G4-80	20S30R	G4-38	210C350B025KLA	G4-38	2326SPACER	G4-91
20Q15HA56	G4-36		G4-97	20QZ30HA56	G4-80	20S40H	G4-38		G5-22		G4-91
	G4-97	20Q50L56	G4-36	20QZ30L56	G4-80						
20Q15L14	G4-36	20Q50LR56	G4-36								

PART NUMBER INDEX



Part No.	Page	Part No.	Page	Part No.	Page	Part No.	Page	Part No.	Page	Part No.	Page
2326ZFLANGE	...	23A12L14	G4-48	23A50HA56	G4-48,	23AS20L56	G4-85	23AZ07LR56	G4-82	23AZ50L56	G4-82
...	G4-95	23A12L18	G4-48	...	G4-97	23AS20LR14	G4-85	23AZ07R14	G4-82	23AZ50LR56	G4-82
2330MTR14	G4-46,	23A12L56	G4-48	23A50L56	G4-48	23AS20LR56	G4-85	23AZ07R18	G4-82	23AZ50R56	G4-82
...	G4-52, G4-58,	23A12LR14	G4-48	23A50LR56	G4-48	23AS20R14	G4-85	23AZ07R56	G4-82	23AZ60H56	G4-82
...	G4-90	23A12LR18	G4-48	23A50R56	G4-48	23AS20R56	G4-85	23AZ10H14	G4-82	23AZ60HA56	G4-82
2330MTR18	G4-46,	23A12LR56	G4-48	23A60H56	G4-48	23AS25H14	G4-85	23AZ10H18	G4-82	23AZ60L56	G4-82
...	G4-52, G4-58,	23A12R14	G4-48	23A60HA56	G4-48,	23AS25H56	G4-85	23AZ10H56	G4-82	23AZ60LR56	G4-82
...	G4-90	23A12R18	G4-48	...	G4-97	23AS25HA14	G4-85	23AZ10HA14	G4-82	23AZ60R56	G4-82
2330MTR56	G4-46,	23A12R56	G4-48	23A60L56	G4-48	23AS25HA56	G4-85	23AZ10HA18	G4-82	23BASE	G4-91
...	G4-52, G4-58,	23A15H14	G4-48	23A60LR56	G4-48	23AS25L14	G4-85	23AZ10HA56	G4-82	23BRACKET	...
...	G4-90	23A15H56	G4-48	23A60R56	G4-48	23AS25L56	G4-85	23AZ10L14	G4-82	...	G4-102
23A05H14	G4-48	23A15R14	G4-48	23AS05H14	G4-85	23AS25LR14	G4-85	23AZ10L18	G4-82	23CLSDCOVER	...
23A05H18	G4-48	...	G4-97	23AS05H18	G4-85	23AS25LR56	G4-85	23AZ10L56	G4-82	...	G4-108
23A05H56	G4-48	23A15HA56	G4-48,	23AS05H56	G4-85	23AS25R14	G4-85	23AZ10LR14	G4-82	23DOWN26	G4-104
23A05HA14	G4-48,	...	G4-97	23AS05HA14	G4-85	23AS25R56	G4-85	23AZ10LR18	G4-82	23OPENCOVER	...
...	G4-97	23A15L14	G4-48	23AS05HA18	G4-85	23AS30H14	G4-85	23AZ10R56	G4-82	...	G4-108
23A05HA18	G4-48,	23A15L56	G4-48	23AS05HA56	G4-85	23AS30H56	G4-85	23AZ10R14	G4-82	23PLUGIN	G4-103
...	G4-97	23A15LR14	G4-48	23AS05L14	G4-85	23AS30HA14	G4-85	23AZ10R18	G4-82	23Q05H14	G4-44
23A05HA56	G4-48,	23A15LR56	G4-48	23AS05L18	G4-85	23AS30HA56	G4-85	23AZ10R56	G4-82	23Q05H18	G4-44
...	G4-97	23A15R14	G4-48	23AS05L56	G4-85	23AS30L14	G4-85	23AZ15H14	G4-82	23Q05H56	G4-44
23A05L14	G4-48	23A15R56	G4-48	23AS05LR14	G4-85	23AS30L56	G4-85	23AZ15H56	G4-82	23Q05HA14	G4-44,
23A05L18	G4-48	23A20H14	G4-48	23AS05LR18	G4-85	23AS30LR14	G4-85	23AZ15HA14	G4-82	...	G4-97
23A05L56	G4-48	23A20H56	G4-48	23AS05LR56	G4-85	23AS30LR56	G4-85	23AZ15HA56	G4-82	23Q05HA18	G4-44,
23A05LR14	G4-48	23A20HA14	G4-48,	23AS05R14	G4-85	23AS30R14	G4-85	23AZ15L14	G4-82	...	G4-97
23A05LR18	G4-48	...	G4-97	23AS05R18	G4-85	23AS30R56	G4-85	23AZ15L56	G4-82	23Q05HA56	G4-44,
23A05LR56	G4-48	23A20HA56	G4-48,	23AS05R56	G4-85	23AS40H14	G4-85	23AZ15LR14	G4-82	...	G4-97
23A05R14	G4-48	...	G4-97	23AS07H14	G4-85	23AS40H56	G4-85	23AZ15R56	G4-82	23Q05L14	G4-44
23A05R18	G4-48	23A20L14	G4-48	23AS07H18	G4-85	23AS40HA14	G4-85	23AZ15R14	G4-82	23Q05L18	G4-44
23A05R56	G4-48	23A20L56	G4-48	23AS07H56	G4-85	23AS40HA56	G4-85	23AZ15R56	G4-82	23Q05L56	G4-44
23A07H14	G4-48	23A20LR14	G4-48	23AS07HA14	G4-85	23AS40L14	G4-85	23AZ20H14	G4-82	23Q05LR14	G4-44
23A07H18	G4-48	23A20LR56	G4-48	23AS07HA18	G4-85	23AS40L56	G4-85	23AZ20H56	G4-82	23Q05LR18	G4-44
23A07H56	G4-48	23A20R14	G4-48	23AS07HA56	G4-85	23AS40LR14	G4-85	23AZ20HA14	G4-82	23Q05LR56	G4-44
23A07HA14	G4-48,	23A20R56	G4-48	23AS07L14	G4-85	23AS40LR56	G4-85	23AZ20HA56	G4-82	23Q05R14	G4-44
...	G4-97	23A25H14	G4-48	23AS07L18	G4-85	23AS40R14	G4-85	23AZ20L14	G4-82	23Q05R18	G4-44
23A07HA18	G4-48,	23A25H56	G4-48	23AS07L56	G4-85	23AS40R56	G4-85	23AZ20L56	G4-82	23Q05R56	G4-44
...	G4-97	23A25HA14	G4-48,	23AS07LR14	G4-85	23AS50H56	G4-85	23AZ20LR14	G4-82	23Q07H14	G4-44
23A07HA56	G4-48,	...	G4-97	23AS07LR18	G4-85	23AS50HA56	G4-85	23AZ20LR56	G4-82	23Q07H18	G4-44
...	G4-97	23A25HA56	G4-48,	23AS07LR56	G4-85	23AS50L56	G4-85	23AZ20R14	G4-82	23Q07H56	G4-44
23A07L14	G4-48	...	G4-97	23AS07R14	G4-85	23AS50R56	G4-85	23AZ20R56	G4-82	23Q07HA14	G4-44,
23A07L18	G4-48	23A25L14	G4-48	23AS07R18	G4-85	23AS60H56	G4-85	23AZ25H14	G4-82	...	G4-97
23A07L56	G4-48	23A25L56	G4-48	23AS07R56	G4-85	23AS60HA56	G4-85	23AZ25H56	G4-82	23Q07HA18	G4-44,
23A07LR14	G4-48	23A25LR14	G4-48	23AS10H14	G4-85	23AS60L56	G4-85	23AZ25HA14	G4-82	...	G4-97
23A07LR18	G4-48	23A25LR56	G4-48	23AS10H18	G4-85	23AS60LR56	G4-85	23AZ25HA56	G4-82	23Q07HA56	G4-44,
23A07LR56	G4-48	23A25R14	G4-48	23AS10H56	G4-85	23AS60R56	G4-85	23AZ25L14	G4-82	...	G4-97
23A07R14	G4-48	23A25R56	G4-48	23AS10HA14	G4-85	23AS60R56	G4-85	23AZ25L56	G4-82	23Q07L14	G4-44
23A07R18	G4-48	23A30H14	G4-48	23AS10HA18	G4-85	23AZ05H14	G4-82	23AZ25LR14	G4-82	23Q07L18	G4-44
23A07R56	G4-48	23A30H56	G4-48	23AS10HA56	G4-85	23AZ05H18	G4-82	23AZ25LR56	G4-82	23Q07L56	G4-44
23A10H14	G4-48	23A30HA14	G4-48,	23AS10L14	G4-85	23AZ05H56	G4-82	23AZ25R14	G4-82	23Q07LR14	G4-44
23A10H18	G4-48	...	G4-97	23AS10L18	G4-85	23AZ05HA14	G4-82	23AZ25R56	G4-82	23Q07LR18	G4-44
23A10H56	G4-48	23A30HA56	G4-48,	23AS10L56	G4-85	23AZ05HA18	G4-82	23AZ30H14	G4-82	23Q07LR56	G4-44
23A10HA14	G4-48,	...	G4-97	23AS10LR14	G4-85	23AZ05HA56	G4-82	23AZ30H14	G4-82	23Q07R14	G4-44
...	G4-97	23A30L14	G4-48	23AS10LR18	G4-85	23AZ05L14	G4-82	23AZ30HA14	G4-82	23Q07R18	G4-44
23A10HA18	G4-48,	23A30L56	G4-48	23AS10LR56	G4-85	23AZ05L18	G4-82	23AZ30HA56	G4-82	23Q07R56	G4-44
...	G4-97	23A30LR14	G4-48	23AS10R14	G4-85	23AZ05L56	G4-82	23AZ30L14	G4-82	23Q10H14	G4-44
23A10HA56	G4-48,	23A30LR56	G4-48	23AS10R18	G4-85	23AZ05LR14	G4-82	23AZ30L56	G4-82	23Q10H18	G4-44
...	G4-97	23A30R14	G4-48	23AS10R56	G4-85	23AZ05LR18	G4-82	23AZ30LR14	G4-82	23Q10H56	G4-44
23A10L14	G4-48	23A30R56	G4-48	23AS15H14	G4-85	23AZ05LR56	G4-82	23AZ30LR56	G4-82	23Q10HA14	G4-44,
23A10L18	G4-48	23A40H14	G4-48	23AS15H18	G4-85	23AZ05R14	G4-82	23AZ30R14	G4-82	...	G4-97
23A10L56	G4-48	23A40H56	G4-48	23AS15HA14	G4-85	23AZ05R18	G4-82	23AZ30R56	G4-82	23Q10HA18	G4-97
23A10LR14	G4-48	23A40HA14	G4-48,	23AS15HA56	G4-85	23AZ05R56	G4-82	23AZ40H14	G4-82	23Q10HA56	G4-44,
...	G4-97	...	G4-97	23AS15L14	G4-85	23AZ07H14	G4-82	23AZ40H56	G4-82	...	G4-97
23A10LR18	G4-48	23A40HA56	G4-48,	23AS15L56	G4-85	23AZ07H18	G4-82	23AZ40HA14	G4-82	23Q10L14	G4-44
23A10LR56	G4-48	...	G4-97	23AS15LR14	G4-85	23AZ07H56	G4-82	23AZ40HA56	G4-82	23Q10L18	G4-44
23A10R14	G4-48	23A40L14	G4-48	23AS15LR56	G4-85	23AZ07HA14	G4-82	23AZ40L14	G4-82	23Q10L56	G4-44
23A10R18	G4-48	23A40L56	G4-48	23AS15R14	G4-85	23AZ07HA18	G4-82	23AZ40L56	G4-82	23Q10LR14	G4-44
23A10R56	G4-48	23A40LR14	G4-48	23AS15R56	G4-85	23AZ07HA56	G4-82	23AZ40LR14	G4-82	23Q10LR18	G4-44
23A12H14	G4-48	23A40LR56	G4-48	23AS20H14	G4-85	23AZ07L14	G4-82	23AZ40LR56	G4-82	23Q10LR56	G4-44
23A12H18	G4-48	23A40R14	G4-48	23AS20H56	G4-85	23AZ07L18	G4-82	23AZ40R14	G4-82	23Q10R14	G4-44
23A12H56	G4-48	23A40R56	G4-48	23AS20HA14	G4-85	23AZ07L56	G4-82	23AZ40R56	G4-82	23Q10R18	G4-44
23A12HA14	G4-48	23A50H56	G4-48	23AS20HA56	G4-85	23AZ07LR14	G4-82	23AZ50H56	G4-82	23Q10R56	G4-44
23A12HA18	G4-48	...	G4-97	23AS20L14	G4-85	23AZ07LR18	G4-82	23AZ50HA56	G4-82	23Q12H14	G4-44
23A12HA56	G4-48	...	G4-97	...	G4-97	...	G4-97	G4-97	

PART NUMBER INDEX



Part No.	Page	Part No.	Page	Part No.	Page	Part No.	Page	Part No.	Page	Part No.	Page
23Q12H18	G4-44	23Q30L56	G4-44	23QS10H18	G4-84	23QS60L56	G4-84	23QZ25HA14	G4-80	23S20L	G4-46
23Q12H56	G4-44		G4-86	23QS10H56	G4-84	23QS60LR56		23QZ25HA56	G4-80	23S20LR	G4-46
23Q12HA14	G4-44	23Q30LR14	G4-44	23QS10HA14	G4-84		G4-84	23QZ25L14	G4-80	23S20R	G4-46
23Q12HA18	G4-44	23Q30LR56	G4-44	23QS10HA18	G4-84	23QS60R56	G4-84	23QZ25L56	G4-80	23S25H	G4-46
23Q12HA56	G4-44		G4-86	23QS10HA56	G4-84	23QZ05H14	G4-80	23QZ25LR14	G4-80	23S25HA	G4-46
23Q12L14	G4-44	23Q30R14	G4-44	23QS10L14	G4-84	23QZ05H18	G4-80	23QZ25LR56	G4-80		G4-97
23Q12L18	G4-44	23Q30R56	G4-44	23QS10L18	G4-84	23QZ05H56	G4-80	23QZ25R14	G4-80	23S25L	G4-46
23Q12L56	G4-44		G4-86	23QS10L56	G4-84	23QZ05HA14	G4-80	23QZ25R56	G4-80	23S25LR	G4-46
23Q12LR14	G4-44	23Q40H14	G4-44	23QS10LR14	G4-84	23QZ05HA18	G4-80	23QZ30H14	G4-80	23S25R	G4-46
23Q12LR18	G4-44	23Q40H56	G4-44	23QS10LR18	G4-84	23QZ05HA56	G4-80	23QZ30H56	G4-80	23S30H	G4-46
23Q12LR56	G4-44		G4-86	23QS10LR56	G4-84	23QZ05L14	G4-80	23QZ30HA14	G4-80	23S30HA	G4-46
23Q12R14	G4-44	23Q40HA14	G4-44	23QS10R14	G4-84	23QZ05L18	G4-80	23QZ30HA56	G4-80	23S30H	G4-97
23Q12R18	G4-44		G4-97	23QS10R18	G4-84	23QZ05L56	G4-80	23QZ30L14	G4-80	23S30L	G4-46
23Q12R56	G4-44	23Q40HA56	G4-44	23QS10R56	G4-84	23QZ05LR14	G4-80	23QZ30L56	G4-80	23S30LR	G4-46
23Q15H14	G4-44		G4-97	23QS15H14	G4-84	23QZ05LR18	G4-80	23QZ30LR14	G4-80	23S30R	G4-46
23Q15H56	G4-44	23Q40L14	G4-44	23QS15H56	G4-84	23QZ05LR56	G4-80	23QZ30LR56	G4-80	23S40H	G4-46
	G4-86	23Q40L56	G4-44	23QS15HA14	G4-84	23QZ05R14	G4-80	23QZ30R14	G4-80	23S40HA	G4-46
23Q15HA14	G4-44		G4-86	23QS15HA56	G4-84	23QZ05R18	G4-80	23QZ30R56	G4-80		G4-97
	G4-97	23Q40LR14	G4-44	23QS15L14	G4-84	23QZ05R56	G4-80	23QZ40H14	G4-80	23S40L	G4-46
23Q15HA56	G4-44	23Q40LR56	G4-44	23QS15L56	G4-84	23QZ05R56	G4-80	23QZ40H56	G4-80	23S40LR	G4-46
	G4-97		G4-86	23QS15LR14	G4-84	23QZ07H18	G4-80	23QZ40HA14	G4-80	23S40R	G4-46
23Q15L14	G4-44	23Q40R14	G4-44	23QS15LR56	G4-84	23QZ07H56	G4-80	23QZ40HA56	G4-80	23S50H	G4-46
23Q15L56	G4-44	23Q40R56	G4-44	23QS15R14	G4-84	23QZ07HA14	G4-80	23QZ40L14	G4-80	23S50HA	G4-46
	G4-86		G4-86	23QS15R56	G4-84	23QZ07HA18	G4-80	23QZ40L56	G4-80		G4-97
23Q15LR14	G4-44	23Q50H56	G4-44	23QS20H14	G4-84	23QZ07HA56	G4-80	23QZ40LR14	G4-80	23S50L	G4-46
23Q15LR56	G4-44	23Q50HA56	G4-44	23QS20H56	G4-84	23QZ07L14	G4-80	23QZ40LR56	G4-80	23S50LR	G4-46
	G4-86		G4-97	23QS20HA14	G4-84	23QZ07L18	G4-80	23QZ40R14	G4-80	23S50R	G4-46
23Q15R14	G4-44	23Q50L56	G4-44	23QS20HA56	G4-84	23QZ07L56	G4-80	23QZ40R56	G4-80	23S60H	G4-46
23Q15R56	G4-44	23Q50LR56	G4-44	23QS20L14	G4-84	23QZ07L18	G4-80	23QZ50H56	G4-80	23S60HA	G4-46
	G4-86	23Q50R56	G4-44	23QS20L56	G4-84	23QZ07LR18	G4-80	23QZ50HA56	G4-80		G4-97
23Q20H14	G4-44	23Q60H56	G4-44	23QS20LR14	G4-84	23QZ07LR56	G4-80	23QZ50L56	G4-80	23S60L	G4-46
23Q20H56	G4-44		G4-86	23QS20LR56	G4-84	23QZ07R14	G4-80	23QZ50LR56	G4-80	23S60LR	G4-46
	G4-86	23Q60HA56	G4-44	23QS20R14	G4-84	23QZ07R18	G4-80	23QZ50R56	G4-80	23S60R	G4-46
23Q20HA14	G4-44		G4-97	23QS20R56	G4-84	23QZ07R56	G4-80	23QZ60H56	G4-80	23SBASE	G4-91
	G4-97	23Q60L56	G4-44	23QS25H14	G4-84	23QZ10H14	G4-80	23QZ60HA56	G4-80	23SFLANGE	G4-95
23Q20HA56	G4-44		G4-86	23QS25H56	G4-84	23QZ10H18	G4-80	23QZ60H56	G4-80	23SHAFTREV	
	G4-97	23Q60LR56	G4-44	23QS25HA14	G4-84	23QZ10H56	G4-80	23QZ60LR56	G4-80		G4-107
23Q20L14	G4-44		G4-86	23QS25HA56	G4-84	23QZ10HA14	G4-80	23QZ60R56	G4-80	23STBUSH100	
23Q20L56	G4-44	23Q60R56	G4-44	23QS25L14	G4-84	23QZ10HA18	G4-80	23RISER	G4-93		G4-96
	G4-86		G4-86	23QS25L56	G4-84	23QZ10HA56	G4-80	23S05H	G4-46	23STBUSH103	
23Q20LR14	G4-44	23QS05H14	G4-84	23QS25LR14	G4-84	23QZ10L14	G4-80		G4-46		G4-96
23Q20LR56	G4-44	23QS05H18	G4-84	23QS25LR56	G4-84	23QZ10L18	G4-80		G4-97	23TBUSH100	G4-96
	G4-86	23QS05H56	G4-84	23QS25R14	G4-84	23QZ10L56	G4-80	23S05L	G4-46	23TBUSH103	G4-96
23Q20R14	G4-44	23QS05HA14	G4-84	23QS25R56	G4-84	23QZ10LR14	G4-80	23S05LR	G4-46	23ZBASE	G4-91
23Q20R56	G4-44	23QS05HA18	G4-84	23QS30H14	G4-84	23QZ10LR18	G4-80	23S05R	G4-46	23ZRISER	G4-93
	G4-86	23QS05HA56	G4-84	23QS30H56	G4-84	23QZ10LR56	G4-80	23S07H	G4-46	240050	G1-123
23Q25H14	G4-44	23QS05L14	G4-84	23QS30HA14	G4-84	23QZ10R14	G4-80	23S07HA	G4-46		G2-157
23Q25H56	G4-44	23QS05L18	G4-84	23QS30HA56	G4-84	23QZ10R18	G4-80		G4-97	240051	G1-123
	G4-86	23QS05L56	G4-84	23QS30L14	G4-84	23QZ10R56	G4-80	23S07L	G4-46		G2-157
23Q25HA14	G4-44	23QS05LR14	G4-84	23QS30L56	G4-84	23QZ15H14	G4-80	23S07LR	G4-46	241065	G2-29
	G4-97	23QS05LR18	G4-84	23QS30LR14	G4-84	23QZ15H56	G4-80	23S07R	G4-46	241066	G2-29
23Q25HA56	G4-44	23QS05LR56	G4-84	23QS30LR56	G4-84	23QZ15HA14	G4-80	23S10H	G4-46	241069	G2-144
	G4-97	23QS05R14	G4-84	23QS30R14	G4-84	23QZ15HA56	G4-80	23S10HA	G4-46	241070	G2-144
23Q25L14	G4-44	23QS05R18	G4-84	23QS30R56	G4-84	23QZ15L14	G4-80		G4-97	241073	G2-29
23Q25L56	G4-44	23QS05R56	G4-84	23QS40H14	G4-84	23QZ15L56	G4-80	23S10L	G4-46	241074	G2-29
	G4-86	23QS07H14	G4-84	23QS40H56	G4-84	23QZ15LR14	G4-80	23S10LR	G4-46	241077	G2-146
23Q25LR14	G4-44	23QS07H18	G4-84	23QS40HA14	G4-84	23QZ15LR56	G4-80	23S10R	G4-46	241078	G2-146
23Q25LR56	G4-44	23QS07H56	G4-84	23QS40HA56	G4-84	23QZ15R14	G4-80	23S12H	G4-46	241083	G2-31
	G4-86	23QS07HA14	G4-84	23QS40A56	G4-84	23QZ15R56	G4-80	23S12HA	G4-46	241085	G2-145
23Q25R14	G4-44	23QS07HA18	G4-84	23QS40L14	G4-84	23QZ20H14	G4-80	23S12H	G4-46	241087	G2-31
23Q25R56	G4-44	23QS07HA56	G4-84	23QS40L56	G4-84	23QZ20H56	G4-80	23S12LR	G4-46	241089	G2-147
	G4-86	23QS07L14	G4-84	23QS40LR14	G4-84	23QZ20HA14	G4-80	23S12R	G4-46	241092	G2-29
23Q30H14	G4-44	23QS07L18	G4-84	23QS40LR56	G4-84	23QZ20HA56	G4-80	23S15H	G4-46	241101	G2-211
23Q30H56	G4-44	23QS07LR14	G4-84	23QS40R14	G4-84	23QZ20HA56	G4-80	23S15HA	G4-46	241102	G2-157
	G4-86	23QS07LR18	G4-84	23QS40R56	G4-84	23QZ20L14	G4-80		G4-97	241103	G1-123
23Q30HA14	G4-44	23QS07LR18	G4-84	23QS50H56	G4-84	23QZ20L56	G4-80	23S15L	G4-46		G2-157
	G4-97	23QS07LR56	G4-84	23QS50HA56	G4-84	23QZ20LR14	G4-80	23S15LR	G4-46	241104	G1-123
23Q30HA56	G4-44	23QS07R14	G4-84	23QS50L56	G4-84	23QZ20LR56	G4-80	23S15R	G4-46		G2-157
	G4-97	23QS07R18	G4-84	23QS50LR56	G4-84	23QZ20R14	G4-80	23S20H	G4-46	241105	G2-157
23Q30L14	G4-44	23QS07R56	G4-84	23QS50R56	G4-84	23QZ20R56	G4-80	23S20HA	G4-46	241109	G2-157
		23QS10H14	G4-84	23QS60H56	G4-84	23QZ25H14	G4-80		G4-97		
		23QS60HA56	G4-84	23QS60H56	G4-84	23QZ25H56	G4-80				

PART NUMBER INDEX



Part No.	Page	Part No.	Page	Part No.	Page	Part No.	Page	Part No.	Page	Part No.	Page
241142	G2-93, G2-124	242152	G2-33, G2-35, G2-159	243106	G2-37, G2-78, G2-211	243427	G2-37, G2-39	244148	G2-43, G2-78, G2-211	244553	G2-148
241149	G2-91, G2-124	242154	G2-33, G2-35, G2-159	243108	G2-157	243428	G2-37, G2-39	244151	G2-41, G2-77	244554	G2-148
241153	G2-159	242156	G2-33, G2-35, G2-159	243109	G2-157	243429	G2-37, G2-39	244152	G2-103, G2-124	244555	G2-152
241154	G2-159	242158	G2-33, G2-35, G2-159	243115	G5-50	243442	G2-37, G2-39	244159	G2-157	244557	G2-152
241155	G2-159	242162	G2-33, G2-35, G2-159	243153	G2-37, G2-77	243446	G2-121	244164	G2-43, G2-77	244594	G2-102, G2-104, G2-148, G2-150
241213	G2-159	242164	G2-33, G2-35, G2-159	243154	G2-99, G2-124	243447	G2-121	244167	G2-105, G2-124	244595	G2-102, G2-104, G2-148, G2-150
241278	G2-29, G2-31, G2-159	242166	G2-33, G2-35, G2-159	243164	G2-39, G2-77	243448	G2-121	244251	G2-159	244598	G2-102, G2-104, G2-148, G2-150
241280	G2-159	242168	G2-33, G2-35, G2-159	243167	G2-101, G2-124	243449	G2-121	244252	G2-159	244599	G2-102, G2-104, G2-148, G2-150
241282	G2-29, G2-31, G2-159	242223	G2-33, G2-35, G2-159	243251	G2-159	243500	G2-37	244253	G2-159	244597	G2-102, G2-104, G2-148, G2-150
241286	G2-29, G2-31, G2-159	242225	G2-33, G2-35, G2-159	243252	G2-159	243501	G2-37	244254	G2-159	244598	G2-102, G2-104, G2-148, G2-150
241288	G2-29, G2-31, G2-159	242226	G2-33, G2-35, G2-159	243253	G2-159	243502	G2-37	244340	G2-196	244676	G2-41, G2-79, G2-157
241290	G2-29, G2-31, G2-159	242227	G2-33, G2-35, G2-159	243254	G2-159	243507	G2-144	244382	G2-200	244677	G2-103, G2-125, G2-157
241292	G2-29, G2-31, G2-159	242228	G2-124	243260	G2-37, G2-39, G2-159	243510	G2-144	244383	G2-200	244680	G2-121
241294	G2-29, G2-31, G2-159	242229	G2-145	243262	G2-37, G2-39, G2-159	243511	G2-146	244384	G2-200	244681	G2-121
241327	G2-29	242251	G2-35	243264	G2-37, G2-39, G2-159	243512	G2-146	244385	G2-200	244682	G2-121
241340	G2-196	242253	G2-147	243266	G2-37, G2-39, G2-159	243524	G2-98	244386	G2-200	244683	G2-121
241342	G2-29	242255	G2-147	243272	G2-37, G2-39, G2-159	243525	G2-98	244391	G2-41, G2-43, G2-72	244684	G2-121
241344	G2-29	242257	G2-159	243270	G2-37, G2-39, G2-159	243526	G2-98	244392	G2-41, G2-43, G2-74	244688	G2-157
241345	G2-29	242258	G2-159	243274	G2-37, G2-39, G2-159	243528	G2-148	244395	G2-41, G2-76	244689	G2-157
241346	G2-29	242259	G2-159	243276	G2-37, G2-39, G2-159	243529	G2-148	244397	G2-41, G2-76	244698	G2-157
241347	G2-29	242280	G2-159	243277	G2-37, G2-39, G2-159	243552	G2-100, G2-148, G2-150	244404	G2-41, G2-43, G2-75	245015	G2-109, G2-124
241383	G5-50	242327	G2-33	243278	G2-37, G2-39, G2-159	243553	G2-100, G2-148, G2-150	244420	G2-41, G2-43	245086	G2-45, G2-47, G2-159
241391	G2-29, G2-31, G2-33, G2-35, G2-72	242344	G2-33, G2-35	243279	G2-37, G2-39, G2-159	243556	G2-100, G2-148, G2-150	244421	G2-41, G2-43	245090	G2-45, G2-47, G2-159
241395	G2-29, G2-76	242345	G2-33, G2-35	243282	G2-37, G2-39, G2-159	243571	G2-152	244422	G2-41, G2-43	245092	G2-45, G2-47, G2-159
241397	G2-31, G2-76	242346	G2-33, G2-35	243284	G2-37, G2-39, G2-159	243577	G2-37, G2-79, G2-157	244423	G2-41, G2-43	245099	G2-45, G2-47, G2-159
241415	G2-200	242347	G2-33, G2-35	243288	G2-37, G2-39, G2-159	243581	G2-37, G2-80, G2-99	244424	G2-41, G2-43	245101	G2-211
241416	G2-200	242348	G2-33, G2-35	243289	G2-37, G2-39, G2-159	243582	G2-99, G2-125, G2-157	244426	G2-41, G2-43	245102	G2-45, G2-77
241417	G2-200	242349	G2-33, G2-35	243294	G2-37, G2-76	243620	G2-200	244427	G2-41, G2-43	245103	G2-107, G2-124
241418	G2-200	242348	G2-33, G2-35	243297	G2-37, G2-76	243621	G2-200	244428	G2-41, G2-43	245106	G2-157
241419	G2-200	242349	G2-33, G2-35	243298	G2-37, G2-76	243622	G2-200	244429	G2-41, G2-43	245110	G2-45, G2-47, G2-159
241420	G2-200	242350	G2-33, G2-35	243299	G2-37, G2-76	243623	G2-200	244430	G2-41, G2-43	245112	G2-45, G2-47, G2-159
241421	G2-29, G2-31, G2-75	242351	G2-33, G2-35	243301	G2-37, G2-39, G2-72	243624	G2-200	244431	G2-41, G2-43	245154	G2-45, G2-78, G2-211
241480	G2-90	242392	G5-50	243302	G2-37, G2-39, G2-74	243625	G2-200	244432	G2-41, G2-43	245162	G2-47, G2-77
241489	G2-91, G2-123	242397	G2-35, G2-76	243303	G2-37, G2-39, G2-74	243626	G2-200	244433	G2-41, G2-43	245251	G2-159
241491	G2-93, G2-123	242415	G2-200	243304	G2-37, G2-39, G2-72	243627	G2-200	244434	G2-103, G2-123	245252	G2-159
242079	G2-33	242416	G2-200	243305	G2-37, G2-39, G2-72	243628	G2-200	244435	G2-105, G2-123	245253	G2-159
242082	G2-33	242417	G2-200	243306	G2-37, G2-39, G2-72	243629	G2-200	244436	G2-105, G2-123	245254	G2-159
242083	G2-33	242418	G2-200	243307	G2-37, G2-39, G2-72	243630	G2-200	244437	G2-105, G2-123	245340	G2-196
242086	G2-144	242419	G2-200	243308	G2-37, G2-39, G2-72	243631	G2-200	244438	G2-105, G2-123	245341	G2-200
242087	G2-144	242420	G2-200	243309	G2-37, G2-39, G2-72	243632	G2-200	244439	G2-105, G2-123	245342	G2-200
242090	G2-33	242421	G2-33, G2-35, G2-75	243310	G2-37, G2-39, G2-72	243633	G2-200	244440	G2-105, G2-123	245343	G2-200
242091	G2-33	242422	G2-33, G2-35, G2-75	243311	G2-37, G2-39, G2-72	243634	G2-200	244441	G2-105, G2-123	245344	G2-200
242094	G2-146	242423	G2-33, G2-35, G2-75	243312	G2-37, G2-39, G2-72	243635	G2-200	244442	G2-105, G2-123	245345	G2-200
242095	G2-146	242424	G2-33, G2-35, G2-75	243313	G2-37, G2-39, G2-72	243636	G2-200	244443	G2-105, G2-123	245346	G2-200
242101	G2-29, G2-31, G2-78, G2-211	242425	G2-33, G2-35, G2-75	243314	G2-37, G2-39, G2-72	243637	G2-200	244444	G2-105, G2-123	245347	G2-200
242102	G2-157	242426	G2-33, G2-35, G2-75	243315	G2-37, G2-39, G2-72	243638	G2-200	244445	G2-105, G2-123	245348	G2-200
242109	G2-157	242427	G2-33, G2-35, G2-75	243316	G2-37, G2-39, G2-72	243639	G2-200	244446	G2-105, G2-123	245349	G2-200
242114	G2-97, G2-124	242428	G2-94, G2-95, G2-123	243317	G2-37, G2-39, G2-72	243640	G2-200	244447	G2-105, G2-123	245350	G2-200
242146	G2-33, G2-35, G2-159	242429	G2-95, G2-97, G2-123	243318	G2-37, G2-39, G2-72	243641	G2-200	244448	G2-105, G2-123	245351	G2-200
242148	G2-33, G2-35, G2-159	242430	G2-95, G2-97, G2-123	243319	G2-37, G2-39, G2-72	243642	G2-200	244449	G2-105, G2-123	245352	G2-200
242150	G2-33, G2-35, G2-159	242431	G2-95, G2-97, G2-123	243320	G2-37, G2-39, G2-72	243643	G2-200	244450	G2-105, G2-123	245353	G2-200
		242432	G2-95, G2-97, G2-123	243321	G2-37, G2-39, G2-72	243644	G2-200	244451	G2-105, G2-123	245354	G2-200
		242433	G2-95, G2-97, G2-123	243322	G2-37, G2-39, G2-72	243645	G2-200	244452	G2-105, G2-123	245355	G2-200
		242434	G2-95, G2-97, G2-123	243323	G2-37, G2-39, G2-72	243646	G2-200	244453	G2-105, G2-123	245356	G2-200
		242435	G2-95, G2-97, G2-123	243324	G2-37, G2-39, G2-72	243647	G2-200	244454	G2-105, G2-123	245357	G2-200
		242436	G2-95, G2-97, G2-123	243325	G2-37, G2-39, G2-72	243648	G2-200	244455	G2-105, G2-123	245358	G2-200
		242437	G2-95, G2-97, G2-123	243326	G2-37, G2-39, G2-72	243649	G2-200	244456	G2-105, G2-123	245359	G2-200
		242438	G2-95, G2-97, G2-123	243327	G2-37, G2-39, G2-72	243650	G2-200	244457	G2-105, G2-123	245360	G2-200
		242439	G2-95, G2-97, G2-123	243328	G2-37, G2-39, G2-72	243651	G2-200	244458	G2-105, G2-123	245361	G2-200
		242440	G2-95, G2-97, G2-123	243329	G2-37, G2-39, G2-72	243652	G2-200	244459	G2-105, G2-123	245362	G2-200
		242441	G2-95, G2-97, G2-123	243330	G2-37, G2-39, G2-72	243653	G2-200	244460	G2-105, G2-123	245363	G2-200
		242442	G2-95, G2-97, G2-123	243331	G2-37, G2-39, G2-72	243654	G2-200	244461	G2-105, G2-123	245364	G2-200
		242443	G2-95, G2-97, G2-123	243332	G2-37, G2-39, G2-72	243655	G2-200	244462	G2-105, G2-123	245365	G2-200
		242444	G2-95, G2-97, G2-123	243333	G2-37, G2-39, G2-72	243656	G2-200	244463	G2-105, G2-123	245366	G2-200
		242445	G2-95, G2-97, G2-123	243334	G2-37, G2-39, G2-72	243657	G2-200	244464	G2-105, G2-123	245367	G2-200
		242446	G2-95, G2-97, G2-123	243335	G2-37, G2-39, G2-72	243658	G2-200	244465	G2-105, G2-123	245368	G2-200
		242447	G2-95, G2-97, G2-123	243336	G2-37, G2-39, G2-72	243659	G2-200	244466	G2-105, G2-123	245369	G2-200
		242448	G2-95, G2-97, G2-123	243337	G2-37, G2-39, G2-72	243660	G2-200</				

PART NUMBER INDEX



Part No.	Page	Part No.	Page	Part No.	Page	Part No.	Page	Part No.	Page	Part No.	Page
245391	G2-45	246149	G2-49	246520	G2-152	247396	G2-53	248484	G2-119	252146	G2-97
	G2-47,G2-72	246150	G2-49	246543	G2-157		G2-55,G2-74		G2-125		G2-125
245392	G2-45	246151	G2-49	246601	G2-157	247404	G2-53	248488	G2-157	252198	G2-157
	G2-47,G2-74	246154	G2-144	246602	G2-157		G2-55,G2-75	249102	G2-157	253140	G2-152
245393	G2-45	246155	G2-144	246603	G2-157	247420	G2-53	249260	G2-57	253146	G2-101
	G2-47,G2-72	246158	G2-49	246604	G2-157		G2-55		G2-61		G2-125
245405	G2-45	246159	G2-49	246605	G2-157	247422	G2-53		G2-78,G2-212	253151	G2-39
	G2-47,G2-75	246162	G2-146	246606	G2-157		G2-55	249265	G2-63	253153	G2-145
245422	G2-45	246163	G2-146	246607	G2-157	247425	G2-53	249267	G2-63	253155	G2-39
	G2-47	246261	G2-49	246608	G2-157		G2-55	249269	G2-61	253157	G2-147
245423	G2-45		G2-51	246609	G2-157	247426	G2-53	249270	G2-61	253159	G2-100
	G2-47	246262	G2-49	246610	G2-157		G2-55	249273	G2-61	253160	G2-150
245424	G2-45		G2-51	246611	G2-157	247427	G2-53	249274	G2-61	253186	G2-39
	G2-47	246263	G2-49	246612	G2-157		G2-55	249340	G2-196		G2-79,G2-157
245425	G2-45		G2-51	246613	G2-157	247428	G2-53	249395	G2-61	253188	G2-39
	G2-47	246264	G2-49	246614	G2-157		G2-55		G2-76		G2-80,G2-101
245426	G2-45		G2-51	246615	G2-157	247431	G2-200	249397	G2-63	253199	G2-159
	G2-47	246265	G2-49	246616	G2-157	247432	G2-200		G2-76	254101	G2-212
245427	G2-45		G2-51	246617	G2-157	247433	G2-200	249399	G2-61	254140	G2-152
	G2-47	246266	G2-49	246618	G2-157	247434	G2-200		G2-63,G2-73	254146	G2-105
245428	G2-45		G2-51	246619	G2-157	247435	G2-200	249401	G2-61		G2-125
	G2-47	246267	G2-49	246620	G2-157	247436	G2-200		G2-63,G2-73	254199	G2-159
245444	G2-157		G2-51	246621	G2-157	247444	G2-157	249404	G2-61	254200	G2-43
245474	G2-121	246268	G2-49	246622	G2-157	247474	G2-115		G2-63,G2-75	254202	G2-145
245476	G2-121		G2-51	246623	G2-157		G2-123	249414	G2-200	254204	G2-43
245477	G2-121	246283	G2-49	246624	G2-157	247476	G2-117	249415	G2-200	254206	G2-147
245478	G2-121		G2-51	246625	G2-157		G2-123	249416	G2-200	254208	G2-104
245495	G2-107	246327	G2-49	246627	G2-157	247480	G2-114	249417	G2-200	254209	G2-150
	G2-123	246340	G2-196	246628	G2-157	247520	G2-152	249418	G2-200	254267	G2-43
245497	G2-109	246366	G2-49	246629	G2-157	247698	G2-157	249419	G2-200		G2-79,G2-157
	G2-123		G2-76	246630	G2-157	248101	G2-212	249420	G2-61	254268	G2-43
245543	G2-157	246368	G2-51	246631	G2-157	248102	G2-157		G2-63		G2-80,G2-105
245550	G2-45		G2-76	246632	G2-157	248275	G2-59	249421	G2-61	255101	G2-212
245551	G2-45	246380	G2-51	246633	G2-157	248277	G2-59		G2-63	255148	G2-109
245552	G2-45	246382	G2-51	246634	G2-157	248279	G2-57	249422	G2-61		G2-125,G2-157
245557	G2-144	246388	G2-49	246635	G2-157	248280	G2-57		G2-63	255160	G2-152
245558	G2-144	246390	G2-49	246698	G2-157	248283	G2-57	249444	G2-157	255199	G2-159
245562	G2-45		G2-51,G2-74	247092	G2-212	248284	G2-57	249488	G2-157	255200	G2-47
245563	G2-45	246391	G2-49	247101	G2-212	248340	G2-196	250101	G2-212	255202	G2-145
245564	G2-45		G2-51,G2-72	247102	G2-157	248395	G2-57	250102	G2-157	255204	G2-47
245569	G2-146	246392	G2-49	247146	G2-55		G2-76	250260	G2-59	255206	G2-147
245570	G2-146		G2-51		G2-77	248397	G2-59		G2-65	255208	G2-108
245574	G2-106		G2-75	247149	G2-117		G2-76		G2-66	255209	G2-150
245575	G2-106	246420	G2-49		G2-124	248401	G2-57		G2-78,G2-212	255230	G2-47
245576	G2-106		G2-51	247152	G2-53		G2-59,G2-73	250395	G2-65		G2-79,G2-157
245578	G2-148	246421	G2-49		G2-77	248406	G2-57		G2-76	255231	G2-47
245579	G2-148		G2-51	247153	G2-115		G2-59,G2-75	250401	G2-65		G2-80
245635	G2-45	246422	G2-49		G2-124	248414	G2-200		G2-73	256101	G2-212
	G2-79,G2-157		G2-51	247159	G2-53	248415	G2-200	250404	G2-65	257101	G2-212
245637	G2-107	246423	G2-49	247160	G2-53	248416	G2-200		G2-73	259023	G2-160
	G2-125,G2-157		G2-51	247161	G2-53	248417	G2-200	250411	G2-65	259024	G2-160
245640	G2-152	246424	G2-49	247164	G2-144	248418	G2-200		G2-75	259164	G2-160
245651	G2-121		G2-51	247165	G2-144	248419	G2-200	250416	G2-200	259166	G2-160
245652	G2-121	246425	G2-49	247168	G2-53	248420	G2-57	250417	G2-200	26A05H14	G4-54
245653	G2-121		G2-51	247169	G2-53		G2-59	250418	G2-200	26A05H18	G4-54
245654	G2-121	246426	G2-49	247172	G2-146	248422	G2-57	250419	G2-200	26A05HA14	G4-54
245698	G2-157		G2-51	247173	G2-146		G2-59	250420	G2-65		G4-97
246092	G2-49	246427	G2-49	247260	G2-53	248423	G2-57	250421	G2-65	26A05HA18	G4-54
	G2-51		G2-51		G2-55		G2-59	250422	G2-65		G4-97
	G2-78,G2-211	246428	G2-200		G2-78,G2-212	248424	G2-57	250444	G2-157	26A05L14	G4-54
246101	G2-47	246429	G2-200	247285	G2-55		G2-59	250448	G2-157	26A05L18	G4-54
	G2-78,G2-212	246430	G2-200	247287	G2-55	248443	G2-157	251120	G2-159	26A05LR14	G4-54
246102	G2-157	246431	G2-200	247327	G2-53	248444	G2-157	251140	G2-152	26A05LR18	G4-54
246132	G2-51	246432	G2-200	247345	G2-196	248464	G2-119	251146	G2-93	26A05R14	G4-54
	G2-77	246433	G2-200	247390	G2-53	248465	G2-119		G2-125	26A05R18	G4-54
246142	G2-113	246444	G2-157		G2-76	248469	G2-119	252101	G2-33	26A07H14	G4-54
	G2-124	246476	G2-111	247392	G2-55	248470	G2-119		G2-35	26A07H18	G4-54
246147	G2-49		G2-123		G2-76	248473	G2-119		G2-39	26A07H56	G4-54
	G2-77	246478	G2-113	247395	G2-53	248474	G2-119		G2-78,G2-212	26A07HA14	G4-54
246148	G2-111		G2-123		G2-55,G2-72	248477	G2-119	252120	G2-159		G4-97
	G2-124	246480	G2-110				G2-124	252140	G2-152		

PART NUMBER INDEX



Part No.	Page	Part No.	Page	Part No.	Page	Part No.	Page	Part No.	Page	Part No.	Page
26A07HA18	G4-54,	26A25R14	G4-54	26AZ07LR56	G4-83	26AZ40LR56	G4-83	26Q10L18	G4-50	26Q30L56	G4-50
	G4-97	26A25R56	G4-54	26AZ07R14	G4-83	26AZ40R14	G4-83	26Q10L56	G4-50		G4-86
26A07HA56	G4-54,	26A30H14	G4-54	26AZ07R18	G4-83	26AZ40R56	G4-83	26Q10LR14	G4-50	26Q30LR14	G4-50
	G4-97	26A30H56	G4-54	26AZ07R56	G4-83	26AZ50H14	G4-83	26Q10LR18	G4-50	26Q30LR56	G4-50
26A07L14	G4-54	26A30HA14	G4-54,	26AZ10H14	G4-83	26AZ50H56	G4-83	26Q10LR56	G4-50		G4-86
26A07L18	G4-54		G4-97	26AZ10H18	G4-83	26AZ50HA14	G4-83	26Q10R14	G4-50	26Q30R14	G4-50
26A07L56	G4-54	26A30HA56	G4-54,	26AZ10H56	G4-83	26AZ50HA56	G4-83	26Q10R18	G4-50		G4-50
26A07LR14	G4-54		G4-97	26AZ10HA14	G4-83	26AZ50L14	G4-83	26Q10R56	G4-50		G4-86
26A07LR18	G4-54	26A30L14	G4-54	26AZ10HA18	G4-83	26AZ50L56	G4-83	26Q15H14	G4-50	26Q40H14	G4-50
26A07LR56	G4-54	26A30L56	G4-54	26AZ10HA56	G4-83	26AZ50LR14	G4-83	26Q15H18	G4-50	26Q40H56	G4-50,
26A07R14	G4-54	26A30LR14	G4-54	26AZ10L14	G4-83	26AZ50LR56	G4-83	26Q15H56	G4-50,		G4-86
26A07R18	G4-54	26A30LR56	G4-54	26AZ10L18	G4-83	26AZ50R14	G4-83		G4-86	26Q40HA14	G4-50,
26A07R56	G4-54	26A30R14	G4-54	26AZ10L56	G4-83	26AZ50R56	G4-83	26Q15HA14	G4-50,		G4-97
26A10H14	G4-54	26A30R56	G4-54	26AZ10LR14	G4-83	26AZ60H14	G4-83		G4-97	26Q40HA56	G4-50,
26A10H18	G4-54	26A40H14	G4-54	26AZ10LR18	G4-83	26AZ60H56	G4-83	26Q15HA18	G4-50		G4-97
26A10H56	G4-54	26A40H56	G4-54	26AZ10LR56	G4-83	26AZ60HA14	G4-83		G4-97	26Q40L14	G4-50
26A10HA14	G4-54,	26A40HA14	G4-54,	26AZ10R14	G4-83	26AZ60HA56	G4-83	26Q15HA56	G4-50,	26Q40L56	G4-50,
	G4-97		G4-97	26AZ10R18	G4-83	26AZ60L14	G4-83		G4-97		G4-86
26A10HA18	G4-54,	26A40HA56	G4-54,	26AZ10R56	G4-83	26AZ60L56	G4-83	26Q15L14	G4-50	26Q40LR14	G4-50
	G4-97		G4-97	26AZ15H14	G4-83	26AZ60LR14	G4-83	26Q15L18	G4-50		G4-50
26A10HA56	G4-54,	26A40L14	G4-54	26AZ15H18	G4-83	26AZ60R56	G4-83	26Q15L56	G4-50,		G4-86
	G4-97	26A40L56	G4-54	26AZ15H56	G4-83	26AZ60R14	G4-83		G4-86	26Q40R14	G4-50
26A10L14	G4-54	26A40LR14	G4-54	26AZ15HA14	G4-83	26AZ60R56	G4-83	26Q15LR14	G4-50	26Q40R56	G4-50,
26A10L18	G4-54	26A40LR56	G4-54	26AZ15HA18	G4-83	26BBASE	G4-91	26Q15LR18	G4-50		G4-86
26A10L56	G4-54	26A40R14	G4-54	26AZ15HA56	G4-83	26BRACKET	G4-102	26Q15LR56	G4-50,	26Q50H14	G4-50
26A10LR14	G4-54	26A40R56	G4-54	26AZ15L14	G4-83	26CLSDCOVER			G4-86	26Q50H56	G4-50,
26A10LR18	G4-54	26A50H14	G4-54	26AZ15L18	G4-83		G4-108	26Q15R14	G4-50		G4-86
26A10LR56	G4-54	26A50H56	G4-54	26AZ15L56	G4-83	26DOWN30	G4-104	26Q15R18	G4-50	26Q50HA14	G4-50,
26A10R14	G4-54	26A50HA14	G4-54,	26AZ15LR14	G4-83	26OPENCOVER		26Q15R56	G4-50,		G4-97
26A10R18	G4-54		G4-97	26AZ15LR18	G4-83		G4-108		G4-86	26Q50HA56	G4-50,
26A10R56	G4-54	26A50HA56	G4-54,	26AZ15LR56	G4-83	26PLUGIN	G4-103	26Q20H14	G4-50		G4-97
26A15H14	G4-54		G4-97	26AZ15R14	G4-83	26Q05H14	G4-50	26Q20H56	G4-50,	26Q50L14	G4-50
26A15H18	G4-54	26A50L14	G4-54	26AZ15R18	G4-83	26Q05H18	G4-50		G4-86	26Q50L56	G4-50,
26A15H56	G4-54	26A50L56	G4-54	26AZ15R56	G4-83	26Q05HA14	G4-50,	26Q20HA14	G4-50,		G4-86
26A15HA14	G4-54,	26A50LR14	G4-54	26AZ20H14	G4-83		G4-97		G4-97	26Q50LR14	G4-50
	G4-97	26A50LR56	G4-54	26AZ20H18	G4-83	26Q05HA18	G4-50,	26Q20HA56	G4-50,	26Q50LR56	G4-50,
26A15HA18	G4-54,	26A50R14	G4-54	26AZ20HA14	G4-83		G4-97		G4-97		G4-86
	G4-97	26A50R56	G4-54	26AZ20HA56	G4-83	26Q05L14	G4-50	26Q20L14	G4-50	26Q50R14	G4-50
26A15H14	G4-54	26A60H14	G4-54	26AZ20L14	G4-83	26Q05L18	G4-50	26Q20L56	G4-50,	26Q50R56	G4-50,
26A15H18	G4-54	26A60H56	G4-54	26AZ20L56	G4-83	26Q05LR14	G4-50		G4-86		G4-86
26A15L14	G4-54	26A60HA14	G4-54,	26AZ20LR14	G4-83	26Q05L18	G4-50	26Q20LR14	G4-50,	26Q60H14	G4-50
26A15L18	G4-54		G4-97	26AZ20LR56	G4-83	26Q05R14	G4-50	26Q20LR56	G4-50,	26Q60H56	G4-50,
26A15L56	G4-54	26A60HA56	G4-54,	26AZ20R14	G4-83	26Q05R18	G4-50		G4-86		G4-86
26A15LR14	G4-54	26A60LR14	G4-54	26AZ20R56	G4-83	26Q07H14	G4-50	26Q20R14	G4-50	26Q60HA14	G4-50,
26A15LR18	G4-54	26A60LR56	G4-54	26AZ25H14	G4-83	26Q07H18	G4-50	26Q20R56	G4-50,		G4-97
26A15LR56	G4-54	26A60L14	G4-54	26AZ25H18	G4-83	26Q07H56	G4-50		G4-86	26Q60HA56	G4-50,
26A15R14	G4-54	26A60L56	G4-54	26AZ25HA14	G4-83	26Q07HA14	G4-50,	26Q25H14	G4-50		G4-97
26A15R18	G4-54	26A60LR14	G4-54	26AZ25HA56	G4-83		G4-97	26Q25H56	G4-50,	26Q60L14	G4-50
26A15R56	G4-54	26A60R14	G4-54	26AZ25L14	G4-83	26Q07HA18	G4-50,		G4-86	26Q60L56	G4-50,
26A20H14	G4-54	26A60R56	G4-54	26AZ25L56	G4-83		G4-97	26Q25HA14	G4-50,		G4-86
26A20H56	G4-54	26A205H14	G4-83	26AZ25LR14	G4-83	26Q07HA56	G4-50,		G4-97	26Q60LR14	G4-50
26A20HA14	G4-54,	26A205H18	G4-83	26AZ25LR56	G4-83	26Q07HA56	G4-97	26Q25HA56	G4-50,	26Q60LR56	G4-50,
	G4-97	26A205HA14	G4-83	26AZ25R14	G4-83	26Q07L14	G4-50		G4-97		G4-86
26A20HA56	G4-54,	26A205HA18	G4-83	26AZ25R14	G4-83	26Q07L18	G4-50	26Q25L14	G4-50	26Q60R14	G4-50
	G4-97	26A205L14	G4-83	26AZ25R56	G4-83	26Q07L56	G4-50	26Q25L56	G4-50,	26Q60R56	G4-50,
26A20L14	G4-54	26A205L18	G4-83	26AZ30H14	G4-83	26Q07LR14	G4-50		G4-86		G4-86
26A20L56	G4-54	26A205LR14	G4-83	26AZ30H18	G4-83	26Q07LR18	G4-50	26Q25LR14	G4-50	26QZ05H14	G4-81
26A20LR14	G4-54	26A205LR18	G4-83	26AZ30HA14	G4-83	26Q07LR56	G4-50	26Q25LR56	G4-50,	26QZ05H18	G4-81
26A20LR56	G4-54	26A205LR18	G4-83	26AZ30HA56	G4-83	26Q07R14	G4-50		G4-86	26QZ05HA14	G4-81
26A20R14	G4-54	26A205R14	G4-83	26AZ30HA56	G4-83	26Q07R18	G4-50	26Q25R14	G4-50	26QZ05HA18	G4-81
26A20R56	G4-54	26A207H14	G4-83	26AZ30L14	G4-83	26Q07R56	G4-50	26Q25R56	G4-50,	26QZ05L14	G4-81
26A25H14	G4-54	26A207H18	G4-83	26AZ30L18	G4-83	26Q10H14	G4-50		G4-86	26QZ05L18	G4-81
26A25H56	G4-54	26A207H56	G4-83	26AZ30L56	G4-83	26Q10H18	G4-50	26Q30H14	G4-50	26QZ05LR14	G4-81
26A25HA14	G4-54,	26A207HA14	G4-83	26AZ30R14	G4-83	26Q10H56	G4-50	26Q30H56	G4-50,	26QZ05LR18	G4-81
	G4-97	26A207HA18	G4-83	26AZ30R18	G4-83	26Q10HA14	G4-50,		G4-86	26QZ05R14	G4-81
26A25HA56	G4-54,	26A207HA56	G4-83	26AZ40H14	G4-83		G4-97	26Q30HA14	G4-50,	26QZ05R18	G4-81
	G4-97	26A207L14	G4-83	26AZ40H18	G4-83	26Q10HA18	G4-50,		G4-97	26QZ07H14	G4-81
26A25L14	G4-54	26A207L18	G4-83	26AZ40HA56	G4-83		G4-97	26Q30HA56	G4-50,	26QZ07H18	G4-81
26A25L56	G4-54	26A207L56	G4-83	26AZ40L14	G4-83	26Q10HA56	G4-50,		G4-97	26QZ07H56	G4-81
26A25LR14	G4-54	26A207LR14	G4-83	26AZ40L14	G4-83		G4-97	26Q30L14	G4-50	26QZ07HA14	G4-81
26A25LR56	G4-54	26A207LR18	G4-83	26AZ40L56	G4-83	26Q10L14	G4-50			26QZ07HA18	G4-81
				26AZ40LR14	G4-83						

PART NUMBER INDEX



Part No.	Page	Part No.	Page	Part No.	Page	Part No.	Page	Part No.	Page	Part No.	Page
26QZ07HA56	G4-81	26QZ40H56	G4-81	26S25HA	G4-52	272134	G2-53	272452	G2-57	272722	G2-95
26QZ07L14	G4-81	26QZ40HA14	G4-81		G4-97		G2-55		G2-59		G2-125,G2-157
26QZ07L18	G4-81	26QZ40HA56	G4-81	26S25L	G4-52	272135	G2-53		G2-79,G2-157	272726	G2-111
26QZ07L56	G4-81	26QZ40L14	G4-81	26S25LR	G4-52		G2-55	272453	G2-61		G2-113
26QZ07LR14	G4-81	26QZ40L56	G4-81	26S25R	G4-52	272136	G2-53		G2-63		G2-125,G2-157
26QZ07LR18	G4-81	26QZ40LR14	G4-81	26S30H	G4-52		G2-55		G2-79,G2-157	272727	G2-115
26QZ07LR56	G4-81	26QZ40LR56	G4-81	26S30HA	G4-52	272147	G2-53	272454	G2-65		G2-117
26QZ07R14	G4-81	26QZ40R14	G4-81		G4-97		G2-55		G2-79,G2-157		G2-125,G2-157
26QZ07R18	G4-81	26QZ40R56	G4-81	26S30L	G4-52	272150	G2-68	272455	G2-66	275593	G5-51
26QZ07R56	G4-81	26QZ50H14	G4-81	26S30LR	G4-52	272191	G2-68		G2-79,G2-157	275594	G5-51
26QZ10H14	G4-81	26QZ50H56	G4-81	26S30R	G4-52	272192	G2-68	272456	G2-67	275595	G5-51
26QZ10H18	G4-81	26QZ50HA14	G4-81	26S40H	G4-52	272193	G2-68	G2-79	G2-157	275794	G4-125
26QZ10H56	G4-81	26QZ50HA56	G4-81	26S40HA	G4-52	272194	G2-68	272457	G2-68		G4-127
26QZ10HA14	G4-81	26QZ50L14	G4-81		G4-97	272214	G2-65	G2-79	G2-157		G4-129,G4-131
26QZ10HA18	G4-81	26QZ50L56	G4-81	26S40L	G4-52	272215	G2-66	272458	G2-69	275803	G4-112
26QZ10HA56	G4-81	26QZ50LR14	G4-81	26S40LR	G4-52	272216	G2-66	G2-79	G2-157		G4-113
26QZ10L14	G4-81	26QZ50LR56	G4-81	26S40R	G4-52	272217	G2-66	272459	G2-35		G4-114,G4-115
26QZ10L18	G4-81	26QZ50R14	G4-81	26S50H	G4-52	272218	G2-66	G2-79	G2-157		G4-116,G4-117
26QZ10L56	G4-81	26QZ50R56	G4-81	26S50HA	G4-52	272219	G2-66	272460	G2-196		G4-118,G4-119
26QZ10LR14	G4-81	26QZ60H14	G4-81		G4-97	272238	G2-65	272515	G2-29		G4-120,G4-121
26QZ10LR18	G4-81	26QZ60H56	G4-81	26S50L	G4-52	272239	G2-65		G2-79,G2-157		G4-122,G4-123
26QZ10LR56	G4-81	26QZ60HA14	G4-81	26S50LR	G4-52	272240	G2-65	272521	G2-31		G4-124,G4-125
26QZ10R14	G4-81	26QZ60HA56	G4-81	26S50R	G4-52	272250	G2-67	G2-79	G2-157		G4-126,G4-127
26QZ10R18	G4-81	26QZ60L14	G4-81	26S60H	G4-52	272257	G2-67	272594	G2-41		G4-128,G4-129
26QZ10R56	G4-81	26QZ60L56	G4-81	26S60HA	G4-52	272259	G2-63		G2-80,G2-103		G4-130,G4-131
26QZ15H14	G4-81	26QZ60LR14	G4-81		G4-97		G2-67	272600	G2-65	275806	G4-125
26QZ15H18	G4-81	26QZ60LR56	G4-81	26S60L	G4-52		G2-78,G2-212	272601	G2-65		G4-127,G4-129
26QZ15H56	G4-81	26QZ60R14	G4-81	26S60LR	G4-52	272290	G2-67	272604	G2-65		G4-131G5-49
26QZ15HA14	G4-81	26QZ60R56	G4-81	26S60R	G4-52	272291	G2-67	272605	G2-65	275845	G4-127
26QZ15HA18	G4-81	26RISER	G4-93	26SHAFTREV		272292	G2-67	272615	G2-66		G4-131
26QZ15HA56	G4-81	26S05H	G4-52		G4-107	272293	G2-68	272617	G2-66	275853	G4-115
26QZ15L14	G4-81	26S05HA	G4-52	26STBUSH100			G2-69	272625	G2-91		G4-119
26QZ15L18	G4-81	26QZ60L56	G4-97		G4-96		G2-78,G2-212		G2-93		G4-127,G4-131
26QZ15L56	G4-81	26S05L	G4-52	26STBUSH103		272310	G2-66	272626	G2-95	275855	G4-114
26QZ15LR14	G4-81	26S05LR	G4-52		G4-96		G2-73		G2-97		G4-115
26QZ15LR18	G4-81	26S05R	G4-52	26STBUSH104		272313	G2-67	272627	G2-99		G4-118
26QZ15LR56	G4-81	26S07H	G4-52		G4-96		G2-73		G2-101		G4-119
26QZ20H14	G4-81	26S07HA	G4-52	26STBUSH106		272318	G2-68	272628	G2-103		G4-121,G4-123
26QZ20H56	G4-81		G4-97		G4-96		G2-73		G2-105		G4-126,G4-127
26QZ20HA14	G4-81	26S07L	G4-52	26TBUSH100	G4-96	272324	G2-63	272629	G2-107		G4-130,G4-131
26QZ20HA18	G4-81	26S07LR	G4-52	26TBUSH103	G4-96		G2-80		G2-109	275953	G4-117
26QZ20HA56	G4-81	26S07R	G4-52	26TBUSH104	G4-96	272325	G2-49	272630	G2-111		G4-119
26QZ20L14	G4-81	26S10H	G4-52	26TBUSH106	G4-96		G2-80,G2-111		G2-113		G4-122,G4-123
26QZ20L18	G4-81	26S10HA	G4-52		G4-94	272326	G2-53	272631	G2-115		G4-129,G4-131
26QZ20L56	G4-81		G4-97	26ZBASE	G4-91		G2-80,G2-115		G2-117	275954	G4-119
26QZ20LR14	G4-81	26S10L	G4-52	26ZRISER	G4-93	272327	G2-57	272681	G2-51		G4-123,G4-131
26QZ20LR18	G4-81	26S10LR	G4-52	272032	G2-57		G2-59		G2-80,G2-113	275962	G4-119
26QZ20LR56	G4-81	26S10R	G4-52		G2-59		G2-80,G2-119	272685	G2-55		G4-123,G4-131
26QZ20R14	G4-81	26S12H	G4-52	272033	G2-57	272328	G2-61,G2-80		G2-80,G2-117	276001	G4-112
26QZ20R18	G4-81	26S12HA	G4-52		G2-59	272329	G2-65,G2-80	272688	G2-66		G4-116
26QZ20R56	G4-81	26S12L	G4-52	272034	G2-57	272330	G2-66,G2-80		G2-76		G4-120,G4-122
26QZ25H14	G4-81	26S12LR	G4-52		G2-59	272331	G2-67,G2-80	272700	G2-196		G4-124,G4-128
26QZ25H18	G4-81	26S12R	G4-52	272035	G2-57	272332	G2-68,G2-80	272701	G2-196	276002	G4-112
26QZ25HA14	G4-81	26S15H	G4-52		G2-59	272333	G2-69,G2-80	272702	G2-196		G4-116
26QZ25HA18	G4-81	26S15HA	G4-52	272048	G2-57	272369	G2-45	272703	G2-196		G4-120,G4-122
26QZ25HA56	G4-81		G4-97		G2-59		G2-80,G2-107	272704	G2-196		G4-124,G4-128
26QZ25LR14	G4-81	26S15L	G4-52	272056	G2-61	272370	G2-69	272705	G2-196	276004	G4-114
26QZ25LR18	G4-81	26S15LR	G4-52		G2-63	272392	G2-69,G2-73	272708	G2-196		G4-118
26QZ25LR56	G4-81	26S15R	G4-52	272077	G2-61	272395	G2-69	272710	G2-196		G4-121,G4-123
26QZ30H14	G4-81	26S18H	G4-52		G2-63	272396	G2-69	272711	G2-196		G4-126,G4-130
26QZ30H18	G4-81	26S18HA	G4-52	272079	G2-61	272397	G2-69	272712	G2-196	276005	G4-112
26QZ30H56	G4-81	26S18L	G4-52		G2-63	272398	G2-69	272713	G2-196		G4-116
26QZ30HA14	G4-81	26S18LR	G4-52	272080	G2-61	272446	G2-33	272714	G2-196		G4-120,G4-122
26QZ30HA18	G4-81	26S18R	G4-52		G2-63		G2-79,G2-157	272715	G2-196		G4-124,G4-128
26QZ30HA56	G4-81	26S20H	G4-52	272125	G2-53	272450	G2-49	272716	G2-196	276007	G4-114
26QZ30L14	G4-81	26S20HA	G4-52		G2-55		G2-51	272717	G2-196		G4-118
26QZ30L18	G4-81		G4-97	272132	G2-53		G2-79,G2-157	272718	G2-196		G4-121,G4-123
26QZ30L56	G4-81	26S20L	G4-52		G2-55	272451	G2-53	272719	G2-196		G4-126,G4-130
26QZ30LR14	G4-81	26S20LR	G4-52	272133	G2-53		G2-55	272720	G2-196	276008	G4-113
26QZ30LR18	G4-81	26S20R	G4-52		G2-55		G2-79,G2-157	272721	G2-91		G4-120,G4-125
26QZ30R14	G4-81	26S25H	G4-52						G2-125,G2-157		

PART NUMBER INDEX



Part No.	Page	Part No.	Page	Part No.	Page	Part No.	Page	Part No.	Page	Part No.	Page
300302	G3-26, G3-53	303179	G3-32	304635	G3-30, G3-50	30A25R18	G4-60	30AS20LR14	G4-85	30AZ10LR18	G4-83
300305	G3-25, G3-53	303180	G3-32		G3-31	30A25R56	G4-60	30AS20LR18	G4-85	30AZ10R14	G4-83
300903	G3-27, G3-53	303181	G3-32	304636	G3-31, G3-50	30A30H14	G4-60	30AS20LR56	G4-85	30AZ10R18	G4-83
300904	G3-28, G3-53	303182	G3-32		G3-32	30A30H56	G4-60	30AS20R14	G4-85	30AZ15H14	G4-83
300906	G3-27, G3-53	303183	G3-32	304637	G3-32, G3-50	30A30L14	G4-60	30AS20R18	G4-85	30AZ15H18	G4-83
301204	G3-28, G3-53	303184	G3-32		G3-33	30A30L56	G4-60	30AS20R56	G4-85	30AZ15L14	G4-83
301504	G3-29, G3-53	303185	G3-32	304638	G3-33, G3-50	30A30LR14	G4-60	30AS25H14	G4-85	30AZ15L18	G4-83
302104	G3-30, G3-53	303186	G3-32		G3-34	30A30LR56	G4-60	30AS25H18	G4-85	30AZ15LR14	G4-83
302408	G3-31, G3-53	303187	G3-32	304936	G3-45	30A30R14	G4-60	30AS25H56	G4-85	30AZ15LR18	G4-83
302711	G3-32, G3-53	303188	G3-32	304938	G3-45	30A30R56	G4-60	30AS25L14	G4-85	30AZ15R14	G4-83
302713	G3-33, G3-53	303189	G3-32	304939	G3-45	30A40H14	G4-60	30AS25L18	G4-85	30AZ15R18	G4-83
303100	G3-29	303190	G3-32	304940	G3-45	30A40H56	G4-60	30AS25L56	G4-85	30AZ20H14	G4-83
303101	G3-29	303191	G3-32	304941	G3-45	30A40L14	G4-60	30AS25LR14	G4-85	30AZ20H18	G4-83
303102	G3-29	303192	G3-32	304942	G3-45	30A40L56	G4-60	30AS25LR18	G4-85	30AZ20H56	G4-83
303103	G3-29	303193	G3-32	304943	G3-45	30A40LR14	G4-60	30AS25LR56	G4-85	30AZ20L14	G4-83
303104	G3-29	303194	G3-32	304947	G3-45	30A40LR56	G4-60	30AS25R14	G4-85	30AZ20L18	G4-83
303105	G3-29	303196	G3-33	304950	G3-45	30A40R14	G4-60	30AS25R18	G4-85	30AZ20L56	G4-83
303106	G3-29	303197	G3-33		G3-46	30A40R56	G4-60	30AS25R56	G4-85	30AZ20LR14	G4-83
303107	G3-29	303198	G3-33	30A05H14	G4-60	30A50H14	G4-60	30AS30H14	G4-85	30AZ20LR18	G4-83
303108	G3-29	303199	G3-33	30A05H18	G4-60	30A50H56	G4-60	30AS30H56	G4-85	30AZ20LR56	G4-83
303109	G3-29	303200	G3-33	30A05L18	G4-60	30A50L14	G4-60	30AS30L14	G4-85	30AZ20R14	G4-83
303110	G3-29	303201	G3-33	30A05LR14	G4-60	30A50L56	G4-60	30AS30L56	G4-85	30AZ20R18	G4-83
303111	G3-29	303202	G3-33	30A05LR18	G4-60	30A60LR14	G4-60	30AS30LR14	G4-85	30AZ20R56	G4-83
303112	G3-29	303203	G3-33	30A05R14	G4-60	30A60LR56	G4-60	30AS30LR56	G4-85	30AZ25H14	G4-83
303113	G3-29	303204	G3-33	30A05R18	G4-60	30A60R14	G4-60	30AS30R14	G4-85	30AZ25H18	G4-83
303114	G3-29	303205	G3-33	30A07H14	G4-60	30A60R56	G4-60	30AS30R56	G4-85	30AZ25H56	G4-83
303115	G3-29	303206	G3-33	30A07H18	G4-60	30A60H14	G4-60	30AS40H14	G4-85	30AZ25L14	G4-83
303116	G3-29	303207	G3-33	30A07L14	G4-60	30A60H56	G4-60	30AS40H56	G4-85	30AZ25L18	G4-83
303117	G3-29	303208	G3-33	30A07L18	G4-60	30A60L14	G4-60	30AS40L14	G4-85	30AZ25L56	G4-83
303118	G3-29	303209	G3-33	30A07LR14	G4-60	30A60L56	G4-60	30AS40L56	G4-85	30AZ25LR14	G4-83
303138	G3-30	303210	G3-33	30A07LR18	G4-60	30A60LR14	G4-60	30AS40LR14	G4-85	30AZ25LR18	G4-83
303139	G3-30	303211	G3-33	30A07R14	G4-60	30A60LR56	G4-60	30AS40LR56	G4-85	30AZ25LR56	G4-83
303140	G3-30	303212	G3-33	30A07R18	G4-60	30A60R14	G4-60	30AS40R14	G4-85	30AZ25R14	G4-83
303141	G3-30	303213	G3-33	30A10H14	G4-60	30A60R56	G4-60	30AS40R56	G4-85	30AZ25R18	G4-83
303142	G3-30	3035BUSH111		30A10H18	G4-60	30AS05H14	G4-85	30AS50H14	G4-85	30AZ25R56	G4-83
303143	G3-30		G4-96	30A10L14	G4-60	30AS05H18	G4-85	30AS50H56	G4-85	30AZ30H14	G4-83
303144	G3-30	3035FLANGE	G4-95	30A10L18	G4-60	30AS05L14	G4-85	30AS50L14	G4-85	30AZ30H56	G4-83
303145	G3-30	3035SBUSH111		30A10LR14	G4-60	30AS05L18	G4-85	30AS50L56	G4-85	30AZ30L14	G4-83
303146	G3-30		G4-96	30A10LR18	G4-60	30AS05LR14	G4-85	30AS50LR14	G4-85	30AZ30L56	G4-83
303147	G3-30	3035SFLANGE		30A10R14	G4-60	30AS05R14	G4-85	30AS50LR56	G4-85	30AZ30LR14	G4-83
303148	G3-30		G4-95	30A10R18	G4-60	30AS05R18	G4-85	30AS50R14	G4-85	30AZ30LR56	G4-83
303149	G3-30	3035SPACER		30A15H14	G4-60	30AS07H14	G4-85	30AS50R56	G4-85	30AZ30R14	G4-83
303150	G3-30		G4-91	30A15H18	G4-60	30AS07H18	G4-85	30AS60H14	G4-85	30AZ30R56	G4-83
303151	G3-30	3035STBUSH106		30A15L14	G4-60	30AS07L14	G4-85	30AS60H56	G4-85	30AZ40H14	G4-83
303152	G3-30		G4-96	30A15L18	G4-60	30AS07L18	G4-85	30AS60L14	G4-85	30AZ40H56	G4-83
303153	G3-30	3035STBUSH107		30A15LR14	G4-60	30AS07LR14	G4-85	30AS60L56	G4-85	30AZ40L14	G4-83
303154	G3-30		G4-96	30A15LR18	G4-60	30AS07LR18	G4-85	30AS60LR14	G4-85	30AZ40L56	G4-83
303155	G3-30	3035STBUSH108		30A15R14	G4-60	30AS07R14	G4-85	30AS60LR56	G4-85	30AZ40LR14	G4-83
303156	G3-30		G4-96	30A15R18	G4-60	30AS07R18	G4-85	30AS60R14	G4-85	30AZ40LR56	G4-83
303157	G3-31	3035TBUSH106		30A20H14	G4-60	30AS10H14	G4-85	30AS60R56	G4-85	30AZ40R14	G4-83
303158	G3-31		G4-96	30A20H18	G4-60	30AS10H18	G4-85	30AZ05H14	G4-83	30AZ40R56	G4-83
303159	G3-31	3035TBUSH107		30A20H56	G4-60	30AS10L14	G4-85	30AZ05H18	G4-83	30AZ50H14	G4-83
303160	G3-31		G4-96	30A20L14	G4-60	30AS10L18	G4-85	30AZ05L14	G4-83	30AZ50H56	G4-83
303161	G3-31	3035TBUSH108		30A20L18	G4-60	30AS10LR14	G4-85	30AZ05L18	G4-83	30AZ50L14	G4-83
303162	G3-31		G4-96	30A20L56	G4-60	30AS10LR18	G4-85	30AZ05LR14	G4-83	30AZ50L56	G4-83
303163	G3-31	304603	G5-50	30A20LR14	G4-60	30AS10R14	G4-85	30AZ05LR18	G4-83	30AZ50LR14	G4-83
303164	G3-31	304627	G3-23, G3-50	30A20LR18	G4-60	30AS10R18	G4-85	30AZ05R14	G4-83	30AZ50LR56	G4-83
303165	G3-31		G3-50	30A20LR56	G4-60	30AS15H14	G4-85	30AZ05R18	G4-83	30AZ50R14	G4-83
303166	G3-31	304628	G3-24, G3-50	30A20R14	G4-60	30AS15H18	G4-85	30AZ07H14	G4-83	30AZ50R56	G4-83
303167	G3-31		G3-50	30A20R18	G4-60	30AS15L14	G4-85	30AZ07H18	G4-83	30AZ60H14	G4-83
303168	G3-31	304629	G3-25, G3-50	30A20R56	G4-60	30AS15L18	G4-85	30AZ07L14	G4-83	30AZ60H56	G4-83
303169	G3-31		G3-50	30A25H14	G4-60	30AS15LR14	G4-85	30AZ07L18	G4-83	30AZ60L14	G4-83
303170	G3-31	304630	G3-26, G3-50	30A25H18	G4-60	30AS15LR18	G4-85	30AZ07LR14	G4-83	30AZ60L56	G4-83
303171	G3-31		G3-50	30A25H56	G4-60	30AS15R14	G4-85	30AZ07LR18	G4-83	30AZ60LR14	G4-83
303172	G3-31	304631	G3-27, G3-50	30A25L14	G4-60	30AS15R18	G4-85	30AZ07R14	G4-83	30AZ60LR56	G4-83
303173	G3-31		G3-50	30A25L18	G4-60	30AS20H14	G4-85	30AZ07R18	G4-83	30AZ60R14	G4-83
303174	G3-31	304632	G3-28, G3-50	30A25L56	G4-60	30AS20H18	G4-85	30AZ10H14	G4-83	30AZ60R56	G4-83
303175	G3-31		G3-50	30A25LR14	G4-60	30AS20H56	G4-85	30AZ10H18	G4-83	30BASE	G4-91
303176	G3-32	304633	G3-29, G3-50	30A25LR18	G4-60	30AS20L14	G4-85	30AZ10L14	G4-83	30BRACKET	G4-102
303177	G3-32		G3-50	30A25LR56	G4-60	30AS20L18	G4-85	30AZ10L18	G4-83	30CLSDCOVER	
303178	G3-32		G3-50	30A25R14	G4-60	30AS20L56	G4-85	30AZ10LR14	G4-83		G4-108

PART NUMBER INDEX



Part No.	Page	Part No.	Page	Part No.	Page	Part No.	Page	Part No.	Page
334863	G4-106, G4-112, G4-116, G4-120, G4-122, G4-124, G4-128	351097	G2-90, G2-92, G2-148, G2-150	353069	G2-99, G2-101	356058	G2-110	35A10H18	G4-66
334895	G4-126, G4-130	351147	G2-120	353070	G2-99, G2-101	356069	G2-111, G2-113	35A10H21	G4-66
334896	G4-115, G4-119	351148	G2-120	353180	G2-121	356112	G2-94, G2-96, G2-157	35A10L14	G4-66
335330	G4-115, G4-116, G4-121, G4-122, G4-126, G4-128	351149	G2-120	353181	G2-121, G2-157	356149	G2-102, G2-104, G2-157	35A10L18	G4-66
335331	G4-115, G4-116, G4-121, G4-122, G4-126, G4-128	351163	G2-90	353182	G2-121, G2-157	356154	G2-110, G2-112, G2-157	35A10L21	G4-66
335332	G4-118, G4-123, G4-130	351164	G2-90	353183	G2-121	356158	G2-106, G2-108, G2-157	35A10LR14	G4-66
335333	G4-118, G4-123, G4-130	351165	G2-92	354028	G2-103, G2-105	356163	G2-98, G2-100, G2-157	35A10LR18	G4-66
335334	G4-118, G4-123, G4-130	351190	G2-150	354069	G2-103, G2-105	356168	G2-90, G2-92, G2-157	35A10LR21	G4-66
335335	G4-115, G4-116, G4-121, G4-122, G4-126, G4-128	351191	G2-148	354116	G2-196	356182	G2-114, G2-116, G2-148	35A10R14	G4-66
335336	G4-115, G4-121, G4-126	351192	G2-148	354117	G2-196	356183	G2-114, G2-116, G2-148	35A10R18	G4-66
335337	G4-112, G4-120, G4-124	351300	G2-120	354118	G2-196	356184	G2-114, G2-116, G2-148	35A12H11	G4-66
335338	G4-114, G4-117, G4-121, G4-122, G4-126, G4-128	351301	G2-120	354119	G2-196	356240	G2-122	35A12H14	G4-66
335339	G4-117, G4-122, G4-150	351302	G2-120	354120	G2-196	356242	G2-122	35A12H18	G4-66
335340	G4-114, G4-117, G4-121, G4-122, G4-126, G4-128	351303	G2-120	354121	G2-102, G2-104, G2-148, G2-150	356256	G2-114	35A12LR11	G4-66
335341	G4-119, G4-123, G4-130	351327	G2-122	354351	G2-121	356257	G2-114	35A12LR14	G4-66
335342	G4-119, G4-123, G4-130	351328	G2-122	354352	G2-121, G2-157	356269	G2-115, G2-117	35A12LR18	G4-66
335343	G4-119, G4-123, G4-130	351329	G2-122	354353	G2-121, G2-157	356275	G2-122	35A12R14	G4-66
335344	G4-114, G4-121, G4-126	351332	G2-122	354354	G2-121, G2-157	356276	G2-122, G2-157	35A12R18	G4-66
351025	G2-120, G2-157	351333	G2-122	354355	G2-121, G2-106, G2-108, G2-148, G2-150	355072	G2-106, G2-108, G2-148, G2-150	35A12R21	G4-66
351026	G2-120, G2-157	351334	G2-122	355076	G2-196	355077	G2-196	35A12R21	G4-66
351027	G2-120	352052	G2-94, G2-96, G2-148, G2-150	355078	G2-196	355079	G2-196	35A12R18	G4-66
351028	G2-120	352053	G2-94, G2-96, G2-148, G2-150	355079	G2-196	355168	G2-107, G2-109	35A12R14	G4-66
351069	G2-91, G2-93	352065	G2-94	355079	G2-196	355169	G2-107, G2-109	35A12R18	G4-66
351086	G2-90, G2-92, G2-148, G2-150	352066	G2-94	355079	G2-196	355175	G2-106, G2-108, G2-148, G2-150	35A12R14	G4-66
351087	G2-90, G2-92, G2-148, G2-150	352069	G2-95, G2-97	355079	G2-196	355176	G2-106, G2-108, G2-148, G2-150	35A12R18	G4-66
351094	G2-90, G2-92, G2-148, G2-150	352090	G2-94, G2-96, G2-148, G2-150	355079	G2-196	355177	G2-106, G2-108, G2-148, G2-150	35A12R14	G4-66
351095	G2-90, G2-92, G2-148, G2-150	352091	G2-94, G2-96, G2-148, G2-150	355079	G2-196	355225	G2-121, G2-157	35A12R18	G4-66
351096	G2-90, G2-92, G2-148, G2-150	352092	G2-94, G2-96, G2-148, G2-150	355079	G2-196	355226	G2-121, G2-157	35A12R14	G4-66
		352093	G2-94, G2-96, G2-148, G2-150	355079	G2-196	355227	G2-121, G2-157	35A12R18	G4-66
		352160	G2-120	355079	G2-196	355228	G2-121, G2-157	35A12R14	G4-66
		352161	G2-120	355079	G2-196	355229	G2-121, G2-157	35A12R18	G4-66
		352162	G2-120	355079	G2-196	355230	G2-121, G2-157	35A12R14	G4-66
		352163	G2-120	355079	G2-196	355231	G2-121, G2-157	35A12R18	G4-66
		352186	G2-120, G2-157	355079	G2-196	355232	G2-121, G2-157	35A12R14	G4-66
		352187	G2-120, G2-157	355079	G2-196	355233	G2-121, G2-157	35A12R18	G4-66
		352188	G2-120	355079	G2-196	355234	G2-121, G2-157	35A12R14	G4-66
		352189	G2-120	355079	G2-196	355235	G2-121, G2-157	35A12R18	G4-66
		352190	G2-150	355079	G2-196	355236	G2-121, G2-157	35A12R14	G4-66
		352191	G2-148	355079	G2-196	355237	G2-121, G2-157	35A12R18	G4-66
		352192	G2-148	355079	G2-196	355238	G2-121, G2-157	35A12R14	G4-66
		352193	G2-148	355079	G2-196	355239	G2-121, G2-157	35A12R18	G4-66
		352194	G2-148	355079	G2-196	355240	G2-121, G2-157	35A12R14	G4-66
		352195	G2-148	355079	G2-196	355241	G2-121, G2-157	35A12R18	G4-66
		352196	G2-148	355079	G2-196	355242	G2-121, G2-157	35A12R14	G4-66
		352197	G2-148	355079	G2-196	355243	G2-121, G2-157	35A12R18	G4-66
		352198	G2-148	355079	G2-196	355244	G2-121, G2-157	35A12R14	G4-66
		352199	G2-148	355079	G2-196	355245	G2-121, G2-157	35A12R18	G4-66
		352200	G2-148	355079	G2-196	355246	G2-121, G2-157	35A12R14	G4-66
		352201	G2-148	355079	G2-196	355247	G2-121, G2-157	35A12R18	G4-66
		352202	G2-148	355079	G2-196	355248	G2-121, G2-157	35A12R14	G4-66
		352203	G2-148	355079	G2-196	355249	G2-121, G2-157	35A12R18	G4-66
		352204	G2-148	355079	G2-196	355250	G2-121, G2-157	35A12R14	G4-66
		352205	G2-148	355079	G2-196	355251	G2-121, G2-157	35A12R18	G4-66
		352206	G2-148	355079	G2-196	355252	G2-121, G2-157	35A12R14	G4-66
		352207	G2-148	355079	G2-196	355253	G2-121, G2-157	35A12R18	G4-66
		352208	G2-148	355079	G2-196	355254	G2-121, G2-157	35A12R14	G4-66
		352209	G2-148	355079	G2-196	355255	G2-121, G2-157	35A12R18	G4-66
		352210	G2-148	355079	G2-196	355256	G2-121, G2-157	35A12R14	G4-66
		352211	G2-148	355079	G2-196	355257	G2-121, G2-157	35A12R18	G4-66
		352212	G2-148	355079	G2-196	355258	G2-121, G2-157	35A12R14	G4-66
		352213	G2-148	355079	G2-196	355259	G2-121, G2-157	35A12R18	G4-66
		352214	G2-148	355079	G2-196	355260	G2-121, G2-157	35A12R14	G4-66
		352215	G2-148	355079	G2-196	355261	G2-121, G2-157	35A12R18	G4-66
		352216	G2-148	355079	G2-196	355262	G2-121, G2-157	35A12R14	G4-66
		352217	G2-148	355079	G2-196	355263	G2-121, G2-157	35A12R18	G4-66
		352218	G2-148	355079	G2-196	355264	G2-121, G2-157	35A12R14	G4-66
		352219	G2-148	355079	G2-196	355265	G2-121, G2-157	35A12R18	G4-66
		352220	G2-148	355079	G2-196	355266	G2-121, G2-157	35A12R14	G4-66
		352221	G2-148	355079	G2-196	355267	G2-121, G2-157	35A12R18	G4-66
		352222	G2-148	355079	G2-196	355268	G2-121, G2-157	35A12R14	G4-66
		352223	G2-148	355079	G2-196	355269	G2-121, G2-157	35A12R18	G4-66
		352224	G2-148	355079	G2-196	355270	G2-121, G2-157	35A12R14	G4-66
		352225	G2-148	355079	G2-196	355271	G2-121, G2-157	35A12R18	G4-66
		352226	G2-148	355079	G2-196	355272	G2-121, G2-157	35A12R14	G4-66
		352227	G2-148	355079	G2-196	355273	G2-121, G2-157	35A12R18	G4-66
		352228	G2-148	355079	G2-196	355274	G2-121, G2-157	35A12R14	G4-66
		352229	G2-148	355079	G2-196	355275	G2-121, G2-157	35A12R18	G4-66
		352230	G2-148	355079	G2-196	355276	G2-121, G2-157	35A12R14	G4-66
		352231	G2-148	355079	G2-196	355277	G2-121, G2-157	35A12R18	G4-66
		352232	G2-148	355079	G2-196	355278	G2-121, G2-157	35A12R14	G4-66
		352233	G2-148	355079	G2-196	355279	G2-121, G2-157	35A12R18	G4-66
		352234	G2-148	355079	G2-196	355280	G2-121, G2-157	35A12R14	G4-66
		352235	G2-148	355079	G2-196	355281	G2-121, G2-157	35A12R18	G4-66
		352236	G2-148	355079	G2-196	355282	G2-121, G2-157	35A12R14	G4-66
		352237	G2-148	355079	G2-196	355283	G2-121, G2-157	35A12R18	G4-66
		352238	G2-148	355079	G2-196	355284	G2-121, G2-157	35A12R14	G4-66
		352239	G2-148	355079	G2-196	355285	G2-121, G2-157	35A12R18	G4-66
		352240	G2-148	355079	G2-196	355286	G2-121, G2-157	35A12R14	G4-66
		352241	G2-148	355079	G2-196	355287	G2-121, G2-157	35A12R18	G4-66
		352242	G2-148	355079	G2-196	355288	G2-121, G2-157	35A12R14	G4-66
		352243	G2-148	355079	G2-196	355289	G2-121, G2-157	35A12R18	G4-66
		352244	G2-148	355079					

PART NUMBER INDEX



Part No.	Page	Part No.	Page	Part No.	Page	Part No.	Page	Part No.	Page	Part No.	Page
35AS25L18	G4-85	35AZ10H21	G4-83	35AZ260R56	G4-83	35Q15L56	G4-86	35Q50LR56	G4-62	35QS25L14	G4-84
35AS25LR14	G4-85	35AZ10L14	G4-83	35AZj60LR14	G4-83	35Q15LR14	G4-62		G4-86	35QS25L18	G4-84
35AS25LR18	G4-85	35AZ10L18	G4-83	35BASE	G4-91	35Q15LR18	G4-62	35Q50R14	G4-62	35QS25LR14	G4-84
35AS25R14	G4-85	35AZ10L21	G4-83	35BRACKET	G4-102	35Q15LR56	G4-86	35Q50R56	G4-62	35QS25LR18	G4-84
35AS25R18	G4-85	35AZ10LR14	G4-83		G4-102	35Q15R14	G4-62		G4-86	35QS25R14	G4-84
35AS30H14	G4-85	35AZ10LR18	G4-83	35CLSDCOVER	G4-108	35Q15R18	G4-62	35Q60H14	G4-62	35QS25R18	G4-84
35AS30H18	G4-85	35AZ10R14	G4-83		G4-108	35Q15R56	G4-86	35Q60H56	G4-62	35QS30H14	G4-84
35AS30H56	G4-85	35AZ10R18	G4-83	35MTR14	G4-64	35Q20H14	G4-62		G4-86	35QS30H18	G4-84
35AS30L14	G4-85	35AZ10R21	G4-83	35MTR18	G4-64	35Q20H18	G4-62	35Q60L14	G4-62	35QS30H56	G4-84
35AS30L18	G4-85	35AZ15H14	G4-83	35MTR21	G4-64	35Q20H56	G4-86	35Q60L56	G4-62	35QS30L14	G4-84
35AS30L56	G4-85	35AZ15H18	G4-83	35MTR21	G4-64	35Q20L14	G4-62		G4-86	35QS30L18	G4-84
35AS30LR14	G4-85	35AZ15L14	G4-83	35MTR21	G4-64	35Q20L18	G4-62	35Q60LR14	G4-62	35QS30L56	G4-84
35AS30LR18	G4-85	35AZ15L18	G4-83	35MTR56	G4-64	35Q20L56	G4-86	35Q60LR56	G4-62	35QS30LR14	G4-84
35AS30LR56	G4-85	35AZ15R14	G4-83	35MTR56	G4-64	35Q20R14	G4-62		G4-86	35QS30LR18	G4-84
35AS30R14	G4-85	35AZ15R18	G4-83		G4-90	35Q20R18	G4-62	35Q60R14	G4-62	35QS30LR56	G4-84
35AS30R18	G4-85	35AZ15R14	G4-83	35OPENCOVER	G4-108	35Q20R56	G4-86	35Q60R56	G4-62	35QS30R14	G4-84
35AS30R56	G4-85	35AZ15R18	G4-83		G4-108	35Q20R14	G4-62		G4-86	35QS30R18	G4-84
35AS40H14	G4-85	35AZ20H14	G4-83	35PLUGIN	G4-103	35Q20R18	G4-62	35QS05H14	G4-84	35QS30R56	G4-84
35AS40H18	G4-85	35AZ20H18	G4-83	35Q05H14	G4-62	35Q20R56	G4-86	35QS05H18	G4-84	35QS40H14	G4-84
35AS40H56	G4-85	35AZ20L14	G4-83	35Q05H18	G4-62	35Q25H14	G4-62	35QS05H21	G4-84	35QS40H18	G4-84
35AS40L14	G4-85	35AZ20L18	G4-83	35Q05H21	G4-62	35Q25H18	G4-62	35QS05L14	G4-84	35QS40H56	G4-84
35AS40L18	G4-85	35AZ20LR14	G4-83	35Q05L14	G4-62	35Q25H56	G4-86	35QS05L18	G4-84	35QS40L14	G4-84
35AS40L56	G4-85	35AZ20LR18	G4-83	35Q05L18	G4-62	35Q25L14	G4-62	35QS05L21	G4-84	35QS40L18	G4-84
35AS40LR14	G4-85	35AZ20R14	G4-83	35Q05L21	G4-62	35Q25L18	G4-62	35QS05LR14	G4-84	35QS40L56	G4-84
35AS40LR18	G4-85	35AZ20R18	G4-83	35Q05LR14	G4-62	35Q25L56	G4-86	35QS05LR18	G4-84	35QS40LR14	G4-84
35AS40LR56	G4-85	35AZ25H14	G4-83	35Q05LR18	G4-62	35Q25LR14	G4-62	35QS05LR21	G4-84	35QS40LR18	G4-84
35AS40R14	G4-85	35AZ25H18	G4-83	35Q05LR21	G4-62	35Q25LR18	G4-62	35QS05R14	G4-84	35QS40LR56	G4-84
35AS40R18	G4-85	35AZ25L14	G4-83	35Q05R14	G4-62	35Q25LR56	G4-86	35QS05R18	G4-84	35QS40R14	G4-84
35AS40R56	G4-85	35AZ25L18	G4-83	35Q05R18	G4-62	35Q25R14	G4-62	35QS05R21	G4-84	35QS40R18	G4-84
35AS50H14	G4-85	35AZ25R14	G4-83	35Q05R21	G4-62	35Q25R18	G4-62	35QS07H14	G4-84	35QS40R56	G4-84
35AS50H56	G4-85	35AZ25LR18	G4-83	35Q07H14	G4-62	35Q25R56	G4-86	35QS07H18	G4-84	35QS50H14	G4-84
35AS50L14	G4-85	35AZ25R14	G4-83	35Q07H18	G4-62	35Q30H14	G4-62	35QS07H21	G4-84	35QS50H56	G4-84
35AS50L56	G4-85	35AZ25R18	G4-83	35Q07H21	G4-62	35Q30H18	G4-62	35QS07L14	G4-84	35QS50L14	G4-84
35AS50LR14	G4-85	35AZ30H14	G4-83	35Q07L14	G4-62	35Q30H56	G4-62	35QS07L18	G4-84	35QS50L56	G4-84
35AS50LR56	G4-85	35AZ30H18	G4-83	35Q07L18	G4-62		G4-86	35QS07L21	G4-84	35QS50LR14	G4-84
35AS50R14	G4-85	35AZ30H56	G4-83	35Q07L21	G4-62	35Q30L14	G4-62	35QS07LR14	G4-84	35QS50LR56	G4-84
35AS50R56	G4-85	35AZ30L14	G4-83	35Q07LR14	G4-62	35Q30L18	G4-62	35QS07LR18	G4-84	35QS50R14	G4-84
35AS60H14	G4-85	35AZ30L18	G4-83	35Q07LR18	G4-62	35Q30L56	G4-62	35QS07LR21	G4-84	35QS50R56	G4-84
35AS60H56	G4-85	35AZ30L56	G4-83	35Q07LR21	G4-62		G4-86	35QS07R14	G4-84	35QS60H14	G4-84
35AS60L14	G4-85	35AZ30LR14	G4-83	35Q07R14	G4-62	35Q30LR14	G4-62	35QS07R18	G4-84	35QS60H56	G4-84
35AS60L56	G4-85	35AZ30LR18	G4-83	35Q07R18	G4-62	35Q30LR18	G4-62	35QS07R21	G4-84	35QS60L14	G4-84
35AS60LR14	G4-85	35AZ30LR56	G4-83	35Q07R21	G4-62	35Q30LR56	G4-62	35QS10H14	G4-84	35QS60L56	G4-84
35AS60LR56	G4-85	35AZ30R14	G4-83	35Q10H14	G4-62		G4-86	35QS10H18	G4-84	35QS60LR14	G4-84
35AS60R14	G4-85	35AZ30R18	G4-83	35Q10H18	G4-62	35Q30R14	G4-62	35QS10H21	G4-84	35QS60LR56	G4-84
35AS60R56	G4-85	35AZ30R56	G4-83	35Q10H21	G4-62	35Q30R18	G4-62	35QS10L14	G4-84	35QS60R14	G4-84
35AZ05H14	G4-83	35AZ40H14	G4-83	35Q10L14	G4-62	35Q30R56	G4-62	35QS10L18	G4-84	35QS60R56	G4-84
35AZ05H18	G4-83	35AZ40H18	G4-83	35Q10L18	G4-62		G4-86	35QS10L21	G4-84	35QZ05H14	G4-81
35AZ05H21	G4-83	35AZ40H56	G4-83	35Q10L21	G4-62	35Q40H14	G4-62	35QS10LR14	G4-84	35QZ05H18	G4-81
35AZ05L14	G4-83	35AZ40L14	G4-83	35Q10LR14	G4-62	35Q40H18	G4-62	35QS10LR18	G4-84	35QZ05H21	G4-81
35AZ05L18	G4-83	35AZ40L18	G4-83	35Q10LR18	G4-62	35Q40H56	G4-62	35QS10LR21	G4-84	35QZ05L14	G4-81
35AZ05L21	G4-83	35AZ40L56	G4-83	35Q10LR21	G4-62		G4-86	35QS10R14	G4-84	35QZ05L18	G4-81
35AZ05LR14	G4-83	35AZ40LR14	G4-83	35Q10R14	G4-62	35Q40L14	G4-62	35QS10R18	G4-84	35QZ05L21	G4-81
35AZ05LR18	G4-83	35AZ40LR18	G4-83	35Q10R18	G4-62	35Q40L18	G4-62	35QS10R21	G4-84	35QZ05LR14	G4-81
35AZ05LR21	G4-83	35AZ40LR56	G4-83	35Q10R21	G4-62	35Q40L56	G4-62	35QS15H14	G4-84	35QZ05LR18	G4-81
35AZ05R14	G4-83	35AZ40R14	G4-83	35Q12H14	G4-62		G4-86	35QS15H18	G4-84	35QZ05LR21	G4-81
35AZ05R18	G4-83	35AZ40R18	G4-83	35Q12H18	G4-62	35Q40LR14	G4-62	35QS15L14	G4-84	35QZ05R14	G4-81
35AZ05R21	G4-83	35AZ40R56	G4-83	35Q12H21	G4-62	35Q40LR18	G4-62	35QS15L18	G4-84	35QZ05R18	G4-81
35AZ07H14	G4-83	35AZ50H14	G4-83	35Q12L14	G4-62	35Q40LR56	G4-62	35QS15LR14	G4-84	35QZ05R21	G4-81
35AZ07H18	G4-83	35AZ50H18	G4-83	35Q12L18	G4-62		G4-86	35QS15LR18	G4-84	35QZ07H14	G4-81
35AZ07H21	G4-83	35AZ50H56	G4-83	35Q12L21	G4-62	35Q40R14	G4-62	35QS15R14	G4-84	35QZ07H18	G4-81
35AZ07L14	G4-83	35AZ50L14	G4-83	35Q12LR14	G4-62	35Q40R18	G4-62	35QS15R18	G4-84	35QZ07H21	G4-81
35AZ07L18	G4-83	35AZ50L18	G4-83	35Q12LR18	G4-62	35Q40R56	G4-62	35QS20H14	G4-84	35QZ07L14	G4-81
35AZ07L21	G4-83	35AZ50LR56	G4-83	35Q12LR21	G4-62		G4-86	35QS20H18	G4-84	35QZ07L18	G4-81
35AZ07LR14	G4-83	35AZ50R14	G4-83	35Q12R14	G4-62	35Q50H14	G4-62	35QS20L14	G4-84	35QZ07L21	G4-81
35AZ07LR18	G4-83	35AZ50R18	G4-83	35Q12R18	G4-62	35Q50H56	G4-62	35QS20L18	G4-84	35QZ07LR14	G4-81
35AZ07LR21	G4-83	35AZ60H14	G4-83	35Q12R21	G4-62		G4-86	35QS20LR14	G4-84	35QZ07LR18	G4-81
35AZ07R14	G4-83	35AZ60H56	G4-83	35Q15H14	G4-62	35Q50L14	G4-62	35QS20LR18	G4-84	35QZ07LR21	G4-81
35AZ07R18	G4-83	35AZ60L14	G4-83	35Q15H18	G4-62	35Q50L56	G4-62	35QS20R14	G4-84	35QZ07R14	G4-81
35AZ07R21	G4-83	35AZ60L56	G4-83	35Q15H56	G4-86		G4-86	35QS20R18	G4-84	35QZ07R18	G4-81
35AZ10H14	G4-83	35AZ60LR56	G4-83	35Q15L14	G4-62	35Q50LR14	G4-62	35QS25H14	G4-84	35QZ07R21	G4-81
35AZ10H18	G4-83	35AZ60R14	G4-83	35Q15L18	G4-62			35QS25H18	G4-84	35QZ10H14	G4-81

PART NUMBER INDEX



Part No.	Page	Part No.	Page	Part No.	Page	Part No.	Page	Part No.	Page	Part No.	Page
35QZ10H18	G4-81	35QZ60LR14	G4-81	389722	G2-196	392314	G2-195	40A50LR14	G4-72	40Q40R14	G4-68
35QZ10H21	G4-81	35QZ60LR56	G4-81	389726	G2-196	392315	G2-195	40A50LR18	G4-72	40Q40R18	G4-68
35QZ10L14	G4-81	35QZ60R14	G4-81	389727	G2-196	392316	G2-195	40A50R14	G4-72	40Q50H14	G4-68
35QZ10L18	G4-81	35QZ60R56	G4-81	389728	G2-196	400140	G4-117, G4-119, G4-122, G4-123, G4-129, G4-131	40A50R18	G4-72	40Q50H18	G4-68
35QZ10L21	G4-81	35RISER	G4-93	389900	G2-196	4047MTR14	G4-70, G4-90	40A60H14	G4-72	40Q50H56	G4-86
35QZ10LR14	G4-81	35S05H	G4-64	389901	G2-196	4047MTR18	G4-70, G4-76, G4-90	40A60H18	G4-72	40Q50L14	G4-68
35QZ10LR18	G4-81	35S05L	G4-64	389902	G2-196	4047MTR21	G4-70, G4-76, G4-90	40A60L14	G4-72	40Q50L18	G4-68
35QZ10LR21	G4-81	35S05LR	G4-64	389903	G2-196	4047MTR25	G4-70, G4-76, G4-90	40A60L18	G4-72	40Q50L56	G4-86
35QZ10R14	G4-81	35S05R	G4-64	389904	G2-196	40A05H21	G4-72	40A60LR14	G4-72	40Q50LR14	G4-68
35QZ10R18	G4-81	35S07H	G4-64	389905	G2-196	40A05H25	G4-72	40A60LR18	G4-72	40Q50LR18	G4-68
35QZ10R21	G4-81	35S07L	G4-64	389906	G2-196	40A05L21	G4-72	40A60R14	G4-72	40Q50LR56	G4-86
35QZ15H14	G4-81	35S07LR	G4-64	389907	G2-196	40A05L25	G4-72	40A60R18	G4-72	40Q50R14	G4-68
35QZ15H18	G4-81	35S07R	G4-64	389908	G2-196	40A05LR21	G4-72	40BASE	G4-68, G4-91	40Q50R18	G4-68
35QZ15L14	G4-81	35S10H	G4-64	389909	G2-196	40A05LR25	G4-72	40BRACKET	G4-102	40Q50R56	G4-86
35QZ15L18	G4-81	35S10L	G4-64	389910	G2-196	40A05R21	G4-72	40CLSDCOVER	G4-108	40Q60H14	G4-68
35QZ15LR14	G4-81	35S10LR	G4-64	389911	G2-196	40A05R25	G4-72	40CLSDCOVER	G4-108	40Q60H18	G4-68
35QZ15LR18	G4-81	35S10R	G4-64	389912	G2-196	40A07H21	G4-72	40PLUGIN	G4-103	40Q60H56	G4-86
35QZ15R14	G4-81	35S12H	G4-64	389913	G2-196	40A07H25	G4-72	40Q05H21	G4-68	40Q60L14	G4-68
35QZ15R18	G4-81	35S12L	G4-64	389914	G2-196	40A07L21	G4-72	40Q05H25	G4-68	40Q60L18	G4-68
35QZ20H14	G4-81	35S12LR	G4-64	389915	G2-196	40A07L25	G4-72	40Q05L21	G4-68	40Q60L56	G4-86
35QZ20H18	G4-81	35S12R	G4-64	389916	G2-196	40A07LR21	G4-72	40Q05L25	G4-68	40Q60LR14	G4-68
35QZ20L14	G4-81	35S15H	G4-64	391657	G2-196	40A07LR25	G4-72	40Q05R21	G4-68	40Q60LR18	G4-68
35QZ20L18	G4-81	35S15L	G4-64	391658	G2-196	40A07R21	G4-72	40Q05R25	G4-68	40Q60R56	G4-86
35QZ20LR14	G4-81	35S15LR	G4-64	391659	G2-196	40A07R25	G4-72	40Q05R21	G4-68	40Q60R14	G4-68
35QZ20LR18	G4-81	35S15R	G4-64	392119	G2-196	40A07R25	G4-72	40Q05R25	G4-68	40Q60R18	G4-68
35QZ20R14	G4-81	35S20H	G4-64	392120	G2-196	40A07L21	G4-72	40Q07H21	G4-68	40Q60R56	G4-86
35QZ20R18	G4-81	35S20L	G4-64	392121	G2-196	40A07L25	G4-72	40Q07H25	G4-68	40RISER	G4-93
35QZ25H14	G4-81	35S20LR	G4-64	392270	G2-195	40A07LR21	G4-72	40Q07L21	G4-68	40S05H	G4-70
35QZ25H18	G4-81	35S20R	G4-64	392271	G2-195	40A07LR25	G4-72	40Q07L25	G4-68	40S07L	G4-70
35QZ25L14	G4-81	35S25H	G4-64	392272	G2-195	40A07R21	G4-72	40Q07L21	G4-68	40S07LR	G4-70
35QZ25L18	G4-81	35S25L	G4-64	392273	G2-195	40A07R25	G4-72	40Q07L25	G4-68	40S07R	G4-70
35QZ25LR14	G4-81	35S25LR	G4-64	392274	G2-195	40A10H21	G4-72	40Q07R21	G4-68	40S10H	G4-70
35QZ25LR18	G4-81	35S25R	G4-64	392275	G2-195	40A10L21	G4-72	40Q07R25	G4-68	40S10L	G4-70
35QZ25R14	G4-81	35S30H	G4-64	392276	G2-195	40A10LR21	G4-72	40Q10H21	G4-68	40S10LR	G4-70
35QZ25R18	G4-81	35S30L	G4-64	392277	G2-195	40A10LR21	G4-72	40Q10H21	G4-68	40S10R	G4-70
35QZ25R56	G4-81	35S30LR	G4-64	392278	G2-195	40A10R21	G4-72	40Q10L21	G4-68	40S15H	G4-70
35QZ30H18	G4-81	35S30R	G4-64	392279	G2-195	40A15H18	G4-72	40Q10L21	G4-68	40S15L	G4-70
35QZ30H56	G4-81	35S40H	G4-64	392280	G2-195	40A15H21	G4-72	40Q15H18	G4-68	40S15LR	G4-70
35QZ30L14	G4-81	35S40L	G4-64	392281	G2-195	40A15L18	G4-72	40Q15H21	G4-68	40S15R	G4-70
35QZ30L18	G4-81	35S40LR	G4-64	392282	G2-195	40A15LR18	G4-72	40Q15R21	G4-68	40S15R	G4-70
35QZ30L56	G4-81	35S40R	G4-64	392283	G2-195	40A15LR21	G4-72	40Q15R21	G4-68	40S20H	G4-70
35QZ30LR14	G4-81	35S50H	G4-64	392284	G2-195	40A15R18	G4-72	40Q15L21	G4-68	40S20L	G4-70
35QZ30LR18	G4-81	35S50L	G4-64	392285	G2-195	40A15R18	G4-72	40Q15LR18	G4-68	40S20R	G4-70
35QZ30LR56	G4-81	35S50LR	G4-64	392286	G2-195	40A15R21	G4-72	40Q15LR21	G4-68	40S25H	G4-70
35QZ30R14	G4-81	35S50R	G4-64	392287	G2-195	40A15R21	G4-72	40Q15R18	G4-68	40S25L	G4-70
35QZ30R18	G4-81	35S60H	G4-64	392288	G2-195	40A20H18	G4-72	40Q15R18	G4-68	40S25LR	G4-70
35QZ30R56	G4-81	35S60L	G4-64	392289	G2-195	40A20H21	G4-72	40Q15R21	G4-68	40S25R	G4-70
35QZ40H14	G4-81	35S60LR	G4-64	392290	G2-195	40A20L18	G4-72	40Q20H18	G4-68	40S30H	G4-70
35QZ40H18	G4-81	35S60R	G4-64	392291	G2-195	40A20LR21	G4-72	40Q20H21	G4-68	40S30L	G4-70
35QZ40H56	G4-81	35SBASE	G4-91	392292	G2-195	40A20LR21	G4-72	40Q20L18	G4-68	40S30R	G4-70
35QZ40L14	G4-81	35SHAFTREV		392293	G2-195	40A20R18	G4-72	40Q20L21	G4-68	40S40H	G4-70
35QZ40L18	G4-81		G4-107	392294	G2-195	40A20R21	G4-72	40Q20R18	G4-68	40S40L	G4-70
35QZ40L56	G4-81	35TIEROD	G4-94	392295	G2-195	40A25H18	G4-72	40Q20R21	G4-68	40S40R	G4-70
35QZ40LR14	G4-81	35ZBASE	G4-91	392296	G2-195	40A25L18	G4-72	40Q25H18	G4-68	40S40R	G4-70
35QZ40LR18	G4-81	35ZRISER	G4-93	392297	G2-195	40A25LR18	G4-72	40Q25L18	G4-68	40S50H	G4-70
35QZ40LR56	G4-81	376110	G5-51	392298	G2-195	40A25R18	G4-72	40Q25R18	G4-68	40S50L	G4-70
35QZ40R14	G4-81	389587	G2-196	392299	G2-195	40A30H18	G4-72	40Q30H18	G4-68	40S50R	G4-70
35QZ40R18	G4-81	389588	G2-196	392300	G2-195	40A30L18	G4-72	40Q30LR18	G4-68	40S60L	G4-70
35QZ40R56	G4-81	389589	G2-196	392301	G2-195	40A30LR18	G4-72	40Q30R18	G4-68	40S60LR	G4-70
35QZ50H14	G4-81	389590	G2-196	392302	G2-195	40A30R18	G4-72	40Q40H14	G4-68	40S60R	G4-70
35QZ50H56	G4-81	389591	G2-196	392303	G2-195	40A40H18	G4-72	40Q40H18	G4-68	40SHAFTREV	
35QZ50L14	G4-81	389592	G2-196	392304	G2-195	40A40L14	G4-72	40Q40L18	G4-68		G4-107
35QZ50L18	G4-81	389593	G2-196	392305	G2-195	40A40L18	G4-72	40Q40L18	G4-68		G4-91
35QZ50LR14	G4-81	389594	G2-196	392306	G2-195	40A40LR14	G4-72	40Q40R14	G4-68		G4-96
35QZ50LR56	G4-81	389595	G2-196	392307	G2-195	40A40LR18	G4-72	40Q40R18	G4-68		
35QZ50R14	G4-81	389596	G2-196	392308	G2-195	40A40R14	G4-72	40Q40R18	G4-68		
35QZ50R56	G4-81	389597	G2-196	392309	G2-195	40A40R18	G4-72	40Q40H14	G4-68		
35QZ60H14	G4-81	389598	G2-196	392310	G2-195	40A50H14	G4-72	40Q40L14	G4-68		
35QZ60H56	G4-81	389599	G2-196	392311	G2-195	40A50H18	G4-72	40Q40L18	G4-68		
35QZ60L14	G4-81	389720	G2-196	392312	G2-195	40A50L14	G4-72	40Q40R14	G4-68		
35QZ60L56	G4-81	389721	G2-196	392313	G2-195	40A50L18	G4-72	40Q40R18	G4-68		

PART NUMBER INDEX



Part No.	Page	Part No.	Page	Part No.	Page	Part No.	Page	Part No.	Page	Part No.	Page
40TBUSH111	G4-96	41162601GS	G5-50	411647-34-B	430049 (contd)	47Q05LR25	G4-74	47S20H	G4-76
40TIEROD	G4-94	411626-01-R G4-113, G4-115, G2-61, G2-63,	47Q05R25	G4-74	47S20L	G4-76
411396	G4-119, G4-114, G4-117, G4-119, G2-65, G2-66,	47Q07H25	G4-74	47S20LR	G4-76
..... G4-123, G4-131 G4-121, G4-126 G4-120, G4-121, G2-67, G2-68,	47Q07L25	G4-74	47S20R	G4-76
411397	G4-119,	41162701FS	G5-50 G4-122, G4-123, G2-69, G2-78,	47Q07LR25	G4-74	47S25H	G4-76
..... G4-123, G4-131	41162701FT	G5-50 G4-125, G4-127, G2-157, G3-53	47Q07R25	G4-74	47S25L	G4-76
411402	G4-119,	41162701FV	G5-50 G4-129, G4-131	430120	G2-157	47Q10H21	G4-74	47S25LR	G4-76
..... G4-123, G4-131	41162701FW	G5-50	41164738A	G5-49	430121	G2-157	47Q10H25	G4-74	47S25R	G4-76
411405	G4-113,	411631-58-X	G4-115,	41164738B	G5-49	430159	G2-157	47Q10L21	G4-74	47S30H	G4-76
..... G4-117, G4-119,	41164906D	G5-50	444049	G2-151	47Q10L25	G4-74	47S30L	G4-76
..... G4-120, G4-122, G4-127, G4-131	41168812AA	G5-50	444050	G2-151	47Q10LR21	G4-74	47S30LR	G4-76
..... G4-125, G4-129	411631-63-A	41168812AB	G5-50	444054	G2-151	47Q10LR25	G4-74	47S30R	G4-76
411483	G4-115, G4-113, G4-115,	41168812AC	G5-50	444055	G2-151	47Q10R21	G4-74	47S40H	G4-76
..... G4-119, G4-117, G4-119,	41168812AD	G5-50	444056	G2-151	47Q10R25	G4-74	47S40L	G4-76
..... G4-121, G4-123, G4-125, G4-127,	41168812K	G5-50	444058	G2-196	47Q15H21	G4-74	47S40LR	G4-76
..... G4-127, G4-131 G4-129, G4-131	41168812V	G5-50	444059	G2-196	47Q15L21	G4-74	47S40R	G4-76
411484	G4-115,	41163603B	G5-50	411709-65-H	444061	G2-196	47Q15LR21	G4-74	47S50H	G4-76
..... G4-119, G4-121,	411637-01-A G4-124, G4-126	444062	G2-196	47Q15R21	G4-74	47S50L	G4-76
..... G4-127, G4-131 G4-113, G4-117,	411709-65-Q	47A05H25	G4-78	47Q20H21	G4-74	47S50LR	G4-76
41162024A	G5-49 G4-120, G4-122, G4-128, G4-130	47A05L25	G4-78	47Q20L21	G4-74	47S50R	G4-76
41162024B	G5-49 G4-124, G4-128	41170966AB	G5-53	47A05LR25	G4-78	47Q20LR21	G4-74	47S60H	G4-76
41162024C	G5-49	411637-02-AC	41170966AE	G5-53	47A05R25	G4-78	47Q20R21	G4-74	47S60L	G4-76
41162024D	G5-49 G4-115, G4-119,	41170966AF	G5-53	47A07H25	G4-78	47Q25H18	G4-74	47S60LR	G4-76
41162210AA	G5-50 G4-121, G4-123,	41170966AG	G5-53	47A07L25	G4-78	47Q25H21	G4-74	47S60R	G4-76
41162210AB	G5-50 G4-126, G4-130	41170966AH	G5-53	47A07LR25	G4-78	47Q25L18	G4-74	47SHAFTREV
41162210AD	G5-50	411637-02-AP	41171506A	G5-50	47A07R25	G4-78	47Q25L21	G4-74	47TBUSH115	G4-96
41162210AE	G5-50 G4-115, G4-119,	41171506B	G5-50	47A10H21	G4-78	47Q25LR18	G4-74	47TBUSH203	G4-96
411623-33-A G4-121, G4-123,	417111	G4-124,	47A10H25	G4-78	47Q25LR25	G4-74	47TIEROD	G4-94
..... G4-113, G4-120 G4-126, G4-130 G4-126,	47A10L21	G4-78	47Q25R18	G4-74	50994	G5-51
411623-33-B	411637-02-AR G4-128, G4-130	47A10L25	G4-78	47Q25R21	G4-74	50999	G5-50
..... G4-113, G4-115, G4-119,	417371	G4-124,	47A10LR21	G4-78	47Q30H18	G4-74	51302	G4-113,
..... G4-115, G4-116, G4-121, G4-123, G4-128	47A10LR25	G4-78	47Q30H56	G4-86 G4-119,
..... G4-120, G4-121, G4-126, G4-130	419007	G4-117,	47A10R21	G4-78	47Q30L18	G4-74 G4-117, G4-119,
..... G4-122, G4-124,	411637-02-AV G4-120, G4-122,	47A10R25	G4-78	47Q30L56	G4-86 G4-120, G4-122,
..... G4-126, G4-128 G4-113, G4-117, G4-125, G4-129	47A15H21	G4-78	47Q30LR18	G4-74 G4-123, G4-125,
411623-33-C	G4-115,	411637-02-AY	419009	G4-113,	47A15L21	G4-78	47Q30LR56	G4-86 G4-129, G4-131
..... G4-116, G4-113, G4-117, G4-117, G4-119,	47A15LR21	G4-78	47Q30R18	G4-74	51334	G4-115,
..... G4-121, G4-122, G4-120, G4-122, G4-120, G4-121,	47A15R21	G4-78	47Q30R56	G4-86 G4-119,
..... G4-124, G4-128	411637-02-B	419010	G4-112,	47A20H21	G4-78	47Q40H18	G4-74 G4-121, G4-123,
41162336A	G5-50 G4-115, G4-119, G4-113,	47A20L21	G4-78	47Q40H56	G4-86 G4-126, G4-130
41162336B	G5-50 G4-121, G4-123, G4-122, G4-123,	47A20LR21	G4-78	47Q40L18	G4-74	51335	G4-115,
41162336C	G5-50 G4-126, G4-130 G4-125, G4-127,	47A20R21	G4-78	47Q40L56	G4-86 G4-119,
41162401A	G5-50	411637-02-BA G4-129, G4-131	47A25H18	G4-78	47Q40LR18	G4-74 G4-121, G4-123,
41162401AB	G5-50 G4-115, G4-119,	419010	G4-112,	47A25H21	G4-78	47Q40LR56	G4-86 G4-126, G4-130
41162401AC	G5-50 G4-121, G4-123, G4-113,	47A25L18	G4-78	47Q40R18	G4-74	51492	G4-112,
41162401AD	G5-50 G4-126, G4-130 G4-117, G4-119,	47A25L21	G4-78	47Q40R56	G4-86 G4-113,
41162401AE	G5-50	41163702BH	G5-50 G4-120, G4-121,	47A25LR18	G4-78	47Q50H18	G4-74 G4-114, G4-116,
41162401AG	G5-50	411637-02-E G4-122, G4-123,	47A25LR21	G4-78	47Q50L18	G4-74 G4-117, G4-118,
41162401AH	G5-50 G4-113, G4-117, G4-125, G4-127,	47A25R18	G4-78	47Q50LR18	G4-74	51744	G4-121,
41162401AI	G5-50 G4-120, G4-122, G4-129, G4-131	47A25R21	G4-78	47Q50R18	G4-74 G4-123,
41162401AJ	G5-50	411637-02-N	419036	G4-115,	47A30H18	G4-78	47Q60H18	G4-74 G4-126, G4-130
41162401AW	G5-50 G4-113, G4-117, G4-119,	47A30L18	G4-78	47Q60L18	G4-74	51929	G4-113,
41162518A	G5-50 G4-120, G4-122, G4-121, G4-123,	47A30LR18	G4-78	47Q60LR18	G4-74 G4-115,
411626-01-A G4-124, G4-128 G4-124, G4-125,	47A30R18	G4-78	47Q60R18	G4-74 G4-117, G4-119,
..... G4-112,	41163706E	G5-50 G4-128, G4-129	47A40H18	G4-78	47RISER	G4-93 G4-120, G4-121,
..... G4-114, G4-117,	41163706F	G5-50	419036	G4-115,	47A40L18	G4-78	47S05H	G4-76 G4-122, G4-123,
..... G4-120, G4-121,	41163708A	G5-50 G4-119,	47A40LR18	G4-78	47S05L	G4-76 G4-125, G4-127,
..... G4-122, G4-124,	41163708D	G5-50 G4-121, G4-123,	47A50H18	G4-78	47S05LR	G4-76 G4-129, G4-131
..... G4-126, G4-128	411642-42-E	G4-113 G4-127, G4-131	47A50H21	G4-78	47S05R	G4-76	51952	G4-114,
41162601AC	G5-50	41164246D	G5-50	421111	G5-50	47A50LR18	G4-78	47S07H	G4-76 G4-115, G4-119,
41162601B	G5-50	41164250AB	G5-50	421112	G5-50	47A50LR21	G4-78	47S07L	G4-76 G4-121, G4-123,
41162601BJ	G4-130	41164250AG	G5-50	430048	G1-37,	47A50R18	G4-78	47S07LR	G4-76 G4-127, G4-131
411626-01-BJ	41164250AH	G5-50 G1-45,	47A50R21	G4-78	47S07R	G4-76	54783	G4-117,
..... G4-119, G4-123	41164250AA	G5-50 G1-53, G1-61,	47A60H18	G4-78	47S10H	G4-76 G4-120,
41162601BR	G5-50	41164250AAK	G5-50 G1-123, G2-29,	47A60L18	G4-78	47S10L	G4-76 G4-121, G4-122,
411626-01-C	41164250Z	G5-50 G2-31, G2-33,	47A60R18	G4-78	47S10LR	G4-76 G4-123, G4-124,
..... G4-112,	41164250A	G5-50 G2-35, G2-37,	47BASE	G4-91	47S10R	G4-76 G4-126, G4-128,
..... G4-120, G4-124	41164250AB	G5-50 G2-39, G2-41,	47BRACKET	G4-102	47S15H	G4-76 G4-129, G4-130
41162601D	G5-50	41164250AC	G5-50 G2-43, G2-78,	47PLUGIN	G4-103	47S15L	G4-76		
41162601E	G5-50	41164250AD	G5-50 G2-53, G2-55,	47Q05H25	G4-74	47S15R	G4-76		
41162601GP	G5-50	41164250AE	G5-50 G2-57, G2-59,	47Q05L25	G4-74				
41162601GR	G5-50										

PART NUMBER INDEX



Part No.	Page	Part No.	Page	Part No.	Page	Part No.	Page	Part No.	Page	Part No.	Page
55025	G4-113, G4-117, G4-120, G4-122, G4-125, G4-129	6011253	G5-17, G5-18, G5-19, G5-20, G5-27, G5-34	6011901	G5-39	6-030657	G2-157	900003	G1-37	901097	G1-45
55089	G5-51	6011260	G5-21, G5-29, G5-34	6011918	G5-39	6031046	G5-44	900004	G1-37	901102	G1-37, G1-45
55127	G4-115, G4-121, G4-127	6011277	G5-22, G5-23, G5-31, G5-34	6011925	G5-39	6031053	G5-44	900020	G1-37	901109	G1-45
55582	G4-120, G4-122, G4-124, G4-128	6011284	G5-41	6011932	G5-39	6031060	G5-44	900021	G1-37	901114	G1-123
56110	G5-50	6011291	G5-41	6011949	G5-39	6031077	G5-44	900022	G1-37	901115	G1-123
5611HA456	G4-86,87	6011307	G5-41	6011956	G5-39	6031121	G5-41	900023	G1-37	901126	G1-128
5611HA556	G4-86,87	6011314	G5-41	6011963	G5-39	6031138	G5-41	900024	G1-37	901128	G1-128
58256	G4-113, G4-117, G4-120, G4-122, G4-124, G4-128	6011321	G5-41	6011970	G5-39	6031145	G5-41	900025	G1-37	901129	G1-128
58270	G4-117, G4-122, G4-129	6011338	G5-41	6011987	G5-37	6031152	G5-41	900026	G1-37	901130	G1-128
6002503	G5-35	6011345	G5-41	6011994	G5-37	6031169	G5-41	900027	G1-37	901133	G1-128
6002510	G5-41	6011352	G5-41	6012007	G5-37	6031176	G5-41	900028	G1-37	901134	G1-128
6002527	G5-41	6011369	G5-41	6012052	G5-44	6031183	G5-41	900029	G1-37	901135	G1-128
6002534	G5-41	6011376	G5-41	6012069	G5-44	6031190	G5-41	900070	G1-39	901136	G1-128
6002541	G5-41	6011383	G5-41	6012076	G5-44	6031206	G5-41	900071	G1-39	901137	G1-128
6002558	G5-41	6011390	G5-41	6012083	G5-44	6031213	G5-41	900072	G1-39	901145	G1-124
6002565	G5-41	6011406	G5-41	60200503C	G5-50	6031220	G5-41	900073	G1-39	901146	G1-124
6002572	G5-41	6011413	G5-41	602028-43-F	G4-113, G4-115, G4-117, G4-119, G4-124, G4-126, G4-128, G4-130	6031237	G5-41	900074	G1-39	901147	G1-124
6002589	G5-41	6011420	G5-41	60203712	G5-51	6031244	G5-41	900075	G1-39	901148	G1-124
6002602	G5-40	6011437	G5-41	60207708	G5-51	6031251	G5-41	900080	G1-39	901149	G1-124
6002619	G5-40	6011444	G5-41	60207767	G5-51	6031268	G5-41	900081	G1-39	902000	G1-53
6002626	G5-40	6011451	G5-41	60207767	G5-51	6031275	G5-41	900082	G1-39	902001	G1-53
6002633	G5-40	6011468	G5-41	60222209B	G5-49	6031282	G5-41	900083	G1-39	902002	G1-53
6002640	G5-40	6011475	G5-40	60222209C	G5-49	6031299	G5-41	900090	G1-37	902003	G1-53
6002657	G5-40	6011482	G5-40	60222209W	G5-49	6031305	G5-41	900096	G1-37	902004	G1-53
6009861	G5-35	6011499	G5-40	60222211A	G5-49	6031312	G5-41	900097	G1-37	902020	G1-53
6009878	G5-35	6011505	G5-40	60222220A	G5-49	6031329	G5-41	900109	G1-37	902022	G1-53
6009885	G5-35	6011512	G5-40	60232807C	G5-50	6031336	G5-41	900112	G1-37, G1-45, G1-53, G1-61	902023	G1-53
6009908	G5-35	6011529	G5-40	60232807H	G5-50	6031343	G5-41	900114	G1-123	902024	G1-53
6009915	G5-35	6011536	G5-40	60232807L	G5-50	6031350	G5-41	900115	G1-123	902025	G1-53
6009922	G5-35	6011543	G5-40	60232807M	G5-50	6031367	G5-41	900116	G1-123	902026	G1-53
6009953	G5-35	6011550	G5-40	60232807N	G5-50	6031374	G5-41	900126	G1-128	902027	G1-53
6010997	G5-41	6011567	G5-40	60232807P	G5-50	6031381	G5-41	900128	G1-128	902028	G1-53
6011000	G5-41	6011574	G5-40	60232807R	G5-50	6031398	G5-41	900129	G1-128	902029	G1-53
6011017	G5-41	6011581	G5-40	60232807S	G5-50	6031404	G5-41	900134	G1-128	902030	G1-53
6011024	G5-41	6011598	G5-40	60240821	G5-51	6031411	G5-41	900135	G1-128	902031	G1-53
6011031	G5-41	6011604	G5-40	60240828	G5-51	6031428	G5-41	900136	G1-128	902032	G1-53
6011048	G5-41	6011611	G5-40	60241102	G5-51	6031435	G5-41	901000	G1-45	902033	G1-53
6011055	G5-41	6011628	G5-40	60241163	G5-51	6031442	G5-41	901001	G1-45	902034	G1-53
6011062	G5-41	6011635	G5-40	60241164	G5-51	6031459	G5-41	901002	G1-45	902035	G1-53
6011079	G5-41	6011642	G5-40	60241165	G5-51	6031466	G5-41	901003	G1-45	902036	G1-53
6011086	G5-41	6011659	G5-40	60241166	G5-51	6031473	G5-41	901004	G1-45	902037	G1-53
6011093	G5-41	6011666	G5-40	60241168	G5-51	6031480	G5-41	901020	G1-45	902038	G1-53
6011109	G5-41	6011673	G5-36	60241171	G5-51	6031497	G5-41	901021	G1-45	902060	G1-53
6011116	G5-41	6011680	G5-36	60241202	G5-51	6031503	G5-41	901022	G1-45	902061	G1-53
6011123	G5-41	6011697	G5-36	60241204	G5-51	6031510	G5-41	901023	G1-45	902070	G1-55
6011130	G5-41	6011703	G5-36	60241205	G5-51	6031527	G5-41	901024	G1-45	902071	G1-55
6011147	G5-41	6011710	G5-36	60241207	G5-51	6031534	G5-41	901025	G1-45	902072	G1-55
6011154	G5-41	6011727	G5-36	60241208	G5-51	6031541	G5-41	901026	G1-45	902073	G1-55
6011161	G5-41	6011734	G5-36	60241209	G5-51	6031558	G5-41	901027	G1-45	902074	G1-55
6011178	G5-41	6011741	G5-36	60241210	G5-51	6031565	G5-41	901028	G1-45	902075	G1-55
6011185	G5-41	6011758	G5-40	60241211	G5-51	6031572	G5-42	901030	G1-45	902080	G1-55
6011192	G5-41	6011765	G5-41	60241212	G5-51	6031589	G5-41	901031	G1-45	902081	G1-55
6011215	G5-41	6011772	G5-40	60241215	G5-51	6031596	G5-41	901032	G1-45	902082	G1-55
6011222	G5-41	6011789	G5-37	60241302	G5-51	6031602	G5-41	901033	G1-45	902090	G1-53
6011246	G5-15, G5-16, G5-25, G5-34	6011796	G5-37	60241304	G5-51	6031619	G5-41	901034	G1-45	902096	G1-53
		6011802	G5-37	60241305	G5-51	6031626	G5-41	901035	G1-45	902097	G1-53
		6011818	G5-37	60241307	G5-51	6031633	G5-44	901036	G1-45	902102	G1-53
		6011826	G5-38	60241311	G5-51	6031640	G5-44	901037	G1-45	902109	G1-53
		6011833	G5-38	60241313	G5-51	6031657	G5-44	901070	G1-47	902114	G1-123
		6011840	G5-38	60241315	G5-51	6031664	G5-44	901072	G1-47	902115	G1-123
		6011857	G5-38	60241524C	G5-50	6031725	G5-42	901073	G1-47	902126	G1-128
		6011864	G5-39	60242403	G5-51	6031732	G5-42	901074	G1-47	902127	G1-128
		6011871	G5-39	60242405	G5-51	6031749	G5-42	901075	G1-47	902128	G1-128
		6011888	G5-39	60242407	G5-51	6031756	G5-42	901080	G1-47	902129	G1-128
		6011895	G5-39	60242405	G5-51	6031763	G5-42	901081	G1-47	902130	G1-128
				60245207K	G5-50	6031770	G5-42	901082	G1-47	902133	G1-128
						6031787	G5-42	901083	G1-47	902135	G1-128
						6031794	G5-42	901090	G1-45	902136	G1-128
						900000	G1-37	901096	G1-45	902137	G1-128
						900001	G1-37				
						900002	G1-37				

PART NUMBER INDEX



Part No.	Page	Part No.	Page	Part No.	Page	Part No.	Page	Part No.	Page	Part No.	Page
903000	G1-61	904025	G1-69	905032	G1-77	906040	G1-85	907102	G1-93	910001	G1-111
903001	G1-61	904026	G1-69	905033	G1-77	906041	G1-85	907103	G1-93, G1-107	910002	G1-111
903002	G1-61	904027	G1-69	905034	G1-77	906070	G1-87			910020	G1-111
903003	G1-61	904028	G1-69	905035	G1-77	906071	G1-87	907106	G1-93, G1-101	910021	G1-111
903004	G1-61	904029	G1-69	905036	G1-77	906074	G1-87			910022	G1-111
903020	G1-61	904030	G1-69	905037	G1-77	906075	G1-87	907109	G1-93, G1-101	910023	G1-111
903021	G1-61	904031	G1-69	905038	G1-77	906076	G1-87			910024	G1-111
903022	G1-61	904032	G1-69	905039	G1-77	906082	G1-87	907114	G1-123	910025	G1-111
903023	G1-61	904033	G1-69	905040	G1-77	906083	G1-87	907115	G1-123	910026	G1-111
903024	G1-61	904034	G1-69	905041	G1-77	906084	G1-87	907126	G1-128	910027	G1-111
903025	G1-61	904035	G1-69	905042	G1-77	906090	G1-85	907128	G1-128	910028	G1-111
903026	G1-61	904036	G1-69	905043	G1-77	906096	G1-85	907129	G1-128	910029	G1-111
903027	G1-61	904037	G1-69	905070	G1-79	906097	G1-85	907130	G1-128	910030	G1-111
903028	G1-61	904038	G1-69	905071	G1-79	906102	G1-85	907133	G1-128	910031	G1-111
903029	G1-61	904039	G1-69	905073	G1-79	906103	G1-85	907135	G1-128	910090	G1-111
903030	G1-61	904040	G1-69	905074	G1-79	906106	G1-85	907136	G1-128	910096	G1-111
903031	G1-61	904041	G1-69	905075	G1-79	906109	G1-85	907137	G1-128	910102	G1-111
903032	G1-61	904070	G1-71	905076	G1-79	906114	G1-123	908000	G1-101	910103	G1-111
903033	G1-61	904071	G1-71	905081	G1-79	906115	G1-123	908001	G1-101	910106	G1-111
903034	G1-61	904073	G1-71	905082	G1-79	906126	G1-128	908002	G1-101	910109	G1-111
903035	G1-61	904074	G1-71	905083	G1-79	906128	G1-128	908020	G1-101	910114	G1-123
903036	G1-61	904075	G1-71	905084	G1-79	906129	G1-128	908021	G1-101	910115	G1-123
903037	G1-61	904076	G1-71	905090	G1-77	906130	G1-128	908022	G1-101	910126	G1-128
903038	G1-61	904081	G1-71	905096	G1-77	906133	G1-128	908023	G1-101	910129	G1-128
903039	G1-61	904082	G1-71	905097	G1-77	906135	G1-128	908024	G1-101	910130	G1-128
903060	G1-61	904083	G1-71	905102	G1-77	906136	G1-128	908025	G1-101	910133	G1-128
903061	G1-61	904084	G1-71	905103	G1-77	906137	G1-128	908026	G1-101	910136	G1-128
903070	G1-63	904090	G1-69	905106	G1-77	906145	G1-124	908027	G1-101	910137	G1-128
903071	G1-63	904096	G1-69	905109	G1-77	906146	G1-124	908028	G1-101	912000	G1-115
903072	G1-63	904097	G1-69	905114	G1-123	906147	G1-124	908029	G1-101	912001	G1-115
903073	G1-63	904102	G1-69	905115	G1-123	906148	G1-124	908030	G1-101	912002	G1-115
903074	G1-63	904103	G1-69	905126	G1-128	906149	G1-124	908031	G1-101	912020	G1-115
903075	G1-63	904106	G1-69	905128	G1-128	907000	G1-93	908032	G1-101	912021	G1-115
903076	G1-63	904109	G1-69	905129	G1-128	907001	G1-93	908033	G1-101	912022	G1-115
903080	G1-63	904112	G1-69, G1-77	905130	G1-128	907002	G1-93	908102	G1-101	912023	G1-115
903081	G1-63			905131	G1-128	907003	G1-93	908103	G1-101	912024	G1-115
903082	G1-63		G1-85, G1-93	905133	G1-128	907004	G1-93	908114	G1-123	912025	G1-115
903083	G1-63		G1-101, G1-107	905135	G1-128	907019	G1-93	908115	G1-123	912026	G1-115
903084	G1-63		G1-111, G1-115	905136	G1-128	907021	G1-93	908126	G1-128	912027	G1-115
903090	G1-61	904114	G1-123	905137	G1-128	907022	G1-93	908129	G1-128	912028	G1-115
903096	G1-61	904115	G1-123	905138	G1-128	907023	G1-93	908130	G1-128	912029	G1-115
903097	G1-61	904126	G1-128	905145	G1-124	907024	G1-93	908134	G1-128	912030	G1-115
903102	G1-61	904128	G1-128	905146	G1-124	907025	G1-93	908136	G1-128	912031	G1-115
903109	G1-61	904129	G1-128	905147	G1-124	907026	G1-93	908137	G1-128	912032	G1-115
903114	G1-123	904130	G1-128	905148	G1-124	907027	G1-93	909000	G1-107	912090	G1-115
903115	G1-123	904132	G1-128	905149	G1-124	907028	G1-93	909001	G1-107	912096	G1-115
903126	G1-128	904135	G1-128	906000	G1-85	907029	G1-93	909002	G1-107	912102	G1-115
903127	G1-128	904136	G1-128	906001	G1-85	907030	G1-93	909020	G1-107	912103	G1-115
903128	G1-128	904137	G1-128	906002	G1-85	907031	G1-93	909021	G1-107	912106	G1-115
903129	G1-128	904145	G1-124	906003	G1-85	907032	G1-93	909022	G1-107	912109	G1-115
903130	G1-128	904146	G1-124	906004	G1-85	907033	G1-93	909023	G1-107	912114	G1-123
903132	G1-128	904147	G1-124	906020	G1-85	907034	G1-93	909024	G1-107	912115	G1-123
903134	G1-128	904148	G1-124	906021	G1-85	907035	G1-93	909025	G1-107	912126	G1-128
903135	G1-128	904149	G1-124	906022	G1-85	907036	G1-93	909026	G1-107	912129	G1-128
903136	G1-128	905000	G1-77	906023	G1-85	907037	G1-93	909027	G1-107	912130	G1-128
903137	G1-128	905001	G1-77	906024	G1-85	907038	G1-93	909028	G1-107	912134	G1-128
903145	G1-124	905002	G1-77	906025	G1-85	907039	G1-93	909029	G1-107	912136	G1-128
903146	G1-124	905003	G1-77	906026	G1-85	907070	G1-95	909090	G1-107	912137	G1-128
903147	G1-124	905004	G1-77	906027	G1-85	907071	G1-95	909096	G1-107	DCS01140G	G3-23, G3-48
903148	G1-124	905020	G1-77	906028	G1-85	907074	G1-95	909102	G1-107		
903149	G1-124	905021	G1-77	906029	G1-85	907075	G1-95	909106	G1-107	DCS01140P	G3-23, G3-46
904000	G1-69	905022	G1-77	906030	G1-85	907076	G1-95	909109	G1-107		
904001	G1-69	905023	G1-77	906031	G1-85	907082	G1-95	909114	G1-123	DCS01180G	G3-23, G3-48
904002	G1-69	905024	G1-77	906032	G1-85	907083	G1-95	909115	G1-123		
904003	G1-69	905025	G1-77	906033	G1-85	907084	G1-95	909126	G1-128	DCS01180P	G3-23, G3-46
904004	G1-69	905026	G1-77	906034	G1-85	907090	G1-93, G1-101	909129	G1-128		
904020	G1-69	905027	G1-77	906035	G1-85			909130	G1-128	DCS01210G	G3-23, G3-48
904021	G1-69	905028	G1-77	906036	G1-85	907096	G1-93, G1-101	909134	G1-128		
904022	G1-69	905029	G1-77	906037	G1-85			909136	G1-128	DCS01210P	G3-23, G3-46
904023	G1-69	905030	G1-77	906038	G1-85	907097	G1-93, G1-101	909137	G1-128		
904024	G1-69	905031	G1-77	906039	G1-85			910000	G1-111		

PART NUMBER INDEX



Part No.	Page	Part No.	Page	Part No.	Page	Part No.	Page	Part No.	Page	Part No.	Page
DCS02140G	G3-24, G3-48	DCS05280P	G3-16, G3-27, G3-46	DCS10360P	G3-31, G3-47	TCS04140G	G3-26, G3-48	TCS07250P	G3-29, G3-47	TCS11360G	G3-32, G3-49
DCS02140P	G3-24, G3-46	DCS05320G	G3-27, G3-48	DCS10400G	G3-31, G3-49	TCS04140P	G3-26, G3-46	TCS07280G	G3-29, G3-49	TCS11360P	G3-32, G3-47
DCS02180G	G3-24, G3-48	DCS05320P	G3-27, G3-46	DCS10400P	G3-31, G3-47	TCS04180G	G3-26, G3-48	TCS07280P	G3-29, G3-47	TCS11400G	G3-32, G3-49
DCS02180P	G3-24, G3-46	DCS05360G	G3-27, G3-48	DCS10440G	G3-31, G3-49	TCS04180P	G3-26, G3-46	TCS07320G	G3-29, G3-49	TCS11400P	G3-32, G3-47
DCS02210G	G3-24, G3-48	DCS05360P	G3-27, G3-46	DCS10440P	G3-31, G3-47	TCS04210G	G3-26, G3-48	TCS07320P	G3-29, G3-47	TCS11440G	G3-32, G3-49
DCS02210P	G3-24, G3-46	DCS06210G	G3-28, G3-48	DCS11360G	G3-32, G3-49	TCS04210P	G3-26, G3-46	TCS07360G	G3-29, G3-49	TCS11440P	G3-32, G3-47
DCS02250G	G3-24, G3-48	DCS06210P	G3-28, G3-46	DCS11360P	G3-32, G3-47	TCS04250G	G3-26, G3-48	TCS07360P	G3-29, G3-47	TCS12280G	G3-33, G3-49
DCS02250P	G3-24, G3-46	DCS06250G	G3-28, G3-48	DCS11400G	G3-32, G3-49	TCS04250P	G3-26, G3-46	TCS09250G	G3-30, G3-49	TCS12280P	G3-33, G3-47
DCS03140G	G3-25, G3-48	DCS06250P	G3-28, G3-46	DCS11400P	G3-32, G3-47	TCS04280G	G3-26, G3-48	TCS09250P	G3-30, G3-47	TCS12320G	G3-33, G3-49
DCS03140P	G3-25, G3-46	DCS06280G	G3-28, G3-48	DCS11440G	G3-32, G3-49	TCS04280P	G3-26, G3-46	TCS09280G	G3-30, G3-49	TCS12320P	G3-33, G3-47
DCS03180G	G3-25, G3-48	DCS06280P	G3-28, G3-46	DCS11440P	G3-32, G3-47	TCS05140G	G3-27, G3-48	TCS09280P	G3-30, G3-47	TCS12360G	G3-33, G3-49
DCS03180P	G3-25, G3-46	DCS06320G	G3-28, G3-48	DCS12360G	G3-33, G3-49	TCS05140P	G3-27, G3-46	TCS09320G	G3-30, G3-49	TCS12360P	G3-33, G3-47
DCS03210G	G3-25, G3-48	DCS06320P	G3-28, G3-46	DCS12360P	G3-33, G3-47	TCS05180G	G3-27, G3-48	TCS09320P	G3-30, G3-47	TCS12400G	G3-33, G3-49
DCS03210P	G3-25, G3-46	DCS06360G	G3-28, G3-48	DCS12400G	G3-33, G3-49	TCS05180P	G3-27, G3-46	TCS09360G	G3-30, G3-49	TCS12400P	G3-33, G3-47
DCS03250G	G3-25, G3-48	DCS06360P	G3-28, G3-46	DCS12400P	G3-33, G3-47	TCS05210G	G3-27, G3-48	TCS09360P	G3-30, G3-47	TCS12440G	G3-33, G3-49
DCS03250P	G3-25, G3-46	DCS07250G	G3-29, G3-49	DCS12440G	G3-33, G3-49	TCS05210P	G3-27, G3-46	TCS09400G	G3-30, G3-49	TCS12440P	G3-33, G3-47
DCS03280G	G3-25, G3-48	DCS07250P	G3-29, G3-47	DCS12440P	G3-33, G3-47	TCS05250G	G3-27, G3-48	TCS09400P	G3-30, G3-47	W12TO15BASE	G4-105
DCS03280P	G3-25, G3-46	DCS07280G	G3-29, G3-49	TCS01140G	G3-23, G3-48	TCS05250P	G3-27, G3-46	TCS09440G	G3-30, G3-49	W16TO17BASE	G4-105
DCS04140G	G3-26, G3-48	DCS07280P	G3-29, G3-47	TCS01140P	G3-23, G3-46	TCS05280G	G3-27, G3-48	TCS09440P	G3-30, G3-47	W21TO23BASE	G4-105
DCS04140P	G3-26, G3-46	DCS07320G	G3-29, G3-49	TCS01180G	G3-23, G3-48	TCS05280P	G3-27, G3-46	TCS10250G	G3-31, G3-49	W28TO35BASE	G4-105
DCS04180G	G3-26, G3-48	DCS07320P	G3-29, G3-47	TCS01180P	G3-23, G3-46	TCS06180G	G3-28, G3-48	TCS10250P	G3-31, G3-47		
DCS04180P	G3-26, G3-46	DCS07360G	G3-29, G3-49	TCS02140G	G3-24, G3-48	TCS06180P	G3-28, G3-46	TCS10280G	G3-31, G3-49		
DCS04210G	G3-26, G3-48	DCS07360P	G3-29, G3-47	TCS02140P	G3-24, G3-46	TCS06210G	G3-28, G3-49	TCS10280P	G3-31, G3-47		
DCS04210P	G3-26, G3-46	DCS07400G	G3-29, G3-49	TCS02180G	G3-24, G3-48	TCS06210P	G3-28, G3-47	TCS10320G	G3-31, G3-49		
DCS04250G	G3-26, G3-48	DCS07400P	G3-29, G3-47	TCS02180P	G3-24, G3-46	TCS06250G	G3-28, G3-49	TCS10320P	G3-31, G3-47		
DCS04250P	G3-26, G3-46	DCS07440G	G3-29, G3-49	TCS02210G	G3-24, G3-48	TCS06250P	G3-28, G3-47	TCS10360G	G3-31, G3-49		
DCS04280G	G3-26, G3-48	DCS07440P	G3-29, G3-47	TCS02210P	G3-24, G3-46	TCS06280G	G3-28, G3-49	TCS10360P	G3-31, G3-47		
DCS04280P	G3-26, G3-46	DCS09320G	G3-30, G3-49	TCS03140G	G3-25, G3-48	TCS06280P	G3-28, G3-47	TCS10400G	G3-31, G3-49		
DCS04320G	G3-26, G3-48	DCS09320P	G3-30, G3-49	TCS03140P	G3-25, G3-46	TCS06320G	G3-28, G3-49	TCS10400P	G3-31, G3-47		
DCS04320P	G3-26, G3-46	DCS09360G	G3-30, G3-47	TCS03180G	G3-25, G3-48	TCS06320P	G3-28, G3-47	TCS10440G	G3-31, G3-49		
DCS05210G	G3-27, G3-48	DCS09400G	G3-30, G3-49	TCS03180P	G3-25, G3-46	TCS06360G	G3-28, G3-49	TCS10440P	G3-31, G3-47		
DCS05210P	G3-27, G3-46	DCS09400P	G3-30, G3-47	TCS03210G	G3-25, G3-48	TCS06360P	G3-28, G3-47	TCS11280G	G3-32, G3-49		
DCS05250G	G3-27, G3-48	DCS09440G	G3-30, G3-49	TCS03210P	G3-25, G3-46	TCS07210G	G3-29, G3-49	TCS11280P	G3-32, G3-47		
DCS05250P	G3-27, G3-46	DCS09440P	G3-30, G3-47	TCS03250G	G3-25, G3-48	TCS07210P	G3-29, G3-47	TCS11320G	G3-32, G3-49		
DCS05280G	G3-27, G3-48	DCS10360G	G3-31, G3-49	TCS03250P	G3-25, G3-46	TCS07250G	G3-29, G3-49	TCS11320P	G3-32, G3-47		

NOTES



A			D
ABHS Reducers, TORQUE-ARM	G2-158 - G2-159	Dimensions	
Accessory Compatibility, MAXUM	G3-34	Combination TIGEAR	G5-24 - G5-31
Actual Ratios, MAXUM	G3-74	MAXUM	
Angle of Incline, MAXUM	G3-80	Size 1	G3-23
Application, Combination TIGEAR	G5-53	Size 10	G3-31
Auxiliary Cooling Package		Size 11	G3-32
TXT	G2-79	Size 12	G3-33
TORQUE-ARM II	G1-122	Size 2	G3-24
Auxiliary Seal Kits		Size 3	G3-25
MAXUM	G3-53	Size 4	G3-26
TORQUE-ARM		Size 5	G3-27
SCXT	G2-125	Size 6	G3-28
TXT	G2-79	Size 7	G3-29
		Size 9	G3-30
		TORQUE-ARM	
		TXT	G2-28 - G2-69
		SCXT	G2-90 - G2-119
		HYDROIL	G2-144 - G2-150
B			
Backstop Assemblies			
TORQUE-ARM	G2-78		
TORQUE-ARM II	G1-4		
Backstop Interchange, TORQUE-ARM	G2-211		
Bearing Life Adjustment Factors	G6-9		
Bearing Load Calculations	G6-11		
Belt Guards, TORQUE-ARM			
SCXT	G2-123 - G2-14	Easy Selection	
TXT	G2-76 - G2-77	Combination TIGEAR	G5-6 - G5-12
TORQUE-ARM II	G1-118	MAXUM	G3-7 - G7-22
Bio Disc Reducers, TORQUE-ARM	G2-160	TORQUE-ARM	G2-13 - G2-14
Bolt-On Foot, Combination TIGEAR	G5-32 - G5-33	HXT	G2-128 - G2-143
Bushing Kits - Straight Bore,		SCXT	G2-84 - G2-89
Combination TIGEAR	G5-40	TXT	G2-19 - G2-27
Bushing Kits, Tapered, Combination TIGEAR	G5-41	TORQUE-ARM II	G1-9 - G1-11
			G6-1 - G6-40
		ENGINEERING	
		Engineering/Technical	
		Combination TIGEAR	B5-52
		MAXUM	G3-57 - G3-82
		TIGEAR-2	G4-110 - G4-111
		TORQUE-ARM	G2-196 - G2-212
		TORQUE-ARM II	G1-129 - G1-138
		English Standard Measurement	G6-24
		Exact Ratios Hollow Shaft, Combination TIGEAR	G5-55
		Exact Ratios Solid Shaft, Combination TIGEAR	G5-55
		Expanded Metal Belt Guard, TORQUE-ARM	G2-204
		Expansion of Shafting	
C			
Center Distance, MAXUM	G3-51		
Centrifugal Force	G6-34		
Coefficients of Friction "f"	G6-38		
Combination TIGEAR	G5-1 - G5-56		
Common Conversion Factors	G6-27		
Conveyor Belt FPM to RPM	G6-12		
Cooling Fans			
MAXUM	G3-40		
TORQUE-ARM	G2-80		
TORQUE-ARM II	G1-112		
Coupling Guards, MAXUM	G3-45		

KEYWORD INDEX



F		Load Location Factors, MAXUM	G3-70
Features/Benefits		Long-Term Storage Guidelines, TORQUE-ARM	G2-154
Combination TIGEAR	G5-2 - G5-3	Lubrication	
MAXUM	G3-3 - G3-4	Combination TIGEAR	G5-52
TIGEAR-2	G4-2 - G4-7	MAXUM	G3-76
TORQUE-ARM	G2-3 - G2-9	SYNTHESIZED HYDROCARBON	G5-3
TORQUE-ARM II	G1-3 - G1-6	TIGEAR-2	G4-107
Filter Breathers, TORQUE-ARM	G2-76	TORQUE-ARM II Reducers	G1-132
Flange Mounting Drilling Dimensions		TORQUE-ARM Reducers	G2-192
TORQUE-ARM TXT	G2-201		
Flywheel Formulas	G6-34	M	
Formulas & Constants	G6-33	Maintenance, Combination TIGEAR	G5-54
		Material Characteristics	G6-13
G		Mathematical Equations	G6-35
GRID-LIGN Couplings, MAXUM	G3-48	Maximum Input & Drive Speeds	
		TORQUE-ARM, TXT, SCXT	G2-205
		TORQUE-ARM II	G1-130
H		MAXUM	G3-1 - G3-82
Hard Mounting, MAXUM	G3-81	Metric Standard Measurement & Conversion	G6-26
Hardness Comparison	G6-38	Modification/Accessories	
HD Baseplate, MAXUM	G3-38	Combination TIGEAR	G5-34 - G5-44
Heat Exchange, MAXUM	G3-40	MAXUM	G3-34 - G3-54
Hi-Low Bracket Kits, Combination TIGEAR	G5-39	TIGEAR-2	G4-92 - G4-109
How To Order		TORQUE-ARM	
Combination TIGEAR	G5-5	SCXT	G2-120 - G2-125
MAXUM	G3-6	TXT	G2-70 - G2-80
TIGEAR-2	G4-9	Motor Mounting Bolt Kit, MAXUM	G3-46 - G3-49
HYDROIL Reducers, TORQUE-ARM	G2-9	Motor Mounts, TORQUE-ARM, TXT	G2-72 - G2-75
HYDROIL TORQUE-ARM Shaft Mount Reducers	G2-126 - G2-143	Mounting Base, TIGEAR-2	G4-16 - G4-81
HYDROIL Vane Motors for TXT Reducers	G2-144 - G2-150	Mounting Positions	
		Combination TIGEAR	G5-32 - G5-33
I		TIGEAR-2	G4-90 - G4-91
IEC Metric Motor Adapters,	G5-43	TORQUE-ARM	
Combination TIGEAR		SCXT	G2-213
Input Horsepower Ratings, MAXUM	G3-60	TXT	G2-202
Installation, Combination TIGEAR	G5-52	TORQUE-ARM II	G1-134
J		N	
J-Mount Base Kits		Natural Frequency, MAXUM	G3-81
Combination TIGEAR	G5-38	Nomenclature	
TIGEAR-2	G4-94	Combination TIGEAR	G5-5
		MAXUM	G3-5
L		TIGEAR-2	G4-9
Level I, Level II Rebuild Kits, TORQUE-ARM, TXT	G2-196	TORQUE-ARM	
Level I Rebuild Kits, TORQUE-ARM II	G2-196		
Load Classification, MAXUM	G3-16		

Nomenclature (continued)

HXT	G2-11 - G2-12
SCXT	G2-11 - G2-12
TXT	G2-11 - G2-12
TORQUE-ARM II	G1-8

O

Oil Capacities, MAXUM	G3-77
Oil Levels, MAXUM	G3-77
Oil Viscosity Classification	G6-23
Optional Drive Shafts, TORQUE-ARM, SCXT	G2-120 - G2-122
Options, MAXUM	G3-4
Output Flange Kit	
TIGEAR-2	G4-97
Combination TIGEAR	G5-36
Output Torque Ratings, MAXUM	G3-61
Overhung Load	
TIGEAR-2	G4-10
Engineering	G6-35
MAXUM	G3-72
TORQUE-ARM	G2-205

P

PARA-FLEX Couplings	G3-46
Plug-In Output Shaft Kit(s)	
TIGEAR-2	G4-105
Combination TIGEAR	G5-42
Properties of Sections	G6-37

R

Related Products	
MAXUM	G3-55 - G3-56
TORQUE-ARM	
HYDROIL, HXT	G2-152 - G2-155
TXT Reducers	G2-157 - G2-196
TORQUE-ARM II Reducers	G1-123 - G1-127
Renewal Parts	
TIGEAR-2	G4-112 - G4-133
Combination TIGEAR	G5-45 - G5-52
TORQUE-ARM	G2-196
TORQUE-ARM II	G1-128
Replacement Interchange, TORQUE-ARM, TXT	G2-210
Resonance, MAXUM	G3-81

Riser Block Kits

TIGEAR-2	G4-95
Combination TIGEAR	G5-37
Rod Mounting Positions, TORQUE-ARM, TXT	G2-202
Rotational Inertia, Combination TIGEAR	G5-56

S

Scoop Mount, MAXUM	G3-16
Scoop Mount Motors/Reducers, MAXUM	G3-41
Screw Conveyor Drive SCXT Reducers	G2-81 - G2-119
Screw Conveyor Drives, SCXT	G2-7
Selection	
Combination TIGEAR	G5-12 - G5-23
MAXUM	G3-23 - G3-33
Size 1	G3-23
Size 10	G3-31
Size 11	G3-32
Size 12	G3-33
Size 2	G3-24
Size 3	G3-25
Size 4	G3-26
Size 5	G3-27
Size 6	G3-28
Size 7	G3-29
Size 9	G3-30
TIGEAR -2	G4-10 - G4-15
Horsepower Method	G4-11
Torque Method	G4-11
TORQUE-ARM	
HXT	G2-128 - G2-143
SCXT	G2-83 - G2-89
TXT	G2-126 - G2-127
TORQUE-ARM II	G1-12 - G1-35
Separate Reducers, MAXUM	G3-8
Service Factors	
TIGEAR-2	G4-10 - G4-15
MAXUM	G3-7
Shaft Keyseats/Hub Keyways	G6-18
Shafting/Shaft Diameters	G6-15
Shipping Weights, TIGEAR-2	G4-110
Slide Bases, MAXUM	G3-50
Soft Mounting, MAXUM	G3-81
Specifications	
Combination TIGEAR	G5-5
MAXUM	G3-5

