



2011

BALDOR•DODGE®  
MOTORIZED TORQUE-ARM™ II  
REDUCERS



**BALDOR**®  
A MEMBER OF THE ABB GROUP



## Accessories

MTA uses standard TA II accessories

### Bushings – Standard Twin Taper

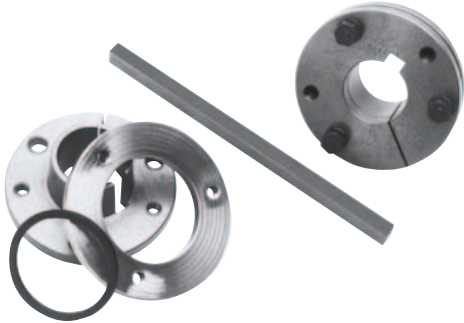

### Short Shaft Twin Taper

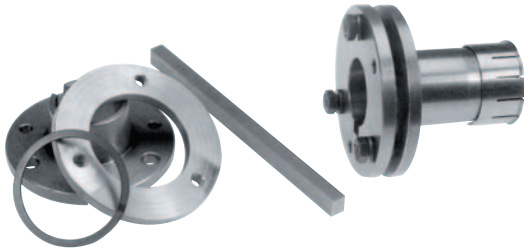

### Bushing Covers

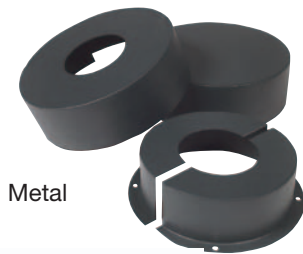

Metal



ABS Plastic

### Backstop

MTA Reducers require the next higher size TA II Backstop as noted in accessory pages



### Screw Conveyor Adapter with adjustable packing kit



### Driveshaft



### Tie Rod





**Determining Service Class** Class I - 1.0 service factor, Class II - 1.4 service factor, Class III - 2.0 service factor

Application	Class Numbers	
	3 to 10 Hrs per Day	Over 10 Hrs per Day
<b>Agitators (Mixers)</b>	–	–
Pure Liquids	I	II
Liquids and Solids	II	II
Liquids-Variable Density	II	II
<b>Blowers</b>	–	–
Centrifugal	I	II
Lobe	II	II
Vane	II	II
<b>Brewing and Distilling</b>	–	–
Bottling Machinery	I	II
Brew Kettles-Continuous Duty	II	II
Cookers-Continuous Duty	II	II
Mash Tubs-Continuous Duty	II	II
Scale Hopper-Frequent Starts	II	II
<b>Can Filling Machines</b>	I	II
<b>Car Dumpers</b>	III	III
<b>Car Pullers</b>	II	II
<b>Clarifiers</b>	I	II
<b>Classifiers</b>	II	II
<b>Clay Working Machinery</b>	–	–
Brick Press	III	III
Briquette Machine	III	III
Pug Mill	II	II
<b>Compactors</b>	★	★
<b>Compressors</b>	–	–
Centrifugal	I	II
Lobe	II	II
Reciprocating, Multi-Cylinder	II	III
Reciprocating, Single-Cylinder	III	III
<b>Conveyors-General Purpose</b>	(Includes Apron, Assembly, Belt, Bucket, Chain, Flight, Oven and Screw)	
Uniformly Loaded or Fed	I	II
Heavy Duty-Not Uniformly Fed	II	II
Severe Duty-Reciprocating or Shaker	III	III
<b>Cranes</b>	★	★
<b>Crusher</b>	–	–
Stone or Ore	III	III
<b>Dredges</b>	–	–
Cable Reels	II	II
Conveyors	II	II
Cutter Head Drives	III	III
Pumps	III	III
Screen Drives	III	III
Stackers	II	II
Winches	II	II

Application	Class Numbers	
	3 to 10 Hrs per Day	Over 10 Hrs per Day
<b>Elevators</b>	–	–
Bucket	II	II
Centrifugal Discharge	I	II
Escalators	I	II
Freight	II	II
Gravity Discharge	I	II
<b>Extruders</b>	–	–
General	II	II
Plastics	–	–
Variable Speed Drive	III	III
Fixed Speed Drive	III	III
Rubber	–	–
Continuous Screw Operation	III	III
Intermittent Screw Operation	III	III
<b>Fans</b>	–	–
Centrifugal	I	II
Forced Draft	II	II
Induced Draft	II	II
Industrial & Mine	II	II
<b>Feeders</b>	–	–
Apron, Belt	II	II
Disc	I	II
Reciprocating	III	III
Screw	II	II
<b>Food Industry</b>	–	–
Cereal Cooker	I	II
Dough Mixer	II	II
Meat Grinders	II	II
Slicers	II	II
<b>Generators and Exciters</b>	II	II
<b>Hammer Mills</b>	III	III
<b>Hoists</b>	★	★
<b>Laundry Tumblers</b>	II	II
<b>Laundry Washers</b>	II	III



**Determining Service Class Class I - 1.0 service factor, Class II - 1.4 service factor, Class III - 2.0 service factor**

Application	Class Numbers	
	3 to 10 Hrs per Day	Over 10 Hrs per Day
<b>Lumber Industry</b>	–	–
Barkers	–	–
Spindle Feed	II	II
Main Drive	III	III
Conveyors	–	–
Burner	II	II
Main or Heavy Duty	II	II
Main Log	III	III
Re-saw, Merry-Go-Round	II	II
Transfer	II	II
Slab	III	III
Chains	–	–
Floor	II	II
Green	II	III
Cut-Off Saws	–	–
Chain	II	III
Drag	II	III
Debarking Drums	III	III
Feeds	–	–
Edger	II	II
Gang	III	III
Trimmer	II	II
Log Deck	III	III
Log Hauls-Incline-Well Type	III	III
Log Tuning Devices	III	III
Planer Feed	II	II
Planer Tilting Hoists	II	II
Rolls-Live-off brg.-Roll Cases	III	III
Sorting Table	II	II
Triple Hoist	II	II
Transfers	–	–
Chain	II	III
Craneway	II	III
Tray Drives	II	II
Veneer Lathe Drives	II	II
<b>Metal Mills</b>	–	–
Draw bench Carriage and Main Drive	II	II
Runout Table	–	–
Non-Reversing	–	–
Group Drives	II	II
Individual Drives	III	III
Reversing	III	III
Slab Pushers	II	II
Shears	III	III

Application	Class Numbers	
	3 to 10 Hrs per Day	Over 10 Hrs per Day
Wire Drawing	II	II
Wire Winding Machine	II	II
<b>Metal Strip Processing Machinery</b>	–	–
Bridles	II	II
Coilers & Uncoilers	I	II
Edge Trimmers	II	II
Flatteners	II	II
Loopers (Accumulators)	I	I
Pinch Rolls	II	II
Scrap Choppers	II	II
Shears	III	III
Slitters	II	II
<b>Mills, Rotary Type</b>	–	–
Ball & Rod	–	–
Spur Ring Gear	III	III
Helical Ring Gear	II	II
Direct Connected	III	III
Cement Kilns	II	II
Dryers & Coolers	II	II
<b>Mixers, Cement, Paper Mills</b>	–	–
Agitator (Mixer)	II	II
Agitator for Pure Liquors	II	II
Barking Drums	III	III
Barkers-Mechanical	III	III
Beater	II	II
Breaker Stack	II	II
Chipper	III	III
Chip Feeder	II	II
Coating Rolls	II	II
Conveyors	–	–
Chip, Bark, Chemical	II	II
Log (including Slab)	III	III
Couch Rolls	II	II
Cutter	III	III
Cylinder Molds	II	II
Embosses	II	II
Extruder	II	II
Fourdrinier Rolls (includes Lump breaker, dandy roll, wire turning, and return rolls)	II	II
Jordan	II	II
Kiln Drive	II	II
Mt. Hope Roll	II	II
Paper Rolls	II	II
Platter	II	II



**Determining Service Class** Class I - 1.0 service factor, Class II - 1.4 service factor, Class III - 2.0 service factor

Application	Class Numbers	
	3 to 10 Hrs per Day	Over 10 Hrs per Day
<b>Mixers, Cement, Paper Mills (cont)</b>	—	—
Presses-Felt & Suction	II	II
Pulper	III	III
Pumps-Vacuum	II	II
Reel (Surface Type)	II	II
Screens	—	—
Chip	II	II
Rotary	II	II
Vibrating	III	III
Size Press	II	II
Thickener (AC Motor)	II	II
(DC Motor)	II	II
Washer (AC Motor)	II	II
(DC Motor)	II	II
Wind and Unwind Stand	I	I
Winders (Surface Type)	II	II
<b>Plastics Industry-Secondary Processing</b>	—	—
Blow Molders	II	II
Coating	II	II
Film	II	II
Pipe	II	II
Pre-Plasticizers	II	II
Rods	II	II
Sheet	II	II
Tubing	II	II
<b>Pullers-Barge Haul Pumps</b>	II	II
Centrifugal	I	II
Proportioning	II	II
Reciprocating	—	—
Single Acting, 3 or more cylinders	II	II
Double Acting, 2 or more cylinders	II	II
Rotary	—	—
Gear Type	I	II
Lobe	I	II
Vane	I	II
<b>Rubber and Plastics Industry</b>	—	—
Intensive Internal Mixers	—	—
Batch Mixers	III	III
Continuous Mixers	II	II
Mixing Mill	—	—
2 smooth rolls	II	II
1 or 2 corrugated rolls	III	III
Batch Drop Mill - 2 smooth rolls	II	II

Application	Class Numbers	
	3 to 10 Hrs per Day	Over 10 Hrs per Day
Cracker Warmer - 2 roll, 1 corrugated roll	III	III
Cracker-2 corrugated rolls	III	III
Holding, Feed & Blend Mill-2 rolls	II	II
Refiner-2 rolls	II	II
Calenders	II	II
<b>Sand Muller</b>	II	II
<b>Sewage Disposal Equipment</b>	—	—
Bar Screens	II	II
Chemical Feeders	II	II
Dewatering Screens	II	II
Scum Breakers	II	II
Slow or Rapid Mixers	II	II
Sludge Collectors	II	II
Thickener	II	II
Vacuum Filters	II	II
<b>Screens</b>	—	—
Air Washing	I	II
Rotary-Stone or Gravel	II	II
Traveling Water Intake	I	I
<b>Screw Conveyors</b>	—	—
Uniformly Loaded or Fed	I	II
Heavy Duty	II	II
<b>Sugar Industry</b>	—	—
Beet Slicer	III	III
Cane knives	II	II
Crushers	II	II
Mills (low speed end)	III	III
<b>Textile Industry</b>	—	—
Batchers	II	II
Calenders	II	II
Cards	II	II
Dry Cans	II	II
Dyeing Machinery	II	II
Looms	II	II
Mangles	II	II
Nappers	II	II
Pads	II	II
Stashers	II	II
Soapers	II	II
Spinners	II	II
Tenter Frames	II	II
Washers	II	II
Winders	II	II



**MTA2115H, MTA4207H, & MTA6307H Nomenclature and Descriptions**

**MTA C-Face Reducer Nomenclature  
M4H74T21C TORQUE-ARM REDUCER ONLY**

**M** - Motorized Torque-Arm  
**4** - Case Size, **H** - Heavy Duty,  
**74** - NominalRatio, **T** - Tapered Bore  
**21** - 210 - Motor Frame, **C** - Nema C-Face,



Part Number	Part Number	Part Number
M2H30T18C	M4H41T21C	M6H52T25C
M2H32T18C	M4H44T21C	M6H59T25C
M2H36T18C	M4H49T21C	M6H67T25C
M2H39T18C	M4H52T21C	M6H79T25C
M2H44T18C	M4H61T21C	M6H34T28C
M2H47T18C	M4H66T21C	M6H39T28C
M2H51T18C	M4H74T21C	M6H45T28C
M2H58T18C	M4H18T25C	M6H50T28C
M2H66T18C	M4H22T25C	M6H52T28C
M2H71T18C	M4H26T25C	M6H59T28C
M2H77T18C	M4H30T25C	M6H67T28C
M2H18T21C	M4H34T25C	M6H67T28TSC
M2H21T21C	M4H41T25C	M6H79T28TSC
M2H25T21C	M4H44T25C	M6H22T32C
M2H30T21C	M4H49T25C	M6H24T32C
M2H32T21C	M4H52T25C	M6H29T32C
M2H36T21C	M4H61T25C	M6H34T32C
M2H39T21C	M4H66T25C	M6H39T32C
M2H44T21C	M4H74T25C	M6H39T32TSC
M2H47T21C	M4H18T28C	M6H45T32C
M2H51T21C	M4H22T28C	M6H45T32TSC
M2H58T21C	M4H22T28TSC	M6H50T32C
M2H66T21C	M4H26T28TSC	M6H50T32TSC
M2H71T21C	M4H30T28TSC	M6H52T32C
M2H77T21C	M4H34T28TSC	M6H52T32TSC
M2H18T25C	M4H41T28TSC	M6H59T32TSC
M2H21T25C	M4H44T28TSC	M6H67T32TSC
M2H25T25C	M4H49T28TSC	M6H79T32TSC
M2H30T25C	M4H52T28TSC	M6H19T36C
M2H32T25C	M4H18T32TSC	M6H19T36TSC
M2H36T25C	M4H22T32TSC	M6H22T36C
-	M4H26T32TSC	M6H22T36TSC
-	M4H30T32TSC	M6H24T36C
-	M4H34T32TSC	M6H24T36TSC
-	-	M6H29T36C
-	-	M6H29T36TSC
-	-	M6H34T36C
-	-	M6H34T36TSC
-	-	M6H39T36C
-	-	M6H39T36TSC
-	-	M6H45T36C
-	-	M6H45T36TSC
-	-	M6H50T36C
-	-	M6H50T36TSC
-	-	M6H52T36C
-	-	M6H52T36TSC

Note: Use EZ-Selection Charts and verify REQUIRED base C-Face Motor Speed before ordering  
 Part number includes Reducer, C-Face Adapter, and 3 Piece Coupling





**MTA2115H, MTA4207H, & MTA6307H Nomenclature and Descriptions**

**MTA C-Face Gearmotor Nomenclature**

**M4H74T21C1018 TORQUE-ARM REDUCER with MOTOR**

**M** - Motorized Torque-Arm  
**4** - Case Size, **H** - Heavy Duty,  
**74** - NominalRatio, **T** - Tapered Bore  
**21** - 210 - Motor Frame, **C** - Nema C-Face,  
**10** - 10HP Motor, **18** - 1800 Rpm Motor Speed

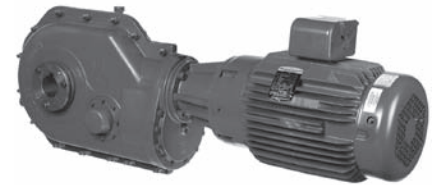

Part Number	Part Number	Part Number
M2H30T18C518	M4H61T21C718	M6H52T25C2018
M2H32T18C518	M4H61T21C1018	M6H59T25C2018
M2H36T18C518	M4H66T21C1018	M6H67T25C1518
M2H39T18C518	M4H66T21C718	M6H79T25C1518
M2H44T18C518	M4H74T21C1018	M6H79T25C2018
M2H47T18C318	M4H74T21C1036	M6H34T28C3018
M2H51T18C318	M4H74T21C718	M6H39T28C3018
M2H51T18C518	M4H18T25C2018	M6H45T28C2518
M2H58T18C518	M4H22T25C2018	M6H45T28C3018
M2H66T18C318	M4H26T25C2018	M6H50T28C2518
M2H66T18C536	M4H30T25C1518	M6H50T28C3018
M2H71T18C318	M4H30T25C2018	M6H52T28C2518
M2H77T18C318	M4H34T25C1518	M6H52T28C3018
M2H18T21C1018	M4H34T25C2018	M6H59T28C3018
M2H21T21C718	M4H41T25C1518	M6H67T28C2518
M2H21T21C1018	M4H41T25C2036	M6H67T28TSC3036
M2H25T21C718	M4H44T25C1518	M6H79T28TSC3036
M2H25T21C1018	M4H44T25C2036	M6H22T32C5018
M2H30T21C1018	M4H49T25C1518	M6H24T32C5018
M2H32T21C718	M4H49T25C2036	M6H29T32C4018
M2H36T21C718	M4H52T25C1518	M6H29T32C5018
M2H39T21C718	M4H52T25C1536	M6H34T32C5018
M2H39T21C1036	M4H61T25C1536	M6H39T32C4018
M2H44T21C718	M4H61T25C2036	M6H39T32TSC5036
M2H44T21C1036	M4H66T25C1536	M6H45T32TSC5036
M2H44T21C736	M4H66T25C2036	M6H50T32TSC4036
M2H47T21C736	M4H74T25C2036	M6H52T32TSC4036
M2H47T21C1036	M4H18T28C2518	M6H59T32TSC4036
M2H51T21C736	M4H18T28C3018	M6H59T32TSC5036
M2H51T21C1036	M4H22T28C3018	M6H67T32TSC5036
M2H66T21C736	M4H22T28TSC3036	M6H79T32TSC4036
M2H18T25C1518	M4H26T28C2518	-
M2H18T25C2018	M4H26T28TSC3036	-
M2H18T25C1536	M4H30T28TSC3036	-
M2H18T25C2036	M4H34T28TSC2536	-
M2H21T25C2036	M4H34T28TSC3036	-
M2H25T25C1536	M4H41T28TSC3036	-
M2H30T25C1536	M4H44T28TSC3036	-
M2H32T25C1536	M4H49T28TSC2536	-
M2H36T25C1536	M4H52T28TSC2536	-
-	M4H18T32TSC4036	-
M4H41T21C1018	M4H18T32TSC5036	-
M4H44T21C1018	M4H22T32TSC5036	-
M4H49T21C1018	M4H26T32TSC4036	-
M4H52T21C1018	M4H30T32TSC4036	-
	M4H34T32TSC4036	-

Note: Use EZ-Selection Charts and verify REQUIRED base C-Face Motor Speed before ordering  
 Part number includes Reducer assembled to Baldor C-Face Motor



**MTA Engineering Information**  
**MTA2 Horsepower and Torque Ratings**

**MTA2115**

Ratio	Mtr speed	Nema180TC		Nema210TC		Nema250TC		Nema280TC / 280TSC		Nema320TC / 320TSC	
		1750	3450	1750	3450	1750	3450	1750	3450	1750	3450
76.96	Output rpm	23	45	–	45	–	–	–	–	–	–
	Class I catalog HP	4.4	8.4	–	8.4	–	–	–	–	–	–
	Class I torque in-lbs	11155	10700	–	10700	–	–	–	–	–	–
	Part Number	M2H77T18C	M2H77T18C	–	M2H77T21C	–	–	–	–	–	–
71.18	Output rpm	25	48	–	48	–	–	–	–	–	–
	Class I catalog HP	4.8	8.9	–	8.9	–	–	–	–	–	–
	Class I torque in-lbs	11155	10645	–	10645	–	–	–	–	–	–
	Part Number	M2H71T18C	M2H71T18C	–	M2H71T21C	–	–	–	–	–	–
66.07	Output rpm	26	52	–	52	–	–	–	–	–	–
	Class I catalog HP	5.0	9.5	–	9.5	–	–	–	–	–	–
	Class I torque in-lbs	11155	10525	–	10525	–	–	–	–	–	–
	Part Number	M2H66T18C	M2H66T18C	–	M2H61T21C	–	–	–	–	–	–
58.29	Output rpm	30	59	–	59	–	–	–	–	–	–
	Class I catalog HP	5.8	10.5	–	10.5	–	–	–	–	–	–
	Class I torque in-lbs	11155	10300	–	10300	–	–	–	–	–	–
	Part Number	M2H58T18C	M2H58T18C	–	M2H58T21C	–	–	–	–	–	–
51.31	Output rpm	34	67	–	67	–	–	–	–	–	–
	Class I catalog HP	6.5	11.7	–	11.7	–	–	–	–	–	–
	Class I torque in-lbs	11050	10145	–	10145	–	–	–	–	–	–
	Part Number	M2H51T18C	M2H51T18C	–	M2H51T21C	–	–	–	–	–	–
47.45	Output rpm	37	73	–	73	–	–	–	–	–	–
	Class I catalog HP	7.0	12.5	–	12.5	–	–	–	–	–	–
	Class I torque in-lbs	10950	9874	–	9874	–	–	–	–	–	–
	Part Number	M2H47T18C	M2H47T18C	–	M2H47T21C	–	–	–	–	–	–
44.05	Output rpm	40	78	40	78	–	–	–	–	–	–
	Class I catalog HP	7.6	13.1	7.6	13.1	–	–	–	–	–	–
	Class I torque in-lbs	10888	9639	10888	9639	–	–	–	–	–	–
	Part Number	M2H44T18C	M2H44T18C	M2H44T21C	M2H44T21C	–	–	–	–	–	–
38.86	Output rpm	45	89	45	89	–	–	–	–	–	–
	Class I catalog HP	8.4	14.6	8.4	14.6	–	–	–	–	–	–
	Class I torque in-lbs	10700	9440	10700	9440	–	–	–	–	–	–
	Part Number	M2H39T18C	M2H39T18C	M2H39T21C	M2H39T21C	–	–	–	–	–	–
35.88	Output rpm	49	96	49	96	–	96	–	–	–	–
	Class I catalog HP	9.0	15.4	9.0	15.4	–	15.4	–	–	–	–
	Class I torque in-lbs	10600	9210	10600	9210	–	9210	–	–	–	–
	Part Number	M2H36T18C	M2H36T18C	M2H36T21C	M2H36T21C	–	M2H36T25C	–	–	–	–
32.15	Output rpm	54	107	54	107	–	107	–	–	–	–
	Class I catalog HP	9.8	16.6	9.8	16.6	–	16.6	–	–	–	–
	Class I torque in-lbs	10459	8920	10459	8920	–	8920	–	–	–	–
	Part Number	M2H32T18C	M2H32T18C	M2H32T21C	M2H32T21C	–	M2H32T25C	–	–	–	–
29.64	Output rpm	59	116	59	116	–	116	–	–	–	–
	Class I catalog HP	10.5	17.6	10.5	17.6	–	17.6	–	–	–	–
	Class I torque in-lbs	10300	8699	10300	8699	–	8699	–	–	–	–
	Part Number	M2H30T18C	M2H30T18C	M2H30T21C	M2H30T21C	–	M2H30T25C	–	–	–	–
24.87	Output rpm	70	139	70	139	–	139	–	–	–	–
	Class I catalog HP	12.1	19.8	12.1	19.8	–	19.8	–	–	–	–
	Class I torque in-lbs	9961	8170	9961	8170	–	8170	–	–	–	–
	Part Number	M2H25T18C	M2H25T18C	M2H25T21C	M2H25T21C	–	M2H25T25C	–	–	–	–
21.22	Output rpm	82	163	82	–	–	163	–	–	–	–
	Class I catalog HP	13.7	22.4	13.7	–	–	22.4	–	–	–	–
	Class I torque in-lbs	9594	7900	9594	–	–	7900	–	–	–	–
	Part Number	M2H21T18C	M2H21T18C	M2H21T21C	–	–	M2H21T25C	–	–	–	–
17.68	Output rpm	99	195	99	–	99	195	–	–	–	–
	Class I catalog HP	15.7	25.6	15.7	–	15.7	25.6	–	–	–	–
	Class I torque in-lbs	9100	7540	9100	–	9100	7540	–	–	–	–
	Part Number	M2H18T18C	M2H18T18C	M2H18T21C	–	M2H18T25C	M2H18T25C	–	–	–	–





**MTA Engineering Information**  
**MTA4 Horsepower and Torque Ratings**

**MTA4207**

Ratio	Mtr speed	Nema180TC		Nema210TC		Nema250TC		Nema280TC / 280TSC		Nema320TSC	
		1750	3450	1750	3450	1750	3450	1750	3450	1750	3450
73.57	Output rpm	24	47	24	47	–	47	–	–	–	–
	Class I catalog HP	11.5	20.3	11.5	20.3	–	20.3	–	–	–	–
	Class I torque in-lbs	27555	25341	27555	25341	–	25341	–	–	–	–
	Part Number	M4H74T18C	M4H74T18C	M4H74T21C	M4H74T21C	–	M4H74T25C	–	–	–	–
66.17	Output rpm	26	52	26	52	–	52	–	–	–	–
	Class I catalog HP	12.4	22.5	12.4	22.5	–	22.5	–	–	–	–
	Class I torque in-lbs	27307	24907	27307	24907	–	24907	–	–	–	–
	Part Number	M4H66T18C	M4H66T18C	M4H66T21C	M4H66T21C	–	M4H66T25C	–	–	–	–
61.04	Output rpm	29	57	29	57	–	57	–	–	–	–
	Class I catalog HP	13.2	24.0	13.2	24.0	–	24.0	–	–	–	–
	Class I torque in-lbs	27095	24635	27095	24635	–	24635	–	–	–	–
	Part Number	M4H61T18C	M4H61T18C	M4H61T21C	M4H61T21C	–	M4H61T25C	–	–	–	–
51.72	Output rpm	34	67	34	67	34	67	–	67	–	–
	Class I catalog HP	15.6	27.6	15.6	27.6	15.6	27.6	–	27.6	–	–
	Class I torque in-lbs	26421	24049	26421	24049	26421	24049	–	24049	–	–
	Part Number	M4H52T18C	M4H52T18C	M4H52T21C	M4H52T21C	M4H52T25C	M4H52T25C	–	M4H52T28TSC	–	–
49.04	Output rpm	36	70	36	70	36	70	–	70	–	–
	Class I catalog HP	16.4	29.0	16.4	29.0	16.4	29.0	–	29.0	–	–
	Class I torque in-lbs	26217	23849	26217	23849	26217	23849	–	23849	–	–
	Part Number	M4H49T18C	M4H49T18C	M4H49T21C	M4H49T21C	M4H49T25C	M4H49T25C	–	M4H49T28TSC	–	–
44.11	Output rpm	40	78	40	78	40	78	–	78	–	–
	Class I catalog HP	18.0	31.8	18.0	31.8	18.0	31.8	–	31.8	–	–
	Class I torque in-lbs	25870	23460	25870	23460	25870	23460	–	23460	–	–
	Part Number	M4H44T18C	M4H44T18C	M4H44T21C	M4H44T21C	M4H44T25C	M4H44T25C	–	M4H44T28TSC	–	–
40.70	Output rpm	43	85	43	85	43	85	–	85	–	–
	Class I catalog HP	19.0	33.9	19.0	33.9	19.0	33.9	–	33.9	–	–
	Class I torque in-lbs	25600	23198	25600	23198	25600	23198	–	23198	–	–
	Part Number	M4H41T18C	M4H41T18C	M4H41T21C	M4H41T21C	M4H41T25C	M4H41T25C	–	M4H41T28TSC	–	–
34.48	Output rpm	51	100	51	100	51	100	–	100	–	100
	Class I catalog HP	21.8	39.3	21.8	39.3	21.8	39.3	–	39.3	–	39.3
	Class I torque in-lbs	25059	22592	25059	22592	25059	22592	–	22592	–	22592
	Part Number	M4H34T18C	M4H34T18C	M4H34T21C	M4H34T21C	M4H34T25C	M4H34T25C	–	M4H34T28TSC	–	M4H34T32TSC
30.05	Output rpm	58	115	58	115	58	115	–	115	–	115
	Class I catalog HP	24.7	42.8	24.7	42.8	24.7	42.8	–	42.8	–	42.8
	Class I torque in-lbs	24514	21577	24514	21577	24514	21577	–	21577	–	21577
	Part Number	M4H30T18C	M4H30T18C	M4H30T21C	M4H30T21C	M4H30T25C	M4H30T25C	–	M4H30T28TSC	–	M4H30T32TSC
25.57	Output rpm	68	135	68	135	68	135	68	135	–	135
	Class I catalog HP	28.3	47.4	28.3	47.4	28.3	47.4	28.3	47.4	–	47.4
	Class I torque in-lbs	23946	20336	23946	20336	23946	20336	23946	20336	–	20336
	Part Number	M4H26T18C	M4H26T18C	M4H26T21C	M4H26T21C	M4H26T25C	M4H26T25C	M4H26T28C	M4H26T28TSC	–	M4H26T32TSC
21.82	Output rpm	80	158	80	158	80	158	80	158	–	158
	Class I catalog HP	32.5	52.9	32.5	52.9	32.5	52.9	32.5	52.9	–	52.9
	Class I torque in-lbs	23375	19268	23375	19268	23375	19268	23375	19268	–	19268
	Part Number	M4H22T18C	M4H22T18C	M4H22T21C	M4H22T21C	M4H22T25C	M4H22T25C	M4H22T28C	M4H22T28TSC	–	M4H22T32TSC
17.89	Output rpm	98	193	98	193	98	193	98	193	–	193
	Class I catalog HP	38.6	59.3	38.6	59.3	38.6	59.3	38.6	59.3	–	59.3
	Class I torque in-lbs	22660	17747	22660	17747	22660	17747	22660	17747	–	17747
	Part Number	M4H18T18C	M4H18T18C	M4H18T21C	M4H18T21C	M4H18T25C	M4H18T25C	M4H18T28C	M4H18T28TSC	–	M4H18T32TSC



**MTA Engineering Information**  
**MTA6 Horsepower and Torque Ratings**

**MTA6307**

Ratio	Mtr speed	Nema210TC		Nema250TC		Nema280TC / 280TSC		Nema320TC / 320TSC		Nema360TC / 360TSC	
		1750	3450	1750	3450	1750	3450	1750	3450	1750	3450
78.53	Output rpm	22	44	22	44	22	44	-	44	-	-
	Class I catalog HP	23.6	44.7	23.6	44.7	23.6	44.7	-	44.7	-	-
	Class I torque in-lbs	61675	58420	61675	58420	61675	58420	-	58420	-	-
	Part Number	M6H79T21C	M6H79T21C	M6H79T25C	M6H79T25C	M6H79T28C	M6H79T28TSC	-	M6H79T32TSC	-	-
66.92	Output rpm	26	52	26	52	26	52	-	52	-	-
	Class I catalog HP	27.5	52.1	27.5	52.1	27.5	52.1	-	52.1	-	-
	Class I torque in-lbs	60887	57598	60887	57598	60887	57598	-	57598	-	-
	Part Number	M6H67T21C	M6H67T21C	M6H67T25C	M6H67T25C	M6H67T28C	M6H67T28TSC	-	M6H67T32TSC	-	-
59.05	Output rpm	30	58	30	58	30	58	-	58	-	-
	Class I catalog HP	31.5	57.5	31.5	57.5	31.5	57.5	-	57.5	-	-
	Class I torque in-lbs	60309	57038	60309	57038	60309	57038	-	57038	-	-
	Part Number	M6H59T21C	M6H59T21C	M6H59T25C	M6H59T25C	M6H59T28C	M6H59T28TSC	-	M6H59T32TSC	-	-
52.35	Output rpm	33	66	33	66	33	66	-	66	-	66
	Class I catalog HP	34.3	64.7	34.3	64.7	34.3	64.7	-	64.7	-	64.7
	Class I torque in-lbs	59800	56359	59800	56359	59800	56359	-	56359	-	56359
	Part Number	M6H52T21C	M6H52T21C	M6H52T25C	M6H52T25C	M6H52T28C	M6H52T28TSC	-	M6H52T32TSC	-	M6H52T36TSC
50.26	Output rpm	35	69	35	69	35	69	-	69	-	69
	Class I catalog HP	36.2	67.3	36.2	67.3	36.2	67.3	-	67.3	-	67.3
	Class I torque in-lbs	59500	56100	59500	56100	59500	56100	-	56100	-	56100
	Part Number	M6H50T21C	M6H50T21C	M6H50T25C	M6H50T25C	M6H50T28C	M6H50T28TSC	-	M6H50T32TSC	-	M6H50T36TSC
44.61	Output rpm	39	77	39	77	39	77	-	77	-	74.4
	Class I catalog HP	39.8	74.4	39.8	74.4	39.8	74.4	-	74.4	-	74.40
	Class I torque in-lbs	59050	55500	59050	55500	59050	55500	-	55500	-	55500
	Part Number	M6H45T21C	M6H45T21C	M6H45T25C	M6H45T25C	M6H45T28C	M6H45T28TSC	-	M6H45T32TSC	-	M6H45T36TSC
39.37	Output rpm	44	88	44	88	44	88	44	88	-	88
	Class I catalog HP	44.7	83.0	44.7	83.0	44.7	83.0	44.7	83.0	-	83.0
	Class I torque in-lbs	58420	54219	58420	54219	58420	54219	58420	54219	-	54219
	Part Number	M6H39T21C	M6H39T21C	M6H39T25C	M6H39T25C	M6H39T28C	M6H39T28TSC	M6H39T32C	M6H39T32TSC	-	M6H39T36TSC
33.51	Output rpm	52	103	52	103	52	103	52	103	-	103
	Class I catalog HP	52.1	94.2	52.1	94.2	52.1	94.2	52.1	94.2	-	94.2
	Class I torque in-lbs	57598	52600	57598	52600	57598	52600	57598	52600	-	52600
	Part Number	M6H34T21C	M6H34T21C	M6H34T25C	M6H34T25C	M6H34T28C	M6H34T28TSC	M6H34T32C	M6H34T32TSC	-	M6H34T36TSC
29.03	Output rpm	60	119	60	119	60	119	60	119	-	119
	Class I catalog HP	59.4	106.0	59.4	106.0	59.4	106.0	59.4	106.0	-	106.0
	Class I torque in-lbs	56877	51200	56877	51200	56877	51200	56877	51200	-	51200
	Part Number	M6H29T21C	M6H29T21C	M6H29T25C	M6H29T25C	M6H29T28C	M6H29T28TSC	M6H29T32C	M6H29T32TSC	-	M6H29T36TSC
24.43	Output rpm	72	141	72	141	72	141	72	141	72	141
	Class I catalog HP	69.8	119.8	69.8	119.8	69.8	119.8	69.8	119.8	69.8	119.8
	Class I torque in-lbs	55995	48900	55995	48900	55995	48900	55995	48900	55995	48900
	Part Number	M6H24T21C	M6H24T21C	M6H24T25C	M6H24T25C	M6H24T28C	M6H24T28TSC	M6H24T32C	M6H24T32TSC	M6H24T36C	M6H24T36TSC
22.04	Output rpm	79	157	79	157	79	157	79	157	79	157
	Class I catalog HP	76.0	129.0	76.0	129.0	76.0	129.0	76.0	129.0	76.0	129.0
	Class I torque in-lbs	55400	47290	55400	47290	55400	47290	55400	47290	55400	47290
	Part Number	M6H22T21C	M6H22T21C	M6H22T25C	M6H22T25C	M6H22T28C	M6H22T28TSC	M6H22T32C	M6H22T32TSC	M6H22T36C	M6H22T36TSC
18.95	Output rpm	92	182	92	182	92	182	92	182	92	182
	Class I catalog HP	86.0	140.8	86.0	140.8	86.0	140.8	86.0	140.8	86.0	140.8
	Class I torque in-lbs	53743	44484	53743	44484	53743	44484	53743	44484	53743	44484
	Part Number	M6H19T21C	M6H19T21C	M6H19T25C	M6H19T25C	M6H19T28C	M6H19T28TSC	M6H19T32C	M6H19T32TSC	M6H19T36C	M6H19T36TSC



**MTA EZ Selection Tables**

**Class 1, 1.0 Service Factor**

**MTA2115H CLASS 1**

Output rpm	Ratio	Class 1 Motor HP	Motor speed	Part Number	C-Face GearMotor Part Number	Service factor
23	76.96	3	1750	M2H77T18C	M2H77T18C318	1.47
25	71.18	3	1750	M2H71T18C	M2H71T18C318	1.60
26	66.07	5	1750	M2H66T18C	M2H66T18C518	1.01
30	58.29	5	1750	M2H58T18C	M2H58T18C518	1.16
34	51.31	5	1750	M2H51T18C	M2H51T18C518	1.29
37	47.45	5	1750	M2H47T18C	M2H47T18C518	1.40
40	44.05	7.5	1750	M2H44T21C	M2H44T21C718	1.01
45	38.86	7.5	1750	M2H39T21C	M2H39T21C718	1.12
49	35.88	7.5	1750	M2H36T21C	M2H36T21C718	1.20
52	66.07	7.5	3450	M2H66T21C	M2H66T21C736	1.27
54	32.15	7.5	1750	M2H32T21C	M2H32T21C718	1.31
59	29.64	10	1750	M2H30T21C	M2H30T21C1018	1.05
67	51.31	10	3450	M2H51T21C	M2H51T21C1036	1.17
70	24.87	10	1750	M2H25T21C	M2H25T21C1018	1.21
73	47.45	10	3450	M2H47T21C	M2H47T21C1036	1.25
78	44.05	10	3450	M2H44T21C	M2H44T21C1036	1.31
82	21.22	10	1750	M2H21T21C	M2H21T21C1018	1.37
89	38.86	10	3450	M2H39T21C	M2H39T21C1036	1.46
96	35.88	15	3450	M2H36T25C	M2H36T25C1536	1.03
99	17.68	15	1750	M2H18T25C	M2H18T25C1518	1.05
107	32.15	15	3450	M2H32T25C	M2H32T25C1536	1.11
116	29.64	15	3450	M2H30T25C	M2H30T25C1536	1.17
139	24.87	15	3450	M2H25T25C	M2H25T25C1536	1.32
163	21.22	20*	3450	M2H21T25C	M2H21T25C2036	1.12
195	17.68	20*	3450	M2H18T25C	M2H18T25C2036	1.28

\* Consult Dodge Engineering for thermal considerations of application

**MTA EZ Selection Tables**

**Class 2, 1.4 Service Factor**

**MTA2115H CLASS 2**

Output rpm	Ratio	Class 2 Mtr HP	Mtr speed	Part Number	C-Face GearMotor Part Number	Service factor
23	76.96	3	1750	M2H77T18C	M2H77T18C318	1.47
25	71.18	3	1750	M2H71T18C	M2H71T18C318	1.60
26	66.07	3	1750	M2H66T18C	M2H66T18C318	1.68
30	58.29	3	1750	M2H58T18C	M2H58T18C318	1.94
34	51.31	3	1750	M2H51T18C	M2H51T18C318	2.16
37	47.45	3	1750	M2H47T18C	M2H47T18C318	2.33
40	44.05	5	1750	M2H44T18C	M2H44T18C518	1.51
45	38.86	5	1750	M2H39T18C	M2H39T18C518	1.68
49	35.88	5	1750	M2H36T18C	M2H36T18C518	1.80
52	66.07	5	3450	M2H66T18C	M2H66T18C536	1.90
54	32.15	5	1750	M2H32T18C	M2H32T18C518	1.96
59	29.64	5	1750	M2H30T18C	M2H30T18C518	2.11
67	51.31	7.5	3450	M2H51T21C	M2H51T21C736	1.56
70	24.87	7.5	1750	M2H25T21C	M2H25T21C718	1.62
73	47.45	7.5	3450	M2H47T21C	M2H47T21C736	1.66
78	44.05	7.5	3450	M2H44T21C	M2H44T21C736	1.74
82	21.22	7.5	1750	M2H21T21C	M2H21T21C718	1.82
89	38.86	10	3450	M2H39T21C	M2H39T21C1036	1.46
96	35.88	10	3450	M2H36T21C	M2H36T21C1036	1.54
99	17.68	10	1750	M2H18T21C	M2H18T21C1018	1.57
107	32.15	10	3450	M2H32T21C	M2H32T21C1036	1.66
116	29.64	10	3450	M2H30T21C	M2H30T21C1036	1.76
139	24.87	10	3450	M2H25T21C	M2H25T21C1036	1.98
163	21.22	15	3450	M2H21T25C	M2H21T25C1536	1.49
195	17.68	15	3450	M2H18T25C	M2H18T25C1536	1.71



**MTA EZ Selection Tables**  
Class 1, 1.0 Service Factor

**MTA4207H CLASS 1**

Output rpm	Ratio	Class 1 Mtr HP	Mtr speed	Reducer Part Number	C-Face GearMotor Part Number	Service factor
24	73.57	10	1750	M4H74T21C	M4H74T21C1018	1.15
26	66.17	10	1750	M4H66T21C	M4H66T21C1018	1.24
29	61.04	10	1750	M4H61T21C	M4H61T21C1018	1.32
34	51.72	15	1750	M4H52T25C	M4H52T25C1518	1.04
36	49.04	15	1750	M4H49T25C	M4H49T25C1518	1.09
40	44.11	15	1750	M4H44T25C	M4H44T25C1518	1.20
43	40.70	15	1750	M4H41T25C	M4H41T25C1518	1.27
47	73.57	20	3450	M4H74T25C	M4H74T25C2036	1.01
51	34.48	20	1750	M4H34T25C	M4H34T25C2018	1.09
52	66.17	20	3450	M4H66T25C	M4H66T25C2036	1.13
57	61.04	20	3450	M4H61T25C	M4H61T25C2036	1.20
58	30.05	20	1750	M4H30T25C	M4H30T25C2018	1.24
67	51.72	25	3450	M4H52T28TSC	M4H52T28TSC2536	1.10
68	25.57	25	1750	M4H26T28C	M4H26T28C2518	1.13
70	49.04	25	3450	M4H49T28TSC	M4H49T28TSC2536	1.16
78	44.11	30	3450	M4H44T28TSC	M4H44T28TSC3036	1.06
80	21.82	30	1750	M4H22T28C	M4H22T28C3018	1.08
85	40.70	30	3450	M4H41T28TSC	M4H41T28TSC3036	1.13
98	17.89	30	1750	M4H18T28C	M4H18T28C3018	1.29
100	34.48	30	3450	M4H34T28TSC	M4H34T32TSC3036	1.31
115	30.05	40*	3450	M4H30T32TSC	M4H30T32TSC4036	1.07
135	25.57	40*	3450	M4H26T32TSC	M4H26T32TSC4036	1.18
158	21.82	50*	3450	M4H22T32TSC	M4H22T32TSC5036	1.06
193	17.89	50*	3450	M4H18T32TSC	M4H18T32TSC5036	1.19

\* Consult Dodge Engineering for thermal considerations of application

**MTA EZ Selection Tables**  
Class 2, 1.4 Service Factor

**MTA4207H CLASS 2**

Output rpm	Ratio	Class 2 Mtr HP	Mtr speed	Reducer Part Number	C-Face GearMotor Part Number	Service factor
24	73.57	7.5	1750	M4H74T21C	M4H74T21C718	1.53
26	66.17	7.5	1750	M4H66T21C	M4H66T21C718	1.65
29	61.04	7.5	1750	M4H61T21C	M4H61T21C718	1.76
34	51.72	10	1750	M4H52T21C	M4H52T21C1018	1.56
36	49.04	10	1750	M4H49T21C	M4H49T21C1018	1.64
40	44.11	10	1750	M4H44T21C	M4H44T21C1018	1.80
43	40.70	10	1750	M4H41T21C	M4H41T21C1018	1.90
47	73.57	10	3450	M4H74T21C	M4H74T21C1036	2.03
51	34.48	15	1750	M4H34T25C	M4H34T25C1518	1.45
52	66.17	15	3450	M4H66T25C	M4H66T25C1536	1.50
57	61.04	15	3450	M4H61T25C	M4H61T25C1536	1.60
58	30.05	15	1750	M4H30T25C	M4H30T25C1518	1.65
67	51.72	15	3450	M4H52T25C	M4H52T25C1536	1.84
68	25.57	20	1750	M4H26T25C	M4H26T25C2018	1.42
70	49.04	20	3450	M4H49T25C	M4H49T25C2036	1.45
78	44.11	20	3450	M4H44T25C	M4H44T25C2036	1.59
80	21.82	20	1750	M4H22T25C	M4H22T25C2018	1.63
85	40.70	20	3450	M4H41T25C	M4H41T25C2036	1.69
98	17.89	25	1750	M4H18T28C	M4H18T28C2518	1.54
100	34.48	25	3450	M4H34T28TSC	M4H34T28TSC2536	1.57
115	30.05	30	3450	M4H30T28TSC	M4H30T28TSC3036	1.43
135	25.57	30	3450	M4H26T28TSC	M4H26T28TSC3036	1.58
158	21.82	30	3450	M4H22T28TSC	M4H22T28TSC3036	1.76
193	17.89	40*	3450	M4H18T32TSC	M4H18T32TSC4036	1.48

\* Consult Dodge Engineering for thermal considerations of application



**MTA EZ Selection Tables**  
**Class 1, 1.0 Service Factor**

**MTA6307H CLASS 1**

Output rpm	Ratio	Class 1 Mtr HP	Mtr speed	Reducer Part Number	C-Face GearMotor Part Number	Service factor
22	78.53	20	1750	M6H79T25C	M6H79T25C2018	1.18
26	66.92	25	1750	M6H67T28C	M6H67T28C2518	1.10
30	59.05	30	1750	M6H59T28C	M6H59T28C3018	1.05
33	52.35	30	1750	M6H52T28C	M6H52T28C3018	1.14
35	50.26	30	1750	M6H50T28C	M6H50T28C3018	1.21
39	44.61	30	1750	M6H45T28C	M6H45T28C3018	1.33
44	78.53	40	3450	M6H79T32TSC	M6H79T32TSC4036	1.12
44	39.37	40	1750	M6H39T32C	M6H39T32C4018	1.12
52	66.92	50	3450	M6H67T32TSC	M6H67T32TSC5036	1.04
52	33.51	50	1750	M6H34T32C	M6H34T32C5018	1.04
58	59.05	50	3450	M6H59T32TSC	M6H59T32TSC5036	1.15
60	29.03	50	1750	M6H29T32C	M6H29T32C5018	1.19
66	52.35	60	3450	M6H52T36TSC	–	1.08
69	50.26	60	3450	M6H50T36TSC	–	1.12
72	24.43	60	1750	M6H24T36C	–	1.16
77	44.61	60	3450	M6H45T36TSC	–	1.24
79	22.04	60	1750	M6H22T36C	–	1.27
88	39.37	75*	3450	M6H39T36TSC	–	1.11
92	18.95	75*	1750	M6H19T36C	–	1.15
103	33.51	75*	3450	M6H34T36TSC	–	1.26
119	29.03	75*	3450	M6H29T36TSC	–	1.41
141	24.43	75*	3450	M6H24T36TSC	–	1.60
157	22.04	75*	3450	M6H22T36TSC	–	1.72
182	18.95	75*	3450	M6H19T36TSC	–	1.88

\* Consult Dodge Engineering for thermal considerations of application

**MTA EZ Selection Tables**  
**Class 2, 1.4 Service Factor**

**MTA6307H CLASS 2**

Output rpm	Ratio	Class 2 Mtr HP	Mtr speed	Reducer Part Number	C-Face GearMotor Part Number	Service factor
22	78.53	15	1750	M6H79T25C	M6H79T25C1518	1.57
26	66.92	15	1750	M6H67T25C	M6H67T25C1518	1.84
30	59.05	20	1750	M6H59T25C	M6H59T25C2018	1.57
33	52.35	20	1750	M6H52T25C	M6H52T25C2018	1.72
35	50.26	25	1750	M6H50T28C	M6H50T28C2518	1.45
39	44.61	25	1750	M6H45T28C	M6H45T28C2518	1.59
44	78.53	30	3450	M6H79T28TSC	M6H79T28TSC3036	1.49
44	39.37	30	1750	M6H39T28C	M6H39T28C3018	1.49
52	66.92	30	3450	M6H67T28TSC	M6H67T28TSC3036	1.74
52	33.51	30	1750	M6H34T28C	M6H34T28C3018	1.74
58	59.05	40	3450	M6H59T32TSC	M6H59T32TSC4036	1.44
60	29.03	40	1750	M6H29T32C	M6H29T32C4018	1.48
66	52.35	40	3450	M6H52T32TSC	M6H52T32TSC4036	1.62
69	50.26	40	3450	M6H50T32TSC	M6H50T32TSC4036	1.68
72	24.43	50	1750	M6H24T32C	M6H24T32C5018	1.40
77	44.61	50	3450	M6H45T32TSC	M6H45T32TSC5036	1.49
79	22.04	50	1750	M6H22T32C	M6H22T32C5018	1.52
88	39.37	50	3450	M6H39T32TSC	M6H39T32TSC5036	1.66
92	18.95	60	1750	M6H19T36C	–	1.43
103	33.51	60	3450	M6H34T36TSC	–	1.57
119	29.03	75*	3450	M6H29T36TSC	–	1.41
141	24.43	75*	3450	M6H24T36TSC	–	1.60
157	22.04	75*	3450	M6H22T36TSC	–	1.72
182	18.95	75*	3450	M6H19T36TSC	–	1.88

\* Consult Dodge Engineering for thermal considerations of application



**MTA2115 Shaft Mounted Drive**

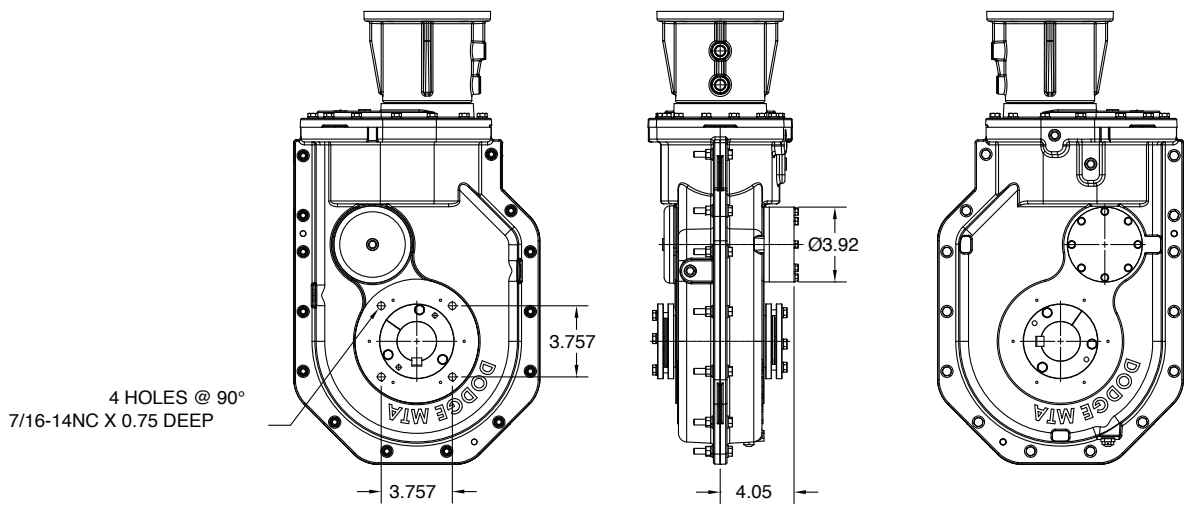
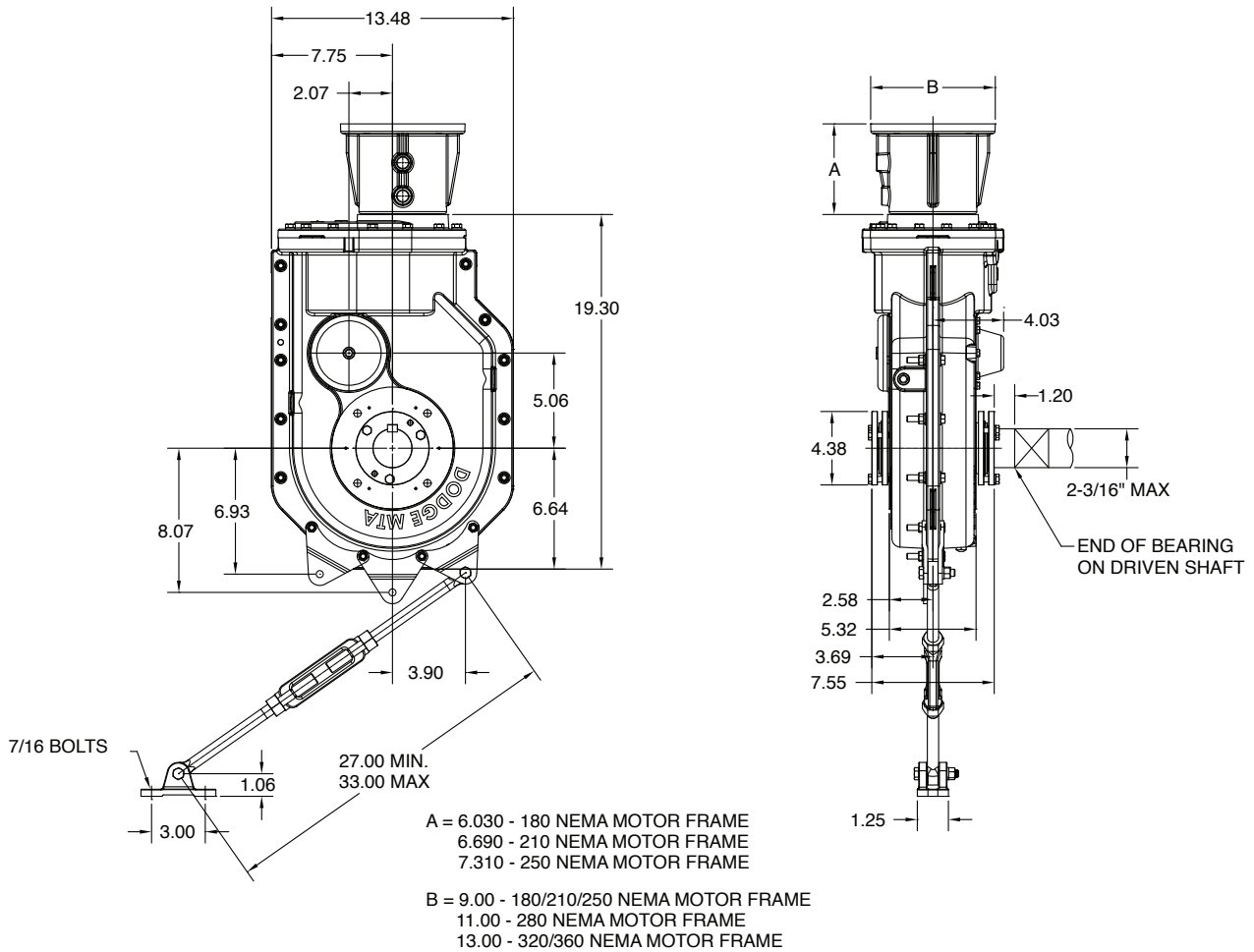

**REDUCER WITH BACKSTOP**





**MTA2115 Shaft Mounted Accessories**

**MTA2115 C-Face Reducer Weights with adapter (lbs)**

		Adapter size						
Reducer	180	210	250	280	280TSC	320	360	320TSC & 360TSC
Weight (lbs)	155	160	165	185	–	–	–	–

**MTA2115H Accessories**

Description	Part Number	Weight lbs.
TA2115RA Rod Assembly	902109	6.9
TA3203BS Backstop Assembly use for MTA2115	903102	4.7
TA0-TA3 Vertical Breather Kit	900112	2.0
Filter Breather	430048	0.2
V-ring Seal Kit	902249	0.1

(2) See page G1-130 for input shaft speed necessary for backstop sprag lift-off

**Bushing & Safety End Covers**

Reducer Size	Metal End Cover Part Numbers			
	Closed	Weight	Split	Weight
MTA2115H	902114	0.6	902115	0.5
Reducer Size	ABS End Cover Part Numbers			
	Closed	Weight	Split	Weight
MTA2115H	454374	0.6	454375	0.5

End covers fit both the outside and inside of MTA reducer.

**TA2115H Tapered Bushing Kits (5) (6)**

Bushing Size Standard Shaft Bushing Kit	Part Number (7)	Weight lbs.	Shaft Keyseat Required (9)(10)
TA2115TB x 2-3/16	902020	4.7	1/2 x 1/4 x 7.80
TA2115TB x 2	902022	5.2	1/2 x 1/4 x 7.80
TA2115TB x 1-15/16 ▲	902023	5.4	1/2 x 1/4 x 7.80
TA2115TB x 1-7/8	902024	5.6	1/2 x 1/4 x 7.80
TA2115TB x 1-3/4	902025	5.8	3/8 x 3/16 x 7.80
TA2115TB x 1-11/16	902026	6.1	3/8 x 3/16 x 7.80
TA2115TB x 1-5/8	902027	6.0	3/8 x 3/16 x 7.80
TA2115TB x 1-1/2	902028	6.4	3/8 x 3/16 x 7.80
TA2115TB x 1-7/16	902029	6.4	3/8 x 3/16 x 7.80
TA2115TB x 1-3/8	902060	6.5	5/16 x 5/32 x 7.80
TA2115TB x 1-5/16	902061	6.7	5/16 x 5/32 x 7.80

**TA2115H Short shaft Tapered Bushing Kits**

Bushing Size Short Shaft Bushing Kit	Part Number (8)	Weight lbs.	Shaft Keyseat Required (9)(10)
TA2115TBS x 1-15/16	902030	5.6	1/2 x 1/4 x 4.80
TA2115TBS x 1-7/8	902031	5.9	1/2 x 1/4 x 4.80
TA2115TBS x 1-3/4	902032	6	3/8 x 3/16 x 4.80
TA2115TBS x 1-11/16	902033	6.6	3/8 x 3/16 x 4.80
TA2115TBS x 1-5/8	902034	6.8	3/8 x 3/16 x 4.80
TA2115TBS x 1-1/2	902035	7.3	3/8 x 3/16 x 4.80
TA2115TBS x 1-7/16	902036	7.4	3/8 x 3/16 x 4.80
TA2115TBS x 1-3/8	902037	7.6	5/16 x 5/32 x 4.80
TA2115TBS x 1-5/16	902038	7.8	5/16 x 5/32 x 4.80

▲ AGMA maximum bore size

(5) Bushing kit required to mount TA II reducer to driven shaft

(6) Bushing kit is not required to mount TA II reducer on SCS Drive Shaft in a screw conveyor application

(7) Standard Shaft Bushing Kit includes two standard bushings with back-up plates and snap rings; hardware, and key

(8) Short Shaft Bushing Kit includes one standard bushing, one long bushing with insertable wedge; two back-up plates with snap rings; hardware and key. This is an optional bushing for after market, short shaft mounting.

(9) Minimum keyseat and shaft length required to mount reducer with bushing kit

(10) Always check the driven shaft and key for strength



MTA2115 Screw Conveyor Drive

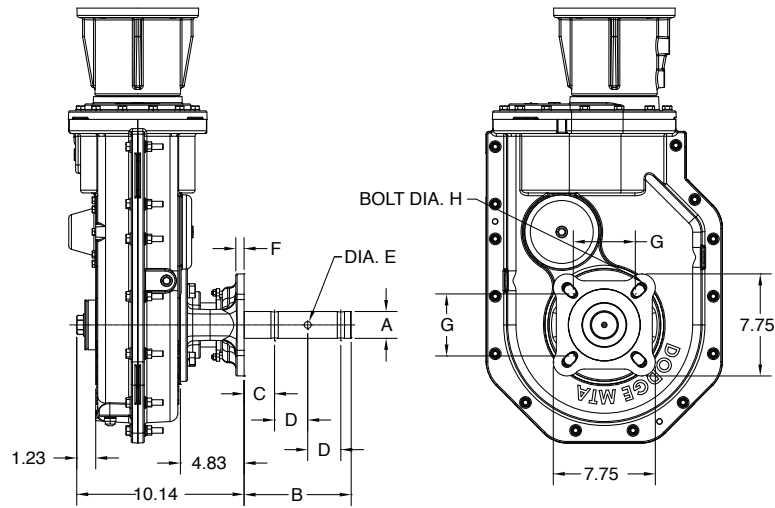

TA2115H Screw Conveyor Drive Dimensions

Dimensions								
Screw Dia	Drive Shaft Dia A	B	C	D	Hole Dia E	F	G	Bolt Dia H
6, 9	1-1/2	9.00	2.13	3.00	17/32	0.75	4.00	1/2-13
9, 12	2	9.00	2.13	3.00	21/32	0.75	5.13	5/8
12, 14	2-7/16	9.69	2.75	3.00	21/32	0.75	5.63	5/8
12, 14, 16,	3	9.88	2.88	3.00	25/32	0.75	6.00	3/4
18, 20	—	—	—	—	—	—	—	—



**MTA2115 Screw Conveyor Accessories**

**Bushing & Safety End Covers**

Reducer Size	Metal End Cover Part Numbers			
	Closed	Weight	Split	Weight
MTA2115H	902114	0.6	902115	0.5

Reducer Size	ABS End Cover Part Numbers			
	Closed	Weight	Split	Weight
MTA2115H	454374	0.6	454375	0.5

End covers fit both the outside and inside of MTA reducer.

**TA2115H Accessories for Screw Conveyor Drives (4) (5)**

Description	Part Number	Weight lbs.
TA2115SCA Adapter & Hardware Kit (2)	902070	19.2
TA2115SCP Adjustable Packing Kit (3)	902071	1.2
TA2115SCS x 1-1/2 Drive Shaft	902072	15.4
TA2115SCS x 2 Drive Shaft	902073	18.6
TA2115SCS x 2-7/16 Drive Shaft	902074	23.3
TA2115SCS x 3 Drive Shaft	902075	29.5
TA2115SCS x 1-1/2 Stainless Steel Drive Shaft	902080	15.4
TA2115SCS x 2 Stainless Steel Drive Shaft	902081	18.6
TA2115SCS x 2-7/16 Stainless Steel Drive Shaft	902082	23.3
TA2115SCS x 3 Stainless Steel Drive Shaft	902083	29.5

- (2) SCA Adapter & Hardware Kit includes adapter, mounting wedge, keeper plate, key, seals and hardware
- (3) SCP Adjustable Packing Kit consists of flange, mounting hardware and braided packing seals
- (4) SCS Drive Shaft is a shaft only. Hardware is stocked with the adapter & hardware kit
- (5) A complete TA II Screw Conveyor Drive includes a TA II Reducer, SCA Adapter & Hardware Kit and SCS Drive Shaft. The SCP Adjustable Packing Kit is an optional accessory.



MTA4207 Shaft Mounted Drive

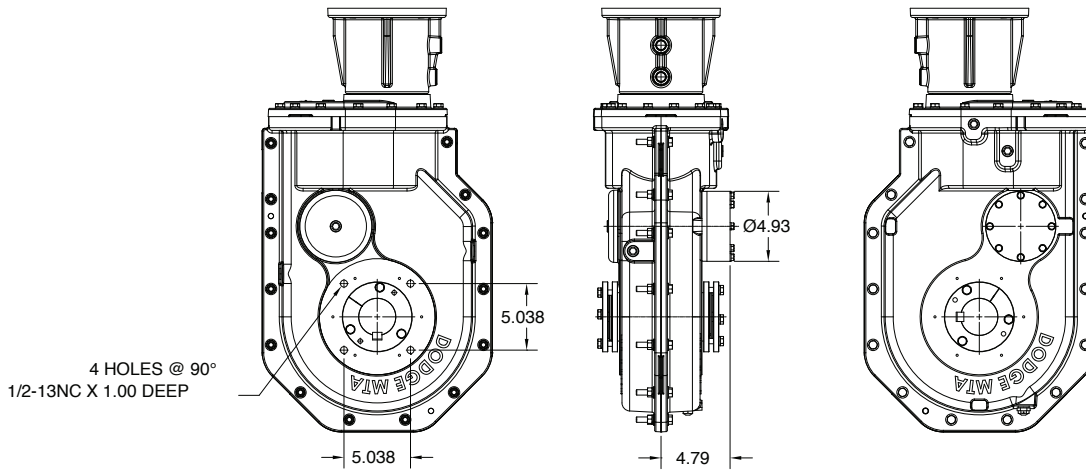
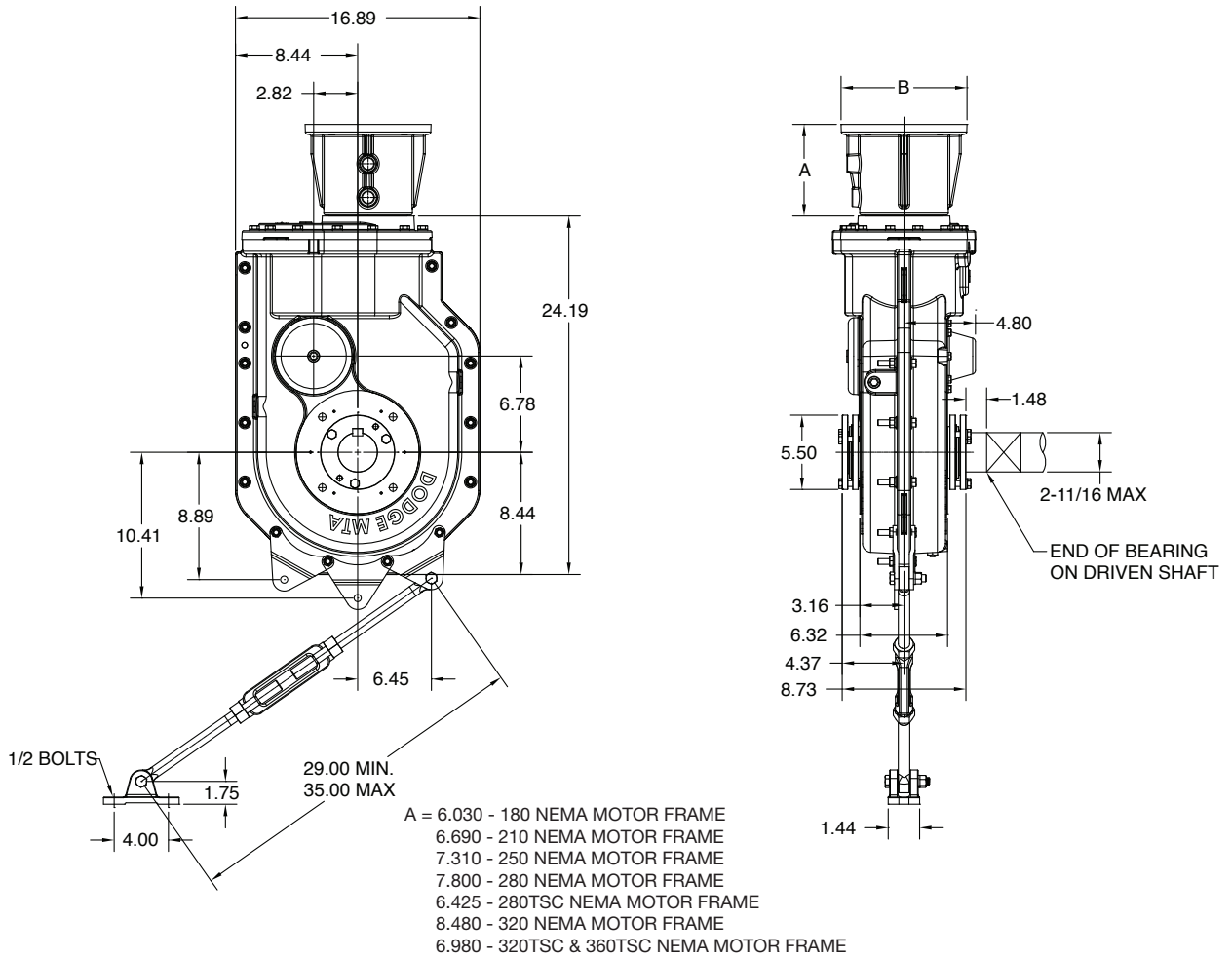

REDUCER WITH BACKSTOP



**MTA4207 Shaft Mounted Accessories**

**MTA4207 C-Face Reducer Weights with adapter (lbs)**

Adapter size								
Reducer	180	210	250	280	280TSC	320	360	320TSC & 360TSC
Weight (lbs)	270	275	280	300	300	–	–	320

**MTA4207H Accessories**

Description	Part Number	Weight lbs.
TA4207RA Rod Assembly	904109	10.6
TA5215BS Backstop Assembly use for MTA4207	905102	8.3
TA4-TA12 Vertical Breather Kit	904112	3.0
Filter Breather	430049	0.2
V-ring Seal Kit	904249	0.2

(2) See page G1-130 for input shaft speed necessary for backstop sprag lift-off

**Bushing & Safety End Covers**

Reducer Size	Metal End Cover Part Numbers			
	Closed	Weight	Split	Weight
MTA4207H	904114	1.2	904115	1.0

Reducer Size	ABS End Cover Part Numbers			
	Closed	Weight	Split	Weight
MTA4207H	454500	1.2	454501	1.0

End covers fit both the outside and inside of MTA reducer.

**TA4207H Tapered Bushing Kits (5) (6)**

Bushing Size Required Standard Shaft Bushing Kit	Part Number (7)	Weight lbs.	Shaft Keyseat (9) (10)
TA4207TB x 2-11/16	904020	9.4	5/8 x 5/16 x 8.93
TA4207TB x 2-1/2	904021	10.6	5/8 x 5/16 x 8.93
TA4207TB x 2-7/16 ▲	904022	10.8	5/8 x 5/16 x 8.93
TA4207TB x 2-3/8	904023	11.3	5/8 x 5/16 x 8.93
TA4207TB x 2-1/4	904024	11.5	1/2 x 1/4 x 8.93
TA4207TB x 2-3/16	904025	11.8	1/2 x 1/4 x 8.93
TA4207TB x 2-1/8	904026	12.2	1/2 x 1/4 x 8.93
TA4207TB x 2	904027	12.6	1/2 x 1/4 x 8.93
TA4207TB x 1-15/16	904028	13.0	1/2 x 1/4 x 8.93
TA4207TB x 1-7/8	904029	13.2	1/2 x 1/4 x 8.93
TA4207TB x 1-3/4	904030	13.3	3/8 x 3/16 x 8.93
TA4207TB x 1-11/16	904031	13.5	3/8 x 3/16 x 8.93

**TA4207H Tapered Short Shaft Bushing Kits (5) (6)**

Bushing Size Required Short Shaft Bushing Kit	Part Number (8)	Weight lbs.	Shaft Keyseat (9) (10)
TA4207TBS x 2-7/16	904032	11.3	5/8 x 5/16 x 5.65
TA4207TBS x 2-3/8	904033	11.8	5/8 x 5/16 x 5.65
TA4207TBS x 2-1/4	904034	12.4	1/2 x 1/4 x 5.65
TA4207TBS x 2-3/16	904035	10.8	1/2 x 1/4 x 5.65
TA4207TBS x 2-1/8	904036	13.3	1/2 x 1/4 x 5.65
TA4207TBS x 2	904037	13.9	1/2 x 1/4 x 5.65
TA4207TBS x 1-15/16	904038	14.3	1/2 x 1/4 x 5.65
TA4207TBS x 1-7/8	904039	14.6	1/2 x 1/4 x 5.65
TA4207TBS x 1-3/4	904040	15.0	3/8 x 3/16 x 5.65
TA4207TBS x 1-11/16	904041	15.3	3/8 x 3/16 x 5.65

▲ AGMA maximum bore size

(5) Bushing kit required to mount TA II reducer to driven shaft

(6) Bushing kit is not required to mount TA II reducer on SCS Drive Shaft in a screw conveyor application

(7) Standard Shaft Bushing Kit includes two standard bushings with back-up plates and snap rings; hardware, and key

(8) Short Shaft Bushing Kit includes one standard bushing, one long bushing with insertable wedge; two back-up plates with snap rings; hardware and key. This is an optional bushing for after market, short shaft mounting.

(9) Minimum keyseat and shaft length required to mount reducer with bushing kit

(10) Always check the driven shaft and key for strength



MTA4207 Screw Conveyor Drive

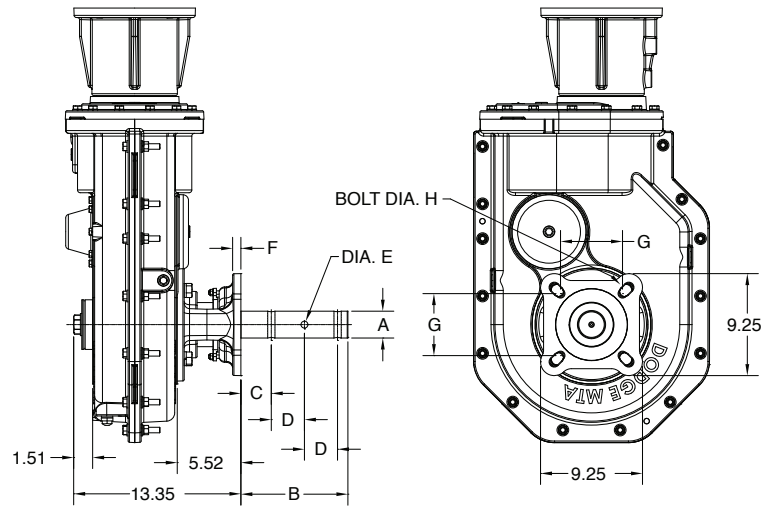

TA4207H Screw Conveyor Drive Dimensions

Screw Dia	Drive Shaft Dia A	Dimensions						
		B	C	D	Hole Dia E	F	G	Bolt Dia H
9, 12	2	9.00	2.13	3.00	21/32	0.75	5.13	5/8
12, 14	2-7/16	9.69	2.75	3.00	21/32	0.75	5.63	5/8
12, 14, 16, 18, 20	3	9.88	2.88	3.00	25/32	0.75	6.00	3/4
18, 20, 24	3-7/16	13.13	3.88	4.00	29/32	0.75	6.75	3/4





**MTA4207 Screw Conveyor Accessories**

**Bushing & Safety End Covers**

Reducer Size	Metal End Cover Part Numbers			
	Closed	Weight	Split	Weight
MTA4207H	904114	1.2	904115	1.0

Reducer Size	ABS End Cover Part Numbers			
	Closed	Weight	Split	Weight
MTA4207H	454500	1.2	454501	1.0

End covers fit both the outside and inside of MTA reducer.

**TA4207H Accessories for Screw Conveyor Drives (4) (5)**

Description	Part Number	Weight lbs.
TA4207SCA Adapter & Hardware Kit (2)	904070	33.6
TA4207SCP Adjustable Packing Kit (3)	904071	2.1
TA4207SCS x 2 Drive Shaft	904073	29.8
TA4207SCS x 2-7/16 Drive Shaft	904074	34.5
TA4207SCS x 3 Drive Shaft	904075	40.9
TA4207SCS x 3-7/16 Drive Shaft	904076	54.7
TA4207SCS x 2 Stainless Steel Drive Shaft	904081	29.8
TA4207SCS x 2-7/16 Stainless Steel Drive Shaft	904082	34.5
TA4207SCS x 3 Stainless Steel Drive Shaft	904083	40.9
TA4207SCS x 3-7/16 Stainless Steel Drive Shaft	904084	54.7

- (2) SCA Adapter & Hardware Kit includes adapter, mounting wedge, keeper plate, key, seals and hardware
- (3) SCP Adjustable Packing Kit consists of flange, mounting hardware and braided packing seals
- (4) SCS Drive Shaft is a shaft only. Hardware is stocked with the adapter & hardware kit
- (5) A complete TA II Screw Conveyor Drive includes a TA II Reducer, SCA Adapter & Hardware Kit and SCS Drive Shaft. The SCP Adjustable Packing Kit is an optional accessory.



MTA6307 Shaft Mounted Accessories

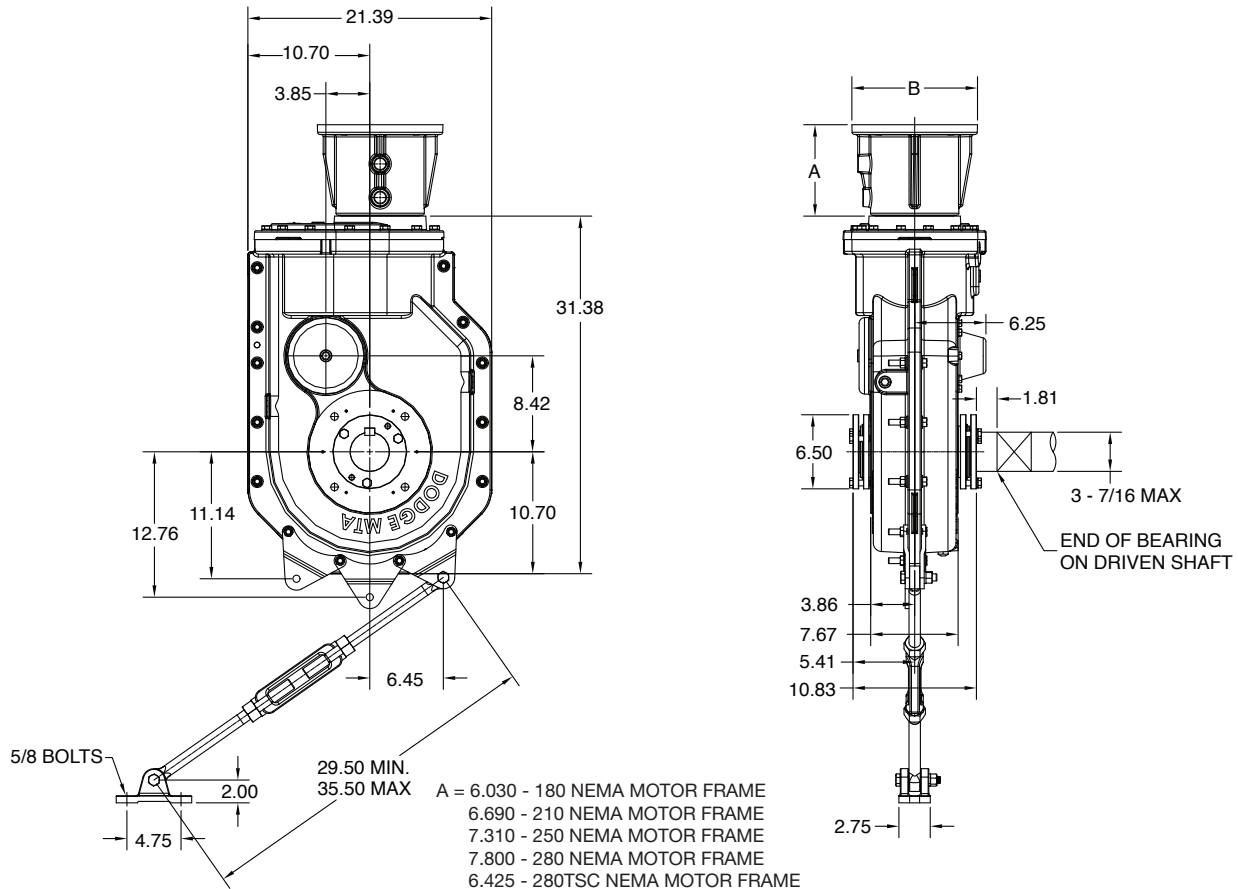

- A = 6.030 - 180 NEMA MOTOR FRAME
- 6.690 - 210 NEMA MOTOR FRAME
- 7.310 - 250 NEMA MOTOR FRAME
- 7.800 - 280 NEMA MOTOR FRAME
- 6.425 - 280TSC NEMA MOTOR FRAME
- 8.480 - 320 NEMA MOTOR FRAME
- 6.980 - 320TSC & 360TSC NEMA MOTOR FRAME
- 9.100 - 360 NEMA MOTOR FRAME
- B = 9.00 - 180/210/250 NEMA MOTOR FRAME
- 11.00 - 280 & 280TSC NEMA MOTOR FRAME
- 13.00 - 320/360 & 320/360TSC NEMA MOTOR FRAME

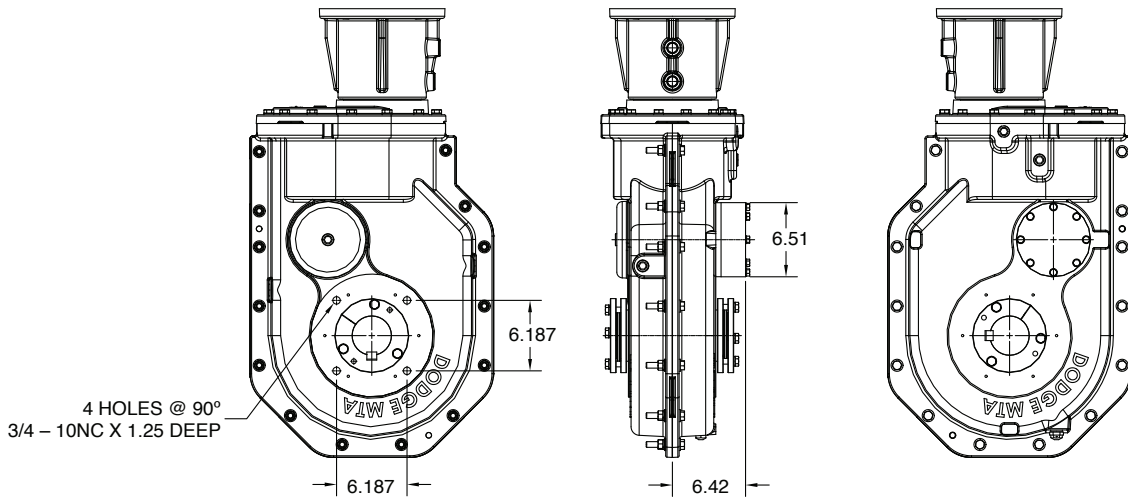

REDUCER WITH BACKSTOP



**MTA6307 Shaft Mounted Accessories**

**MTA6307 C-Face Reducer Weights with adapter (lbs)**

Adapter size								
Reducer	180	210	250	280	280TSC	320	360	320TSC & 360TSC
Weight (lbs)	475	480	485	505	505	525	545	525

**MTA6307H Accessories**

Description	Part	Weight
	Number	lbs.
TA6307RA Rod Assembly	906109	19.9
TA7315BS Backstop Assembly use for MTA6307	907102	20.0
TA4-TA12 Vertical Breather Kit	904112	3.0
Filter Breather	430049	0.2
V-ring Seal Kit	906249	0.3

**Bushing & Safety End Covers**

Reducer Size	Metal End Cover Part Numbers			
	Closed	Weight	Split	Weight
MTA6307H	906114	1.0	906115	1.5
Reducer Size	ABS End Cover Part Numbers			
	Closed	Weight	Split	Weight
MTA6307H	454570	1.0	454571	1.5

End covers fit both the outside and inside of MTA reducer.

**TA6307H Tapered Bushing Kits (5) (6)**

Bushing Size Required Standard Shaft Bushing Kit	Part Number (7)	Weight lbs.	Shaft Keyseat (9) (10)
TA6307TB x 3-7/16	906020	16.7	7/8 x 7/16 x 10.82
TA6307TB x 3-3/16	906021	17.7	3/4 x 3/8 x 10.82
TA6307TB x 3	906022	19.1	3/4 x 3/8 x 10.82
TA6307TB x 2-15/16	906023	19.6	3/4 x 3/8 x 10.82
TA6307TB x 2-7/8	906024	20.1	3/4 x 3/8 x 10.82
TA6307TB x 2-11/16	906025	20.9	5/8 x 5/16 x 10.82
TA6307TB x 2-1/2	906026	22.1	5/8 x 5/16 x 10.82
TA6307TB x 2-7/16	906027	22.3	5/8 x 5/16 x 10.82
TA6307TB x 2-3/8	906028	22.7	5/8 x 5/16 x 10.82
TA6307TB x 2-1/4	906029	23.1	1/2 x 1/4 x 10.82
TA6307TB x 2-3/16	906030	23.3	1/2 x 1/4 x 10.82

**TA6307H Tapered Short Shaft Bushing Kits (5) (6)**

Bushing Size Required Short Shaft Bushing Kit	Part Number (8)	Weight lbs.	Shaft Keyseat (9) (10)
TA6307TBS x 3-7/16	906031	16.5	7/8 x 7/16 x 6.72
TA6307TBS x 3-3/16	906032	19.0	3/4 x 3/8 x 6.72
TA6307TBS x 3	906033	20.9	3/4 x 3/8 x 6.72
TA6307TBS x 2-15/16	906034	21.6	3/4 x 3/8 x 6.72
TA6307TBS x 2-7/8	906035	22.3	3/4 x 3/8 x 6.72
TA6307TBS x 2-11/16	906036	23.7	5/8 x 5/16 x 6.72
TA6307TBS x 2-1/2	906037	25.3	5/8 x 5/16 x 6.72
TA6307TBS x 2-7/16	906038	25.8	5/8 x 5/16 x 6.72
TA6307TBS x 2-3/8	906039	26.3	5/8 x 5/16 x 6.72
TA6307TBS x 2-1/4	906040	26.7	1/2 x 1/4 x 6.72
TA6307TBS x 2-3/16	906041	27.5	1/2 x 1/4 x 6.72

- ▲ AGMA maximum bore size
- (5) Bushing kit required to mount TA II reducer to driven shaft
- (6) Bushing kit is not required to mount TA II reducer on SCS Drive Shaft in a screw conveyor application
- (7) Standard Shaft Bushing Kit includes two standard bushings with back-up plates and snap rings; hardware, and key
- (8) Short Shaft Bushing Kit includes one standard bushing, one long bushing with insertable wedge; two back-up plates with snap rings; hardware and key. This is an optional bushing for after market, short shaft mounting.
- (9) Minimum keyseat and shaft length required to mount reducer with bushing kit
- (10) Always check the driven shaft and key for strength



MTA6307 Screw Conveyor Drive

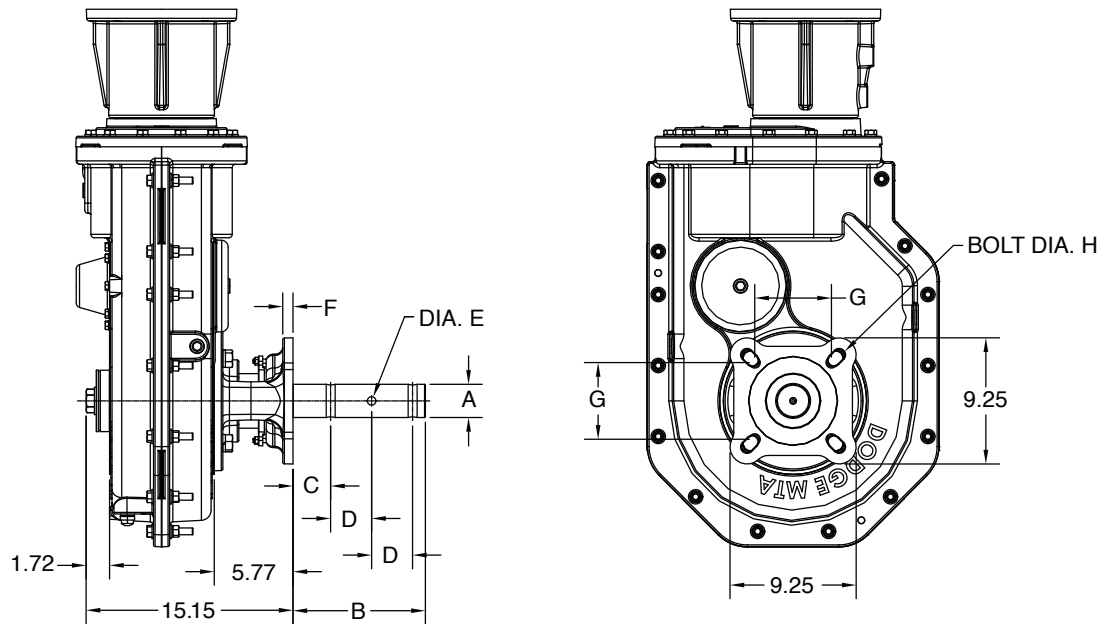

SCREW CONVEYOR DRIVE

TA6307H Screw Conveyor Drive Dimensions

Screw Dia	Drive Shaft Dia A	Dimensions						
		B	C	D	Hole Dia E	F	G	Bolt Dia H
12, 14	2-7/16	9.69	2.75	3.00	21/32	0.75	5.63	5/8
12, 14, 16, 18, 20	3	9.88	2.88	3.00	25/32	0.75	6.00	3/4
18, 20, 24	3-7/16	13.13	3.88	4.00	29/32	0.75	6.75	3/4



**MTA6307 Screw Conveyor Drive**

**Bushing & Safety End Covers**

Reducer Size	Metal End Cover Part Numbers			
	Closed	Weight	Split	Weight
MTA6307H	906114	1.0	906115	1.5

Reducer Size	ABS End Cover Part Numbers			
	Closed	Weight	Split	Weight
MTA6307H	454570	1.0	454571	1.5

End covers fit both the outside and inside of MTA reducer.

**TA6307H Accessories for Screw Conveyor Drives (4) (5)**

Description	Part Number	Weight lbs.
TA6307SCA Adapter & Hardware Kit (2)	906070	40.0
TA6307SCP Adjustable Packing Kit (3)	906071	2.4
TA6307SCS x 2-7/16 Drive Shaft	906074	54.6
TA6307SCS x 3 Drive Shaft	906075	61.0
TA6307SCS x 3-7/16 Drive Shaft	906076	74.9
TA6307SCS x 2-7/16 Stainless Steel Drive Shaft	906082	54.6
TA6307SCS x 3 Stainless Steel Drive Shaft	906083	61.0
TA6307SCS x 3-7/16 Stainless Steel Drive Shaft	906084	74.9

(2) SCA Adapter & Hardware Kit includes adapter, mounting wedge, keeper plate, key, seals and hardware

(3) SCP Adjustable Packing Kit consists of flange, mounting hardware and braided packing seals

(4) SCS Drive Shaft is a shaft only. Hardware is stocked with the adapter & hardware kit

(5) A complete TA II Screw Conveyor Drive includes a TA II Reducer, SCA Adapter & Hardware Kit and SCS Drive Shaft. The SCP Adjustable Packing Kit is an optional accessory.



## Harsh Duty Accessories

### Oil Sump Immersion Heaters (1) (2)

Reducer Size	Part Number
TA0	Not Available
TA1-TA3	241103
TA4-TA5	241104
TA6-TA12	Consult DODGE

- (1) 110 volt, single phase, AC cartridge heater, threads into special tapped housing hole. Provides for approximately 70 degrees (F) temperatures rise in one hour for cold climates. Simple time phased on/off construction without thermostat.
- (2) All TA II reducers have to be factory modified to allow installation of sump heater. Consult DODGE.

### Harsh Duty Breathers

Chamber		Filter Breather (3)	
Reducer Size	Part Number	Reducer Size	Part Number
TA0-TA9	240050	TA0-TA3	430048
TA10-TA12	240051	TA4-TA12	430049

- (3) 40 micron mesh opening in filter allows reducer to breathe, yet keeps dust out, under the most extreme conditions.

### Bushing End Covers (4)

Reducer Size	Metal End Cover Part Numbers			Weight
	Closed	Weight	Split	
TA2115H	902114	0.6	902115	0.5
TA4207H	904114	1.2	904115	1.0
TA6307H	906114	1.0	906115	1.5

Reducer Size	ABS End Cover Part Numbers			Weight
	Closed	Weight	Split	
TA2115H	454374	0.6	454375	0.5
TA4207H	454500	1.2	454501	1.0
TA6307H	454570	1.0	454571	1.5

- (4) End covers fit both the input side and backstop side of MTA reducer.

### V-ring Seal Kits

Reducer Size	Part	Weight
MTA2115H	902249	0.1
MTA4207H	904249	0.2
MTA6307H	906249	0.3

## Aftermarket Replacement Parts

### Motorized Torque-Arm Seal Kits (5)

Reducer Size	Part Number	Weight
MTA2115H	M2SEALKIT	0.60
MTA4207H	M4SEALKIT	1.00
MTA6307H	M6SEALKIT	1.50

- (5) Kit includes 2 output seals, 1 input seal, 2 output excluder seals

### Motorized Torque-Arm Backstop Cover and Gasket (6)

Reducer Size	Part Number	Weight
MTA2115H	M2BSCVRKIT	0.40
MTA4207H	M4BSCVRKIT	0.50
MTA6307H	M6BSCVRKIT	0.70

- (6) Kit includes backstop cover and cork gasket

### Motorized Torque-Arm Coupling Replacement Parts (7)

#### Full Coupling

Part numbers for motor frames listed below

Reducer Size	180	210	250	280	320	360
MTA2115H	M2-18CPLKIT	M2-21CPLKIT	M2-25CPLKIT	–	–	–
MTA4207H	M4-18CPLKIT	M421CPLKIT	M4-25CPLKIT	M4-28CPLKIT	M4-32CPLKIT	–
MTA6307H	–	M6-21CPLKIT	M6-25CPLKIT	M6-28CPLKIT	M6-32CPLKIT	M6-36CPLKIT

- (7) Kit includes two coupling halves and element

#### Coupling ELEMENT ONLY

Part Numbers for Motor Frames

Reducer Size	180	210	250	280	320	360
MTA2115H	334291	334291	334291	–	–	–
MTA4207H	454424	454424	454424	454424	454434	–
MTA6307H	–	454424	454424	454424	454434	454434





**MTA Engineering Information**

**Thrust Capacity for Screw Conveyor Drives (Pounds)**

Case Size	Output Speed (RPM)								
	10	25	50	75	100	125	150	175	200
TA2115H	6000	6000	6000	5323	4850	4550	4295	4086	3924
TA4207H	6000	6000	6000	6000	6000	6000	6000	6000	6000
TA6307H	6000	6000	6000	5885	5185	4706	4435	4303	4269

† Consult DODGE

Horsepower	NEMA Motor Frame	Shaft Diameter
3	182T	1-1/8
5	184T	1-1/8
7-1/2	213T	1-3/8
10	215T	1-3/8
15	254T	1-5/8
20	256T	1-5/8
25	284T	1-7/8
25	284TSC 3600rpm	1-5/8
30	286T	1-7/8
30	286TSC 3600rpm	1-5/8

Horsepower	NEMA Motor Frame	Shaft Diameter
40	324T	2-1/8
40	324TSC 3600rpm	1-7/8
50	326T	2-1/8
50	326TSC 3600rpm	1-7/8
60	364T	2-3/8
60	364TSC 3600rpm	1-7/8
75	365T	2-3/8
75	365TSC 3600rpm	1-7/8

**C-Face Reducer Weights with adapter (lbs)**

Reducer	Adapter size							
	180	210	250	280	280TSC	320	360	320TSC & 360TSC
MTA2115	155	160	165	185	-	-	-	-
MTA2407	270	275	280	300	300	-	-	320
MTA6307	475	480	485	505	505	525	525	525



## Mounting Positions

### HORIZONTAL MOUNTING

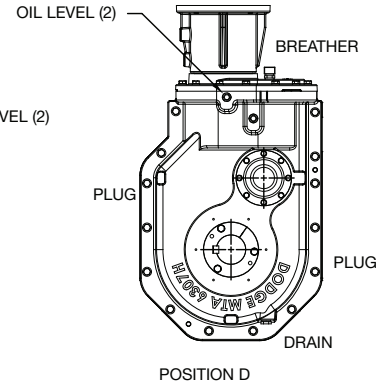
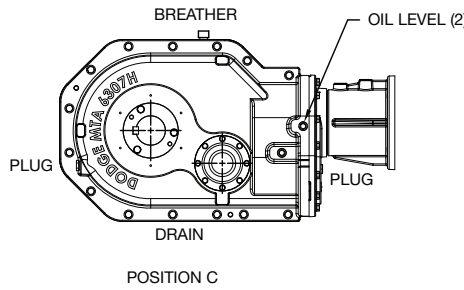
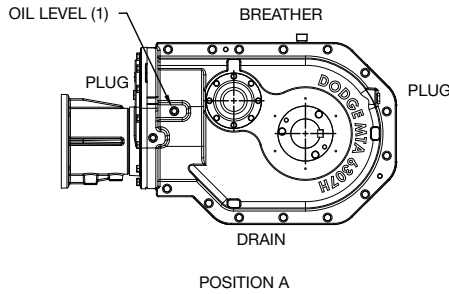

POSITION A

POSITION C

POSITION D

FIGURE 1

### VERTICAL MOUNTING

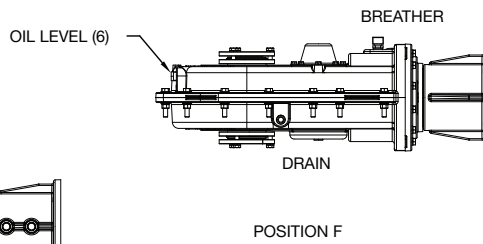
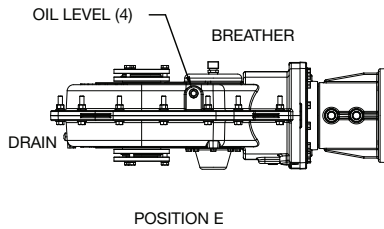

POSITION E

POSITION F

### TYPICAL OIL HOLE LOCATIONS

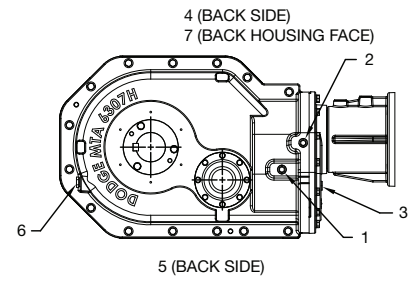

### Vent and Plug Locations

Mounting Position	Vent and Plug Locations for all Speeds						
	1	2	3	4	5	6	7
Position A	Oil Level	Plug	Plug	Drain	Breather	Plug	Plug
Position C	Plug	Oil Level	Plug	Breather	Drain	Plug	Plug
Position D	Plug	Oil Level	Breather	Plug	Plug	Drain	Plug
Position E	Plug	Plug	Plug	Oil Level	Plug	Drain	Breather
Position F	Breather	Plug	Plug	Plug	Plug	Oil Level	Drain

### Oil Volumes

Case Size	Oil Volume in Quarts †▲						Oil Volume in Liters †▲					
	Horizontal				Vertical		Horizontal				Vertical	
	A	B	C	D	E (Up)	F (Down)	A	B	C	D	E (Up)	F (Down)
MTA2115H	4.75		4.13	7.25	6.00	6.00	4.50		3.88	6.88	5.63	5.63
MTA4207H	9.50		8.25	14.38	11.25	11.25	9.00		7.75	13.50	10.63	10.63
MTA6307H	21.00		17.50	31.75	27.75	26.88	20.00		16.50	30.00	26.25	25.38

† Refer to Figure 1 for mounting positions

Oil quantity is approximate. Service with lubricant until oil runs out of oil level hole

▲ US measure: 1 quart = 32 fluid ounces = .94646 liters

Below 15 RPM output speed, oil level must be adjusted to reach the highest oil level plug. If reducer position is to vary from those shown in Figure 1, either more or less oil may be required. Consult DODGE.

Position B not recommended, check with factory



## MTA Engineering Information

### Oil Viscosity Equivalence Chart

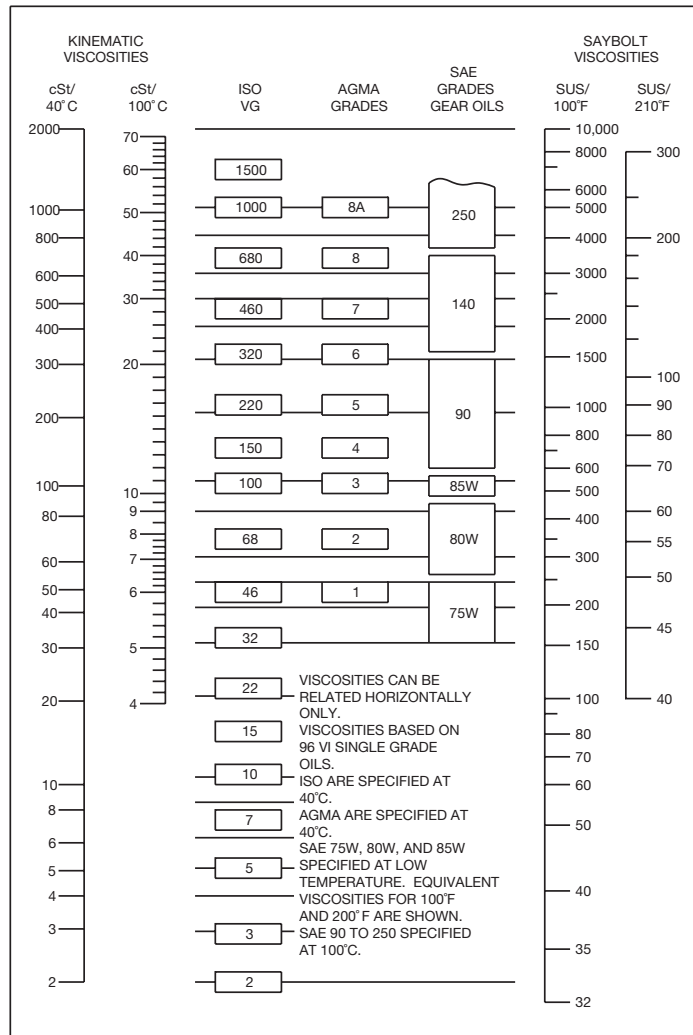

### Recommended Lubricants for Motorized Torque Arm II Reducers

		Standard Oils	EP Oils	
<b>EXXON</b>				
150	Teresstic	150	Spartan EP	150
220		220		220
320		320		320
<b>CHEVRON</b>				
150	Machine	150	Gear Compound EP	150
220		220		220
320		320		320
<b>UNICAL</b>				
150	Turbine Oil	150	Extra Duty HL Gear Lube	141
220		220		207
320		320		300
<b>MOBIL SYNTHETIC</b>				
150	SHC	629	MobilGear SHC	150
220		630		220
320		632		320
<b>MOBIL</b>				
150	Mobil DTE	Extra Heavy	MobilGear 600 XP	150
220		BB		220
320		AA		320
<b>TEXACO</b>				
150	Regal Oil R&O	150	Meropa	150
220		220		220
320		320		320
<b>SHELL</b>				
150	Morlina S2 B	150	Omala S2 G	150
220		220		220
320		320		320

+ Partial list. Consult DODGE or a lubricant manufacturer for further options

### Table 1 – Oil Recommendations

Output RPM	ISO Grades For Ambient Temperatures of 50°F to 125°F		
	Motorized Torque-Arm II Reducer Size		
	MTA2115H	MTA4207H	MTA6307H
151 – 200	320	220	220
126 – 150	320	220	220
101 – 125	320	220	220
81 – 100	320	320	220
41 – 80	320	320	220
11 – 40	320	320	320
1 – 10	320	320	320

### Table 2 – Oil Recommendations

Output RPM	ISO Grades For Ambient Temperatures of 15°F to 60°F		
	Motorized Torque-Arm II Reducer Size		
	MTA2115H	MTA4207H	MTA6307H
151 – 200	220	150	150
126 – 150	220	150	150
101 – 125	220	150	150
81 – 100	220	220	150
41 – 80	220	220	150
11 – 40	220	220	220
1 – 10	220	220	220

- Assumes auxiliary cooling where recommended in the catalog.
- Pour point of lubricant selected should be at least 10°F lower than expected minimum ambient starting temperature.
- Extreme pressure (EP) lubricates are not necessary for average operating conditions. When properly selected for specific applications, TORQUE-ARM II backstops are suitable for use with EP lubricants.
- Special lubricants may be required for food and drug industry applications where contact with the product being manufactured may occur. Consult a lubrication manufacturer's representative for his recommendations.
- For reducers operating in ambient temperatures between -22°F (-30°C) and 20°F (-6.6°C) use a synthetic hydrocarbon lubricant, 100 ISO grade or AGMA 3 grade (for example, Mobil SHC627). Above 125°F (51°C), consult DODGE Gear Application Engineering (864) 297-4800
- Mobil SHC630 Series oil is recommended for high ambient temperatures.

**DODGE MOTORIZED TORQUE-ARM II Speed Reducers – General Specification:**

The speed reducer shall be coupled enclosed shaft mount type unit with a triple reduction ratio. The reducer shall mount directly on the driven shaft and utilize an adjustable torque arm that attaches from the gear case to the support structure or foundation. The motor shall be attached to the reducer with a cast iron adapter and shall utilize a flexible, jaw style, 3 piece coupling to eliminate fretting corrosion and allow for any minor misalignment issues.

The reducer housing shall be constructed of two piece corrosion resistant, class 30 gray iron. All housings shall be doweled and precision machined to assure accurate alignment for all gear sets. Pry slots are provided for ease of repair.

All gearing shall be of helical or helical/bevel design, case carburized and precision finished to insure a high surface durability with a resilient tooth core for impact resistance and optimum service life. Input pinion shall be supported between bearings to maintain proper alignment of gear meshes, maximize load carrying capabilities, and to eliminate overhung loads imposed on bearings. Design meets or exceeds AGMA standards.

Reducer bearings shall be of the tapered roller type, meet or exceed AGMA standards, and provide a 25,000 hour average life, 5,000 L-10 AGMA Class I standard.

All seals shall be of the lip, spring loaded type, made of Hydrogenated Nitrile Butadiene Rubber. A metal excluder seal with rubber lip shall be external to the standard oil seal on all outboard seals.

Reducer installation shall be accomplished by using ductile iron, fully split, two bushing system. Reducer removal shall be accomplished by providing jack screw holes in the bushing flanges to mechanically remove the tapered assembly.

Backstops shall be lift-off sprag type and designed for use with standard and extreme pressure (EP) lubricants.

**DODGE MOTORIZED TORQUE-ARM II Screw Conveyor Drives – General Specification:**

The drive shall consist of a direct drive speed reducer; a cast iron, bolt on, four bolt mounting adapter with double lip seals on both ends, and optional bolt on adjustable packing kit.

A standard three-hole drive shaft will be machined from a high quality alloy steel.

The drive shall conform to Conveyor Equipment Manufacturers Association (CEMA) standards.



For Additional Gearing Information Please See the Following Publications:



**2009 Custom Classics Catalog CA5001**

- Master XL Right Angle
- Master XL Parallel
- Combination Tiger
- APG
- Reeves MotoDrive
- Ultima
- Janior & Senior Pulley



**2009 Quantis Engineering Catalog CA1603**

- In Line Helical (ILH)
- Right Angle Helical Bevel (RHB)
- Motorized Shaft Mount (MSM)
- Eight sizes (38 through 168)
- Four Input Configurations
- Torque Ratings up to 120k in-lbs
- High efficiency product

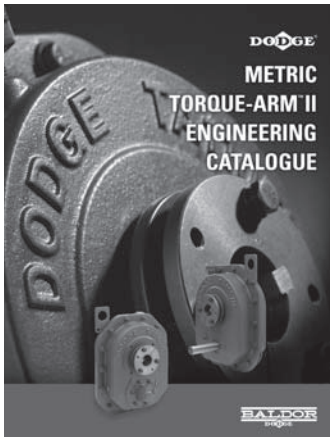

**Metric Torque Arm II ICA1602**

- 12 case sizes
- Metric TAIL Reducers
- Metric Twin Taper Bushings
- Metric Modular accessories
- Shaft sizes up to 190mm
- Torque Ratings up to 50,000 N-M

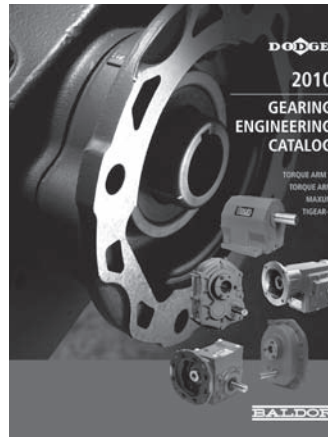

**2010 Gearing Engineering Catalog CA1601**

- Torque-Arm II
  - 12 case sizes
  - Shaft sizes up to 7"
  - Torque ratings up to 328,000 in/lbs
  - HNBR seals
  - EP lube compatible backstop design
- Torque-Arm
  - TXT
    - 14 case sizes, up to 10" shaft size
    - Torque ratings up to 1,000,000 in/lbs
  - SCXT
    - 8 case sizes
    - Torque ratings up to 110,000 in/lbs
  - HXT/HSCXT
    - 7 case sizes, up to 57,000 in/lbs
  - SAE and Char-Lynn style inputs
  - ABHS
    - Airport Baggage handling leading
  - Bio Disc
    - Wastewater treatment design
- Maxum
  - 8 case sizes
  - Torque ratings up to 502,000 in/lbs
- Tigear 2
  - 10 case sizes, up to 4.75 C.D.
  - Ratings up to 7,000 in/lbs
  - Enhanced Washdown
    - EZKleen
    - UltraKleen



**MagnaGear XTR Reducers CA1610**

- 8 case sizes
- Parallel and Right Angle configurations
- Base or Shaft mounted
- Solid or hollow shaft output
- Torque ratings up to 1,000,000 in/lbs



---

P.O. Box 2400, Fort Smith, AR 72902-2400 U.S.A., Ph: (1) 479.646.4711, Fax (1) 479.648.5792, International Fax (1) 479.648.5895

**Baldor - Dodge**

6040 Ponders Court, Greenville, SC 29615-4617 U.S.A., Ph: (1) 864.297.4800, Fax: (1) 864.281.2433

**[www.baldor.com](http://www.baldor.com)**