

For New Technology Network

NTN®

NTN corporation

MLE Bearings

〈BEAREE〉

CAT. No. 5116-I / E



MLE bearings are environmentally-friendly, clean, lead-free sliding bearings that exhibit excellent sliding characteristic under high surface pressures. The "E" in MLE stands for "eco-material."



1. Features

- Oilless sliding bearings capable of use with great loads
- Useable in a wide temperature range from very low to very high temperatures
- Thin walls (1.0 to 2.5 mm) help realize a very compact design
- Low friction coefficient (μ : 0.04-0.20)
- Boasts excellent wear resistance and is capable of operation for a long time

2. Characteristics

Allowable surface pressure	49MPa (137MPa) {500kgf/cm ² (1400kgf/cm ²)}
Allowable sliding velocity	100m/min
Allowable PV value	98MPa · m/min {1000kgf/cm ² · m/min}
Operating temperature range	-200°C~+260°C

Values in () were obtained in a static loading condition and the test results are from NTN bearing test methods.

3. Structure

The structure of an MLE bearing is comprised of three layers – a steel sheet as a backing metal, a porous sintered layer prepared by sintering bronze powder on the steel sheet and a resin layer formed by impregnating the porous sintered layer with a silicone tetrafluoride resin that contains a special filler. This structure boasts a greater load bearing capacity and good heat dissipation performance, and it can operate for a prolonged period without needing relubrication. The steel sheet backing metal is tin-plated for better corrosion resistance.

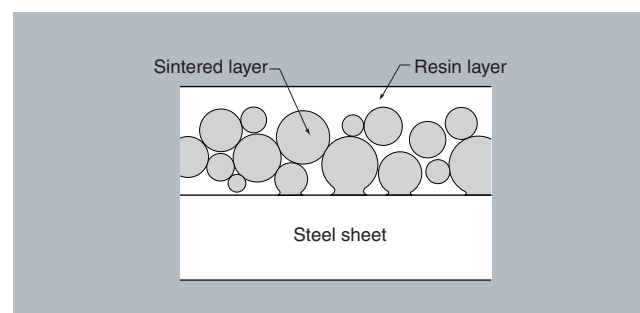

4. Allowable PV values

A PV value is expressed as the product of a surface pressure P and a sliding velocity V , wherein the PV values possible with a normally operating bearing are the allowable PV values for that bearing.

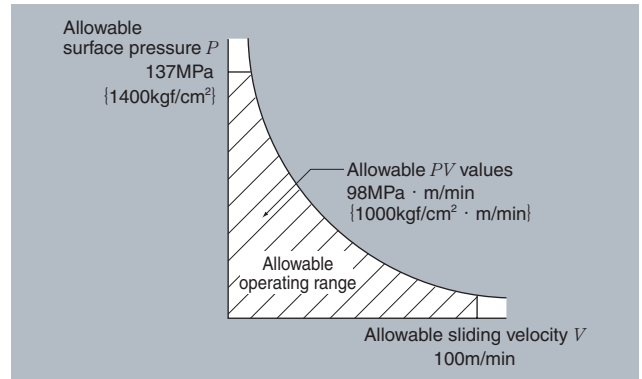

5. Estimated wear

The amount of wear on a given bearing can vary depending on the sliding velocity, surface pressure, operating mode, lubrication conditions, surface roughness of the mating material, ambient temperature and other parameters related to that bearing. Usually, the amount of wear for a particular bearing can be determined with the expression below:

$$R = KPVT$$

where, R : mm of wear

K : specific wear $\text{mm}^3/\text{N} \cdot \text{m}$

Non-lubrication : $K = 1.7 \times 10^{-7}$, oil-lubrication : $K = 1.7 \times 10^{-9}$

P : surface pressure in MPa

V : sliding velocity in m/min

T : time in min

To help minimize the amount of wear, we recommend the use of a shaft with a surface roughness that ranges from 0.1 to 0.8 μmRa and a hardness that is higher than 22 HRC.

6. Fit and clearance

The recommended values for the shaft and housing for MLE and MLEF bearings are given in the dimensions table.

Assuming that the housing is a rigid body and its wall thickness does not vary when it is press-fit, the clearance between an MLE or MLEF bearing and its shaft can be defined as follows:

Minimum clearance =

(housing I.D. min - $2 \times$ max wall thickness) - max shaft dia.

Maximum clearance =

(housing I.D. max - $2 \times$ min wall thickness) - min shaft dia.

If you intend to use a shaft or housing that has a diameter other than one that is recommended, be extremely careful to provide an acceptable clearance.

7. Installation method

When press-fitting an MLE bearing, do not drive it in with a hammer etc.

For the press-fitting operation, use a press-fitting tool / mandrel like the one illustrated below. Provide a sufficiently large guide surface on the inlet of the housing, center the shaft with the housing bore, and then press-fit the bearing using a press.

Preferable types of chamfering are R -chamfering and taper-chamfering. When using C -chamfering ($C1.0$ or lower), make sure that the chamfered area is free from burs.

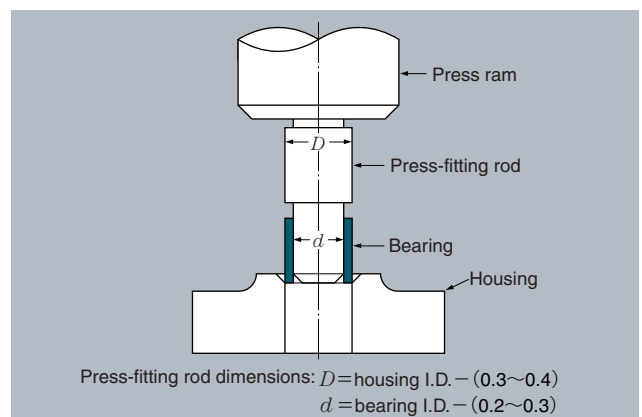

8. Dimension table for MLE bearings

Inner diameter <i>d</i>	Outer diameter <i>D</i>	Length $L_{0.4}^0$											
		4	5	6	7	8	10	12	15	20	25	30	35
3	5		MLE0305	MLE0306									
4	6	MLE0404		MLE0406		MLE0408							
5	7	MLE0504	MLE0505	MLE0506		MLE0508							
6	8		MLE0605	MLE0606	MLE0607	MLE0608	MLE0610						
7	9		MLE0705		MLE0707		MLE0710	MLE0712					
8	10		MLE0805	MLE0806	MLE0807	MLE0808	MLE0810	MLE0812					
9	11				MLE0907		MLE0910						
10	12			MLE1006	MLE1007	MLE1008	MLE1010	MLE1012	MLE1015	MLE1020			
12	14			MLE1206		MLE1208	MLE1210	MLE1212	MLE1215	MLE1220			
13	15					MLE1308	MLE1310		MLE1315				
14	16						MLE1410	MLE1412	MLE1415	MLE1420			
15	17					MLE1508	MLE1510	MLE1512	MLE1515	MLE1520	MLE1525		
16	18						MLE1610	MLE1612	MLE1615	MLE1620	MLE1625		
17	19								MLE1715	MLE1720			
18	20						MLE1810	MLE1812	MLE1815	MLE1820	MLE1825		
19	22						MLE1910		MLE1915				
20	23						MLE2010	MLE2012	MLE2015	MLE2020	MLE2025	MLE2030	
22	25						MLE2210	MLE2212	MLE2215	MLE2220	MLE2225	MLE2230	
24	27						MLE2410		MLE2415		MLE2425	MLE2430	
25	28						MLE2510	MLE2512	MLE2515	MLE2520	MLE2525	MLE2530	MLE2535
26	30											MLE2630	
28	32						MLE2810	MLE2812		MLE2820	MLE2825	MLE2830	
30	34						MLE3010	MLE3012	MLE3015	MLE3020	MLE3025	MLE3030	MLE3035
31	35								MLE3115				
32	36									MLE3220	MLE3225	MLE3230	MLE3235
35	39							MLE3512	MLE3515	MLE3520	MLE3525	MLE3530	MLE3535
38	42									MLE3820	MLE3825		
40	44							MLE4012	MLE4015	MLE4020	MLE4025	MLE4030	MLE4035
45	50									MLE4520	MLE4525	MLE4530	MLE4535
50	55							MLE5012	MLE5015	MLE5020	MLE5025	MLE5030	MLE5035
55	60										MLE5525	MLE5530	MLE5535
60	65									MLE6020		MLE6030	MLE6035
65	70								MLE6515			MLE6530	
70	75								MLE7015	MLE7020		MLE7030	MLE7035
75	80									MLE7520		MLE7530	MLE7535
80	85								MLE8015	MLE8020		MLE8030	
85	90											MLE8530	
90	95									MLE9020			MLE9035
95	100											MLE9530	
100	105											MLE10030	MLE10035
105	110												
110	115									MLE11020		MLE11030	MLE11035
120	125												
130	135									MLE13020			
140	145												
150	155												
160	165												

▼ Indication of Serial Number

R-MLE ○○○○

— Length

— Inner diameter

— Model code

Dimensions to be measured at 25°C / Unit in mm

Length L _{-0.4} ⁰								Wall thickness T	Recommended dimensions		Installed clearance (When installed to H7 cemented carbide housing)	
40	50	60	70	80	90	95	100		Shaft	H7 Housing	Min.	Max.
								1.0 _{-0.025} ⁰	3 _{-0.035} ^{-0.025}	5 (H7) ₀ ^{+0.012}	0.025	0.097
									4 _{-0.037} ^{-0.025}	6 (H7) ₀ ^{+0.012}	0.025	0.099
									5 _{-0.037} ^{-0.025}	7 (H7) ₀ ^{+0.015}	0.025	0.102
									6 _{-0.037} ^{-0.025}	8 (H7) ₀ ^{+0.015}	0.025	0.102
									7 _{-0.040} ^{-0.025}	9 (H7) ₀ ^{+0.015}	0.025	0.105
									8 _{-0.040} ^{-0.025}	10 (H7) ₀ ^{+0.015}	0.025	0.105
									9 _{-0.040} ^{-0.025}	11 (H7) ₀ ^{+0.018}	0.025	0.108
									10 _{-0.040} ^{-0.025}	12 (H7) ₀ ^{+0.018}	0.025	0.108
									12 _{-0.043} ^{-0.025}	14 (H7) ₀ ^{+0.018}	0.025	0.111
									13 _{-0.043} ^{-0.025}	15 (H7) ₀ ^{+0.018}	0.025	0.111
									14 _{-0.043} ^{-0.025}	16 (H7) ₀ ^{+0.018}	0.025	0.111
									15 _{-0.043} ^{-0.025}	17 (H7) ₀ ^{+0.018}	0.025	0.111
									16 _{-0.043} ^{-0.025}	18 (H7) ₀ ^{+0.018}	0.025	0.111
									17 _{-0.043} ^{-0.025}	19 (H7) ₀ ^{+0.021}	0.025	0.114
									18 _{-0.043} ^{-0.025}	20 (H7) ₀ ^{+0.021}	0.025	0.114
									19 _{-0.046} ^{-0.025}	22 (H7) ₀ ^{+0.021}	0.025	0.127
									20 _{-0.046} ^{-0.025}	23 (H7) ₀ ^{+0.021}	0.025	0.127
								22 _{-0.046} ^{-0.025}	25 (H7) ₀ ^{+0.021}	0.025	0.127	
								24 _{-0.046} ^{-0.025}	27 (H7) ₀ ^{+0.021}	0.025	0.127	
MLE2540								25 _{-0.046} ^{-0.025}	28 (H7) ₀ ^{+0.021}	0.025	0.127	
								26 _{-0.046} ^{-0.025}	30 (H7) ₀ ^{+0.021}	0.025	0.127	
								28 _{-0.046} ^{-0.025}	32 (H7) ₀ ^{+0.025}	0.025	0.131	
MLE3040								30 _{-0.046} ^{-0.025}	34 (H7) ₀ ^{+0.025}	0.025	0.131	
MLE3140								31 _{-0.050} ^{-0.025}	35 (H7) ₀ ^{+0.025}	0.025	0.135	
MLE3240	MLE3250							32 _{-0.050} ^{-0.025}	36 (H7) ₀ ^{+0.025}	0.025	0.135	
MLE3540	MLE3550							35 _{-0.050} ^{-0.025}	39 (H7) ₀ ^{+0.025}	0.025	0.135	
MLE3840								38 _{-0.050} ^{-0.025}	42 (H7) ₀ ^{+0.025}	0.025	0.135	
MLE4040	MLE4050							40 _{-0.050} ^{-0.025}	44 (H7) ₀ ^{+0.025}	0.025	0.135	
MLE4540	MLE4550							45 _{-0.050} ^{-0.025}	50 (H7) ₀ ^{+0.025}	0.025	0.155	
MLE5040	MLE5050	MLE5060		MLE5080				50 _{-0.050} ^{-0.025}	55 (H7) ₀ ^{+0.030}	0.025	0.160	
MLE5540		MLE5560						55 _{-0.055} ^{-0.025}	60 (H7) ₀ ^{+0.030}	0.025	0.165	
MLE6040	MLE6050	MLE6060	MLE6070					60 _{-0.055} ^{-0.025}	65 (H7) ₀ ^{+0.030}	0.025	0.165	
MLE6540	MLE6550	MLE6560	MLE6570					65 _{+0.005} ^{+0.035}	70 (H7) ₀ ^{+0.030}	0.025	0.185	
MLE7040	MLE7050	MLE7060		MLE7080				70 _{+0.005} ^{+0.035}	75 (H7) ₀ ^{+0.030}	0.025	0.185	
MLE7540	MLE7550	MLE7560		MLE7580				75 _{+0.005} ^{+0.035}	80 (H7) ₀ ^{+0.030}	0.025	0.185	
MLE8040	MLE8050	MLE8060		MLE8080				80 _{+0.005} ^{+0.035}	85 (H7) ₀ ^{+0.035}	0.025	0.190	
MLE8540	MLE8550	MLE8560		MLE8580				85 ₀ ^{+0.035}	90 (H7) ₀ ^{+0.035}	0.025	0.195	
MLE9040	MLE9050	MLE9060			MLE9090			90 ₀ ^{+0.035}	95 (H7) ₀ ^{+0.035}	0.025	0.195	
MLE9540								95 ₀ ^{+0.035}	100 (H7) ₀ ^{+0.035}	0.025	0.195	
MLE10040	MLE10050		MLE10070			MLE10095		100 ₀ ^{+0.035}	105 (H7) ₀ ^{+0.035}	0.025	0.195	
	MLE10550					MLE10595		105 ₀ ^{+0.035}	110 (H7) ₀ ^{+0.035}	0.025	0.195	
MLE11040	MLE11050	MLE11060	MLE11070			MLE11095		110 ₀ ^{+0.035}	115 (H7) ₀ ^{+0.035}	0.025	0.195	
MLE12040	MLE12050		MLE12070			MLE12095		120 ₀ ^{+0.035}	125 (H7) ₀ ^{+0.040}	0.025	0.200	
	MLE13050			MLE13080				130 _{-0.005} ^{+0.035}	135 (H7) ₀ ^{+0.040}	0.025	0.205	
	MLE14050		MLE14070	MLE14080			MLE140100	140 _{-0.005} ^{+0.035}	145 (H7) ₀ ^{+0.040}	0.025	0.205	
MLE15040	MLE15050			MLE15080			MLE150100	150 _{-0.005} ^{+0.035}	155 (H7) ₀ ^{+0.040}	0.025	0.205	
	MLE16050			MLE16080			MLE160100	160 _{-0.005} ^{+0.035}	165 (H7) ₀ ^{+0.040}	0.025	0.205	

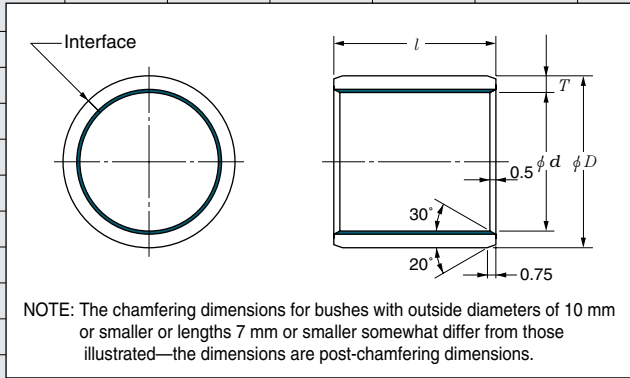

9. Dimension table for MLEF bearings

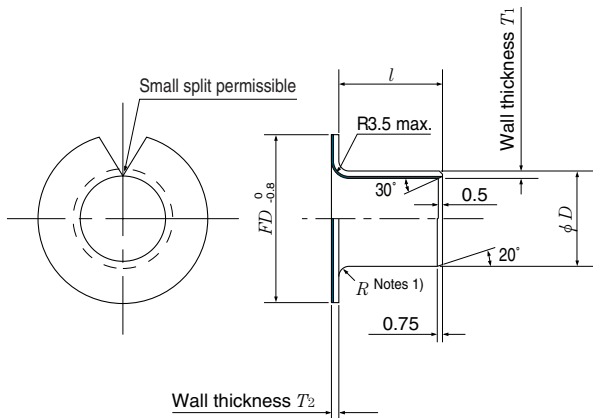

Notes

1. Dimension R in the above diagram is 0.75 or smaller when the wall thickness $T_1 = 1.0$, and 1.0 or smaller when the wall thickness $T_1 = 1.5$ or greater.
2. The chamfering dimensions for bushes with outside dia. 10 mm or smaller or lengths 7 mm or smaller somewhat differ from those illustrated—the dimensions are post-chamfering dimensions.

▼ Indication of Serial Number

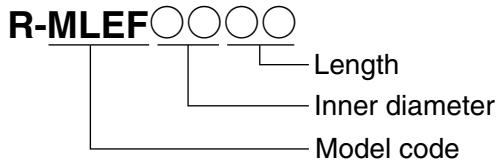

Inner diameter d	Outer diameter D	Flange O.D. FD	Length L ⁰ _{-0.4}						
			4	5	6	7	8	10	
5	7	10	MLEF0504	MLEF0505					
6	8	12		MLEF0605	MLEF0606	MLEF0607	MLEF0608	MLEF0610	
7	9	13							
8	10	15			MLEF0806		MLEF0808	MLEF0810	
10	12	18			MLEF1006		MLEF1008	MLEF1010	
12	14	20			MLEF1206		MLEF1208	MLEF1210	
14	16	22						MLEF1410	
15	17	23						MLEF1510	
16	18	24						MLEF1610	
18	20	26						MLEF1810	
20	23	31						MLEF2010	
22	25	33						MLEF2210	
24	27	35							
25	28	36							MLEF2510
26	30	38							
28	32	40							
30	34	42							
31	35	45							
32	36	46							
35	39	49							
38	42	52							
40	44	54							
45	50	60							
50	55	65							
55	60	70							
60	65	75							

10. Dimension table for MLEW bearings

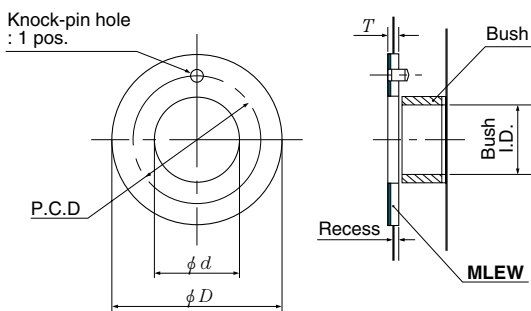

▼ Indication of Serial Number

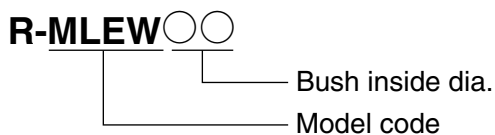

I.D. of bush used with MLEW	Model number	Inner diameter d mm	Outer diameter D mm	Wall thickness T mm
6	MLEW06	8 ^{+0.25} ₀	16 ⁰ _{-0.25}	1.5 ^{-0.03} _{-0.08}
8	MLEW08	10 ^{+0.25} ₀	18 ⁰ _{-0.25}	1.5 ^{-0.03} _{-0.08}
10	MLEW10	12 ^{+0.25} ₀	24 ⁰ _{-0.25}	1.5 ^{-0.03} _{-0.08}
12	MLEW12	14 ^{+0.25} ₀	26 ⁰ _{-0.25}	1.5 ^{-0.03} _{-0.08}
14	MLEW14	16 ^{+0.25} ₀	30 ⁰ _{-0.25}	1.5 ^{-0.03} _{-0.08}
16	MLEW16	18 ^{+0.25} ₀	32 ⁰ _{-0.25}	1.5 ^{-0.03} _{-0.08}
18	MLEW18	20 ^{+0.25} ₀	36 ⁰ _{-0.25}	1.5 ^{-0.03} _{-0.08}
20	MLEW20	22 ^{+0.25} ₀	38 ⁰ _{-0.25}	1.5 ^{-0.03} _{-0.08}
22	MLEW22	24 ^{+0.25} ₀	42 ⁰ _{-0.25}	1.5 ^{-0.03} _{-0.08}
24	MLEW24	26 ^{+0.25} ₀	44 ⁰ _{-0.25}	1.5 ^{-0.03} _{-0.08}
25	MLEW25	28 ^{+0.25} ₀	48 ⁰ _{-0.25}	1.5 ^{-0.03} _{-0.08}
30	MLEW30	32 ^{+0.25} ₀	54 ⁰ _{-0.25}	1.5 ^{-0.03} _{-0.08}
35	MLEW35	38 ^{+0.25} ₀	62 ⁰ _{-0.25}	1.5 ^{-0.03} _{-0.08}
40	MLEW40	42 ^{+0.25} ₀	66 ⁰ _{-0.25}	1.5 ^{-0.03} _{-0.08}
45	MLEW45	48 ^{+0.25} ₀	74 ⁰ _{-0.25}	2.0 ^{-0.03} _{-0.08}
50	MLEW50	52 ^{+0.25} ₀	78 ⁰ _{-0.25}	2.0 ^{-0.03} _{-0.08}

Dimensions to be measured at 25°C / Unit in mm

Length $L_{-0.4}^0$								Wall thickness		Recommended dimensions		Installed clearance (When installed to H7 cemented carbide housing)	
12	15	20	25	30	40	50	60	T_1	T_2	Shaft	H7 Housing	Min.	Max.
								$1.0_{-0.025}^0$	$1.0_{-0.2}^0$	5 $_{-0.037}^{-0.025}$	7 (H7) $_{0}^{+0.015}$	0.025	0.102
										6 $_{-0.037}^{-0.025}$	8 (H7) $_{0}^{+0.015}$	0.025	0.102
MLEF0712										7 $_{-0.040}^{-0.025}$	9 (H7) $_{0}^{+0.015}$	0.025	0.105
MLEF0812										8 $_{-0.040}^{-0.025}$	10 (H7) $_{0}^{+0.015}$	0.025	0.105
MLEF1012	MLEF1015									10 $_{-0.040}^{-0.025}$	12 (H7) $_{0}^{+0.018}$	0.025	0.108
MLEF1212	MLEF1215	MLEF1220								12 $_{-0.043}^{-0.025}$	14 (H7) $_{0}^{+0.018}$	0.025	0.111
MLEF1412	MLEF1415	MLEF1420								14 $_{-0.043}^{-0.025}$	16 (H7) $_{0}^{+0.018}$	0.025	0.111
MLEF1512	MLEF1515	MLEF1520	MLEF1525							15 $_{-0.043}^{-0.025}$	17 (H7) $_{0}^{+0.018}$	0.025	0.111
MLEF1612	MLEF1615	MLEF1620	MLEF1625							16 $_{-0.043}^{-0.025}$	18 (H7) $_{0}^{+0.018}$	0.025	0.111
MLEF1812	MLEF1815	MLEF1820	MLEF1825							18 $_{-0.043}^{-0.025}$	20 (H7) $_{0}^{+0.021}$	0.025	0.114
MLEF2012	MLEF2015	MLEF2020	MLEF2025	MLEF2030				$1.5_{-0.030}^0$	$1.5_{-0.2}^0$	20 $_{-0.046}^{-0.025}$	23 (H7) $_{0}^{+0.021}$	0.025	0.127
MLEF2212	MLEF2215	MLEF2220	MLEF2225							22 $_{-0.046}^{-0.025}$	25 (H7) $_{0}^{+0.021}$	0.025	0.127
				MLEF2430						24 $_{-0.046}^{-0.025}$	27 (H7) $_{0}^{+0.021}$	0.025	0.127
MLEF2512	MLEF2515	MLEF2520	MLEF2525	MLEF2530						25 $_{-0.046}^{-0.025}$	28 (H7) $_{0}^{+0.021}$	0.025	0.127
	MLEF2615	MLEF2620								26 $_{-0.046}^{-0.025}$	30 (H7) $_{0}^{+0.021}$	0.025	0.127
				MLEF2830						28 $_{-0.046}^{-0.025}$	32 (H7) $_{0}^{+0.025}$	0.025	0.131
MLEF3012	MLEF3015	MLEF3020	MLEF3025	MLEF3030	MLEF3040					30 $_{-0.046}^{-0.025}$	34 (H7) $_{0}^{+0.025}$	0.025	0.131
			MLEF3125							31 $_{-0.050}^{-0.025}$	35 (H7) $_{0}^{+0.025}$	0.025	0.135
				MLEF3230						32 $_{-0.050}^{-0.025}$	36 (H7) $_{0}^{+0.025}$	0.025	0.135
MLEF3512		MLEF3520	MLEF3525	MLEF3530	MLEF3540	MLEF3550				35 $_{-0.050}^{-0.025}$	39 (H7) $_{0}^{+0.025}$	0.025	0.135
					MLEF3840			38 $_{-0.050}^{-0.025}$	42 (H7) $_{0}^{+0.025}$	0.025	0.135		
MLEF4012		MLEF4020		MLEF4030	MLEF4040	MLEF4050		40 $_{-0.050}^{-0.025}$	44 (H7) $_{0}^{+0.025}$	0.025	0.135		
			MLEF4525		MLEF4540	MLEF4550		$2.5_{-0.040}^0$	$2.5_{-0.3}^0$	45 $_{-0.050}^{-0.025}$	50 (H7) $_{0}^{+0.025}$	0.025	0.155
		MLEF5020		MLEF5030	MLEF5040		MLEF5060			50 $_{-0.050}^{-0.025}$	55 (H7) $_{0}^{+0.030}$	0.025	0.160
							MLEF5560			55 $_{-0.055}^{-0.025}$	60 (H7) $_{0}^{+0.030}$	0.025	0.165
				MLEF6030	MLEF6040		MLEF6060			60 $_{-0.055}^{-0.025}$	65 (H7) $_{0}^{+0.030}$	0.025	0.165

Dimensions to be measured at 25°C / Unit in mm

Knock-pin hole dia. mm	P.C.D at knock-pin location mm	Depth of recess in housing mm
1.100~1.300	12 ±0.12	0.95~1.20
1.100~1.300	14 ±0.12	0.95~1.20
1.625~1.875	18 ±0.12	0.95~1.20
2.125~2.375	20 ±0.12	0.95~1.20
2.125~2.375	23 ±0.12	0.95~1.20
2.125~2.375	25 ±0.12	0.95~1.20
3.125~3.375	28 ±0.12	0.95~1.20
3.125~3.375	30 ±0.12	0.95~1.20
3.125~3.375	33 ±0.12	0.95~1.20
3.125~3.375	35 ±0.12	0.95~1.20
4.125~4.375	38 ±0.12	0.95~1.20
4.125~4.375	43 ±0.12	0.95~1.20
4.125~4.375	50 ±0.12	0.95~1.20
4.125~4.375	54 ±0.12	0.95~1.20
4.125~4.375	61 ±0.12	1.45~1.70
4.125~4.375	65 ±0.12	1.45~1.70