

For New Technology Network

NTN[®]

NTN corporation

Bearings with solid grease

Patent pending

CAT. NO. 3022-III/E

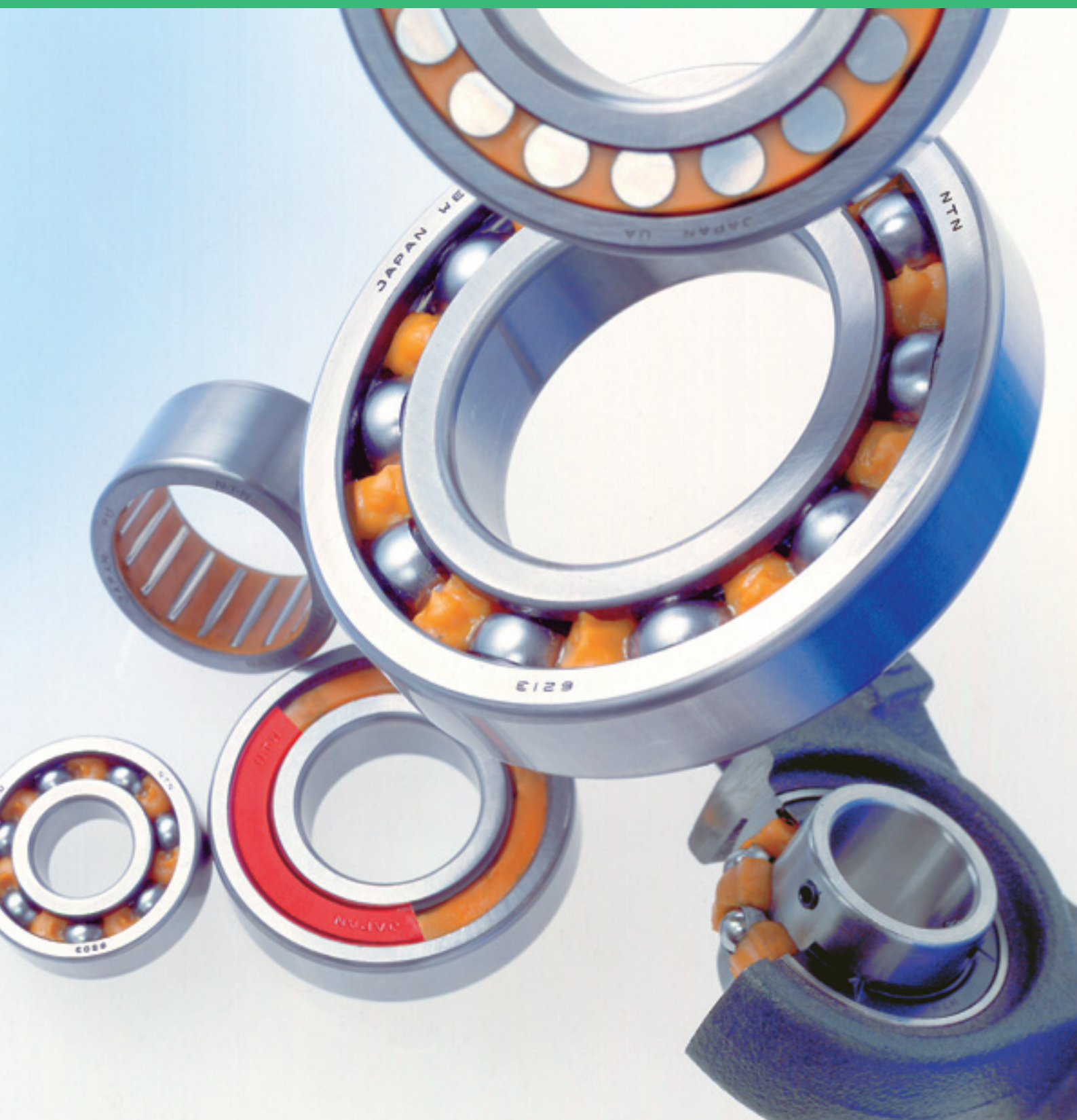

NTN

BEARINGS with SOLID GREASE

Bearings with general-purpose solid grease

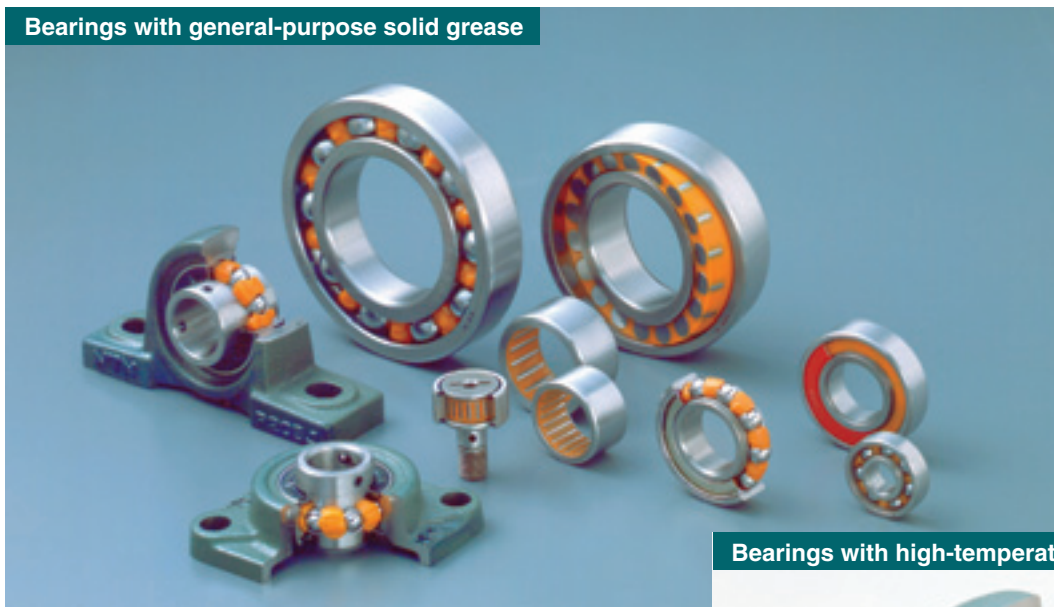

Bearings with high-temperature solid grease



Bearings with food-grade solid grease



Overview

"Solid grease" is a lubricant essentially composed of lubricating grease and ultra-high polymer polyethylene. Solid grease has the same viscosity as ordinary grease at normal temperature, but as a result of a special heat treatment process, this grease solidifies retaining a large proportion of the lubricant in it. Thanks to this solidification, the grease does not easily leak from the bearing, even when the bearing is subjected to strong vibrations or centrifugal force, helping to extend bearing life.

Bearings with solid grease are available in two types: the spot-pack type in which solid grease is injected into the retainer, and the full-pack type in which all empty space around the rolling elements is filled with solid grease. Spot-pack solid grease is standard for deep groove ball bearings, small diameter ball bearings, and bearing units. Full-pack solid grease is standard for self-aligning ball bearings, self-aligning roller bearings, and needle roller bearings.

Table 1 Major components in solid greases

Solid grease (code)	Resin	Lubricant
General-purpose solid grease (LP03)	Ultra-high polymer polyethylene ^①	Li-mineral oil grease
High-temperature solid grease (LP05)	Epoxy silicone resin	Urea-synthetic oil grease
Food-grade solid grease (LP06)	Ultra-high polymer polyethylene ^①	Urea-liquid paraffin mineral oil grease ^②

^① Conforms to FDA standard.

^② Conforms to H-1 standard of USDA.

● Solid grease filling options



Deep groove ball bearings (spot-pack)



Bearing units (spot-pack)

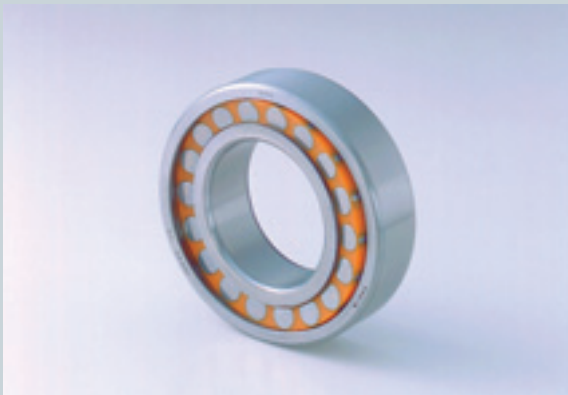

Spherical roller bearings (full-pack)



Needle roller bearings (full-pack)

Features

1. Reduced lubricant leakage

Because the base oil is retained in a solid mixture, it is less likely to leak out of the bearing. During operation, temperature rise and/or centrifugal force will cause a gradual release of the base oil into the raceway groove. Eliminating grease leakage from the bearing ensures a consistent supply of lubricant and prevents contamination of the surrounding environment.

2. Superior lubrication

Bearings with solid grease resist grease leakage prolonging bearing life in applications where high centrifugal force or vibration are present. The solid lubricant does not emulsify when exposed to water also extending both grease and bearing life.

3. Low torque characteristics

The running torque of spot-pack bearings with solid grease is lower than that of bearings using standard lubricants. With conventional greases, a shearing resistance is created as the grease is channeled out of the raceway groove. Spot-pack bearings with solid grease do not experience shear resistance resulting in a lower running torque.

4. Sealing effect

Though solid grease protects a bearing against ingress of foreign matters (water, dust, etc.), it is not a sufficient means as a sealing device. Therefore, for applications that need reliable sealing performance, we recommend the use of contact type rubber seals (deep groove ball bearings, bearing units) or other seals (other bearing types).

1 Availability

1. Bearings with general-purpose solid grease (LP03)

Table 2 (○:standard △:special ×:not available)

Bearing ③	Type		Bearing size Bearing out. dia.
	Spot-pack	Full-pack	
Deep groove ball bearings	○ ①	△	Up to 250 mm dia.
Miniature bearings Small dia. ball bearings	○ ①	×	Inside diameter from 6 to 9 mm
Self-aligning ball bearings	×	○ ①	Up to 250 mm dia.
Spherical roller bearings	×	○ ①	Up to 250 mm dia.
Bearing units	○ ①	△	Up to 300 mm dia.
Needle roller bearings	×	○ ②	Note ②

① Deep groove ball bearings with spot-pack configuration and ZZ shields are standard. Certain types and sizes of standard bearings listed in the table above are not available with solid grease. For further information, consult NTN Engineering by specifying the intended bearing type and size.

② Available bearing size for needle roller bearings varies depending on bearing type. For further information, contact NTN Engineering.

Note: The bearing components are not composed of a corrosion-proof material.

2. Spot-pack configuration for bearings with high-temperature solid grease (LP05)

For the available bearing sizes for deep groove ball bearings and bearing units, consult NTN Engineering.

3. Spot-pack configuration for bearings with food-grade solid grease (LP06)

F-UC204D1 to F-UC210D1

(Bearing units-stainless steel series)

Stainless steel deep groove ball bearings ① (bearing outside diameter 250 mm or less)

The maximum operating temperature on the outer ring of bearings with solid grease must fall within the ranges in **Table 3** below.

The bearings with solid grease may be assembled by "shrink fit" technique. However, be absolutely sure that the maximum heating temperature does not exceed 100°C, the heating time is shorter than 2 hours, and the bearing does not turn during the shrink fit process.

Table 3

	Bearings with general-purpose solid grease (LP03)	Bearings with high-temperature solid grease (LP05)	Bearings with food-grade solid grease (LP06)
Allowable temperature range	-20°C~80°C (Long-time operation: 60°C or less)	-20°C~120°C (Long-time operation: 100°C or less)	-10°C~100°C (Long-time operation: 80°C or less)

Table 4 Allowable speed for bearings with solid grease

Bearing type	Load type	Allowable speed (d_n value) ①				
		general-purpose		high-temperature	food-grade	
		Spot-pack	Full-pack	Spot-pack	Spot-pack	Full-pack
Deep groove ball bearings	Radial load	20×10 ⁴	5×10 ⁴	12×10 ⁴ ③	10×10 ⁴ ④	5×10 ⁴ ④
Miniature bearings Small dia. ball bearings	Radial load	20×10 ⁴	—	—	—	—
Self-aligning ball bearings	Radial load	—	3×10 ⁴	—	—	—
Spherical roller bearings	Radial load	—	3×10 ⁴	—	—	—
	Axial load/radial load ≤ 0.3	—	2×10 ⁴	—	—	—
Bearing units	Radial load	12×10 ⁴	3×10 ⁴	8×10 ⁴	10×10 ⁴	—
Needle roller bearings	Radial load	—	3×10 ⁴ ②	—	—	—

① d_n value: (d = bearing bore dia. [mm]) × (n = service speed [rpm])

② $F_w \cdot n$ value: (F_w = roller set bore dia. [mm]) × (n = service speed [rpm])

③ 8×10⁴ for contact seal type.

④ If intending a speed exceeding an allowable speed, consult NTN Engineering.

A minimum radial load is required to prevent skidding of the rolling elements when using full-pack solid grease. The minimum load required is approximately 1% of the bearing dynamic load rating.

Please consult NTN for further details.

2 Allowable Temperature Range

3 Allowable Speed

4 Minimum Required Load

(1) Lubricant Leakage Test

Non shielded/sealed test bearings (spot-pack) were subjected to a centrifugal acceleration of 3,000 G (5,000 rpm) for a period of four hours. Lubricant leakage from the NTN bearings with solid grease was approximately 2.0% by weight for the horizontally mounted condition, and approximately 5.0% by weight for the vertically mounted condition.

(Standard grease filled bearings using contact (LU) and non-contact (LB) seals were also subjected to the above test. Within ten minutes after starting the test, centrifugal force caused the seals to become displaced allowing the grease to expel.)

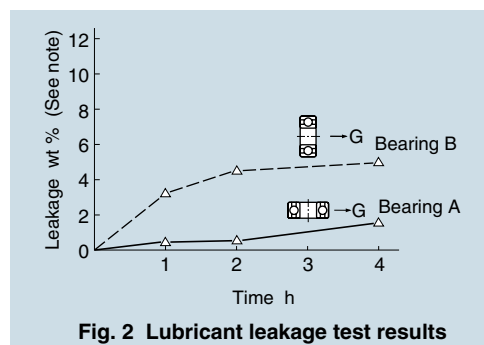
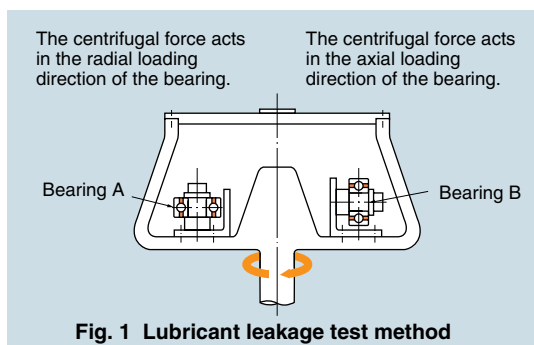

Note) Leakage: weight ratio of leaked lubricant compared to the amount (100%) of NTN Solid grease filled

Table 5 Lubricant leakage test conditions

	Bearing A	Bearing B
Test pieces	6201(Solid grease, spot-pack, open) 6201LLU(lithium mineral oil grease, contact type rubber seal) 6201LLB(lithium mineral oil grease, non-contact type rubber seal)	
Centrifugal acceleration	3,000 G (5,000 rpm)	
Bearing speed	Static	
Bearing fixing	The centrifugal force acts in the radial loading direction of the bearing.	The centrifugal force acts in the axial loading direction of the bearing.
Test time	4 hours : The bearings were weighed every hour and lubricant leakage (weight ratio) was determined.	

(2) Rotating Torque Test

When tested, the required rotating torque level for NTN bearings with solid grease utilizing the spot-pack configuration was found to be less than bearings using lithium-diester grease (an acknowledged low torque grease). However, the full-pack configuration exhibited running torque levels greater than those of standard bearings.

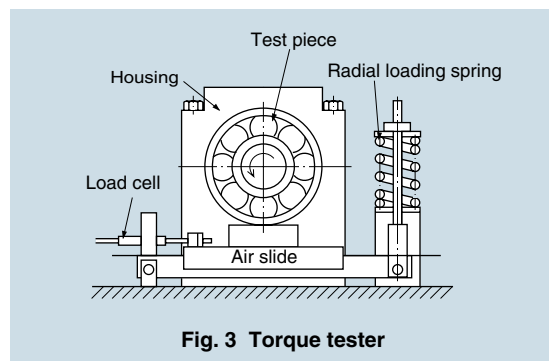

Table 6 Torque testing conditions

	Testing conditions
Test piece	6204ZZ
Test grease	LP03 and Li greases (30% fill relative to the bearing space capacity, other than for LP03 full-pack configuration)
Bearing load	Radial load; 39 N {4 kgf}
Bearing speed	1,800, 3,600, 7,200 rpm
Measuring method	Measured after rotating torque was stabilized

Table 7 Torque test results

		unit $\times 10^{-4} \text{Nm}$		
Speed (rpm)		1800	3600	7200
Li-mineral oil grease		230	385	550
Li-polyol-ester-grease		145	265	383
Li-diester grease		90	315	403
Solid grease	Spot-pack	63	113	190
	Full-pack	340	—	—

(3) Rotating Torque Test (LP03, LP05)

The running torque with LP05 was tested using the torque tester in Fig. 4, under the test conditions in Table 8. The test results are plotted in Fig. 5. The running torque with LP05 is equivalent to that with LP03.

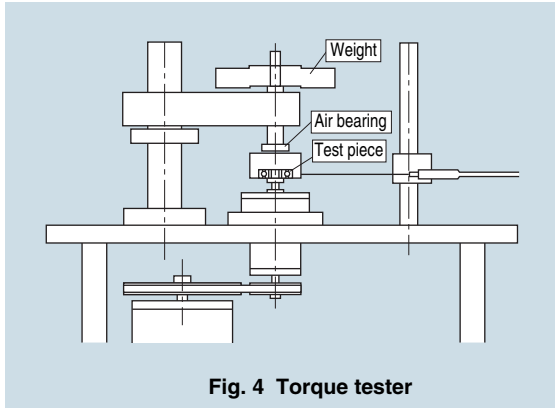

Fig. 4 Torque tester

Table 8 Torque testing conditions

Testing conditions	
Test piece	6204LLB
Test grease	LP03 (spot-pack configuration) LP05 (spot-pack configuration)
Bearing load	Axial load; 39 N {4 kgf}
Bearing speed	1000, 2000, 3000, 4000, 5000, 6000, 7000, 8000 rpm

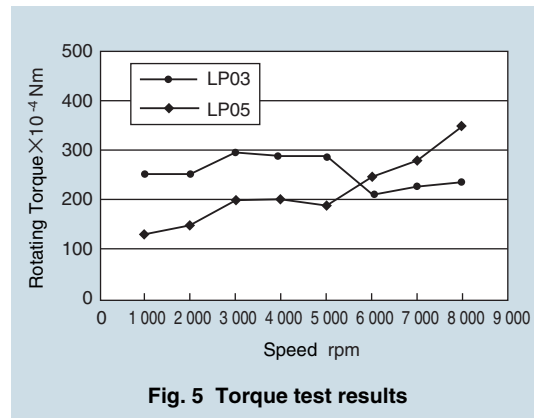

Fig. 5 Torque test results

(4) Salt Water Test

A salt water endurance test was performed to compare the performance of bearings with solid grease to that of bearings using a conventional lubricant (lithium-mineral oil based grease). As noted in Table 9, NTN bearings with solid grease were found to out perform standard bearings although some surface deterioration had been detected.

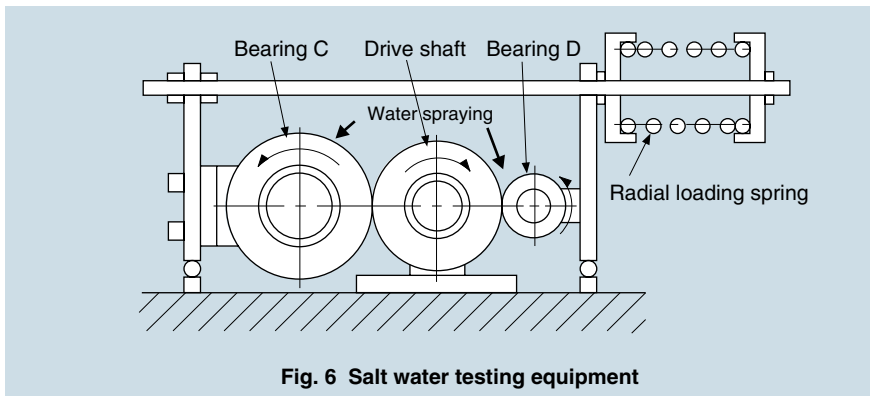

Fig. 6 Salt water testing equipment

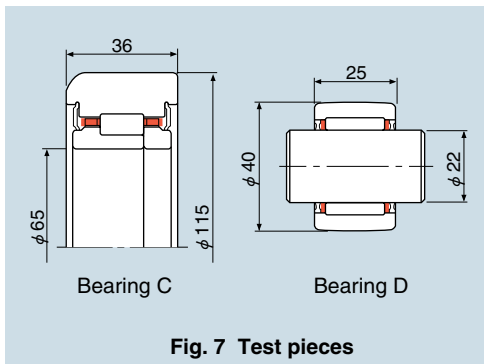

Fig. 7 Test pieces

Table 9 Salt water testing conditions

	Bearing C	Bearing D
Bearing load	157 N {16 kgf}	
Bearing speed	50 rpm (outer ring)	144 rpm (outer ring)
Volume of sprayed water	9 lit./min.	
Salt concentration	5.0% wt.	
Operating cycle	Total running time 500 h. (5 hour run + 5 hour break) × 62 cycles	

Table 10 Salt water test results

	Solid grease		Li-mineral oil grease	
	Brg. C	Brg. D	Brg. C	Brg. D
Rotating condition (ease of hand rotation)	△	△	×	×
Amount of lubricant remaining	○	○	×	×
Lubricant deterioration	△	△	×	×
Water invasion resistance	○	○	×	×

Test results= ○: good △: fair (some deterioration detected) ×: poor

6 Stainless steel series prelubricated deep groove ball bearings

1. Product overview

(1) Having an inner ring, outer ring, and retainer each made of a stainless steel, this unique series of contact seal type deep groove ball bearings have a spot-pack configuration with solid grease (LP03).

(2) Bearing accuracy

The dimensional accuracy and running accuracy of this series of bearings are equivalent to JIS class 0 bearings.

(3) Radial internal clearance

The permissible radial internal clearances of this bearing series are summarized in the table below. Note that the values in this table differ from those specified in the JIS (Japanese Industrial Standard) standard.

Nominal bore diameter mm		Radial internal clearance	
over	incl.	min	max
—	10	6	17
10	18	6	20
18	30	8	22

(4) The indications on the inner and outer rings are as listed below.

• SSN 0 series

Designation	Indication	
	Inner ring	Outer ring
SSN000LL	SS	SS
SSN001LL	SS	SS
SSN002LL	SS	SS
SSN003LL	SS	SMT, SS6003, JAPAN
SSN004LL	SS	SMT, SS6004, JAPAN
SSN005LL	SS	SMT, SS6005, JAPAN
SSN006LL	SS	SMT, SS6006, JAPAN

• SSN 2 series

Designation	Indication	
	Inner ring	Outer ring
SSN200LL	SS	SMT, SS6200, JAPAN
SSN201LL	SS	SMT, SS6201, JAPAN
SSN202LL	SS	SMT, SS6202, JAPAN
SSN203LL	SS	SMT, SS6203, JAPAN
SSN204LL	SS	SMT, SS6204, JAPAN
SSN205LL	SS	SMT, SS6205, JAPAN
SSN206LL	SMT, 6206RS, JAPAN	SS

2. Dimension table

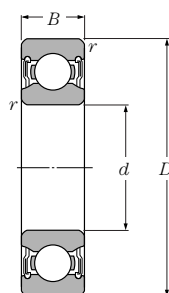

Contact seal type

Boundary dimensions mm				Basic load ratings				Bearing number	Optional ^② (Basic number)
d	D	B	r's min ^①	dynamic Cr	static Cor	dynamic Cr	static Cor		
10	26	8	0.3	3.5	1.96	360	200	SSN000LL/LP03	6000
	30	9	0.6	3.95	2.39	400	244	SSN200LL/LP03	6200
12	28	8	0.3	3.95	2.39	400	244	SSN001LL/LP03	6001
	32	10	0.6	5.25	3.05	535	310	SSN201LL/LP03	6201
15	32	9	0.3	4.30	2.86	440	291	SSN002LL/LP03	6002
	35	11	0.6	5.85	3.75	600	380	SSN202LL/LP03	6202
17	35	10	0.3	4.60	3.25	470	330	SSN003LL/LP03	6003
	40	12	0.6	7.35	4.80	750	490	SSN203LL/LP03	6203
20	42	12	0.6	7.20	5.05	735	515	SSN004LL/LP03	6004
	47	14	1	9.90	6.65	1 010	680	SSN204LL/LP03	6204
25	47	12	0.6	7.75	5.85	790	595	SSN005LL/LP03	6005
	52	15	1	10.8	7.85	1 100	800	SSN205LL/LP03	6205
30	55	13	1	10.2	8.25	1 040	845	SSN006LL/LP03	6006
	62	16	1	15.0	11.3	1 530	1 150	SSN206LL/LP03	6206

^① Smallest allowable dimension for chamfer dimension r.

^② The dimensions with listed basic numbers are identical to the boundary dimensions in JIS B 1512.

Fan blower support bearing

Lubricant suction prevention

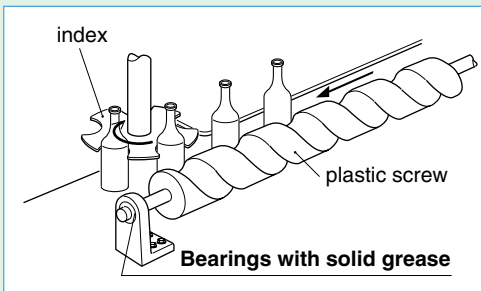
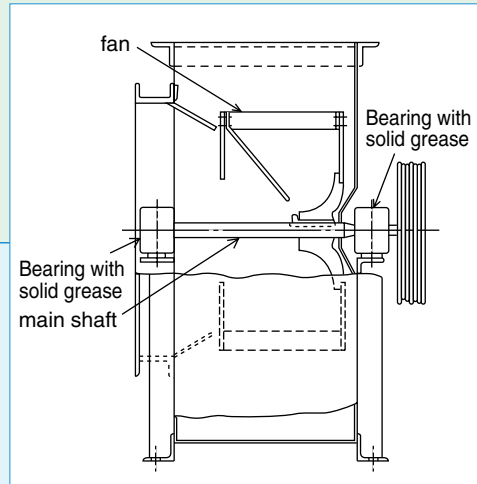
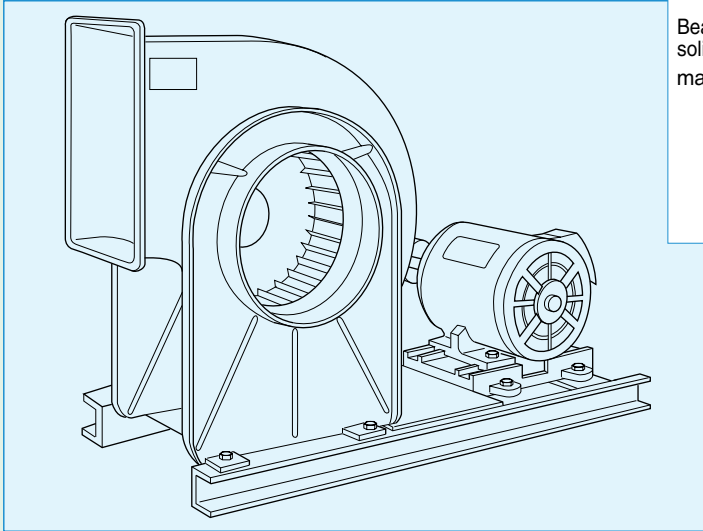

Support bearings for bottle feeder of filler on bottling line

Prevention of lubricant leakage and product contamination

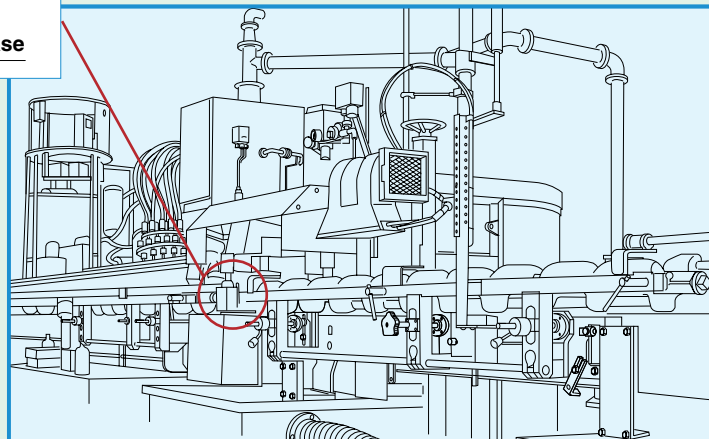

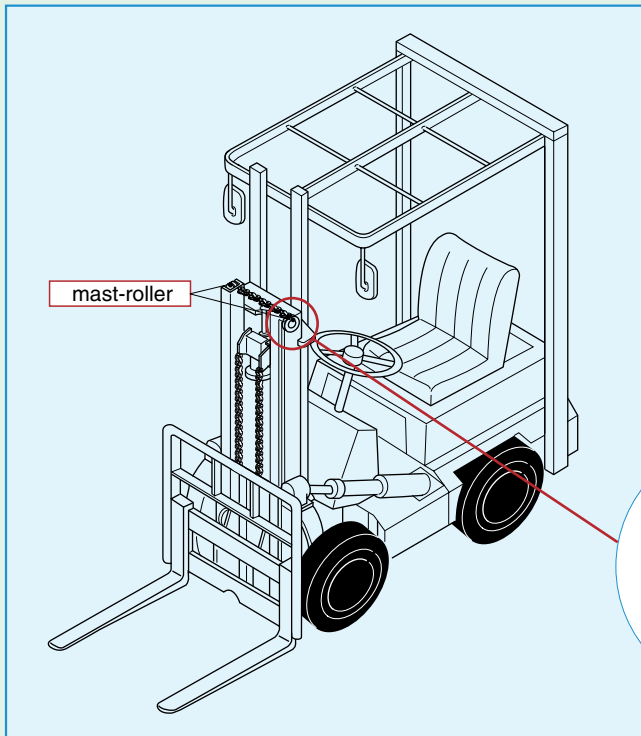

mast-roller

Forklift mast-roller

Prevention of lubricant emulsification and grease leakage. Prolonged bearing life.

Bearings with solid grease

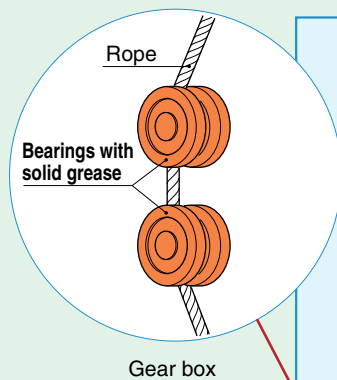
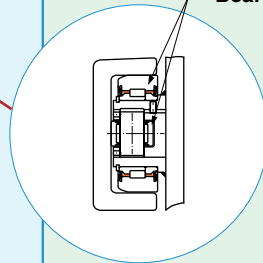

Rope

Bearings with solid grease

Gear box

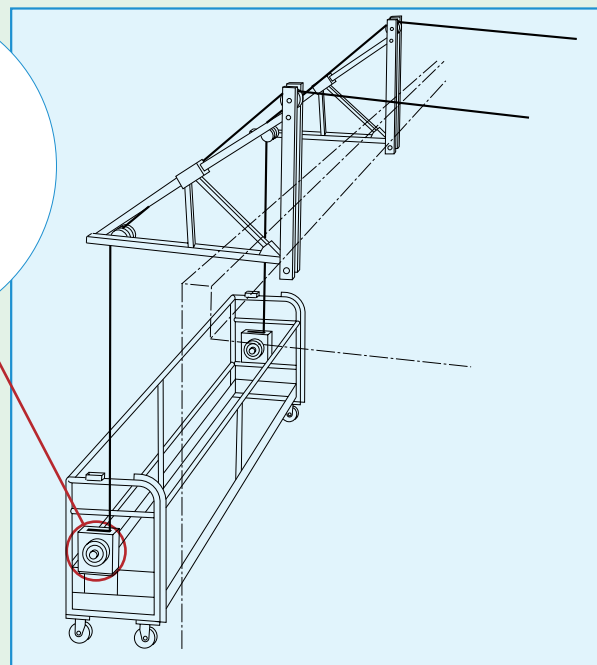

Guide roller for gondola rope

Prevention of lubricant emulsification and grease leakage. Prolonged maintenance period.

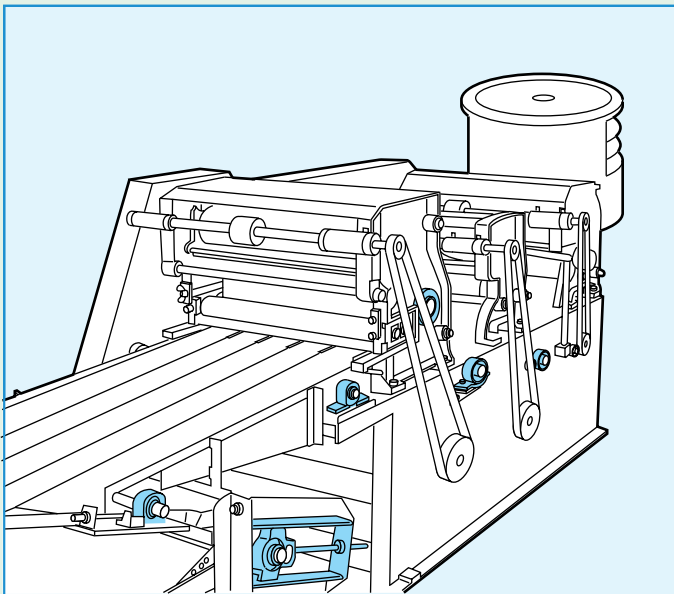

Noodle-making machine



Automatic wonton skin making lines

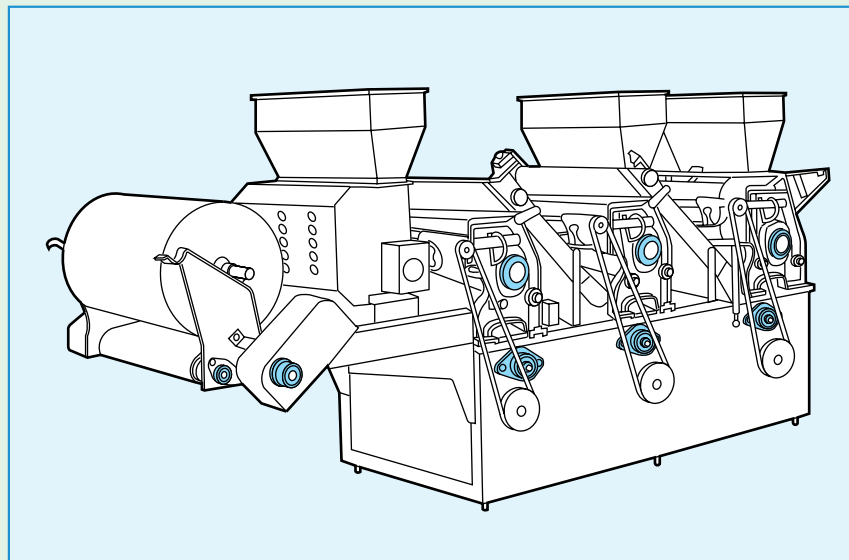

Table 11 Typical applications

Machines	Required characteristics
Cranes, sheaves, conveyors, steel mill rollers, amusement machines, etc.	Bearings with long lubricant life
Fork lift truck mast rollers, conveyors, etc.	Improved dust and water-proofing capability
Wire stranding machines etc.	Prevention of lubricant leakage (i.e. applications where the bearing is required to rotate about an axis other than its own).
Printing presses, office equipment, textile machines, food processing machines, etc.	Prevention of leaked lubricant (clean work environment)
Testing equipment, film stretching machines, etc.	Low torque

CAUTIONS: Avoid use in presence of splashing organic solvent (acetone, benzene, kerosene, etc.)