





« Providing you with a complete range of tools and services for your bearings, adapted to your application, size and resources »

Experts
& Tools

NTN-SNR Experts & Tools, working to serve our customers.

Every customer has specific expectations in terms of bearing maintenance and lubrication, therefore NTN-SNR Experts & Tools offers solutions designed for your application and priorities, not forgetting budget.

Every application requires specific expertise. Wind turbine maintenance differs from press or crusher maintenance. NTN-SNR is able to provide the expertise and tools you need thanks to almost one century of theory and practice in everyday contact with industrial applications.

Our recommendations will be based on the scale and difficulty of your maintenance and lubrication operations of your units. We provide customised solutions in terms of tools or organisation depending on your situation.

With nearly 18,000 employees working throughout the world, NTN-SNR prepares and improves maintenance methods and tools on a daily basis. Our aim is to provide easy-to-implement products and services. When we design our tools and organise our services, we aim to improve your effectiveness. From reducing the duration of maintenance and servicing operations to optimising the life cycle of your bearings, our services can lead to real benefits, improve safety and extend service lives.

This catalogue includes our full range of greases, automatic Lubricator and centralised lubrication systems, plus our related services. Our maintenance tools are listed in a separate catalogue. (See opposite)



LUB'SOLUTIONS, let us solve your lubrication problems

All bearings, mechanical parts and industrial processes need reliable and suitable lubrication to operate in an optimal and long-term manner. In addition to supplying quality bearings, NTN-SNR is aware of the critical nature of lubrication for your applications, and can provide its expertise and products to manage this fundamental issue.

The LUB'SOLUTIONS product range includes lubricants specially selected for various applications, and all items you may need to reliably distribute and apply just the right amount of lubricant each mechanical part requires.

However, **LUB'SOLUTIONS is above all a team of experts** ready to assist you in implementing the right solutions for your environment. Our technicians are available to solve your problems, from providing advice in defining your requirements to installing lubrication systems for your application, including made-to-measure projects.

LUB'SOLUTIONS, the Experts & Tools way of thinking. Our experts are available and determined to provide you with customised solutions to ensure that your bearings and machines operate in optimal conditions, applying their Experts & Tools way of thinking.

GENERAL CONTENTS

P. 5 1 - LUBRICANTS

- Grease or oils and your choice - 06



P. 15 2 - SINGLE-POINT LUBRICATION

- Manual lubrication : grease or oil gun - 16
- Automatic lubrication :
 - READY Booster - 18*
 - SMART Booster - 20*
 - DRIVE Booster - 22*
 - Accessories for the Booster range - 24*



P. 27 3 - CENTRALISED LUBRICATION SYSTEMS

- Choosing the right technology - 28
- LUB'SOLUTIONS products:
 - Volumetric lubrication - 34*
 - Progressive lubrication - 36*
 - Multi-line lubrication - 38*
 - Dual-line lubrication - 38*
 - Air-oil lubrication - 39*
 - Circulating lubrication systems - 40*
 - Flow control products and accessories - 40*



P. 41 4 - LUBRICATION THEORY AND METHODS

- Product interchanges for replacement - 42
- LUB'SOLUTIONS services - 43
- Lubrication requirement design tools - 44

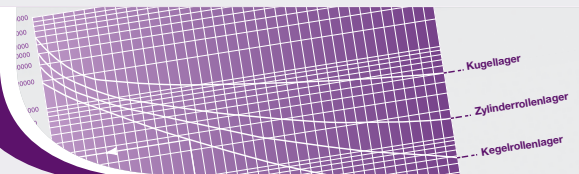

P. 47 5 - PRODUCT TECHNICAL DATA





Lubricants : Grease or oils and your choice

P. 6

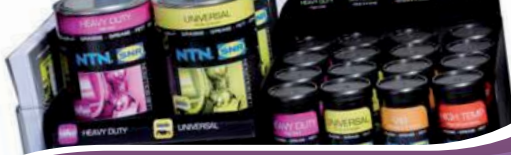

1 - LUBRICANTS

WHAT THE EXPERTS SAY:

Only appropriate lubrication can guarantee the optimal operation of bearings and the related mechanical assembly.

55% of premature bearing failure is caused by inappropriate lubrication.

Inadequate lubrication will substantially shorten the service life of the bearing. Bearing lubrication is often neglected due to the difficulty of accessing bearings and the operator's lack of lubricant knowledge.

Selecting the right lubricant, the right lubrication method, the precise quantity required for the bearing and the frequency of monitoring the lubrication are all critical points.

A - PRINCIPLE AND BENEFITS OF GOOD LUBRICATION

- A film of lubricant (oil film) between the balls or rollers and the bearing raceway prevents **wear and seizure**.
- Lubrication protects components **from corrosion**
- Lubrication also protects the components **from liquids** and external pollution, and evacuates wear debris.
- Lubrication reduces **friction**, reducing the power consumed by the machine, and thereby providing **energy savings**.
- Circulating oil distributes heat and contributes to the thermal equilibrium of the machine.

The service life of the bearing is directly related to the effectiveness of the oil film, which depends on:

- the type of lubricant; its specific heat capacity, resistance to vibrations, etc.
- the load and speed of the bearing.

Greases for general use do not always meet the specific requirements of some applications. Bearings requested to operate in specific load, speed or temperature conditions, or in the presence of water, humidity or vibrations, require the use of carefully selected grease.

NTN-SNR has carried out research in this field with the leading international lubricant manufacturers for more than half a century.

We therefore have knowledge and practical experience for most lubricants used with bearings.

B - SELECTING YOUR TYPE OF LUBRICATION

	OIL LUBRICATION	GREASE LUBRICATION
ADVANTAGES	<ul style="list-style-type: none"> • Good penetration into the bearing • Good physical and chemical stability • Cooling • Easy lubricant control: volume and level 	<ul style="list-style-type: none"> • Clean mechanisms • Simplified sealing • Protection • Simple assembly • Easy handling • Reduced or no lubricant replacement required • Option to use pre-greased bearings
DISADVANTAGES	<ul style="list-style-type: none"> • Sealing required for assembly • Inadequate protection against corrosion and humidity in case of extended periods of non-running • Time delay, if it is necessary to start independent circulation prior to rotation of the bearing 	<ul style="list-style-type: none"> • Higher friction coefficient than oil • Reduced heat transfer • The bearing must be dismantled and washed in order to be replaced (if necessary) • No option to check the level of grease, therefore grease levels must be reliable or periodic top-up is required to compensate for leaks, pollution and aging

C - GREASE CHARACTERISTICS

Grease is a product with a semi-fluid to solid consistency, obtained by blending a thickening agent (soap) with a liquid lubricant (mineral or synthetic oil).

Additives may be included to obtain specific properties. The growing use of grease-lubricated bearings, combined with the development of 'greased for life' lubrication, makes grease a critical element in the bearing. The service life of the bearing and its behaviour in various environments significantly depends on the properties of the grease used.

Physical and chemical characteristics:

Consistency

- NLGI (National Lubrication Grease Institute) grades correspond to a value of worked penetration in the grease (according to test specification ASTM/D217)
- For bearings, the consistency generally adopted is grade 2 (normal).

Viscosity of basic oil: generally defined in cSt (mm²/S) at 40°C.

Density: approx. 0.9

Drop point: the temperature at which the first drop of a sample liquefied by heating drips

Approximately: 180°C/260°C depending on the composition of the grease. The maximum service temperature of the grease is always well below the drop point.

NLGI GRADES	WORKED PENETRATION	CONSISTENCY
0 1	385 - 355 340 - 310	Semi-fluid Very soft
2 3	295 - 265 250 - 220	Soft Normal
4	205 - 175	Firm

Functional characteristics

The working conditions imposed on the lubricant (rolling, mixing) require special greases for bearings which cannot be selected simply on the basis of their physical and chemical characteristics.

The NTN-SNR Research and Test Centre is continuously testing to approve bearings, enabling us to offer advice on the most suitable grease for each application.

Approval specifications are based on the following criteria:

- endurance for ball bearings
- endurance for roller bearings
- water resistance
- resistance to high and low temperatures
- adhesion (centrifugation)
- resistance to vibrations (false brinelling)
- resistance to high speeds
- etc.

Other criteria can be added depending on the final results required by the customer. Selecting a type of grease will represent the best compromise based on the specifications for the application.

D - TECHNICAL CHARACTERISTICS OF LUBRICANTS AND MAKING A CHOICE

The grease will be selected on the basis of operating conditions, which must be defined as precisely as possible: temperature, speed, load, environment, vibrations and any other specific limitations inherent to the application.

Select which grease to use with the assistance of your NTN-SNR contact.

The table on the pages 12 & 13 provides initial guidance

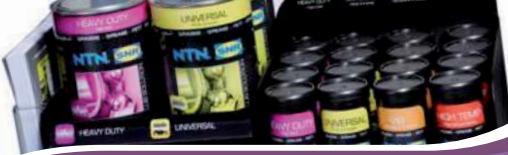

1-LUBRICANTS



UNIVERSAL Multi purpose



Grease for general usage, in industry or for automobiles ▶ 10

○ **STANDARD APPLICATIONS**

Agricultural equipment, washing machines, handling equipment, general mechanical devices, low-power electric motors, car wheel bearings, small tools, etc

○ **BENEFITS**

Good properties in the presence of water, excellent protection against wear and corrosion

○ **TEMPERATURE RANGE**

from -25°C to +140°C



HEAVY DUTY High Load



Top quality grease for very high-pressure applications, suitable for many applications, intended for arduous applications in heavy industry: metallurgy, construction, transport, etc. ▶ 10

○ **STANDARD APPLICATIONS**

Conveyors, lifting devices, truck wheel hubs, high-power electric motors, water pumps, presses, etc.

○ **BENEFITS**

Excellent performance under heavy loads, including at high speeds, good properties in the presence of water, excellent protection against wear and corrosion.

○ **TEMPERATURE RANGE**

from -25°C to +140°C



VIB Vibrations & Shocks



This grease is an ideal lubricant for parts subjected to extensive vibrations or impact. Recommended for quarries, cement plants, public works and agricultural operations, high-load applications in humid environments, paper plants, boring, etc. ▶ 11

○ **STANDARD APPLICATIONS**

Shafts in scoops, crushers, grinders, vibrating scalpels, washing machines, industrial fans, etc.

○ **BENEFITS**

Excellent resistance to impact, vibrations and heavy loads, excellent resistance to water guaranteeing long-term lubrication.

○ **TEMPERATURE RANGE**

from -20°C to +140°C



HIGH TEMP High temperature



This grease is the ideal solution for long-term lubrication at high temperatures up to +150°C. Accepts occasional peaks at +175°C. ▶ 11

○ **STANDARD APPLICATIONS**

Textile machines, paper transformation machines, hot fans, dryers, tensioning rollers, vehicle water pumps, etc.

○ **BENEFITS**

Extremely long resistance to high temperatures, excellent protection against wear and corrosion, for ball and roller bearings, for horizontal and vertical shafts.

○ **TEMPERATURE RANGE**

from -40°C to +160°C



FOOD AL Food Sure

Multi-purpose grease for the food and pharmaceutical industries. Complies with NSF-H1* recommendations*

▶ 11



STANDARD APPLICATIONS

At any point where accidental contact with food is technically possible. Bottling machines, dairy equipment, industrial baking, pasta manufacturing, confectionery, slaughterhouses, etc.

BENEFITS

Wide range of service temperatures, good protection against corrosion, good resistance to washing with hot and cold water, and many disinfectant solutions and detergents.

TEMPERATURE RANGE

from -25°C to +120°C

* NSF: National Sanitation Foundation /H1: Occasional contact with food



CHAIN OIL

Synthetic oil for high-temperature chains

▶ 11



STANDARD APPLICATIONS

Textile and plastic injection machines: in levelling equipment, stenter frames, multi-layer systems, festoon dryers, festoon steamers and coating units.

For all types of stenter chains lubricated with oil (roller chains, clips with ball bearings, sliding with guide bars) and chain/chain shaft articulations.

BENEFITS

Excellent lubrication, even with the presence of high temperatures and loads, excellent spreading properties, ensuring the rapid formation of a film of lubrication, excellent resistance to loads and wear, good adhesion therefore no spray, little formation of residue thanks to 100% synthetic components.

TEMPERATURE RANGE

from -20°C to +250°C

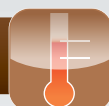

ULTRA HIGH TEMP - Extreme High Temperature

This grease is for long-term lubrication for any type of bearing subjected to extreme temperatures

▶ 11



STANDARD APPLICATIONS

Textile drying machines, corrugated board production units, the plastic industry, rolling tail pipes, copy machines, furnace equipment, kiln cars, electric motors operating at extreme temperatures, etc.

BENEFITS

For very high service temperatures up to +260°C, good ability to absorb pressure, excellent resistance to aggressive agents, compatible with most plastics and seals.

TEMPERATURE RANGE

from -30°C to +260°C



HIGH SPEED + Spindles

Low-temperature grease for very high speeds

▶ 11



STANDARD APPLICATIONS

Textile machine spindles, spindles in power-operated tools running at high speeds (milling shafts, lathes, grinders, drills, etc.)

BENEFITS

Reduced running-in time for spindle bearings, excellent resistance to water (protects against the premature failure of bearings and reduces maintenance costs), reduced bearing temperature due to low friction torque (extended bearing service life), synthetic oil + low-viscosity ester ensuring a wide range of service temperatures and excellent cold temperature resistance

TEMPERATURE RANGE

from -45°C to +120°C

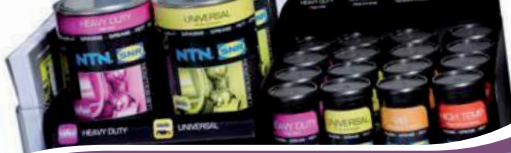

1-LUBRICANTS

GREASE CHARACTERISTICS

(physical, chemical and mechanical properties, packaging)

Lubricants: description	UNIVERSAL	UNIVERSAL +	HEAVY DUTY	HEAVY DUTY +
NLGI consistency grade	2	2	2	2
Base oil	Mineral	Mineral	Mineral	Mineral
Thickener / type of soap	Lithium	Lithium /Calcium	Lithium with EP additives	Lithium with EP additives
Colour	Amber	Brun clair	Amber	Brown
Base oil viscosity (cSt) - at 40°C	115	220	115	150
	- at 100°C	11	6,5	15
Service temperature range (°C)	From -25 to +140°C	From - 30 to +130	From -25 to +140°C	From -30 to +150°C
Drop point (°C) DIN ISO2176	> 190	> 170	> 190	> 190
Suitable for medium loads P<C/5		+		++
Suitable for high loads P<C/5		-		++
Suitable for low speeds n.Dm <100,000		+		+
Suitable for high speeds n.Dm >100,000		+		+
Properties in humid environments, in the presence of water		++		++
Suitable for low-amplitude oscillations		+		+
Suitable for vibrations when shutdown		-		-
Adhesion		+		+
Low torque		+		+
Low noise levels		+		+
Anti-corrosion protection		++		++
Resistance to chemical agents		-		-
Pumpability		++		++
Sizes available	400 g cartridge 1 kg can 5 kg bucket 23 & 50 kg drums	Lubricator BOOSTER	400 g cartridge 1 kg can 5 kg bucket 23, 50 and 190 kg drums	Lubricator BOOSTER
Remarks	Previous name: MS		Previous name: EP	

N.Dm: rpm x mean diameter (millimetres)

- ++ : Excellent performance
- + : Good performance
- : Not recommended
- / : Not applicable

HIGH TEMP	VIB	FOOD AL	ULTRA HIGH TEMP	HIGH SPEED +	CHAIN OIL
2	2	2	2	2	
Semi-synthetic	Semi-synthetic	Paraffinic mineral	Perfluorinated polyether synthetic	Ester + SHC	Ester + PAO
Polyurea	Lithium /Calcium	Aluminium complex	PTFE	Lithium /Calcium	
Light Brown	Light Brown	Pale yellow	White	Light brown	Pale green
160	360	248	420	25	320 (*)
18	25	24	40	5,8	28 (*)
From -40 to +160°C	From -20 to +140°C	From - 25 to +120	From -30 to +260°C	From -45 to +120°C	From -20 to +250°C
> 250	> 190	> 200	Not measurable (*)	> 180	-25
+	+	+	++	+	/
-	++	+	++ (**)	-	/
+	++	+	++	-	/
+	-	+	+	++	/
+	+	+	+	++	/
++	++	+	++	+	/
-	-	-	-	++	/
++	++	+	++	+	/
+	-	+	-	++	/
+	-	-	-	++	/
+	+	+	+	++	/
-	-	-	++	-	/
++	++	++	++	++	/
400 g cartridge 1 kg can Lubricator BOOSTER	400 g cartridge 1 kg can 50 kg drum Lubricator BOOSTER	400 g cartridge 1 kg can Lubricator BOOSTER	800 g cartridge	1 kg can	READY and SMART BOOSTER
Previous name: HT	Previous name: VX	- Meets NSF requirements as an H1 product	* According to standard DIN 2176, the drop point of this grease cannot be determined, i.e. this grease fails to melt **If T<200°C	Pay attention to quantity, and grease levels	*Base oil viscosity at 20°C = 1200cSt

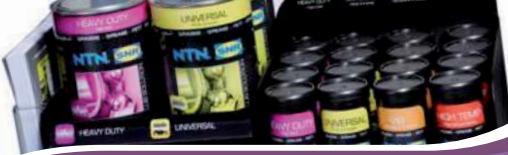

1-LUBRICANTS

E - SELECTING AN NTN-SNR GREASE SUITABLE FOR YOUR APPLICATIONS

PREVAILING OPERATION	OPERATING LIMITS		EXAMPLES OF APPLICATIONS
	TEMPERATURE °C	SPEED	
General usage	-25 to +130	< maximum bearing speed	Industry and automobile: Agricultural equipment, general mechanical devices, handling equipment, electrical tools, car wheel bearings, etc.
High loads	-25 to +140	< 2/ 3 maximum bearing speed	Arduous applications in heavy industry: Iron and steel, construction, transport, conveyors, lifting devices, high-power electric motors, water pumps, presses, truck wheel hubs, etc.
High temperature	-40 to +160	< 2/ 3 maximum bearing speed	Textile machines, paper transformation machines, hot fans, dryers, tensioning rollers, vehicle water pumps, etc.
	-30 to +260	< 2/ 3 maximum bearing speed	Corrugated board production, the plastic industry, textile drying machines, rolling tail pipes, copy machines. Electric motors operating at very high temperatures, furnace equipment, kiln cars, etc.
Low temperature	Until - 45	< 2/ 3 maximum bearing speed	Aviation, special devices.
High speed	-20 to +120	< 4/ 3 maximum bearing speed	Machine tool spindles, textile machine spindles, miniature electric motors
Humidity	-30 to +120	< 2/ 3 maximum bearing speed	Washing machines
High-amplitude impacts or vibrations Centrifugation Rotating outer ring	-20 to +130	< 2/ 3 maximum bearing speed	For quarries, cement plants, public works and agricultural operations, high-load applications in humid environments, paper plants, drilling and boring Shafts in scoops, crushers, grinders, vibrating scalpels, washing machines, industrial fans, etc.
Food usage	-25 to +120	< 2/ 3 maximum bearing speed	Applications where accidental contact with food is technically possible: Bottling machines, dairy equipment, industrial baking, pasta manufacturing, confectionery, slaughterhouses, etc
High-temperature chain oil	-20 to +250		Applications in the textile and plastics industries with all types of oil-lubricated chains: Levelling machines, stenter frames, multi-layer systems, festoon steamers, dryers, coating units.

TYPICAL RECOMMENDATIONS	EXPERTS & TOOLS RECOMMENDATIONS
Mineral oil Traditional soap (lithium, calcium, etc.) Grade 2 consistency is generally used for large bearings or bearings with specific operating properties. Reduced performance above 90°C (continuous).	UNIVERSAL or UNIVERSAL +
Similar to general purpose greases with extreme pressure additives	HEAVY DUTY or HEAVY DUTY +
Polyurea thickener with highly viscous or semi-synthetic mineral base oil. Important: greases with silicon base oil have reduced resistance when subjected to high loads.	HIGH TEMP
100% synthetic grease Important: greases with silicon base oil have reduced resistance when subject to high loads	ULTRA HIGH TEMP
Base oil with very low viscosity Important: the grease becomes fluid if temperature >80°C	HIGH SPEED +
Oil with very low viscosity	
Traditional grease doped with anti-corrosion additive	UNIVERSAL or HEAVY DUTY (normal or +)
Grease with grade 2 consistency and high adhesion	VIB
Meets NSF requirements as an H1 product *NSF: National Sanitation Foundation /H1: Occasional contact with food	FOOD AL
Oil with good adhesion and good creep properties (spreading)	CHAIN OIL



1-LUBRICANTS

GREASE COMPATIBILITY

It is not generally advised to mix two lubricating greases.

If two greases are mixed (e.g.: when grease is changed in a lubrication system), check the compatibility of the two greases, i.e. of their base oils and their thickeners.

OIL	MINERAL	PAO POLY ALPHA-OLEFIN	ESTER	P. POLY GLYCOL	POLYPHENYL ETHER	SILICONE (METHYL)	SILICONE (PHENYL)	FLUORINATED
MINERAL	C							
PAO POLY ALPHA-OLEFIN	C	C						
ESTER	C	C	C					
P. POLY GLYCOL	NC	NC	C	C				
POLYPHENYL ETHER	C	C	C	NC	C			
SILICONE (METHYL)	NC	NC	NC	NC	NC	C		
SILICONE (PHENYL)	C	C	C	NC	C	C	C	
FLUORINATED	NC	NC	NC	NC	NC	NC	NC	C

Legend : C : Compatible - NC - Not Compatible

THICKENER	ANHYDROUS CALCIUM SOAP	CALCIUM COMPLEX SOAP	LITHIUM SOAP	LITHIUM COMPLEX SOAP	LITHIUM / CALCIUM SOAP	ALUMINIUM COMPLEX SOAP	BENTONE SILICA GEL	POLYUREA	FLUORINATED
ANHYDROUS CALCIUM SOAP	C								
CALCIUM COMPLEX SOAP	NC	C							
LITHIUM SOAP	C	NC	C						
LITHIUM COMPLEX SOAP	C	C	C	C					
LITHIUM / CALCIUM SOAP	C	NC	C	C	C				
ALUMINIUM COMPLEX SOAP	C	NC	NC	NC	NC	C			
BENTONE SILICA GEL	C	NC	NC	NC	NC	NC	C		
POLYUREA	C	C	C	C	NC	C	NC	C	
FLUORINATED	NC	NC	NC	NC	NC	NC	NC	NC	C

Legend : C : Compatible - NC - Not Compatible

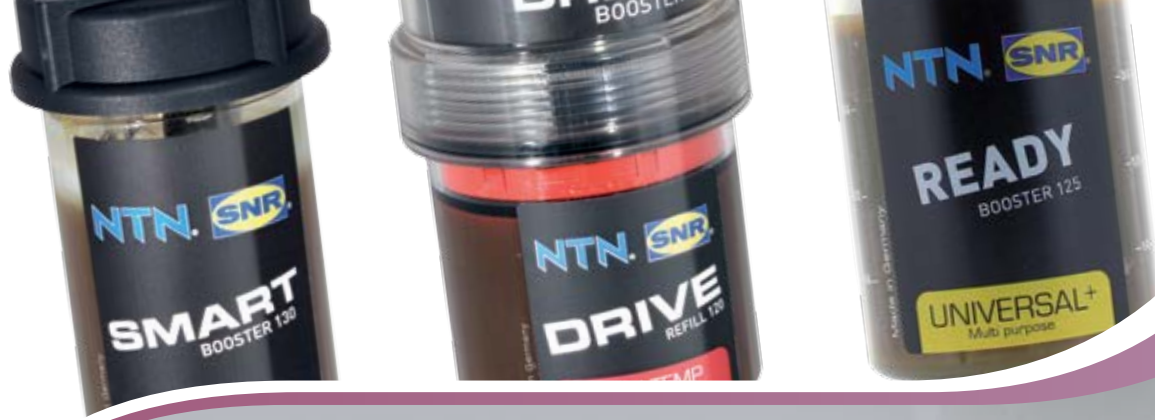

Single-point lubrication

P. 16

Manual lubrication: grease or oil gun P. 16

Automatic lubrication:

READY Booster P. 18

SMART Booster P. 20

DRIVE Booster P. 22

Accessories for the Booster range P. 24

MANUAL

GREASE OR OIL GUN

Easy one-handed lubrication

48



*Optional

APPLICATIONS

The grease gun is the ideal tool for easy, clean and quick greasing in industrial and agricultural environments.

BENEFITS

- **Practical**
The pump can be operated with one hand
Easy grip thanks to the knurled casing
Can be used either with cartridges or filled directly with grease.
- **Robust**
Designed for industrial applications with a maximum pressure of 345 bars.
The high quality impact-proof steel guarantees long-life.
- **Clean and precise application**
The special grease nozzle developed by NTN-SNR can be screwed to the grease gun.
Use this nozzle to inject grease cleanly and precisely into the bearing.
Slow and controlled grease flow: 0.5 cm³ /travel

PRODUCT NAME

LUB GREASE GUN SET

Cap (in optional): LUB GREASE GUN/ACC SET

AUTOMATIC

WHAT THE EXPERTS THINK

Reduce your maintenance times and operating costs while improving safety for your personnel and machines.

The automatic Lubricator can be used to ensure the constant and regular lubrication of your bearings. The Lubricator is easy to integrate into various applications (mechanical and automobile industries, steelworks, paper plants, etc.), and can be used to optimise lubrication without any need to modify your Installations.

AUTOMATIC LUBRICATORS CAN BE USED TO ACHIEVE CONTINUOUS, RELIABLE, CLEAN AND EXTREMELY PRECISE LUBRICATION FOR YOUR BEARINGS:

- They provide a constant and controlled supply of quality grease, 24 hours a day, 7 days a week.
 - > **Less friction = energy savings**
- They actively contribute to extending the service cycle of the bearings.
 - > **They improve the reliability of industrial equipment**
- They eliminate the risk of excessive or inadequate lubrication
- They reduce the risk of contamination
- They guarantee the right lubrication with the right grease
 - > **Reducing the number of premature failures**
- They can be used to extend mean time between maintenance operations on the machine
 - > **Reducing the risks of accidents, particularly in dangerous or difficult-to-access areas**

CHOOSE THE MOST APPROPRIATE AUTOMATIC LUBRICATOR AND GREASE FOR YOUR APPLICATIONS



UNIVERSAL +



HEAVY DUTY +



VIB



HIGH TEMP



FOOD

DESCRIPTION

General purpose grease for industrial use

Suitable for very high loads, compatible with many applications, intended for arduous applications

Parts subject to extensive vibrations or impact. For high-load applications in humid environments.

This grease is ideal for long-term lubrication at high temperatures up to +150°C. Accepts peaks of +175°C

Multi-purpose grease for the food and pharmaceutical industries. Complies with NSF-H1 recommendations

APPLICATIONS

Agricultural equipment, handling equipment, general mechanical devices, low-power electric motors, etc.

Heavy industry: metallurgy, construction, transport, conveyors, lifting devices, water pumps, etc.

Quarries, cement works, public works and humid environments: paper works, boring, crushers, vibrating scalpers, etc.

Textile machines, paper transformation machines, hot fans, dryers, water pumps, etc.

Bottling machines, dairy equipment, industrial baking, pasta manufacturing, confectionery, slaughterhouses, etc.

TECHNICAL DATA

Soap	Lithium Calcium	Lithium	Lithium Calcium	Polyurea	Aluminium complex
Oil	Mineral	Mineral	Semi-synthetic	Semi-synthetic	Paraffinic mineral
Service temperature	-25°C/+130°C	-30°C/+150°C	-20°C/+140°C	-40°C/+160°C	-30°C/+120°C
Viscosity at 40°C	100 cSt	150 cSt	360 cSt	160 cSt	195 cSt

PRODUCT RANGE

READY Booster	•	•	•	•	•
SMART Booster	•	•	•	•	•
DRIVE Booster	•	•	•	•	•



ECO BOOSTER

- 125 cm³
- Low-cost
- Robust
- Ergonomic: excellent grease level visibility
- Can be used in explosive areas



SMART BOOSTER

- + capacity: 130 cm³
- Precise, ergonomic
- Adjustable discharge (in months) using an LCD
- Constant flow, regardless of ambient temperature
- Recyclable: re-usable control unit
- Suitable for explosive areas



DRIVE BOOSTER

- Polyvalent
- 2 sizes: 120 cm³ and 250 cm³
- Multi-purpose
- Precise
- Powerful: suitable for remote lubrication
- Rechargeable

* For lubrication using CHAIN OIL, refer to the following pages, describing each Automatic Lubricator in detail.



1 / READY BOOSTER 125



This system is ideal for humid environments, exposed to corrosive environment or requiring optimised hygiene standards, just like in the food industry.



READY BOOSTER: robust and cost effective model

A • DESCRIPTION

This model is suitable for a wide range of applications, particularly for arduous environments which could cause corrosion in electronic systems, or in industrial sectors with high demands in terms of cleanliness and hygiene.



The grease is pressurised by an inert gas generated by an electrochemical reaction. The duration of the distribution for the 125 cm³ of grease is adjustable from 1 to 12 months thanks to a selector.

B • APPLICATIONS

Designed for the single-point lubrication of plain or rolling element type bearings, open gears, chains, ball screws, linear guide bars, etc. The units resistance to corrosion makes it very popular in the food industry.



C • CHARACTERISTICS AND BENEFITS

<ul style="list-style-type: none"> • Compact design (flange optional) 	<ul style="list-style-type: none"> • Easy to install, even in confined locations
<ul style="list-style-type: none"> • Certification   II 1G Ex ia IIC T6 II 1D Ex iaD 20 T85°C I M1 Ex ia I DEKRA 13 ATEX 0078 X 	<ul style="list-style-type: none"> • Can be used in explosive areas
<ul style="list-style-type: none"> • Transparent tank in high density polyamide 	<ul style="list-style-type: none"> • Easy to check grease level
<ul style="list-style-type: none"> • Watertight and dustproof 	<ul style="list-style-type: none"> • Corrosion and vibration resistant • Can operate in all positions.
<ul style="list-style-type: none"> • Flow limiter valve integrated in the oil version 	<ul style="list-style-type: none"> • Simple installation

D • TECHNICAL DATAS

Drive: **gas-operated with an electrochemical reaction**

Capacity: **125 cm³**

Max. pressure: **5 bars**

Duration of distribution: **1 to 12 months**

Immediate start-up: **1 day**

Service temperature: **from -20°C to +60°C**

Available with advanced NTN-SNR greases, especially developed for bearings, and with special synthetic oil for chains. Contact us for other types of lubricants

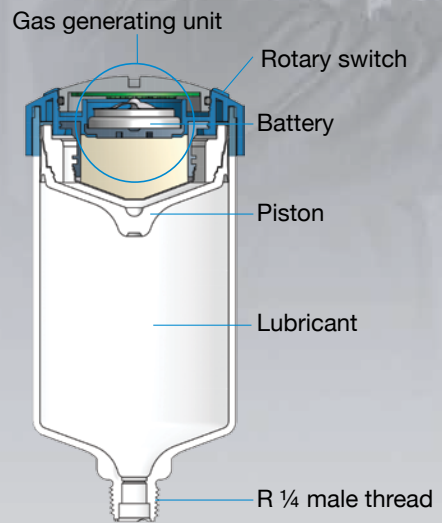

E • DESIGNATION

DESIGNATION	PRODUCT	LUBRICANT
LUBER READY UNIVERSAL +	READY BOOSTER	Grease UNIVERSAL + (General usage)
LUBER READY HEAVY DUTY +	READY BOOSTER	Grease HEAVY DUTY + (High loads)
LUBER READY HIGH TEMP	READY BOOSTER	Grease HIGH TEMP (High temperatures)
LUBER READY VIB	READY BOOSTER	Grease VIB (Vibrations and shocks)
LUBER READY FOOD	READY BOOSTER	Grease FOOD (Compatible with food contact)
LUBER READY CHAIN OIL	READY BOOSTER	Oil CHAIN OIL (High performance for chains)



2 / SMART BOOSTER 130



49

The advanced and low-cost lubrication solution, ideal for applications subject to temperature variations

SMART BOOSTER: the low-cost model whatever the temperature

A • DESCRIPTION

SMART BOOSTER, the first electrochemical Automatic Lubricator equipped with a re-usable control unit, providing measured flow independent of the ambient temperature.

Guaranteed continuous lubricant flow, with the correct volume for your application, regardless of temperature

This smart Automatic Lubricator is equipped with a temperature probe which adjusts pressure to distribute just the right amount of grease selected at start-up.

The duration of distribution is easy to adjust (from 1 to 12 months) simply by selecting the appropriate period on the control unit.

The control unit can be re-used several times, only the **130 cm³** grease cartridge requires replacement.





B • APPLICATIONS

Designed for the single-point lubrication of plain or rolling element type bearings, open gears, chains, ball screws, linear guide bars, etc. This model is ideal for environments facing substantial temperature variations (e.g: fans mounted under roofs) or requiring intrinsic safety (e.g: petrochemical industry).



C • CHARACTERISTICS AND BENEFITS

<ul style="list-style-type: none"> Adjustable between 1 and 12 months using the re-usable touchpad control unit, with an ON/OFF function. 	<ul style="list-style-type: none"> Flexible, precise and multipurpose, reducing operating costs while improving the lubrication of rotating parts.
<ul style="list-style-type: none"> Integrated temperature compensation with a wide range of service temperatures 	<ul style="list-style-type: none"> High level of reliability: controlled grease flow, unaffected by temperature for the entire duration of distribution Universal usage
<ul style="list-style-type: none"> Compact design with reinforced flange 	<ul style="list-style-type: none"> Robust, easy to install, even in confined locations
<ul style="list-style-type: none"> Certification   I M1 Ex ia I Ma II 2G Ex ia IIC T4 Gb II 2D Ex ia IIC T 135°C Db ZELM IO ATEX 0434X 	<ul style="list-style-type: none"> Can be used in explosive areas
<ul style="list-style-type: none"> Protection IP65 	<ul style="list-style-type: none"> Can be used in many dusty and humid environments
<ul style="list-style-type: none"> Transparent tank in high density polyamide 	<ul style="list-style-type: none"> Easy to check grease level Can operate in all positions.
<ul style="list-style-type: none"> Flow limiter valve integrated in the oil version 	<ul style="list-style-type: none"> Simple installation

D • TECHNICAL DATAS

Drive: **gas generating cells with electronic temperature compensation**

Capacity : **130 cm³**

Max. pressure : **6 bars**

Duration of distribution : **1, 2, 3, 12 months**

Immediate start-up: **1 day**

Service temperature: **from -20°C to +60°C**

Available with advanced NTN-SNR greases, especially developed for bearings, and with special synthetic oil for chains. Contact us for other types of lubricants

E • DESIGNATION

LUBER SMART (name of the grease) : Complete kit including: control unit + lubricant tank with gas generating cells and batteries + protective covers)

LUBER SMART REFILL (name of the grease) : Lubricant tank with gas generating cells and batteries + protective covers)

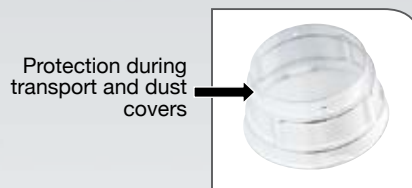
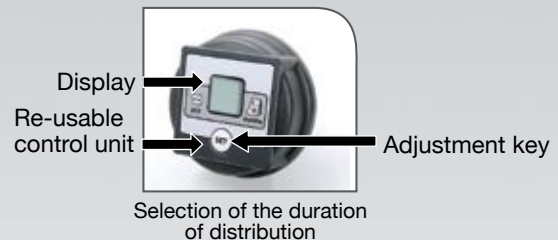
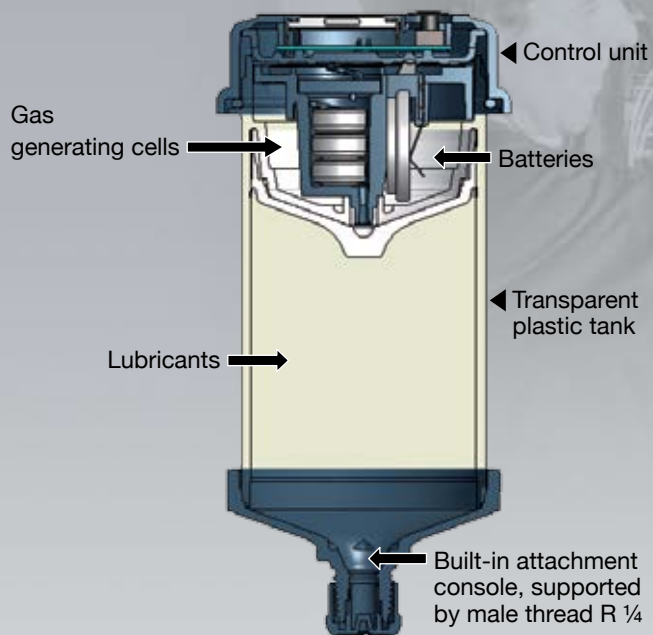

DESIGNATION	PRODUCT	LUBRICANT
LUBER SMART UNIVERSAL +	SMART BOOSTER complete	Grease UNIVERSAL + (General usage)
LUBER SMART REFILL UNIVERSAL +	Refill unit	
LUBER SMART HEAVY DUTY +	SMART BOOSTER complete	Grease HEAVY DUTY + (High loads)
LUBER SMART REFILL HEAVY DUTY +	Refill unit	
LUBER SMART HIGH TEMP	SMART BOOSTER complete	Grease HIGH TEMP (High temperatures)
LUBER SMART REFILL HIGH TEMP	Refill unit	
LUBER SMART VIB	SMART BOOSTER complete	Grease VIB (Vibrations and shocks)
LUBER SMART REFILL VIB	Refill unit	
LUBER SMART FOOD	SMART BOOSTER complete	Grease FOOD (Compatible with food contact)
LUBER SMART REFILL FOOD	Refill unit	
LUBER SMART CHAIN OIL	SMART BOOSTER complete	Oil CHAIN OIL (High performance for chains)
LUBER SMART REFILL CHAIN OIL	Refill unit	

3 / DRIVE BOOSTER 120 & 250

50

Advanced and ecological lubrication solution, designed for applications requiring highly precise dosing either in contact with the lubrication point or from a distance

DRIVE BOOSTER: the top-of-the-range model for all situations

A • DESCRIPTION

DRIVE BOOSTER, an electromechanical Automatic Lubricator for extremely precise lubrication, regardless of the temperature, with high service reliability.

Available in 2 sizes, 120 cm³ and 250 cm³, meeting the requirements of most lubrication applications.

Electromechanical drive:

- Guarantees a constant and reliable pressure of 5 bars for the entire duration of distribution
- Distances of up to 3 metres are possible for grease systems and up to 5metres for oil systems.
- Can be re-used several times, helping to protect the environment.

This is the ideal solution for lubrication in dangerous and difficult-to-access areas, and in locations subject to high ambient temperatures or severe vibrations.



B • APPLICATIONS

Designed for the single-point lubrication of plain or rolling element type bearings, open gears, chains, ball screws, linear guide bars, etc. This model is suitable for a wide range of applications and operating conditions, regardless of ambient air pressure and temperature. This model can be installed up to 3 metres from the lubrication point for grease systems and up to 5 metres for oil systems.



C • CHARACTERISTICS AND BENEFITS

<ul style="list-style-type: none"> • Robust electric motor drive • Easy adjusting 	<ul style="list-style-type: none"> • Unaffected by ambient temperature and pressure • Unaffected by vibrations • High level of reliability: constant grease flow for the entire duration of distribution
<ul style="list-style-type: none"> • Re-usable 	<ul style="list-style-type: none"> • Ecological
<ul style="list-style-type: none"> • Transparent tank in high density polyamide, with reinforced flange 	<ul style="list-style-type: none"> • Display of grease level
<ul style="list-style-type: none"> • Fitted with illuminated indicators 	<ul style="list-style-type: none"> • Indicates the operating status and can be used for quick and remote monitoring
<ul style="list-style-type: none"> • Compact design 	<ul style="list-style-type: none"> • Easy to install, even in confined locations
<ul style="list-style-type: none"> • Lubricator kit comes with all accessories 	<ul style="list-style-type: none"> • The connector set included means the Lubricator can be immediately fitted to 95% of applications
<ul style="list-style-type: none"> • Refill unit consisting of a tank of lubricant and battery pack 	<ul style="list-style-type: none"> • Service warranty

D • TECHNICAL DATAS

Drive: **electromechanical, re-usable**

Power supply: **battery pack**

Capacity: **120 cm³ or 250 cm³**

Max. pressure : **5 bars**

Duration of distribution **1, 3, 6 or 12 months**

Service temperature: **from -10°C to +50°C**

Available with advanced NTN-SNR greases especially developed for bearings. Contact us for other types of lubricants

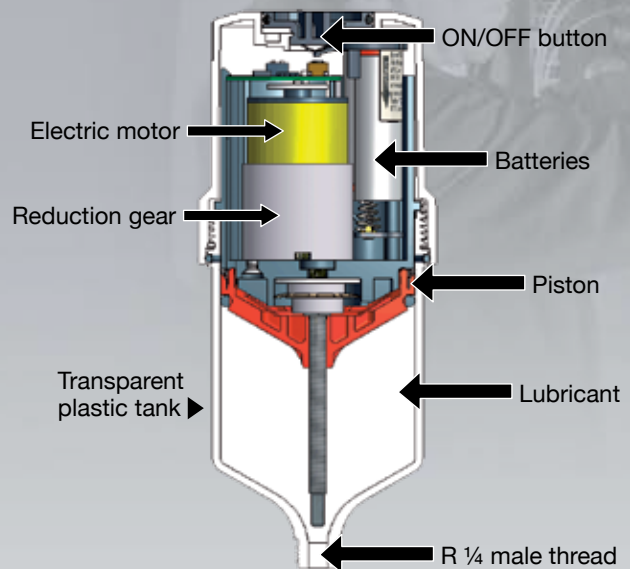

E • DESIGNATION

LUBER DRIVE KIT (capacity, grease name): Complete Automatic Lubricator kit including: Motor + 120 or 250 cm³ lubricant tank + battery pack + reinforced base + 4 reduction gear connectors.

LUBER DRIVE REFILL (capacity, grease name): Refill including: 120 or 250 cm³ lubricant tank + battery pack

The complete commercial reference is based on the same logic for other lubricants: UNIVERSAL+, HEAVY DUTY+, HIGH TEMP, VIB, FOOD.

DESIGNATION	PRODUCT	LUBRICANT
LUBER DRIVE KIT 120 UNIVERSAL +	DRIVE BOOSTER 120 kit	Grease UNIVERSAL (General usage)
LUBER DRIVE KIT 250 HEAVY DUTY +	DRIVE BOOSTER 250 kit	Grease HEAVY DUTY +
LUBER DRIVE REFILL 120 HIGH TEMP	Refill unit 120	Grease HIGH TEMP
LUBER DRIVE REFILL 250 VIB	Refill unit 250	Grease VIB

To order:

- a complete 250 cm³ DRIVE BOOSTER kit with the High Temp grease,
 - ▶ the reference is LUBER DRIVE KIT 250 HIGH TEMP
- a 120 cm³ refill with the HEAVY DUTY grease,
 - ▶ the reference is LUBER DRIVE REFILL 120 HEAVY DUTY+

4 / ACCESSORIES FOR THE BOOSTER RANGE

Select the most appropriate accessory

Support brackets:

			
DESCRIPTION	Plastic DRIVE attachment clip	Plastic SMART and READY attachment clip	support bracket + stainless steel insert
PRODUCT NAME	LUBER CLIP	LUBER CLIP SMART/READY	LUBER BRACKET

Hose connector:

	
DESCRIPTION	female connector for Booster + 1 hose (Nylon, length 1m , outer/inner dia.: 8/6 mm) + 1 G1/4 male connector
PRODUCT NAME	LUBER HOSE & CONNECTORS 1 M

Elbows:

		
DESCRIPTION	45° Elbow G1/4 - G1/4	90° Elbow G1/4 - G1/4
PRODUCT NAME	LUBER ANGLE 45 G1/4	LUBER ANGLE 90 G1/4

Adapters:

						
DESCRIPTION	Adapter G1/4 - G1/8	Adapter G1/4 - M6	Adapter G1/4 - M8 x1	Adapter G1/4 - M8 x 1.25	Adapter G1/4 - M10 x1	Adapter G1/4 - M10 x 1.5
PRODUCT NAME	LUBER REDUCER G1/4 - G1/8	LUBER REDUCER G1/4 - M6	LUBER REDUCER G1/4 - M8 x1	LUBER REDUCER G1/4 - M8	LUBER REDUCER G1/4 - M10 x1	LUBER REDUCER G1/4 - M10

Extensions:

		
DESCRIPTION	Extension R1/40 x G1/4 - 30mm	Extension R1/40 x G1/4 - 75mm
PRODUCT NAME	LUBER EXTENSION G1/4 30 mm	LUBER EXTENSION G1/4 75 mm

Brushes:

				
DESCRIPTION	Brush dia. 20 G1/4	Brush 40X30 mm G1/4	Brush 60X30 mm G1/4	Brush 100X30 mm G1/4
PRODUCT NAME	LUBER OIL BRUSH diam 20 -G1/4	LUBER OIL BRUSH 40 x 30 -G1/4	LUBER OIL BRUSH 60 x 30 -G1/4	LUBER OIL BRUSH 100 x 30 -G1/4

Drive accessories:

			
DESCRIPTION	Reinforced base G1/4 (copper / plastic)	Protection cap 120 cm ³	Protection cap 250 cm ³
PRODUCT NAME	LUBER PROTECTION BASE	LUBER PROTECTION COVER 120	LUBER PROTECTION COVER 250



Centralised lubrication systems

P. 28

Choosing the right technology P. 28

LUB'SOLUTIONS products:

Volumetric lubrication P. 34

Progressive lubrication P. 36

Multi-line lubrication P. 38

Dual-line lubrication P. 38

Air-oil lubrication P. 39

Circulating lubrication systems P. 40

Flow control products and accessories P. 40

SELECTING THE APPROPRIATE TECHNOLOGY

The 2 principles of lubrication: The lubricant is recirculated or lost

3-1 - CIRCULATING LUBRICANTS

If machine components require a large quantity of lubricant, or if it is necessary for the lubricant to be cooled or heated, a lubrication system with circulating oil should be used. In all other cases, lubricant is not recovered after lubricating the component

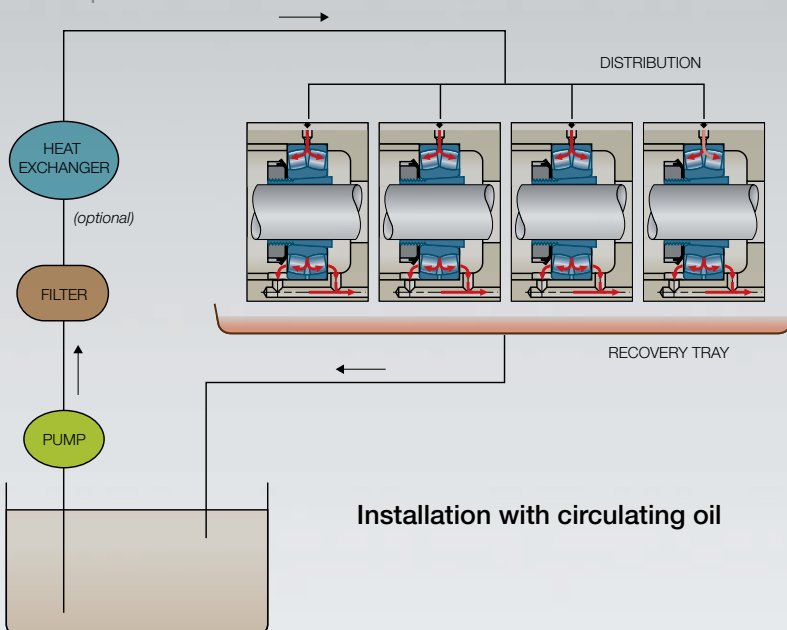

Description of the system:

Oil circulation provides continuous flow to the point requiring lubrication. Used oil is returned to the main tank and then repumped around the circuit. The pumping station can be equipped with a cooling or heating system to maintain the lubricant at an optimal temperature.

With this principle, the correct oil level is always maintained within the bearing housing. The circulation of the oil removes the heat generated and allows for higher speeds and better reliability.

The key to this type of lubrication system is the careful surveillance of the supply of lubricant.

STANDARD APPLICATIONS: paper and metal industries, gearboxes, etc.

3-2 - LOST LUBRICANT

These are the most frequently used types of centralised systems. A pump distributes small amounts of lubricant from a central tank to each lubrication point. The new lubricant replaces the old. Different methods can be used, depending on the pressure required, and based on, among other factors, pressure loss due to the viscosity of the lubricant and the varying lengths and diameters of the hoses carrying the lubricant.

Different solutions for lost lubrication

Both manual and automatic systems are available. While automatic systems require more substantial initial investment, they are more reliable and lead to long-term savings.

3-2.1 - LOST LUBRICANT WITH MANUAL SUPPLY

Centralised lubrication with manual supply

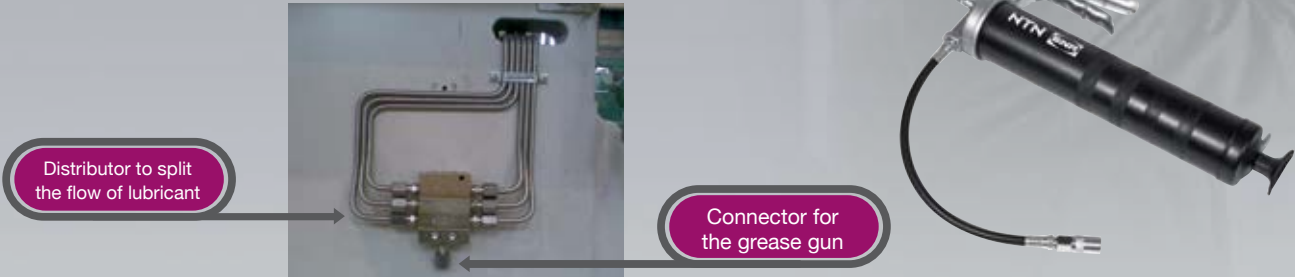

Description of the system:

All of the lubrication points are connected to a single distribution manifold with an external grease nipple. An operator connects a grease gun during scheduled maintenance and injects the recommended amount of lubricant. The distribution manifold distributes this between the individual locations. It is possible to connect a programmed pump, to inject the lubricant at regular intervals.

APPLICATIONS : Applications requiring only occasional lubrication, or applications with few locations, and which do not require a permanent pump (single machines...)

3-2.2 - LUBRICANT LOST WITH AUTOMATIC LUBRICANT SUPPLY

► Automatic volumetric lubrication (for oil or semi-liquid greases)

Description of the system:

At each cycle, the pump starts and forces the lubricant to the injector under pressure, via the main line. The injectors gradually fill. When they are full, pressure rises in the main line. A pressure switch will stop the pump when the max pressure threshold is reached.

The amount of lubricant accumulated in the injectors is discharged to the lubrication point just before or after the pump cuts out, depending on the type of injector used (direct or indirect):

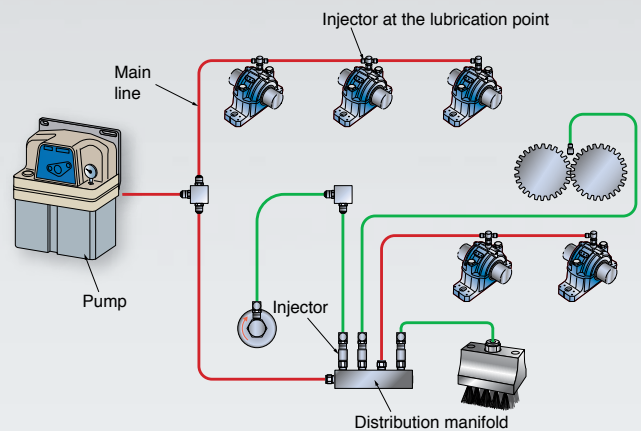

Operation of a direct injector:

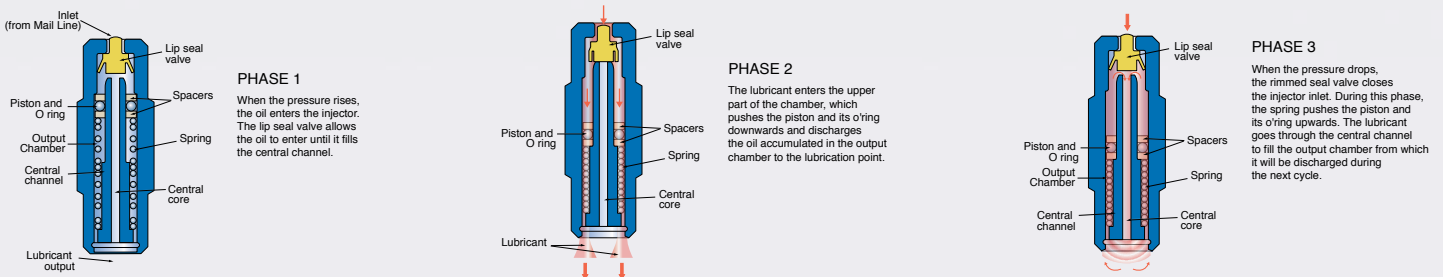

APPLICATIONS :Volumetric systems are dedicated to the cyclic lubrication of small and medium-sized machines and units with multiple locations requiring lubrication (machine tools, wrapping machines, food processing machines, etc.). These systems are easy to design and modify.

3- CENTRALISED LUBRICATION

► Automatic single-line progressive lubrication (for oil or grease with NLGI grade 000 - 2).

Description of the system:

The amount of lubricant sent by the pump is split and sent to each lubrication point via a distributor. These distributors are equipped with several pistons which move successively in turn, and in a cycle, hence the name, progressive system.



A «progressive» distributor includes at least three interdependent pistons. When the distributor receives the pressurised lubricant from the pump at the inlet, the piston is displaced and injects the volume of lubricant stored in the chamber from the other end. When it reaches its travel stop, the next piston is released and displaced. The lubricant received by the piston will be released during return travel, triggered by the travel stop of the previous piston.

► Automatic multi-line progressive lubrication

Description of the system

Each unit can activate several pumps, all acting independently. Each pump supplies a circuit, which may be fitted with a progressive distributor.



APPLICATIONS

Applications where the different locations requiring lubrication need very different lubricant flows (pellet presses, etc.)

Diagram showing the operation of a progressive distributor

■ Inlet
 ■ Static volume (balancing)
 ■ Output

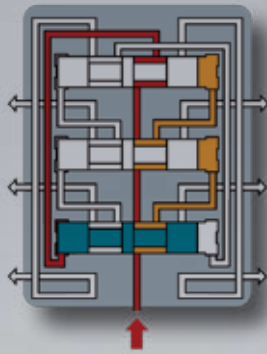

1-The flow of oil will create positive pressure on the left side of the bottom piston. The piston will start to move to the right

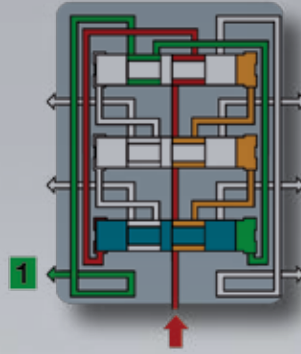

2-During displacement, the piston pushes the volume of oil on its right towards the outlet (1)

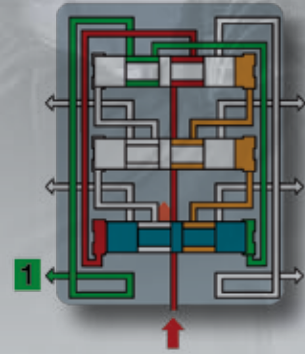

3-IMPORTANT COMMENT: the flow of high pressure oil via the middle column crosses the different levels, regardless of the position of the pistons. The passing of a piston mid-displacement will not interrupt its movement and the piston will continue to its travel stop.

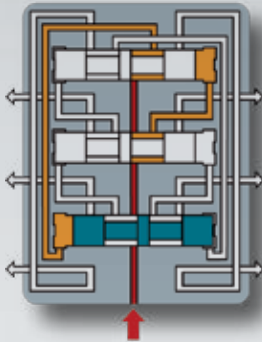

4- The bottom piston has completed its displacement to the right

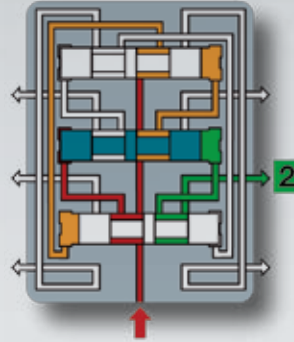

5- Displacement enables positive pressure to be created on the left side of the middle piston. This piston will start moving to the right, and push the oil accumulated on the right to the outlet (2)

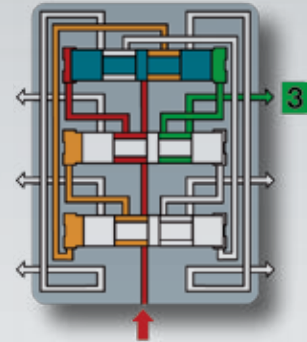

6- When at the right stop, the middle piston will allow positive pressure to form on the left side of the top piston. This piston will start moving to the right, and push the oil on the right to the outlet (3)

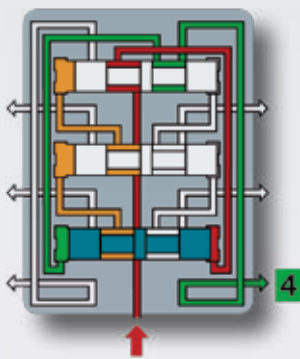

7-When at the right stop, the top piston will allow positive pressure to form on the right side of the bottom piston. This piston will start moving to the left, and push the oil on the left to the outlet (4).

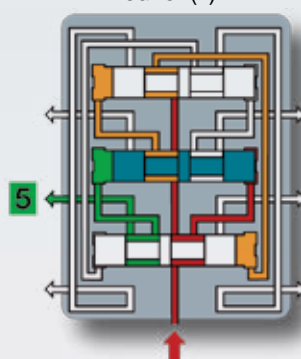

8-When at the left stop, the bottom piston will allow positive pressure to form on the right side of the middle piston. This piston will start moving to the left, and push the oil on the left to the outlet (5).

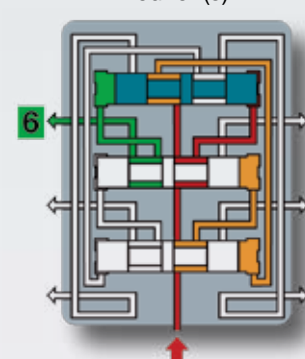

9-When at the left stop, the middle piston will allow positive pressure to form on the right side of the top piston. This piston will start moving to the left, and push the oil on the left to the outlet (6). This displacement brings the system back to stage 1 and the cycle will restart.

APPLICATIONS

Progressive systems are generally used for medium and large-sized equipment, lubricated with oil or grease, which require high pressure to move the lubricant. Sequential operation is blocked if one of the locations lubricated is clogged. This can be detected either visually or automatically.

3-CENTRALISED LUBRICATION

► Automatic dual-line lubrication (for oil or grease with NLGI grade 000 to 3)

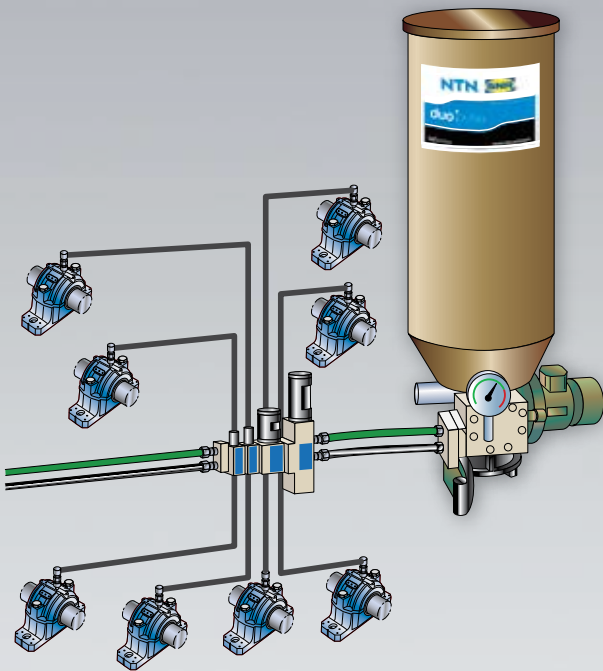

Description of the system

A dual-line lubrication system comprises a pump which feeds many injectors via two separate circuits. The circuits are pressurised alternatively by a reverser. When the pressure in the 1st circuit reaches an upper threshold, the reverser reverses the pressure in the 2 circuits and so on. System operation is controlled and monitored by a control unit.

A visual indicator is available on each dual-line injector as standard. Unlike the progressive system, a blocked outlet or defective injector will not lead to an interruption in lubrication to other locations.

APPLICATIONS : The advantage of a dual-line unit is the ability to precisely dose the amount of lubricant over large distances (cement plants, steel works, mines, electrical plants, large machines).

► Automatic air/oil lubrication



Description of the system:

The oil is precisely dosed by a pneumatic pulse generator. The oil is injected into a mixing chamber with compressed air. The length of hose between this chamber and the outlet is enough to generate a continuous flow of oil. Small drops of oil are dispersed at the hose outlet, directly onto the lubrication point, with no mechanical contact.

Cycle times and dosing may be adjusted to a range of conditions.

APPLICATIONS : This system is the most appropriate for the lubrication of bearings operating at high speeds, such as spindles in machine tools. It can also be used to lubricate presses.

ACTIVITY	APPLICATION	SINGLE-POINT	VOLUME*	PROGRESSIVE (OIL OR GREASE)	DUAL LINE	AIR/OIL	CIRCULATION (OIL)
AGRICULTURE	Tractor						
	Agricultural machinery						
FOOD	Food manufacturing						
	Bottling						
	Confectionery						
MINES & PUBLIC WORKS	Mines						
	Cement works						
	Construction equipment						
MACHINES AND EQUIPMENT	Packing machine						
	Mining machinery						
	Machine tools						
HANDLING	Lifts						
	Cranes						
	Escalators						
	Cable cars						
	Conveyors						
	Chains						
PAPER	Paper mills						
	Printing						
PUMPS AND MOTORS	Electric motors						
	Fans						
	Pumps						
METALLURGY	Rolling machines						
	Presses						
	Furnaces						
DRIVE SYSTEMS	Gearboxes						
PRODUCTION OF ENERGY	Wind turbines						
NAVAL	Locks						
	Dams						
	Ships						
RAIL SECTOR	Locomotives						
	Rolling stock						

* Oil or grease, max. grade 00

A - PRODUCTS

LUB'SOLUTIONS PRODUCTS FOR VOLUMETRIC LUBRICATION



IN'PULSE PUMPS

BENEFITS

Reliable and advanced:

Gear pump for flows up to 180 cm³ / minute at 30 bars equipped with a high-performance electric motor with minimum electrical consumption.

Service temperature: from -5°C to +60°C.

Fully equipped:

Low level sensor, pressure indicator and switch, 3-litre transparent plastic tank.

Multi-parameter programmer with LCD (option).



DISTRIBUTION MANIFOLDS

BENEFITS

Practical and light:

Aluminium manifold designed for rapid assembly. Fitted with a quick push-in connector to each outlet. An additional plug is supplied as standard to close the circuit. Available versions: 1 to 6 outlets.

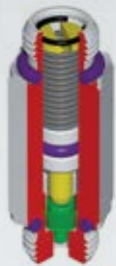

INJECTORS

BENEFITS

Practical

Injectors delivered with a quick push-in connector. Simply screw the injectors into the manifold and couple to the hoses.

Injected volumes available: 0.03, 0.06, 0.1, 0.2, 0.3 and 0.5 cm³



HOSES

BENEFITS

Reliable and advanced:

Hoses with a capacity of 30 bars in hydrocarbon-resistant material.

Practical:

2 hose sizes available (downstream and upstream from the injectors), suitable for the quick push-in connectors on the distributors, manifolds and injectors.

For other options (type of connectors, installation services, etc). please contact us.

NOTE: the technical characteristics of pumps and their accessories may change.

Please refer to our web site www.ntn-snr.com, to check the latest updates, or contact us.

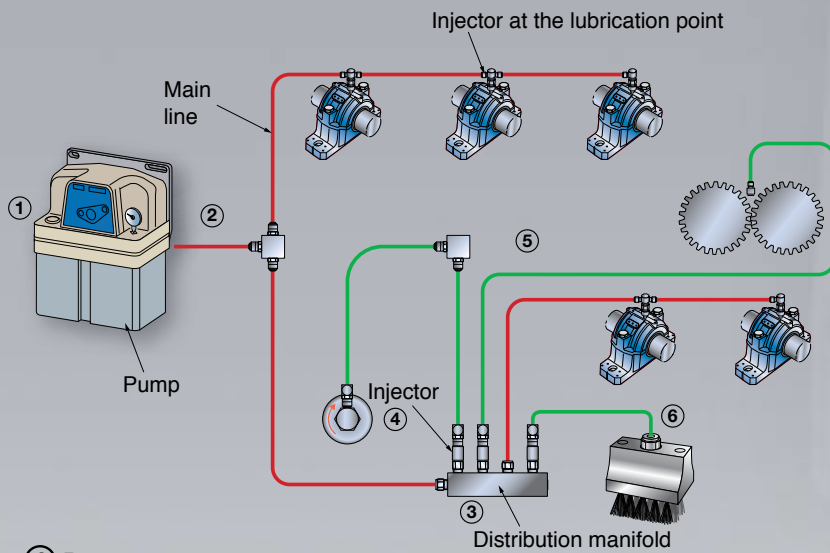

Diagram and parts list for the IN'PULSE system

1 Pump

VOLTAGE / FREQUENCY*	TYPE OF CONTROL	TANK LEVEL CONTROL	PRODUCT REFERENCE	T.D.
110 V / 50 Hz	Manuel	Yes	LUBSO INPULSE 110V MAN 50 HZ	51
	Programmable		LUBSO INPULSE 110V PROG 50 HZ	
230 V / 50 Hz *	Manuel		LUBSO INPULSE 230V MAN 50 HZ	
	Programmable		LUBSO INPULSE 230V PROG 50 HZ	

* 60 Hz made to order to take order in 60Hz version, please modify the reference. Eg. LUBSO INPULSE xxxV PROG 60HZ

2 Primary flexible hose (for use between the pump pre-equipped with a 1/4 x 6 mm outlet connector and the injectors)

DIAMETER	PRODUCT REFERENCE (25 M CROWN)	T.D.
4,5 x 6 mm	LUBSO HOSE 6MM 25M	57

3 Manifolds (supplied with 2 push-in connectors, 4,5 x 6 mm, and 1 plug)

NUMBER OF OUTLETS	PRODUCT REFERENCE	D.T.
1	LUBSO MANIFOLD 1 OUT	52
2	LUBSO MANIFOLD 2 OUT	
3	LUBSO MANIFOLD 3 OUT	
4	LUBSO MANIFOLD 4 OUT	
5	LUBSO MANIFOLD 5 OUT	
6	LUBSO MANIFOLD 6 OUT	

4 Positive discharge injectors (supplied with 1 push-in connector, 4 x 3 mm)

FLOW (cm ³)	PRODUCT REFERENCE	T.D.
0.03	LUBSO INJECT 003	52
0.06	LUBSO INJECT 006	
0.1	LUBSO INJECT 010	
0.2	LUBSO INJECT 020	
0.3	LUBSO INJECT 030	
0.5	LUBSO INJECT 050	
0,75	LUBSO INJECT 075	
1	LUBSO INJECT 100	

5 Secondary flexible hose (for use between the injector and the lubrication point)

DIAMETER	PRODUCT REFERENCE (25 M CROWN)	T.D.
4 x 3 mm	LUBSO HOSE 4MM 25M	57

6 Connectors at the lubrication point and hose fitting accessories

DESCRIPTION	QUANTITY/ BAG	PRODUCT REFERENCE	T.D.
Push-in connector, 1/8, for hose with outer diameter 4	10	LUBSO PUSHIN CONNECTOR 1/8 x 4MM	58
Attachment hook, 1 hose, dia. 4 mm (1 screw)	50	LUBSO HOOK 1 DIA 4	
Attachment hook, 2 hoses, dia. 4 mm (1 screw)	50	LUBSO HOOK 2 DIA 4	
Attachment hook, 3 hoses, dia. 4 mm (1 screw)	50	LUBSO HOOK 3 DIA 4	
Attachment hook, 4 hoses, dia. 4 mm (2 screws)	50	LUBSO HOOK 4 DIA 4	
Attachment hook, 1 hose, dia. 6 mm (1 screw)	50	LUBSO HOOK 1 DIA 6	
Attachment hook, 2 hoses, dia. 6 mm (2 screws)	50	LUBSO HOOK 2 DIA 6	
Attachment hook, 3 hoses, dia. 6 mm (2 screws)	50	LUBSO HOOK 3 DIA 6	
Self-tapping screw, M4 x 10 mm	100	LUBSO SCREW M4X10	

B - LUB'SOLUTIONS PRODUCTS FOR PROGRESSIVE LUBRICATION



MULTI-PULSE PUMPS

BENEFITS

Reliable and advanced:

Provides a pressure of 280 bars

A direct current (D.C.) model with a capacity of 4 litres, designed for mobile equipment and use in tough environments, such as construction machines.

An alternating current (A.C.) model with a capacity of 5 litres, designed for large industrial units.

Fully equipped:

Version with or without a multi-parameter programmer. Electronic surveillance of lubricant level, pump operation, progressive distributor and the integrity of supply hoses. Diagnostic and event logging. Transparent plastic tank.

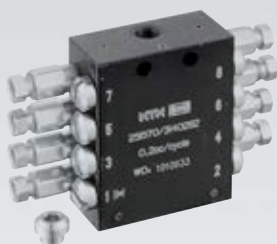

DISTRIBUTORS

BENEFITS

Practical and robust :

Zinc-plated steel casing for pressure of up to 300 bars. Supplied as standard with connectors on each outlet and with plugs to block unused outlets.

Available versions: 6, 8, 10 and 12 outlets. Visual and electric sensors available as an option.

Service temperature: from -10 to + 70°C.



VISUAL OR ELECTRONIC INDICATOR FOR LUBSO DISTRIBUTOR

BENEFITS

LUBSO VISUAL INDICATOR and LUBSO ELECT INDICATOR

monitor the correct operation of the progressive system without reducing the number of outlets available on the distributor.



HOSES

BENEFITS

Practical and reliable:

Reinforced high pressure hose in hydrocarbon-resistant material. Hoses must be cut to length and crimped on the two connectors.

For other options (types of connectors, installation services, etc.) please contact us

NOTE :the technical characteristics of pumps and their accessories may change.

Please refer to our web site www.ntn-snr.com, to check the latest updates, or contact us.

① Pumps

POWER SUPPLY	TYPE OF CONTROL	TANK LEVEL MONITORING	PRODUCT REFERENCE	T.D.
12 VDC	Manuel	Yes	LUBSO MULTIPULSE DC 12V MAN	53
	Programmable		LUBSO MULTIPULSE DC 12V PROG	
24 VDC	Manuel		LUBSO MULTIPULSE DC 24V MAN	
	Programmable		LUBSO MULTIPULSE DC 24V PROG	
110 / 230 VAC 50Hz *	Manuel		LUBSO MULTIPULSE AC 110/230V MAN 50HZ	54
	Programmable		LUBSO MULTIPULSE AC 110/230V PROG 50HZ	

* Also available in 60 Hz. To take order in 60Hz version, please modify the reference.
Eg. LUBSO MULTIPULSE AC110/230V MAN 60HZ

② Standard HP hose (for use between the pump, distributors, lubrication points and connectors)

DESCRIPTION	QUANTITY / BAG	PRODUCT REFERENCE (25 M CROWN)	T.D.
HP hose, dia 8.3 x 6mm	25 m	LUBSO HOSE HP 8MM 25M	57
Collar & straight insert, length 38 mm, dia. 6 mm	10	LUBSO COLLAR & INSERT ST L38XD6	
Collar & 90° insert, length 38 mm, dia. 6 mm		LUBSO COLLAR & INSERT 90D L38XD6	

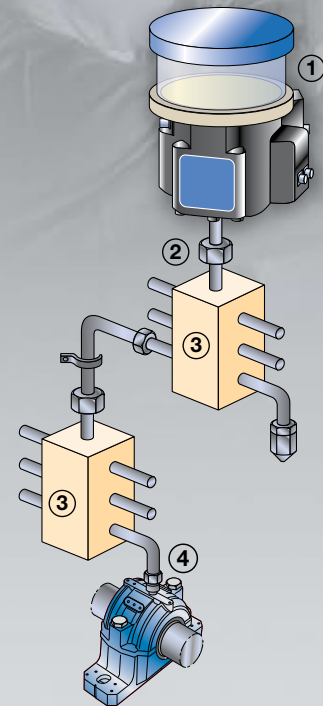

Diagram and parts list for the MULTI'PULSE system

③ Distributor (identical flow at each outlet) and piston position indicator

DESCRIPTION	PRODUCT REFERENCE	T.D.
Distributor: 1 to 6 outlets*	LUBSO DISTRIBUTOR 6 OUT	55
Distributor: 7 to 8 outlets*	LUBSO DISTRIBUTOR 8 OUT	
Distributor: 9 to 10 outlets*	LUBSO DISTRIBUTOR 10 OUT	
Distributor: 11 to 12 outlets*	LUBSO DISTRIBUTOR 12 OUT	
Visual indicator	LUBSO VISUAL INDICATOR	
Electric indicator	LUBSO ELECT INDICATOR	

④ Connectors at the lubrication point and hose fitting accessories

DESCRIPTION	QUANTITY / BAG	PRODUCT REFERENCE	T.D.
1/8"connector (for smooth end-pieces, dia. 6)	10	LUBSO CONNECTOR 1/8 x 6MM	58
Self-tapping screw, M4 x 10 mm	100	LUBSO SCREW M4X10	
Attachment hook, 1 hose, dia. 8 mm (1 screw)	50	LUBSO HOOK 1 DIA 8	
Attachment hook, 2 hoses, dia. 8 mm (2 screws)	50	LUBSO HOOK 2 DIA 8	
Attachment hook, 3 hoses, dia. 8 mm (2 screws)	50	LUBSO HOOK 3 DIA 8	
Caps for distributor	10	LUBSO PLUG DISTRIBUTOR	

Manual and programmable versions of LUBSO MULTI'PULSE models are available as standard with one pump. One or two additional pumps can be added in order to double or triple the amount of lubricant supplied or to create up to 3 independent lubrication circuits. Contact us for details.

DESCRIPTION	PRODUCT REFERENCE	T.D.
Multipulse fixed flow pump, 12/24 VDC	LUBSO PUMPING ELEMENT DC	53
Multipulse variable flow pump, 12/24 VDC	LUBSO PUMPING ELEMENT DC ADJUSTABLE	
Multipulse fixed flow pump, 110/230 VAC	LUBSO PUMPING ELEMENT AC	54

3-CENTRALISED LUBRICATION

KIT TO ASSEMBLE THE DISTRIBUTOR DIRECTLY ONTO THE MULTI'PULSE AC 110/230 V PUMP

This kit contains a rigid bent hose and 2 attachment screws, and can be used to assemble any LUBSO DISTRIBUTOR (6 to 12 outlets) directly under the base of the MULTI'PULSE AC 110 / 230 pump. This will save space for compact units.

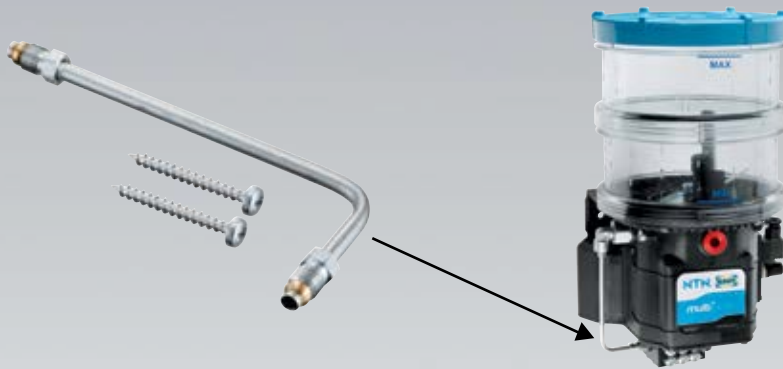

DESCRIPTION	PRODUCT REFERENCE	T.D.
Kit to assemble the distributor onto the MULTI'PULSE AC 110/230V pump	LUBSO MULTIPULSE AC FIXING KIT	55

C - MULTI-LINE LUB'SOLUTIONS PRODUCTS

MULTI'PULSE AC AND DC PUMPS

MULTI'PULSE pumps can be used for units with several parallel lines, each connected to a pump.

This enables several large machines or industrial processes, with several lubrication points with widely varying flows, to be supplied.

D - LUB'SOLUTIONS PRODUCTS FOR DUAL-LINE LUBRICATION

DUO'PULSE PUMPS

BENEFITS

Power and high capacity:

This advanced pump can distribute up to 50 cm³ of grease or oil per minute with a pressure of 400 bars. Coupled with a reverser, this model is suitable for very large industrial units with multiple locations to be lubricated.



For your dual-line units (design, manufacturing, implementation), please contact us for details. The LUB'SOLUTIONS range includes various types of dual-pumps (tank size, type of reverser, etc.)

E - LUB'SOLUTIONS AIR – OIL LUBRICATION PRODUCTS



AIR'PULSE PUMPS

BENEFITS

Reliable & simple:

Modular and compact design. One single adjustment required per output. Programmable or remote cycle control. Integrated surveillance with a simplified interface.

Low-cost and clean:

This type of injection reduces lubricant consumption, and avoids the recycling of lost lubricant and environmental problems caused by the use of oil mist.

Note : the technical characteristics of pumps and their accessories may change. Please refer to our web site www.ntn-snr.com, to check the latest updates, or contact us.

NUMBER OF OUTLETS	POWER SUPPLY	PRODUCT DESIGNATION	T.D.
1	24 VDC	LUBSO AIRPULSE 24V 1 JET	56
2		LUBSO AIRPULSE 24V 2 JET	
3		LUBSO AIRPULSE 24V 3 JET	
4		LUBSO AIRPULSE 24V 4 JET	
5		LUBSO AIRPULSE 24V 5 JET	
6		LUBSO AIRPULSE 24V 6 JET	
7		LUBSO AIRPULSE 24V 7 JET	
8		LUBSO AIRPULSE 24V 8 JET	
1	110 VAC 50/60 HZ	LUBSO AIRPULSE 110V 1 JET	
2		LUBSO AIRPULSE 110V 2 JET	
3		LUBSO AIRPULSE 110V 3 JET	
4		LUBSO AIRPULSE 110V 4 JET	
5		LUBSO AIRPULSE 110V 5 JET	
6		LUBSO AIRPULSE 110V 6 JET	
7		LUBSO AIRPULSE 110V 7 JET	
8		LUBSO AIRPULSE 110V 8 JET	

NOTE :

Electric connection: AIR'PULSE pumps are supplied with a 7-pin male cylindrical connector. On request, the corresponding female connector with 2 metres of cable is also available:

LUBSO AIRPULSE PLUG & CABLE 2M

Cable to connect the AIR'PULSE pump

- power supply
- alarms (high and low levels, etc.)

PRODUCT DESIGNATION

LUBSO AIR'PULSE PLUG & CABLE 2M

All AIR'PULSE systems are supplied assembled and ready for fitting. Each outlet includes one micro-pump and 2 metres of cable.

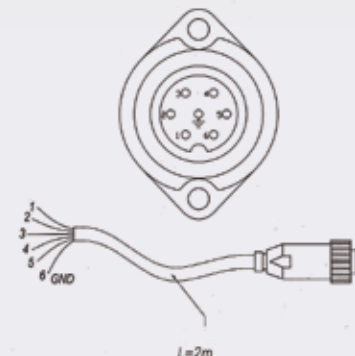

3-CENTRALISED LUBRICATION

F - CIRCULATING LUBRICATION SYSTEMS

For your circulating lubrication systems (design, manufacturing, implementation), please contact us for details.



G - FLOW CONTROL PRODUCTS AND ACCESSORIES



OIL FLOW CONTROLLER

BENEFITS

Reliable & simple:

Modular and compact design. Visual monitoring window. 4 -20 mA interfacing.

Universal fitting:

Can be used for all viscosities below 1000 cSt.

Operating temperature: from - 20° to 60° C (from - 4° to 140 F°)

Manual or power-operated flow adjustment

In addition to flow meters, **LUB'SOLUTIONS** can also provide all the accessories you need to install centralised lubrication systems: pressure switches, thermometers, filters, heat exchangers, etc. These items vary widely and we cannot include the full range in this catalogue. Please contact us if you would like to receive more details.

NOTE : the technical characteristics of pumps and their accessories may change.

Please refer to our web site www.ntn-snr.com, to check the latest updates, or contact us.

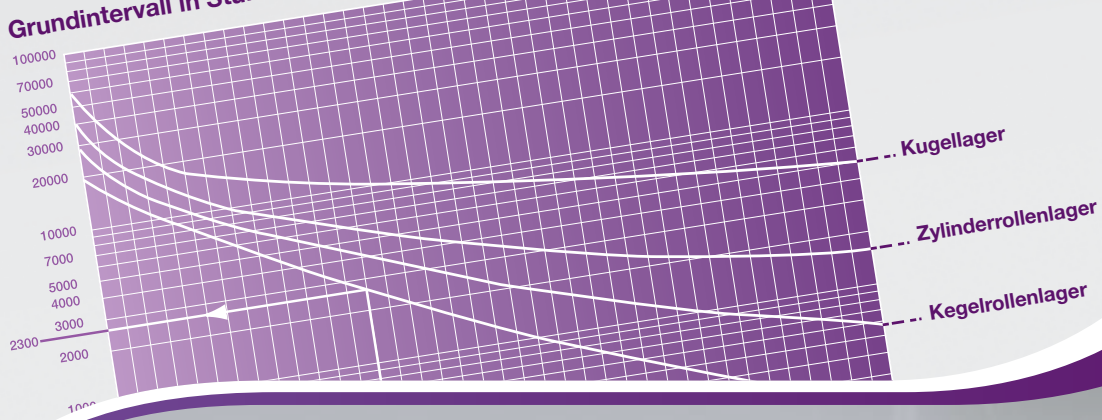

Lubrication theory and methods

P. 41

Product interchanges for replacement.....	P. 42
LUB'SOLUTIONS services.....	P. 43
Lubrication requirement design tools.....	P. 44

4- LUBRICATION THEORY AND METHODS

4•1 - PRODUCT INTERCHANGES FOR REPLACEMENT

NOTE : This information is provided as an indication. The wide range of technical data provided for the different models is not compatible with a list of precise equivalences, however close equivalent products are shown.

PUMPS				
Model	Manufacturer	Similar LUB SOLUTIONS model	Technical data	Remarks
SUREFIRE GMK MKU2 SMART EA TRONIC	BIJUR TECHNOSYSTEMS VOGEL (SKF) DROPSA BEKA	IN'PULSE 110/230 VAC	Page 34	Check the number of outlets and flow
MULTIPOINT QSL MODEL P203 MODEL P233 EP1 PICO BRAVO KFB FKGM BM B KFA	BIJUR LINCOLN LINCOLN LINCOLN BEKA BEKA DROPSA VOGEL SKF BEKA BIJUR VOGEL SKF	MULTI'PULSE AC & DC	Page 36	
FZA BP S MULTILUBE MULTIFLEX ZPU	BIJUR BIJUR VOGEL SKF VOGEL SKF LINCOLN	DUO'PULSE	Page 38	
VECTOLUB VIP 4 AIR GLS	VOGEL (SKF) DROPSA TECHNOSYSTEMS	AIR'PULSE	Page 39	
DISTRIBUTORS AND INJECTORS				
MONOFLEX 342 ;343 ; 345 351 to 355 391 to 393	VOGEL SKF	LUBSO INJECT	Page 34	Check the number of outlets and flow
33V	DROPSA			
ZEM	BIJUR			
SKD or SKN	TECHNOSYSTEMS			
VPBM/VPBG	VOGEL SKF	LUBSO DISTRIBUTOR	Page 36	
VPKM/VPMG	LINCOLN			
DPX	TECHNOSYSTEMS			
MXF	BEKA			
SMP	DROPSA			
PV-B	BIJUR			
DM	BIJUR	LUBSO DUOPULSE FEEDER BLOCK	Page 38	
VSG, VSL, VSKH, VSKV, DU1, MP2, EM-U2	LINCOLN			
DUOFLEX 546	VOGEL SKF	LUBSO DISTRIBUTOR DUO		
BK ;BH ;BM	TECHNOSYSTEMS			

4•2 - LUB'SOLUTIONS SERVICES

Do you need assistance with defining your industrial lubrication requirements for your application?
Do you need to design and produce the most suitable lubrication system for your machine?
Do you need an installer to implement or modify a system?
Are you facing operating difficulties with your industrial lubrication system?

LUB'SOLUTIONS by NTN-SNR Experts & Tools is a team primarily of engineers and technicians available to provide support for all your projects or tasks.

Contact us directly at NTN-SNR Experts & Tools for these requirements (tel. +334 5065 3000, web site www.expertsandtools.com) or contact us via your dealer or your NTN-SNR sales representative.

4•2.1 - ADVICE TO DEFINE YOUR REQUIREMENTS

Our engineers can assist you in selecting the most appropriate lubrication technology, for your application and its environment, and to design the best performing system for your machine.

In addition, working with NTN-SNR when designing a machine has a significant advantage: Designing the bearings and their lubrication system simultaneously will ensure superior dependability and optimal operation for your industrial unit at an optimised cost.

Modifying existing units

We can assist you with equipping older machines designed without a centralised lubrication system, or existing but obsolete systems. LUB SOLUTIONS can determine the nearest or most appropriate equivalent system for your equipment.

4.2.2 - DESIGN AND MANUFACTURING OF MADE-TO-MEASURE SYSTEMS

NTN-SNR designers can provide customised technical and commercial services plus technical documents (block diagrams, lists of parts) based on your specifications.

Once you have approved our proposal, NTN-SNR will then produce your made-to-measure lubrication system.

4.2.3 - INSTALLING LUBRICATION SYSTEMS ON CUSTOMER SITES

NTN-SNR technicians are at your disposal to install your industrial lubrication systems, designed by us, on your machines and on your site.

4.2.4 - AFTER-SALES SERVICE

Even outside of the warranty period, NTN-SNR can provide maintenance and servicing services for industrial lubrication systems. We also offer this service for systems designed by third parties.

4- LUBRICATION THEORY AND METHODS

4•3 - LUBRICATION REQUIREMENT DESIGN TOOLS

SELECTING THE VISCOSITY OF LUBRICANTS (OIL OR GREASE)

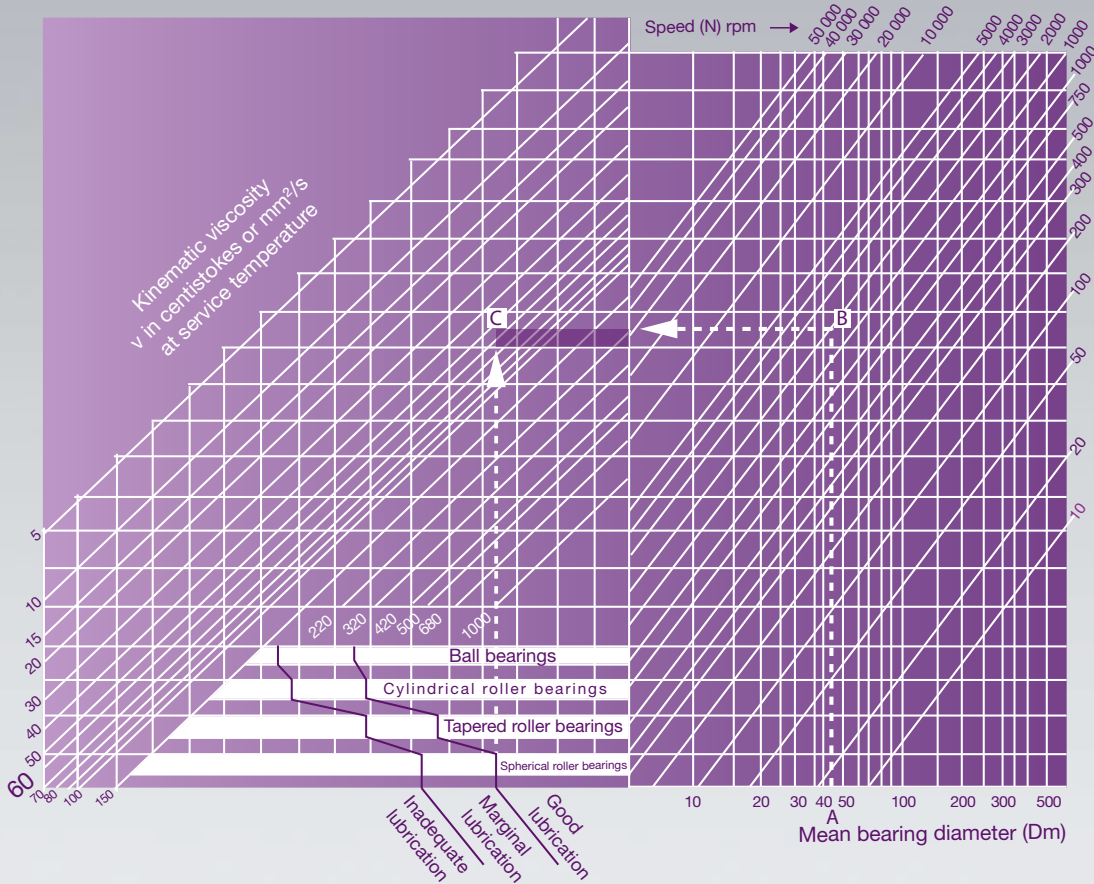

- Determine the mean diameter of the bearing (A)= (Bore + outer diameter)/2
- Find the intersection with the line for the speed of rotation of the bearings by marking point B on the graph
- Identify point C, intersection of the horizontal line from B and the vertical line running from the effective lubrication limit per type of bearing.
- Determine the value of the oblique line passing through C (60, in this case)

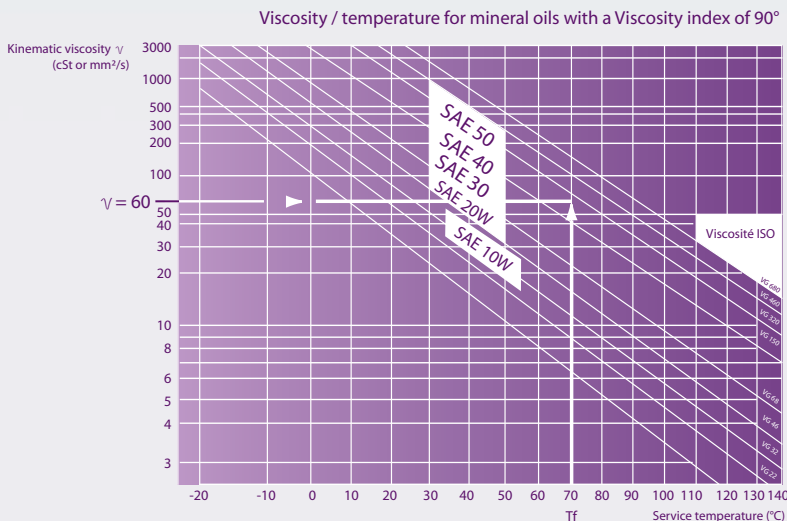

- Then calculate the viscosity of the lubricant to be selected on the basis of the service temperature of the bearing.

Mark the value of calculated basic viscosity on the vertical axis. Identify the intersection between this value and the service temperature of the bearing

The target viscosity is the value of the oblique line passing through this intersection. (Approximately SAE 50, i.e. VG 300 in this case)

INITIAL CHARGE OF LUBRICANT AND RELUBRICATION

• OIL LUBRICATION (MINIMUM QUANTITY)

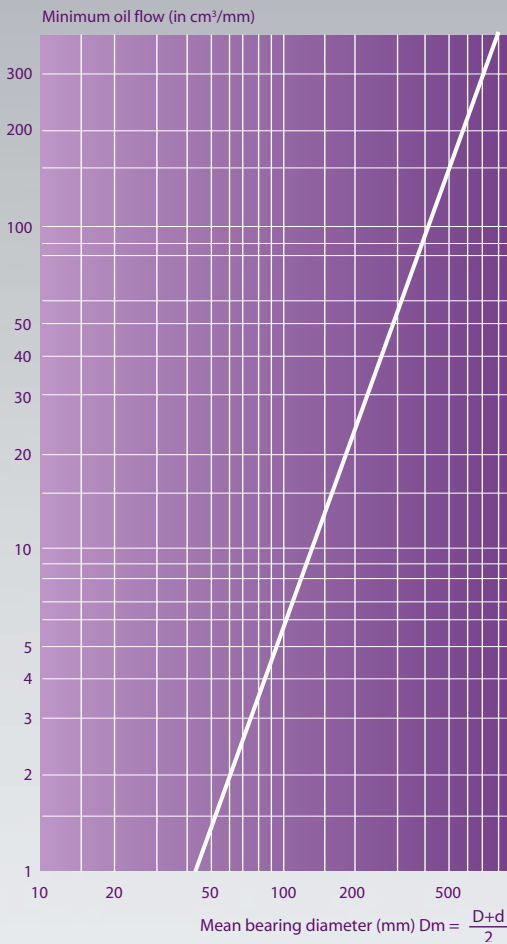

• GREASE LUBRICATION (DOSING)

Excess grease can lead to heating. Grease must occupy 20 to 30% of free volume within the bearing.

Formula to calculate the weight of grease required:
 $G = 0.005 D \cdot B$

G =Gram (or cm³)

D =Outer diameter of the bearing in mm

B = Width of the bearing in mm

Exceptions:

- The quantity of grease may be increased by 20% for bearings equipped with a grease evacuation hole
- A bearing rotating at a very low speed can be filled completely

• FREQUENCY OF RELUBRICATION

Basic frequency in hours

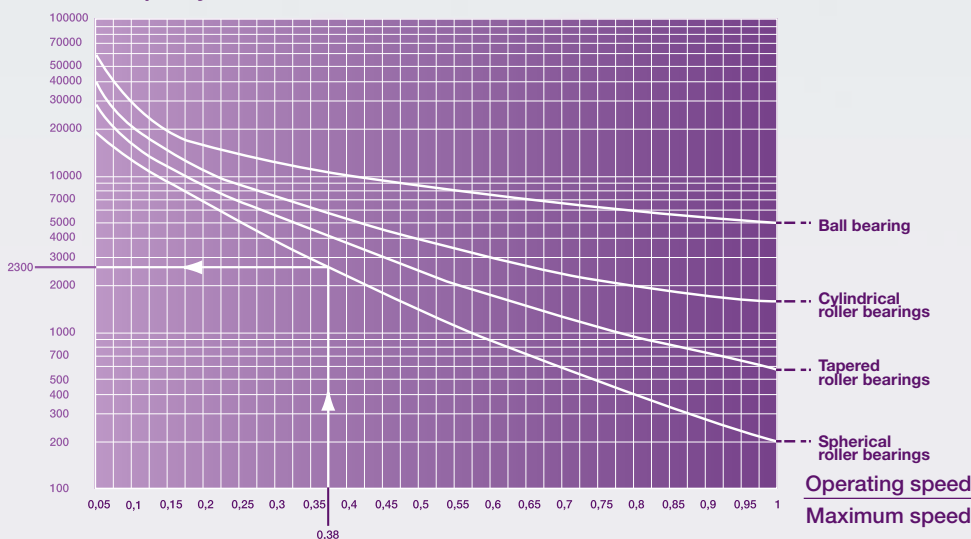

The basic frequency (F_b) of relubrication depends on the type of bearing and the ratio of operating speed to the maximum speed indicated in the bearing characteristics.

4- LUBRICATION THEORY AND METHODS

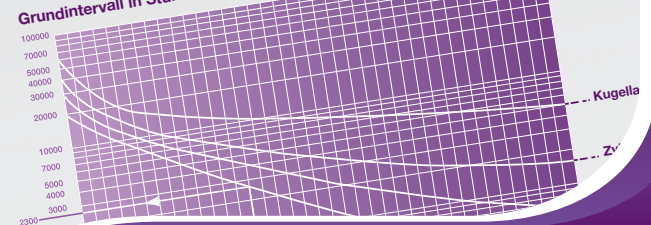

This basic frequency must be corrected by the following coefficients on the basis of the specific conditions of the environment of the mechanism (dust, humidity, impact, vibrations, vertical axis, service temperature, etc.) according to the formula: $F_c = F_b \cdot T_e \cdot T_a \cdot T_t$

Conditions	Environment	Applications	Temperature		
	Dust Humidity Condensation	With shocks Vibrations Vertical axis	Level	For standard grease	For high temperature grease
Coefficients	T_e	T_a		T_t	T_t
Mean	0,7 to 0,9	0,7 to 0,9	75°C	0,7 to 0,9	-
High	0,4 to 0,7	0,4 to 0,7	75°C to 85 °C	0,4 to 0,7	0,7 to 0,9
Very high	0,1 to 0,4	0,1 to 0,4	85°C to 125 °C	0,1 to 0,4	0,4 to 0,7
	-	-	130°C to 170 °C	-	0,1 to 0,4

Example: a 22 212EA bearing, lubricated with standard grease, rotating at 1500 rpm in a dusty environment, at 90°C, without any other operating restrictions:

22212 = Spherical roller bearing

Max. speed = 3900 rpm

Operating speed = 1500 rpm

$$\frac{V_{\text{operating}} = 1500 \text{ tr/mn}}{V_{\text{speed}} = 3900 \text{ tr/mn}} = \frac{1500}{3900} = 0,38 \rightarrow \text{Basic frequency } F_b = 2300 \text{ H}$$

$T_e = 0,5 \rightarrow$ dust
 $T_a = 0,9 \rightarrow$ normal
 $T_t = 0,3 \rightarrow$ 90°C

• WEIGHT OF THE GREASE TO BE REPLACED

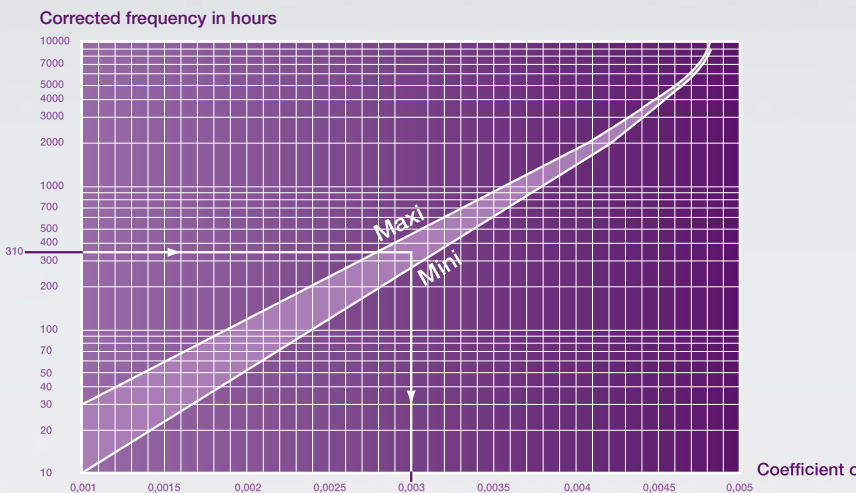

This corrected frequency can be used to determine the weight of grease to be added, depending on:

- bearing width B,
- outer diameter D,
- coefficient c taken from the graph below based on the formula

$$P = D \times B \times c$$

Example :

for bearing 22 121 (roller bearings)

P= weight of the grease

Add approximately 9 grams every 310 hours of operation

An initial approximation gives the following values:

FLOW ADJUSTMENT PARAMETERS

Shaft diameter	Frequency of manual lubrication (1 pump stroke = 0,5 cm³)	Quantity per day	Frequency of replacement of the automatic lubricator
100 à 120 mm	8 pump strokes per day	3 to 4 cm³	1 month
80 à 100 mm	4 pump strokes per day	2 cm³	2 months
65 à 80 mm	16 to 20 pump strokes per week	1,5 cm³	3 months
50 à 65 mm	16 to 20 pump strokes every 15 days	0,7 cm³	6 months
< 50 mm	16 to 20 pump strokes per month	0,3 cm³	12 months

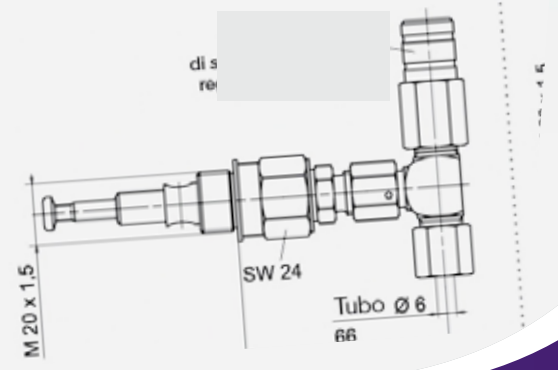
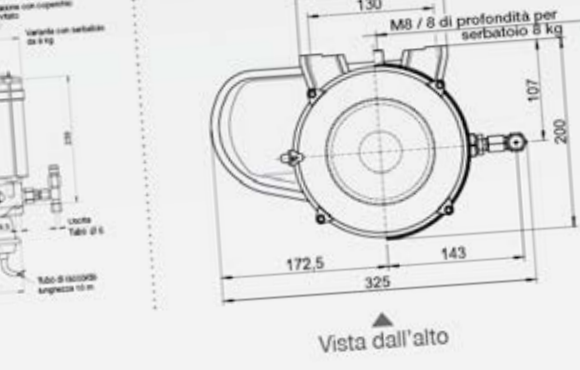

Technical datas for products

P. 48

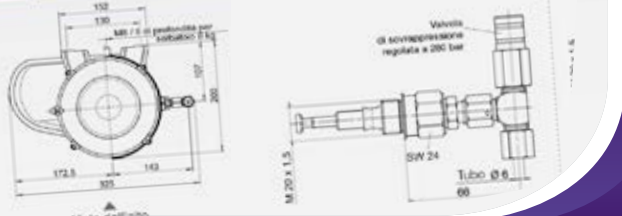

5- TECHNICAL DATAS FOR PRODUCTS

Reference : LUB GREASE GUN SET

> P 16

TECHNICAL DATA

Grease gun designed for use with 400 g cartridges or filled directly with grease, with a drain and filler valve. This gun is compatible with standard grease cartridges, particularly NTN-SNR LUB grease cartridges.

- material: strong sheet of steel
- weight: 1 130 g with rigid hose and nozzle
- rigid steel, 150 mm
- hydraulic type steel nozzle, 3 jaws, with flat bar (10x100 thread)

Capacity	Flow	Service pressure	Maximum pressure
500 cm ³	0,50 cm ³	180 bars	350 bars

- Lubrication accessories supplied with the gun: a bichromate zinc-plated steel extension (M10 x 100 thread).
- Option: two plastic nozzles with a standard thread

SINGLE-POINT BOOSTER AUTOMATIC LUBRICATOR

LUBER READY (NAME OF THE LUBRICANT)

> P 18

Capacity	125cm ³
Duration of distribution	Adjustable form 1 to 12 months
Ambiant temperature range	From -20°C to +60°C
Maximum service pressure	4 bars
Drive	Electrochemical reaction
Maximum distance allowable between the automatic lubricator and the lubricant point	Oil 1500mm and inner diameter 6mm Grease 1000mm and inner 6mm
Intrinsic safety certification	I M1 Ex ia I II 1G Ex ia IIC T6 II 1D Ex iaD 20 T 85°C
Recommended storage temperature	20°C
Maximum storage time and expiry dates	Max.1 year in storage (grease) + 1 year in service
Weight (with lubricant)	Approx. 260g

* The maximum length of the lubricant line depends on ambient temperature, the type of grease and back pressure generated by the application

Duration of the discharge of the READY Booster at 20°C

Data based on laboratory back pressure tests and using grade 2 greases. Possible residue for a temperature >40°C or an emptying period of > 6 months

 1 month 3 months 6 months 9 months 12 months	1 month	3 months	6 months	9 months	12 months
- 20°C	2	5	10	13	15
0°C	1,3	3,8	7,2	11	13
+20°C	1	3	6	9	12
+40°C	0,8	2,5	5,2	7,5	10
+60°C	0,6	2	4	-	-

Adjustment of flow at 20°C (grease)

Output selector (months)	1	2	3	4	5	6	7	8	9...	...12
Lubricant / day (cm ³)	4,2	2,1	1,4	1,0	0,8	0,7	0,6	0,5	0,5	0,4
Lubricant / week (cm ³)	29,2	14,6	9,7	7,3	5,8	4,9	4,2	3,6	3,2	2,6
Pump strokes / day	8 - 9	4	3	2	1 - 2	1 - 2	1	1	1	1
Pump strokes / week	60	29 - 30	19 - 20	14 - 15	11 - 12	9 - 10	8 - 9	7 - 8	6 - 7	5 - 6

1 pump stroke of the grease gun distributes: 0.5 cm³/ piston displacement

LUBER SMART (NAME OF THE GREASE)

► P 20

Complete kit (control unit + lubricant tank with gas cells and batteries + plastic cover)

LUBER SMART REFILL (NAME OF THE GREASE)

► P 21

Lubricant tank with gas cells and batteries + plastic cover

Capacity	130 cm ³
Duration of distribution	Adjustable from 1 to 12 months (in whole months)
Ambient temperature interval	from -20°C to +60°C
Maximum service pressure	6 bars
Drive	Gas generation cell with electronic temperature compensation
Maximum distance allowable between the automatic lubricator and the lubrication point	Oil 1500 mm and inner diameter 4 mm Grease 300 mm and inner diameter 6 mm*
Intrinsic safety certification	I M1 Ex ia I Ma II 2G Ex ia IIC T4 Gb II 2D Ex ia IIIC T135°C Db
Protection index	IP 65
Recommended storage temperature	20°C
Maximum storage time and expiry dates	Max. 2 years in storage (grease) + 1 year in service **
Weight (with lubricant)	Approx. 280 g including the electronic unit: 40 g)

* 1000 mm with a min. inner diameter of 10 mm. The maximum length of the lubricant line depends on ambient temperature, the type of grease and back pressure generated by the application.

** the electronic control unit is reusable and not concerned by this limit.



Adjustment of flow

Flow/Adjustment (month)

Setting (in months)	1	2	3	4	5	6	7	8	9...	...12
Lubricant / day (cm ³)	4,3	2,2	1,4	1,1	0,9	0,7	0,6	0,5	0,5	0,4
Lubricant / week (cm ³)	30,5	15,2	10,1	7,6	6,1	5,1	4,3	3,8	3,4	2,7
Pump strokes / day	8 to 9	4 to 5	2 to 3	2 to 3	2	1 to 2	1	1	1	< 1
Pump strokes / week	60 to 62	30 to 32	20 to 21	15 to 16	12 to 13	10 to 11	8 to 9	7 to 8	6 to 7	5 to 6

1 pump stroke (grease gun) distributes: 0.5 cm³/ piston displacement

5- TECHNICAL DATAS FOR PRODUCTS

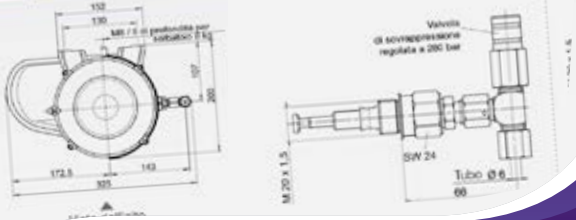

LUBER DRIVE KIT (CAPACITY, NAME OF THE LUBRICANT)

> P 22

Complete kit (Motor + 120 or 250 cm³ lubricant tank + battery pack + reinforced base + 4 adapters)

LUBER DRIVE REFILL (CAPACITY, NAME OF THE LUBRICANT)

> P 23

120 or 250 cm³ lubricant tank + battery pack

Capacity	120 cm ³ or 250 cm ³
Duration of distribution	1, 3, 6 or 12 months
Ambient temperature range	from -10°C to +50°C
Maximum service pressure	5 bars
Drive	Electromechanical
Maximum distance allowable between the automatic lubricator and the lubrication point	Oil 5 metres and inner diameter 4 mm Grease 3 metres and inner diameter 6 mm
Status indicators	In good working order, operational, empty, defective
Recommended storage temperature	20°C
Maximum storage time	3 years *
Battery pack	3 x 1,5 V AA
Adapters included in the kit	Adapter G1/4 – G1/8 Adapter G1/4 – M6 Adapter G1/4 – M8 X 1 Adapter G1/4 – M10 X 1
Weight (with lubricant)	DRIVE BOOSTER 120 DRIVE BOOSTER 250 Approx. 500 g Approx. 650 g

* the maximum duration of storage is equal to 2 years from the date of manufacture marked on the label on the lubricant tank. The grease cartridge and battery pack can still be used for a 12 month time setting if they are started within 2 years of the date of manufacture.

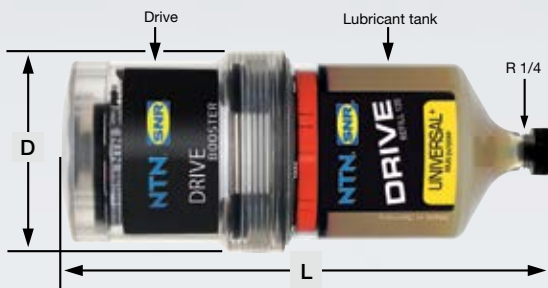

Type	Volume (cm ³)	Diameter D (mm)	Total length L (mm)
REFILL 120	120	71	165
REFILL 250	250	71	215

Adjustment of flow	LUBER DRIVE 120				LUBER DRIVE 250			
	1	3	6	12	1	3	6	12
Flow \ setting (months)								
Lubricant / day (cm ³)	4	1.3	0.7	0.3	8.3	2.8	1.4	0.7
Lubricant / week (cm ³)	28	9.3	4.7	2.3	58.3	19.4	9.7	4.9
Pump strokes / day	8	2 to 3	1 to 2	< 1	16 to 17	5 to 6	2 to 3	1 to 2
Pump strokes / week	56	18 to 19	9 to 10	4 to 5	116 to 117	39 to 40	19 to 20	9 to 10

1 pump stroke (grease gun) distributes: 0.5 cm³/ piston displacement

Volumetric pump with level detection and pressure switch designed for use with LUBSO INJECTOR injectors screwed on LUBSO MANIFOLD bars.

The MANUAL model is to be controlled by an external PLC.
The AUTOMATIC model is managed by its own built-in controller.

Main components:

Transparent plastic tank, electric gear pump, level sensor (NO = Normally Open when empty), pressure indicator, pressure switch (NO = Normally Open) and user interface board

Description

Compatible lubricant	Mineral oil
Viscosity of the lubricant at operating temperature	From 68 to 320cSt (320 to 1480 SUS)
Storage temperature	- 20°C to + 60°C
Operating temperature % relative humidity	+5°C to + 60°C max. 90%
Level of protection	IP55
Continuous sound level	< 70 DB (A)

Voltage / Frequency	110V / 50 Hz	110V/ 60 Hz	230V/ 50 Hz	230V/ 60 Hz
Power absorbed	162W	155W	150W	148W
Nominal current	1,48A		0.69A	0.70A
Pump flowrate	180 cm ³ /min (10.98 cu.in)	220 cm ³ /min (13.42 cu.in)	180 cm ³ /min (10.98 cu.in)	220 cm ³ /min (13.42 cu.in)
Rpm	2900	3500	2900	3500
Maximum pressure	30 bars (411 psi)			
Tank capacity	3 Litres (0.66 gallons)			
By-pass threshold	25 bars (367.5 psi)			
Pressure switch setting	18 bars (264.6 psi)			
Cycle time	10 to 120 secondes per increment of 10 secondes			
Programming and display screen	4 alphanumeric characters			
Pause time	1 to 60 minutes per increment of 1 minute			
Weight	4 kg (8.8 lb)			
Other available functions	Oil level and cycle control Cycle counter Stand-by setting (cycle and pause) Push-in connector (1/4 x 6 mm) at the outlet			

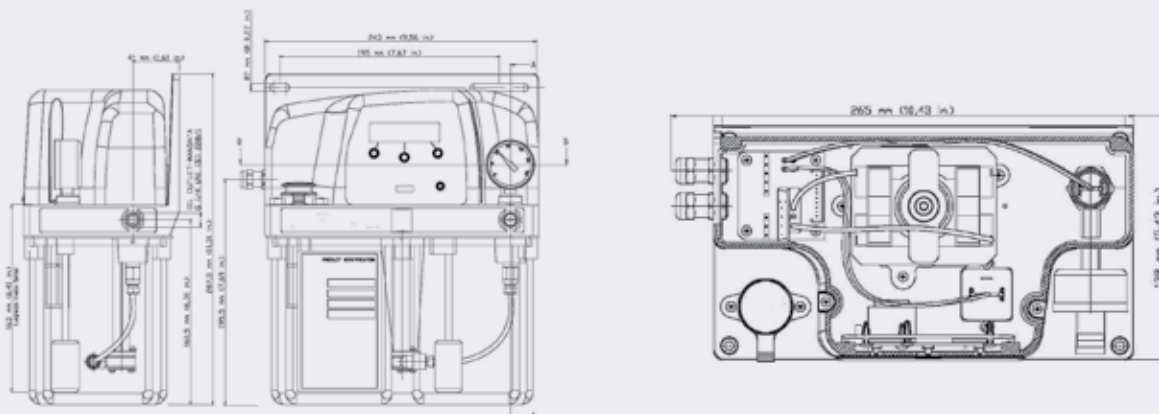

5- TECHNICAL DATAS FOR PRODUCTS

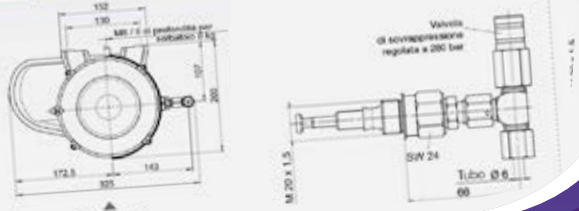

LUBSO MANIFOLD (NUMBER OF OUTLETS) OUT

> P 35

Several sizes of distribution bars

Number of outlets	A	B	Weight (g)
1	40	20	21
2	61	41	33
3	82	62	44
4	103	83	58
5	124	104	68
6	145	125	80

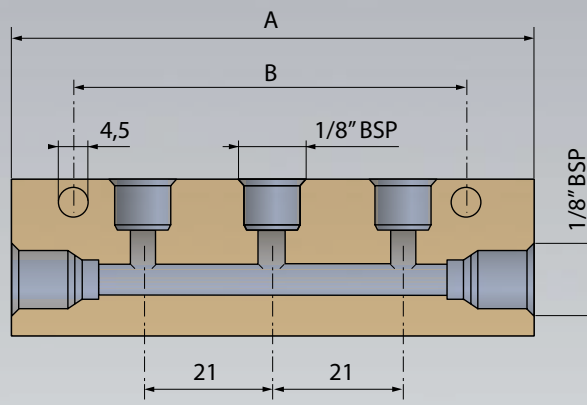

LUBSO INJECT (DISCHARGE VOLUME)

> P 35

Available discharge volume (in cm³): 0.03, 0.06, 0.1, 0.2, 0.3, 0.5, 0.75, 1

Capacity		Discharge volume	
Characteristics		0.03 to 0.16 cm ³	0.20 to 1 cm ³
Minimum pressure		12 bars (175 psi)	
Maximum pressure		50 bars (725 psi)	
Maximum pressure at the point of discharge (psi)		4 bars (58)	2.5 bars (36)
Lubricants	Oil viscosity	32 to 2000 cSt	
	Grease grade	NLGI 0	Not suitable for grease
Minimum discharge time (seconds)*	Oil 32 - 250 cSt	10	
	Oil 260 - 1000 cSt	200	
	NLGI grade 0 grease	200	Not suitable for grease

* Discharge times differ depending on the volumes of the injectors mounted on one single bar.

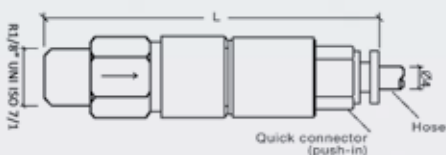

L : 0,03 à 0,5 cc = 60 mm
0,75 à 1 cc = 74 mm

Electric pump with integrated tank and a piston pump actuated by a camshaft, designed for use with LUBSO DISTRIBUTOR

The MANUAL model is to be controlled by an external PLC.
The AUTOMATIC model is managed by its own built-in controller.

Main components:

Transparent plastic tank, level sensor (NO = Normally Open if empty), pressure indicator

Description

Compatible lubricant	Mineral oil or grease	
Lubricant characteristics	Max. oil viscosity: 40 cSt NLGI grade 2 grease max.	
Operating temperature	- from 35°C to 70°C (from -31°F to 158°F)	
Level of protection	IP65	
Continuous sound level	< 70 DB (A)	
Voltage	12 V	24 V
Nominal current off load	0.8 A	0.4 A
Nominal current on load	2.2 A	1.1 A
Pump flow*	0.12 / tour	
Speed (rpm)	15	
Maximum pressure	280 bars (3830 psi)	
Tank capacity	4 kg (8.82 lb)	
By-pass threshold	25 bars (367.5 psi)	
Pressure switch setting	18 bars (264.6 psi)	
Tank position	Vertical	
Camshaft direction of rotation	Anti-clockwise	
Programming of operating cycle	0 to 16 minutes	
Programming of pause cycle	30 minutes to 8 hours	
Weight	6 kg	

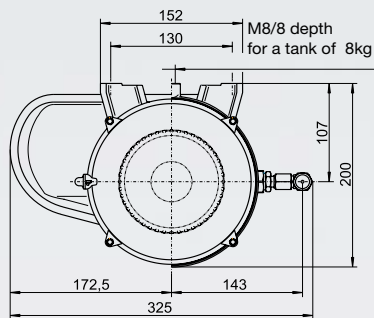
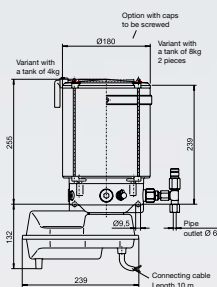

▲
Top view

Each pump unit is supplied with one pump. One or two additional pumps can be added to the unit in order to increase flow or to create 1 or 2 additional independent circuits using the same unit. Contact us for details.

PRODUCT REFERENCE
LUBSO PUMPING ELEMENT DC

Fixed 12/24 V pump, 0.12 cm³ / stroke

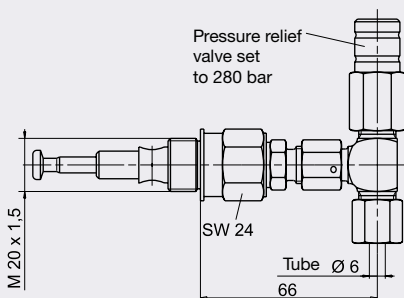

PRODUCT REFERENCE
LUBSO PUMPING ELEMENT DC AJUSTABLE

12/24 V pump
Variable flow: 0.04 - 0.12 cm³ / stroke

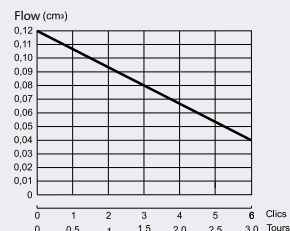
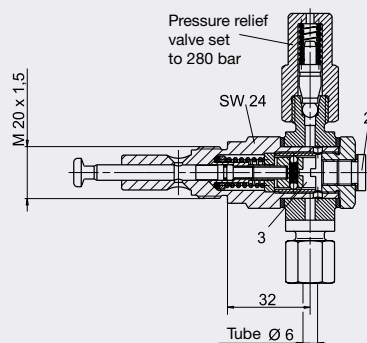

5- TECHNICAL DATAS FOR PRODUCTS

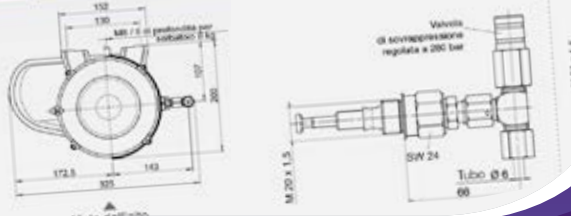

LUBSO MULTIPULSE AC 110/230V (50 OU 60) HZ MAN

> P 37

Electric pump with integrated tank and a piston pump actuated by a camshaft, designed for use with LUBSO DISTRIBUTOR. The MANUAL model is to be controlled by an external PLC. The AUTOMATIC model is managed by its own built-in controller

Main components:

Transparent plastic tank, level sensor (NO = Normally Open if empty)

Description

Compatible lubricant	Grease NLGI 2			
Operating temperature	From -25°C to + 80°C (from -13°F to 176°F)			
Level of protection	IP65			
Continuous sound level	< 70 dB (A)			
Voltage / Frequency	110 V / 50 Hz	110 V / 60 Hz	230 V / 50 Hz	230 V / 60 Hz
Nominal current off load	0.2 A		0.1 A	
Nominal current on load	0.3 A		0.2 A	
Pump flow rate	2.8cm ³			
Rpm	20			
Number of outlets (pump)	1 (as standard) to 3			
Maximum pressure	280 bars (4060psi)			
Adjustment of the by-pass (safety)	320 bars			
Tank capacity	5 litres			
Control	Using an external signal : electrical switch, PLC, etc.			
Camshaft direction of rotation	Anti-clockwise (indicated on the pump)			
Sound level	< 70 dB (A)			
Net weight	7 kg (15.43 lb)			
Other available functions	For operation with oil, please contact us			
Position of the tank	Vertical			

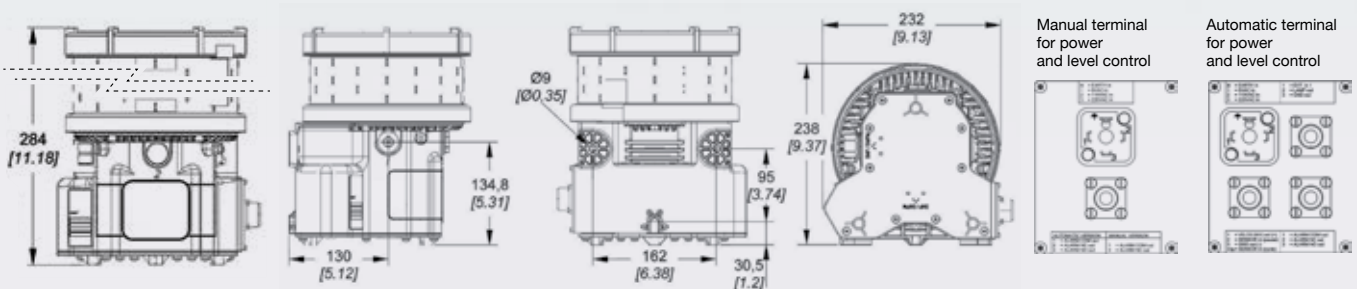

- Each pump unit is supplied with one pump. One or two additional pumps can be added to the unit in order to increase flow or to create 1 or 2 additional independent circuits using the same pump unit. Contact us for details

LUBSO PUMPING ELEMENT AC

> P 38

Additional pump for LUBSO MULTIPULSE, AC with fixed flow of 0.14 cm³ (i.e. 2.8cm³/min)

LUBSO DISTRIBUTOR (NUMBER OF OUTLETS) OUT

> P 36

Progressive distributor with multiple outlets, each with a flow of 0.2 cm³ (0.012 cubic inches) per cycle. Each individual outlet of the distributor can be blocked in order to transfer its flow to the next adjacent outlet.

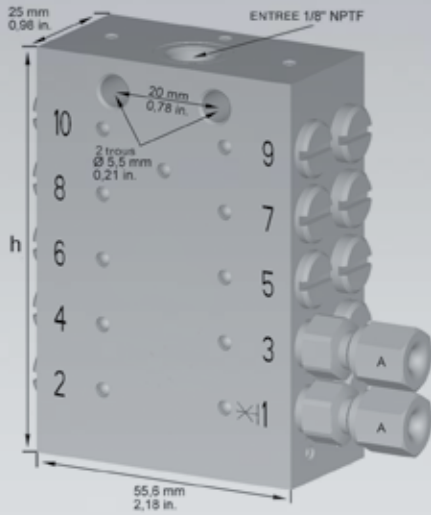

Min. pressure	20 bars (300 psi)
Max. pressure	300 bars (4 400 psi)
Max. number of cycles per minute	625
Operating temperature	-10° to 70° C (14 to 158° F)
Min. lubricant viscosity	32 cSt
Max. grease grade	NLGI 2
Material	zinc plated

Equipped with outlet connectors (A) with dia. 6 mm.

Type	Number of outlets	Height x (mm)	Height x (inches)
6 outlets	1 to 6	60	2.36
8 outlets	7 to 8	75	2.95
10 outlets	9 to 10	90	3.54
12 outlets	11 to 12	105	4.13

LUBSO ELECT INDICATOR - TECHNICAL DATA

> P 36

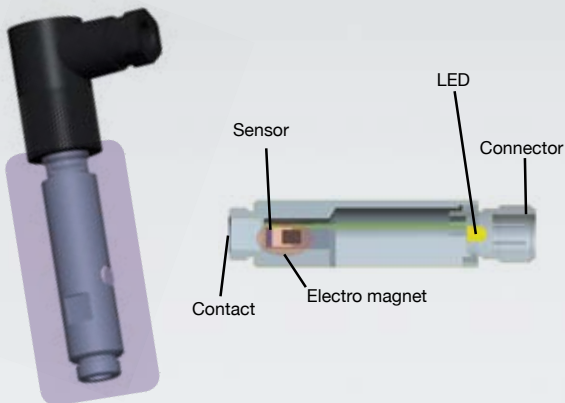

Material	AISI 316
Max. cycles/ minute	1000
Voltage	8/28 V DC
IP Protection grade	IP 67
Temperature (°C)	-10°C / +60°C
Connector	M12x1
Output signal	NPN 2A N.O - PNP 0,7A N.O.
Max. pressure at the sensor	400 bar

LUBSO VISUAL INDICATOR - TECHNICAL INFORMATIONS

> P 36



Length	44,7 mm
Diameter	14 mm
Thread for distributor fixation	M11x1

LUBSO MULTIPULSE AC FIXING KIT

> P 36

Kit containing a bent rigid tube and 2 special attachment screws, exclusively to fit any LUBSO DISTRIBUTOR dosing unit with 6 - 12 outlets under the base of the MULTI'PULSE AC pump.

5- TECHNICAL DATAS FOR PRODUCTS

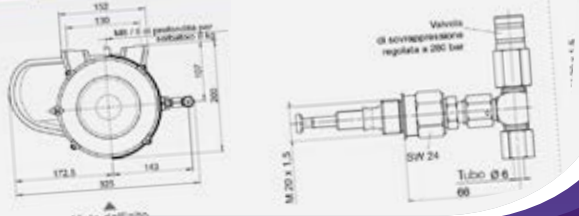

Reference : LUBSO AIRPULSE (24 OR 110) V (50 OR 60) HZ (NUMBER OF OUTLETS) JET > P 39

Set of pneumatic micro-pumps whose cycle time is controlled by a central unit. Each micro-pump is connected to a hose.

Technical data

Voltage	24 V DC or 110 V AC
Frequency	50 Hz / 60 Hz
Power	10 W
Allowable air pressure	5 to 8 bars
Number of outlets	1 to 8
Micro-pump flow	5 to 30 mm ³
Standard settings	7 – 15 – 30 mm ³
Level of protection	IP 44
Lubricant	Mineral oil
Viscosity	32 to 220 cSt
Tank capacity	1 litre
Hose length	2 metres
Operating temperature	From -5°C to +55°C
Output signal	Alarm signal relay 250 V max, 1 A (N.O. / N.C.)

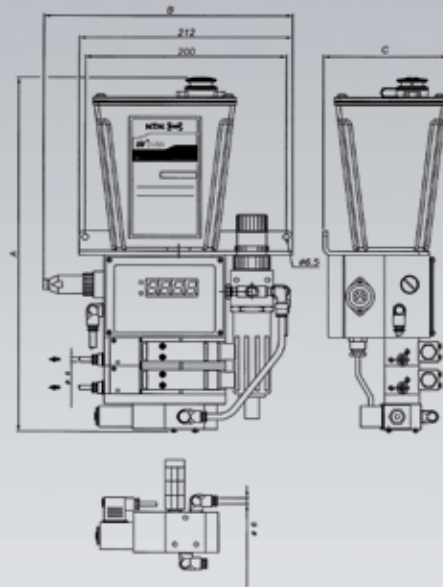

Number of outlets	Height (A) mm (inches)	Width mm (inches)	Depth mm (inches)
1	331 (13.03)	270 (10.62)	125 (4.92)
2	359 (14.13)		
3	387 (15.23)		
4	415 (16.33)		
5	448 (17.43)		
6	471 (18.53)		
7	499 (19.63)		
8	527 (20.73)		

ACCESSORIES

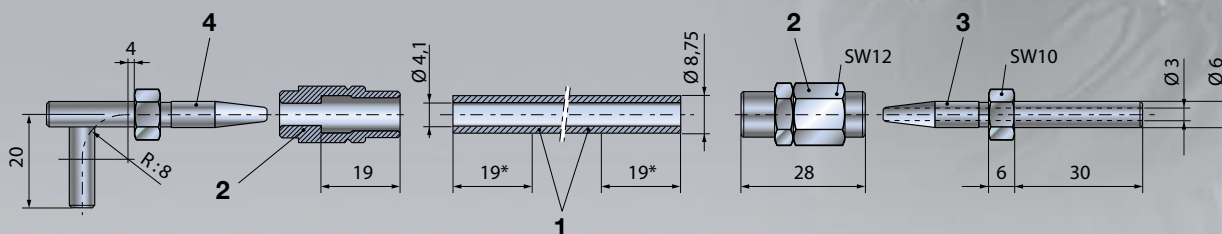

FLEXIBLE HOSE ▶ ITEM (1)

Reference : LUBSO HOSE HP 8MM 25M

> P 37

Flexible Polyurethane hose 100 R 7 Standard DIN 20021 in 25 metre coils
Construction: Flexible reinforced with a polyester braid and coated with super polyamide

Inner diameter	Outer diameter	Pressure (bars)			Temperature	Min. bend radius (mm)	Weight (g / m)
		Service	Test	Rupture			
mm (inches)	mm				-40 to +100°C	40	40
4,1 (1/8)	8.75	325	400	800	- 40°F to + 212°F		

INSERTS ▶ ITEM (2), (3) & (4)

Reference : LUBSO INSERT

> P 37

Insert and collar for LUBSO HOSE HP 8 MM 25 M

Reference	DIN	L	a	b
LUBSO COLLAR & INSERT ST L 38 x D6 (2 & 3)	4	20		
LUBSO COLLAR & INSERT 90D L 38 X D6 (2 & 4)	4		2	21

Reference : LUBSO HOSE (OUTER DIAMETER) MM 25 M

> P 34

Flexible clear nylon hose supplied in 25 metre coils

Reference	Dimensions (mm)	Max. pressure		Service temperature interval	Weight / Metre (g)
		bars	psi		
LUBSO HOSE 4 MM 25M	4 X 3	30	420	-70° to +100° C -94°F to +230°F	6
LUBSO HOSE 6 MM 25M	6 X 4,5	30	420		6



5- TECHNICAL DATAS FOR PRODUCTS

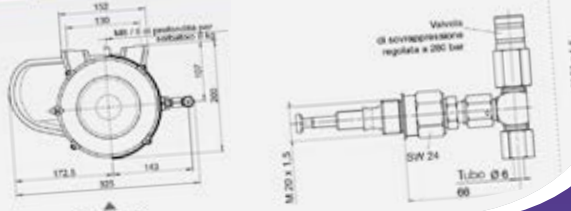

LUBSO PUSHIN CONNECTOR (INCHES) X 4 MM

> P 35 & 37

Quick connector (Push-in)

Reference	F	Dimensions in mm						
		Outer diameter of the tube	Ch	Ch1	P	L	D	E
LUBSO PUSHIN CONNECTOR 1/8 x 4MM	1/8	4	10	3	6	18	3.1	14

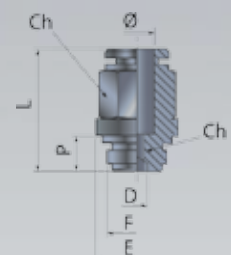

LUBSO CONNECTOR 1/8 X 6MM

> P 37

1/8" standard connector, (for smooth end-pieces, dia. 6 mm) DIN

Connector diameter (d)	Dimensions in mm					
	Outer diameter of the tube (d2)	d1	h	i	L	ch1 = ch2
LUBSO CONNECTOR 1/8 x 6 MM	6	14	8	8.5	23	14

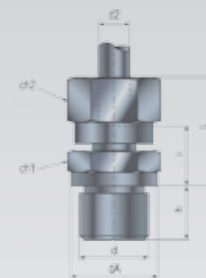

LUBSO HOOK LUBSO HOOK (NUMBER OF HOSES) DIA (HOSE DIAMETER)

> P 35 & 37

Attachment flange for DIN 72573 hoses

e=1 min	Dimensions in mm					
Connector diameter (d)	Number of hoses	Number of attachment screws	Tube diameter (D)	A	B	d1
LUBSO HOOK 1 DIA 4	1	1	4	18	1	4.8
LUBSO HOOK 2 DIA 4	2	1	4	33	1	4.8
LUBSO HOOK 3 DIA 4	3	1	4	39	1	4.8
LUBSO HOOK 1 DIA 6	1	1	6	20	1	4.8
LUBSO HOOK 2 DIA 6	2	2	6	38	1	4.8
LUBSO HOOK 3 DIA 6	3	2	6	45	1	4.8
LUBSO HOOK 1 DIA 8	1	1	8	22	1	4.8
LUBSO HOOK 2 DIA 8	2	2	8	42	1	4.8
LUBSO HOOK 3 DIA 8	3	2	8	51	1	4.8

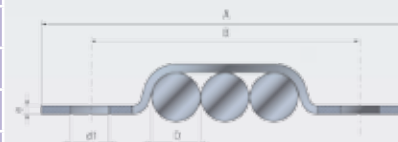
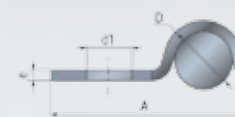

LUBSO SCREW M4X10

> P 35 & 37

Self-tapping screw for attaching LUBSO HOOK

Reference	Diameter d mm (inches)	L mm (inches)
LUBSO SCREW M4X10	M4 (0.157)	10 (0.393)



CONTACT PERSON _____

- Company/site
- Name/position
- Type of industry (e.g. metallurgy, paper, food, etc.)

ENVIRONMENT DATA _____

- Ambient temperature (°C) Min. Max.
- Specific conditions (e.g. ATEX area, humid environment, vibrations, etc.).....

MACHINE TO BE LUBRICATED _____

- Type of machine
- Type of oil used (viscosity, name, brand)
- Or types of grease used (grade, name, brand).....

• **Nombre de points à lubrifier :**

TYPE OF LUBRICATION POINTS	QUANTITY	FLOW PER POINT
Bearing unit		
Bearing		
Axis		
Gears		
Other		
Total working flow (for circulating oil)		

- Lubrication system used
 (Volume / IN’PULSE, Progressive / MULTI’PULSE, Air-oil / AIR’PULSE, Dual line / DUO’PULSE, Circulation)

- Power supply for the lubrication system
 Voltage : A.C./D.C. :

- Level control
 Yes/No If yes, specify visual electric

- Additional details (fill out if necessary)

- ▶ Please return this questionnaire filled out to:
- your NTN-SNR distributor
 - your NTN-SNR ROULEMENTS contact person
 - expertsandtools@ntn-snr.com



You can increase the operational effectiveness of your activity with our «field» experts by:

- Reducing your maintenance costs
- Improving the quality of your operations
- Optimising the service life of your equipment

NTN-SNR can:

- Provide training on practical and theoretical aspects
- Provide technical assistance
- Demonstrate maintenance products
- Renovate bearings and machine tool spindles
- Provide rapid bearing diagnostics
- Rent maintenance tools
- Audit your industrial maintenance organisation



Distributed by:

