

Rotary Seals

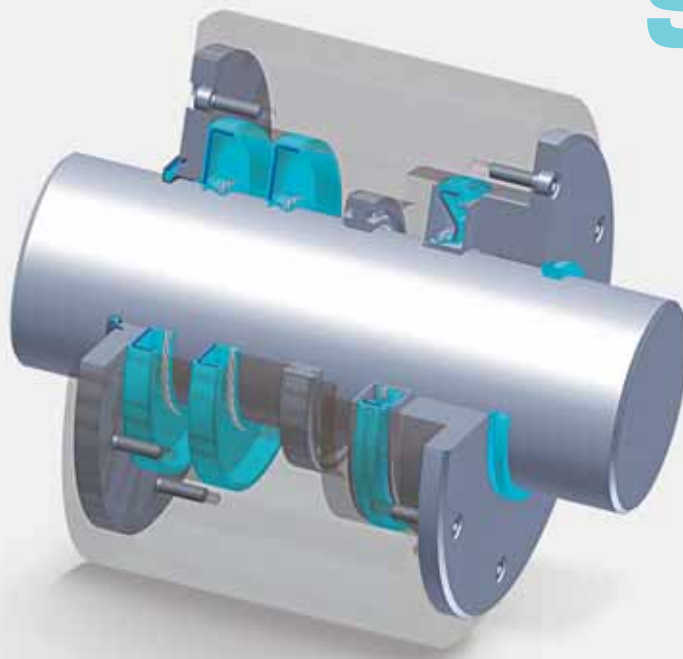

Your Partner for Sealing Technology



Your Partner for Sealing Technology

Trelleborg Sealing Solutions is a major international sealing force, uniquely placed to offer dedicated design and development from our market-leading product and material portfolio: a one-stop-shop providing the best in elastomer, thermoplastic, PTFE and composite technologies for applications in aerospace, industrial and automotive industries.

With 50 years of experience, Trelleborg Sealing Solutions engineers support customers with design, prototyping, production, test and installation using state-of-the-art design tools. An international network of over 70 facilities worldwide includes 25 manufacturing sites, strategically - positioned research and development centers, including materials and development laboratories and locations specializing in design and applications.

Developing and formulating materials in-house, we utilize the resource of our material database, including over 2,000 proprietary compounds and a range of unique products.

Trelleborg Sealing Solutions fulfills challenging service requirements, supplying standard parts in volume or a single custom-manufactured component, through our integrated logistical support, which effectively delivers over 40,000 sealing products to customers worldwide.

Facilities are certified to ISO 9001:2000 and ISO/TS 16949:2002. Trelleborg Sealing Solutions is backed by the experiences and resources of one of the world's foremost experts in polymer technology: the Trelleborg Group.

ISO 9001:2008

ISO/TS 16949:2009

The information in this brochure is intended to be for general reference purposes only and is not intended to be a specific recommendation for any individual application. The application limits for pressure, temperature, speed and media given are maximum values determined in laboratory conditions. In application, due to the interaction of operating parameters, maximum values may not be achieved. It is vital therefore, that customers satisfy themselves as to the suitability of product and material for each of their individual applications. Any reliance on information is therefore at the user's own risk. In no event will Trelleborg Sealing Solutions be liable for any loss, damage, claim or expense directly or indirectly arising or resulting from the use of any information provided in this brochure. While every effort is made to ensure the accuracy of information contained herewith, Trelleborg Sealing Solutions cannot warrant the accuracy or completeness of information.

To obtain the best recommendation for a specific application, please contact your local Trelleborg Sealing Solutions marketing company.

This edition supersedes all previous brochures.
This brochure or any part of it may not be reproduced without permission.

© All trademarks are the property of Trelleborg Group.
The turquoise color is a registered trademark of Trelleborg Group.
© 2009, Trelleborg Group. All rights reserved.

Rotary Seal

General description	4
Radial oil seal	9
The Seal	11
Design instruction Shaft	13
Working parameters	20
Standard types of rotary seals	26
Trelleborg Sealing Solutions type TRA	27
Trelleborg Sealing Solutions type TRE	50
Trelleborg Sealing Solutions type TRC	63
Trelleborg Sealing Solutions type TRD	70
Trelleborg Sealing Solutions type TRB	75
Trelleborg Sealing Solutions type TRF	83
Special types of rotary seals	86
Trelleborg Sealing Solutions types TRD_A / TRD_B	87
Trelleborg Sealing Solutions type TRU - medium pressure oil seal	89
Trelleborg Sealing Solutions type TRP - medium pressure oil seal	93
Trelleborg Sealing Solutions type TRQ - medium - high pressure oil seal	96
Trelleborg Sealing Solutions type TRK	98
Trelleborg Sealing Solutions type TRG	102
Rotary and axial seal combination	106
Product description	108
Combined rotary shaft seal	109
STEFA standard APJ types	110
STEFA 1B/APJ and 2B/APJ types - housing as per DIN 3760-3761	112
Trelleborg Sealing Solutions types TRJ/TRL Fibre reinforced seals	114
End cover	127
Trelleborg Sealing Solutions type YJ 38	129
Trelleborg Sealing Solutions type YJ 39	133
Shaft repair kit	135
Installation recommendation, metric sizes	139
Installation recommendation, inch sizes	141
Cassette seal	147
General	149
System 500	149
System 3000	150
System 5000	150
Material	153
Application	154
Installation	157

Rotary Seal

V-Ring	159
General	161
Materials	162
Installation	165
Dimension table, V-Ring type A	168
Dimension table, V-Ring type S	172
Dimension table, V-Ring type L/LX	174
Dimension table, V-Ring type RM/RME	177
Dimension table, V-Ring type AX	182
GAMMA seal	185
GAMMA seal type TBP/RB	191
GAMMA seal type TBR/9RB	194
Axial shaft seal	197
General	199
Applications	201
Materials	202
Installation recommendation, type I, internal sealing, for oil and grease	204
Installation recommendation, type A, external sealing, for grease only	207
Turcon® Varilip® PDR	211
Introduction	213
Description	213
Turcon® Varilip® PDR Product Range	214
Materials	216
Technical Data	218
Design Guidelines	225
Installation Requirements	227
Packaging	227
Storage	227
Fitting Instructions	228
Installation Recommendations	229
Turcon® Varilip® PDR Size Ranges	230
Ordering Information	238
Turcon® and Zurcon® - Elastomer energized	241
Turcon® Roto Glyd Ring®	243
Installation of Turcon® Roto Glyd Ring®	246
Installation recommendation - external sealing	250
Installation recommendation - internal sealing	254
Special solutions for rotary applications	258
Zurcon® Roto Glyd Ring S	259
Installation of Zurcon® Roto Glyd Ring S	265
Installation recommendation - shaft sealing	116
Installation recommendation - bore sealing	271





Rotary Seal

Turcon® rotary seals - spring energized	275
Turcon® Roto Variseal®	277
Installation of Turcon® Roto Variseal®	279
Installation recommendation	281
Mechanical Face Seals	285
Description	287
Applications	288
Materials	289
Design Instructions	290
Installation Instructions	291
Installation Recommendations for Type DO Bearing Steel	292
Installation Recommendations for Type DO in Cast Iron	297
Installation Recommendations for Type DF Bearing Steel	300
General quality criteria and storage guidelines	302
Quality criteria	302
Storage and shelf live of polymer sealing material	302

Rotary Seal

■ GENERAL DESCRIPTION

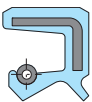
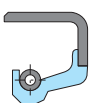

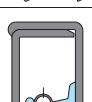
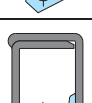
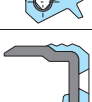
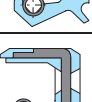
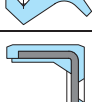









Rotary seals selection criteria - Radial oil seals

Family	Seal				Installation	Outer cover		Dust lip		Technical data*	
	Profile	Page	TSS type	Standard (Characteristics)	Size range mm	Rubber Coated	Metal	With	Without	Speed m/s	Pressure MPa max.
Radial Oil Seals 		27	TRA	ISO 6194/1 DIN 3760 Type A	4 - 500	X			X	30	0.05
		50	TRE	ISO 6194/0 DIN 3760 Type AS	6 - 380	X		X		30	0.05
		63	TRC	ISO 6194/1 DIN 3761 Type B	6 - 550		X		X	30	0.05
		70	TRD	ISO 6194/1 DIN 3761 Type BS	15 - 400		X	X		30	0.05
		75	TRB	ISO 6194/1 DIN 3761 Type C	20 - 760		X		X	30	0.05
		83	TRF	ISO 6194/1 DIN 3761 Type CS	35 - 600		X	X		30	0.05
		87	TRD_A	Combined seal Rubber at backface	On demand	Half	Half	X		30	0.05
		87	TRD_B	Combined seal Rubber at frontface	On demand	Half	Half	X		30	0.05
		89	TRU	Pressure seal	8 - 120	X		X		10	0.50

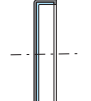
* The data below are maximum values and cannot be used at the same time. The max. pressure depends on temperature.

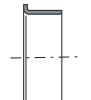
Rotary Seal









Radial oil seals - End covers - Shaft repair kit - Cassette seals

Family	Seal				Installation	Outer cover		Dust lip		Technical data*	
	Profile	Page	TSS type	Standard (Characteristics)	Size range mm	Rubber Coated	Metal	With	Without	Speed m/s	Pressure MPa max.
Radial Oil Seals 		93	TRP	Pressure seal	11 - 365	X		X		10	0.5
		96	TRQ_D	Pressure seal	15 - 55	X		X		5	1.0
		98	TRK	Low friction, no spring	4 - 70	X			X	10	Without
		102	TRG	Low friction, no spring	4 - 70		X		X	10	Without
		114	TRJ/TRL	Fabric reinforced	100 - 1954	X			X	10	0.05
End Covers 		129	YJ38	End cover	16 - 230	X					0.05
		133	YJ39	End cover	22 - 270	Half	Half				0.5
Shaft Repair Kit 		137	TS	Sleeve	12 - 200		X				-
Cassette Seals 		149	TC5	System 500	90 - 320		X			10	0.05
		150	TC3	System 3000	130 - 150		X	X		4	0.05
		150	TC0	System 5000	On demand		X	X		15	0.05

* The data below are maximum values and cannot be used at the same time. The max. pressure depends on temperature.







Rotary Seal

V-Rings

Family	Seal					Installation	Retention/Clamping possibilities		Technical data*	
	Profile	Page	TSS designation	FORSHEDA-type	Standard (characteristics)	Size range mm	With clamping band	With axial retention	Speed m/s	Pressure MPa max.
V-Ring 		168	VA	A	V-Ring Standard	2.7 - 2010		X	10	Without
		172	VS	S	V-Ring Extended body	4.5 - 210		X	10	Without
		174	VL	L	V-Ring Small profile	105 - 2025		X	10	Without
		174	LX	LX	V-Ring Large diameter rigid lip	135 - 2025		X	10	Without
		177	RM	RM	V-Ring Standard with clamping band, extended body	300 - 2010	X		10	Without
		177	VB	RME	V-Ring Standard with clamping band	300 - 2010	X		10	Without
		182	AX	AX	V-Ring Large diameter, flexible lip	200 - 2020		X	10	Without

* The data below are maximum values and cannot be used at the same time. The max. pressure depends on temperature.

GAMMA seals, Axial shaft seals

Family	Seal				Installation	Technical data*	
	Profile	Page	TSS type	Standard (Characteristics)	Size range mm	Speed m/s	Pressure MPa max.
GAMMA Seals 		191	TBP	GAMMA Seal standard	10 - 225	20	Without
		194	TBR	GAMMA Seal with labyrinth	15 - 108	20	Without
Axial Shaft Seals 		200	TAI	Axial shaft seal inside sealing	10 - 100	30	0.01
		200	TAA	Axial shaft seal outside sealing	10 - 114	15	0.01

* The values given are maximums. Maximum values should not be combined. The max. pressure depends on temperature.





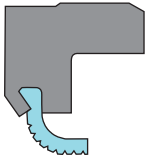
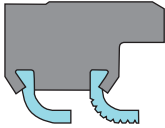
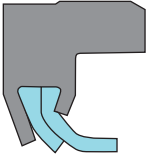
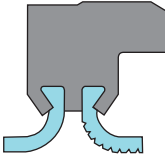
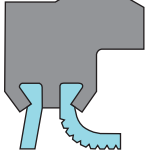



Rotary Seal

Turcon® Varilip® PDR

Seal	Description
Type A/Type 1 	Type A - is a single lip seal suitable for use in standard industrial applications up to a pressure of 0.5 MPa (73 psi) where an elastomer radial shaft seal would be unable to withstand the temperature, friction, medium or poor lubrication. Allows sealing at surface speeds up to 90 m/s (17,721 ft/min) with sufficient cooling and lubrication of the sealing lip.
Type B/Type 3 	Type B - is the preferred choice for applications in which a high seal integrity is demanded or where contaminated media are to be sealed. This type offers a back-up sealing lip to provide secondary sealing. Pressure limit is 0.5 MPa (73 psi).
Type C/Type 4 	Type C - can be used for applications involving higher pressures for which a simple elastomer radial shaft seal can no longer be considered. Due to reinforcement of the sealing lip, pressures up to 1 MPa (145 psi) are possible, e.g. as pump, shaft or rotor seals.
Type D/Type 5 	Type D - can be subjected to pressure from both sides. Pressure differential of up to 0.5 MPa (73 psi) is permissible. The separation of two different media using a single seal is possible. The second lip can also take on the function of a wiper or dust lip.
Type G/Type 6 	Type G - is similar to Type D but has a non-contacting environmental sealing element rather than a full lay-down lip. This provides effective sealing against the ingress of dust and dirt into the system while also ensuring torque and resulting power consumption are kept to a minimum.

Rotary Seal



Turcon® rotary seals

Family	Seal		Application	Standard	Size range	Function		Technical Data*			Material	Shaft
	Type	Page				Field of application	ISO/DIN	mm	Single acting	Double acting		
			°C	m/s	MPa max.						Standard seal material	Mating surface hardness
Turcon® seals Elastomer energized  I.S. = Inner Sealing O.S. = Outer Sealing	Turcon® Roto Glyd Ring® O.S. 	243	Rotary distributors Pivoting motors: - Mobile hydraulic - Machine tools	ISO 7425/1	8 - 2700	-	X	-45 to +200	1	30	Turcon® T10	>55 HRc
									2	20	Turcon® T40	>55 HRc
	Turcon® Roto Glyd Ring® I.S. 	243	Rotary distributors Pivoting motors: - Mobile hydraulic - Machine tools	ISO 7425/2	6 - 2600	-	X	-45 to +200	1	30	Turcon® T10	>55 HRc
									2	20	Turcon® T40	>55 HRc
Zurcon® Roto Glyd Ring® S  I.S. = Inner Sealing O.S. = Outer Sealing	Zurcon® Roto Glyd Ring® S I.S. 	261	For sealing shafts, axels and rotary transmission leadthroughs with slow rotary or ascillating movement	ISO 7425/1	10 - 2700	-	X	-45 to +100	6.5 MPa x m/s		Zurcon® Z51 Z52 Z80	>55 HRc
											Zurcon® Roto Glyd Ring® S O.S. 	261
Turcon® seals Spring energized 	Turcon® Roto Variseal® 	277	Rotary distributors Pivoting motors: - Pharmacy - Machine tools - Foodstuff - Industry - Chemical	-	5 - 2500	X	-100 to +200	2	15	Turcon® T40		
								2	5	Turcon® T78	>170 HB	

* The data below are maximum values and cannot be used at the same time. The max. pressure depends on temperature.

** Temperature range depends on choice of elastomer material.

Mechanical Face Seals

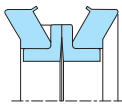
Family	Seal				Installation	Technical data*	
	Profile	Page	TSS type	Material	Size range mm	Speed m/s	Pressure MPa max.
Mechanical Face Seals 		292	TLDO	100cr6	45 - 886	2.2	1.5
				bearing steel	51 - 457	3.0	3.0
		300	TLDF	100cr6	59 - 492	3.0	0

* The values given are maximums. Maximum values should not be combined. The max. pressure depends on temperature.

Radial Oil Seal







■ RADIAL OIL SEAL

■ The Seal

General

Rotary shaft lip seals are components designed in a ring form, fitted between machine parts in relative rotation, with the function of separating oil or grease from the inside and dirt, dust, water etc. from the outside.

The rotary shaft seals are generally composed of an elastomeric diaphragm, shaped in a "lip form" and reinforced with a co-vulcanized metal insert. The sealing lip is energized with a "Garter Spring".

Seal design

The sealing lip design corresponds to the current state of art and is based on many years of experience in a wide range of application fields.

The sealing edge can either be ready molded or trimmed by mechanical cutting.

The total radial force of the sealing lip is given by elastomer pre-tension together with tensile spring force. The former depends on the deformation and elasticity of the rubber material, geometry of the sealing lip and interference between shaft and seal.

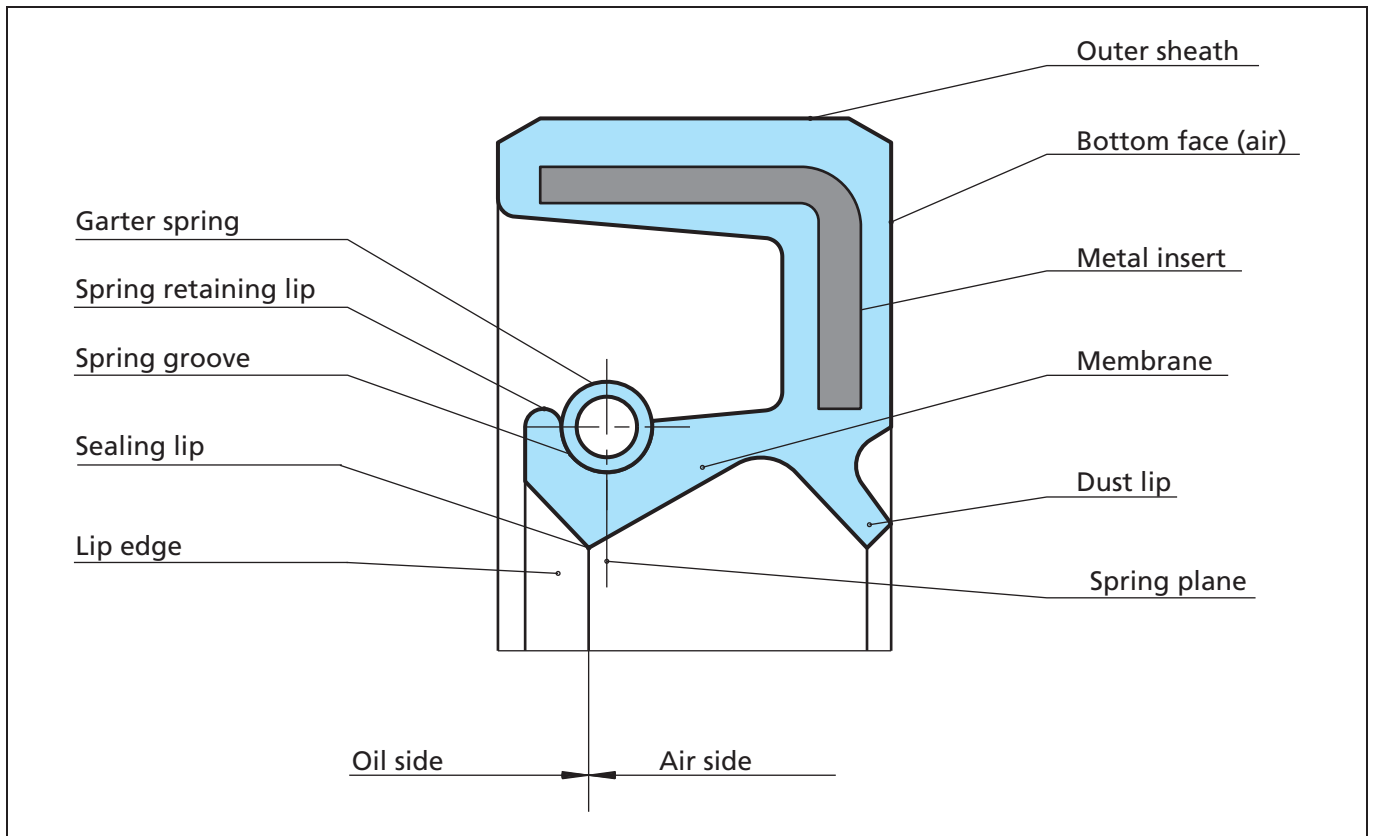

Figure 1 Designation for Rotary shaft lip seals (extract from ISO 6194)



Radial Oil Seal

Seal design

Outer sheath

Can be either flat or wavy, fitting in both cases into ISO H8 bore and the tolerance of the outer sheath is according to ISO 6194-1.

Metal insert

Is normally made of cold rolled steel sheet AISI 1008, DIN 1624. Environmental conditions may require another material, such as stainless steel AISI 304, DIN 1.4301.

If the seal is not rubber covered as for the seal type TRC, TRD, TRB and TRF, the metal insert O.D. tolerance is also according to ISO 6194-1. On request the O.D. can be delivered with sealing agent.

The case is normally made of cold rolled steel sheet AISI 1008, DIN 1624. Environmental conditions may dictate other materials, such as brass or stainless steel AISI 304, DIN 1.4301.

Table I Tolerance according to ISO 6194-1

Nominal outside diameter d_2	Diametral tolerance	
	Metal cased	Rubber covered
$D_2 \leq 50$	+ 0.20	+ 0.30
	+ 0.08	+ 0.15
$50 < D_2 \leq 80$	+ 0.23	+ 0.35
	+ 0.09	+ 0.20
$80 < D_2 \leq 120$	+ 0.25	+ 0.35
	+ 0.10	+ 0.20
$120 < D_2 \leq 180$	+ 0.28	+ 0.45
	+ 0.12	+ 0.25
$180 < D_2 \leq 300$	+ 0.35	+ 0.45
	+ 0.15	+ 0.25
$300 < D_2 \leq 530$	+ 0.45	+ 0.55
	+ 0.20	+ 0.30

Garter spring

Function

When rubber is exposed to heat, load or chemical action, it will gradually lose its original properties. The rubber is then said to have aged. The original radial force exerted by the sealing element will then diminish. The function of the garter spring is therefore to maintain the radial force.

Experiments have shown that the radial force must vary with the size and type of seal. Experiments have also clearly indicated the significance of maintaining changes in the radial force within narrow limits during the service life of the seal. Extensive investigations in the laboratory have formed the basis for defining the radial force.

The garter spring is closely wound and carries an initial tension. The total force exerted by the spring consists of the force required to overcome the initial tension and the force due to the spring rate. The use of a garter spring with initial tension provides the following advantages:

- as the sealing element wears, the total radial force from the initial tension will not change.
- by eliminating some of the initial tension by heat treatment, it can be adjusted to achieve the required radial force for the actual shaft diameter.
- the heat treatment of the spring takes place at a temperature above the operating thermal level of the seal, thus ensuring that the spring force will be stabilized. This procedure eliminates the risk that the original spring force will change during service.

Material

Spring steel SAE 1074, DIN 17223 is normally employed. If resistance to corrosion is required stainless steel AISI 304, DIN 1.4301 is used. Garter springs of bronze or similar materials are not recommended, since they tend to fatigue after long service life or as a result of exposure to high temperatures. In special cases the garter spring can be protected against fouling by means of a thin rubber hose.



■ Design instruction Shaft

Shaft

Surface finish, hardness and machining methods

The shaft design is of vital significance for the performance as well as for the useful life of the seal (see Figure 4). As a basic principle, the hardness of the shaft should be higher as peripheral speeds increase. The Standard DIN 3760 specifies that the shaft must be hardened at least 45 HRC.

As the peripheral speeds increase, the hardness must be increased and at 10 m/s a hardness of 60 HRC is required. The choice of a suitable hardness is dependent not only on the peripheral speed but also on such factors as lubrication and the presence of abrasive particles. Poor lubrication and difficult environmental conditions require a higher hardness of the shaft. DIN 3760 specifies a surface roughness of $R_t=1\ \mu\text{m}$ to $4\ \mu\text{m}$. Laboratory tests have however proved that the most suitable roughness is $R_t=2\ \mu\text{m}$ ($R_a=0.3\ \mu\text{m}$). Rougher as well as smoother surfaces generate higher friction, resulting in increased temperature and wear. We suggest a surface roughness of $R_t=2-3\ \mu\text{m}$ ($R_a=0.2-0.8\ \mu\text{m}$).

Measurements of friction and temperature have also shown that grinding of the shaft is the best method of machining. However spiral grinding marks may cause a pumping effect and leakage and plunge grinding should therefore be applied, during which even ratios between grinding wheel speed and work-piece should be avoided. Polishing of the shaft surface with polishing cloth produces a surface which causes higher friction and heat generated as compared with plunge grinding. In certain cases it maybe impossible to provide the necessary hardness, surface finish and corrosion resistance of the shaft. This problem can be solved by fitting a separate sleeve onto the shaft. If wear should occur, only the sleeve need to be replaced (see the chapter "Shaft Repair Kit").

Shaft run out

Shaft run out should as far as possible be avoided or kept within a minimum. At higher speeds there is a risk that the inertia of the sealing lip prevents it from following the shaft movement. The seal must be located next to the bearing and the bearing play be maintained at the minimum value possible. See Figure 2.

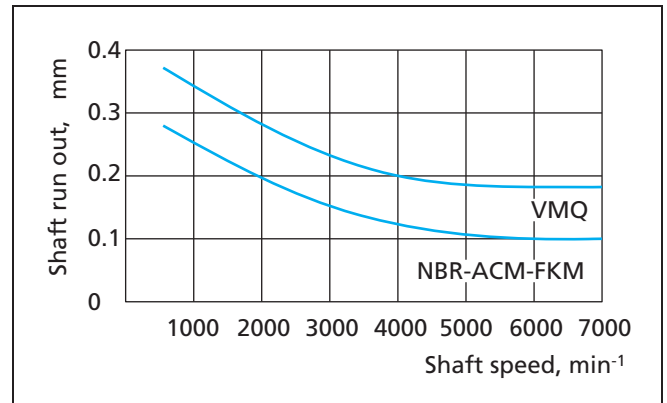

Figure 2 Shaft run out

Eccentricity

Eccentricity between shaft and housing bore centers should be avoided in order to eliminate unilateral load of the lip. See Figure 3.

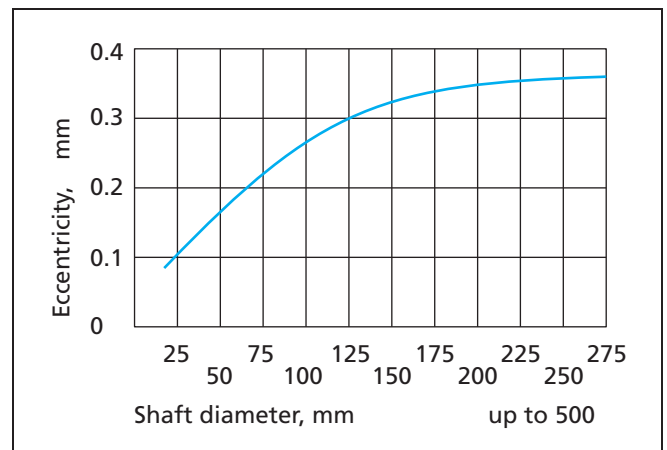

Figure 3 Eccentricity



Radial Oil Seal

Design instruction Shaft

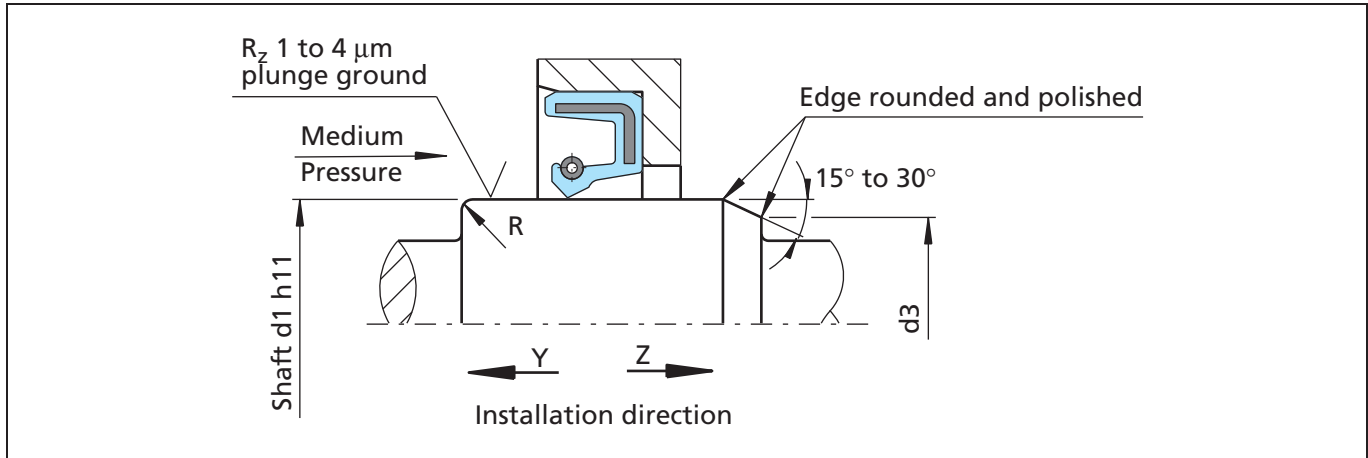

Figure 4 Installation of the Radial Oil Seal

Depending on the installation direction (Y or Z), a chamfer or radius on the shaft is recommended. The dimensions for this are shown in Figure 4 and Table II.

Table II Chamfer length for shaft end

d_1	d_3	R
< 10	$d_1 - 1.5$	2
over 10 to 20	$d_1 - 2.0$	2
over 20 to 30	$d_1 - 2.5$	3
over 30 to 40	$d_1 - 3.0$	3
over 40 to 50	$d_1 - 3.5$	4
over 50 to 70	$d_1 - 4.0$	4
over 70 to 95	$d_1 - 4.5$	5
over 95 to 130	$d_1 - 5.5$	6
over 130 to 240	$d_1 - 7.0$	8
over 240 to 500	$d_1 - 11.0$	12

Characteristics of the shaft surface

The running surface for oil seals is specified in DIN 3760/61. The surface should meet the following requirements:

Surface roughness	R_a	= 0.2 to 0.8 μm
	R_z	= 1 to 4 μm
	R_{max}	= 6.3 μm
Hardness	55 HRC or 600 HV, hardness depth min. 0.3 mm	

Surface roughness

The functional reliability and service life of a seal depends to a very great extent on the quality and surface finish of the mating surface to be sealed. Scores, scratches, pores, concentric or spiral machining marks are not permitted. Higher demands must be made on the surface finish of dynamic mating surfaces than to static mating surfaces.

The characteristics most frequently used to describe the surface microfinish, R_a , R_z and R_{max} , are defined in ISO 4287. These characteristics alone, however, are not sufficient for assessing the suitability in seal engineering. In addition, the material contact area R_{mr} in accordance with ISO 4287 should be considered. The significance of these surface specifications is illustrated in Figure 5. It shows clearly that specification of R_a or R_z alone does not describe the profile form accurately enough and is thus not sufficient for assessing suitability in seal engineering.

The material contact area R_{mr} is essential for assessing surfaces, as this parameter is determined by the specific profile form. This in term is directly depending on the machining process employed.

Surface profile	R_a	R_z	R_{mr}
closed profile form 	0.1	1.0	70%
open profile form 	0.2	1.0	15%

Figure 5 Profile forms of surfaces



Design instruction Housing bore

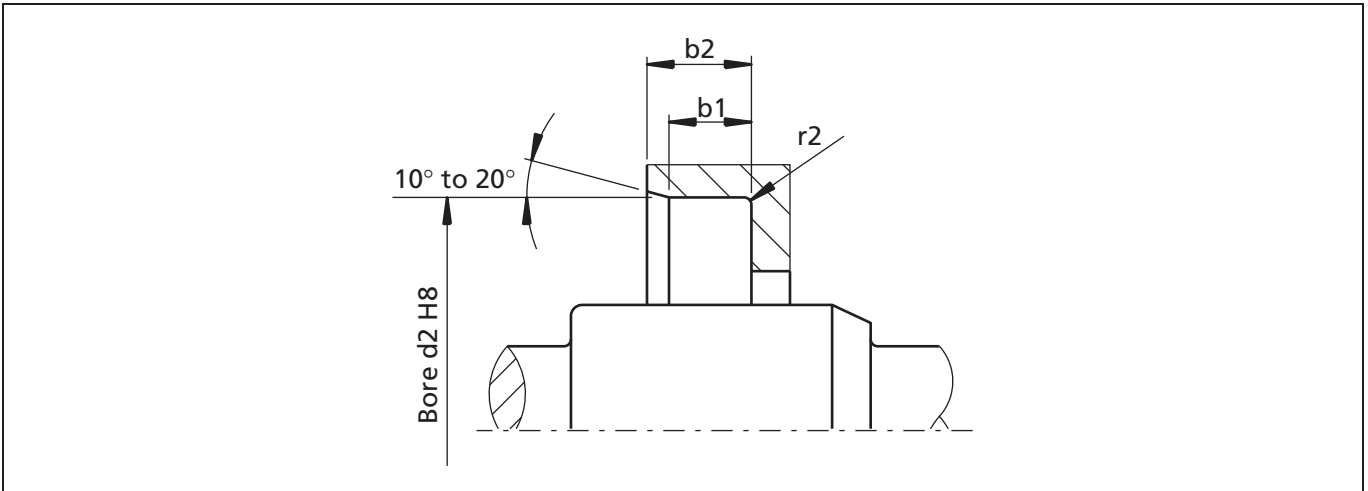

Figure 6 Installation depth and lead-in chamfer

Housing bore

For metric sizes the tolerances are in accordance with the German Standard DIN 3760 which provides a suitable press fit for the bore tolerance ISO H8. The inch sizes are in accordance with American Standards. In cases where the housing bore has a different tolerance the seal can be made to a suitable size. For bearing housings made of soft materials, e.g. light metals, and for bearing housings with thin walls, a special fit between the seal and the housing may be necessary. The tolerances for the seal and housing should then be determined by practical assembly trials. If a component such as a bearing is assembled through the housing bore for the seal, the bore may be damaged. In order to avoid damaging the bore, a seal with a larger outside diameter than that of the bearing should be selected.

Surface roughness of the housing

Values for the surface roughness in the gland are specified in ISO 6194/1.

General values:	R_a	=	1.6	-	6.3	μm
	R_z	=	10	-	20	μm
	R_{max}	=	16	-	25	μm

For metal/metal sealing or gas sealing, a good score-free and spiral-free surface finish is necessary. If the rotary shaft lip seal is bonded into the housing, ensure that no adhesive comes into contact with the sealing lip or the shaft.

Table III Housing dimensions

Ring Width b	b_1 ($0.85 \times b$) mm	b_2 ($b + 0.3$) mm	r_2 max.
7	5.95	7.3	0.5
8	6.80	8.3	
10	8.50	10.3	
12	10.30	12.3	0.7
15	12.75	15.3	
20	17.00	20.3	



Radial Oil Seal

Installation instructions

The following points must be observed when installing rotary shaft lip seals:

- Before installing, clean the installation grooves. Shaft and seal must be greased or oiled for rubber seals
- Sharp-edged transitions must either be chamfered or rounded or else covered
- When pressing in the seal, take care that the seal ring is not twisted
- The pressing force must be applied as close as possible to the outer circumference of the seal
- After installation, the seal must be concentric and at right angles to the shaft
- The end face of the mounting bore is generally used as the contact surface; the seal can also be fixed with a shoulder or a spacer washer.

Figure 7 shows various force fit situations of the rotary shaft lip seal with suitable installation tools or devices.

Dismantling and replacement

The dismantling of seals does not normally present any problems. A screwdriver or similar tool can generally be used. The seal will then be deformed. After repair or maintenance of a machine a new rotary shaft lip seal must always be installed, even if the old ones seem to be still usable. The sealing edge of the new seal must not ride on the old contact area on the shaft. This can be achieved by:

- replacement of shaft sleeves
- fitting the seal into the bore to a different depth
- rework of the shaft and assemble a wear sleeve (see the chapter "Shaft Repair Kit").

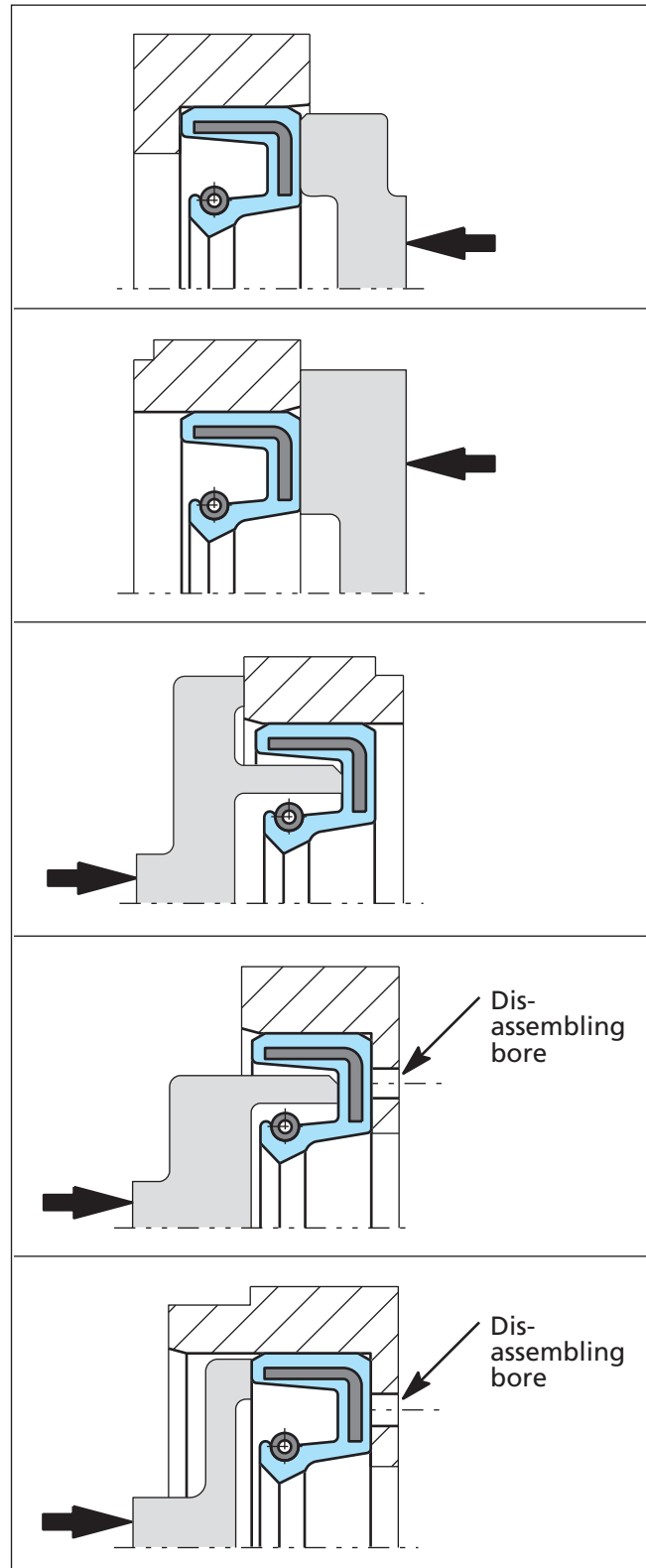

Figure 7 Installation aids for fitting rotary shaft lip seals



Sealing element

Compound

The material selected must take into account environmental conditions and function requirements.

Some of the requirements associated with environmental considerations are:

- Good chemical resistance
- Good resistance to heat and low temperature
- Good resistance to ozone and weathering

The functional demands include:

- High resistance to wear
- Low friction
- Low compression set
- Good elasticity

In addition, cost considerations render ease of processing a desirable feature. Trelleborg Sealing Solutions can supply the optimum material for each application.

To identify this contact your local Trelleborg Sealing Solutions marketing company.

Type and designations of materials

Nitrile rubber	(NBR)
Acrylic rubber	(ACM)
Silicone rubber	(VMQ)
Fluorinated rubber	(FKM)
Hydrogenated Nitrile rubber	(HNBR)

A further development of the Nitrile rubber has led to the so called hydrogenated Nitrile rubber (HNBR). The heat and ozone resistance is significantly better. This material can replace Acrylic rubber and in certain cases also Fluorinated rubber. In order to satisfy the wide range of demands made on seals, a special composition has been developed for each type of rubber. Other compositions are also available to meet some extreme requirements.

Table IV Material recommendations

Materials for sealing common media		Material designation				
		Acrylonitrile Butadiene Rubber NBR	Fluorocarbon Rubber FKM	Polyacrylate Rubber ACM	Silicone Rubber VMQ	Hydrogenated Acrylonitrile Butadiene Rubber HNBR
		Material Abbreviation				
		N	V	A	S	H
		Max. permissible constant temperature (°C)				
Mineral fluids	Engine oils	100	170	125	150	130
	Transmission oils	80	150	125	130	110
	Hypoid transmission oils	80	150	125	--	110
	ATF oils	100	170	125	--	130
	Hydraulic fluids (DIN 51524)	90	150	120	--	130
	Greases	90	--	--	--	100
Flame retardant hydraulic fluids (VDMA 24317) (VDMA 24320)	Oil-water emulsion	70	--	--	60	70
	Water-oil emulsion	70	--	--	60	70
	Aqueous solutions	70	--	--	--	70
	Water-free fluids	--	150	--	--	--
Other media	Fuel oils	90	--	--	--	100
	Water	90	100	--	--	100
	Lyes	90	100	--	--	100
	Air	100	200	150	200	130

Due to the different configurations of the media, the above-mentioned temperature ranges are for guidance only. Depending on the medium, significant deviations may occur.



Description of rubber materials

Nitrile Rubber (NBR)

Advantages:

- Good oil resistance
- Good heat resistance up to 100°C in oil
- High tensile strength (special compounds over 20 MPa)
- High elongation at break
- Low swelling in water

Limitations:

- Poor weather and ozone resistance
- Poor resistance against polar fluids (ester, ether, ketones and aniline)
- Poor resistance against chlorinated hydrocarbons (carbon tetrachloride, trichlorethylene)
- Poor resistance against aromatic fluids (e.g. benzene, toluene)

Fluids, mineral oils and above all high-alloyed mineral oils (hypoid oils) containing larger quantities of aromatic hydrocarbons have a high swelling effect on NBR-compounds. The swelling behavior can be improved by increasing the acrylonitrile content.

However an inferior cold flexibility and resistance to compression set must be accepted. The additives in high-alloyed oils can in certain cases cause an additional interaction between the elastomer and the additive, thus influencing the elasticity.

Hydrogenated Nitrile Rubber (HNBR)

Advantages:

- Good oil resistance, also in hypoid oils
- Good heat resistance, up to + 150 °C
- Good mechanical properties
- Good weather and ozone resistance

Limitations:

- Poor resistance against polar fluids (esters, ethers, ketones and aniline)
- Poor resistance against chlorinated hydrocarbons (carbon tetrachloride, trichlorethylene)
- Poor resistance against aromatic fluids (bensene, toluene)

Polyacrylic Rubber (ACM)

Advantages:

- Good resistance against oils and fuels (better than Nitrile rubber)
- Heat resistance about 50 °C better than for Nitrile rubber, 150 °C in oil and 125 °C in air
- Good weather and ozone resistance

Limitations:

- Not usable in contact with water and water solutions, even smaller quantities of water in oil
- Limited cold flexibility to about -20 °C, somewhat poorer than normal NBR
- Limited tensile strength and tear resistance, especially above 100 °C
- Poor wear resistance (considerably inferior compared to NBR)
- Poor resistance against polar and aromatic fluids and chlorinated hydrocarbons



Fluorinated Rubber (FKM)

Advantages:

- The resistance against oils and fuels is better than for any other rubber type
- The only highly elastic rubber material, which is resistant to aromatic and chlorinated hydrocarbons
- Excellent heat resistance, the best one after silicone rubber, up to 200°C
- Excellent weather and ozone resistance
- Excellent acid resistance (only inorganic acids, not suitable for organic acids e.g. acetic acid)

Limitations:

- Limited cold flexibility, to approx. -20°C to -25°C
- Limited tensile and tear strength, especially above 100°C
- High compression set in hot water
- Poor resistance to polar solvents

Silicone Rubber (VMQ)

Advantages:

- Best heat resistance of all rubber types
- Best cold resistance of all rubber types
- Excellent weather and ozone resistance
- Resistant against aliphatic mineral oils and most grease types

Limitations:

- Poor tensile and tear strength for standard compounds
- Poor wear resistance
- Poor resistance against aromatic oils and oxidized mineral oils
- Poor diffusion resistance



Radial Oil Seal

Working parameters

Temperature resistance

Increasing temperature accelerates the aging of the rubber, the material becomes hard and brittle, the elongation decreases and the compression set increases. Axial cracks at the sealing edge are a typical indication that the seal has been exposed to excessively high temperature.

The aging of the rubber has appreciable significance on the useful life of the seal. The temperature limits for the principal materials are illustrated in Figure 8. They should only be regarded as approximate, since the materials are also affected by contact media. It can generally be said that a temperature increase of 10°C (in air) will halve the theoretical useful life of the rubber.

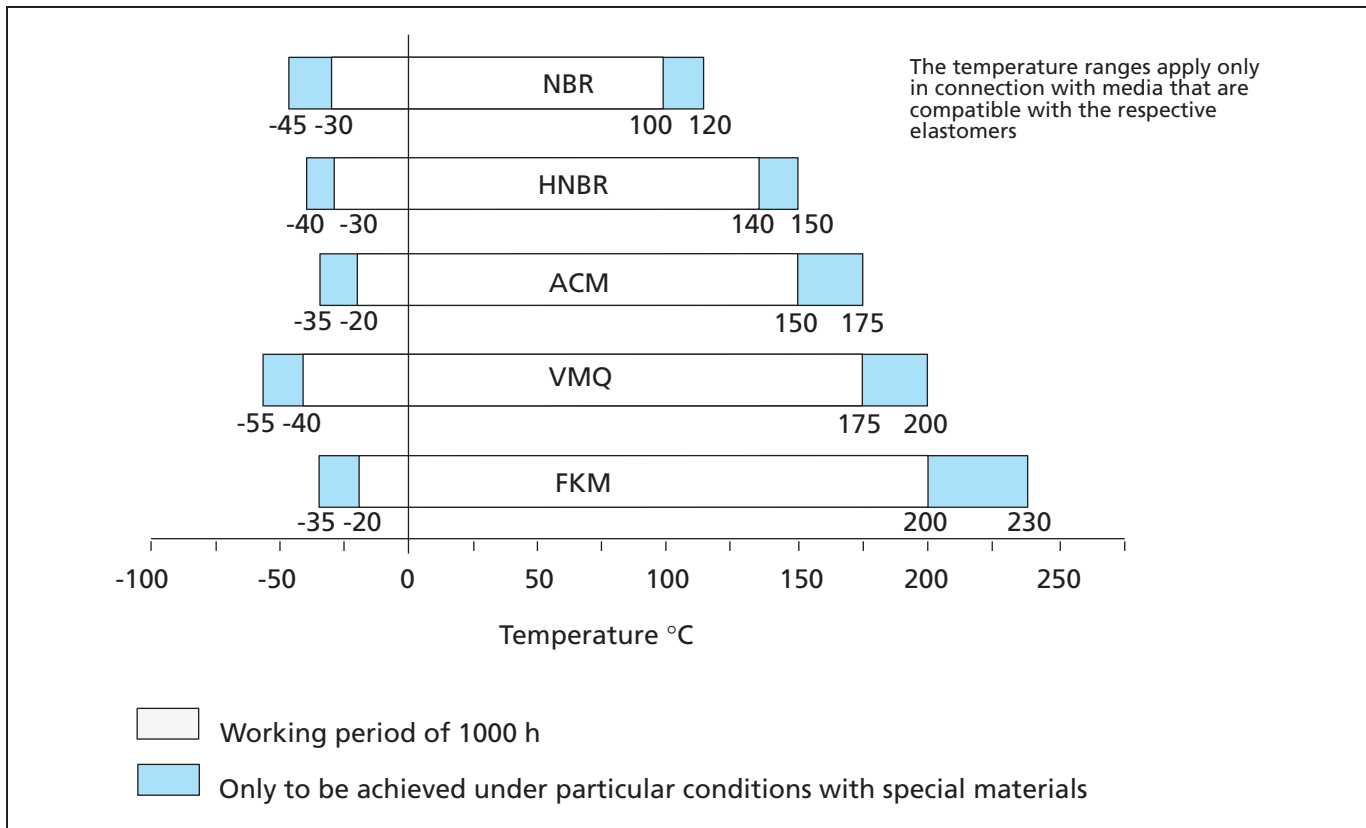

Figure 8 Temperature limits for some common types of rubber

Temperature

Temperature is the most critical criteria to be considered when selecting a rotary seal.

The temperature limits indicated in the selection tables are maximum operating temperatures of the sealing material in fluids to which the sealing material is compatible (good chemical resistance and controlled swelling/shrinkage).

The above descriptions show that the temperature in the sealing area is influenced by various parameters especially:

- The lubricating capability of the fluid and its ability to dissipate the heat generated under the sealing lip.
- The circumferential velocity
- The pressure applied

The resulting temperature in the sealing area must be considered to select the appropriate material. The initial temperature of the fluid can increase by up to 50% depending on operating parameters. For all applications please refer to the recommendations in the various chapters and contact your local Trelleborg Sealing Solutions marketing company.



Working parameters

Overpressure

When the sealing element is exposed to pressure it is forced against the shaft and the area of the lip in contact with the shaft increases. The friction as well as the generated heat, increases. As a result, when the seal is under pressure, the specified values of peripheral speed cannot be maintained but must be reduced in relation to the magnitude of the pressure. At high peripheral speeds even overpressures of 0.01 to 0.02 MPa may cause difficulties. By fitting a separate back-up ring the types (TRA, TRC, TRB) can be used for overpressure above 0.05 MPa. The separate back-up ring shape follows the rear profile of the sealing element but without mutual contact when no pressure differential exists. See Figure 9. However, the back-up ring requires accurate fitting.

Please ask your local Trelleborg Sealing Solutions marketing company for suitable back-up ring drawing. Seal type TRU is formed to support the sealing element. See Figure 9. The type TRP/6CC is designed with a short and sturdy sealing lip, which allows overpressures without using a separate back-up ring. When a back-up ring is installed or when the types TRU, TRP/6CC are used, overpressures of 0.4 to 0.5 MPa are permissible at moderate peripheral speeds.

At very high pressures, the seals with rubber-covered cases should be employed in order to avoid leakage between the periphery of the seal and the housing bore. When the seal is under pressure there is a risk of axial movement in the housing bore (pop-out). This effect can be prevented by locating the seal against a shoulder, with a spacer ring or a circlip.

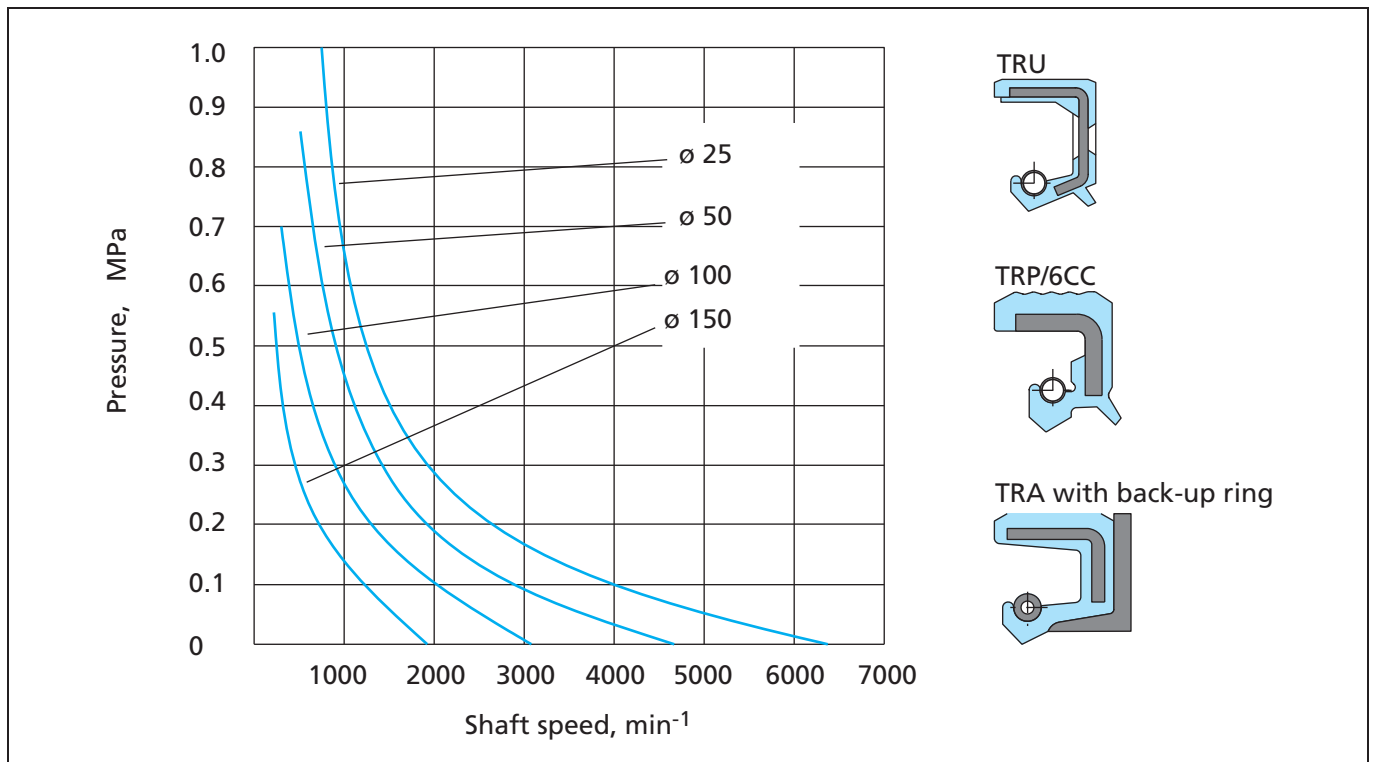

Figure 9 Permissible overpressure for supported lip seals and for pressure seals



Radial Oil Seal

Working parameters

Peripheral speed and number of revolutions

Different designs of the sealing element affect the magnitude of the friction and thus result in varying temperature rises. Various designs of the sealing element allow different maximum peripheral speeds. Figure 10 shows the approximate maximum values for the permissible peripheral speed for sealing elements (without dust lip), i.e. seal type TRC, TRA, TRB, etc, made with materials NBR, ACM, FKM and VMQ, with no

differential pressure, and where adequate lubrication or cooling of the sealing edge by the sealed medium exists. In addition the maximum permissible operating temperatures shown in table IV must not be exceeded. The curve shows that higher peripheral speeds are permissible for larger shaft diameters more than for the smaller. This is due to the fact that the cross-sectional area increases in proportion to the square of the diameter, thus increasing the heat dissipation capacity.

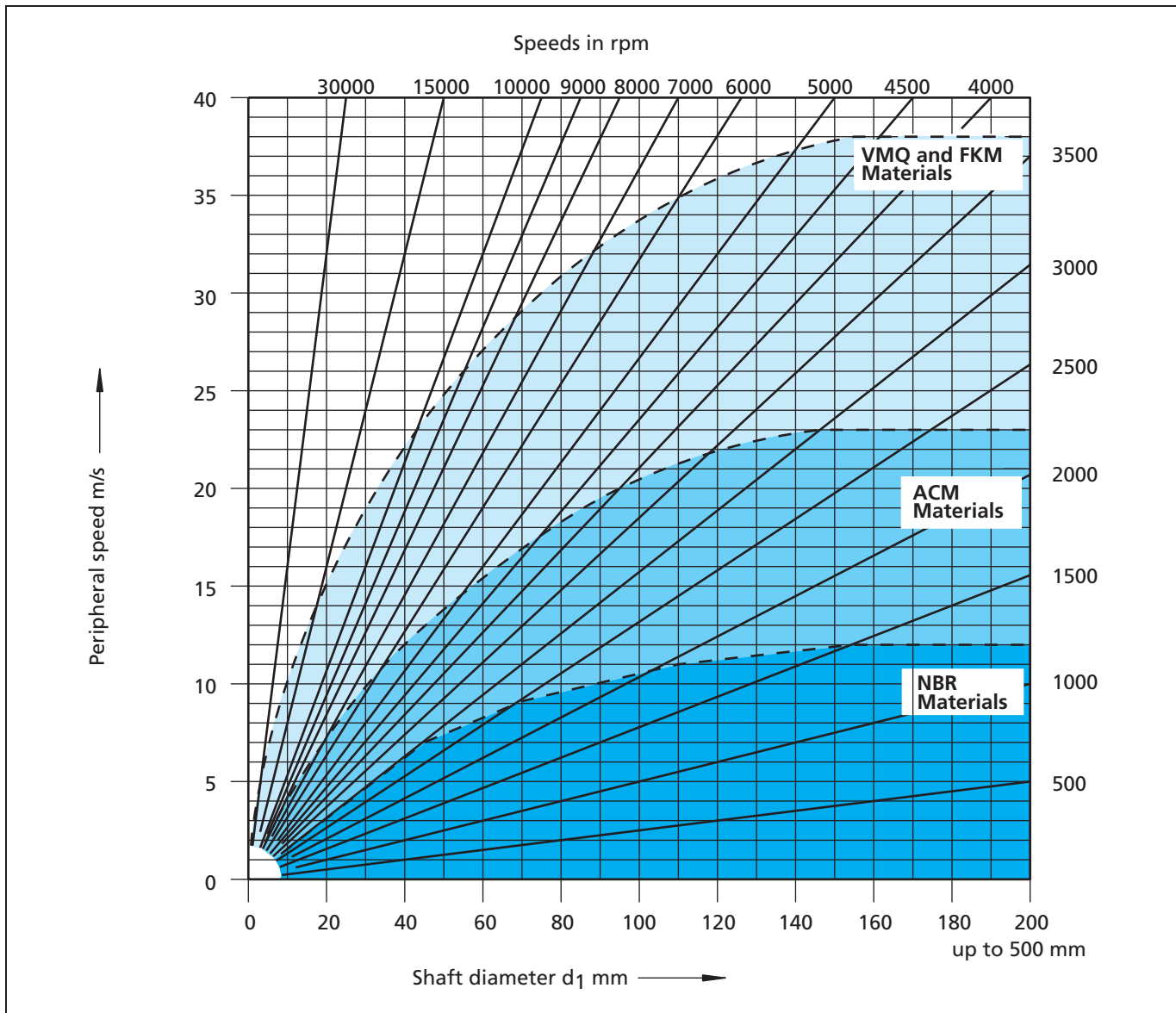

Figure 10 Permissible speeds in pressure-free state to DIN 3761



Working parameters

Frictional loss

The frictional loss is often of significant magnitude, particularly when low powers are transmitted. The frictional loss is affected by the following parameters: seal design and material, spring force, speed, temperature, medium, shaft design, and lubrication. Figure 11 shows the frictional losses in watts caused by a seal without dust lip when fitted in accordance with our technical instructions. In certain cases the frictional loss can be reduced by a special design of the sealing lip, reduction of the spring force or by employing a special grade of rubber. Our technical department will be pleased to provide advice on such matters. It should be noted that the frictional loss during the "running in" period is greater than shown in the figure. The normal "running in" period is a few hours.

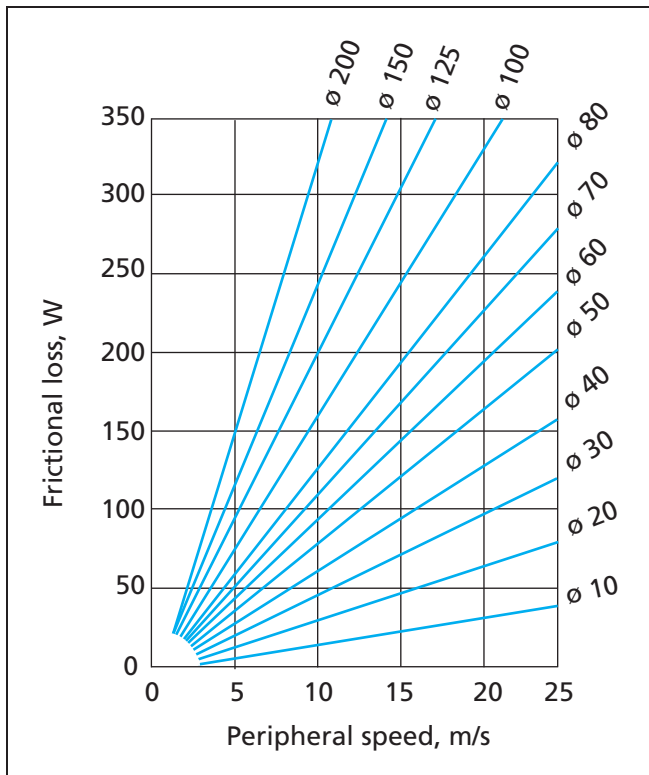

Figure 11 Frictional loss for TRA type seal of Nitrile rubber

Leakage control

When defining leakage control one must differentiate between static sealing (sealing of two surfaces without motion relative to one another) and dynamic sealing (relative motion between the two surfaces).

With a moving seal surface, a fluid film separates the sliding surfaces from one another; a dynamic seal gap forms. Unlike in static sealing, the leakage path is not fully closed off, so small quantities may escape. Seals in which a dynamic seal gap forms between the seal body and a rotating shaft cannot be tight in the physical sense.

Absolute tightness in the physical sense cannot be achieved with a seal gap alone when sealing moving parts.

For many technical applications, however, it is quite adequate if the "leakage" is reduced to such an extent that there are no negative consequences for the environment or the operation of the assembly. This is called technical tightness.

Technical tightness must be specified by the user or manufacturer of an assembly, i.e. in some circumstances maximum permitted leakage rates must be defined.

For example, leakage classes are defined for oil seals in DIN 3761 Part II (Motor vehicles).

The German standard DIN 3761 classifies the tightness of lip seals into leakage classes 1 to 3. A so called zero-leakage is also defined. Zero-leakage means a function related film of moisture at the sealing edge to a non-drip formation of medium over the back-face of the seal. It is better to accept this "minimum leakage" rather than risking the lip to be damaged due to insufficient lubrication. The permissible leakage in class 1 to 3 is max 1 g to 3 g per seal for a test time of 240 hours.



Radial Oil Seal

Working parameters

Media

The media to be sealed influences heavily the choice of the seal and material type. Mainly liquid media need to be sealed in rotary applications. Pasty media generally restrict the use of rotary seals, especially in terms of circumferential velocity. Gaseous media require specially adapted seal designs.

Liquid media:

Most of the applications relate to lubricating fluids but also hydraulic fluids based on mineral oils acc. DIN 51524 or ISO 6743 or fire resistant hydraulic fluids as well as environmentally friendly hydraulic fluids. In specific application aggressive media with low lubricating capabilities must be sealed. Sealing of other fluids such as water or FDA compliant fluids require in many cases a special sealing solution and will not be covered in detail in this catalogue. For specific needs please contact your local Trelleborg Sealing Solutions marketing company. The media is the first criteria to be considered for the selection of the sealing material type. It will also influence the seal family and the profile.

The evaluation of the compatibility of the seal material with the media to be sealed is based on the analysis of the values of tensile strength, elongation, volume change and hardness change resulting from an immersion test of testing slabs. Please contact your local Trelleborg Sealing Solutions marketing company to select the optimum material for your application.

Mineral oils:

Mainly used in transmissions, elastomer materials have good compatibility with mineral oils within the recommended temperature range. Some mineral oils e.g. hypoid transmission oils contain special additives which produce more demanding operating conditions e.g. temperature range and/or high pressure. For these fields testing is recommended.

Synthetic oils:

For improvement of the viscosity, high temperature and/or service life, new oils with specific additives have been launched as partial or full synthetic oils. Elastomer sealing materials give the same good compatibility to synthetic mineral oils as they do to mineral oils. However, compatibility needs to be checked. .

Grease:

Often used for roller and plain bearings, this media requires special adaptation of the sealing solution. To reduce the risk of tilting the sealing lip and allow the sealing lip to open under increasing pressure, the seal is installed in the reverse direction. Another important parameter to be considered is the maximum circumferential velocity. The maximum speed must be reduced to 50% of the permitted speed in oil, due to the poor heat exchange the grease can provide.

Above this limit the change from grease to oil or installation of seal with PTFE based lip (Turcon® and other) should be considered.

Poor lubricating media:

For those media an initial lubrication of the seal is required to avoid dry running. In such applications we recommend the radial oil seal with dust lip. The area between the lips will be used as a lubricant reservoir. Two seals in tandem Radial oil seal/ Radial oil seal or Radial oil seal/GAMMA seal will provide the same result

Aggressive media:

Generally aggressive media (e.g. solvents) have poor lubricating properties and therefore we recommend Turcon® Varilip® or PDR seals. Turcon® and other PTFE materials solve the problem of chemical resistance and the metal cage can be produced out of various Stainless Steel materials.





Environmentally-friendly hydraulic fluids (bio oils)

When machines or process equipment are hydraulically operated, escaping hydraulic oil can pollute surface waters and the ground. One way of minimizing the danger posed by unwanted leakage, is the use of biologically degradable, non toxic oils. In many countries, there are already statutory regulations and catalogs of requirements for dealing with materials that endanger water. Hydraulic and transmission fluids that protect the environment are already specified in some cases. Figure 12 shows the types of biodegradable fluids.

Environmentally-friendly fluids have application in all systems, which operate for example in mobile and agricultural machinery and in the water and forestry industries. In stationary systems, they are employed in plants where water is at risk, such as locks, water turbines and for foodstuffs and pharmaceutical products.

An important criterion for biologically rapidly degradable fluids is their compatibility with seals. In Table V the resistance of elastomeric materials are given to "bio-oils".

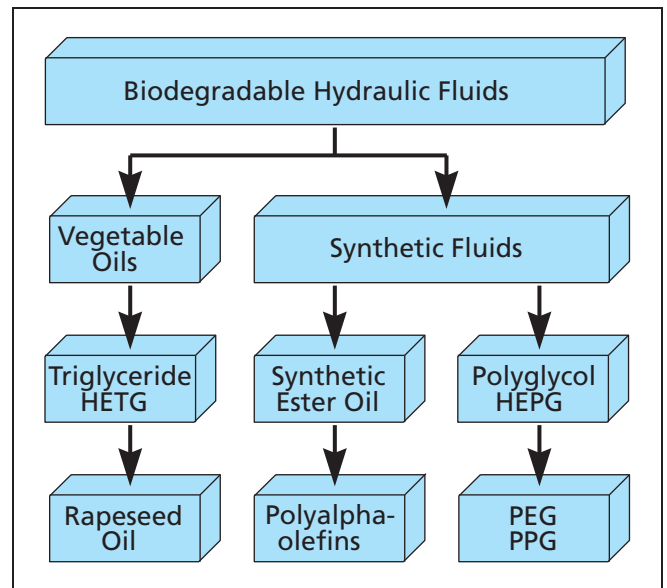

Figure 12 Biodegradable hydraulic fluids

Table V Recommendations for the use of standard elastomer materials and accordance with ISO VG 32 to 68 and VDMA Directive 24569

Oil Temperature	< 60°C	< 80°C	< 100°C	< 120°C
Oil Type / ISO VG	32 - 68	32 - 68	32 - 68	32 - 68
HETG (Rapeseed)	AU ¹	AU ¹	—	—
	NBR	NBR	—	—
	HNBR	HNBR	—	—
	FKM	FKM	—	—
HEES	AU ¹	AU ¹	—	—
	NBR ¹	NBR ¹	—	—
	HNBR ¹	HNBR ¹	—	—
	FKM ¹	FKM	FKM	FKM
HEPG (PAG)	AU ¹			
	NBR ¹	NBR		
	HNBR ¹	HNBR	HNBR	HNBR
	FKM ¹	FKM ²	FKM ²	FKM ²
HEPR (PAO)	not yet specified	not yet specified	not yet specified	not yet specified

1. For dynamic application, specific test required

2. Preferred peroxide cured FKM



Radial Oil Seal

Standard types of rotary seals

Standard elastomeric rotary shaft seals are designed according to DIN 3760 (3761) and ISO 6194/1 recommendations.

Types DIN A and DIN AS may have wavy or flat outer sheath.

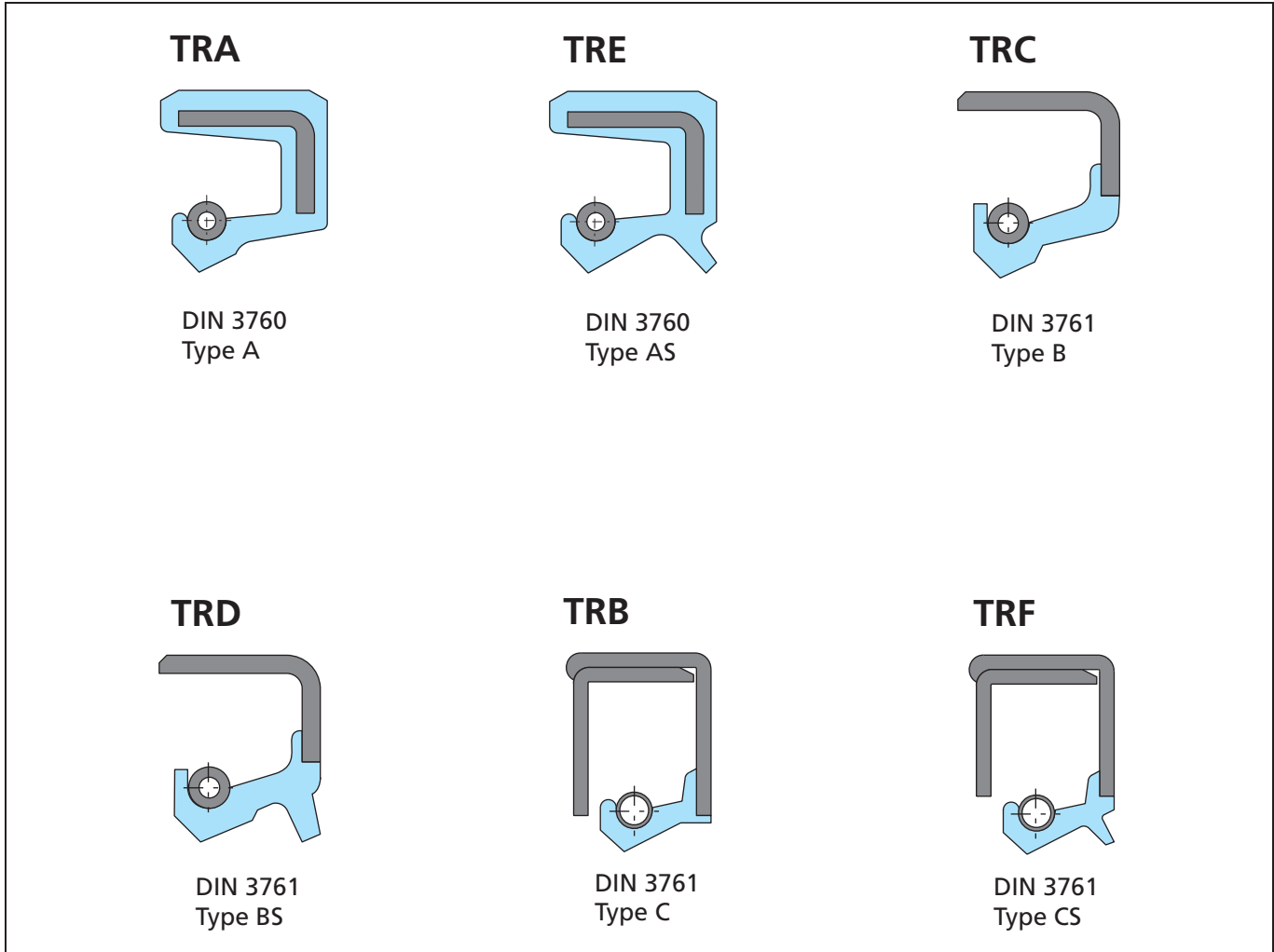

Figure 13 Standard types



■ Trelleborg Sealing Solutions type TRA

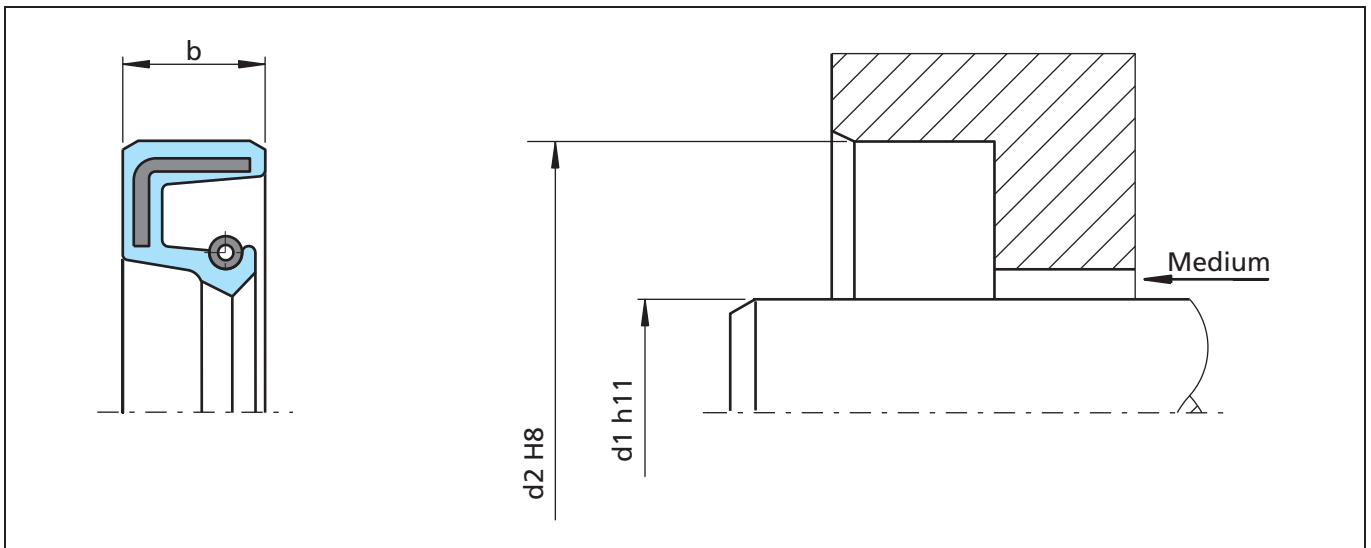

Figure 14 Installation drawing

General description

Trelleborg Sealing Solutions type TRA are seals with completely rubber covered outer diameter. Two different O.D design are available: Flat rubber sheath as well as wavy.

This type is not recommended for use in heavily polluted environments.

Advantages

- Good static sealing
- Compensation of different thermal expansion
- Reduced risk of fretting corrosion
- Higher bore surface roughness is allowed
- Installation in split-housings
- Modern lip design provides low radial forces

Application examples

- Transmission systems (e.g. gearboxes)
- Pumps
- Electrical motors
- Machine tools

Technical data

Pressure:	up to 0.05 MPa
Temperature:	-40°C to +200°C (depending on material)
Speed:	up to 30m/s (depending on material)
Media:	mineral and synthetic lubricants (CLP, HLP, APGL etc.)

Trelleborg Sealing Solutions has carried out several thousands compatibility tests. Please ask for details.

Important Note:

The above data are maximum values and cannot be used at the same time, e. g. the maximum operating speed depends on material type, pressure and temperature.



Radial Oil Seal

Table VI Materials

Standard material*	TSS material code	Standard metal insert**	Standard spring**
NBR (70 Shore A)	N7MM	Carbon steel	Carbon steel
NBR (75 Shore A)	4N011		
FKM (70 Shore A)	VCBV	Carbon steel	Stainless steel
FKM (75 Shore A)	4V012		

* Special grades and other materials (ACM, EACM, EPDM, HNBR, VMQ) on request.

** Metal insert, and spring as well, can be supplied in different materials on request.

Ordering example oil seal TSS type

TSS Type: A
 Code: TRA
 Dimensions: Shaft diameter 25 mm
 Housing diameter 40 mm
 Width 7 mm
 Material: NBR
 Material Code: N7MM

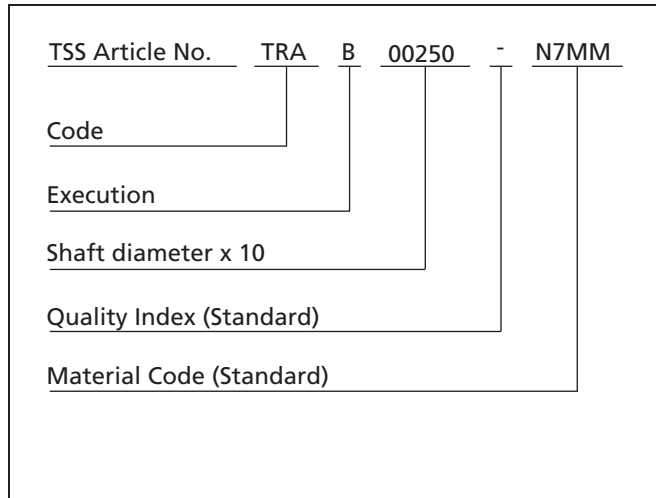

Table VII Preferred series / Dimension, TSS part numbers

Dimension			TSS Part No.	TSS	
d ₁	d ₂	b		NBR	FKM
4	11	5	TRA200040		X
4	12	6	TRA100040	X	X
5	15	6	TRA000050	X	X
6	12	5.5	TRA400060	X	X
6	15	4	TRA000060	X	
6	16	5	TRA100060	X	
6	16	7	TRAA00060	X	X
6	19	7	TRA300060	X	X
6	22	7	TRAB00060	X	X
6	22	8	TRA600060	X	
7	16	7	TRA000070	X	X
7	22	7	TRAA00070	X	X
8	14	4	TRA700080	X	
8	16	5	TRA100080	X	
8	16	7	TRA200080	X	X

The dimensions printed in **bold** type correspond to the recommendations in DIN 3760, draft September 1996.

Radial Oil Seal



Dimension			TSS Part No.	TSS	
d ₁	d ₂	b		NBR	FKM
8	18	5	TRA300080	X	
8	22	4	TRA500080	X	
8	22	7	TRAA00080	X	X
8	22	8	TRAF00080		X
8	24	7	TRAB00080	X	X
8.5	18	7	TRA000085	X	
9	22	7	TRAA00090	X	X
9	24	7	TRAB00090	X	
9	26	7	TRAC00090	X	
9	30	7	TRA300090	X	
10	16	4	TRA000100	X	X
10	18	4	TRA200100	X	
10	18	6	TRA300100	X	
10	19	7	TRA400100	X	X
10	22	7	TRAA00100	X	X
10	24	7	TRAB00100	X	
10	25	8	TRA500100	X	
10	26	7	TRAC00100	X	X
10	28	7	TRA600100	X	
11	17	4	TRA000110	X	X
11	19	7	TRA100110	X	
11	22	7	TRAA00110	X	
11	26	7	TRAB00110	X	
11	30	7	TRA200110	X	
11.5	22	5	TRA000115		X
12	19	5	TRA000120	X	X
12	20	4	TRA100120	X	
12	20	5	TRA200120	X	
12	22	4	TRAF00120	X	X
12	22	7	TRAA00120	X	X
12	24	7	TRAB00120	X	X
12	25	5	TRA600120	X	
12	25	8	TRA700120	X	X
12	26	7	TRA800120	X	
12	26	8	TRAJ00120	X	
12	28	7	TRAC00120	X	X

The dimensions printed in **bold** type correspond to the recommendations in DIN 3760, draft September 1996.



Radial Oil Seal

Dimension			TSS Part No.	TSS	
d ₁	d ₂	b		NBR	FKM
12	30	7	TRAD00120	X	X
12	30	10	TRA300120	X	
12	32	7	TRAH00120	X	X
12	32	10	TRAI00120	X	
12	37	10	TRAK00120	X	
12	45	7	TRAL00120	X	
13	25	5	TRA100130	X	
13	26	7	TRA200130	X	X
13	30	8	TRA300130	X	
14	22	4	TRA000140	X	X
14	22	7	TRA400140	X	X
14	24	7	TRAA00140	X	X
14	25	5	TRA100140	X	
14	28	7	TRAB00140	X	
14	28.55	6.3	TRAF00140		X
14	30	7	TRAC00140	X	X
14	35	7	TRAD00140	X	
14.5	28.55	6.3	TRA000145		X
15	22	7	TRA000150	X	
15	24	5	TRAF00150	X	
15	24	7	TRA200150	X	X
15	25	5	TRA300150	X	X
15	26	6	TRA400150	X	
15	26	7	TRAA00150	X	X
15	28	5	TRA500150		X
15	28	7	TRA600150	X	X
15	30	7	TRAB00150	X	X
15	30	10	TRA700150	X	X
15	32	7	TRAC00150	X	X
15	35	7	TRAD00150	X	X
15	35	10	TRAJ00150	X	X
15	40	7	TRAN00150	X	
15	40	10	TRA100150	X	
15	42	7	TRAG00150	X	
15	42	10	TRAH00150	X	X
16	22	4	TRA000160	X	

The dimensions printed in **bold** type correspond to the recommendations in DIN 3760, draft September 1996.

Radial Oil Seal



Dimension			TSS Part No.	TSS	
d ₁	d ₂	b		NBR	FKM
16	24	4	TRA500160	X	
16	24	5	TRA200160	X	X
16	24	7	TRA300160	X	
16	26	7	TRA400160	X	
16	28	7	TRAA00160	X	X
16	30	7	TRAB00160	X	X
16	30	10	TRAF00160	X	X
16	32	7	TRAC00160	X	
16	35	7	TRAD00160	X	
16	35	10	TRA600160	X	X
17	25	4	TRA100170	X	
17	26	6	TRA300170	X	
17	28	5	TRA400170	X	X
17	28	6	TRA900170	X	
17	28	7	TRAA00170	X	X
17	30	7	TRAB00170	X	
17	32	7	TRAC00170	X	X
17	32	10	TRAP00170		X
17	35	5	TRAL00170	X	
17	35	7	TRAD00170	X	X
17	35	8	TRA700170	X	
17	40	7	TRAE00170	X	X
17	40	10	TRAF00170	X	
17	47	7	TRAG00170	X	X
17	47	10	TRAH00170	X	
18	24	4	TRA500180		X
18	28	7	TRA100180	X	X
18	30	7	TRAA00180	X	X
18	32	7	TRAB00180	X	X
18	32	8	TRA200180	X	X
18	35	7	TRAC00180	X	X
18	35	10	TRA300180	X	
18	40	7	TRAD00180	X	X
18	40	10	TRA400180	X	
19	32	7	TRA200190	X	
19	35	7	TRA300190	X	

The dimensions printed in **bold** type correspond to the recommendations in DIN 3760, draft September 1996.



Radial Oil Seal

Dimension			TSS Part No.	TSS	
d ₁	d ₂	b		NBR	FKM
19	35	10	TRA500190	X	X
19	40	10	TRA900190	X	
20	28	6	TRA100200	X	X
20	28	7	TRA300200	X	
20	30	5	TRA200200	X	X
20	30	7	TRAA00200	X	X
20	30	8	TRAJ00200		X
20	32	7	TRAB00200	X	X
20	35	5	TRA500200	X	
20	35	6	TRA600200	X	
20	35	6.2	TRAR00200	X	
20	35	7	TRAC00200	X	X
20	35	10	TRA800200	X	X
20	37	7	TRAM00200	X	
20	37	8	TRA900200	X	
20	38	7	TRAP00200	X	
20	40	7	TRAD00200	X	X
20	40	10	TRAF00200	X	
20	42	7	TRAG00200	X	X
20	42	10	TRAH00200	X	
20	47	6	TRAS00200		X
20	47	7	TRAE00200	X	X
20	47	9.5	TRAT00200		X
20	47	10	TRAI00200	X	
20	52	7	TRA400200	X	
20	52	10	TRAK00200	X	
22	30	7	TRAK00220		X
22	32	4	TRAE00220	X	
22	32	7	TRAA00220	X	X
22	35	5	TRA200220	X	
22	35	6	TRAF00220	X	
22	35	7	TRAB00220	X	X
22	35	8	TRA000220	X	
22	35	10	TRA100220	X	X
22	37	7	TRA300220	X	
22	38	7	TRAI00220	X	

The dimensions printed in **bold** type correspond to the recommendations in DIN 3760, draft September 1996.

Radial Oil Seal



Dimension			TSS Part No.	TSS	
d ₁	d ₂	b		NBR	FKM
22	38	8	TRA500220	X	
22	40	7	TRAC00220	X	X
22	40	10	TRA700220	X	
22	42	7	TRA800220	X	
22	42	10	TRA900220	X	
22	45	7	TRAH00220	X	
22	47	7	TRAD00220	X	X
22	47	10	TRAG00220	X	
22.5	53	10	TRA000225	X	X
23	40	10	TRA100230	X	
23	42	5	TRA500230	X	X
23	42	10	TRA200230	X	
24	35	7	TRAA00240	X	X
24	37	7	TRAB00240	X	
24	40	7	TRAC00240	X	X
24	42	8	TRA900240	X	
24	42	10	TRA600240	X	
24	47	7	TRAD00240	X	X
24	47	10	TRA300240	X	
25	32	6	TRA000250	X	
25	33	6	TRA300250	X	X
25	35	5	TRA400250	X	
25	35	7	TRAA00250	X	X
25	36	6	TRA500250	X	
25	37	5	TRAW00250	X	
25	37	7	TRA700250	X	X
25	38	7	TRA800250	X	X
25	40	5	TRA900250	X	
25	40	7	TRAB00250	X	X
25	40	8	TRAF00250	X	
25	40	10	TRAG00250	X	X
25	42	6	TRAMGA001	X	
25	42	7	TRAC00250	X	X
25	42	10	TRAH00250	X	X
25	43	10	TRAU00250		X
25	45	7	TRAI00250	X	X

The dimensions printed in **bold** type correspond to the recommendations in DIN 3760, draft September 1996.



Radial Oil Seal

Dimension			TSS Part No.	TSS	
d ₁	d ₂	b		NBR	FKM
25	45	10	TRAJ00250	X	X
25	46	7	TRAX00250	X	
25	47	7	TRAD00250	X	X
25	47	8	TRAK00250	X	X
25	47	10	TRAL00250	X	X
25	50	10	TRAM00250	X	X
25	52	7	TRAE00250	X	X
25	52	8	TRAN00250	X	
25	52	10	TRAO00250	X	
25	62	7	TRAQ00250	X	
25	62	8	TRA200250	X	
25	62	10	TRAR00250	X	X
26	34	4	TRA100260		X
26	37	7	TRAA00260	X	X
26	42	7	TRAB00260	X	
26	47	7	TRAC00260	X	
26	47	10	TRA300260		X
27	37	7	TRA300270	X	X
27	42	10	TRA600270	X	X
27	47	10	TRA800270	X	
27	50	8	TRA100270	X	
28	38	7	TRA000280	X	X
28	40	7	TRAA00280	X	X
28	42	7	TRA400280	X	
28	42	8	TRA200280	X	
28	42	10	TRA800280	X	X
28	42.5	8	TRAJ00280	X	X
28	43	10	TRA900280	X	X
28	45	8	TRAI00280	X	X
28	47	7	TRAB00280	X	X
28	47	10	TRA500280	X	
28	48	10	TRAG00280	X	
28	50	10	TRA600280		X
28	52	7	TRAC00280	X	X
28	52	10	TRA700280	X	
29	50	10	TRA300290	X	X

The dimensions printed in **bold** type correspond to the recommendations in DIN 3760, draft September 1996.

Radial Oil Seal



Dimension			TSS Part No.	TSS	
d₁	d₂	b		NBR	FKM
30	40	7	TRAA00300	X	X
30	40	8	TRAY00300	X	
30	40	10	TRAMGA002	X	
30	41	8	TRAMGA003	X	
30	42	5	TRAMGA004	X	
30	42	5.7	TRAV00300	X	
30	42	7	TRAB00300	X	X
30	44	10	TRA000300	X	
30	45	7	TRA400300	X	X
30	45	8	TRA500300	X	
30	45	10	TRA700300	X	
30	47	4	TRA800300	X	
30	47	7	TRAC00300	X	X
30	47	8	TRA900300	X	
30	47	10	TRAF00300	X	
30	48	8	TRAG00300	X	X
30	50	7	TRAI00300	X	
30	50	8	TRAH00300	X	
30	50	10	TRAJ00300	X	X
30	52	7	TRAD00300	X	X
30	52	8	TRAMGA005	X	
30	52	8.5	TRAMGA006	X	
30	52	10	TRAM00300	X	X
30	55	7	TRAN00300	X	X
30	55	10	TRAO00300	X	X
30	56	10	TRAMGA007	X	X
30	60	10	TRAQ00300	X	
30	62	7	TRAE00300	X	X
30	62	10	TRAR00300	X	X
30	62	12	TRAS00300	X	
30	72	8	TRAT00300	X	
30	72	10	TRAU00300	X	X
31	42	8	TRA200310	X	X
31	47	7	TRA000310	X	
32	40	7	TRAG00320	X	X
32	40	8	TRA000320	X	

The dimensions printed in **bold** type correspond to the recommendations in DIN 3760, draft September 1996.



Radial Oil Seal

Dimension			TSS Part No.	TSS	
d ₁	d ₂	b		NBR	FKM
32	42	7	TRA300320	X	X
32	45	7	TRAA00320	X	X
32	47	7	TRAB00320	X	X
32	50	8	TRA400320	X	X
32	50	10	TRA600320	X	X
32	52	6	TRAJ00320	X	
32	52	7	TRAC00320	X	X
32	52	10	TRA800320	X	X
32	54	8	TRA900320		X
32	55	10	TRA700320	X	
32	56	10	TRAH00320	X	
32	62	10	TRAI00320	X	
33	45	7	TRA000330	X	
34	50	10	TRA200340	X	X
34	52	8	TRA300340	X	X
34	52	10	TRA100340	X	
34	62	10	TRA600340	X	
35	45	7	TRA000350	X	X
35	47	4.5	TRAT00350	X	
35	47	7	TRAA00350	X	X
35	47	10	TRAMGA008	X	
35	48	9	TRAMGA009	X	
35	50	7	TRAB00350	X	X
35	50	8	TRA200350	X	
35	50	10	TRA300350	X	X
35	52	7	TRAC00350	X	X
35	52	8	TRA400350	X	
35	52	8.5	TRAMGA010	X	
35	52	10	TRA500350	X	X
35	54	10	TRAV00350	X	
35	55	8	TRA600350	X	X
35	55	10	TRA700350	X	X
35	56	10	TRA900350	X	X
35	58	10	TRAG00350	X	
35	60	10	TRAH00350	X	X
35	62	7	TRAD00350	X	X

The dimensions printed in **bold** type correspond to the recommendations in DIN 3760, draft September 1996.

Radial Oil Seal



Dimension			TSS Part No.	TSS	
d ₁	d ₂	b		NBR	FKM
35	62	8	TRAI00350	X	
35	62	10	TRAJ00350	X	
35	62	12	TRAK00350	X	
35	65	10	TRAL00350	X	
35	68	10	TRAW00350	X	X
35	68	12	TRAU00350	X	
35	72	7	TRAM00350	X	
35	72	10	TRAN00350	X	X
35	72	12	TRAO00350	X	
35	80	10	TRAQ00350	X	
35	80	13	TRAS00350	X	
36	47	7	TRAA00360	X	
36	50	7	TRAB00360	X	X
36	52	7	TRAC00360	X	X
36	56	10	TRA200360	X	
36	58	12	TRA500360	X	
36	62	7	TRAD00360	X	
36	68	10	TRA400360	X	
37	47.5	5	TRA500370		X
37	52	8	TRA600370	X	
37	52	10	TRA700370	X	
37	80	12	TRA400370	X	
38	50	7	TRA000380	X	
38	52	7	TRAA00380	X	X
38	52	8	TRAF00380	X	
38	52	10	TRAL00380	X	
38	54	6.5	TRA900380	X	X
38	54	10	TRA200380	X	
38	55	7	TRAB00380	X	X
38	55	10	TRA300380	X	
38	56	10	TRAG00380	X	
38	60	10	TRAJ00380	X	
38	62	7	TRAC00380	X	X
38	62	10	TRA500380	X	X
38	65	8	TRAI00380	X	
38	68	8	TRAM00380		X

The dimensions printed in **bold** type correspond to the recommendations in DIN 3760, draft September 1996.



Radial Oil Seal

Dimension			TSS Part No.	TSS	
d ₁	d ₂	b		NBR	FKM
38	70	10	TRAN00380	X	
38	72	10	TRA700380	X	
40	50	8	TRA000400	X	X
40	52	6	TRA100400	X	
40	52	7	TRAA00400	X	X
40	52	8	TRA200400	X	
40	52	10	TRA300400	X	
40	55	7	TRAB00400	X	X
40	55	8	TRA400400	X	
40	55	10	TRA500400	X	
40	56	8	TRA700400	X	
40	56	10	TRAL00400	X	
40	58	8	TRAMGA011	X	
40	58	9	TRA900400	X	
40	58	10	TRAF00400	X	X
40	58	12	TRAMGA012	X	
40	60	10	TRAH00400	X	X
40	62	7	TRAC00400	X	X
40	62	10	TRAI00400	X	X
40	62	11.5	TRAMGA013	X	
40	62	12	TRAJ00400	X	
40	65	10	TRAK00400	X	X
40	68	7	TRAM00400	X	
40	68	10	TRAN00400	X	X
40	68	12	TRAMGA014	X	
40	72	7	TRAD00400	X	X
40	72	10	TRAQ00400	X	X
40	80	7	TRAS00400	X	
40	80	8	TRAMGA015	X	
40	80	10	TRAT00400	X	X
40	85	10	TRAU00400	X	
40	90	8	TRAV00400	X	
40	90	12	TRAW00400	X	
42	55	7	TRA000420	X	
42	55	8	TRAA00420	X	X
42	56	7	TRA100420	X	X

The dimensions printed in **bold** type correspond to the recommendations in DIN 3760, draft September 1996.

Radial Oil Seal



Dimension			TSS Part No.	TSS	
d ₁	d ₂	b		NBR	FKM
42	58	10	TRA900420	X	
42	60	10	TRA200420	X	
42	62	7	TRA300420	X	X
42	62	8	TRAB00420	X	X
42	62	10	TRA400420	X	
42	65	10	TRA500420	X	
42	68	10	TRAI00420	X	
42	72	7	TRA700420	X	X
42	72	8	TRAC00420	X	X
42	72	10	TRA800420	X	
42	80	10	TRAH00420	X	
44	60	10	TRA000440	X	
44	62	10	TRA100440	X	
44	65	10	TRA200440	X	
44	70	12	TRA500440	X	
44	72	10	TRA600440	X	X
44.5	62	10	TRA000445	X	
45	52	7	TRA000450	X	
45	55	7	TRA200450	X	
45	58	7	TRA300450	X	
45	60	7	TRA400450	X	X
45	60	8	TRAA00450	X	X
45	60	10	TRA500450	X	X
45	62	7	TRA600450	X	X
45	62	8	TRAB00450	X	X
45	62	10	TRA800450	X	X
45	62	12	TRA900450	X	
45	65	8	TRAC00450	X	X
45	65	10	TRAF00450	X	
45	68	10	TRAH00450	X	
45	68	12	TRAI00450	X	
45	70	10	TRAJ00450	X	
45	72	7	TRAU00450	X	
45	72	8	TRAD00450	X	X
45	72	10	TRAK00450	X	
45	75	7	TRAL00450	X	

The dimensions printed in **bold** type correspond to the recommendations in DIN 3760, draft September 1996.



Radial Oil Seal

Dimension			TSS Part No.	TSS	
d ₁	d ₂	b		NBR	FKM
45	75	8	TRAM00450	X	
45	75	10	TRAN00450	X	X
45	80	8	TRAO00450	X	
45	80	10	TRAP00450	X	X
45	85	10	TRAR00450	X	X
47	62	6	TRA000470	X	
48	62	8	TRAA00480	X	X
48	62	10	TRA500480	X	
48	65	10	TRA000480	X	
48	68	10	TRA100480	X	X
48	72	8	TRAB00480	X	X
48	72	10	TRA400480	X	X
48	80	10	TRA600480	X	
48	90	10	TRA900480	X	X
50	60	10	TRAM00500	X	
50	62	7	TRA000500	X	X
50	62	10	TRA100500	X	
50	65	8	TRAA00500	X	X
50	65	10	TRA200500	X	X
50	68	8	TRAB00500	X	X
50	68	10	TRA300500	X	X
50	70	8	TRA500500	X	
50	70	10	TRA600500	X	X
50	70	12	TRA700500	X	X
50	72	6	TRA800500	X	
50	72	8	TRAC00500	X	X
50	72	10	TRA900500	X	X
50	74	10	TRAP00500	X	
50	75	10	TRAG00500	X	X
50	80	8	TRAD00500	X	X
50	80	10	TRAH00500	X	X
50	80	13	TRAQ00500	X	
50	85	10	TRAI00500	X	
50	90	10	TRAK00500	X	X
50	100	10	TRAN00500	X	
51	72	10	TRA000510	X	

The dimensions printed in **bold** type correspond to the recommendations in DIN 3760, draft September 1996.

Radial Oil Seal



Dimension			TSS Part No.	TSS	
d ₁	d ₂	b		NBR	FKM
52	65	8	TRA800520	X	
52	68	8	TRAA00520	X	X
52	68	10	TRA000520	X	
52	69	10	TRA500520	X	
52	72	8	TRAB00520	X	X
52	72	10	TRA100520	X	
52	75	12	TRA300520	X	X
52	76.2	10	TRA900520	X	
52	80	10	TRA400520	X	
52	85	10	TRA700520	X	
53	68	10	TRA000530	X	
54	70	10	TRA000540	X	
54	85	10	TRA500540	X	
54	90	13	TRA200540	X	
55	68	8	TRA000550	X	X
55	68	10	TRAM00550	X	
55	70	8	TRAA00550	X	X
55	70	10	TRA100550	X	
55	72	8	TRAB00550	X	X
55	72	10	TRA200550	X	X
55	75	8	TRA300550	X	
55	75	10	TRA400550	X	X
55	75	12	TRAN00550	X	
55	78	10	TRAI00550	X	
55	80	7	TRAL00550	X	X
55	80	8	TRAC00550	X	X
55	80	10	TRA600550	X	X
55	80	12	TRA700550	X	
55	80	13	TRA800550	X	
55	85	8	TRAD00550	X	X
55	85	10	TRA900550	X	X
55	90	10	TRAG00550	X	X
55	100	10	TRAH00550	X	X
55	100	12	TRAK00550	X	
56	70	8	TRAA00560	X	
56	72	8	TRAB00560	X	

The dimensions printed in **bold** type correspond to the recommendations in DIN 3760, draft September 1996.



Radial Oil Seal

Dimension			TSS Part No.	TSS	
d ₁	d ₂	b		NBR	FKM
56	72	9	TRA000560	X	
56	80	8	TRAC00560	X	
56	85	8	TRAD00560	X	
58	72	8	TRAA00580	X	X
58	80	8	TRAB00580	X	X
58	80	10	TRA200580	X	X
58	85	10	TRA300580	X	
58	90	10	TRA100580	X	
60	70	7	TRA000600	X	
60	72	8	TRA100600	X	X
60	75	8	TRAA00600	X	X
60	78	10	TRA300600	X	X
60	80	8	TRAB00600	X	X
60	80	10	TRA500600	X	X
60	80	13	TRA600600	X	
60	85	8	TRAC00600	X	X
60	85	10	TRA800600	X	X
60	85	13	TRA900600	X	
60	90	8	TRAD00600	X	
60	90	10	TRAF00600	X	X
60	90	13	TRAG00600	X	
60	95	10	TRAH00600	X	X
60	100	10	TRAI00600	X	
60	110	12	TRAN00600	X	
60	110	13	TRAJ00600		X
62	75	10	TRA000620	X	
62	80	9	TRA100620	X	
62	80	10	TRA200620	X	X
62	85	10	TRAA00620	X	X
62	90	10	TRAB00620	X	X
62	95	10	TRA300620	X	
62	100	12	TRA500620	X	
63	85	10	TRAA00630	X	
63	90	10	TRAB00630	X	
63.5	90	13	TRA000635	X	
64	77	8	TRA400640		X

The dimensions printed in **bold** type correspond to the recommendations in DIN 3760, draft September 1996.

Radial Oil Seal



Dimension			TSS Part No.	TSS	
d ₁	d ₂	b		NBR	FKM
64	80	8	TRA000640	X	X
64	85	10	TRA300640	X	
65	80	8	TRA000650	X	X
65	80	10	TRA100650	X	
65	85	8	TRA200650	X	
65	85	10	TRAA00650	X	X
65	85	12	TRA300650	X	
65	90	10	TRAB00650	X	X
65	90	12	TRA400650	X	
65	90	13	TRA500650	X	
65	95	10	TRA600650	X	
65	100	10	TRAC00650	X	X
65	100	12	TRA800650	X	
65	110	10	TRA900650	X	
65	120	10	TRAF00650	X	
65	120	12	TRA700650	X	
68	85	10	TRA000680	X	
68	90	10	TRAA00680	X	X
68	100	10	TRAB00680	X	X
70	85	7	TRA000700	X	
70	85	8	TRA100700	X	X
70	90	10	TRAA00700	X	X
70	90	13	TRA300700	X	X
70	95	10	TRA400700	X	
70	95	13	TRA500700	X	X
70	100	10	TRAB00700	X	X
70	100	12	TRA600700	X	
70	105	13	TRAN00700	X	
70	110	8	TRA900700	X	
70	110	12	TRAG00700	X	X
72	90	10	TRA000720	X	
72	95	10	TRAA00720	X	X
72	100	10	TRAB00720	X	X
75	90	8	TRA000750	X	X
75	90	10	TRA100750	X	
75	95	10	TRAA00750	X	X

The dimensions printed in **bold** type correspond to the recommendations in DIN 3760, draft September 1996.



Radial Oil Seal

Dimension			TSS Part No.	TSS	
d ₁	d ₂	b		NBR	FKM
75	95	12	TRA200750	X	X
75	100	10	TRAB00750	X	X
75	100	12	TRA400750	X	X
75	105	12	TRAH00750	X	
75	105	13	TRAI00750	X	X
75	110	10	TRA600750	X	
75	110	12	TRA700750	X	X
75	115	10	TRA500750	X	
78	100	10	TRAA00780	X	X
78	110	12	TRA000780		X
80	95	8	TRA000800	X	X
80	100	10	TRAA00800	X	X
80	100	12	TRAF00800	X	
80	100	13	TRA100800	X	
80	105	10	TRA200800	X	X
80	105	13	TRA300800	X	
80	110	10	TRAB00800	X	X
80	110	12	TRA400800	X	X
80	110	13	TRA500800	X	X
80	115	10	TRA600800	X	
80	115	13	TRAK00800	X	
80	120	13	TRA900800	X	X
80	125	13	TRA800800	X	
80	140	13	TRAJ00800	X	
80	150.5	13	TRAL00800	X	X
82	105	12	TRA100820	X	
82	110	12	TRA200820	X	
85	100	9	TRA300850	X	X
85	105	10	TRA000850	X	
85	105	13	TRA900850	X	X
85	110	10	TRA100850	X	X
85	110	12	TRAA00850	X	X
85	110	13	TRA200850	X	X
85	115	13	TRA400850	X	
85	120	12	TRAB00850	X	X
85	130	12	TRAI00850	X	

The dimensions printed in **bold** type correspond to the recommendations in DIN 3760, draft September 1996.

Radial Oil Seal



Dimension			TSS Part No.	TSS	
d ₁	d ₂	b		NBR	FKM
85	130	13	TRA800850	X	
88	110	12	TRA000880	X	X
90	110	8	TRA100900	X	
90	110	10	TRA200900	X	X
90	110	12	TRAA00900	X	X
90	110	13	TRA300900	X	
90	115	12	TRAF00900		X
90	115	13	TRA500900	X	
90	120	10	TRA600900	X	
90	120	12	TRAB00900	X	X
90	120	13	TRA700900	X	
90	130	12	TRA000900	X	
90	140	13	TRA900900	X	
92	120	13	TRA000920	X	X
95	110	6	TRA000950		X
95	110	10	TRA800950	X	X
95	110	12	TRA500950	X	X
95	115	12	TRA600950	X	X
95	115	13	TRA100950	X	
95	120	12	TRAA00950	X	X
95	120	13	TRA200950	X	
95	125	12	TRAB00950	X	X
95	130	12	TRA400950	X	
95	136	13	TRA900950	X	X
95	145	13	TRA700950	X	
95	150.5	13	TRAF00950	X	
95	180.5	13	TRAG00950	X	X
96	117	10	TRA000960		X
98	120	13	TRA000980	X	X
100	115	9	TRAG01000	X	
100	120	10	TRA001000	X	
100	120	12	TRAA01000	X	X
100	120	13	TRA101000	X	
100	125	12	TRAB01000	X	X
100	125	13	TRA201000	X	
100	130	10	TRA301000	X	

The dimensions printed in **bold** type correspond to the recommendations in DIN 3760, draft September 1996.



Radial Oil Seal

Dimension			TSS Part No.	TSS	
d ₁	d ₂	b		NBR	FKM
100	130	12	TRAC01000	X	X
100	130	13	TRA701000	X	
100	140	13	TRA50100	X	
100	150	12	TRA601000	X	
100	185	13	TRAI01000	X	
102	130	13	TRA001020	X	X
105	125	10	TRA001050	X	
105	125	13	TRA101050	X	
105	130	12	TRAA01050	X	X
105	130	13	TRA301050	X	
105	140	12	TRAB01050	X	X
105	150	15	TRA401050		X
110	130	8	TRA101100	X	
110	130	12	TRAA01100	X	X
110	130	13	TRA201100	X	
110	140	12	TRAB01100	X	X
110	140	13	TRA401100	X	
110	150	13	TRA801100	X	
110	150	15	TRA601100	X	
110	180.5	13	TRA301100	X	
110	200	13	TRA701100	X	
115	130	12	TRA001150		X
115	135	10	TRA101150	X	
115	140	12	TRAA01150	X	X
115	140	13	TRA201150	X	
115	150	10	TRA301150		X
115	150	12	TRAB01150	X	X
120	140	12	TRA101200	X	
120	140	13	TRA201200	X	X
120	145	15	TRAF01200	X	
120	150	12	TRAA01200	X	X
120	150	13	TRA401200	X	
120	160	12	TRAB01200	X	X
122	150	15	TRA001220	X	X
125	150	12	TRAA01250	X	X
125	150	13	TRA001250	X	

The dimensions printed in **bold** type correspond to the recommendations in DIN 3760, draft September 1996.

Radial Oil Seal



Dimension			TSS Part No.	TSS	
d ₁	d ₂	b		NBR	FKM
125	160	12	TRAB01250	X	X
128	150	15	TRA001280	X	
130	150	10	TRA001300	X	X
130	150	10.8	TRA6001300	X	
130	160	7.5	TRA5011300	X	
130	160	12	TRAA01300	X	X
130	160	13	TRA101300	X	
130	160	15	TRA301300	X	
130	170	12	TRAB01300	X	X
130	170	13	TRA201300		X
130	180	15	TRA401300	X	
135	160	12	TRA001350	X	X
135	160	13	TRA101350	X	
135	160	15	TRA301350	X	
135	170	12	TRAA01350	X	X
140	160	12	TRA201400	X	
140	160	13	TRA001400	X	X
140	165	12	TRA101400	X	X
140	170	12	TRA301400	X	X
140	170	13	TRA401400	X	
140	170	15	TRAA01400	X	X
140	180	12	TRA801400	X	X
140	190	15	TRA901400	X	
145	170	15	TRA401450	X	
145	175	15	TRAA01450	X	X
145	180	12	TRA301450	X	
148	170	15	TRA001480	X	X
150	170	15	TRA101500		X
150	180	12	TRA201500	X	X
150	180	13	TRA301500	X	
150	180	15	TRAA01500	X	X
155	174	12	TRA001550	X	
155	180	15	TRA101550	X	
155	190	15	TRA201550	X	
160	180	10	TRA501600	X	
160	180	15	TRA001600	X	

The dimensions printed in **bold** type correspond to the recommendations in DIN 3760, draft September 1996.



Radial Oil Seal

Dimension			TSS Part No.	TSS	
d ₁	d ₂	b		NBR	FKM
160	185	10	TRA101600	X	
160	185	13	TRA601600		X
160	190	13	TRA201600	X	
160	190	15	TRAA01600	X	X
160	200	12	TRA401600	X	X
165	190	13	TRA001650	X	X
170	190	10	TRA301700	X	
170	200	12	TRA201700	X	X
170	200	15	TRAA01700	X	X
175	200	10	TRA001750		X
175	200	15	TRA101750	X	X
175	205	15	TRAR01750	X	X
180	200	15	TRA001800	X	
180	210	15	TRAA01800	X	X
180	215	16	TRA101800	X	
180	220	15	TRA201800	X	
185	210	10	TRA001850		X
185	210	13	TRA101850	X	X
190	215	15	TRA601900		X
190	220	15	TRAA01900	X	X
190	225	16	TRA101900	X	
195	230	16	TRA001950	X	
200	225	15	TRA202000	X	
200	230	15	TRAA02000	X	X
200	250	15	TRA002000	X	
205	230	16	TRA102050		X
210	240	15	TRAA02100	X	X
210	250	15	TRA002100	X	
215	240	12	TRA002150	X	
220	250	15	TRAA02200	X	X
220	260	16	TRA102200	X	
230	260	15	TRAA02300	X	X
230	270	15	TRA002300	X	
240	270	15	TRAA02400	X	X
240	280	15	TRA002400	X	
240	335	15	TRA202400	X	

The dimensions printed in **bold** type correspond to the recommendations in DIN 3760, draft September 1996.

Radial Oil Seal



Dimension			TSS Part No.	TSS	
d ₁	d ₂	b		NBR	FKM
250	280	15	TRAA02500	X	X
250	290	15	TRA002500	X	
260	290	15	TRA102600	X	
260	300	20	TRAA02600	X	X
265	290	16	TRA002650	X	X
265	310	16	TRA102650	X	
280	310	15	TRA202800		X
280	320	20	TRAA02800	X	
300	340	16	TRA003000	X	
300	340	18	TRA103000	X	
300	340	20	TRAA03000	X	
320	360	20	TRAA03200	X	
340	380	20	TRAA03400	X	
360	400	18	TRA003600		X
360	400	20	TRAA03600	X	
380	420	20	TRAA03800	X	X
400	440	20	TRAA04000	X	
420	450	15	TRA004200	X	
420	460	20	TRAA04200	X	
440	480	20	TRAA04400	X	X
480	520	20	TRAA04800	X	
500	540	20	TRAA05000	X	
800	840	20	TRA008000	X	

The dimensions printed in **bold** type correspond to the recommendations in DIN 3760, draft September 1996.



Radial Oil Seal

■ Trelleborg Sealing Solutions type TRE

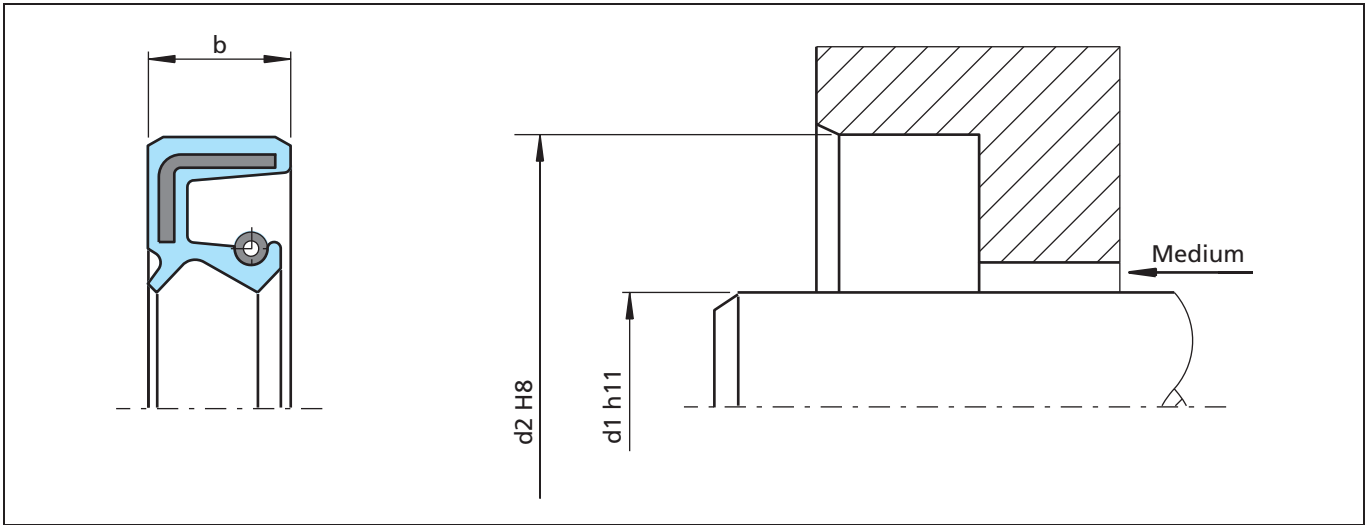

Figure 15 Installation drawing

General description

Trelleborg Sealing Solutions type TRE are seals with completely rubber covered outer diameter. Two different O.D. design are available: Flat rubber sheath as well as wavy. The additional dust lip protects the main sealing lip against dust and other fine solid contaminants and therefore this type is recommended for use in polluted environments. To achieve a long lifetime a suitable lubricant between the two sealing lips should be applied.

Advantages

- Good static sealing
- Compensation of different thermal expansion
- Reduced risk of fretting corrosion
- Effective protection against air side contaminants
- Higher bore surface roughness is allowed
- Installation in split-housings
- Modern lip design provides low radial forces

Application examples

- Transmission systems (e.g. gearboxes)
- Pumps
- Electrical motors
- Machine tools

Technical data

Pressure:	up to 0.05 MPa
Temperature:	-40°C to +200°C (depending on material)
Speed:	up to 30 m/s (depending on material)
Media:	mineral and synthetic lubricants (CLP, HLP, APGL etc.)

Trelleborg Sealing Solutions has carried out several thousands compatibility tests. Please ask for details.

Important Note:

The above data are maximum values and cannot be used at the same time, e. g. the maximum operating speed depends on material type, pressure and temperature.



Table VIII Materials

Standard material*	TSS material code	Standard metal insert**	Standard spring**
NBR (70 Shore A)	N7MM	Carbon steel	Carbon steel
NBR (75 Shore A)	4N011		
FKM (70 Shore A)	VCBV	Carbon steel	Stainless steel
FKM (75 Shore A)	4V012		

* Special grades and other materials (ACM, EACM, EPDM, HNBR, VMQ) on request.

** Metal insert, and spring as well, can be supplied in different materials on request.

Ordering example oil seal TSS type

TSS type: E
 Code: TRE
 Dimensions: Shaft diameter 15 mm
 Housing diameter 30 mm
 Width 7 mm
 Material: NBR
 Material Code: N7MM

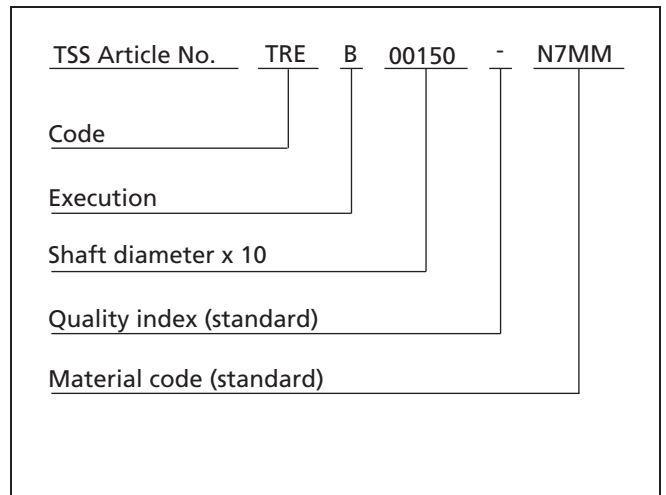

Table IX Preferred series / Dimension, TSS part numbers

Dimension			TSS Part No.	TSS	
d ₁	d ₂	b		NBR	FKM
8	16	7	TRE000080	X	
10	18	6	TRE100100	X	
10	19	7	TRE200100	X	
10	20	5	TRE300100	X	
10	22	7	TREA00100	X	X
10	26	7	TREC00100	X	
11	17	4	TRE000110	X	
12	19	5	TRE000120	X	
12	20	5	TRE400120	X	
12	22	6	TRE200120	X	
12	22	7	TREA00120	X	X
12	25	7	TREE00120	X	
12	28	7	TREC00120	X	X
12	32	7	TRE300120	X	
13	26	9	TRE100130		X

The dimensions printed in **bold** type correspond to the recommendations in DIN 3760, draft September 1996.



Radial Oil Seal

Dimension			TSS Part No.	TSS	
d ₁	d ₂	b		NBR	FKM
14	35	7	TRED00140		X
15	24	7	TRE000150	X	X
15	26	7	TREA00150	X	X
15	28	7	TRE100150	X	
15	30	7	TREB00150	X	X
15	32	7	TREC00150	X	X
15	35	7	TRED00150	X	X
16	28	7	TREA00160	X	X
16	29	4	TRE400160	X	
17	28	7	TREA00170	X	
17	30	7	TREB00170	X	
17	37	7	TRE400170		
17	40	7	TREE00170	X	
17.8	26.2	3.5	TRE000178		X
18	28	7	TRE000180	X	
18	30	7	TREA00180	X	
18	32	7	TREB00180	X	
18	35	7	TREC00180	X	
20	30	7	TREA00200	X	X
20	34	7	TRE100200	X	
20	35	7	TREC00200	X	X
20	36	7	TRE200200	X	
20	40	7	TRED00200	X	X
20	42	7	TRE300200	X	X
20	42	10	TREJ00200	X	
20	47	7	TREE00200	X	X
20	47	10	TREH00200	X	
20	52	8	TREG00200	X	X
22	28	4	TRE700220	X	
22	32	7	TREA00220	X	X
22	35	7	TREB00220	X	
22	40	7	TREC00220	X	X
22	47	7	TRED00220	X	
24	32	7	TRE000240	X	
24	36	7	TRE100240	X	X
24	47	7	TRED00240	X	

The dimensions printed in **bold** type correspond to the recommendations in DIN 3760, draft September 1996.

Radial Oil Seal



Dimension			TSS Part No.	TSS	
d ₁	d ₂	b		NBR	FKM
25	32	6	TREER00250		X
25	35	6	TRE000250	X	
25	35	7	TREA00250	X	X
25	38	8	TREK00250	X	
25	40	7	TREB00250	X	
25	40	8	TRE100250	X	
25	42	7	TREC00250	X	
25	42	10	TRE300250	X	X
25	47	7	TRED00250	X	X
25	47	8	TRE600250	X	
25	47	10	TRE700250	X	
25	52	7	TREE00250	X	X
25	52	10	TRE900250	X	
25	62	7	TREG00250	X	X
26	37	7	TREA00260	X	
28	40	7	TREA00280	X	X
28	42	8	TRE200280	X	
28	45	7	TREE00280		X
28	47	7	TREB00280	X	X
28	47	10	TRE400280	X	X
28	52	7	TREC00280	X	X
28	52	10	TRE500280	X	
30	40	7	TREA00300	X	X
30	42	5.7	TREQ00300	X	
30	42	6	TRE000300	X	
30	42	7	TREB00300	X	X
30	42	8	TRE100300	X	
30	47	7	TREC00300	X	X
30	47	8	TREK00300	X	X
30	48	7	TREL00300	X	
30	50	10	TRE600300	X	
30	52	7	TRED00300	X	
30	52	10	TRE700300	X	X
30	55	7	TRE800300	X	X
30	55	10	TRE900300	X	X
30	62	7	TREE00300	X	X

The dimensions printed in **bold** type correspond to the recommendations in DIN 3760, draft September 1996.



Radial Oil Seal

Dimension			TSS Part No.	TSS	
d ₁	d ₂	b		NBR	FKM
30	62	10	TREF00300	X	
30	72	10	TREG00300	X	
32	42	5	TRE300320	X	
32	45	7	TREA00320	X	
32	45	8	TRE600320	X	
32	47	10	TRE400320	X	
32	50	10	TRE100320	X	
32	52	7	TREC00320	X	X
33	50	6	TRE000330	X	
34	72	10	TRE100340		X
35	47	7	TREA00350	X	X
35	50	7	TREB00350	X	
35	52	6	TRE100350	X	
35	52	7	TREC00350	X	X
35	52	8	TREF00350	X	
35	52	10	TRE200350	X	X
35	55	8	TREK00350	X	
35	56	10	TRE300350	X	
35	58	10	TREG00350	X	
35	62	7	TRED00350	X	
35	62	8	TREU00350	X	
35	62	10	TRE400350	X	X
35	62	12	TRE500350	X	X
35	72	7	TREH00350	X	
35	72	10	TRE700350	X	
35	72	12	TRE800350	X	X
35	80	10	TRE900350	X	
35	80	12	TREQ00350	X	
36	47	7	TREA00360	X	
36	50	7	TREB00360	X	
36	52	7	TREC00360		X
36	54	7	TRE100360	X	
36	58	10	TRE400360	X	
36	68	10	TRE000360	X	
38	52	7	TREA00380	X	X
38	62	10	TRE500380		X

The dimensions printed in **bold** type correspond to the recommendations in DIN 3760, draft September 1996.

Radial Oil Seal



Dimension			TSS Part No.	TSS	
d ₁	d ₂	b		NBR	FKM
40	52	5	TREO00400	X	
40	52	7	TREA00400	X	X
40	55	7	TREB00400	X	
40	55	8	TRE100400	X	X
40	56	8	TREG00400	X	
40	58	9	TREQ00400	X	
40	58	10	TREI00400	X	
40	60	10	TRE400400	X	X
40	62	7	TREC00400	X	X
40	62	9	TREZ00400	X	
40	62	10	TRE600400	X	X
40	68	7	TRE700400	X	
40	68	8	TREY00400	X	
40	72	7	TRED00400	X	X
40	72	10	TRE800400	X	X
40	80	7	TRE900400	X	
40	80	8	TREMGE001	X	
40	80	10	TREF00400	X	X
40	80	12	TREMGE002	X	
40	90	8	TREL00400	X	
40	90	10	TREN00400	X	
42	55	8	TREA00420	X	
42	60	7	TRE700420	X	
42	62	7	TRE300420	X	
42	62	10	TRE800420		X
42	72	8	TREC00420	X	
42	72	10	TRE600420		X
45	60	7	TRE000450	X	
45	60	8	TREA00450	X	X
45	62	7	TRE100450	X	
45	62	8	TREB00450	X	X
45	62	10	TRE200450	X	
45	65	8	TREC00450	X	X
45	65	10	TRE300450	X	
45	68	8	TRE400450	X	
45	68	10	TRE500450	X	

The dimensions printed in **bold** type correspond to the recommendations in DIN 3760, draft September 1996.



Radial Oil Seal

Dimension			TSS Part No.	TSS	
d ₁	d ₂	b		NBR	FKM
45	72	8	TRED00450	X	
45	72	10	TRE600450	X	
45	72	12	TRE700450	X	
45	75	7	TRE800450	X	
45	75	8	TREI00450	X	X
45	75	10	TRE900450	X	X
45	80	10	TREF00450	X	
45	85	10	TREG00450	X	X
45	90	10	TREH00450	X	
47	90	10	TRE0P0470		
48	62	8	TREA00480	X	X
48	65	10	TRE000480		X
48	68	10	TRE100480	X	X
48	72	7	TRE200480	X	
48	72	8	TREB00480		X
48	72	12	TRE300480	X	
48	72.5	10	TRE500480	X	
50	62	7	TRE200500	X	
50	65	8	TREA00500	X	X
50	65	10	TREIP0500	X	
50	68	7	TREK00500	X	
50	68	8	TREB00500	X	X
50	68	10	TRE000500	X	
50	70	10	TRE100500	X	
50	72	7	TREF00500	X	X
50	72	8	TREC00500	X	X
50	72	10	TRE300500	X	
50	72	12	TRE400500	X	
50	75	10	TRE500500	X	
50	80	8	TRED00500	X	X
50	80	10	TRE600500	X	X
50	90	8	TRE800500	X	
50	90	10	TRE900500	X	X
52	68	8	TREA00520	X	X
52	72	8	TREB00520	X	X
52	72	10	TRE000520	X	

The dimensions printed in **bold** type correspond to the recommendations in DIN 3760, draft September 1996.

Radial Oil Seal



Dimension			TSS Part No.	TSS	
d ₁	d ₂	b		NBR	FKM
52	85	10	TRE400520		X
52	100	10	TRE5P0520	X	
54	72	10	TRE000540	X	
54	72.5	9	TRE100540	X	
55	68	8	TRE000550	X	X
55	70	8	TREA00550	X	X
55	70	10	TREH00550	X	
55	72	8	TREB00550	X	X
55	72	10	TRE200550	X	X
55	75	8	TRE300550	X	X
55	75	10	TRE400550	X	X
55	80	8	TREC00550	X	
55	80	10	TRE600550	X	X
55	85	10	TRE700550	X	
55	90	8	TREG00550	X	
55	90	10	TRE800550	X	X
55	100	10	TRE900550	X	
55	110	10	TREJ00550	X	X
56	72	7	TRE200560	X	
56	72	8	TREB00560		X
58	80	8	TREB00580	X	
58	80	10	TRE000580	X	X
60	75	8	TREA00600	X	X
60	75	10	TREH00600	X	
60	80	7	TRE800600	X	
60	80	8	TREB00600	X	X
60	80	10	TRE100600	X	X
60	82	9	TRE200600	X	
60	85	8	TREC00600	X	
60	85	10	TRE300600	X	
60	85	12	TREI00600	X	
60	90	8	TRED00600	X	
60	90	10	TRE400600	X	
60	95	10	TRE500600	X	
60	110	8	TRE900600	X	
60	110	12	TREGP0600	X	

The dimensions printed in **bold** type correspond to the recommendations in DIN 3760, draft September 1996.



Radial Oil Seal

Dimension			TSS Part No.	TSS	
d ₁	d ₂	b		NBR	FKM
62	90	12	TRE3P0620	X	
62	110	10	TRE100620	X	
62	120	12	TRE2P0620	X	
63	80	9	TRE000630	X	
65	80	8	TRE000650	X	
65	85	10	TREA00650	X	X
65	85	12	TRE200650	X	X
65	85	13	TRE300650	X	X
65	90	10	TREB00650	X	X
65	95	10	TRE700650	X	
65	100	10	TREC00650	X	
65	100	12	TRE5P0650	X	
65	120	10	TRE600650	X	
65	120	12	TRE9P0650	X	
68	87	8	TRE200680	X	
68	90	10	TREA00680	X	X
68	94	9	TRE300680	X	
68	110	13	TRE100680	X	
70	85	8	TRE000700	X	
70	90	10	TREA00700	X	X
70	90	12	TRE100700	X	
70	95	13	TRE200700	X	
70	100	10	TREB00700	X	X
70	110	8	TRE700700	X	
70	110	12	TREFP0700	X	
70	110	13	TRE400700	X	
70	120	10	TRE500700	X	
70	125	12	TRE600700	X	
72	86	7	TRE100720	X	
72	95	12	TREAP0720	X	
72	140	12	TRE3P0700	X	
75	90	10	TREC00750	X	
75	95	8	TRE000750	X	X
75	95	9	TRE600750	X	
75	95	10	TREA00750	X	X
75	95	12	TREF00750	X	

The dimensions printed in **bold** type correspond to the recommendations in DIN 3760, draft September 1996.

Radial Oil Seal



Dimension			TSS Part No.	TSS	
d ₁	d ₂	b		NBR	FKM
75	100	10	TREB00750	X	X
75	100	12	TRE100750	X	
75	100	13	TRE200750	X	
75	110	13	TRE500750	X	
75	115	10	TRE800750	X	
75	115	12	TRE900750	X	
75	120	12	TRE300750	X	
79	120	13	TRE000790	X	
80	100	7	TRE000800	X	
80	100	10	TREA00800	X	X
80	100	12	TRE500800	X	
80	105	13	TRE200800	X	
80	110	10	TREB00800	X	X
80	115	10	TRE300800	X	
80	120	13	TRE400800	X	
80	140	13	TRE900800	X	
80	140	15	TRE600800	X	
85	100	13	TRE900850	X	
85	105	10	TRE100850	X	
85	105	12	TRE800850		X
85	110	12	TREA00850	X	X
85	120	10	TRE300850	X	
85	120	12	TREB00850		X
85	130	10	TRE400850	X	
85	130	12	TRE700850	X	X
85	130	13	TRE500850		X
85	140	12	TREG00850	X	
85	150	12	TRE600850	X	
90	110	8	TRE600900		X
90	110	12	TREA00900	X	X
90	110	13	TRE000900	X	X
90	120	12	TREB00900	X	
90	120	13	TRE200900	X	
90	140	12	TRE400900	X	
95	115	7	TRE800950	X	
95	115	12	TRE000950	X	

The dimensions printed in **bold** type correspond to the recommendations in DIN 3760, draft September 1996.



Radial Oil Seal

Dimension			TSS Part No.	TSS	
d ₁	d ₂	b		NBR	FKM
95	115	13	TRE100950	X	X
95	120	12	TREA00950	X	
95	120	13	TRE200950	X	
95	125	12	TREB00950	X	X
95	130	13	TRE300950	X	
100	120	10	TRE001000	X	
100	120	12	TREA01000	X	X
100	125	12	TREB01000	X	
100	125	13	TRE101000	X	
100	130	12	TREC01000	X	X
100	130	13	TRE201000	X	
100	150	12	TRE501000	X	
100	160	14	TRE301000	X	
100	180	12	TRE401000	X	
105	120	7	TRE001050	X	
105	125	13	TRE101050	X	
105	130	12	TREA01050	X	
105	140	12	TREB01050	X	
105	140	13	TRE401050		
110	130	12	TREA01100	X	
110	140	12	TREB01100	X	X
110	140	13	TRE401100	X	
110	140	15	TRE501100	X	
110	170	14	TRE301100	X	
115	140	12	TREA01150	X	X
115	140	15	TRE301150		
118	150	12	TRE001180	X	
120	140	13	TRE001200	X	
120	142	12	TRE501200	X	
120	150	12	TREA01200	X	X
120	150	15	TRE201200	X	X
120	160	12	TREB01200	X	
120	200	14	TRE301200	X	
125	150	12	TREA01250	X	
125	155	14	TRE301250	X	
125	160	15	TRE401250	X	

The dimensions printed in **bold** type correspond to the recommendations in DIN 3760, draft September 1996.

Radial Oil Seal



Dimension			TSS Part No.	TSS	
d ₁	d ₂	b		NBR	FKM
130	160	7.5	TRE401300	X	
130	160	12	TREA01300	X	
130	160	15	TRE001300	X	
130	230	14	TRE201300	X	
135	160	15	TRE001350	X	
135	165	13	TRE201350	X	
135	170	12	TREA01350	X	X
140	160	13	TRE001400	X	
140	170	14	TRE401400		X
140	170	15	TREA01400	X	X
140	210	15	TRE301400	X	
145	175	15	TREA01450	X	X
148	170	14	TRE001480	X	
150	180	13	TRE001500	X	
150	180	15	TREA01500	X	X
155	180	15	TRE001550	X	
160	190	15	TREA01600	X	X
160	200	15	TRE001600	X	
165	190	8	TRE101650	X	
165	190	13	TRE201650	X	
170	200	7.5	TRE301700	X	
170	200	15	TREA01700	X	X
180	200	13	TRE101800	X	
180	210	15	TREA01800	X	X
180	215	15	TRE201800	X	
190	220	12	TRE001900	X	
190	220	15	TREA01900	X	X
200	230	15	TREA02000	X	X
210	240	15	TREA02100	X	
220	250	15	TREA02200	X	
230	260	15	TREA02300	X	
240	270	15	TREA02400	X	X
250	280	15	TREA02500	X	
260	280	16	TRE002600	X	
260	300	20	TREA02600	X	
280	320	20	TREA02800	X	

The dimensions printed in **bold** type correspond to the recommendations in DIN 3760, draft September 1996.



Radial Oil Seal

Dimension			TSS Part No.	TSS	
d ₁	d ₂	b		NBR	FKM
300	340	18	TRE003000	X	
300	340	20	TREA03000	X	
320	360	20	TREA03200	X	
350	380	16	TRE003500	X	
360	400	20	TREA03600		X
394	420	16	TRE003940	X	
420	470	20	TRE004200	X	
440	480	20	TREA04400	X	

The dimensions printed in **bold** type correspond to the recommendations in DIN 3760, draft September 1996.



■ Trelleborg Sealing Solutions type TRC

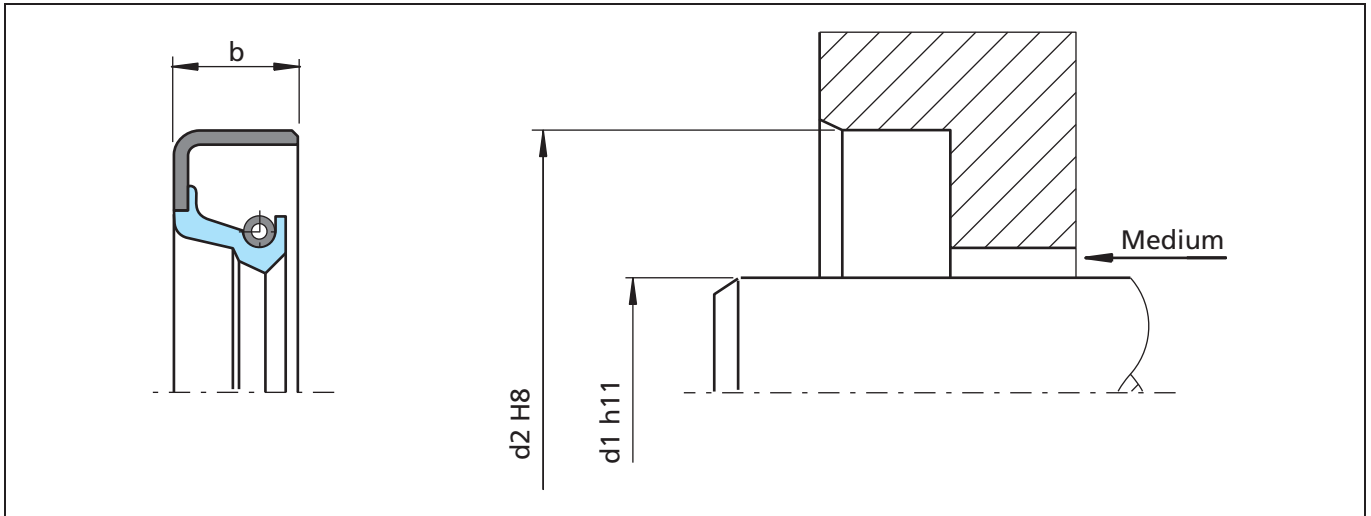

Figure 16 Installation drawing

General description

Trelleborg Sealing Solutions type TRC are metal cased radial lip seals. This type is not recommended for use in heavily polluted environments. As the static sealing between housing and metallic shell is limited, low viscosity media can "creep". Better performance can be achieved with Epoxy-based resin O.D. coating. This special treatment is on request.

Advantages

- Good radial stiffness, especially for large diameters
- Good fitting stability avoiding pop-out of the seal
- Modern lip design provides low radial forces
- Cost effective
- Suitable for use in combination with axial seal (V-Ring and GAMMA-seal)

Application examples

- Transmission systems (e.g. gearboxes)
- Pumps
- Electrical motors
- Machine tools
- Heavy engineering applications

Technical data

Pressure:	up to 0.05 MPa
Temperature:	-40°C to +200°C (depending on material)
Speed:	up to 30 m/s (depending on material)
Media:	mineral and synthetic lubricants (CLP, HLP, APGL etc.)

Trelleborg Sealing Solutions has carried out several thousands compatibility tests. Please ask for details.

Important Note:

The above data are maximum values and cannot be used at the same time, e. g. the maximum operating speed depends on material type, pressure and temperature.



Radial Oil Seal

Table X Materials

Standard material*	TSS material code	Standard metal insert**	Standard spring**
NBR (70 Shore A)	N7MM	Carbon steel	Carbon steel
NBR (75 Shore A)	4N011		
FKM (70 Shore A)	VCBV	Carbon steel	Stainless steel
FKM (75 Shore A)	4V012		

* Special grades and other materials (ACM, EACM, EPDM, HNBR, VMQ) on request.

** Metal insert, and spring as well, can be supplied in different materials on request.

Ordering example oil seal TSS type

TSS type: C
 Code: TRC
 Dimensions: Shaft diameter 20 mm
 Housing diameter 35 mm
 Width 7 mm
 Material: NBR
 Material Code: N7MM

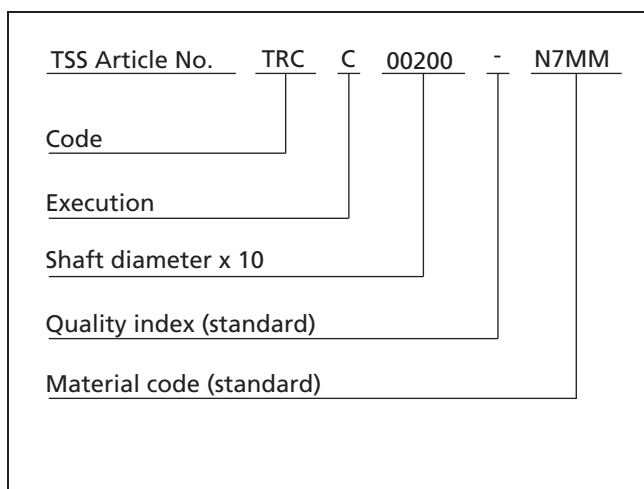

Table XI Preferred series / Dimension, TSS part numbers

Dimension			TSS Part No.	TSS	
d ₁	d ₂	b		NBR	FKM
8	16	7	TRC000080	X	
10	19	7	TRC100100	X	
12	22	7	TRCA00120	X	
12	24	7	TRCB00120	X	
12	28	7	TRCC00120	X	
12	32	7	TRC100120	X	
14	24	7	TRCA00140		
15	24	7	TRC000150	X	
15	26	7	TRCA00150	X	
15	28	7	TRC200150	X	
15	30	7	TRCB00150	X	
16	24	7	TRC000160	X	

The dimensions printed in **bold** type correspond to the recommendations in DIN 3760, draft September 1996.

() values in brackets are inch sizes.

Radial Oil Seal



Dimension			TSS Part No.	TSS	
d ₁	d ₂	b		NBR	FKM
16	28	7	TRCA00160		X
16	30	7	TRCB00160	X	
17	28	7	TRCA00170	X	
17	30	7	TRCB00170	X	
17	34	4	TRC000170	X	
17	35	7	TRCD00170	X	
18	24	4	TRC000180		X
20	30	7	TRCA00200	X	
20	32	7	TRCB00200	X	X
20	35	7	TRCC00200	X	
20	40	7	TRCD00200	X	
20	42	7	TRC300200	X	X
20	47	7	TRCE00200	X	
20	52	7	TRC400200	X	
22	32	7	TRCA00220	X	X
22	35	7	TRCB00220	X	
22.22 (0.87")	35.03 (1.38")	7.90 (0.31")	TRC000222	X	
24	35	7	TRCA00240	X	
25	35	7	TRCA00250	X	
25	37	7	TRC000250	X	
25	38	7	TRC100250	X	
25	40	7	TRCB00250	X	
25	47	7	TRCD00250	X	
25	52	7	TRCE00250	X	
26	37	7	TRCA00260	X	
26.5	47	7	TRC000265	X	
27	37	7	TRC000270	X	X
28	40	7	TRCA00280	X	
28	47	7	TRCB00280	X	
28	47	8	TRC200280	X	
30	40	7	TRCA00300	X	
30	42	7	TRCB00300	X	X
30	43	8	TRC600300	X	
30	45	8	TRC700300	X	X
30	47	7	TRCC00300	X	
30	50	7	TRC100300	X	

The dimensions printed in **bold** type correspond to the recommendations in DIN 3760, draft September 1996.
() values in brackets are inch sizes.



Radial Oil Seal

Dimension			TSS Part No.	TSS	
d ₁	d ₂	b		NBR	FKM
30	52	7	TRCD00300	X	
30	62	7	TRCE00300	X	
31.5	52	7	TRC000315	X	
32	42	7	TRC000320	X	X
32	45	7	TRCA00320	X	
32	47	7	TRCB00320	X	
32	52	7	TRCC00320	X	
34	52	10	TRC100340	X	
35	45	7	TRC000350	X	X
35	47	7	TRCA00350	X	
35	52	6	TRC300350	X	
35	52	7	TRCC00350	X	
35	52	8.8	TRCL00350	X	
35	55	12	TRCM00350	X	
35	57.2	10	TRCN00350	X	
35	62	7	TRCD00350	X	
35	62	12	TRC700350	X	X
35	72	10	TRC800350	X	
35	72	12	TRC900350	X	
38	52	7	TRCA00380	X	X
38	52	10	TRC100380	X	
38	54	10	TRC300380	X	
40	52	5.5	TRCI00400	X	
40	52	7	TRCA00400	X	
40	55	7	TRCB00400	X	
40	55	10	TRCG00400	X	
40	57.2	10	TRCJ00400	X	
40	58	12	TRCK00400	X	
40	62	7	TRCC00400	X	
40	65	9	TRCH00400	X	
40	72	7	TRCD00400	X	
41	56	7	TRC000410	X	
42	55	7	TRC000420	X	
42	62	10	TRC100420	X	
45	55	7	TRC000450	X	
45	59.1	10	TRCF00450	X	

The dimensions printed in **bold** type correspond to the recommendations in DIN 3760, draft September 1996.
 () values in brackets are inch sizes.

Radial Oil Seal



Dimension			TSS Part No.	TSS	
d ₁	d ₂	b		NBR	FKM
45	60	7	TRC100450	X	
45	60	8	TRCA00450	X	
45	62	8	TRCB00450	X	
45	65	10	TRC400450	X	
45	85	10	TRC800450	X	
48	62	8	TRCA00480	X	
48	62	10	TRC100480		X
48	75	8	TRC000480	X	
50	62	7	TRC000500	X	
50	65	8	TRCA00500	X	X
50	68	10	TRC900500	X	
50	72	8	TRCC00500	X	
50	72	10	TRC400500	X	
50	80	8	TRCD00500	X	
50	80	10	TRCF00500	X	
50	80	13	TRCG00500	X	
52	72	12	TRC100520	X	
55	70	8	TRCA00550	X	
55	72	8	TRCB00550	X	
55	72	10	TRC000550	X	
55	80	8	TRCC00550	X	
55	80	10	TRC200550	X	
55	85	8	TRCD00550	X	
56	72.6	9.7	TRC000560	X	
60	70	7	TRC000600	X	
60	72	8	TRC100600	X	
60	75	8	TRCA00600	X	
60	80	8	TRCB00600	X	
60	80	10	TRC200600	X	
60	85	8	TRCC00600	X	
60	90	13	TRC700600	X	
65	80	8	TRC000650	X	
65	85	10	TRCA00650	X	
65	90	10	TRCB00650	X	
65	90	13	TRC200650	X	
68	85	10	TRC000680	X	

The dimensions printed in **bold** type correspond to the recommendations in DIN 3760, draft September 1996.
 () values in brackets are inch sizes.



Radial Oil Seal

Dimension			TSS Part No.	TSS	
d ₁	d ₂	b		NBR	FKM
68	90	10	TRCA00680		X
70	85	8	TRC000700	X	
70	90	10	TRCA00700	X	
70	95	10	TRC300700	X	
70	95	13	TRC600700	X	
70	100	10	TRCB00700	X	
70	110	10	TRC200700	X	
75	95	5	TRC000750	X	
75	95	10	TRCA00750	X	
75	95	13	TRC200750	X	
75	100	10	TRCB00750	X	X
80	100	10	TRCA00800	X	
80	100	13	TRC000800	X	
80	110	10	TRCB00800	X	
80	110	12	TRC500800	X	
85	100	9	TRC000850	X	
85	105	10	TRC100850	X	
85	110	12	TRCA00850	X	
90	110	8	TRC000900	X	
90	110	12	TRCA00900	X	
90	120	12	TRCB00900	X	
95	110	9	TRC000950	X	
95	115	13	TRC100950	X	
95	120	12	TRCA00950	X	
96	135.7	12	TRC000960	X	
100	115	9	TRC001000	X	
100	120	8	TRC101000	X	X
100	120	10	TRC201000	X	
100	120	12	TRCA01000	X	
100	130	12	TRCC01000	X	X
105	125	12	TRC001050	X	
105	125	13	TRC201050	X	
105	130	12	TRCA01050	X	
110	130	12	TRCA01100	X	
110	140	12	TRCB01100	X	
110	150	15	TRC201100	X	

The dimensions printed in **bold** type correspond to the recommendations in DIN 3760, draft September 1996.
() values in brackets are inch sizes.

Radial Oil Seal



Dimension			TSS Part No.	TSS	
d ₁	d ₂	b		NBR	FKM
120	140	12	TRC301200	X	
120	140	13	TRC001200	X	
120	150	15	TRC101200		X
125	150	12	TRCA01250	X	
130	160	12	TRCA01300	X	
130	160	13	TRC001300	X	
140	160	13	TRC101400	X	
140	170	13	TRC201400		X
160	185	10	TRC101600	X	
160	190	15	TRCA01600	X	
170	200	15	TRCA01700	X	X
180	210	15	TRCA01800	X	X
260	300	20	TRCA02600	X	
270	310	16	TRC002700		X
275	294	12	TRC102750	X	
340	372	16	TRC103400	X	
350	380	16	TRC003500	X	
370	410	15	TRC003700	X	
460	500	20	TRCA04600	X	X

The dimensions printed in **bold** type correspond to the recommendations in DIN 3760, draft September 1996.
 () values in brackets are inch sizes.



Radial Oil Seal

■ Trelleborg Sealing Solutions type TRD

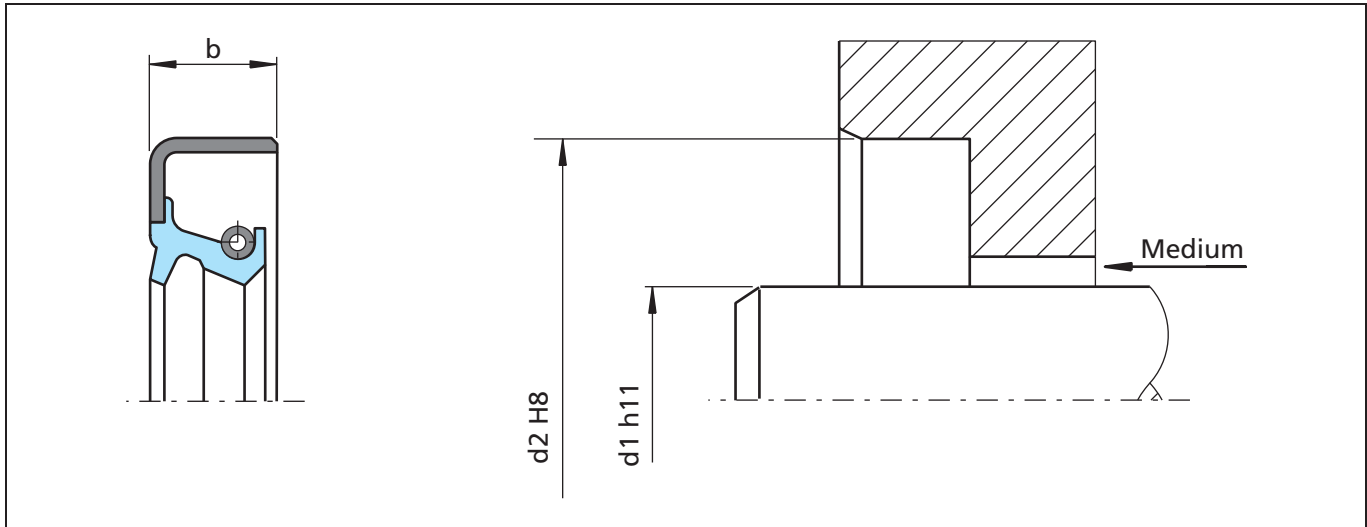

Figure 17 Installation drawing

General description

Trelleborg Sealing Solutions type TRD are metal cased radial lip seals. The additional dust lip protects the main sealing lip against dust and other fine solid contaminants and therefore this type is recommended for use in polluted environments. To achieve a long lifetime a suitable lubricant between the two sealing lips should be applied. As the static sealing between housing and metallic shell is somewhat limited, low viscosity media can "creep". Better performance can be achieved with epoxy based resin O.D. coating. This special treatment is on request.

Advantages

- Effective protection against air side contaminants
- Good radial stiffness, especially for large diameters
- Good fitting stability avoiding pop-out of the seal
- Modern lip design provides low radial forces
- Cost effective

Application examples

- Transmission systems (e.g. gearboxes)
- Pumps
- Electrical motors
- Machine tools
- Heavy engineering applications

Technical data

Pressure:	up to 0.05 MPa
Temperature:	-40°C to +200°C (depending on material)
Speed:	up to 30 m/s (depending on material)
Media:	mineral and synthetic lubricants (CLP, HLP, APGL etc.)

Trelleborg Sealing Solutions has carried out several thousands compatibility tests. Please ask for details.

Important Note:

The above data are maximum values and cannot be used at the same time, e. g. the maximum operating speed depends on material type, pressure and temperature.



Table XII Materials

Standard material*	TSS material code	Standard metal insert**	Standard spring**
NBR (70 Shore A)	N7MM	Carbon steel	Carbon steel
NBR (75 Shore A)	4N011		
FKM (70 Shore A)	VCBV	Carbon steel	Stainless steel
FKM (75 Shore A)	4V012		

* Special grades and other materials (ACM, EACM, EPDM, HNBR, VMQ) on request.

** Metal insert, and spring as well, can be supplied in different materials on request.

Ordering example oil seal TSS type

TSS type: D
 Code: TRD
 Dimensions: Shaft diameter 40 mm
 Housing diameter 52 mm
 Width 7 mm
 Material: NBR
 Material Code: N7MM

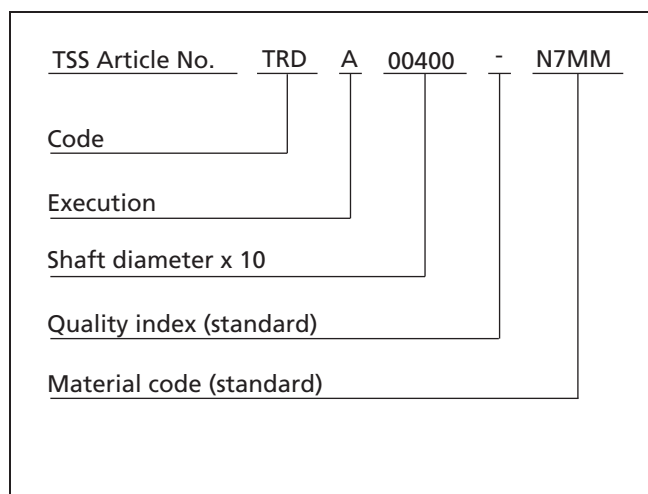

Table XIII Preferred series / Dimension, TSS part numbers

Dimension			TSS Part No.	TSS	
d ₁	d ₂	b		NBR	FKM
12	20	4	TRD300120	X	
12	20	5	TRD000120	X	
15	21	4	TRD000150	X	
15	24	7	TRD100150	X	
15	26	4	TRD200150	X	
15	26	6	TRD400150	X	
15	32	10	TRD300150	X	
17	28	5	TRD000170	X	
20	30	7	TRDA00200	X	
20	35	7	TRDC00200	X	
20	42	7	TRD000200	X	
22	40	7	TRDC00220	X	
25	32	7	TRD000250	X	
25	35	6	TRD200250		X
25	40	7	TRDB00250	X	

The dimensions printed in **bold** type correspond to the recommendations in DIN 3760, draft September 1996.



Radial Oil Seal

Dimension			TSS Part No.	TSS	
d ₁	d ₂	b		NBR	FKM
25	42	7	TRDC00250	X	
25	47	7	TRDD00250	X	
25	47	10	TRD100250	X	
25	52	7	TRDE00250	X	
26	40	7	TRD000260		X
30	42	7	TRDB00300	X	
30	50	7	TRD100300	X	
30	50	10	TRD200300	X	
30	52	10	TRD000300	X	
35	47	7	TRDA00350	X	
35	50	10	TRD000350	X	
35	50	12	TRD200350	X	
35	52	7	TRDC00350	X	
35	62	12	TRD100350	X	
38	50	7	TRD000380	X	
38	52	7	TRDA00380	X	
40	52	7	TRDA00400	X	
40	54	5.5	TRD400400	X	
40	55	7	TRDB00400	X	
40	60	10	TRD300400	X	
40	62	7	TRDC00400		X
40	90	10	TRD200400	X	
42	55	7	TRD000420	X	
42	58	7	TRD200420	X	
42	62	7	TRD100420	X	X
45	62	7	TRD100450	X	
45	62	8	TRDB00450	X	
45	62	10	TRD200450	X	
45	65	5	TRD300450	X	
45	72	8	TRDD00450	X	X
45	72	12	TRD000450	X	
48	62	7	TRD000480	X	
48	65	12	TRD100480	X	
48	70	9	TRD200480	X	
50	65	8	TRDA00500	X	
50	70	8	TRD100500	X	

The dimensions printed in **bold** type correspond to the recommendations in DIN 3760, draft September 1996.

Radial Oil Seal



Dimension			TSS Part No.	TSS	
d ₁	d ₂	b		NBR	FKM
50	90	10	TRD200500	X	
50.8	66.6	7.92	TRD000508	X	
52	65	9	TRD000520	X	
53.98	69.83	9.52	TRD000539	X	
54	72.5	9	TRD000540	X	
54	74	8	TRD100540	X	
55	70	8	TRDA00550	X	
55	72	10	TRD100550	X	
55	80	8	TRDC00550	X	
55	90	10	TRD000550	X	
57	72	9	TRD000570	X	
58	72	8	TRDA00580	X	
58	75	15	TRD000580	X	
60	80	8	TRDB00600	X	
60	80	10	TRD200600		X
60	80	13	TRD000600	X	
60	82	12	TRD100600	X	
61	85	13	TRD000610	X	
65	90	13	TRD100650	X	
65	100	13	TRD000650	X	
68	90	13	TRD000680	X	
70	85	8	TRD000700	X	
70	90	10	TRDA00700	X	
70	90	13	TRD200700	X	
70	100	12	TRD100700	X	
74	90	10	TRD000740	X	
75	95	12	TRD100750	X	
75	95	13	TRD200750		X
75	100	13	TRD000750	X	X
78	100	10	TRDA00780	X	
79	120	13	TRD000790	X	
80	100	12	TRD100800	X	
80	100	13	TRD200800	X	
80	105	13	TRD000800		X
85	115	13	TRD000850	X	
90	110	13	TRD000900	X	

The dimensions printed in **bold** type correspond to the recommendations in DIN 3760, draft September 1996.



Radial Oil Seal

Dimension			TSS Part No.	TSS	
d ₁	d ₂	b		NBR	FKM
90	115	12	TRD200900	X	
100	130	12	TRDC01000	X	
100	130	13	TRD001000	X	
105	130	13	TRD001050	X	
120	140	13	TRD001200	X	
120	150	12	TRDA01200	X	
120	150	14	TRD101200	X	
125	150	13	TRD001250	X	
130	160	13	TRD101300	X	
140	170	14	TRD001400	X	
140	170	15	TRDA01400	X	
145	170	13	TRD001450	X	
146	170	14	TRD001460	X	
148	170	14.5	TRD001480	X	
150	180	15	TRDA01500	X	
155	180	15	TRD001550	X	
160	180	10	TRD001600	X	
165	190	13	TRD001650		X
170	200	15	TRDA01700	X	
180	200	15	TRD001800	X	
190	220	12	TRD001900		X
200	240	20	TRD002000	X	
230	260	20	TRD002300	X	
265	290	16	TRD002650		X
270	310	16	TRD002700	X	
280	310	16	TRD202800		X
290	330	16	TRD002900	X	
400	440	20	TRDA04000	X	

The dimensions printed in **bold** type correspond to the recommendations in DIN 3760, draft September 1996.



■ Trelleborg Sealing Solutions type TRB

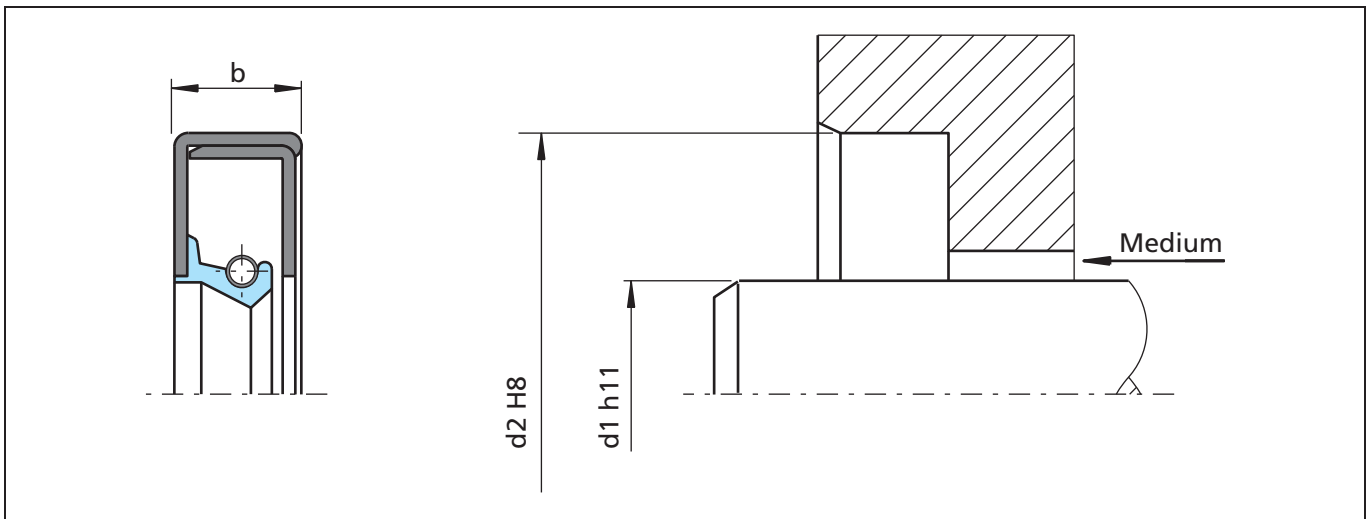

Figure 18 Installation drawing

General description

Trelleborg Sealing Solutions type TRB are reinforced metal cased radial lip seals. The supplementary metal inner ring provides a superior stiffness. This type is not recommended for use in heavily polluted environments. As the static sealing between housing and metallic shell is limited, low viscosity media can "creep". Better performance can be achieved with epoxy based resin O.D. coating. This special treatment is on request.

Advantages

- Superior radial stiffness, especially for very large diameters
- Very good fitting stability avoiding pop-out of the seal
- Modern lip design provides low radial forces
- Cost effective
- Suitable for use in combination with axial seal (V-Ring and GAMMA-seal)

Application examples

- Transmission systems (e.g. gearboxes)
- Pumps
- Electrical motors
- Machine tools
- Heavy engineering applications (e.g. mills in steel industry)

Technical data

Pressure:	up to 0.05 MPa
Temperature:	-40°C to +200°C (depending on material)
Speed:	up to 30 m/s (depending on material)
Media:	mineral and synthetic lubricants (CLP, HLP, APGL etc.)

Trelleborg Sealing Solutions has carried out several thousands compatibility tests. Please ask for details.

Important Note:

The above data are maximum values and cannot be used at the same time, e. g. the maximum operating speed depends on material type, pressure and temperature.



Radial Oil Seal

Table XIV Materials

Standard material*	TSS material Code	Standard metal insert**	Standard spring**
NBR (70 Shore A)	N7MM	Carbon steel	Carbon steel
NBR (75 Shore A)	4N011		
FKM (70 Shore A)	VCBV	Carbon steel	Stainless steel
FKM (75 Shore A)	4V012		

* Special grades and other materials (ACM, EACM, EPDM, HNBR, VMQ) on request.

** Metal insert, and spring as well, can be supplied in different materials on request.

Ordering example oil seal TSS type

TSS type: B
 Code: TRB
 Dimensions: Shaft diameter 45 mm
 Housing diameter 60 mm
 Width 10 mm
 Material: NBR
 Material Code: N7MM

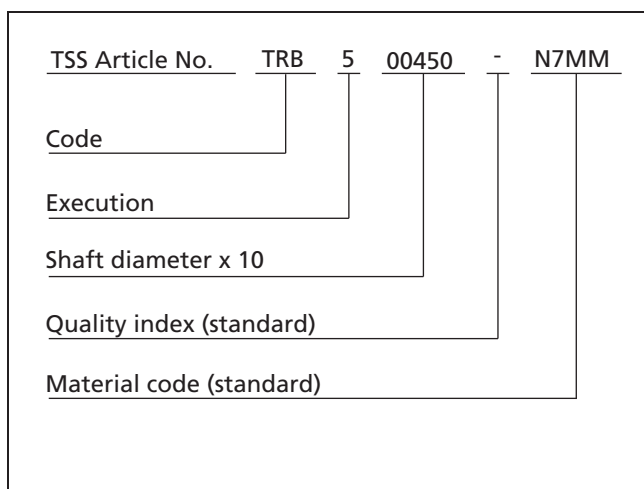

Table XV Preferred series / Dimension, TSS part numbers

Dimension			TSS Part No.	TSS	
d ₁	d ₂	b		NBR	FKM
20	47	10	TRB100200	X	
22	40	9	TRB200220	X	
22	47	9	TRB300220	X	
22	47	10	TRB000220	X	
25	35	7	TRBA00250	X	
25	45	10	TRB600250	X	
25	47	9	TRB700250	X	
25	50	10	TRB800250	X	
28	47	9	TRB000280	X	
30	47	9	TRB800300	X	
30	47	10	TRB100300	X	
30	50	10	TRB300300	X	

The dimensions printed in **bold** type correspond to the recommendations in DIN 3760, draft September 1996.

() values in brackets are inch sizes.

Radial Oil Seal



Dimension			TSS Part No.	TSS	
d₁	d₂	b		NBR	FKM
30	52	12	TRB200300	X	
35	50	9	TRB000350	X	
35	52	9	TRBG00350		
35	56	10	TRB300350		X
35	62	9	TRB600350	X	
35	62	10	TRB700350	X	
35	72	12	TRB800350	X	
35	80	13	TRBF00350	X	
38	55	12	TRB200380	X	
40	60	10	TRB200400	X	
40	62	9	TRB100400	X	
40	62	10	TRB300400	X	
40	62	12	TRB400400	X	
40	68	10	TRB700400	X	
40	68	12	TRB800400	X	X
40	90	9	TRB600400	X	
45	60	10	TRB500450	X	
45	62	10	TRB100450	X	
45	65	10	TRB200450	X	
45	72	10	TRB600450	X	
45	72	12	TRB000450	X	
45	75	10	TRBG00450	X	
48	65	12	TRB000480	X	
50	68	10	TRB200500	X	
50	70	10	TRB900500	X	
50	72	10	TRB600500	X	
50	72	12	TRB700500	X	
50	80	10	TRB800500	X	
50.80 (2.00")	73.10 (2.88")	12.70 (0.50")	TRB000508	X	
52	68	10	TRB100520	X	
52	72	10	TRB000520	X	
52	72	12	TRB200520	X	
52	80	13	TRB300520	X	
54	80	10	TRB000540	X	
55	72	10	TRB000550	X	
55	72	12	TRB600550	X	

The dimensions printed in **bold** type correspond to the recommendations in DIN 3760, draft September 1996.
() values in brackets are inch sizes.



Radial Oil Seal

Dimension			TSS Part No.	TSS	
d ₁	d ₂	b		NBR	FKM
55	80	10	TRB200550	X	
55	85	13	TRB800550	X	
55	100	13	TRB500550	X	
58	80	10	TRB000580	X	
60	75	8	TRBA00600	X	
60	80	10	TRB000600	X	X
60	85	10	TRB100600	X	
60	90	10	TRB300600	X	X
65	85	10	TRBA00650	X	
65	85	12	TRB000650	X	
65	90	10	TRBB00650	X	
65	90	12	TRB200650	X	
65.10 (2.56")	92.20 (3.63")	12.70 (0.50")	TRB000651	X	
66.70 (2.63")	88.50 (3.48")	12.70 (0.50")	TRB000667	X	
66.70 (2.63")	92.20 (3.63")	12.70 (0.50")	TRB100667	X	
68	90	10	TRBA00680	X	X
68	90	12	TRB000680	X	
69.85 (2.75")	90.12 (3.55")	12.70 (0.50")	TRB000698	X	
70	90	10	TRBA00700	X	
70	90	12	TRB000700	X	X
70	95	10	TRB300700	X	
70	100	12	TRB200700	X	
70	105	13	TRB400700	X	
73.02 (2.87")	95.40 (3.76")	12.70 (0.50")	TRB100730	X	
74	90	10	TRB000740	X	
75	90	10	TRB600750		X
75	95	12	TRB500700	X	X
75	100	10	TRBB00750	X	
75	100	12	TRB400750	X	X
75	110	13	TRB200750	X	
75	115	13	TRB300750	X	
76.20 (3.00")	95.40 (3.76")	12.70 (0.50")	TRB000762	X	
76.20 (3.00")	98.60 (3.88")	11.90 (0.47")	TRB100762	X	
76.20 (3.00")	101.80 (4.00")	11.90 (0.47")	TRB200762	X	
80	100	10	TRBA00800	X	
80	100	12	TRB000800	X	X

The dimensions printed in **bold** type correspond to the recommendations in DIN 3760, draft September 1996.
() values in brackets are inch sizes.

Radial Oil Seal



Dimension			TSS Part No.	TSS	
d ₁	d ₂	b		NBR	FKM
80	100	13	TRB600800	X	
80	105	13	TRB100800	X	
80	110	12	TRB200800	X	
80	120	13	TRB400800	X	
85	105	13	TRB500850	X	
85	110	12	TRBA00850		X
85	110	13	TRB100850	X	X
85	110	15	TRB600850	X	
85	115	13	TRB200850	X	
85	130	13	TRB400850	X	
85.72 (3.37")	108.05 (4.25")	12.70 (0.50")	TRB000857	X	
90	110	8	TRB000900	X	
90	110	12	TRBA00900		X
90	110	13	TRB200900	X	
90	120	13	TRB300900	X	
90	120	15	TRB400900	X	
90	130	13	TRB500900	X	
90	140	13	TRB600900	X	
95	115	13	TRB000950	X	
95	120	12	TRBA00950		X
95	120	13	TRB100950	X	X
95	120	15	TRB500950	X	
95	125	13	TRB200950	X	
95	125	15	TRB600950	X	
95	130	13	TRB300950	X	
98.42 (3.87")	120.81 (4.76")	12.70 (0.50")	TRB000984	X	
98.42 (3.87")	127.10 (5.00")	11.91 (0.47")	TRB100984	X	
100	115	9	TRB001000		X
100	120	12	TRBA01000		X
100	120	13	TRB101000	X	
100	125	13	TRB501000	X	
100	130	13	TRB201000	X	
100	140	13	TRB601000	X	
101.60 (4.00")	127.10 (5.00")	12.70 (0.50")	TRB101016	X	X
105	125	13	TRB001050	X	
105	130	13	TRB101050	X	

The dimensions printed in **bold** type correspond to the recommendations in DIN 3760, draft September 1996.
() values in brackets are inch sizes.



Radial Oil Seal

Dimension			TSS Part No.	TSS	
d ₁	d ₂	b		NBR	FKM
105	130	15	TRB201050	X	
105	140	15	TRB501050	X	
110	130	13	TRB101100	X	
110	130	15	TRB601100	X	
110	140	13	TRB501100	X	
110	140	15	TRB301100	X	
110	145	15	TRB701100	X	
110	150	13	TRB401100	X	
110	150	15	TRB001100	X	
114.30 (4.50")	139.85 (5.50")	12.70 (0.50")	TRB001143	X	
115	140	13	TRB001150	X	
115	140	15	TRB101150	X	
115	150	15	TRB201150	X	
120	140	13	TRB001200	X	
120	145	14.5	TRB501200	X	
120	150	13	TRB101200	X	
120	150	15	TRB201200	X	X
120	160	13	TRB301200	X	
120	160	15	TRB401200	X	X
125	150	13	TRB001250	X	
125	150	15	TRB301250	X	
125	160	15	TRB501250	X	
127.00 (5.00")	158.90 (6.25")	12.70 (0.50")	TRB001270	X	
130	160	13	TRB101300	X	
130	160	15	TRB401300	X	X
130	170	15	TRB501300	X	
130	180	15	TRB301300	X	
135	160	13	TRB001350	X	
135	160	15	TRB101350	X	
135	170	15	TRB201350	X	
140	160	13	TRB001400	X	
140	165	12	TRB401400	X	
140	170	13	TRB101400	X	
140	170	15	TRBA01400	X	X
140	180	15	TRB201400	X	
140	190	15	TRB301400	X	

The dimensions printed in **bold** type correspond to the recommendations in DIN 3760, draft September 1996.
() values in brackets are inch sizes.

Radial Oil Seal



Dimension			TSS Part No.	TSS	
d ₁	d ₂	b		NBR	FKM
145	165	13	TRB001450	X	
145	170	13	TRB101450	X	
145	170	15	TRB201450	X	
145	175	15	TRBA01450	X	
145	180	15	TRB301450	X	
150	170	15	TRB201500	X	
150	180	13	TRB001500	X	
150	180	15	TRBA01500	X	X
155	180	15	TRB001550	X	
160	180	15	TRB001600	X	
160	185	10	TRB101600	X	
160	190	15	TRBA01600	X	X
165	190	13	TRB001650	X	
165	190	15	TRB101650	X	
165.10 (6.50")	193.88 (7.63")	15.75 (0.62")	TRB001651	X	
170	190	15	TRB101700	X	
170	200	15	TRBA01700	X	X
174.60 (6.87")	200.23 (7.88")	15.90 (0.63")	TRB001746	X	
175	200	15	TRB001750	X	
175	205	15	TRB101750	X	
180	210	15	TRBA01800	X	
180	220	16	TRB001800	X	
190	215	16	TRB001900	X	
190	220	15	TRBA01900	X	
200	230	15	TRBA02000	X	X
200	230	16	TRB102000	X	
200	250	15	TRB002000	X	
210	240	15	TRBA02100	X	X
220	250	15	TRB002200	X	
230	260	15	TRBA02300	X	
240	270	15	TRBA02400	X	X
250	280	15	TRBA02500	X	
260	290	16	TRB002600	X	X
260	300	20	TRBA02600	X	X
280	310	16	TRB002800	X	X
280	320	20	TRBA02800	X	X

The dimensions printed in **bold** type correspond to the recommendations in DIN 3760, draft September 1996.
 () values in brackets are inch sizes.



Radial Oil Seal

Dimension			TSS Part No.	TSS	
d ₁	d ₂	b		NBR	FKM
290	330	18	TRB202900	X	
300	332	16	TRB003000	X	
300	340	20	TRBA03000	X	
310	350	18	TRB003100	X	X
320	350	18	TRB003200	X	
320	360	18	TRB103200	X	
320	360	20	TRBA03200	X	
330	370	18	TRB003300	X	
340	372	16	TRB003400	X	
340	380	20	TRBA03400	X	X
350	390	18	TRB003500	X	
360	400	18	TRB003600	X	
360	400	20	TRBA03600	X	X
365	405	18	TRB003650	X	
374.65 (14.75")	419.00 (16.50")	22.20 (0.87")	TRB003746	X	
380	420	20	TRBA03800	X	X
390	430	18	TRB003900	X	
400	440	20	TRBA04000	X	X
420	460	20	TRBA04200	X	
440	470	20	TRB004400	X	
440	480	20	TRBA04400	X	X
460	500	20	TRBA04600	X	
480	520	20	TRBA04800	X	
500	540	20	TRBA05000	X	
560	610	20	TRB005600		X
600	640	20	TRB006000		X
700	750	25	TRB007000	X	
760	800	20	TRB107600	X	

The dimensions printed in **bold** type correspond to the recommendations in DIN 3760, draft September 1996.
() values in brackets are inch sizes.



■ Trelleborg Sealing Solutions type TRF

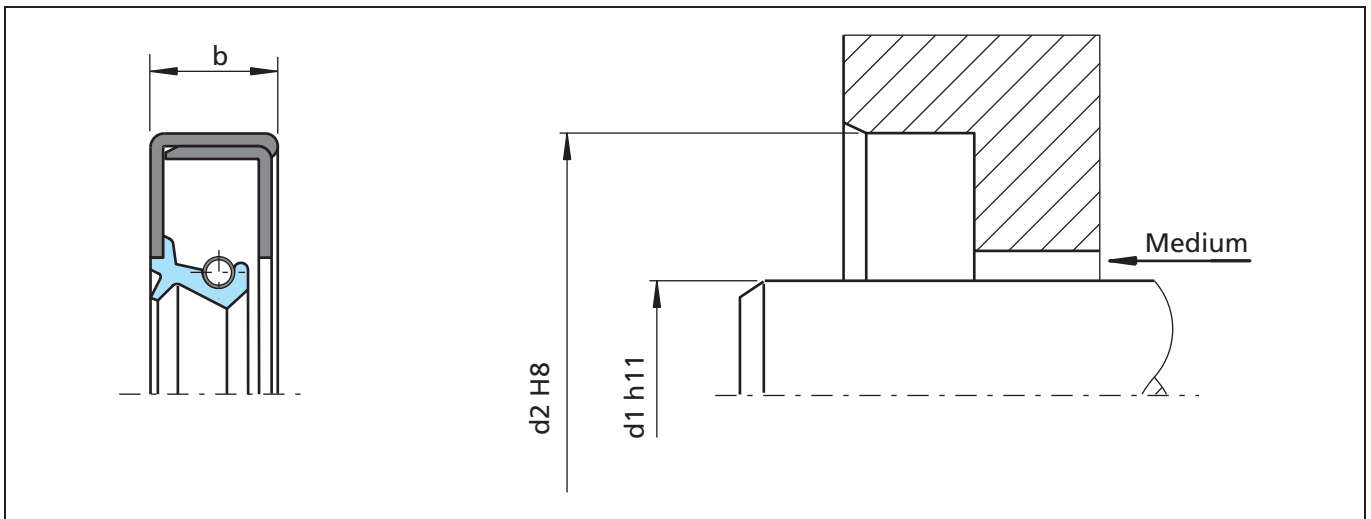

Figure 19 Installation drawing

General description

Trelleborg Sealing Solutions type TRF are reinforced metal cased radial lip seals with dust lip. The supplementary metal inner ring provides a superior stiffness. This type is recommended for use in heavily polluted environments. To achieve a long lifetime a suitable lubricant between the two sealing lips should be applied. As the static sealing between housing and metallic shell is limited, low viscosity media can "creep". Better performance can be achieved with epoxy based resin O.D. coating. This special treatment is on request.

Advantages

- Superior radial stiffness, especially for very large diameters
- Very good fitting stability avoiding pop-out of the seal
- Modern lip design provides low radial forces
- Cost effective
- Suitable for use in combination with axial seal (V-Ring and GAMMA-seal)

Application examples

- Transmission systems (e.g. gearboxes)
- Pumps
- Electrical motors
- Machine tools
- Heavy engineering applications (e.g. mills in steel industry)

Technical data

Pressure:	up to 0.05 MPa
Temperature:	-40°C to +200°C (depending on material)
Speed:	up to 30 m/s (depending on material)
Media:	mineral and synthetic lubricants (CLP, HLP, APGL etc.)

Trelleborg Sealing Solutions has carried out several thousands compatibility tests. Please ask for details.

Important Note:

The above data are maximum values and cannot be used at the same time, e. g. the maximum operating speed depends on material type, pressure and temperature.



Radial Oil Seal

Table XVI Materials

Standard material*	TSS material code	Standard metal insert**	Standard spring**
NBR (70 Shore A)	N7MM	Carbon steel	Carbon steel
NBR (75 Shore A)	4N011		
FKM (70 Shore A)	VCBV	Carbon steel	Stainless steel
FKM (75 Shore A)	4V012		

* Special grades and other materials (ACM, EACM, EPDM, HNBR, VMQ) on request.

** Metal insert, and spring as well, can be supplied in different materials on request.

Ordering example oil seal TSS type

TSS type: F
 Code: TRF
 Dimensions: Shaft diameter 110 mm
 Housing diameter 140 mm
 Width 13 mm
 Material: NBR
 Material Code: N7MM

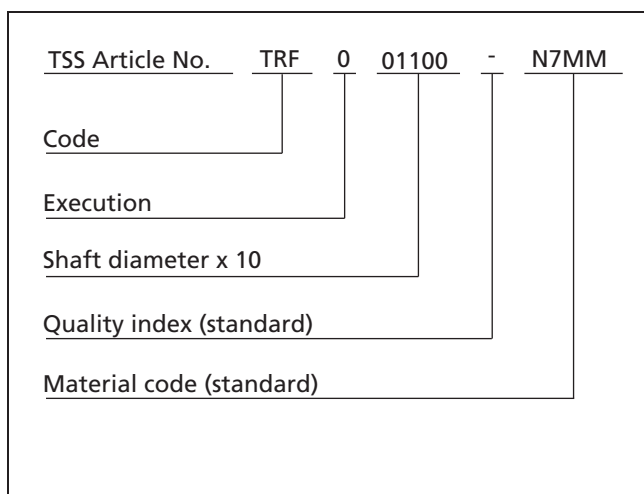

Table XVII Preferred series / Dimension, TSS part numbers

Dimension			TSS Part No.	TSS	
d ₁	d ₂	b		NBR	FKM
35	52	9	TRF000350	X	
45	62	10	TRF100450	X	
45	62	12	TRF000450	X	
50.80 (2.00")	73.13 (2.88")	12.70 (0.50")	TRF000508	X	
58	80	13	TRF000580	X	
60	80	8	TRFB00600	X	
60	80	10	TRF100600	X	
60	80	12	TRF000600	X	
60	90	10	TRF200600	X	
66.7	98.5	11.9	TRF000667	X	
70	90	12	TRF000700	X	
80	100	10	TRFA00800		X

The dimensions printed in **bold** type correspond to the recommendations in DIN 3760, draft September 1996.

() values in brackets are inch sizes.

Radial Oil Seal



Dimension			TSS Part No.	TSS	
d ₁	d ₂	b		NBR	FKM
80	100	12	TRF000800	X	
90	120	13	TRF000900	X	
90	130	13	TRF100900	X	
95	120	13	TRF100950	X	
100	125	13	TRF001000	X	
100	130	13	TRF101000		X
105	140	13	TRF001050	X	
110	140	13	TRF001100	X	X
115	140	11	TRF001150	X	
120	140	13	TRF001200		X
120	150	15	TRF101200	X	
125	150	12	TRFA01250		X
130	155	10	TRF001300	X	
130	170	15	TRF101300	X	
132	160	13	TRF001320	X	
140	170	15	TRFA01400	X	
148	170	15	TRF001480	X	
150	180	15	TRFA01500	X	
160	190	15	TRFA01600	X	
170	200	15	TRFA01700	X	
175	200	15	TRF001750	X	
180	210	15	TRFA01800		X
180	215	15	TRF001800	X	
200	225	15	TRF102000	X	
240	270	15	TRFA02400	X	X
250	275	15	TRF002500	X	
275	300	15	TRF002750	X	
275	310	16	TRF102750		X
280	310	16	TRF002800	X	X
280	320	20	TRFA02800	X	
350	390	18	TRF003500	X	
380	420	20	TRF003800	X	X
390	425	18	TRF003900	X	
460	500	20	TRFA04600	X	
600	640	20	TRF006000		X

The dimensions printed in **bold** type correspond to the recommendations in DIN 3760, draft September 1996.
 () values in brackets are inch sizes.



Special types of rotary seals

When the seals designed according to the standard of Figure 13, are not able to satisfy the application's specification, special seals are available. The selection guide in Table IV shows the range of seals suitable to fulfill the majority of

industrial applications and meeting DIN 3760/3761 requirements as well. Special seals include:

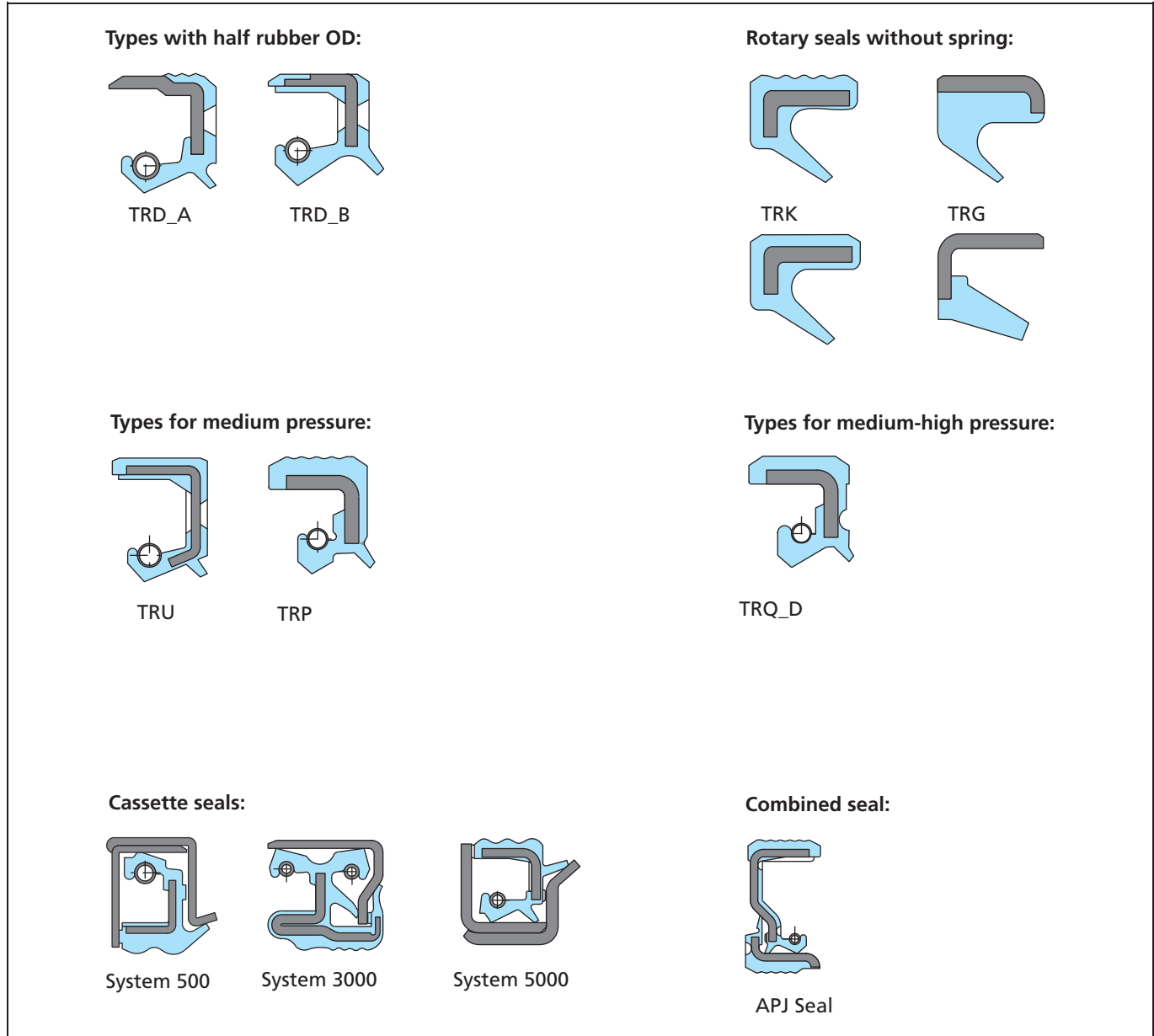

Figure 20 Selection of special radial seals



■ Trelleborg Sealing Solutions types TRD_A / TRD_B

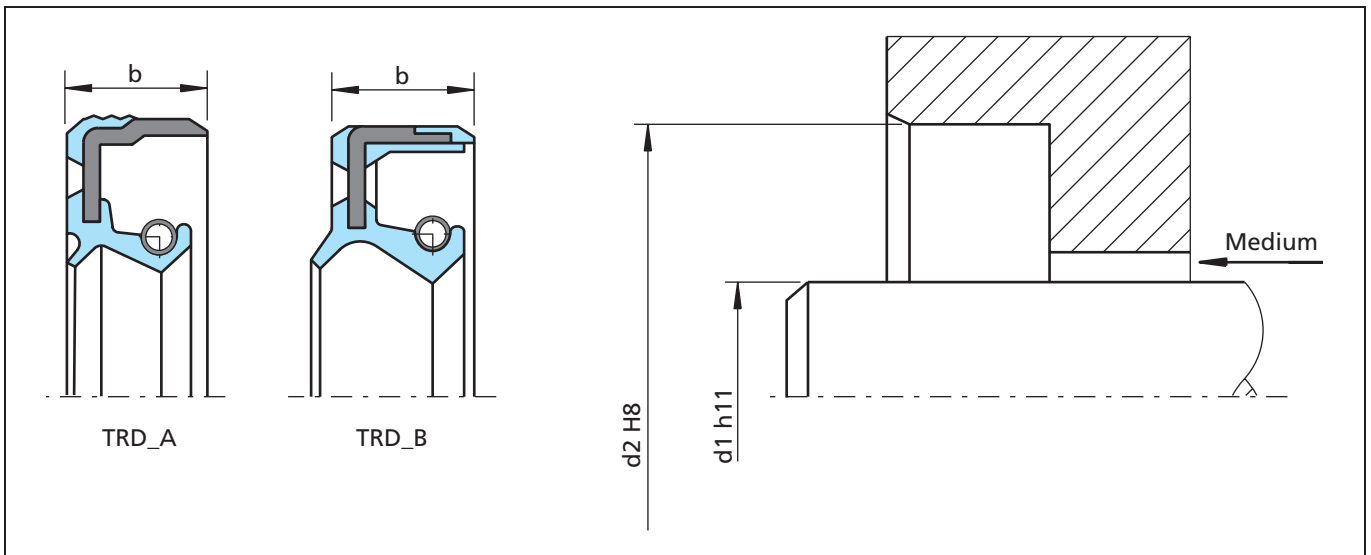

Figure 21 Installation drawing

General description

Trelleborg Sealing Solutions types TRD_A / TRD_B are seals with partially rubber covered Outer Diameter. These seals are designed to assure a high assembly stiffness and a good static sealing together with a good heat transfer. The additional dust lip protects the main sealing lip against dust and other fine solid contaminants, therefore these types are recommended for use in polluted environments. To achieve a long lifetime a suitable lubricant between the two sealing lips should be applied.

Please note that this O.D. design (half & half design) can be delivered on request also for different sealing lip types (e.g. type TRA,TRP, etc.)

Advantages

- Good static sealing and stiffness (No pop-out effect)
- Good thermal expansion compensation
- Good heat transfer
- Effective protection against air side contaminants

Application examples

- Automotive "Power-train" and "Drive-train"
- Automotive servo-pumps
- High speed transmission
- Machine tools

Technical data

Pressure:	up to 0.05 MPa for standard lip profiles
Temperature:	-40 °C to +200 °C (depending on material)
Speed:	up to 30 m/s (depending on material)
Media:	mineral and synthetic oils (CLP, HLP, APGL etc.)

Trelleborg Sealing Solutions has carried out several thousands compatibility tests. Please ask for details.

Important Note:

The above data are maximum values and cannot be used at the same time, e. g. the maximum operating speed depends on material type, pressure and temperature.



Radial Oil Seal

Table XVIII Materials

Standard material*	TSS material code	Standard metal insert**	Standard spring**
NBR (70 Shore A)	N7MM	Carbon steel	Carbon steel
NBR (75 Shore A)	4N011		
FKM (70 Shore A)	VCBV	Carbon steel	Stainless steel
FKM (75 Shore A)	4V012		

* Special grades and other materials (ACM, EACM, EPDM, HNBR, VMQ) on request.

** Metal insert, and spring as well, can be supplied in different materials on request.

Remark: These seals are customer tailored products.

For more details please contact your local Trelleborg Sealing Solutions marketing company.



■ Trelleborg Sealing Solutions type TRU - medium pressure oil seal

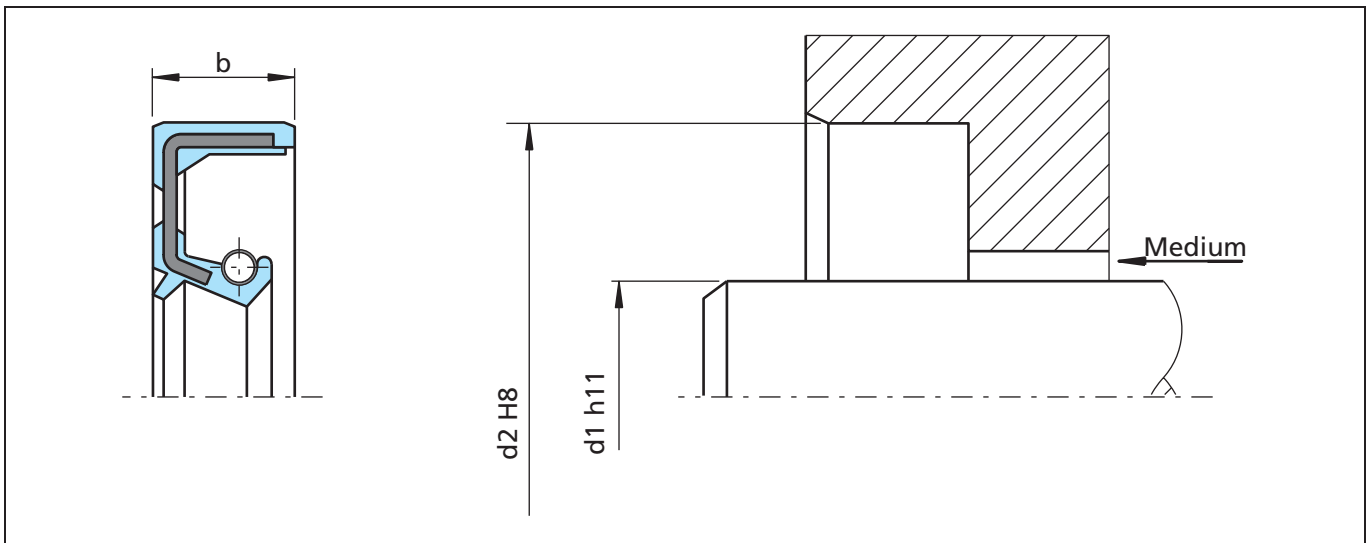

Figure 22 Installation drawing

General description

Trelleborg Sealing Solutions type TRU is a seal with completely rubber covered outer diameter. This type of seal is designed with an extended metallic support of the diaphragm that allows pressures up to 0.5 MPa. In order to avoid a "pop-out" of the seal, we suggest to fit an axial retainer (e.g. circlip, shoulder, etc.). The additional dust lip protects the main sealing lip against dust and other fine solid contaminants and therefore this type is recommended for use in polluted environments. To achieve a long lifetime a suitable lubricant between the two sealing lips should be applied.

Advantages

- Good static sealing
- Compensation of different thermal expansion
- Reduced risk of fretting corrosion
- Up to 0.5 MPa pressure at moderate peripheral speed
- Effective protection against air side contaminants
- No need of back-up ring

Application examples

- Transmission systems (e.g. gearboxes)
- Pumps
- Hydraulic motors
- Machinery industry

Technical data

Pressure:	up to 0.5 MPa
Temperature:	-40°C to +200°C (depending on material)
Speed:	up to 10 m/s (depending on pressure and material)
Media:	mineral and synthetic lubricants (CLP, HLP, APGL etc.)

Trelleborg Sealing Solutions has carried out several thousands compatibility tests. Please ask for details.

Important Note:

The above data are maximum values and cannot be used at the same time, e. g. the maximum operating speed depends on material type, pressure and temperature.



Radial Oil Seal

Table XIX Materials

Standard material*	TSS material code	Standard metal insert**	Standard spring**
NBR (70 Shore A)	N7MM	Carbon steel	Carbon steel
FKM (70 Shore A)	VCBV	Carbon steel	Stainless steel

* Special grades and other materials (ACM, EACM, EPDM, HNBR, VMQ) on request.
 ** Metal insert, and spring as well, can be supplied in different materials on request.

Ordering example oil seal TSS type

TSS type: U
 Code: TRU
 Dimensions: Shaft diameter 40 mm
 Housing diameter 52 mm
 Width 7 mm
 Material: NBR
 Material Code: N7MM

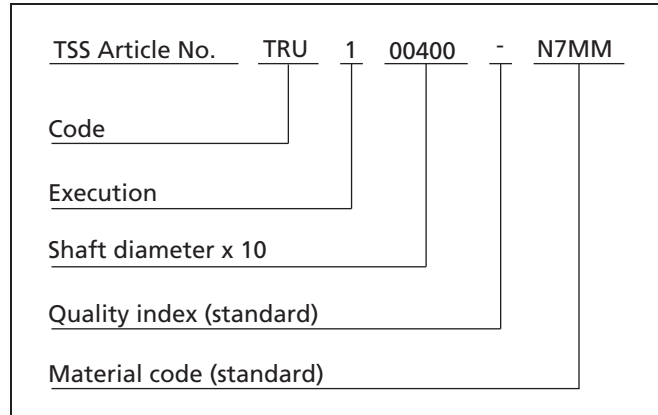

Table XX Preferred series / Dimension, TSS part numbers

Dimension			TSS Part No.	TSS	
d ₁	d ₂	b		NBR	FKM
8	22	7	TRU000080	X	
12	22	6	TRU200120	X	
12	22	7	TRU000120	X	
15	25	6	TRU100150		X
16	28	6	TRU000160		X
17	28	6	TRU000170	X	
20	30	7	TRU200200	X	
20	35	6	TRU300200	X	
20	35	7	TRU100200	X	
20	40	6	TRU000200	X	
22	32	7	TRU100220	X	
22	42	7	TRU200220	X	
22	47	7	TRU000220	X	X
23	40	6	TRU000230		X
25	40	7	TRU000250	X	X
28	40	6	TRU000280		X
28	47	7	TRU100280	X	
29	40	6	TRU000290		X

Radial Oil Seal



Dimension			TSS Part No.	TSS	
d ₁	d ₂	b		NBR	FKM
30	42	6	TRU000300	X	X
30	47	7	TRU200300	X	
30	47	8	TRU100300	X	
35	47	7	TRU000350		X
35	50	7.5	TRU300350	X	
35	52	6	TRU100350	X	X
35	56	12	TRU200350	X	
37	47	6	TRU000370		X
40	52	5	TRU000400	X	X
40	52	7	TRU100400	X	
40	55	7	TRUB00400		X
40	55	8	TRU200400	X	
40	56	6	TRU300400	X	X
42	62	7	TRU000420	X	
45	62	7	TRU000450		X
45	65	7	TRU200450	X	
45	65	8	TRU100450	X	
46	60	6	TRU000460		X
47	62	7	TRU000470	X	
50	65	8	TRU200500	X	
50	68	8	TRU000500	X	
50	72	7	TRU100500	X	X
55	72	7	TRU000550		X
55	72	8	TRU200550	X	
55	75	7	TRU100550		X
58	80	10	TRU000580		X
60	75	8	TRU100600		X
60	80	7	TRU000600	X	X
65	85	10	TRU000650	X	
70	90	7	TRU100700	X	
70	90	10	TRU000700		X
80	100	7	TRU000800	X	
85	105	12	TRU000850	X	
90	110	7.5	TRU000900		X
90	110	12	TRU200900	X	
90	125	12	TRU100900	X	



Radial Oil Seal

Dimension			TSS Part No.	TSS	
d ₁	d ₂	b		NBR	FKM
95	120	12	TRU000950	X	
100	120	12	TRU001000	X	
120	140	13	TRU001200	X	
120	150	12	TRU101200	X	
135	165	15	TRU001350	X	
140	170	12	TRU001400	X	
140	170	15	TRU101400	X	
160	185	8.5	TRU101600	X	
160	190	15	TRU001600	X	
190	213	8	TRU001900		X
200	230	15	TRU002000	X	



■ Trelleborg Sealing Solutions type TRP - medium pressure oil seal

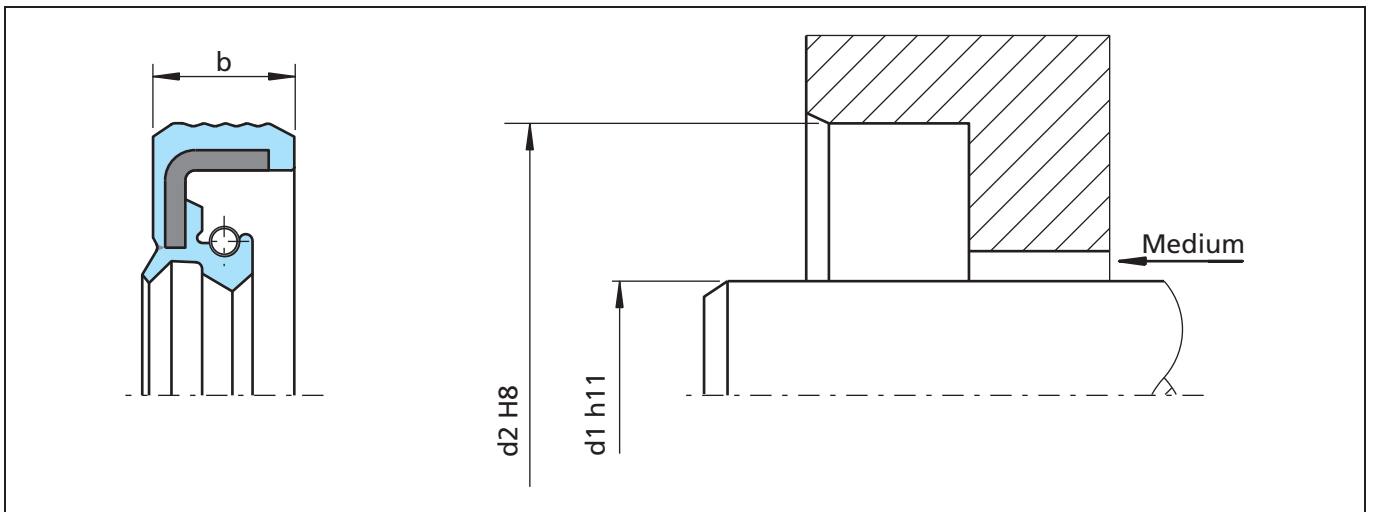

Figure 23 Installation drawing

General description

Trelleborg Sealing Solutions type TRP are seals with completely rubber covered Outer Diameter. This type of seal is designed for pressures up to 0.5 MPa. In order to avoid a “pop-out” of the seal, we suggest to fit an axial retainer (e.g. circlip, shoulder, etc.) The additional dust lip protects the main sealing lip against dust and other fine solid contaminants and therefore this type is recommended for use in polluted environments. To achieve a long lifetime a suitable lubricant between the two sealing lips should be applied.

Advantages

- Good static sealing
- Compensation of different thermal expansion
- Reduced risk of fretting corrosion
- Up to 0.5 MPa pressure at moderate peripheral speed
- Low lip and shaft wear at low pressure run
- Effective protection against air side contaminants
- No need of back-up ring

Application examples

- Transmission systems (e.g. gearboxes)
- Pumps
- Hydraulic motors
- Machinery industry

Technical data

Pressure:	up to 0.5 MPa
Temperature:	-40 °C to +200 °C (depending on material)
Speed:	up to 10 m/s (depending on pressure and material)
Media:	mineral and synthetic lubricants (CLP, HLP, APGL etc.)

Trelleborg Sealing Solutions has carried out several thousands compatibility tests. Please ask for details.

Important Note:

The above data are maximum values and cannot be used at the same time, e. g. the maximum operating speed depends on material type, pressure and temperature.



Radial Oil Seal

Table XXI Materials

Standard material*	TSS material code	Standard metal insert**	Standard spring**
NBR (70 Shore A)	N7MM	Carbon steel	Carbon steel
NBR (75 Shore A)	4N011		
FKM (70 Shore A)	VCBV	Carbon steel	Stainless steel
FKM (75 Shore A)	4V012		

* Special grades and other materials (ACM, EACM, EPDM, HNBR, VMQ) on request.

** Metal insert, and spring as well, can be supplied in different materials on request.

Ordering example oil seal TSS type

TSS type: P
 Code: TRP
 Dimensions: Shaft diameter 50 mm
 Housing diameter 72 mm
 Width 7 mm
 Material: NBR
 Material Code: N7MM

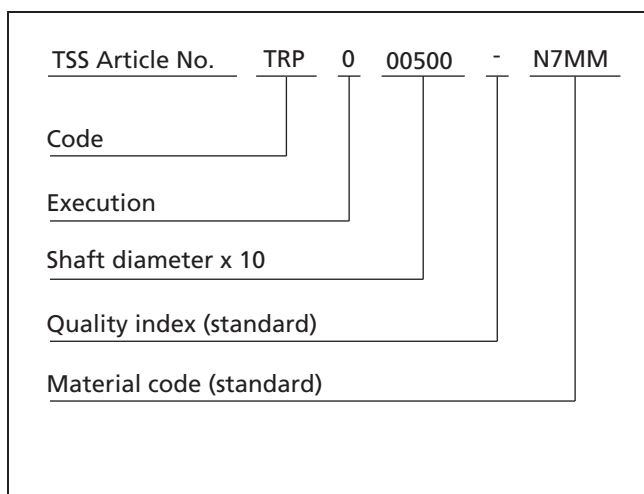

Table XXII Preferred series / Dimension, TSS part numbers

Dimension			TSS Part No.	TSS	
d ₁	d ₂	b		NBRM	FKM
10	22	7	TRP000100	X	
11	22	7	TRPA00110	X	
12	22	6	TRP000120	X	X
13	22	5	TRP000130		X
17	28	7	TRP100170	X	
17	30	7	TRP000170		X
19	27	5	TRP000190	X	
19	32	6	TRP100190		X
20	35	6	TRP100200	X	
20	40	7	TRP000200		X
20	45	6	TRP200200	X	
22	32	6	TRP100220	X	X
22	40	6	TRP000220		X
24	40	7	TRPC00240	X	X
25	35	6	TRP100250	X	X

Radial Oil Seal



Dimension			TSS Part No.	TSS	
d ₁	d ₂	b		NBRM	FKM
25	37	6	TRP200250	X	X
25	40	7	TRP000250		X
28	40	6	TRP000280		X
30	42	6	TRP000300	X	X
33	45	5	TRP000330		X
35	47	6	TRP100350	X	X
35	52	6	TRP000350	X	X
36	48	5.5	TRP000360	X	
40	55	7	TRPB00400	X	X
40	62	6	TRP100400	X	
40	67	7	TRP000400		X
42	62	7	TRP000420		X
45	62	7	TRP000450	X	
50	72	7	TRP000500	X	X
52	68	10	TRP000520		X
55	70	7	TRP000550	X	
55	72	7	TRP100550	X	
60	80	7	TRP000600	X	X
70	90	7	TRP000700	X	X
80	100	7	TRP000800		X
85	105	7.5	TRP000850	X	
100	118	7.5	TRP001000	X	
105	125	13	TRP001050		X
155	174	12	TRP001550		X
190	220	12	TRP001900	X	
280	320	16	TRP002800	X	
365	400	12	TRP003650	X	
365	405	15	TRP103650	X	
460	490	12	TRP004600		X



Radial Oil Seal

■ Trelleborg Sealing Solutions type TRQ - medium - high pressure oil seal

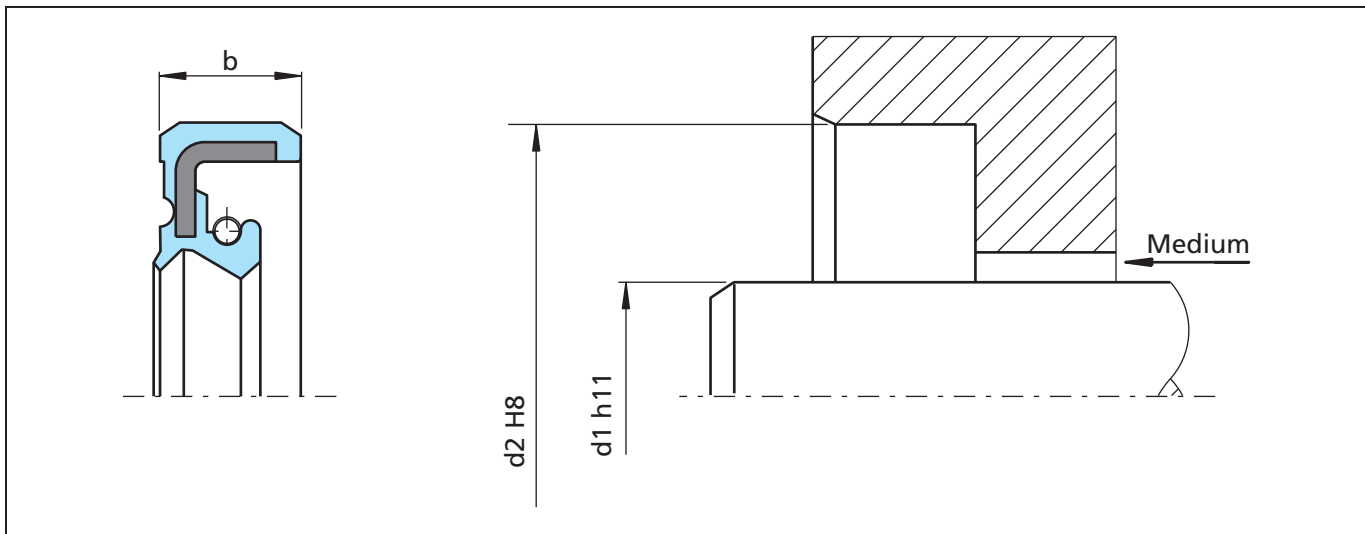

Figure 24 Installation drawing

General description

STEFA type 12 CC (TRQ_D) is a seal with completely rubber covered Outer Diameter. This type of seal is designed for pressures up to 1 MPa. In order to avoid a "pop-out" of the seal, we suggest to fit an axial retainer (e.g. circlip, shoulder, etc.). The additional dust lip protects the main sealing lip against dust and other fine solid contaminants and therefore this type is recommended for use in polluted environments. To achieve a long lifetime a suitable lubricant between the two sealing lips should be applied.

Advantages

- Good static sealing
- Compensation of different thermal expansion
- Reduced risk of fretting corrosion
- Up to 1 MPa pressure at low peripheral speed
- Effective protection against air side contaminants
- No need of back-up ring.

Application examples

- Transmission systems (e.g. gearboxes)
- Pumps
- Hydraulic motors
- Machinery industry

Technical data

Pressure:	up to 1 MPa
Temperature:	-40°C to +200°C (depending on material)
Speed:	up to 5 m/s (depending on pressure and material)
Media:	mineral and synthetic lubricants (CLP, HLP, APGL etc.)

Trelleborg Sealing Solutions has carried out several thousands compatibility tests. Please ask for details.

Important Note:

The above data are maximum values and cannot be used at the same time, e. g. the maximum operating speed depends on material type, pressure and temperature.



Table XXIII Materials

Standard material*	TSS material code	Standard metal insert**	Standard spring**
NBR (75 Shore A)	4N011	Carbon steel	Carbon steel
FKM (75 Shore A)	4V012	Carbon steel	Stainless steel

* Special grades and other materials (ACM, EACM, EPDM, HNBR, VMQ) on request.

** Metal insert, and spring as well, can be supplied in different materials on request.

Ordering example oil seal STEFA type

STEFA type: 12CC
 Code: TRQ_D
 Dimensions: Shaft diameter 24 mm
 Housing diameter 40 mm
 Width 6 mm
 Material: NBR 1452
 Material Code: 4N011

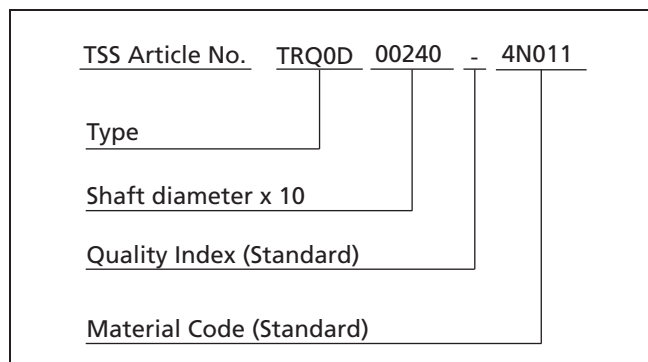

Table XXIV Preferred series / Dimension, TSS part numbers

Dimension			TSS Part No.	TSS	
d ₁	d ₂	b		NBR	FKM
15	25	6	TRQ0D0150	X	
19.5	30	6	TRQ0D0195		X
24	40	6	TRQ0D0240	X	
27	44	7	TRQ0D0270	X	
32	47	6	TRQ0D0320		X
32	48	7	TRQ1D0320	X	
35	52	6	TRQ1D0350		X
35	54	6	TRQ0D0350		X
40	55	7	TRQBD0400		X
45	62	7	TRQ0D0450		X
47	62	7	TRQ0D0470	X	
50	72	7	TRQ0D0500		X
55	70	7	TRQ0D0550		X
55	83	7	TRQ1D0550	X	
60	80	7	TRQ0D0600		X
70	90	7	TRQ0D0700		X



■ Trelleborg Sealing Solutions type TRK

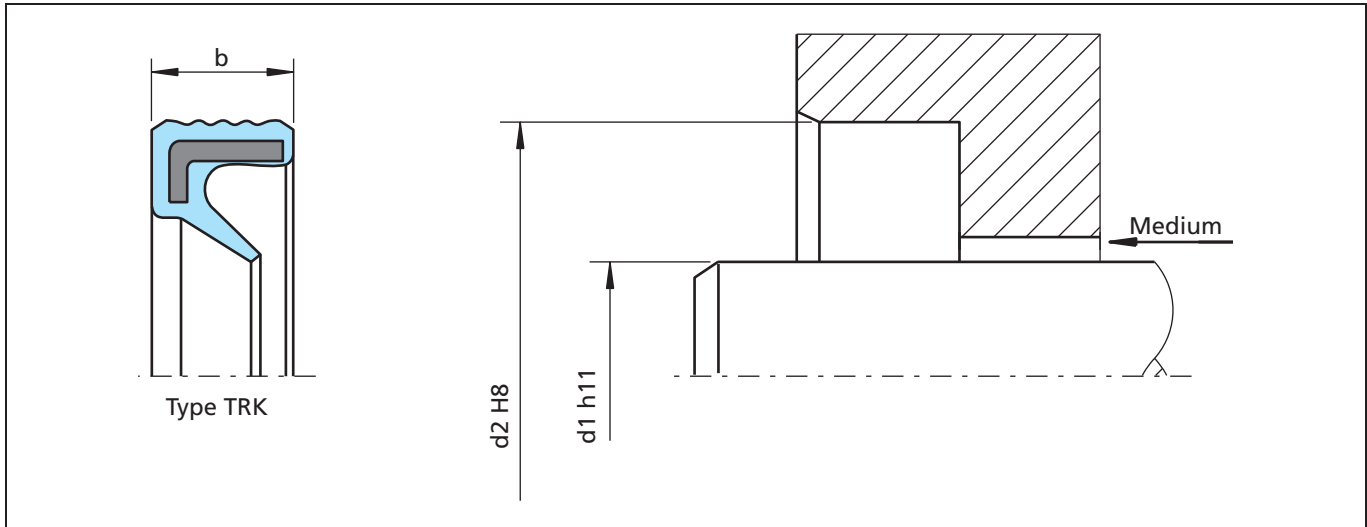

Figure 25 Installation drawing

General description

The Trelleborg Sealing Solutions type TRK are specially designed radial oil seals reinforced with a metal insert but without spring energized sealing lip and a wavy rubber covered outer diameter. STEFA CD type are available with flat rubber covered O.D. These types are not recommended for use in heavily polluted environments.

Advantages

- Good static sealing and thermal expansion compensation
- Low friction and low heat generation
- Extremely compact design
- Low radial force provides a low break-out torque
- Suitable for scraper applications

Application examples

- Roller bearings
- Tooling fixtures (e.g. drilling machines)
- Sealing against viscous media (e.g. grease)
- Supplementary excluders (shaft ends)
- Axle King Pin seals

Technical data

Pressure:	Without pressure
Temperature:	-40°C to +200°C (depending on material)
Speed:	up to 10 m/s
Media:	mineral and synthetic base greases

Trelleborg Sealing Solutions has carried out several thousands compatibility tests. Please ask for details.

Important Note:

The above data are maximum values and cannot be used at the same time, e. g. the maximum operating speed depends on material type, pressure and temperature.



Table XXV Materials

Standard material*	TSS material code	Standard metal insert**
NBR (70 Shore A)	N7LM	Carbon steel
NBR (75 Shore A)	4N01	
FKM (70 Shore A)	VCBM	Carbon steel
FKM (75 Shore A)	4V01	

* Special grades and other materials (ACM, EACM, EPDM, HNBR, VMQ) on request.

** Metal insert can be supplied in different materials on request.

Ordering example oil seal TSS type

TSS type: K
 Code: TRK
 Dimensions: Shaft diameter 17 mm
 Housing diameter 23 mm
 Width 3 mm
 Material: NBR
 Material Code: N7LM

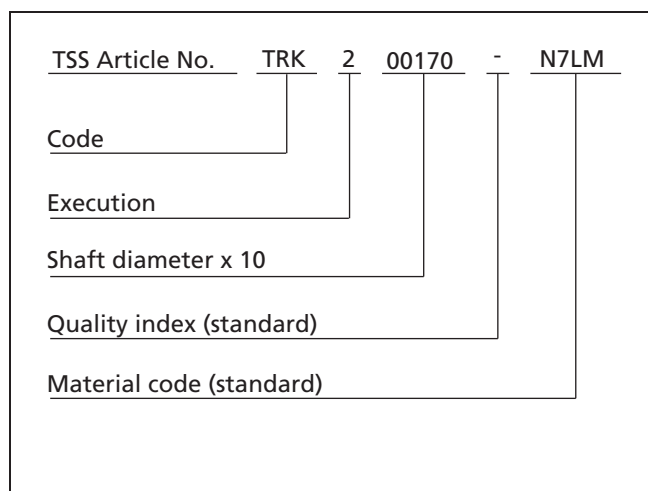

Table XXVI Preferred series / Dimension, TSS part numbers

Dimension			TSS Part No.	TSS	
d ₁	d ₂	b		NBR	FKM
4	8	2	TRK000040	X	
5	9	2	TRK000050	X	X
5	10	2	TRK100050	X	X
6	10	2	TRK000060		X
6	15	4	TRK200060	X	X
7	14	2	TRK100070	X	X
8	12	3	TRK000080	X	
8	15	3	TRK200080	X	X
9	13	3	TRK000090	X	
9	16	3	TRK200090	X	
10	14	3	TRK000100	X	X
10	16	4	TRK500100	X	
10	17	3	TRK100100	X	
10	19	3	TRK200100	X	
10	21	4	TRK300100	X	



Radial Oil Seal

Dimension			TSS Part No.	TSS	
d ₁	d ₂	b		NBR	FKM
10	26	4	TRK400100	X	
11	15	3	TRK000110	X	
12	16	3	TRK000120	X	
12	18	3	TRK100120	X	X
12	19	3	TRK200120	X	X
12	20	4	TRK300120	X	X
13	19	3	TRK000130	X	
14	20	3	TRK000140	X	X
15	21	3	TRK000150	X	X
15	23	3	TRK100150	X	
16	22	3	TRK000160	X	X
16	24	3	TRK200160	X	
17	23	3	TRK000170	X	
17	23.5	3.4	TRK200170	X	
17	25	3	TRK100170	X	
18	24	3	TRK000180	X	
18	24	4	TRK100180	X	
19	26	4	TRK100190	X	
19	27	4	TRK000190	X	
20	26	3	TRK000200	X	X
20	26	4	TRK100200	X	
20	28	4	TRK200200	X	X
22	28	4	TRK000220	X	
22	30	4	TRK100220	X	X
24	32	4	TRK000240	X	
25	32	4	TRK000250	X	
25	33	4	TRK100250	X	
25	35	4	TRK200250	X	X
26	34	4	TRK000260	X	
28	35	4	TRK000280	X	
28	38	6.5	TRK200280	X	
28	40	6.5	TRK300280	X	
30	37	4	TRK000300	X	X
30	40	4	TRK100300	X	X
30	40	6.5	TRK300300	X	
32	42	4	TRK000320	X	

Radial Oil Seal



Dimension			TSS Part No.	TSS	
d ₁	d ₂	b		NBR	FKM
32	45	6.5	TRK200320	X	
33	40	3	TRK100330	X	
33	40	4	TRK000330	X	
35	41	4	TRK000350	X	X
35	42	4	TRK100350	X	
35	45	4	TRK200350	X	
38	48	4	TRK000380	X	
40	47	4	TRK000400	X	
40	50	4	TRK200400	X	
40	56	8.5	TRK400400	X	
42	52	4	TRK000420	X	
45	52	4	TRK000450	X	
45	55	4	TRK100450	X	
45	62	8	TRKB00450	X	
48	58	4	TRK000480	X	
50	58	4	TRK000500	X	X
50	60	6	TRK100500	X	
50	62	5	TRK200500	X	
50	68	8.5	TRK300500	X	
55	63	5	TRK000550	X	
55	73	8.5	TRK100550	X	
60	72	4	TRK000600	X	
70	78	5	TRK000700	X	X
75	95	7	TRK000750	X	



Radial Oil Seal

■ Trelleborg Sealing Solutions type TRG

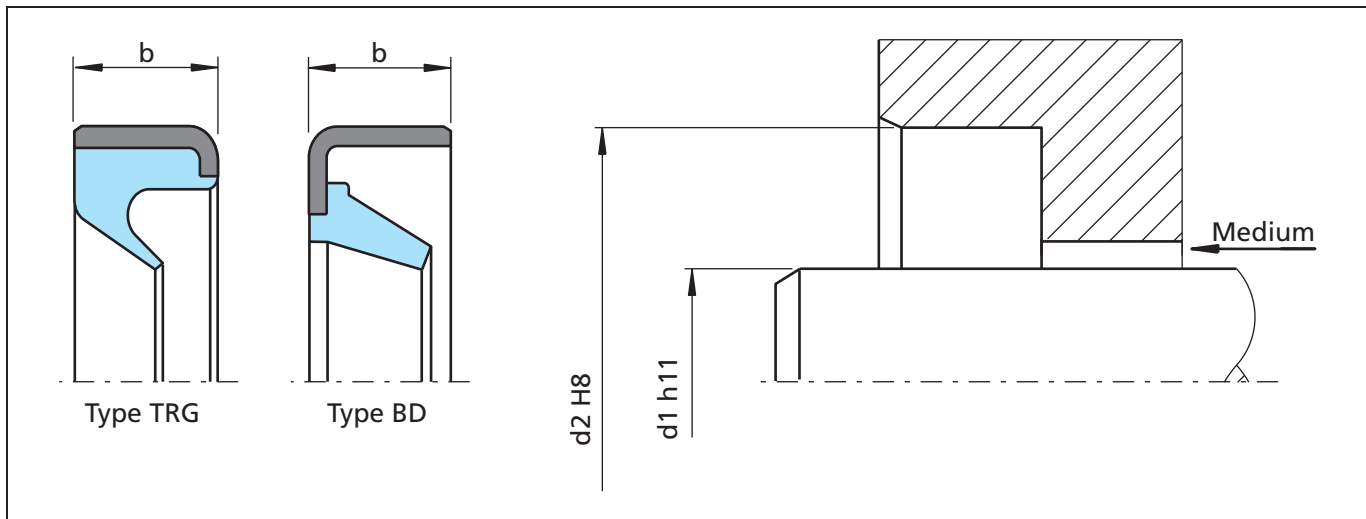

Figure 26 Installation drawing

General description

The Trelleborg Sealing Solutions type TRG and STEFA type BD are special metal cased radial oil seals without spring energized sealing lip. These types are not recommended for use in heavily polluted environments. As the static sealing between housing and metallic shell is limited, low viscosity media can "creep". Better performance can be achieved with Epoxy based resin O.D. coating. This special treatment is on request.

Advantages

- Good radial stiffness
- Good fitting stability avoiding pop-out of the seal
- Low friction and low heat generation
- Extremely compact design
- Low radial force provides a low break-out torque
- Suitable for scraper applications

Application examples

- Roller bearings
- Tooling fixtures (e.g. drilling machines)
- Sealing against viscous media (e.g. grease)
- Supplementary excluders (shaft ends)
- Axle King Pin seals

Technical data

Pressure:	without pressure
Temperature:	-40°C to +200°C (depending on material)
Speed:	up to 10 m/s
Media:	mineral and synthetic base greases

Trelleborg Sealing Solutions has carried out several thousands compatibility tests. Please ask for details.

Important Note:

The above data are maximum values and cannot be used at the same time, e. g. the maximum operating speed depends on material type, pressure and temperature.



Table XXVII Materials

Standard material*	TSS material code	STEFA material reference	Standard metal insert**
NBR (70 Shore A)	N7LM	-	Carbon steel
NBR (75 Shore A)	4N01	1452	
FKM (75 Shore A)	VCBM	-	Carbon steel
FKM (75 Shore A)	4V01	5466	

* Special grades and other materials (ACM, EACM, EPDM, HNBR, VMQ) on request.

** Metal insert can be supplied in different materials on request.

Ordering example oil seal TSS type

TSS type: G
 Code: TRG
 Dimensions: Shaft diameter 70 mm
 Housing diameter 78 mm
 Width 5 mm
 Material: NBR
 Material Code: N7LM

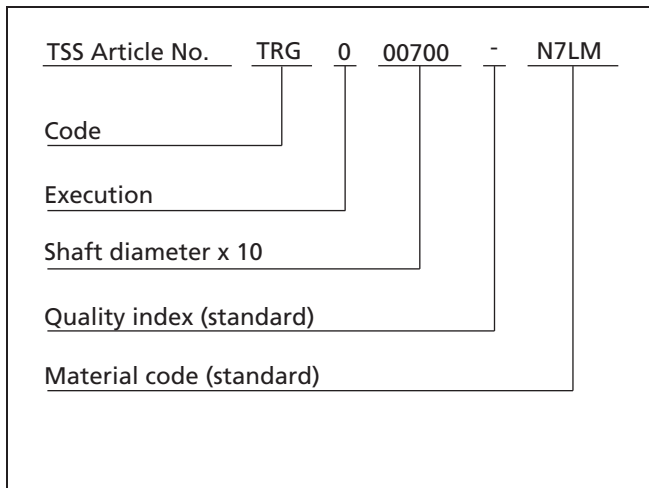

Ordering example oil seal STEFA type

STEFA type: BD
 Code: TRG
 Dimensions: Shaft diameter 70 mm
 Housing diameter 78 mm
 Width 5 mm
 Material: NBR 1452
 Material Code: 4N01

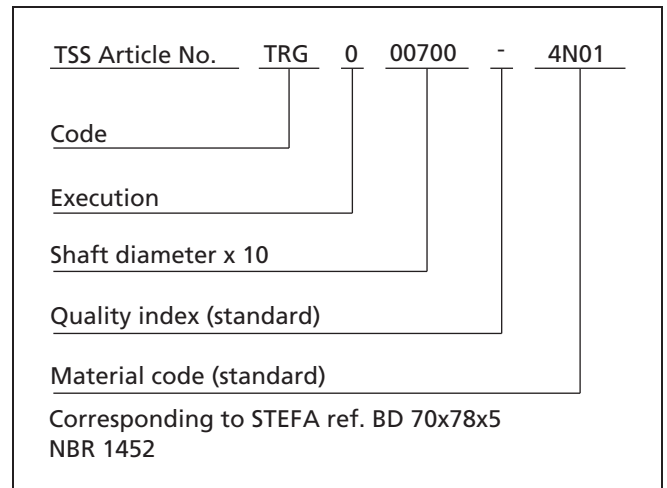

Table XXVIII Preferred series / Dimension, TSS part numbers

Dimension			TSS Part No.	STEFA			TSS	
d ₁	d ₂	b		Type	NBR 4N01	FKM 4V01	NBR N7LM	FKM VCBM
3	8	2	TRG000030				X	
4	8	2	TRG000040				X	X
5	9	2	TRG000050				X	
6	10	2	TRG000060				X	X
6	12	2	TRG100060				X	
7	11	2	TRG000070				X	X

() values in brackets are inch sizes.



Radial Oil Seal

Dimension			TSS Part No.	STEFA			TSS	
d ₁	d ₂	b		Type	NBR 4N01	FKM 4V01	NBR N7LM	FKM VCBM
8	14	2	TRG100080				X	
8	15	3	TRG200080				X	
9	13	3	TRG000090				X	
10	14	3	TRG000100				X	
10	15	3	TRG200100	BD	X			
10	16	4	TRG300100	BD	X	X		
10	17	3	TRG100100				X	
12	16	3	TRG000120				X	X
12	18	3	TRG100120				X	X
12	19	3	TRG200120				X	
14	22	3	TRG200140				X	
15	21	3	TRG000150				X	
15	23	3	TRG100150				X	
16	24	3	TRG200160				X	
17	23	3	TRG000170				X	
18	24	3	TRG000180				X	X
20	26	4	TRG100200				X	
20	28	4	TRG200200				X	X
21	29	4	TRG000210				X	
22	28	4	TRG000220				X	
24	32	4	TRG000240				X	
25	32	4	TRG000250	BD		X	X	X
25	32	5	TRG300250	BD	X			
25	33	4	TRG100250				X	
25	35	4	TRG200250				X	
27	40	10	TRG000270	BD	X			
28	35	6	TRG300280				X	
28	37	4	TRG100280				X	
30	37	4	TRG000300				X	
30	40	4	TRG100300				X	
35	42	4	TRG000350				X	X
35	42	4.46	TRG300350	BD		X		
36	42	4	TRG000360				X	
37	47	4	TRG000370				X	
37	48	4	TRG100370				X	
38	48	4	TRG000380				X	

() values in brackets are inch sizes.

Radial Oil Seal



Dimension			TSS Part No.	STEFA			TSS	
d ₁	d ₂	b		Type	NBR 4N01	FKM 4V01	NBR N7LM	FKM VCBM
38.1	47.1	6.4	TRG000381	BD	X			
39.69 (1.56")	52.48 (2.07")	4.80 (0.19")	TRG000396	BD	X			
40	47	4	TRG000400				X	
40	48	4	TRG100400				X	
40	50	4	TRG200400				X	
40	52	5	TRG300400				X	
40	62	4.76	TRG400400	BD	X			
42	52	4	TRG000420				X	
43	53	4	TRG000430				X	
44	54	5	TRG000440	BD	X			
45	52	4	TRG000450				X	
45	55	4	TRG100450				X	X
50	58	4	TRG000500				X	
52	68	6	TRG000520	BD	X			
55	63	5	TRG000550				X	X
61.6	74	5	TRG000616	BD	X			
67	75.5	4.3	TRG000670	BD	X			
70	78	5	TRG000700	BD	X		X	
77	85.5	4.8	TRG000770	BD	X			

() values in brackets are inch sizes.



■ Rotary and axial seal combination

General Description

In many applications rotary shaft lip seals are used to seal against various media.

Lip seals often fail because of the destruction of the lubricant film, resulting in rapid wear, due to the ingress of dirt, dust, moisture etc. The use of shaft seals with one or more auxiliary sealing lips (dust lips) provides a limited improvement, but it is not always sufficient. In order to meet the constantly increasing sealing requirements, especially for the environmental protection and long service life the Trelleborg Sealing Solutions COMBI-seal is a simple solution. It has proved to be particularly well suited even in critical applications with heavy contamination. The COMBI-seal consists of a GAMMA seal and a rotary shaft lip seal working together. The lip seal provides the counterface for the GAMMA seal which is fixed to the shaft by press fit. See Figure 27 and 28.

Years of successful experiences show that another frequently used alternative consists in the combination of a V-Ring seal with a standard seal selected inside the type list: TRC; TRD; TRB; TRF.

The rotary shaft seal should be ordered **“Without Markings”** on the air side.

Radial Oil Seal + GAMMA seal

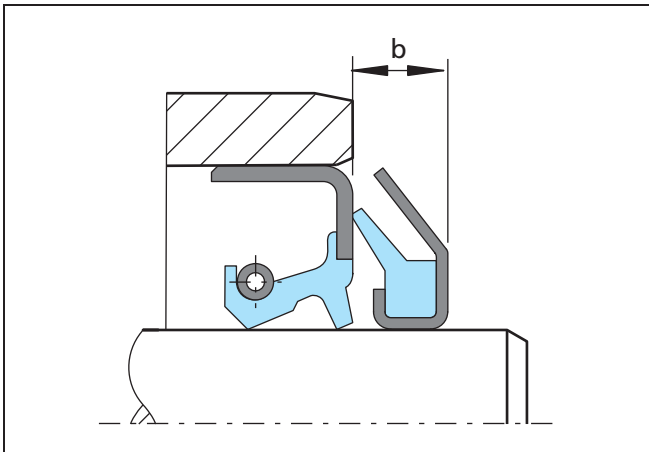

Figure 27 GAMMA seal fitted on the shaft end

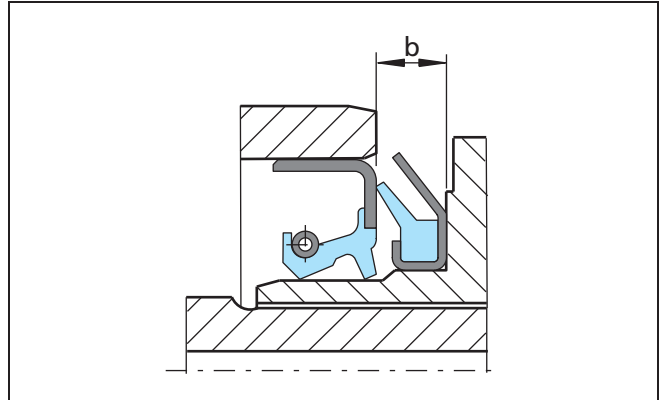

Figure 28 GAMMA seal fitted on the shaft boss

Radial Oil Seal + V-Ring

The function of the rotary axial seal is to prevent by centrifugation the intrusion of particles and water drops.

In other words, it adds its original protection capacity to the radial seal functionality. Sufficient space is required on the shaft to host the axial seal width. (See Figure 29).

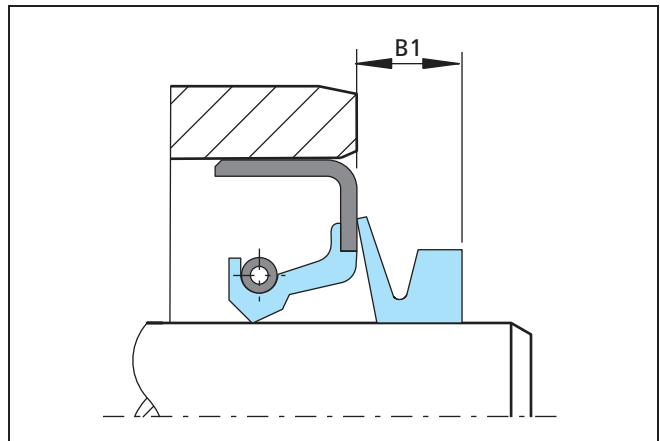

Figure 29 V-Ring fitted on the shaft end

Housing and shaft design

The radial lip seal needs to be assembled in the housing according to usual fitting instructions. Both V-Ring and GAMMA seal is assembled later on the shaft. The shaft design requires to be adapted by an elongation corresponding at least to B1 (b) dimension. In case of very high peripheral speeds, the V-Ring body should be radially supported. See also the instructions reported in the specific catalog chapter.



The GAMMA seal can be fitted according above sequence but sometimes the shaft surface must be slightly changed in order to avoid scratches at assembly that can negatively influence the radial seal functionality (See Figure 27 and 28). See also the instructions in specific catalog chapters.

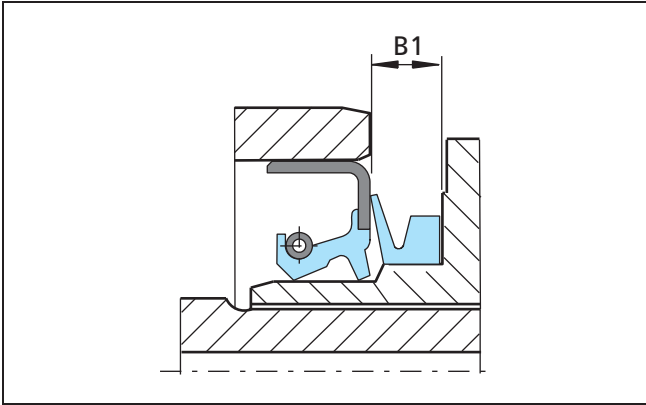

Figure 30 V-Ring type A fitted on the shaft boss

In the examples the V-Ring “type A” is represented, but any other type of V-Ring is usable in accordance with space available and application requirements.

In special application conditions, with design alterations in the housing, it is also possible the use of TRB type (labyrinth formed by metal shell and housing).



Radial Oil Seal

■ Product description

The combination of Radial shaft seal with V-Ring or GAMMA seals is recommended for use in heavily polluted environments.

Both the radial shaft seal and the GAMMA seal housing may also be manufactured with different metal shell as well as different rubber types for sealing elements. See specific paragraphs.

Advantages

- Longer service life and high function reliability
- Good IP protection for electrical motors (VDE-Norm 0470-1)
- Good protection against water splash and welding sparks
- Simple handling
- Superior total economy
- Friction loss decreases with increasing shaft speed

Application examples

Typical applications are all equipment working in contaminated environments where dust, foreign matter and liquid splatter are present.

Some examples:

- gear motors
- journal and gear transmissions
- bearing housings
- power saws
- utility vehicles
- agricultural machinery and equipment
- wheel hubs
- propeller shafts
- pumps
- hydraulic motors
- tool machinery
- equipment for steel manufacturing
- metal working machinery

Technical data

Pressure:	see radial seal data
Temperature:	-40 °C to +200 °C (depending on material)
Speed:	up to 20 m/s (depending on material)
Mediums:	Mineral and synthetic oils (CLP, HLP, APGL etc.)

Trelleborg Sealing Solutions has carried out several thousands compatibility tests. Please ask for details.

Important Note:

The above data are maximum values and cannot be used at the same time, e. g. the maximum operating speed depends on material type, pressure and temperature.

Materials

See specific chapters.

Ordering example

Order components separately as per specific chapters. Order the radial oil seals "**without marking**".



■ Combined rotary shaft seal

General description

The combined rotary shaft lip seal is an assembly which includes a supplementary protection of the radial sealing elements with an axial rotary sealing lip integrated into a wear sleeve. The rubberized wear sleeve and radial seal are designed to satisfy both customer's and DIN 3760 (3761) specifications.

Sealing lips design

The sealing lip's design corresponds to the latest state of development based on many years of laboratory and field tests. The main radial sealing edge can either be ready molded (when equipped with TURBO ribs) or trimmed by mechanical cutting. The total radial force of the sealing lip is extremely low thanks to the miniaturization of the lip profile and the application of smallest possible Garter spring. The above miniaturization is made in order to reduce as much as possible the metal sleeve wear, the friction loss and relevant heat generation.

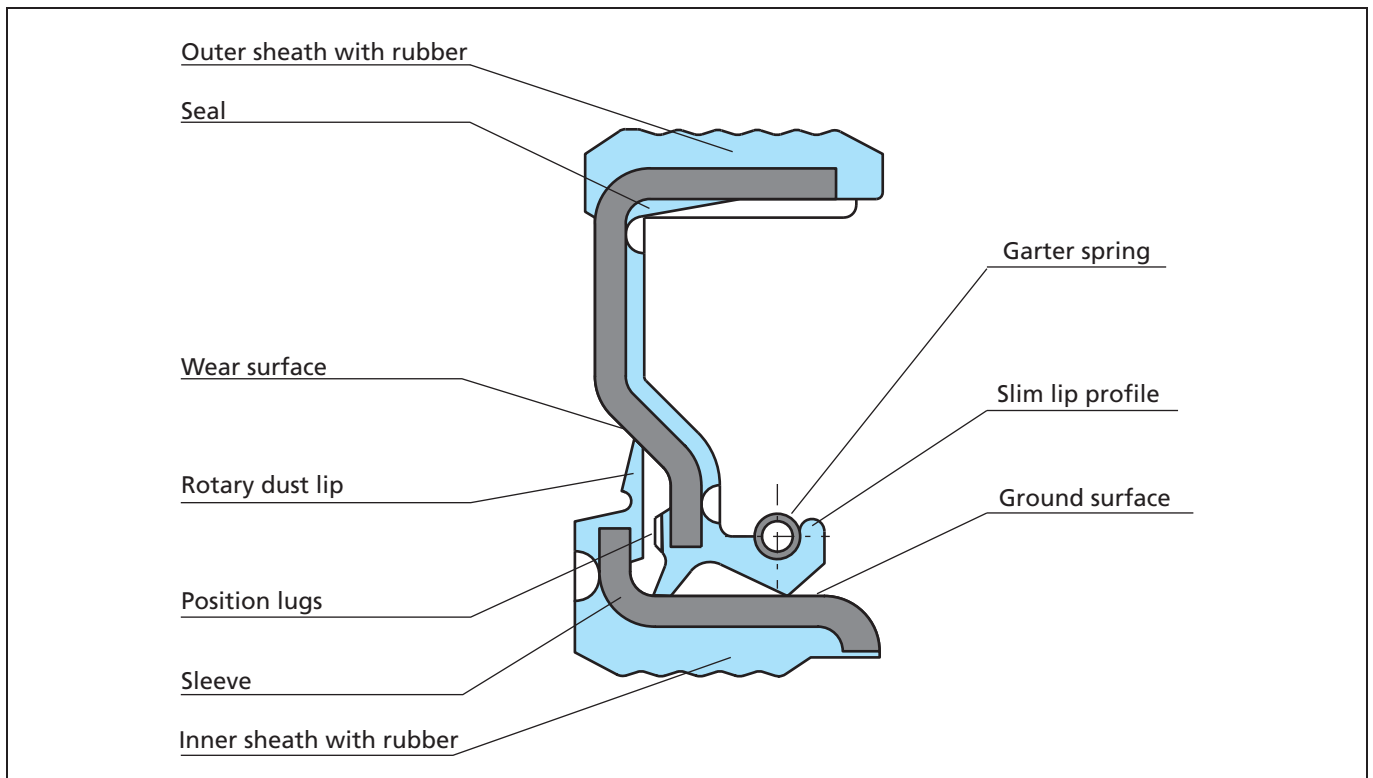

Figure 31 APJ seal details



■ STEFA standard APJ type

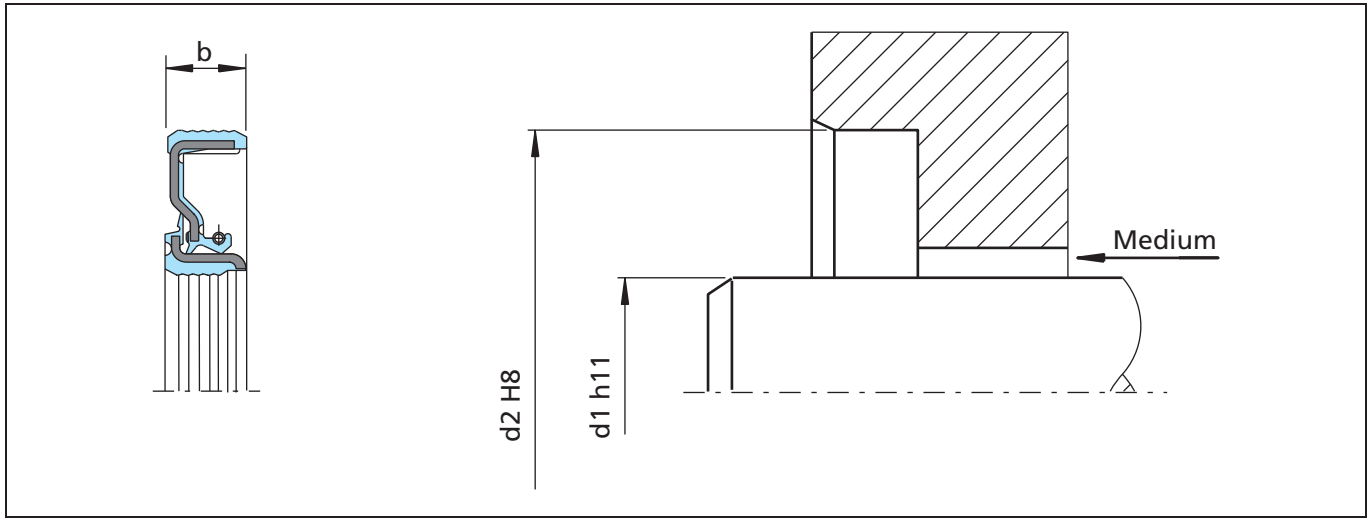

Figure 32 Installation drawing

Product description

STEFA standard APJ is a seal with completely rubber covered outer diameter. Two different O.D designs are available: Flat rubber sheath as well as wavy, both correctly fitting into H8 bores.

APJ seal is recommended for use in heavily polluted environments.

Both the seal and the sleeve may also be manufactured with different metal insert material as well as different rubber types.

Advantages

- Good static sealing
- Compensation of different thermal expansion
- No risk of fretting corrosion
- Higher bore surface roughness is allowed
- Do not require shaft hardening
- Do not require shaft grinding
- Modern lip design provides low power loss

Application examples

- Transmission systems (e.g. gearboxes)
- Pumps
- Washing machines
- Machinery for Industry (e.g. tool machines)
- Axles for heavy-duty applications

Technical data

Pressure:	up to 0.05 MPa
Temperature:	-40 °C to +200 °C (depending on material)
Speed:	up to 10 m/s (depending on material)
Media:	mineral and synthetic oils (CLP, HLP, APGL etc.)

Trelleborg Sealing Solutions has carried out several thousands compatibility tests. Please ask for details.

Important Note:

The above data are maximum values and cannot be used at the same time, e. g. the maximum operating speed depends on material type, pressure and temperature.



Table XIX Materials

Standard material*	TSS material code	Standard metal insert**	Standard spring**
NBR (75 Shore A)	4N011	Carbon steel	Carbon steel
FKM (75 Shore A)	4V012	Carbon steel	Stainless steel

* Special grades and other materials (ACM, EACM, EPDM, HNBR, VMQ) on request.

** Metal insert, and spring as well, can be supplied in different materials on request.

Remark: These seals are customer tailored products.

For more details please contact your local Trelleborg Sealing Solutions marketing company.



Radial Oil Seal

■ STEFA 1B/APJ and 2B/APJ types - housing as per DIN 3760-3761

The design of the radial seal corresponds to STEFA Type 1B/CC and 2B/CC.

The sleeve remains the same for all kind of radial seal design.

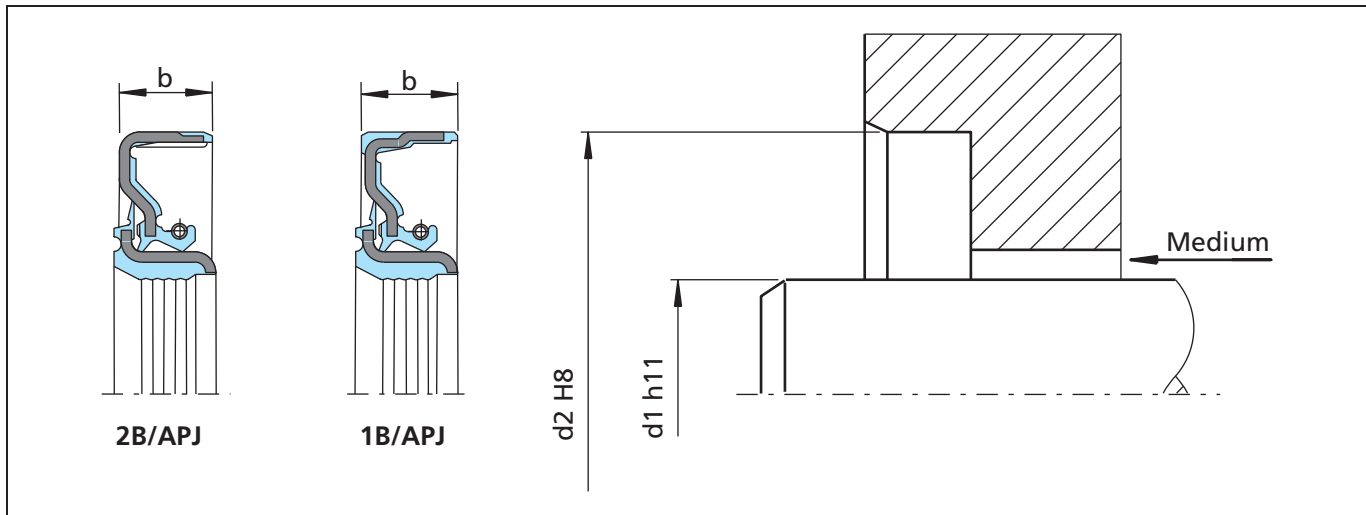

Figure 33 Installation drawing

Product description

STEFA 1B/APJ and 2B/APJ types are radial lip seals with partially rubber covered outer diameter.

1B/APJ type recommended for use in heavily polluted environments and where a good axial retention force is required with a good heat transfer as well. The type 2B/APJ is recommended for aluminum or soft metal housings that may be scratched at assembly by metal frame of the seal.

Advantages

- Good static sealing
- Compensation of different thermal expansion
- Higher bore surface roughness is allowed
- Do not require shaft treatment (hardening and grinding)
- Modern lip design provides low power loss
- Good heat transfer to outside
- Quick servicing (No shaft rework required)

Applications examples

- Transmission systems (e.g. gearboxes)
- Pumps
- Machinery industry (e.g. Machine tools, weaving machinery)
- Axle Hubs and axles for heavy-duty applications

Technical data

Pressure:	up to 0.05 MPa
Temperature:	-40°C to +200°C (depending on material)
Speed:	up to 10 m/s (depending on material)
Media:	mineral and synthetic oils (CLP, HLP, APGL etc.)

Trelleborg Sealing Solutions has carried out several thousands compatibility tests. Please ask for details.

Important Note:

The above data are maximum values and cannot be used at the same time, e. g. the maximum operating speed depends on material type, pressure and temperature.



Table XXX Materials

Standard material*	TSS material code	Standard metal insert**	Standard spring**
NBR (75 Shore A)	4N011	Carbon steel	Carbon steel
FKM (75 Shore A)	4V012	Carbon steel	Stainless steel

* Special grades and other materials (ACM, EACM, EPDM, HNBR, VMQ) on request.

** Metal insert, and spring as well, can be supplied in different materials on request.

Remark: These seals are customer tailored products.

For more details please contact your local Trelleborg Sealing Solutions marketing company.



■ Trelleborg Sealing Solutions type TRJ/TRL

Fiber reinforced oil seals for large diameter

Fiber reinforced oil seals contain no metal parts with the exception of the spring. Instead of the metal insert, a reinforced fiber component is molded into the body of the seal. Damage through transport and mounting is consequently excluded.

Fiber reinforced oil seals are mainly used for installation in constructions and equipment with large diameters.

The use of an axial retaining plate is necessary except for the type TRJ/F and respectively for the type TRL/F.

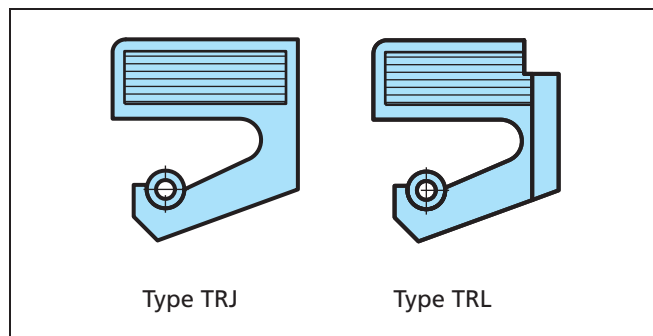

Figure 34 Fibers reinforced design for large diameters

Split version

To ease the mounting or in case of repair the types TRJ and TRL are also available in split version.

To ensure effective sealing at the split ends, a full rubber section is molded at the join so that contact between homogeneous elastic surfaces maximizes the sealing effect.

The interface should always be above the oil level.

If two seals in split version are mounted together, the interface should be turned a minimum of 30° to the side.

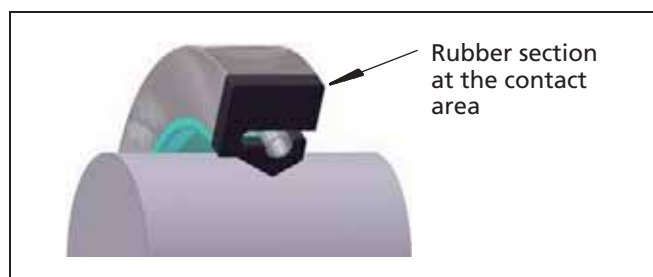

Figure 35 Contact area, split seal

Separation of two media with type TRL

A single oil seal should not be used for the separation of two Media.

In such cases two seals are fitted in a back to back arrangement. The type TRL is suitable for the sealing of large diameters. It is a special design with peripheral and radial grooves where a lubricant could be applied.

The peripheral groove on the seal reduces the need to cut a groove in the housing. See figure : Type TRL mounted back to back.

The seal can used for:

- Isolation of two media
- If a lubrication is necessary from the outside

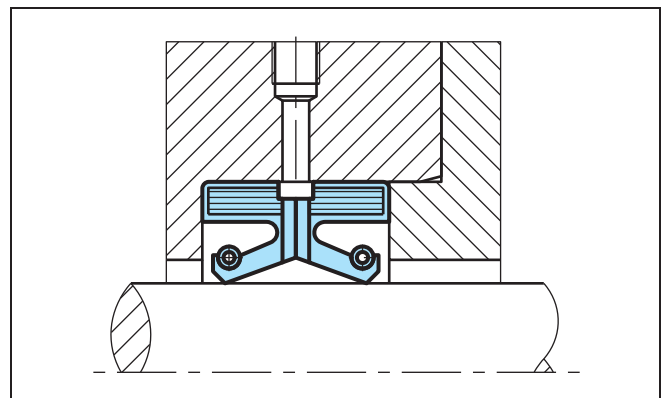

Figure 36 Type TRL mounted back to back

Special design TRJ/F and TRL/F with reinforced shoulder

Whenever a retaining plate cannot be fitted we can supply a seal made in a special hardened compound namely type TRJ/F and TRL/L, which makes the seal self-retaining and providing effective sealing also at the O.D.

Trelleborg Sealing Solutions type TRJ/F and TRL/F are supplied in standard form and are not available in split version. See figure 37.

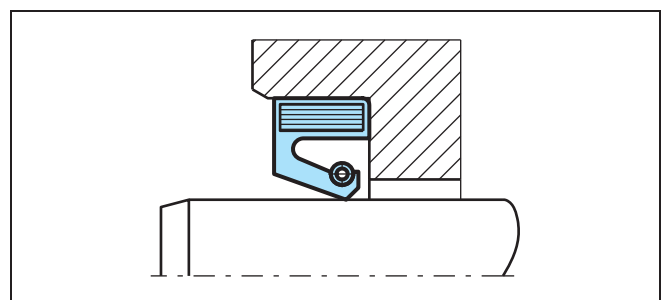

Figure 37 Type TRJ/F mounted without axial retaining plate



Design Instructions

Installation on the shaft

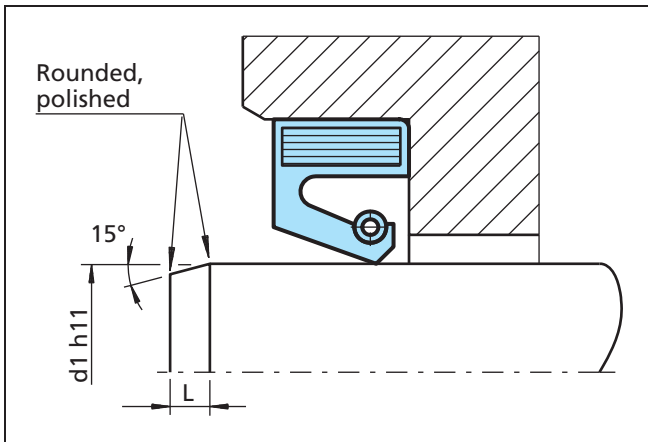

Figure 38 Installation of the oil seal

To facilitate the installation of the seal with minimum risk of lip damage, the shaft have a 15° chamfer with length "L" as function of its diameter "d1".

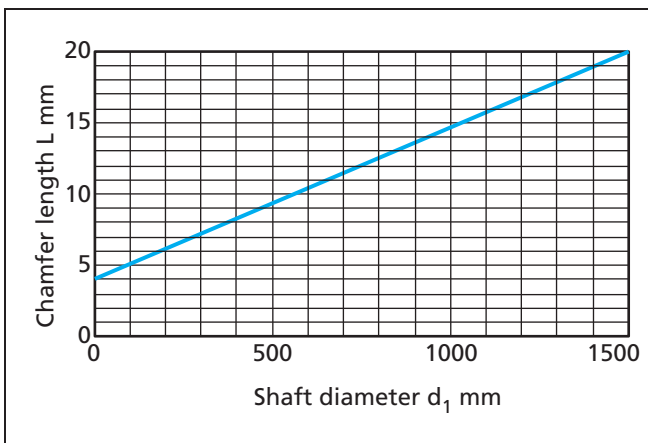

Figure 39 Chamfer length as function of the shaft diameter

Eccentricity

Eccentricity between shaft and housing bore centers should be avoided in order to eliminate unilateral load of the lip.

Table XXXI Static Eccentricity

d_1	$b \times f$ (mm)	max. stat. Ecc. (mm)
100 - 250	16 x 20	0.50
250 - 400	20 x 22	0.55
400 - 600	22 x 25	0.62
>600	25 x 32	0.70

Shaft run out

Shaft run out should be avoided or kept within a minimum. At higher speeds there is a risk that the inertia of the sealing lip prevents it from following the shaft movement. The seal must be located next to the bearing and the bearing play be maintained at the minimum value possible.

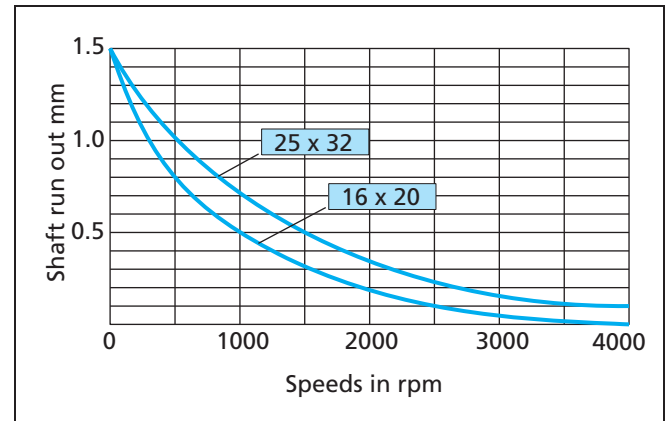

Figure 40 Shaft run out

Installation in the gland

The static seal in the mounting bore is provided by the corresponding force fit allowance at the outer sheath of the seal.

The bore tolerance is specified to DIN ISO 286T2-H8.

Values for the surface roughness in the gland are specified in ISO 6194/1.

General values:	Ra	= 1.6 - 6.3 μm
	Rz	= 10 - 20 μm
	Rmax.	= 16 - 25 μm

For gas sealing, a good score-free and spiral-free surface finish is necessary. If the rotary shaft lip seal is bonded into the housing, ensure that no adhesive comes into contact with the sealing lip or the shaft.

The bore d_2 of the sealing housing indicated in table XXXI as function of shaft diameter. ($d_2 = d_1 + 2 \times f$). See page 116.

The width (b) including the tolerance is also given in table XXXII.



Radial Oil Seal

■ Installation, Type TRJ

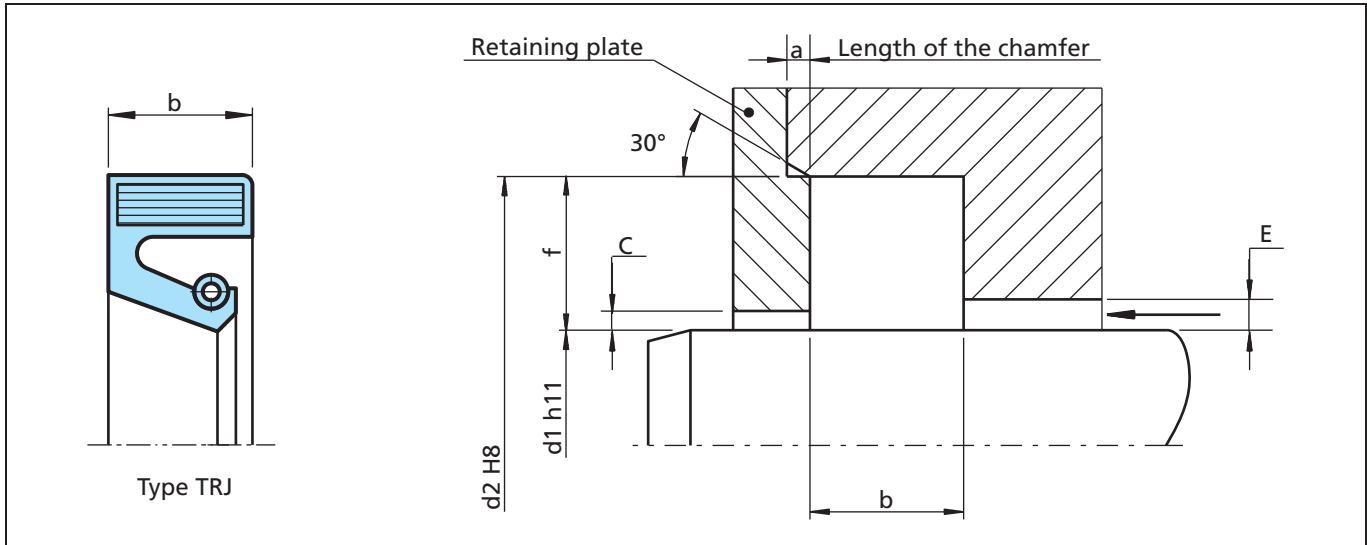

Figure 41 Installation drawing

■ Installation, Type TRL

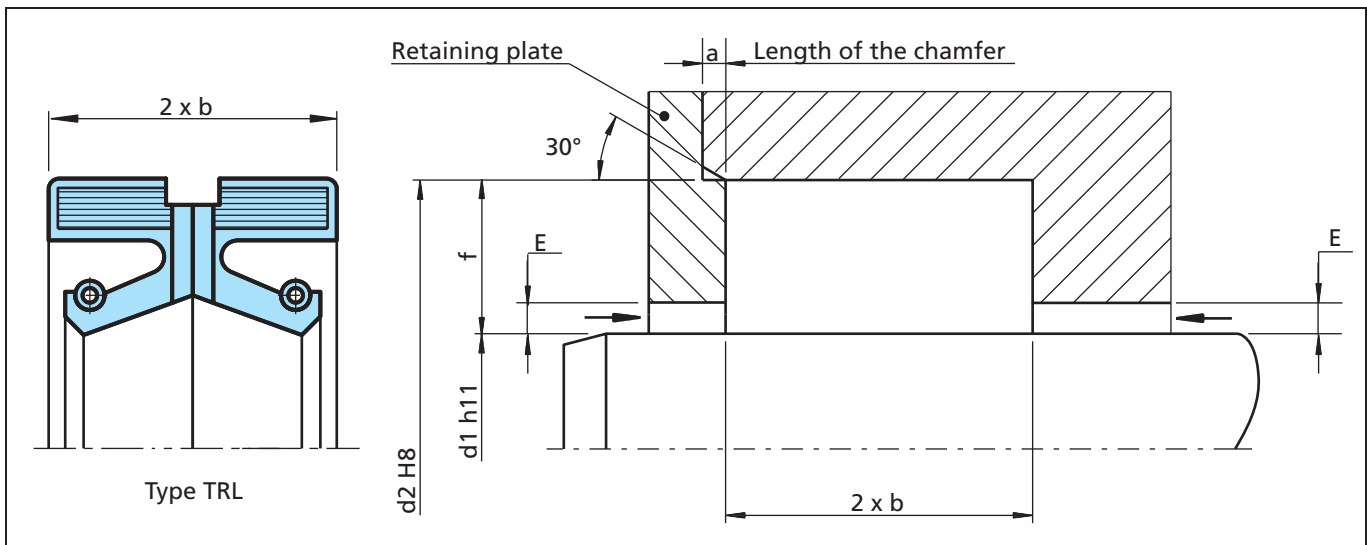

Figure 42 Installation drawing

Table XXXII Dimensions

d1	b x f	a	E	C	b
100 - 250	16 x 20	2.0	9	4	16 ±0.1
250 - 400	20 x 22	2.2	11	6	20 ±0.2
400 - 600	22 x 25	2.5	11	7	22 ±0.2
>600	25 x 32	3.2	14	8	25 ±0.2



■ Technical Data, Type TRJ and TRL*

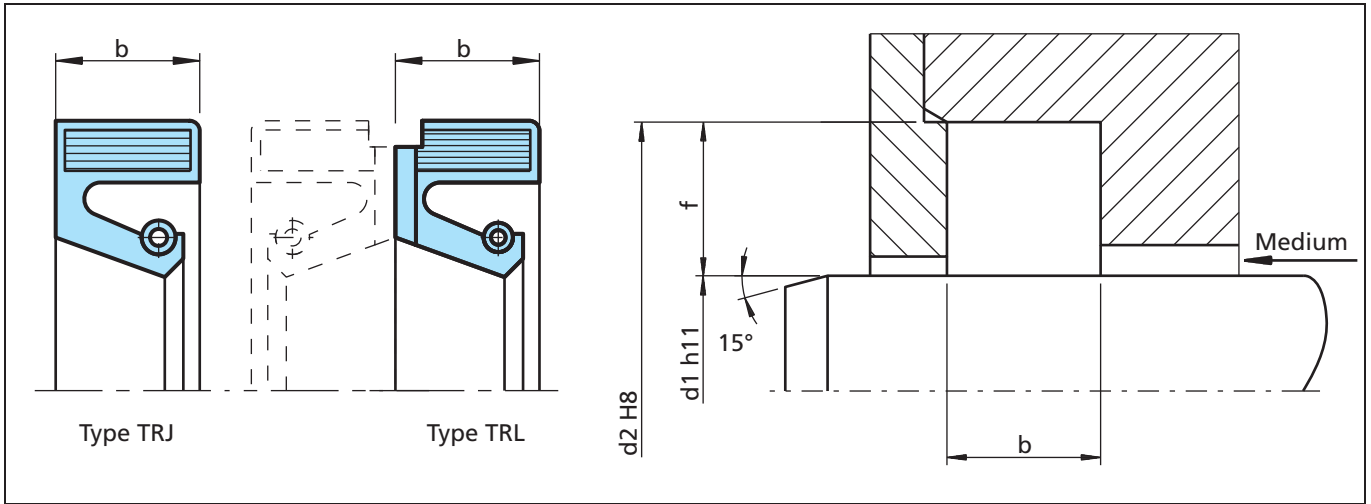

Figure 43 Installation drawing

Table XXXIII Material

Standard-material*	TSS Material code	Standard-spring*
NBR (75 Shore A)	4NC01	Carbon steel
HNBR (75 Shore A)	4HC01	Carbon steel
FKM (75 Shore A)	4VC02	Stainless steel

* The spring can be supplied in different materials on request.

Table XXXIV Technical Data

Type	Temperature	Speed	Pressure	Dimensions
TRJ	-30°C to +200°C	up to 25 m/s	0.05 MPa	100 - 1890
TRL	-30°C to +200°C	up to 25 m/s	0.05 MPa	100 - 1890

Ordering example

TSS Code: TRJ
 Dimensions: Shaft diameter: 100 mm
 Housing diameter: 115 mm
 Width: 8.9 mm
 Material: NBR
 Material-Code: 4NC01

TSS Article No.	TRJ	100x115x8,9	4NC01
TSS Code			
Dimension			
Material			



Radial Oil Seal

Table XXXV Dimensions for Type TRJ/TRL

Dimensions				Type	
d ₁	d ₂	b	f	TRJ	TRL
100.0	115.0	8.9	7.5	X	○
100.0	115.0	9.0	7.5	X	○
100.0	120.0	13.0	10.0	X	○
100.0	125.0	13.0	12.5	X	○
100.0	125.0	15.0	12.5	X	○
100.0	125.4	12.7	12.7	X	X
100.0	130.0	12.0	15.0	X	○
100.0	130.0	15.0	15.0	X	○
100.0	132.0	12.5	16.0	X	X
100.0	140.0	16.0	20.0	X	○
105.0	129.0	13.0	12.0	X	○
105.0	130.0	12.0	12.5	X	○
105.0	130.0	13.0	12.5	X	○
105.0	133.5	12.7	14.3	X	○
105.0	137.0	16.0	16.0	X	○
105.0	140.0	12.0	17.5	X	○
105.0	143.0	16.0	19.0	X	○
105.0	145.0	16.0	20.0	X	○
110.0	126.0	9.0	8.0	X	○
110.0	126.0	12.0	8.0	X	○
110.0	130.0	9.0	10.0	X	○
110.0	130.0	12.0	10.0	X	○
110.0	130.0	13.0	10.0	X	○
110.0	135.0	12.0	12.5	X	○
110.0	140.0	12.0	15.0	X	○
110.0	140.0	14.0	15.0	X	○
110.0	140.0	15.0	15.0	X	○
110.0	140.0	16.0	15.0	X	○
110.0	141.0	13.7	15.5	X	○
110.0	145.0	19.0	17.5	X	○
110.0	150.0	16.0	20.0	X	○
115.0	137.0	8.8	11.0	X	○
115.0	137.0	9.0	11.0		X
115.0	140.0	12.0	12.5	X	○
115.0	140.0	13.0	12.5	X	X
115.0	140.4	9.5	12.7	X	○
115.0	145.0	12.0	15.0	X	○
115.0	145.0	15.0	15.0	X	○
115.0	150.0	15.0	17.5	X	○

Dimensions				Type	
d ₁	d ₂	b	f	TRJ	TRL
115.0	155.0	16.0	20.0	X	○
118.0	140.0	14.0	11.0	X	○
120.0	140.0	12.5	10.0	X	○
120.0	140.0	13.0	10.0	X	○
120.0	140.0	14.5	10.0	X	○
120.0	144.0	15.5	12.0	X	○
120.0	145.0	15.5	12.5	X	○
120.0	150.0	13.0	15.0	X	○
120.0	150.0	15.0	15.0	X	○
120.0	150.0	16.0	15.0	X	○
120.0	152.0	16.0	16.0	X	○
120.0	160.0	12.0	20.0	X	○
120.0	160.0	16.0	20.0	X	X
120.0	170.0	15.0	25.0	X	○
125.0	140.0	10.0	7.5	X	○
125.0	150.0	12.0	12.5	X	○
125.0	150.0	15.0	12.5	X	○
125.0	153.5	12.7	14.2	X	○
125.0	155.0	12.0	15.0	X	○
125.0	160.0	12.0	17.5	X	○
125.0	160.0	13.0	17.5	X	○
125.0	160.0	15.0	17.5	X	○
125.0	165.0	15.0	20.0	X	○
125.0	165.0	16.0	20.0	X	○
127.0	157.0	15.0	15.0	X	○
128.0	165.0	15.0	18.5	X	○
130.0	150.0	10.0	10.0	X	○
130.0	150.0	12.0	10.0	X	○
130.0	155.0	10.0	12.5	X	○
130.0	155.0	15.5	12.5	X	○
130.0	160.0	12.0	15.0	X	○
130.0	160.0	15.0	15.0	X	○
130.0	160.0	16.0	15.0	X	○
130.0	165.0	13.0	17.5	X	○
130.0	170.0	13.0	20.0	X	○
130.0	170.0	16.0	20.0	X	○
133.0	165.0	12.5	16.0		X
134.0	169.0	15.0	17.5	X	○
135.0	157.0	8.0	11.0	X	○

"X" Tools available.

"○" As special part available on request.

Dimensions printed in **bold** are preferred sizes. Further sizes on request.

Radial Oil Seal



Dimensions				Type	
d ₁	d ₂	b	f	TRJ	TRL
135.0	160.0	12.0	12.5	X	○
135.0	165.0	13.0	15.0	X	○
135.0	167.0	15.0	16.0	X	○
135.0	170.0	12.0	17.5	X	○
135.0	170.0	13.0	17.5	X	○
135.0	170.0	16.5	17.5	X	○
135.0	175.0	16.0	20.0	X	○
136.0	160.0	10.0	12.0	X	○
138.0	180.0	15.0	21.0	X	○
139.0	155.0	10.0	8.0	X	○
139.0	169.0	14.6	15.0	X	○
140.0	155.0	10.0	7.5	X	○
140.0	160.0	13.0	10.0	X	○
140.0	165.0	15.0	12.5	X	○
140.0	168.0	21.0	14.0	X	○
140.0	170.0	15.0	15.0	X	○
140.0	180.0	12.0	20.0	X	○
140.0	180.0	15.0	20.0	X	○
140.0	180.0	16.0	20.0	X	X
140.0	190.0	15.0	25.0	X	○
143.0	165.0	10.0	11.0	X	○
144.0	180.0	15.0	18.0	X	○
145.0	170.0	13.0	12.5	X	○
145.0	170.0	15.0	12.5	X	○
145.0	180.0	12.0	17.5	X	○
145.0	180.0	14.0	17.5	X	○
149.0	179.0	13.0	15.0	X	○
149.0	180.0	16.0	15.5	X	○
150.0	172.0	12.7	11.0	X	○
150.0	180.0	12.0	15.0	X	X
150.0	180.0	13.0	15.0	X	○
150.0	180.0	14.0	15.0	X	○
150.0	180.0	15.0	15.0	X	○
150.0	185.0	15.0	17.5	X	○
150.0	188.0	16.0	19.0	X	○
150.0	190.0	16.0	20.0	X	X
150.0	190.0	20.0	20.0	X	○
152.0	180.0	14.0	14.0	X	○
152.0	190.0	19.0	19.0	X	○

Dimensions				Type	
d ₁	d ₂	b	f	TRJ	TRL
154.0	180.0	12.2	13.0	X	○
155.0	175.0	10.8	10.0	X	○
155.0	180.0	12.5	12.5	X	○
155.0	180.0	15.0	12.5	X	○
155.0	190.0	13.0	17.5	X	○
156.0	195.0	15.0	19.5		X
159.0	200.0	16.0	20.5	X	○
160.0	188.0	21.0	14.0	X	○
160.0	190.0	15.0	15.0	X	○
160.0	190.0	16.0	15.0	X	○
160.0	200.0	16.0	20.0	X	X
165.0	190.0	15.0	12.5	X	○
165.0	195.0	15.0	15.0	X	X
165.0	200.0	15.0	17.5	X	○
165.0	203.0	19.0	19.0	X	○
165.0	205.0	16.0	20.0	X	○
168.0	200.0	16.0	16.0	X	○
169.0	200.0	12.0	15.5	X	○
169.0	201.0	12.5	16.0	X	○
170.0	192.0	10.7	11.0	X	○
170.0	195.0	14.2	12.5	X	○
170.0	200.0	12.0	15.0	X	X
170.0	200.0	15.0	15.0	X	○
170.0	205.0	18.0	17.5	X	○
170.0	210.0	16.0	20.0	X	X
170.0	220.0	15.0	25.0	X	○
170.0	223.0	20.0	26.5	X	○
174.0	214.0	16.0	20.0	X	○
175.0	200.0	15.0	12.7	X	○
175.0	205.0	15.0	15.0	X	X
175.0	215.0	15.0	20.0	X	○
175.0	215.0	16.0	20.0	X	○
180.0	200.0	15.0	10.0	X	○
180.0	205.0	12.5	12.5	X	○
180.0	210.0	12.0	15.0	X	○
180.0	210.0	15.0	15.0	X	X
180.0	212.0	16.0	16.0	X	○
180.0	215.0	15.0	17.5	X	○
180.0	216.0	21.8	18.0	X	○

"X" Tools available.

"○" As special part available on request.

Dimensions printed in **bold** are preferred sizes. Further sizes on request.



Radial Oil Seal

Dimensions				Type	
d ₁	d ₂	b	f	TRJ	TRL
180.0	220.0	13.0	20.0	X	○
180.0	220.0	16.0	20.0	X	X
180.0	230.0	16.0	25.0	X	○
182.0	215.0	16.0	16.5	X	○
185.0	210.0	13.0	12.5	X	○
185.0	215.0	15.0	15.0		X
185.0	215.0	16.0	15.0	X	○
185.0	220.0	16.0	17.5	X	○
185.0	225.0	16.0	20.0	X	X
185.0	230.0	16.0	22.5	X	○
190.0	210.0	15.0	10.0	X	○
190.0	212.0	11.7	11.0	X	○
190.0	215.0	16.0	12.5	X	○
190.0	220.0	15.0	15.0	X	X
190.0	220.0	16.0	15.0	X	○
190.0	225.0	18.0	17.5	X	○
190.0	230.0	15.0	20.0	X	○
190.0	230.0	16.0	20.0	X	X
195.0	220.0	15.0	12.5	X	○
195.0	230.0	15.0	17.5	X	○
195.0	230.0	16.0	17.5	X	○
195.0	235.0	16.0	20.0	X	○
196.0	228.0	16.0	16.0	X	○
196.0	235.0	19.0	19.5	X	○
200.0	225.0	15.0	12.5	X	○
200.0	230.0	15.0	15.0	X	X
200.0	230.0	16.0	15.0	X	○
200.0	235.0	18.2	17.5	X	○
200.0	240.0	15.0	20.0	X	○
200.0	240.0	16.0	20.0	X	X
200.0	250.0	15.0	25.0	X	○
200.0	250.0	18.0	25.0	X	○
205.0	230.0	16.0	12.5	X	○
205.0	245.0	16.0	20.0	X	○
205.0	245.0	20.0	20.0	X	○
205.0	250.0	16.0	22.5	X	○
210.0	240.0	13.0	15.0	X	○
210.0	245.0	15.0	17.5	X	○
210.0	245.0	18.0	17.5	X	○

Dimensions				Type	
d ₁	d ₂	b	f	TRJ	TRL
210.0	246.0	16.0	18.0	X	○
210.0	250.0	15.0	20.0	X	○
210.0	250.0	16.0	20.0	X	X
210.0	274.0	26.0	32.0	X	○
213.0	248.0	16.0	17.5	X	○
215.0	240.0	12.0	12.5	X	○
215.0	245.0	16.0	15.0	X	X
215.0	247.0	12.5	16.0	X	○
215.0	248.0	15.0	16.5	X	○
215.0	251.0	12.5	18.0	X	○
215.0	265.0	17.0	25.0	X	○
216.0	241.5	12.7	12.7	X	○
216.0	254.0	16.0	19.0	X	○
216.0	254.0	19.0	19.0	X	○
216.9	254.0	19.0	18.5	X	○
218.0	245.0	12.5	13.5	X	○
218.0	270.0	22.0	26.0	X	○
220.0	245.0	12.5	12.5		X
220.0	250.0	12.0	15.0	X	○
220.0	250.0	15.0	15.0	X	X
220.0	250.0	16.0	15.0	X	○
220.0	250.0	19.0	15.0	X	○
220.0	254.0	16.0	17.0	X	○
220.0	255.0	16.0	17.5	X	○
220.0	255.0	18.0	17.5	X	○
220.0	258.0	25.4	19.0	X	○
220.0	260.0	15.0	20.0	X	○
220.0	260.0	16.0	20.0	X	X
220.0	260.0	20.0	20.0	X	○
220.0	260.0	22.0	20.0	X	○
220.0	270.0	16.0	25.0	X	○
225.0	250.0	12.5	12.5	X	○
225.0	260.0	16.0	17.5	X	○
225.0	270.0	16.0	22.5	X	○
226.0	258.0	16.0	16.0	X	○
228.0	268.0	16.0	20.0		X
228.0	268.0	20.0	20.0	X	○
230.0	255.0	10.0	12.5	X	○
230.0	255.0	11.7	12.5	X	○

"X" Tools available.

"○" As special part available on request.

Dimensions printed in **bold** are preferred sizes. Further sizes on request.

Radial Oil Seal



Dimensions				Type	
d ₁	d ₂	b	f	TRJ	TRL
230.0	255.0	15.0	12.5	X	○
230.0	260.0	12.5	15.0	X	○
230.0	260.0	15.0	15.0	X	○
230.0	260.0	16.0	15.0	X	○
230.0	265.0	18.0	17.5	X	○
230.0	270.0	16.0	20.0	X	X
230.0	280.0	15.0	25.0	X	○
230.0	280.0	23.0	25.0		X
230.0	285.0	23.0	27.5	X	○
234.9	273.0	19.0	19.1	X	○
235.0	270.0	16.0	17.5	X	○
235.0	270.0	18.0	17.5	X	○
235.0	275.0	20.0	17.5	X	○
236.0	276.0	16.0	20.0		X
240.0	270.0	15.0	15.0	X	○
240.0	270.0	17.0	15.0	X	○
240.0	275.0	18.0	20.0	X	○
240.0	276.0	18.0	18.0	X	○
240.0	278.0	17.0	19.0	X	○
240.0	280.0	16.0	20.0	X	X
240.0	280.0	17.5	20.0	X	○
245.0	270.0	13.0	12.5	X	○
245.0	270.0	16.0	12.5	X	X
250.0	280.0	15.0	15.0	X	○
250.0	280.0	16.0	15.0	X	X
250.0	285.0	18.0	17.5	X	○
250.0	285.0	20.0	17.5	X	○
250.0	288.0	19.0	19.0	X	○
250.0	290.0	16.0	20.0	X	X
250.0	300.0	20.0	25.0	X	○
250.0	303.0	20.0	26.5	X	○
250.0	310.0	25.0	30.0	X	○
253.0	285.0	11.0	16.0	X	○
254.0	279.0	9.3	12.5	X	○
254.0	292.0	15.9	19.0	X	○
255.0	285.0	11.0	15.0	X	X
255.0	285.0	15.0	15.0	X	○
255.0	295.0	16.0	20.0	X	X
255.0	310.0	18.0	27.5	X	○

Dimensions				Type	
d ₁	d ₂	b	f	TRJ	TRL
258.0	290.0	16.0	16.0	X	X
260.0	285.0	18.0	12.5	X	○
260.0	290.0	16.0	15.0	X	X
260.0	290.0	19.0	15.0	X	○
260.0	292.0	12.5	16.0	X	○
260.0	298.0	17.0	19.0	X	○
260.0	300.0	18.0	20.0	X	○
260.0	300.0	20.0	20.0	X	○
260.0	304.0	20.0	22.0	X	X
260.0	305.0	16.0	22.5	X	○
260.0	305.0	22.0	22.5	X	○
260.0	310.0	16.0	25.0	X	○
260.0	310.0	18.0	25.0	X	○
264.0	309.0	21.5	22.5	X	○
265.0	300.0	16.0	17.5	X	X
265.0	310.0	16.0	22.5	X	○
265.0	310.0	22.0	22.5	X	○
270.0	300.0	15.0	15.0	X	X
270.0	310.0	16.0	20.0	X	○
270.0	310.0	20.0	20.0	X	○
270.0	314.0	20.0	22.0	X	X
272.0	304.0	16.0	16.0	X	○
272.0	304.0	16.5	16.0	X	○
273.0	317.0	19.0	22.0	X	○
275.0	310.0	15.0	17.5	X	○
277.0	317.0	19.0	20.0	X	○
280.0	310.0	15.0	15.0	X	○
280.0	310.0	16.0	15.0	X	○
280.0	318.0	15.0	19.0	X	○
280.0	320.0	16.0	20.0	X	X
280.0	320.0	18.0	20.0	X	○
280.0	320.0	20.0	20.0	X	○
280.0	324.0	20.0	22.0	X	○
280.0	325.0	24.0	22.5	X	○
285.0	310.0	16.0	12.5	X	○
285.0	325.0	16.0	20.0		X
285.0	325.0	18.0	20.0	X	○
286.0	330.0	16.0	22.0	X	○
290.0	320.0	15.0	15.0	X	○

"X" Tools available.

"○" As special part available on request.

Dimensions printed in **bold** are preferred sizes. Further sizes on request.



Radial Oil Seal

Dimensions				Type	
d ₁	d ₂	b	f	TRJ	TRL
290.0	322.0	12.5	16.0	X	○
290.0	330.0	16.0	20.0	X	○
290.0	330.0	18.0	20.0	X	○
290.0	330.0	20.0	20.0	X	○
290.0	334.0	20.0	22.0	X	X
290.0	335.0	20.0	22.5	X	○
290.0	350.0	25.0	30.0	X	○
295.0	325.0	15.0	15.0	X	○
295.0	335.0	15.0	20.0		X
295.0	335.0	16.0	20.0	X	○
295.0	339.0	20.0	22.0	X	○
300.0	330.0	14.0	15.0		X
300.0	332.0	15.0	16.0	X	○
300.0	332.0	16.0	16.0	X	○
300.0	335.0	16.0	17.5	X	○
300.0	335.0	18.0	17.5	X	X
300.0	340.0	16.0	20.0	X	X
300.0	340.0	18.0	20.0	X	X
300.0	340.0	20.0	20.0	X	○
300.0	340.0	25.0	20.0	X	○
300.0	344.0	20.0	22.0	X	X
300.0	344.0	22.0	22.0	X	○
300.0	350.0	22.0	25.0	X	○
300.0	350.0	25.0	25.0	X	○
300.0	360.0	25.0	30.0	X	○
300.0	364.0	25.0	32.0	X	○
300.0	370.0	18.0	35.0	X	○
305.0	340.0	15.0	17.5	X	○
305.0	349.0	20.0	22.0	X	○
305.0	355.0	15.0	25.0	X	○
305.0	362.0	19.0	28.5	X	○
310.0	350.0	17.5	20.0	X	○
310.0	350.0	18.0	20.0	X	X
310.0	354.0	20.0	22.0	X	○
310.0	355.0	24.0	22.5	X	○
310.0	370.0	28.0	30.0	X	○
314.0	355.0	20.0	20.5	X	○
315.0	347.0	13.0	16.0	X	○
315.0	355.0	18.0	20.0	X	○

Dimensions				Type	
d ₁	d ₂	b	f	TRJ	TRL
315.0	359.0	20.0	22.0	X	○
315.0	360.0	20.0	22.5		X
315.0	365.0	20.0	25.0	X	○
315.0	380.0	29.0	32.5	X	○
317.0	361.0	20.0	22.0	X	X
320.0	350.0	15.0	15.0	X	○
320.0	355.0	16.0	17.5	X	X
320.0	360.0	18.0	20.0	X	X
320.0	360.0	20.0	20.0	X	X
320.0	364.0	20.0	22.0	X	X
323.0	363.0	16.0	20.0	X	○
325.0	365.0	16.0	20.0	X	X
325.0	365.0	20.0	20.0	X	○
325.0	365.0	22.0	20.0	X	○
325.0	369.0	20.0	22.0	X	○
325.0	375.0	22.0	25.0		X
328.0	372.0	20.2	22.0	X	○
330.0	370.0	18.0	20.0	X	○
330.0	370.0	20.0	20.0	X	X
330.0	374.0	19.0	22.0	X	○
330.0	374.0	20.0	22.0	X	X
330.0	374.0	22.0	22.0	X	○
335.0	375.0	18.0	20.0	X	○
335.0	379.0	20.0	22.0	X	X
335.0	400.0	35.0	32.5	X	○
338.0	382.0	20.0	22.0	X	○
340.0	370.0	15.0	15.0	X	○
340.0	370.0	18.0	15.0	X	○
340.0	370.0	20.0	15.0	X	○
340.0	372.0	16.0	16.0	X	○
340.0	373.0	16.0	16.5	X	○
340.0	378.0	16.0	19.0	X	○
340.0	380.0	18.0	20.0	X	○
340.0	380.0	20.0	20.0	X	○
340.0	384.0	20.0	22.0	X	○
340.0	400.0	28.0	30.0	X	○
345.0	389.0	20.0	22.0	X	○
345.0	395.0	20.0	25.0	X	○
346.0	390.0	20.0	22.0	X	○

"X" Tools available.

"○" As special part available on request.

Dimensions printed in **bold** are preferred sizes. Further sizes on request.

Radial Oil Seal



Dimensions				Type	
d ₁	d ₂	b	f	TRJ	TRL
348.0	380.0	16.0	16.0	X	○
350.0	380.0	16.0	15.0	X	○
350.0	390.0	15.0	20.0	X	○
350.0	390.0	16.0	20.0	X	○
350.0	390.0	18.0	20.0	X	○
350.0	390.0	20.0	20.0	X	X
350.0	394.0	20.0	22.0	X	X
350.0	394.0	22.0	22.0	X	○
350.0	405.0	20.0	27.5	X	○
355.0	379.0	20.0	12.0	X	○
355.0	385.0	16.0	15.0		X
355.0	394.0	20.0	19.5	X	○
355.0	410.0	25.0	27.5		X
360.0	390.0	18.0	15.0	X	○
360.0	400.0	16.0	20.0	X	○
360.0	400.0	18.0	20.0	X	○
360.0	400.0	20.0	20.0	X	○
360.0	404.0	20.0	22.0	X	X
360.0	410.0	22.0	25.0	X	○
362.0	400.0	20.0	19.0	X	○
362.0	406.0	19.5	22.0	X	○
362.0	406.0	20.0	22.0	X	○
362.0	406.0	22.0	22.0	X	○
363.0	418.0	20.0	27.5	X	○
365.0	405.0	18.0	20.0	X	○
365.0	409.0	20.0	22.0	X	X
370.0	410.0	15.0	20.0	X	○
370.0	410.0	18.0	20.0		X
370.0	410.0	20.0	20.0	X	○
370.0	414.0	19.0	22.0	X	X
370.0	414.0	20.0	22.0	X	X
370.0	414.0	25.0	22.0	X	○
375.0	419.0	20.0	22.0	X	○
375.0	419.0	22.2	22.0	X	○
375.0	420.0	16.0	22.5	X	○
378.0	428.0	18.5	25.0	X	○
380.0	410.0	12.5	15.0	X	○
380.0	420.0	15.0	20.0	X	○
380.0	420.0	15.0	20.0		X

Dimensions				Type	
d ₁	d ₂	b	f	TRJ	TRL
380.0	420.0	18.0	20.0	X	X
380.0	420.0	20.0	20.0	X	○
380.0	420.0	20.0	20.0	X	○
380.0	420.0	22.0	20.0	X	○
380.0	424.0	20.0	22.0	X	X
380.0	435.0	25.0	27.5	X	○
380.0	438.0	23.0	29.0	X	○
380.0	440.0	25.0	30.0	X	○
381.0	432.0	25.0	25.5	X	○
384.0	414.0	15.0	15.0	X	○
384.0	428.0	20.0	22.0		X
385.0	430.0	25.0	22.5	X	○
385.0	438.0	32.0	26.5	X	○
387.0	431.0	22.5	22.0	X	X
390.0	420.0	14.0	15.0	X	○
390.0	420.0	16.0	15.0	X	○
390.0	430.0	18.0	20.0	X	○
390.0	430.0	20.0	20.0	X	○
390.0	434.0	19.2	22.0	X	○
390.0	434.0	20.0	22.0	X	X
390.0	440.0	22.0	25.0		X
390.0	464.0	20.0	37.0		X
395.0	430.0	18.0	17.5	X	X
395.0	431.0	18.0	18.0	X	○
395.0	439.0	20.0	22.0	X	X
400.0	438.0	17.5	19.0	X	○
400.0	440.0	14.0	20.0		X
400.0	440.0	18.0	20.0	X	○
400.0	440.0	20.0	20.0	X	X
400.0	444.0	19.2	22.0	X	○
400.0	444.0	20.0	22.0	X	X
400.0	445.5	22.0	22.7	X	○
400.0	450.0	20.0	25.0	X	○
400.0	450.0	22.0	25.0	X	X
405.0	455.0	22.0	25.0	X	○
410.0	450.0	18.0	20.0		X
410.0	450.0	20.0	20.0	X	○
413.0	455.0	20.0	21.0	X	○
415.0	445.0	20.0	15.0	X	○

"X" Tools available.

"○" As special part available on request.

Dimensions printed in **bold** are preferred sizes. Further sizes on request.



Radial Oil Seal

Dimensions				Type	
d ₁	d ₂	b	f	TRJ	TRL
415.0	455.0	20.0	20.0	X	○
415.0	459.0	20.0	22.0	X	○
417.0	467.0	25.0	25.0	X	○
420.0	460.0	18.0	20.0		X
420.0	460.0	19.0	20.0	X	○
420.0	460.0	20.0	20.0	X	○
420.0	470.0	20.0	25.0	X	○
420.0	470.0	22.0	25.0	X	X
420.0	470.0	25.0	25.0	X	○
430.0	470.0	20.0	20.0	X	○
430.0	474.0	20.0	22.0	X	○
430.0	480.0	20.0	25.0	X	○
430.0	480.0	22.0	25.0	X	X
430.0	480.0	25.0	25.0	X	○
430.0	490.0	25.0	30.0	X	○
435.0	485.0	22.0	25.0	X	○
435.0	485.0	30.0	25.0		X
437.0	487.0	19.8	25.0	X	○
437.0	487.0	21.5	25.0	X	○
440.0	469.0	12.5	14.5	X	○
440.0	480.0	20.0	20.0	X	○
440.0	490.0	20.0	25.0	X	○
440.0	490.0	20.5	25.0	X	○
440.0	490.0	22.0	25.0	X	X
440.0	490.0	25.0	25.0	X	○
440.0	490.0	28.0	25.0		X
445.0	495.0	22.0	25.0	X	○
446.0	486.0	16.0	20.0	X	X
447.0	497.0	22.0	25.0	X	○
450.0	490.0	18.0	20.0		X
450.0	494.0	20.0	22.0	X	○
450.0	500.0	20.0	25.0	X	○
450.0	500.0	20.0	25.0		X
450.0	500.0	22.0	25.0	X	X
450.0	500.0	25.0	25.0	X	○
454.0	500.0	18.0	23.0	X	○
455.0	505.0	22.0	25.0		X
458.0	494.0	12.0	18.0	X	○
460.0	500.0	18.0	20.0	X	○

Dimensions				Type	
d ₁	d ₂	b	f	TRJ	TRL
460.0	500.0	20.0	20.0	X	○
460.0	510.0	22.0	25.0	X	X
460.0	510.0	25.0	25.0	X	○
460.0	510.8	20.6	25.4	X	○
460.0	510.8	25.4	25.4	X	○
460.0	520.0	30.0	30.0	X	○
467.0	510.0	20.0	21.5	X	○
467.0	510.0	25.0	21.5		X
470.0	520.0	22.0	25.0	X	X
470.0	520.0	25.0	25.0	X	○
474.0	514.0	20.0	20.0	X	○
475.0	530.0	18.0	27.5	X	X
475.0	530.0	20.0	27.5	X	○
477.0	527.0	22.0	25.0		X
480.0	520.0	16.0	20.0	X	○
480.0	520.0	20.0	20.0	X	○
480.0	530.0	22.0	25.0	X	X
480.0	530.0	25.0	25.0	X	○
482.0	530.0	20.0	24.0	X	○
485.0	535.0	22.0	25.0	X	○
490.0	540.0	22.0	25.0		X
495.0	545.0	25.0	25.0		X
497.0	538.0	20.0	20.5	X	○
500.0	540.0	20.0	20.0	X	○
500.0	544.0	20.0	22.0	X	○
500.0	550.0	20.0	25.0	X	X
500.0	550.0	22.0	25.0	X	X
503.0	552.0	20.0	24.5	X	○
508.0	555.0	22.0	23.5	X	○
508.0	558.0	22.0	25.0	X	○
508.0	558.0	25.0	25.0	X	○
510.0	550.0	20.0	20.0	X	○
510.0	554.0	20.0	22.0	X	○
510.0	560.0	20.0	25.0	X	○
510.0	560.0	22.0	25.0	X	○
520.0	564.0	20.0	22.0	X	○
520.0	570.0	19.0	25.0	X	○
520.0	570.0	22.0	25.0	X	○
520.0	570.0	25.0	25.0	X	○

"X" Tools available.

"○" As special part available on request.

Dimensions printed in **bold** are preferred sizes. Further sizes on request.

Radial Oil Seal



Dimensions				Type	
d ₁	d ₂	b	f	TRJ	TRL
520.0	570.8	20.6	25.4	X	○
520.0	572.0	25.0	26.0	X	○
525.0	575.0	22.0	25.0	X	X
527.0	587.0	30.0	30.0	X	○
527.0	587.0	38.0	30.0		X
528.0	578.0	22.0	25.0		X
530.0	565.0	20.0	17.5	X	○
530.0	566.0	18.0	18.0	X	○
530.0	570.0	22.0	20.0	X	○
530.0	580.0	20.0	25.0	X	○
530.0	580.0	22.0	25.0	X	○
530.0	580.0	25.0	25.0	X	○
530.0	580.8	22.2	25.4	X	○
533.0	577.0	25.0	22.0	X	○
540.0	584.0	20.0	22.0	X	○
540.0	590.0	22.0	25.0	X	X
540.0	590.0	25.0	25.0		X
542.0	578.0	18.0	18.0	X	○
545.0	595.0	22.0	25.0	X	○
550.0	600.0	22.0	25.0	X	X
550.0	610.0	25.0	30.0	X	○
555.0	605.0	22.0	25.0		X
556.0	600.0	22.0	22.0	X	○
558.0	589.0	19.0	15.5	X	○
560.0	598.0	19.0	19.0	X	○
560.0	610.0	20.0	25.0	X	○
560.0	610.0	22.0	25.0	X	○
570.0	620.0	22.0	25.0	X	X
570.0	620.0	25.0	25.0	X	○
575.0	611.0	16.0	18.0	X	○
575.0	625.0	22.0	25.0	X	○
580.0	605.4	12.7	12.7	X	○
580.0	615.0	20.0	17.5	X	○
580.0	616.0	16.0	18.0	X	X
580.0	630.0	22.0	25.0	X	○
580.0	630.0	34.0	25.0	X	○
586.0	646.0	22.0	30.0	X	○
590.0	640.0	20.0	25.0	X	○
590.0	640.0	22.0	25.0	X	○

Dimensions				Type	
d ₁	d ₂	b	f	TRJ	TRL
596.0	646.0	22.0	25.0	X	○
600.0	632.0	12.5	16.0	X	○
600.0	640.0	20.0	20.0	X	○
600.0	650.0	22.0	25.0	X	○
600.0	650.0	30.0	25.0	X	○
600.0	664.0	25.0	32.0		X
603.0	640.0	16.0	18.5	X	○
604.0	640.0	18.0	18.0	X	○
610.0	660.0	22.0	25.0	X	○
614.0	659.0	20.0	22.5	X	○
615.0	665.0	24.5	25.0	X	○
615.0	679.0	25.0	32.0	X	○
620.0	670.0	22.0	25.0	X	○
620.0	684.0	25.0	32.0	X	X
625.0	689.0	25.0	32.0	X	○
640.0	680.0	20.0	20.0		X
650.0	689.0	19.0	19.5	X	○
650.0	690.0	20.0	20.0	X	○
650.0	700.0	22.0	25.0		X
650.0	714.0	25.0	32.0	X	X
650.0	720.0	28.5	35.0		X
660.0	710.0	22.0	25.0	X	○
660.0	724.0	25.0	32.0	X	○
660.0	724.0	28.0	32.0		X
665.0	729.0	25.0	32.0	X	X
670.0	714.0	22.0	22.0		X
670.0	735.0	25.0	32.5	X	○
680.0	730.0	20.0	25.0	X	○
681.0	744.5	25.4	31.7	X	○
685.0	749.0	25.0	32.0	X	○
686.0	740.0	25.0	27.0	X	○
700.0	764.0	25.0	32.0	X	X
710.0	760.0	20.0	25.0	X	○
710.0	770.0	30.0	30.0	X	○
710.0	774.0	25.0	32.0	X	X
715.0	779.0	25.0	32.0	X	○
720.0	760.0	18.0	20.0		X
730.0	794.0	25.0	32.0	X	X
735.0	793.0	25.0	29.0		X

"X" Tools available.

"○" As special part available on request.

Dimensions printed in **bold** are preferred sizes. Further sizes on request.



Radial Oil Seal

Dimensions				Type	
d ₁	d ₂	b	f	TRJ	TRL
740.0	780.0	18.0	20.0		X
740.0	790.0	20.0	25.0	X	○
744.0	794.0	25.0	25.0		X
744.0	808.0	25.0	32.0	X	○
750.0	780.0	18.0	15.0	X	○
750.0	789.0	19.0	19.5	X	○
750.0	810.0	30.0	30.0	X	○
750.0	814.0	25.0	32.0	X	○
760.0	800.0	20.0	20.0	X	○
760.0	820.0	30.0	30.0	X	○
762.0	803.0	25.4	20.5		X
762.0	825.5	25.4	31.7	X	○
765.0	825.0	26.0	30.0	X	○
770.0	845.0	27.5	37.5		X
775.0	839.0	25.0	32.0	X	○
775.0	839.0	31.0	32.0		X
777.0	841.0	25.0	32.0	X	○
780.0	820.0	18.0	20.0	X	X
780.0	844.0	25.0	32.0	X	○
786.0	836.0	25.0	25.0	X	○
790.0	850.0	30.0	30.0	X	○
790.0	854.0	25.0	32.0	X	○
800.0	860.0	30.0	30.0	X	○
800.0	864.0	25.0	32.0	X	X
800.0	870.0	30.0	35.0	X	○
810.0	860.0	25.0	25.0	X	○
810.0	870.0	25.0	30.0	X	○
810.0	874.0	25.0	32.0		X
820.0	884.0	25.0	32.0	X	○
832.0	870.0	19.0	19.0	X	○
840.0	904.0	25.0	32.0	X	○
850.0	914.0	25.0	32.0	X	X
860.0	920.0	25.0	30.0	X	○
860.0	924.0	25.0	32.0		X
870.0	934.0	25.0	32.0		X
880.0	944.0	25.0	32.0	X	○
889.0	970.0	21.0	40.5		X
890.0	954.0	25.0	32.0	X	○
898.0	960.0	30.0	31.0		X

Dimensions				Type	
d ₁	d ₂	b	f	TRJ	TRL
900.0	960.0	30.0	30.0	X	○
910.0	966.0	25.0	28.0		X
920.0	984.0	25.0	32.0	X	○
935.0	999.0	25.0	32.0	X	○
940.0	995.0	25.0	27.5		X
940.0	1000.0	30.0	30.0	X	○
950.0	1000.0	25.0	25.0	X	○
950.0	1010.0	30.0	30.0	X	○
960.0	1024.0	25.0	32.0	X	○
1000.0	1050.0	25.0	25.0		X
1000.0	1064.0	25.0	32.0	X	○
1020.0	1084.0	25.0	32.0	X	○
1055.0	1119.0	25.0	32.0		X
1060.0	1124.0	25.0	32.0		X
1150.0	1214.0	25.0	32.0	X	○
1220.0	1284.0	25.0	32.0		X
1250.0	1300.0	22.0	25.0		X
1250.0	1314.0	25.0	32.0	X	○
1320.0	1398.0	32.0	39.0	X	○
1320.0	1420.0	49.0	50.0		X
1580.0	1644.0	25.0	32.0		X
1790.0	1854.0	24.7	32.0		X
1890.0	1954.0	25.0	32.0		X

Ordering example

TSS Code: TRJ

Dimensions: Shaft diameter: 100 mm
 Housing diameter: 115 mm
 Width: 8.9 mm

Material: NBR
 Material-Code: 4NC01

TSS Article No.	TRJ	100x115x8,9	4NC01
TSS Code			
Dimension			
Material			

"X" Tools available.
 "○" As special part available on request.
 Dimensions printed in **bold** are preferred sizes. Further sizes on request.

End Cover

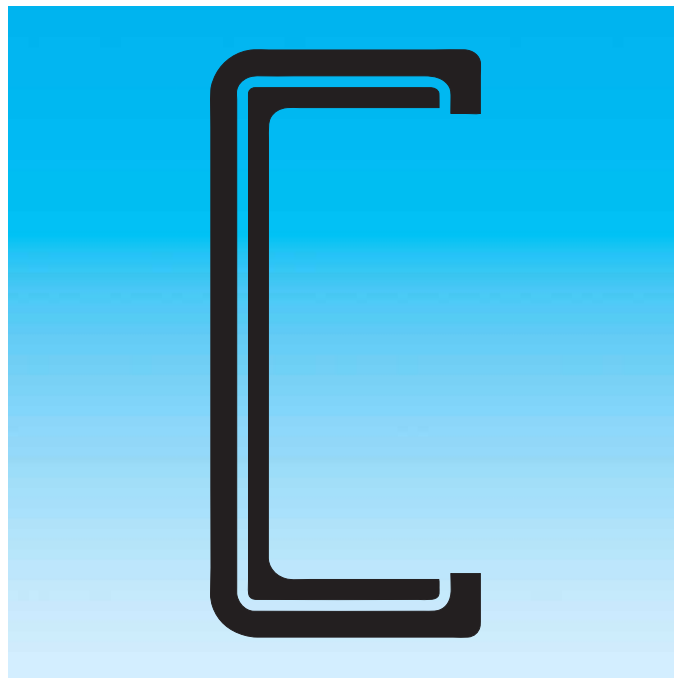





■ END COVER

General description

End covers are components to be fitted in the housing bores where no input/output shaft is located. Moreover they are used to plug and seal service bores.

Standard end covers are manufactured in accordance with bore tolerances recommended by DIN 3760 and ISO 6194/1 for radial oil seals.

Two different types of end covers are available as described in the following chapters. The type YJ38 is fully rubber covered and the type YJ39 has a "half-half" design.

■ Trelleborg Sealing Solutions type YJ 38

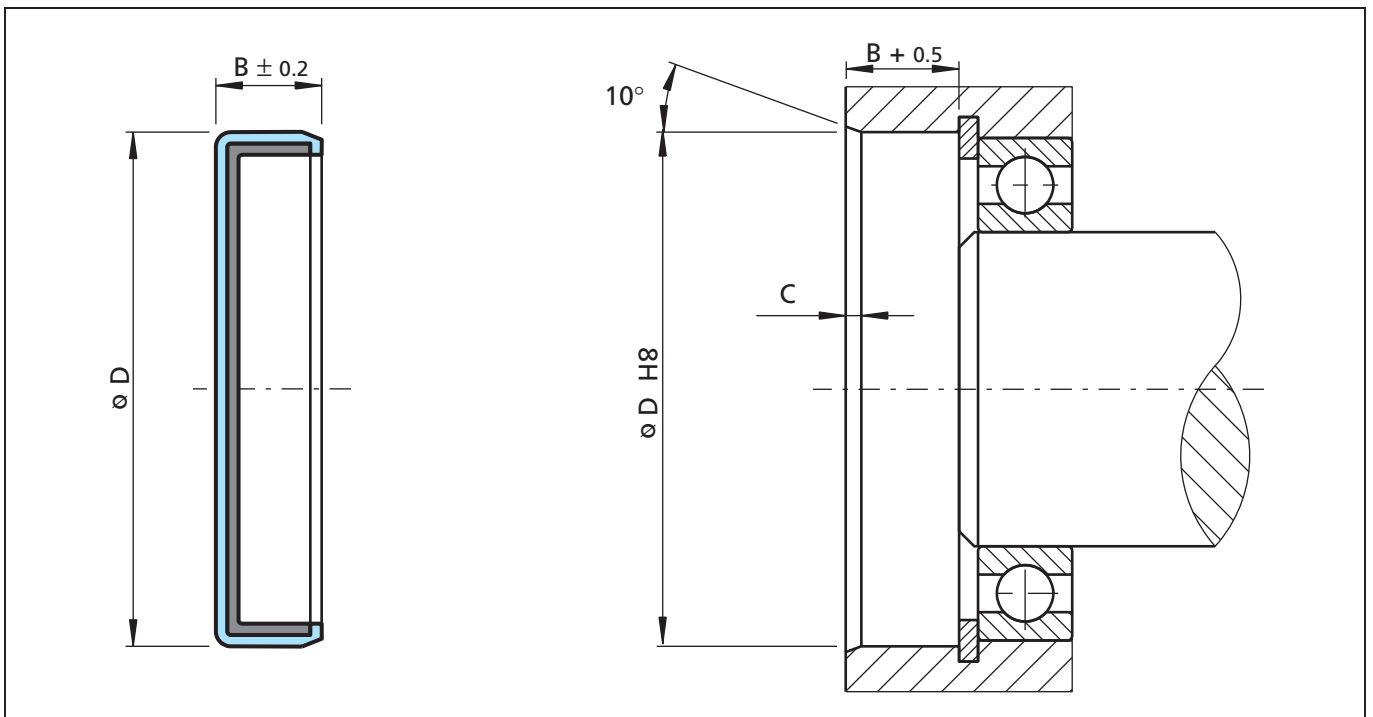

Figure 44 Installation drawing

Advantages

- Good static sealing
- Compensation of different thermal expansion
- No risk of fretting corrosion
- Effective protection against air side contaminants
- Higher bore surface roughness is allowed
- Mounting in split-housings

Application examples

- Transmission systems (e.g. gearboxes)
- Machine tool



End Cover

Technical data

Pressure: up to 0.05 MPa

Temperature: -40°C to +200°C
(depending on material)

Media: mineral and synthetic lubricants
(CLP, HLP, APGL etc.)

Trelleborg Sealing Solutions has carried out several thousands compatibility tests. Please ask for details.

Important Note:

The above data are maximum values and cannot be used at the same time, e. g. the maximum operating speed depends on material type, pressure and temperature.

Table XXXVI Materials

Standard material*	TSS material code	Standard metal insert**
NBR (70 Shore A)	N7MM	Carbon steel
NBR (75 Shore A)	4N01	Carbon steel
FKM (70 Shore A)	VCBV	Carbon steel
FKM (75 Shore A)	4V01	Carbon steel

* Special grades and other materials (ACM, EACM, EPDM, HNBR, VMQ) on request.

** Metal insert can also be supplied in different materials on request.

Ordering example end cover TSS type

TSS type: YJ
 Code: YJ38
 Dimensions: Housing diameter 50 mm
 Width 10 mm
 Material: NBR
 Material Code: N7MM

TSS Article No.	YJ38	0	0500	-	N7MM
Code					
Execution					
Shaft diameter x 10					
Quality index (standard)					
Material code (standard)					



Table XXXVII Preferred series/ Dimension, TSS part numbers

Bore D H8	Width B	Chamfer C	TSS Part No.	TSS	
				NBR	FKM
16	4	1.0	YJ3800160	X	
19	6	1.3	YJ3810190	X	
20	4	1.0	YJ3800200	X	
22	7	1.3	YJ3800220	X	
25	7	1.3	YJ3800250	X	
26	6.5	1.3	YJ3800260	X	
28	7	1.3	YJ3800280	X	X
28	9	1.5	YJ3810280	X	
30	6	1.3	YJ3810300	X	
30	8	1.5	YJ3800300	X	
32	5	1.0	YJ3820320	X	
32	7	1.3	YJ3810320	X	
32	9.5	1.5	YJ3800320	X	
35	8	1.5	YJ3800350	X	
37	5	1.0	YJ3810370	X	
37	10	1.8	YJ3800370	X	
40	7	1.3	YJ3800400	X	
42	7	1.3	YJ3810420	X	
42	9.5	1.5	YJ3800420	X	
47	6.5	1.3	YJ3800470	X	X
47	7	1.3	YJ3830470	X	
47	8	1.5	YJ3810470	X	
47	10	1.8	YJ3820470	X	X
50	10	1.8	YJ3800500	X	X
52	6.5	1.3	YJ3800520	X	
52	10	1.8	YJ3810520	X	
55	6	1.3	YJ3820550	X	
55	9	1.5	YJ3800550	X	
55	10	1.8	YJ3810550	X	
60	10	1.8	YJ3800600	X	
62	7	1.3	YJ3820620	X	
62	8	1.5	YJ3800620	X	X
65	10	1.8	YJ3800650	X	
68	8	1.5	YJ3800680	X	
70	10	1.8	YJ3800700	X	
72	9	1.5	YJ3800720	X	X



End Cover

Bore D H8	Width B	Chamfer C	TSS Part No.	TSS	
				NBR	FKM
75	7	1.3	YJ3800750	X	
75	10	1.8	YJ3810750	X	
75	12	2.0	YJ3820750	X	X
80	8	1.5	YJ3800800	X	
80	10	1.8	YJ3820800	X	
80	12	2.0	YJ3830800	X	
85	10	1.8	YJ3810850	X	
85	12	2.0	YJ3800850	X	
90	8	1.5	YJ3800900	X	
90	12	2.0	YJ3810900	X	
95	10	1.8	YJ3800950	X	
95	12	2.0	YJ3810950	X	
100	10	1.8	YJ3811000	X	X
100	12	2.0	YJ3801000	X	X
110	8	1.5	YJ3811100	X	
110	12	2.0	YJ3801100	X	
115	12	2.0	YJ3801150	X	
120	12	2.0	YJ3801200	X	
125	12	2.0	YJ3801250	X	
130	10	1.8	YJ3811300	X	
130	12	2.0	YJ3801300	X	
140	15	2.0	YJ3801400	X	
150	15	2.0	YJ3801500	X	
160	15	2.0	YJ3801600	X	
165	8	1.5	YJ3801650		X
168	11	1.8	YJ3801680	X	
168	12	2.0	YJ3811680	X	
170	15	2.0	YJ3801700	X	
180	12	2.0	YJ3801800	X	
190	12	2.0	YJ3801900	X	
200	13	2.0	YJ3802000	X	
210	15	2.0	YJ3802100	X	
230	14	2.0	YJ3802300	X	



■ Trelleborg Sealing Solutions type YJ 39

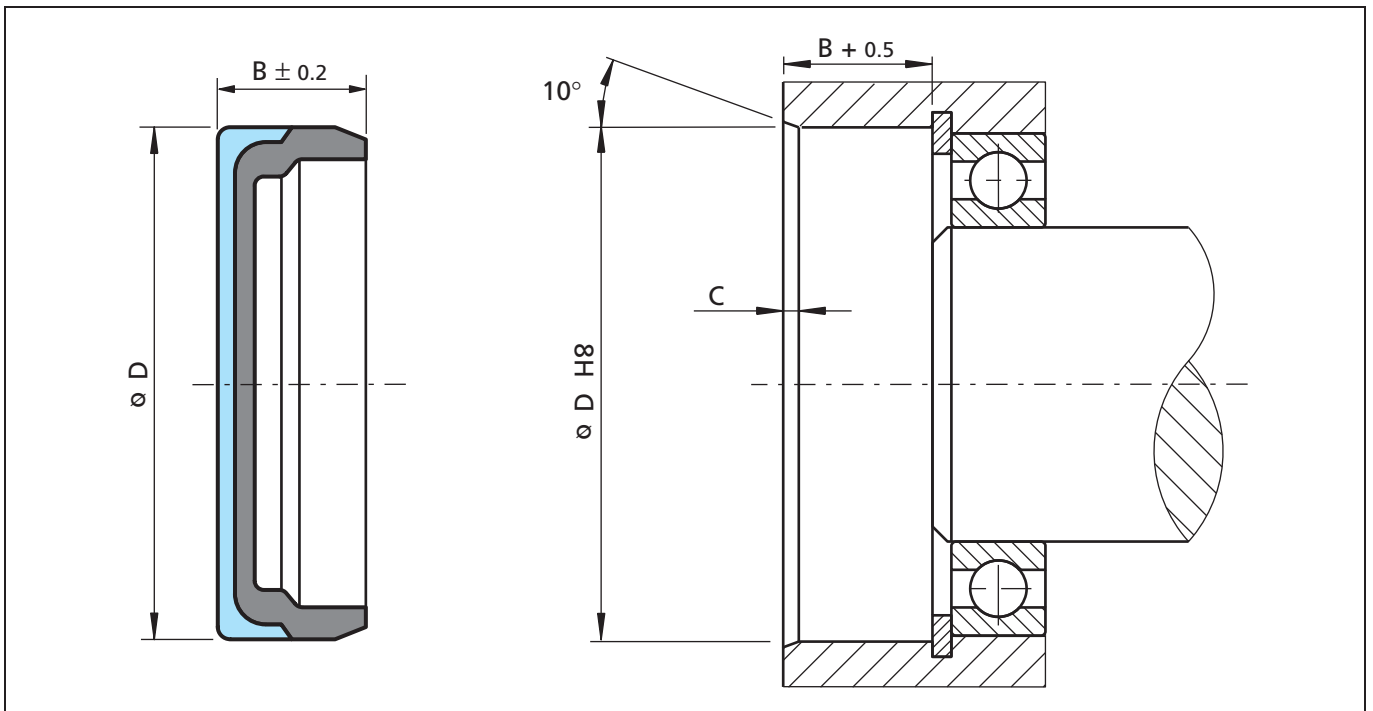

Figure 45 Installation drawing

Advantages

- Good static sealing and stiffness (no pop-out effect)
- Compensation of different thermal expansion
- No risk of fretting corrosion
- Effective protection against air side contaminants
- Higher bore surface roughness is allowed
- Mounting in split-housings
- Good heat transfer

Application examples

- Transmission systems (e.g. gearboxes)
- Machine tools

Technical data

Pressure:	up to 0.5 MPa
Temperature:	-40°C to +200°C (depending on material)
Media:	mineral and synthetic lubricants (CLP, HLP, APGL etc.)

Trelleborg Sealing Solutions has carried out several thousands compatibility tests. Please ask for details.

Important Note:

The above data are maximum values and cannot be used at the same time, e. g. the maximum operating speed depends on material type, pressure and temperature.



End Cover

Table XXXVIII Materials

Standard material*	TSS material code	Standard metal insert**
NBR (70 Shore A)	N7MM	Carbon steel

* Special grades and other materials (FKM, ACM, EACM EPDM, HNBR, VMO) on request.

** Metal insert can be supplied in different materials on request.

Ordering example end cover TSS type

TSS type: YJ
 Code: YJ39
 Dimensions: Housing diameter 52 mm
 Width 6 mm
 Material: NBR
 Material Code: N7MM

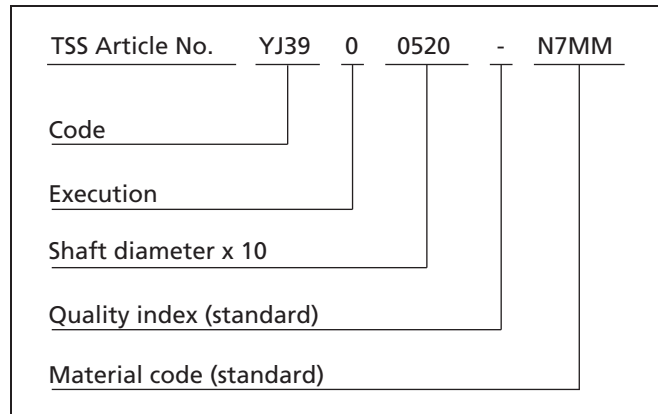
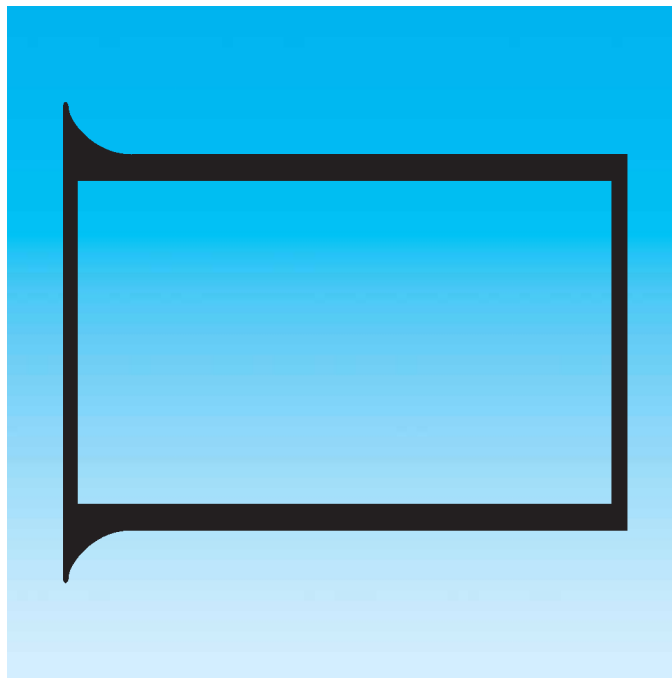

Table XXXIX Preferred series / Dimension, TSS part numbers

Bore D H8	Width B	Chamfer C	TSS Part No.	TSS
				NBR
22	7	1.3	YJ3900220	X
28	7	1.3	YJ3900280	X
35	7	1.3	YJ3900350	X
40	7	1.3	YJ3900400	X
42	7	1.3	YJ3900420	X
47	7	1.3	YJ3900470	X
52	6	1.3	YJ3900520	X
65	10	1.8	YJ3900650	X
72	9	1.5	YJ3900720	X
75	8	1.5	YJ3900750	X
80	8	1.5	YJ3900800	X
90	10	1.8	YJ3900900	X
100	10	1.8	YJ3901000	X
115	12	2.0	YJ3901150	X
140	15	2.0	YJ3901400	X
145	12	2.0	YJ3901450	X
210	15	2.0	YJ3902100	X

Shaft Repair Kit







■ SHAFT REPAIR KIT

General description

The shaft repair kit serves as a running surface for rotary shaft lip seals. It consists of a thin-walled cylindrical tube with a mounting flange (see Figure 46). The flange has a design breaking point and can – if it is an obstacle – be removed.

The shaft repair kit has a wall thickness of approx. 0.254 mm and a spiral free ground surface. It is ideally suited as a counter face for rotary shaft lip seals.

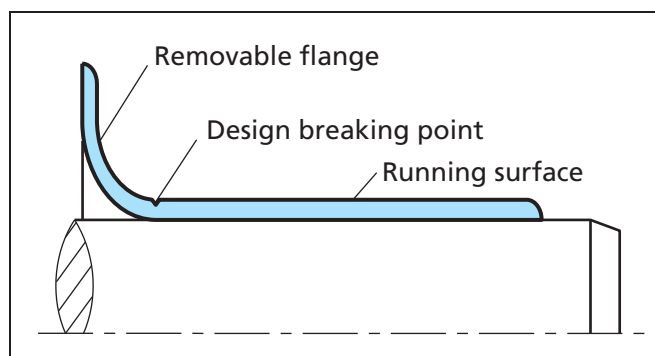

Figure 46 Design of the shaft repair kit

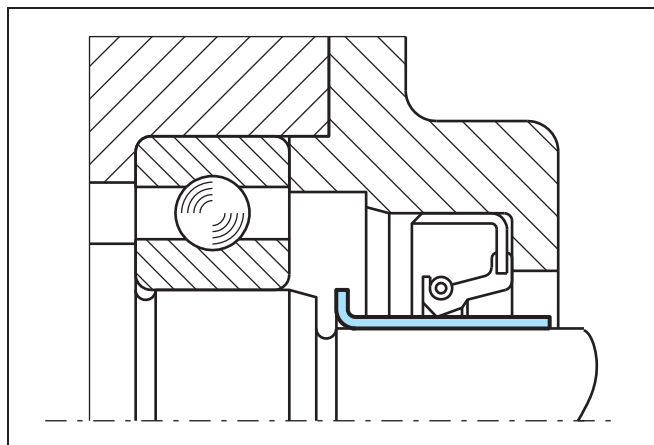

Figure 47 Running surface with shaft repair kit

Advantages

- Inexpensive replacement of worn shaft surfaces
- Simple and quick installation with supplied assembly tool
- No alterations to the seal dimensions
- Wear-resistant surface for long service life
- Secure seating due to a force fit

Application examples

- Repair of worn shaft surfaces
- Used in new designs to save costs for surface treatment

Technical data

Material:	Stainless steel, AISI 304 (1.4301)
Material Code:	900V
Wall thickness:	0.254 mm
Surface:	Ground spiral-free, ($R_a = 0.25 \dots 0.5\mu\text{m}$)
Hardness:	95 HRB



Shaft Repair Kit

Installation instructions

The shaft repair kit is fitted using the installation tool supplied. The raised mounting flange and the tool supplied ensure an exact fit.

Together they prevent tilting during installation and thus damage to the sealing surface.

Observe the following points before installation:

- Remove dust, dirt, rust, etc. from the damaged running surface
- Repair deep running scores with filling compound, e.g. metal-filled synthetic resin
- Check that the shaft has a lead-in chamfer

Installation sequence

- Check the nominal diameter of the shaft. The oversize to the nominal dimension of the shaft must be taken into consideration
- Place the shaft repair kit with the mounting flange facing forward onto the shaft.
- Push on the installation tool.
- Push on the shaft repair kit by striking the installation tool with a hammer or use a press.
- If necessary, cut the mounting flange using side cutters up to the design breaking point and break off the flange at the line.
- Grease the shaft repair kit before fitting the seal

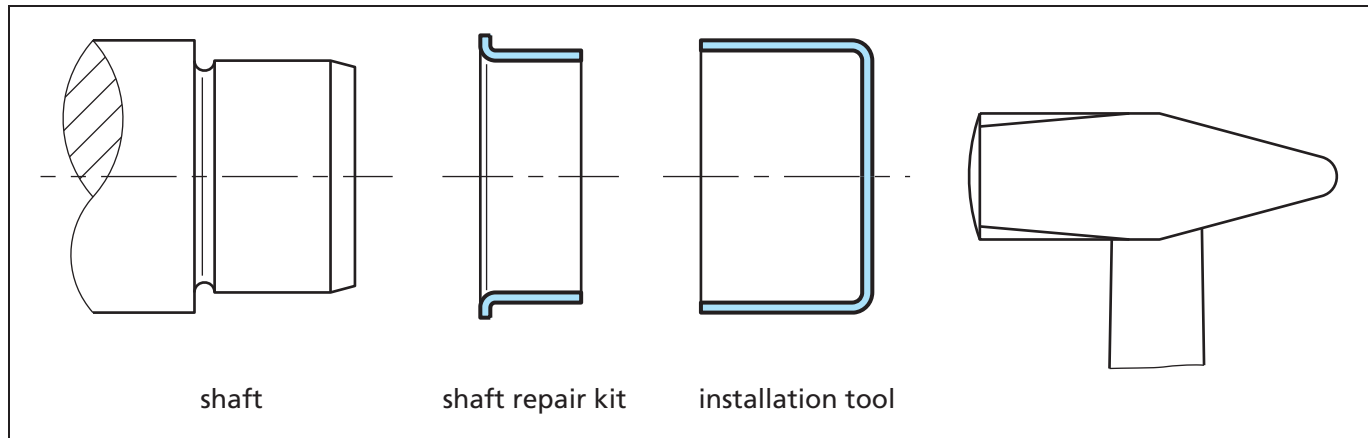

Figure 48 Installation sequence



■ Installation recommendation, metric sizes

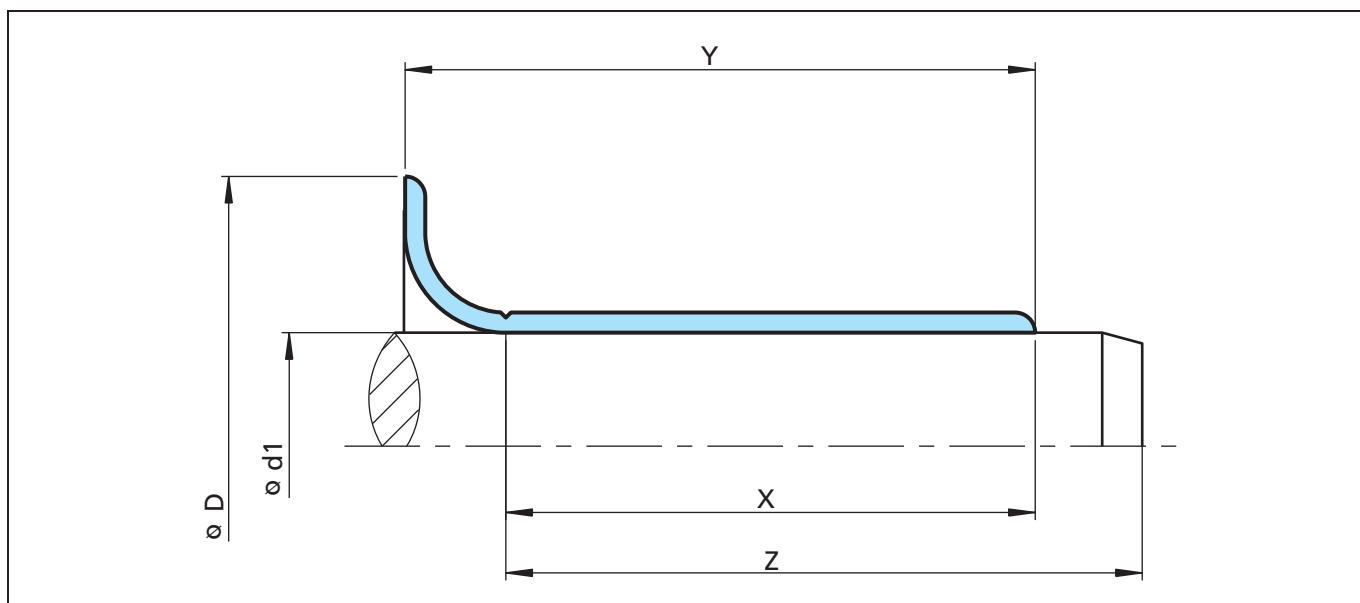

Figure 49 Installation drawing

Table XL Installation dimension / TSS part no.

Shaft diameter metric sizes			Length without flange	Overall length	Flange diameter	Max. installation depth	TSS Article no.
Nominal dia.	Range						
d_1	min.	max.	$X \pm 0.8$	$Y \pm 0.8$	$D \pm 1.6$	Z	
12.0	11.93	12.07	6.0	8.4	20.0	12.0	TS0099049-900V
15.0	14.96	15.06	5.0	9.0	19.1	11.0	TS0099059-900V
17.0	16.94	17.04	8.0	11.0	22.2	51.0	TS0099068-900V
18.0	17.89	18.00	8.0	11.0	27.0	46.0	TS0099082-900V
20.0	19.94	20.04	8.0	11.0	23.6	51.0	TS0099078-900V
22.0	21.87	22.00	8.0	12.0	30.2	46.0	TS0099085-900V
25.0	24.94	25.04	8.0	11.0	33.0	51.0	TS0099098-900V
26.0	25.87	26.00	8.0	12.0	33.3	46.0	TS0099103-900V
28.0	27.94	28.04	9.5	12.7	34.9	71.0	TS0099111-900V
30.0	29.95	30.07	8.0	11.0	35.6	17.0	TS0099114-900V
32.0	31.93	32.08	8.0	11.1	38.0	18.0	TS0099128-900V
35.0	34.93	35.08	13.0	16.0	41.6	20.0	TS0099139-900V
36.0	35.84	36.00	13.0	17.0	42.9	25.0	TS0099146-900V
38.0	37.84	38.00	13.0	17.0	45.2	25.0	TS0099147-900V
40.0	39.93	40.08	13.0	16.0	47.0	26.0	TS0099157-900V
42.0	41.86	42.00	14.3	17.5	53.0	21.0	TS0099169-900V
45.0	44.93	45.09	14.0	17.0	53.0	21.0	TS0099177-900V
48.0	47.92	48.08	14.0	17.0	56.0	25.0	TS0099189-900V



Shaft Repair Kit

Shaft diameter metric sizes			Length without flange	Overall length	Flange diameter	Max. installation depth	TSS Article no.
Nominal dia.	Range						
d_1	min.	max.	$X \pm 0.8$	$Y \pm 0.8$	$D \pm 1.6$	Z	
50.0	49.91	50.06	14.0	17.0	57.0	25.0	TS0099196-900V
55.0	54.91	55.07	20.0	23.0	62.0	32.0	TS0099215-900V
60.0	59.92	60.07	20.0	23.0	70.7	35.0	TS0099235-900V
62.0	61.85	62.00	12.7	15.9	71.8	36.0	TS0099242-900V
65.0	64.92	65.07	20.0	23.0	72.4	35.0	TS0099254-900V
70.0	69.85	70.00	10.3	14.3	79.4	31.0	TS0099272-900V
70.0	69.93	70.08	20.0	24.0	79.4	32.0	TS0099276-900V
75.0	74.93	75.08	22.0	26.0	84.0	33.0	TS0099294-900V
80.0	79.81	80.01	19.1	22.5	89.9	35.0	TS0099313-900V
80.0	79.91	80.09	21.0	24.0	90.0	35.0	TS0099315-900V
85.0	84.78	85.00	21.0	25.0	94.0	35.0	TS0099333-900V
90.0	89.92	90.07	23.0	28.0	101.6	44.0	TS0099354-900V
95.0	94.92	95.07	21.0	24.0	102.2	44.0	TS0099369-900V
100.0	99.85	100.10	20.6	25.4	110.0	52.0	TS0099393-900V
105.0	104.90	105.11	20.0	23.0	113.5	35.0	TS0099413-900V
110.0	109.90	110.10	12.9	16.5	125.0	31.0	TS0099435-900V
115.0	114.88	115.09	20.6	23.8	127.0	32.0	TS0099452-900V
120.0	119.89	120.09	20.0	25.0	129.8	32.0	TS0099473-900V
125.0	124.89	125.10	26.0	32.0	137.2	37.0	TS0099492-900V
130.0	129.98	130.18	22.0	25.3	139.5	33.0	TS0099491-900V
135.0	134.79	135.00	20.5	25.4	149.2	32.0	TS0099533-900V
140.0	139.90	140.11	20.5	25.5	151.0	32.0	TS0099552-900V
150.0	149.75	150.00	26.0	30.0	159.0	34.0	TS0099595-900V
155.0	154.75	155.00	26.0	30.0	167.0	33.0	TS0099606-900V
160.0	159.97	160.23	25.4	31.8	177.8	46.0	TS0099630-900V
165.0	164.97	165.23	25.4	31.8	177.8	44.0	TS0099650-900V
170.0	169.75	170.00	31.8	38.0	182.6	55.0	TS0099640-900V
175.0	174.75	175.00	28.0	32.0	187.0	35.0	TS0099687-900V
180.0	179.76	180.00	33.0	38.0	190.5	45.0	TS0099721-900V
185.0	184.73	185.00	32.0	38.0	199.0	55.0	TS0099726-900V
200.0	199.87	200.13	34.5	38.1	212.7	44.0	TS0099787-900V



■ Installation recommendation, inch sizes

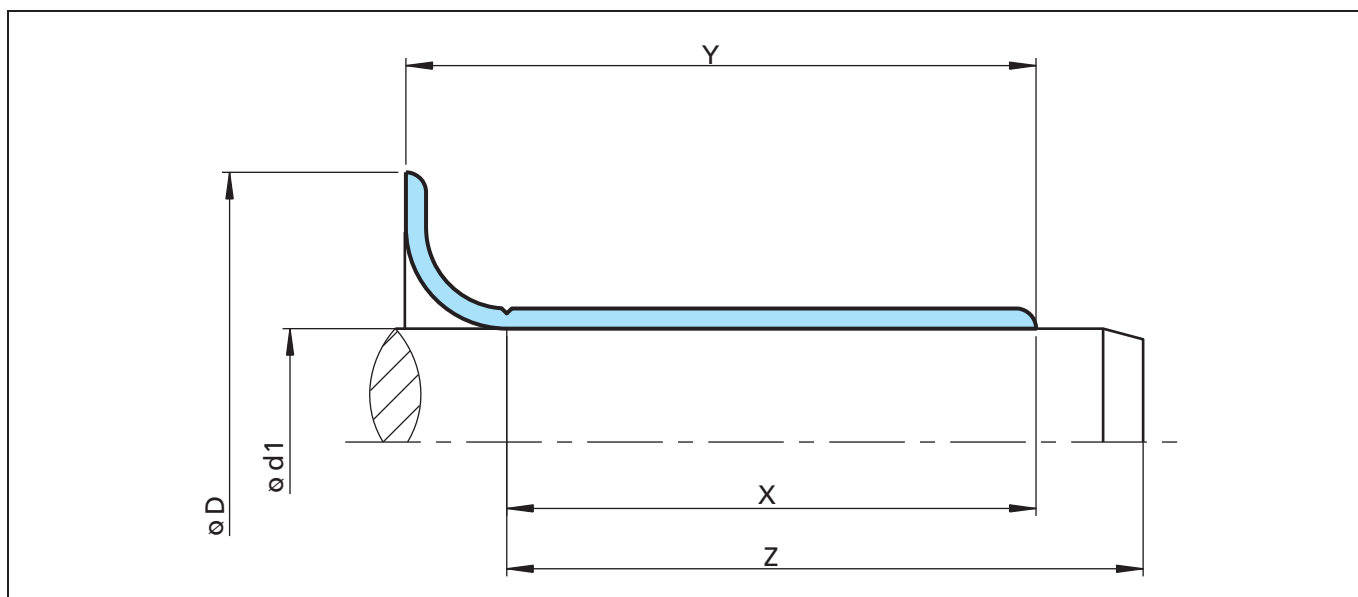

Figure 50 Installation drawing

Table XLI Installation Dimensions in Inches

Shaft diameter inch sizes		Length without flange	Overall length	Flange diameter	Max. installation depth	TSS Article no.
Nominal dia.	Range					
d_1	min. max.	$X \pm 0.031$	$Y \pm 0.031$	$D \pm 0.063$	Z	
0.500	0.498 0.502	0.250	0.344	0.610	2.000	TS0099050-900V
0.563	0.560 0.566	0.250	0.391	0.750	1.831	TS0099056-900V
0.625	0.623 0.627	0.313	0.406	0.750	2.000	TS0099062-900V
0.750	0.748 0.752	0.313	0.438	0.945	2.000	TS0099076-900V
0.781	0.780 0.784	0.313	0.438	0.935	2.000	TS0099080-900V
0.859	0.857 0.861	0.250	0.373	1.155	2.000	TS0099086-900V
0.875	0.873 0.877	0.313	0.438	1.094	2.000	TS0099087-900V
0.969	0.966 0.970	0.313	0.438	1.130	2.000	TS0099094-900V
0.969	0.966 0.970	0.625	0.719	1.130	2.000	TS0099096-900V
1.000	0.998 1.002	0.313	0.438	1.219	2.000	TS0099100-900V
1.063	1.060 1.064	0.313	0.438	1.320	2.813	TS0099106-900V
1.125	1.123 1.127	0.313	0.438	1.500	0.688	TS0099112-900V
1.156	1.154 1.158	0.375	0.500	1.350	0.688	TS0099120-900V
1.188	1.185 1.190	0.313	0.438	1.400	0.688	TS0099118-900V
1.240	1.237 1.243	0.315	0.438	1.540	0.688	TS0099141-900V
1.250	1.247 1.253	0.313	0.438	1.500	0.688	TS0099125-900V
1.313	1.308 1.314	0.250	0.375	1.600	0.813	TS0099129-900V
1.313	1.310 1.316	0.500	0.625	1.594	1.813	TS0099131-900V



Shaft Repair Kit

Shaft diameter inch sizes			Length without flange	Overall length	Flange diameter	Max. installation depth	TSS Article no.
Nominal dia.	Range						
d_1	min.	max.	$X \pm 0.031$	$Y \pm 0.031$	$D \pm 0.063$	Z	
1.375	1.371	1.377	0.313	0.438	1.638	0.813	TS0099133-900V
1.375	1.371	1.377	0.500	0.625	1.638	0.813	TS0099138-900V
1.438	1.432	1.438	0.563	0.688	1.690	1.016	TS0099143-900V
1.438	1.435	1.441	0.375	0.500	1.781	1.016	TS0099144-900V
1.500	1.497	1.503	0.563	0.688	1.781	1.016	TS0099149-900V
1.500	1.497	1.503	0.375	0.500	1.781	1.016	TS0099150-900V
1.563	1.559	1.565	0.563	0.688	1.859	1.016	TS0099156-900V
1.625	1.622	1.628	0.313	0.438	1.875	1.016	TS0099161-900V
1.625	1.623	1.628	0.563	0.688	1.875	0.813	TS0099162-900V
1.688	1.685	1.691	0.313	0.438	1.906	0.875	TS0099167-900V
1.688	1.684	1.690	0.563	0.688	1.906	0.875	TS0099168-900V
1.719	1.715	1.721	0.563	0.688	2.031	0.813	TS0099171-900V
1.750	1.747	1.753	0.375	0.500	2.055	0.813	TS0099172-900V
1.750	1.747	1.753	0.563	0.688	2.063	0.813	TS0099174-900V
1.750	1.747	1.753	0.750	0.875	2.063	0.813	TS0099175-900V
1.750	1.747	1.753	0.531	0.625	2.063	0.812	TS0099180-900V
1.781	1.778	1.784	0.664	0.800	2.125	1.125	TS0099179-900V
1.875	1.872	1.878	0.375	0.516	2.203	1.050	TS0099184-900V
1.875	1.872	1.878	0.563	0.688	2.203	1.000	TS0099187-900V
1.875	1.872	1.878	0.295	0.415	2.203	0.744	TS0099188-900V
1.875	1.872	1.878	0.175	0.295	2.203	0.744	TS0099190-900V
1.938	1.934	1.940	0.563	0.688	2.219	1.000	TS0099193-900V
1.969	1.965	1.971	0.551	0.688	2.244	0.984	TS0099196-900V
2.000	1.997	2.003	0.563	0.688	2.406	1.050	TS0099199-900V
2.000	1.997	2.003	0.875	1.000	2.406	1.000	TS0099200-900V
2.063	2.057	2.063	0.781	0.938	2.469	1.375	TS0099205-900V
2.125	2.123	2.128	0.500	0.750	2.422	1.281	TS0099210-900V
2.125	2.124	2.130	0.781	0.938	2.422	1.375	TS0099212-900V
2.188	2.186	2.192	0.781	0.938	2.500	1.313	TS0099218-900V
2.250	2.249	2.255	0.781	0.938	2.531	1.313	TS0099225-900V
2.250	2.249	2.255	0.313	0.438	2.531	1.313	TS0099227-900V
2.313	2.309	3.315	0.781	0.938	2.688	1.375	TS0099231-900V
2.375	2.369	2.375	0.781	0.938	2.750	1.375	TS0099236-900V
2.375	2.374	2.380	0.781	0.938	2.750	1.375	TS0099237-900V
2.375	2.372	2.378	0.594	0.750	2.750	1.375	TS0099238-900V
2.375	2.374	2.380	0.526	0.683	2.750	1.375	TS0099240-900V



Shaft Repair Kit



Shaft diameter inch sizes			Length without flange	Overall length	Flange diameter	Max. installation depth	TSS Article no.
Nominal dia.	Range						
d_1	min.	max.	$X \pm 0.031$	$Y \pm 0.031$	$D \pm 0.063$	Z	
2.438	2.435	2.441	0.500	0.625	2.828	1.425	TS0099242-900V
2.438	2.434	2.440	0.781	0.938	2.828	1.375	TS0099243-900V
2.500	2.500	2.506	0.500	0.656	2.828	1.393	TS0099248-900V
2.500	2.500	2.506	0.781	0.938	2.820	1.375	TS0099250-900V
2.563	2.560	2.566	0.781	0.938	2.850	1.375	TS0099256-900V
2.625	2.622	2.628	0.500	0.625	3.047	1.375	TS0099260-900V
2.625	2.621	2.627	0.781	0.938	3.047	1.375	TS0099262-900V
2.625	2.621	2.627	0.781	0.906	3.047	1.562	TS0099264-900V
2.750	2.747	2.753	1.438	1.625	3.075	1.625	TS0099267-900V
2.750	2.750	2.756	1.125	1.250	3.125	1.313	TS0099269-900V
2.750	2.747	2.753	0.781	0.906	3.125	1.250	TS0099270-900V
2.750	2.750	2.756	0.406	0.563	3.125	1.250	TS0099272-900V
2.750	2.745	2.751	0.781	0.938	3.125	1.250	TS0099274-900V
2.750	2.750	2.756	0.781	0.938	3.125	1.250	TS0099275-900V
2.813	2.809	2.815	0.594	0.688	3.188	1.250	TS0099281-900V
2.875	2.873	2.879	0.781	0.938	3.219	1.250	TS0099287-900V
2.938	2.937	2.943	0.781	0.938	3.344	1.250	TS0099293-900V
3.000	2.997	3.003	0.813	0.938	3.240	1.375	TS0099296-900V
3.000	3.000	3.006	0.813	1.000	3.235	1.281	TS0099300-900V
3.000	3.000	3.006	0.625	0.813	3.345	1.063	TS0099303-900V
3.125	3.124	3.132	0.551	0.709	3.525	2.031	TS0099307-900V
3.125	3.120	3.126	0.688	0.813	3.531	2.000	TS0099311-900V
3.125	3.120	3.126	0.813	1.000	3.531	2.000	TS0099312-900V
3.250	3.247	3.253	0.813	1.000	3.594	1.375	TS0099322-900V
3.250	3.250	3.256	0.595	0.719	3.575	1.375	TS0099324-900V
3.250	3.250	3.256	0.813	1.000	3.585	1.375	TS0099325-900V
3.375	3.373	3.379	0.813	1.000	3.695	1.375	TS0099337-900V
3.375	3.373	3.379	0.375	0.500	3.688	1.410	TS0099338-900V
3.438	3.435	3.441	0.781	0.906	3.844	1.406	TS0099339-900V
3.500	3.500	3.506	0.313	0.500	3.825	1.347	TS0099347-900V
3.500	3.500	3.506	0.813	1.000	3.844	1.347	TS0099350-900V
3.563	3.560	3.566	0.813	1.000	3.900	1.750	TS0099356-900V
3.625	3.623	3.629	0.813	1.000	4.031	1.750	TS0099362-900V
3.625	3.623	3.629	0.500	0.625	4.025	1.750	TS0099363-900V
3.688	3.685	3.691	0.813	0.938	4.025	1.750	TS0099365-900V
3.688	3.684	3.690	0.313	0.438	3.830	0.875	TS0099368-900V



Shaft Repair Kit

Shaft diameter inch sizes			Length without flange	Overall length	Flange diameter	Max. installation depth	TSS Article no.
Nominal dia.	Range						
d_1	min.	max.	$X \pm 0.031$	$Y \pm 0.031$	$D \pm 0.063$	Z	
3.750	3.750	3.756	0.344	0.500	4.025	1.750	TS0099367-900V
3.750	3.750	3.756	0.688	0.875	4.020	1.875	TS0099372-900V
3.750	3.746	3.752	0.563	0.688	4.025	1.750	TS0099376-900V
3.875	3.873	3.879	0.813	1.000	4.219	1.875	TS0099387-900V
4.000	3.398	4.006	0.600	0.725	4.375	2.050	TS0099395-900V
4.000	3.398	4.006	0.813	1.000	4.375	2.050	TS0099399-900V
4.000	3.398	4.006	0.650	0.775	4.375	1.375	TS0099400-900V
4.000	3.398	4.006	0.500	0.625	4.375	1.375	TS0099401-900V
4.125	4.122	4.130	0.813	1.000	4.420	1.375	TS0099412-900V
4.188	4.183	4.191	0.813	1.000	4.500	1.375	TS0099418-900V
4.234	4.226	4.234	0.781	0.906	4.610	1.438	TS0099423-900V
4.250	4.248	4.256	0.813	1.000	4.610	1.438	TS0099424-900V
4.328	4.327	4.335	0.509	0.650	4.921	1.250	TS0099435-900V
4.375	4.370	4.378	0.813	1.000	4.750	1.650	TS0099437-900V
4.406	4.401	4.409	0.748	0.886	4.750	1.063	TS0099438-900V
4.438	4.434	4.442	1.000	1.142	4.813	1.313	TS0099439-900V
4.500	4.496	4.504	0.813	1.000	4.900	1.250	TS0099450-900V
4.625	4.621	4.629	1.000	1.250	5.063	1.375	TS0099463-900V
4.625	4.621	4.628	0.438	0.625	4.875	1.375	TS0099465-900V
4.688	4.685	4.693	0.813	1.000	5.063	1.375	TS0099468-900V
4.750	4.746	4.754	0.500	0.750	5.000	1.500	TS0099475-900V
4.875	4.871	4.879	0.625	0.750	5.250	1.438	TS0099487-900V
5.125	5.117	5.125	0.866	0.996	5.493	1.280	TS0099491-900V
5.125	5.120	5.128	0.813	1.000	5.500	1.250	TS0099513-900V
5.250	5.246	5.254	0.813	1.000	5.560	1.250	TS0099525-900V
5.313	5.307	5.315	0.807	1.000	5.875	1.250	TS0099533-900V
5.375	5.371	5.379	0.813	1.000	5.875	1.250	TS0099537-900V
5.438	5.434	5.442	1.500	1.688	5.750	1.875	TS0099548-900V
5.500	5.498	5.506	0.813	1.000	5.938	1.250	TS0099549-900V
5.750	5.746	5.754	0.813	1.000	6.180	1.750	TS0099575-900V
6.000	5.995	6.003	1.000	1.250	6.375	1.750	TS0099599-900V
6.000	5.995	6.003	0.500	0.750	6.360	1.750	TS0099601-900V
6.063	6.058	6.068	1.024	1.181	6.375	1.299	TS0099605-900V
6.203	6.198	6.208	0.813	1.063	6.625	1.750	TS0099620-900V
6.250	6.245	6.255	1.031	1.250	6.625	1.750	TS0099625-900V
6.500	6.495	6.505	1.000	1.250	7.000	1.750	TS0099650-900V



Shaft Repair Kit



Shaft diameter inch sizes			Length without flange	Overall length	Flange diameter	Max. installation depth	TSS Article no.
Nominal dia.	Range						
d_1	min.	max.	$X \pm 0.031$	$Y \pm 0.031$	$D \pm 0.063$	Z	
6.688	6.683	6.693	1.250	1.496	7.188	2.175	TS0099640-900V
6.750	6.745	6.755	0.813	1.063	7.175	1.750	TS0099675-900V
7.000	6.995	7.005	1.000	1.250	7.475	1.688	TS0099700-900V
7.250	7.244	7.254	1.250	1.500	7.760	2.175	TS0099725-900V
7.500	7.495	7.505	0.813	1.000	7.875	1.250	TS0099750-900V
7.750	7.745	7.755	1.000	1.313	8.270	1.875	TS0099775-900V
7.875	7.869	7.879	1.359	1.500	8.375	1.750	TS0099787-900V
8.000	7.795	8.005	1.000	1.250	8.375	1.750	TS0099800-900V



Shaft Repair Kit

Cassette Seal







■ CASSETTE SEAL

■ General

The Cassette Seal has been developed to meet the ever-increasing requirements of long service life, high functional reliability, environmental safety, simple handling and superior total economy.

Cassette Seals are fully enclosed seals with an integrated sealing system, that performs the function of oil seal, wear sleeve and dust protection in one unit. No extra components such as shaft sleeves or dirt protection are needed.

Unique to all the Trelleborg Sealing Solutions Cassette seals is that the sealing lip is fixed on the stationary part of the hardware. Because of this the sealing force is constant, independent of the rotary speed.

Cassette seals consist of several individual features working together, built into one unit and for this reason they are called "Systems".

The TSS Cassette Seals were originally designed at FORSHEDA AB in Sweden and sold under the trade name STEFA.

■ System 500

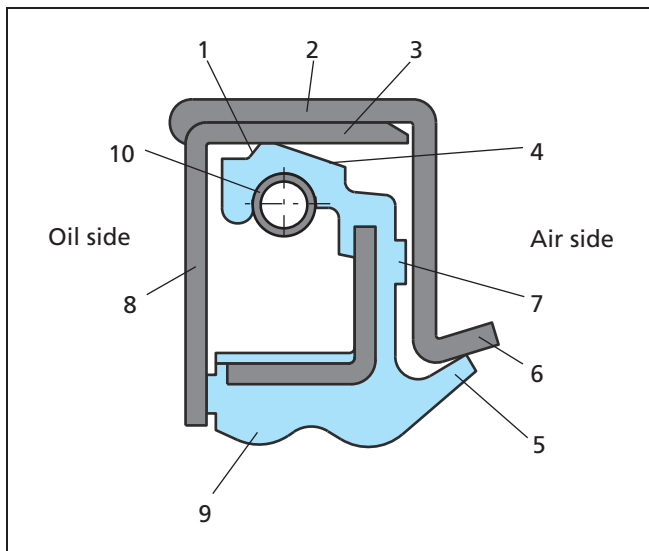

Figure 51 System 500

System 500, the original Unitized Wheel Hub Seal for heavy-duty vehicles, is designed for rotating hubs.

The inner section of the System 500 is secured against the shaft. The outer section, press fitted into the wheel hub, rotates together with the hub around the inner section, creating a completely enclosed seal. Dirt and water, the major enemies of hub seals, are effectively kept at distance,

whilst the lubrication of the rubber lip remains intact. This decreases friction and increases seal life accordingly.

The main features of the System 500 are:

- The sealing (1) element is non-rotating, which means that the radial force is kept unchanged at various speeds.
- The sealing surface (2) is in close contact with the wheel hub, which gives an excellent heat transfer.
- The structure of the sealing counterface (3) has been chosen after several thousands of test hours. The position of the sealing lip ensures best lubrication.
- The sealing lip (4) normally has bi-directional TURBO-pattern (see page 150).
- Integral prelubricated dust-sealing (5) functions.
- The protruding conical part (6) of the case deflects heavier particles due to the centrifugal force.
- The excluding lip (5) protects against water splash and finer particles.
- Molded distance lugs (7) automatically locate the sealing element in the right position.
- The lugs (7) are spaced and dimensioned to ensure the sealing lip has adequate lubrication.
- The inner case (8) also protects the sealing lip from direct oil spray caused by taper roller bearings.

The robust ribs (9) give:

- a firm seat on the shaft
- a smooth sliding during installation
- a positive static seal even if one of the ribs is located on a defective shaft surface
- The compression spring (10) maintains the radial force. The initial force exerted by the sealing element will in some applications reduce due to aging of the rubber exposed to heat, load or chemical action.

- For such applications where the seal is exposed to dirty environment, i.e. off road use, the System 500 can be equipped with an additional specially developed dirt protection, the HRV seal.

- In cases where the space does not allow the use of the HRV seal, the System 500HD, a derivative of System 500, can be used. It has the same outside dimensions, but an extra dust lip inside. Since the casing is identical to System 500 it is readily available in the same sizes. Please contact you local Trelleborg Sealing Solutions marketing company for more details.



Cassette Seal

■ System 3000

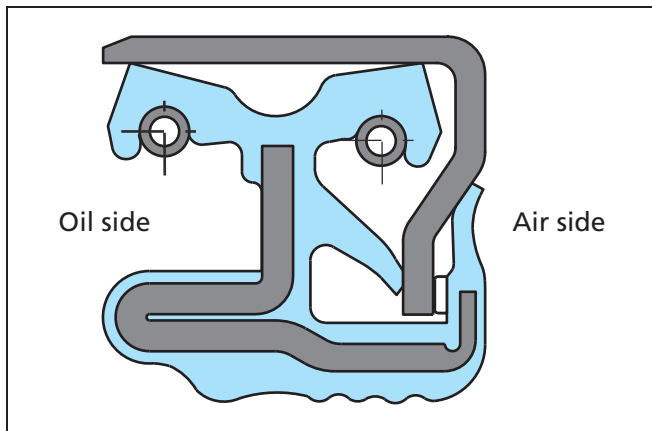

Figure 52 System 3000

System 3000 is specifically designed for rotating hubs on off-road machines in heavy duty applications, i.e. wet rice fields. The design offers significant improvements in providing improved ability to exclude water, dirt and dust for much longer time. Its ability to sustain eccentricities, over-pressure and shaft misalignments are equal to Radial Seals.

The System 3000, while based on System 500, features two sealing lips, equipped with compression springs, to provide excellent sealing performance and an additional dust lip. Mudbox-tests are showing more than doubled lifetime performance compared with the other system seals.

■ System 5000

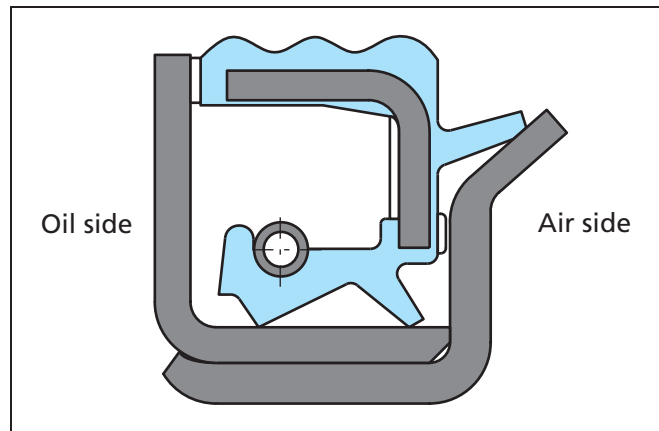

Figure 53 System 5000

The System 5000 is, like System 500 and System 3000, a fully enclosed seal however designed for rotating shafts. The System 5000 has the same features but the design has been inverted, i.e. the sealing element is fixed in the stationary housing and the casing components rotates with the shaft.

The System 5000 is used to prevent oil from leaking out of a bearing housing, i.e. a differential pinion housing for rear axles on trucks, and at the same time preventing road dirt, salt and water splash to enter.

The design is compact and integrates the necessary shaft counterface as well as the dirt exclusion. The dirt exclusion function consists of two rubber lips, one axial and one radial, the space between these filled with grease, and the rotating seal case, which acts as an effective deflector due to the centrifugal force.

TURBO-pattern - Hydrodynamic sealing aids

TURBO is the Trelleborg Sealing Solutions designation of a range of hydrodynamic sealing aids supporting the sealing function. The hydrodynamic sealing aids are located on the air side of main sealing lip in the form of ribs or other geometrical figures of a variety of shapes. Optimum sealing conditions are attained when a thin film of lubricant is formed so that the lip does not come in contact with the sealing counterface. Such conditions are created by the TURBO-pattern, which brings about a pumping effect. The pumping effect starts at relatively low shaft speed, and is understood as the capacity of the seal lip to pump the medium to be sealed back from the air side to the medium side.



In order to avoid leakage at standstill or low speed, the TURBO-pattern includes a static edge, which provides a continuous contact line against the shaft. The frictional loss of the seals provided with TURBO-pattern is significantly lower than that caused by seals without hydrodynamic sealing aids. A lower friction does also allow higher shaft speeds, or provide longer service life.

The Turbo pattern is available in three versions: Bi-directional, left hand or right hand rotation. The standard is bi-directional as most applications have alternating movement of the hub or shaft. If an application has rotation in one direction only, the corresponding left or right hand type can be specified. The direction of rotation is always defined as seen from the air side.

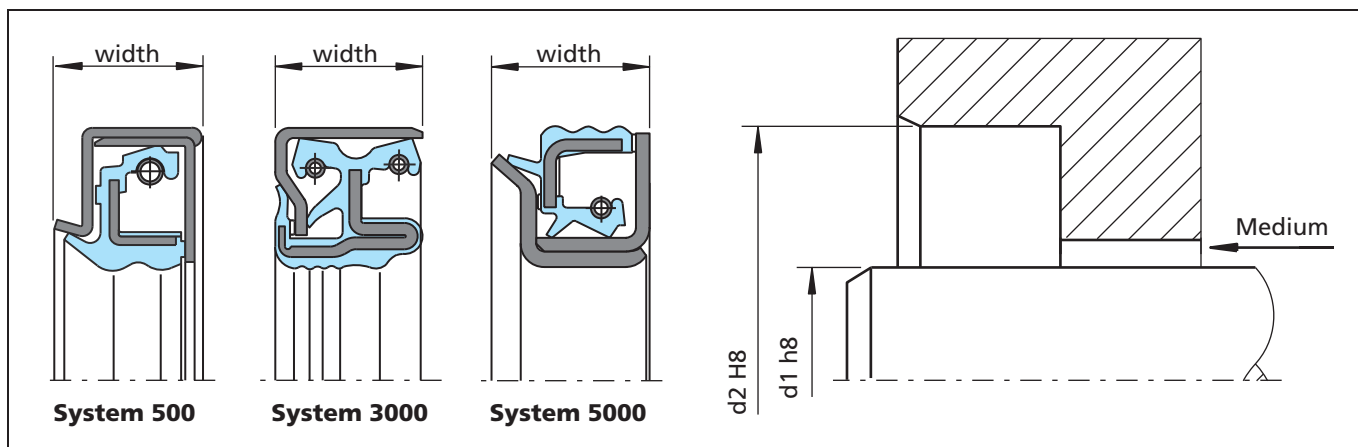

Figure 54 Installation drawing

Table XLII Standard dimensions

ID	OD	Width	System 500 (TC 5)			System 3000 (TC 3)			System 5000 (TC 0)		
			NBR	HNBR	FKM	NBR	HNBR	FKM	NBR	HNBR	FKM
85	140	17							X	X	X
90	130	17	X	X	X						
100	130	17	X	X							
100	140	17	X	X	X						
110	140	17	X	X	X						
111	146	17	X	X	X						
120	160	17	X	X	X						
125	160	17	X	X	X						
128	164	17	X	X	X						
130	160	17	X	X	X	X	X	X			
130	170	17	X	X	X						
135	165	17	X	X	X						
140	170	17	X	X	X						
143.3	190.5	16	X	X							
145	175	17	X	X	X						
149.9	176	16	X	X							
150	180	17				X	X	X			
155	190	17	X	X	X						
160	196	17	X	X							



Cassette Seal

ID d ₁	OD d ₂	Width	System 500 (TC 5)			System 3000 (TC 3)			System 5000 (TC 0)		
			NBR	HNBR	FKM	NBR	HNBR	FKM	NBR	HNBR	FKM
178	205	17	X	X	X						
187	230	17	X	X	X						
190	230	17	X	X	X						
320	360	19	X	X							

Table XLIII Materials

Standard material*	TSS material code	Standard metal case	Standard spring
NBR (75 Shore A)	4N063	Carbon steel	Carbon steel
HNBR (75 Shore A)	4H063		
FKM (75 Shore A)	4V063	Carbon steel	Carbon steel

* Special grades and other materials (ACM, EACM, VQM) on request.

Ordering example

Due to various combinations (HRV-additional dirt seal + coating), please contact your Trelleborg Sealing Solutions marketing company for ordering cassette seals.



■ Material

Metal case

The cases are normally stamped of cold rolled steel sheet, EN 10 130 - Fe P04. The high demands on the metal cases; high surface finish, free from scratches etc., calls for production in special tools.

Compression spring

For the spring, spring steel SS14 1774 - DIN 17223 - is normally employed. If resistance to corrosion is required, stainless steel SS 14 2331 - DIN 1.4301 - is used.

Sealing element

The material of the sealing element must be selected according to the working conditions of the seal and the environmental conditions.

Some of the requirements associated with environmental considerations are:

- good chemical resistance
- good resistance to heat and low temperature
- good resistance to ozone and weathering

The functional demands include:

- high resistance to wear
- low friction
- low compression set
- good elasticity

In addition, cost considerations make ease of process a desirable feature.

No material is available today, which satisfies all these requirements. The choice of material is therefore always a compromise between the relative significance of the factors involved.

Trelleborg Sealing Solutions has succeeded in developing a Nitrile Rubber compound (NBR), which exhibits good all-round properties, and for this reason it is the compound most commonly used.

The materials normally used for the sealing element are:

Nitrile Rubber (NBR), Hydrogenated Nitrile Rubber (HNBR) and Fluorinated Elastomers (FKM).

The additional dirt seal is normally made of Nitrile Rubber.

Nitrile Rubber is the basis material for cassette seals, as it covers most standard application requirements for general oil- and grease resistance. It is from function and cost aspects the best choice when temperature is not excessively high.

Nitrile can be used up to 125°C in non-aggressive oils. However for long term use, or in aggressive oils, service temperature is reduced to 80°C.

Nitrile generally has good mechanical properties and the material used for cassette seals is optimized for best heat and abrasion resistance.

Hydrogenated Nitrile Rubber is a further development of NBR, where the chemical double bonds in the polymer molecules are saturated with hydrogen. Since the double bonds of NBR are sensitive to heat and ozone, the HNBR will be superior to NBR in heat, ozone and weather resistance. It can generally be used up to 150°C in non-aggressive media, however for long term use maximum service temperature is 120°C.

The HNBR for the cassette seal is fully saturated and thus well suited for use in aggressive oils. The temperature should however be limited at 120°C. As saturated HNBR cannot be vulcanized with sulfur, the material has resistance to most hypoid oils up to about 120°C for long term use.

Low friction and high abrasion resistance are additional typical features.

Fluorinated Elastomers gives peak performance regarding heat and chemical resistance. They can be used up to 200°C for long term and are generally very resistant to oil, grease and fuels. Ozone and weather resistance is outstanding.

Mechanical and low temperature properties are however lower compared to Nitrile. Thus Fluoroelastomers should be considered only when the material properties are fully used. Some oil additives like amines and high pH-values may damage Fluoroelastomers, when used at high temperatures.

Temperature resistance

Increasing temperature accelerates the aging of rubber, the elongation decreases, and the compression set increases and finally the material becomes hard and brittle. Cracks at the sealing edge are a typical indication that the seal has been exposed to excessively high temperature. The aging of the rubber has appreciable significance on the useful life of the seal. It can generally be said that a temperature increase of 10°C (in air) will half the theoretical useful life of the rubber. Low temperatures are generally not a big problem since the seals themselves generate heat by friction when rubbing against another surface. If the seal has been chilled down, its original properties will return as soon as it is warmed up again. Some leakage may however arise during the start-up phase, before rubber material is softened by friction heat.



Cassette Seal

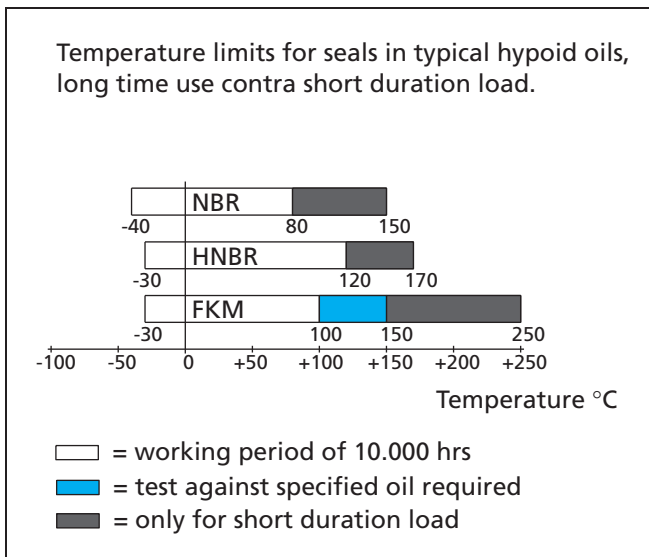

Figure 55 Temperature recommendations in typical hypoid oils

The temperature limits for the standard materials in hypoid oils are illustrated in figure above. They should only be regarded as approximate, since the oil type and the time of exposure also affect the materials. The temperature ranges within the shaded areas in the illustrations are temperatures that can be allowed only for certain periods of time. The higher the temperature, the shorter the period of time. At low temperatures, time has no influence on aging.

However, seals are not often working in air as only medium, but they are also affected by other media. Temperature limits in combination with other oils and media can be obtained from your local Trelleborg Sealing Solutions marketing company.

Oil resistance

Innumerable types of oils are available on the market and each of these has a different effect on the rubber. In addition, a given type of oil from different manufacturing may have a different influence.

The additives in the oil generally affect the rubber. This is the case with hypoid oil, which contains sulfur. Since sulfur is used as vulcanizing agent for Nitrile rubber, the sulfur

additive in the oil acts as a vulcanizing agent at temperatures above +80°C. As a result of this secondary curing, Nitrile rubber will rapidly become hard and brittle. Hydrogenated Nitrile and Fluorinated rubbers, which are not vulcanized with sulfur, can therefore be used for this type of oil, even though the operating temperature may not require these.

Oxidized oils represent another example illustrating the difficulty of tabulating the oil resistance of rubber materials. These oils are oxidized during operation and their properties will therefore change substantially.

Due to the above, no detailed information is given about resistance to certain types of oils. In case of questions or doubt, it is advisable to contact your local Trelleborg Sealing Solutions marketing company who have access to the many years of in-house testing made by FORSHEDA AB. Additional testing can be carried out in specific oil types provided a sufficient sample is available.

Chemical resistance

Since the Cassette seals are normally exposed to oil or grease, and not other chemicals, tables for chemical resistance to different media are not included. For guidelines about chemical resistance, please look under "Radial Oil Seals" or contact your local Trelleborg Sealing Solutions marketing company.

Application

System 500, 3000 and 5000

For the System 500, 3000 and 5000, requirements on the shaft finish and hardness are less stringent in comparison with traditional radial shaft seals. A simple fine turning operation gives an adequate surface on the shaft as well as for the housing bore. Diameter tolerances and finish values are shown in Figure 61 and 60.

As the sealing elements have built in counterfaces of their own, no wear on the shaft itself will occur and consequently no hardening of the shaft is necessary.

Suitable lead in chamfers facilitates the installation of the seal.

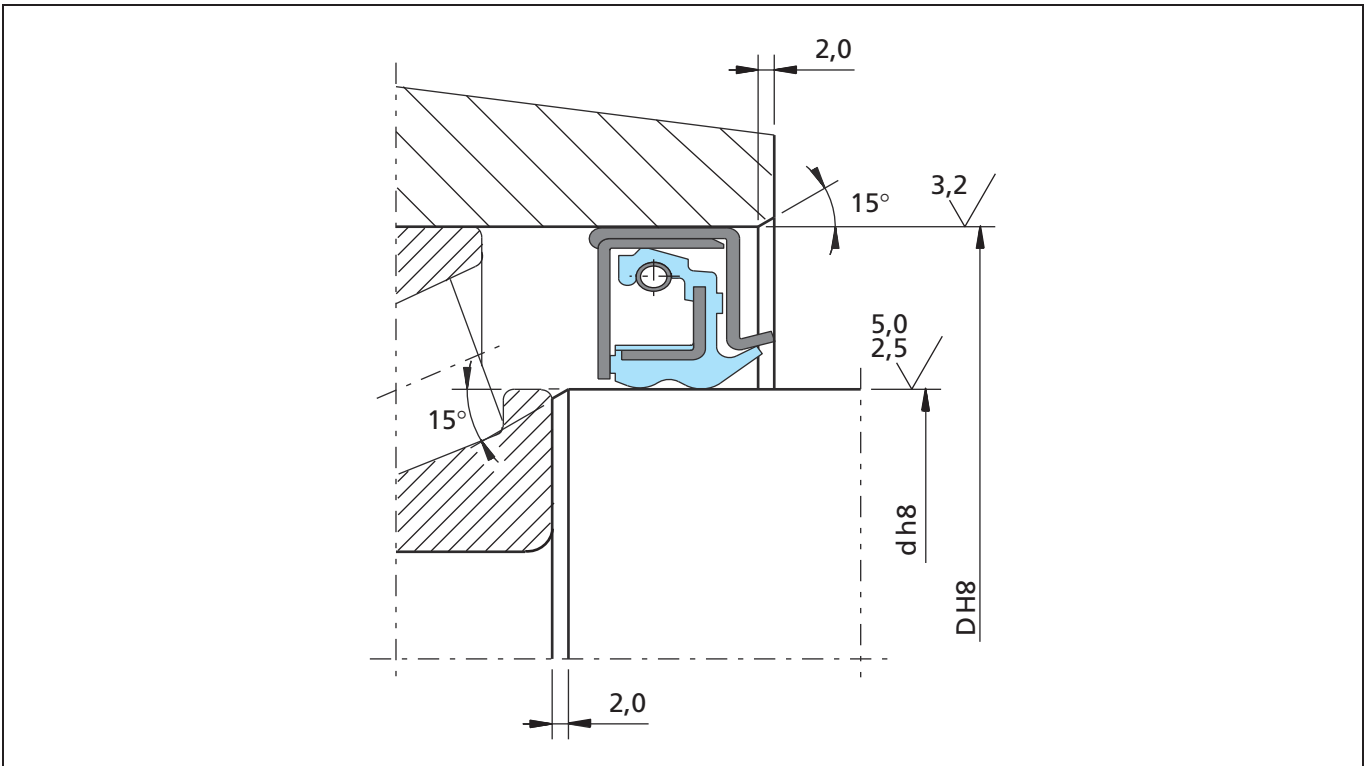

Figure 56 System 500 in wheel hub application

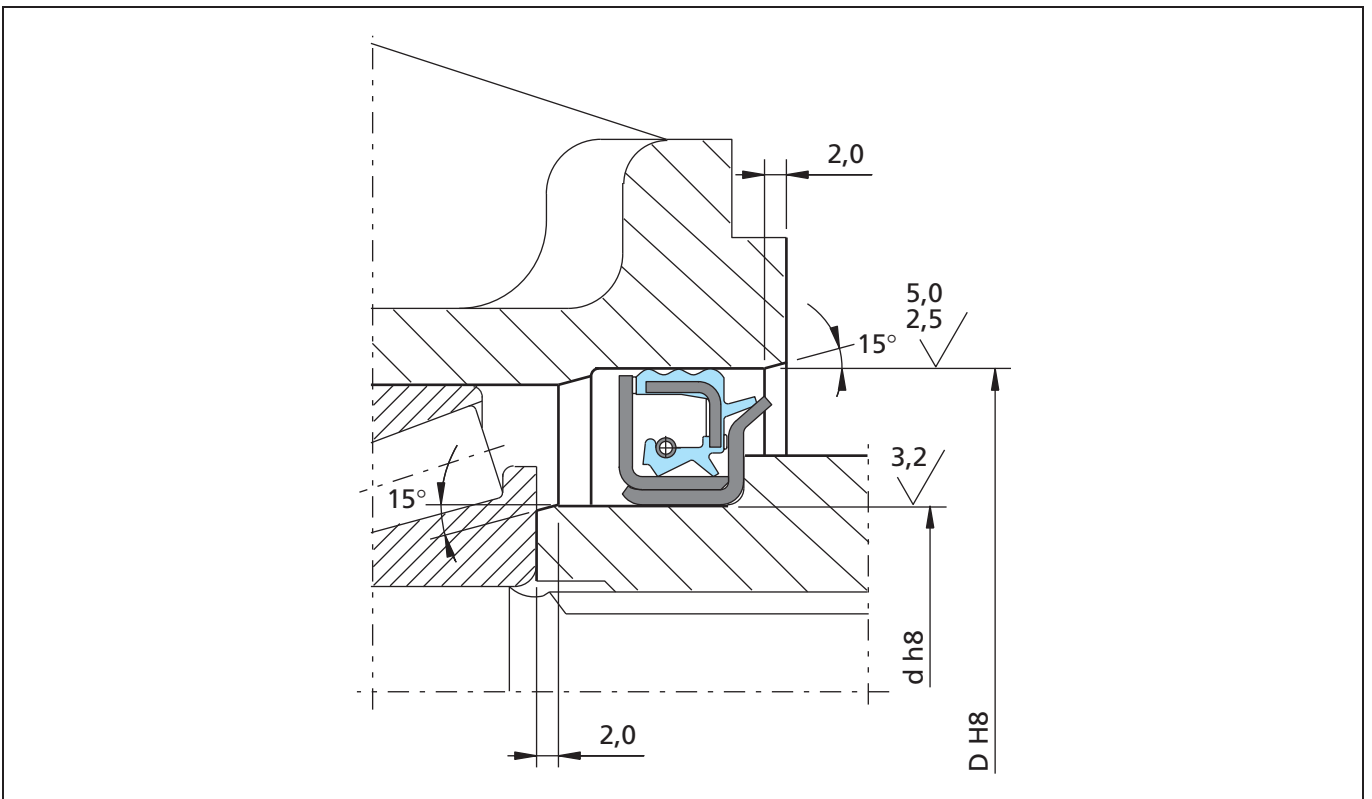

Figure 57 System 5000 in pinion application



Cassette Seal

Shaft run out

Shaft run out should as far as possible be avoided or kept within a minimum. At higher speeds there is a risk that the inertia of the sealing lip prevents it from following the shaft movement. The seal must be located next to the bearing and the bearing play is maintained at the lowest possible value.

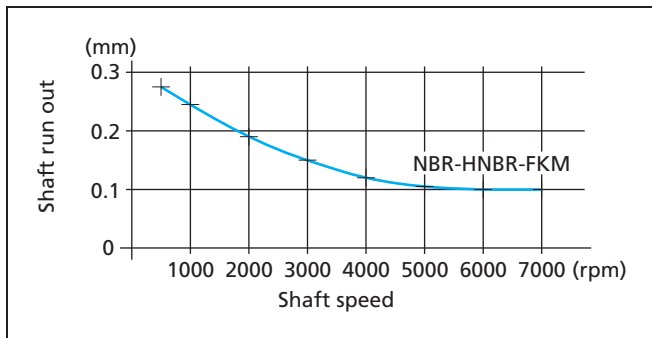

Figure 58 Permissible run out of the shaft

Eccentricity

Eccentricity between shaft and housing bore centers should be avoided in order to eliminate unilateral load of the lip.

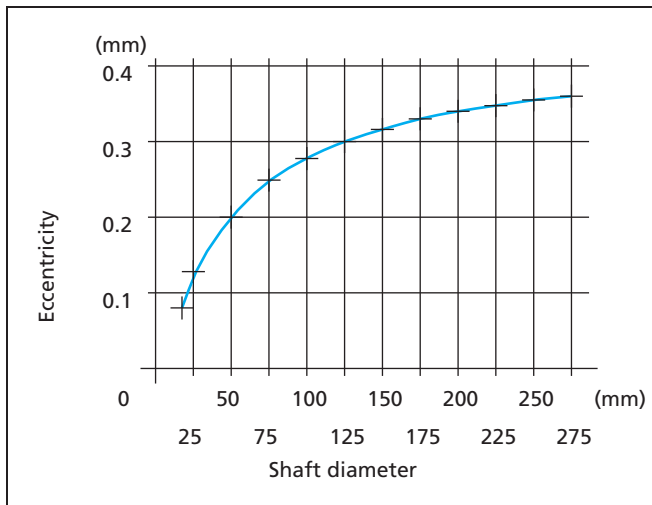

Figure 59 Permissible eccentricity

Shaft misalignment

Shaft misalignment should as far as possible be avoided or kept at a minimum, max. 0.25 mm.

Axial movement

Axial movement, inclusive what can be considered as normal bearing play, should be within ± 0.1 mm. The Cassette seal will function at larger movements, however this may cause a larger wear on support lugs and in the end shorter lifetime.

Pressure

Any difference in pressure from one side of the seal to the other should be avoided. Since the seal is developed for ventilated applications, a pressure difference will in the end lead to a decreased lifetime or leakage.

In some applications, a pressure difference up to 0.05 MPa could be accepted, but tests should be carried out for each case.

Speed

The permissible speed of rotation at sealing point for the various seal designs stated below, assumes normal running conditions, e.g. oil retention and no pressure differential across the seal.

Type of Seal	max. Surface Speed (m/s)
System 500	10
System 3000	4
System 5000	15

Start-/Operating torque

Due to transferred assembly forces inside the Cassette seal, the Cassette seal absorbs higher torque than a standard radial seal. See also the Installation part.

HRV - Additional dirt seal

The HRV seal is an all-rubber seal. It is designed for use as complementary seal for the System 500, in dirty applications such as off-road. The main sealing is against small particles such as dust, but also dirt and splash. Since the sealing action is axially, it can absorb some axial displacement.

The HRV seal is bonded directly to the outer case of the System 500. The design is similar to the FORSHEDA V-ring with a body and a flexible conical shaped sealing lip with an integral resilient "hinge".

The HRV seal rotates, due to the outer case being press fitted into the bore, and seals axially against a stationary counter face. During rotation the sealing lip rubs against the counterface under a contact pressure calculated to achieve a sealing function. The HRV seal also operates as a deflector ring, and its centrifugal action contributes to a good sealing function. Due to the centrifugal force, the contact pressure of the lip decreases with increase in speed. The contact pressure also varies with the fitted width.



The counterface for the HRV seal can consist of a suitable surface on the existing hardware or a steel casing adapted to suit the specification for the seal counterface.

The HRV seal:

- seals against outer medium like dirt and dust
- has a deflecting function due to the centrifugal force

The requirements on the counterface against which the sealing lip works are rather low. The requirements are more or less determined by the medium to be sealed. A finish-turned, polished surface with a surface roughness of Ra 1.6 to 2.0 μm is normally adequate. For sealing against liquid and dirt, Ra 0.8 to 1.6 μm is recommended. However, the character of the surface is of greater importance than the actual surface roughness value. For turned surfaces, it is recommended to buff the surface with fine emery cloth to remove any sharp peaks, which could tear the rubber surface apart and destroy the sealing function and shorten seal life time.

It is also necessary to ensure that the counterface is perpendicular to the shaft, flat and free from scratch marks and other damage within the sealing area. This is especially important when sealing fluids and fine particles.

To achieve the full effect of the deflector action, the HRV seal should be designed in a relatively open space.

The fitted width dimension will be stated on the corresponding product drawing.

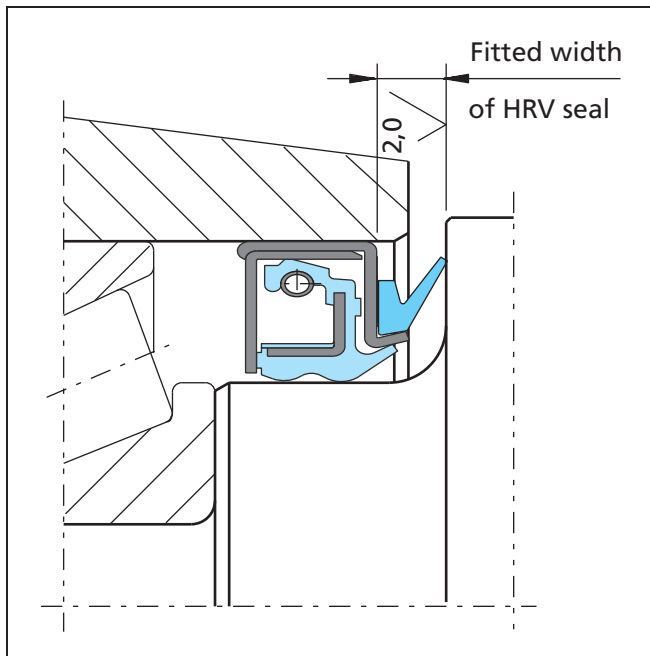

Figure 60 System 500 with HRV seal

■ Installation

As the Cassette Seal incorporates all functions as seal, shaft counterface and dust protection, there is no need for extra components such as exchangeable shaft sleeves or dirt protection.

This means fewer parts to stock and handle.

When handling and fitting traditional shaft seals there is always a risk of damaging the shaft surface or sealing lips and of improper installation. As the Cassette seal is fully enclosed the vital sealing components cannot be touched or damaged during the installation.

System 500 and System 3000

When the bearing has been installed the seal is simply pressed into the hub bore. The seal shall be oriented with the side marked "oil side" facing the interior of the hub. It is recommended to oil the inside rubber covered surface of the seal and also the shaft, to decrease the force necessary for assembly. If the Cassette seal is equipped with the additional dirt protection this shall be greased prior to fitting. The complete hub is then placed over the axle spindle. Normally the locking nuts for the bearing are used to drive the hub home. The Cassette seal automatically takes the right position on the shaft and no axial support is required provided no over pressure is built up during operation.

During the start-up phase, some leakage of grease as well as smoke formation may occur. This is a result of the generation of frictional heat between the metal cases and support lugs, and does not influence the function and service life of the seal.

If the seal has been misaligned during installation, or jammed against the bore, this may lead to the support lugs being too close to the metal case. This may mean the lugs are worn out or torn away at the start-up phase. The seal must in these cases always be replaced before start-up. When repairing of the wheel hub becomes necessary, a new seal shall always be installed.



Cassette Seal

System 5000

The System 5000 seal must be installed onto a shaft or a sleeve by a special assembly tool. The seal shall be oriented with the side marked "oil side" facing the inside of the gearbox. The shaft must then be assembled so the oil side of the seal is entering the housing bore.

If the shaft is hollow, the assembly tool should be designed with a guiding column.

For pinion applications on trucks, when a separate end carrier is used, the seal is simply pressed onto the end carrier in a first step of assembling. The end carrier is then entering the splines on the pinion shaft and then a locking nut is used to drive the end carrier and the seal into the right position.

The force required to assemble a System 5000 seal onto the shaft is between 20 to 50 kN, while assembly into the housing bore requires about 1.0 kN. The value of assembly force depends on surface structure for shaft resp. housing bore as well as the tolerances. It is recommended to oil the outer rubber covered surface of the seal and also the housing bore, to decrease the force necessary for assembly.

During the start-up phase, eventually some leakage of grease and smoke formation may occur. This is a result of the generation of frictional heat between the metal cases and the support lugs of rubber, and does not influence on the function and service life of the seal.

If the seal is jammed or damaged in some way during installation, the seal must be replaced before start up.

If the construction is disassembled for any reason, a new seal should be installed.

Further instructions for assembling can be found on separate assembly instruction sheets available from your local Trelleborg Sealing Solutions marketing company.

Dismantling and replacement

As all the necessary functions are integrated in the Cassette seal the complete sealing arrangement is renewed. The shaft to be sealed is unaffected by wear and once it has been cleaned and possible corrosion and dirt have been removed a new seal can be fitted again.

The Cassette Seal may be provided with a sealant on the metal casing when it is installed into the housing. Take care that the sealant do not flow into the seal or is smeared onto the rubber surface, as this may impede the function of the seal. The sealant can reduce the risk of static leakage due to small imperfections on the surface.

Storage

As the service life of bearings and other machine parts depends on how well the seals perform, seals should be handled with caution. Unfavorable storage conditions or improper handling will most likely lead to a change of their physical properties. This can lead to a shortening of life, or failure, for example as a result of hardening or softening, cracking or other surface damages. These changes can be the result of one particular factor or a combination of factors, like oxygen, ozone, heat, light, moisture, solvents etc. Storing the seals under load can lead to permanent deformation of the elastomer. On the other hand, properly stored elastomer products retain their properties for several years.

As the sensitive sealing lips and counter faces are well protected inside the Cassette seal casing, there is less risk of mechanical damages and influence of dirt and dust in comparison to many other seal types.

Cleaning

If cleaning of Cassette seals is necessary, use a damp duster and allow the seals to dry off at room temperature.

Solvents, sharp-edged objects and abrasives should not be used.

V-Ring







■ V-RING

■ General

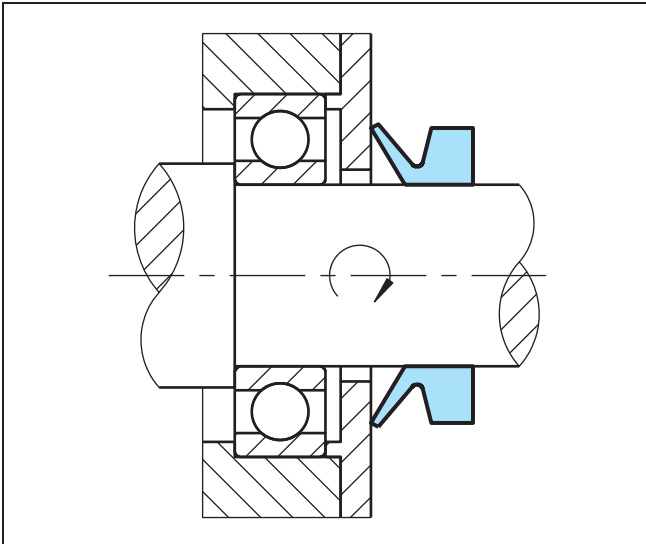

Figure 61 Method of operation of the V-Ring

The V-RING is a unique all-rubber seal for rotary shafts. Developed in the 1960's by FORSHEDA AB, it has been used successfully by OEMs and on the replacement market world wide in a broad range of applications.

The V-Ring is the perfect seal to prevent the ingress of dirt, dust, water or combinations of these media while positively retaining grease. With its unique design and performance the V-Ring can be used with a wide range of bearing types. It can also be used as a secondary seal to protect primary seals that do not perform well in hostile environments.

Description and advantages

The V-Ring is normally stretched and mounted directly on the shaft, where it is held in position by the inherent tension of the rubber body. It rotates with the shaft and seals axially against a stationary counterface, perpendicular to the shaft. The counterface can be the side wall of a bearing or a washer, stamping, bearing housing, or even the metal case of an oil seal. The sealing lip is flexible and applies only a relatively light contact pressure against the counter-face and yet is still sufficient to maintain the sealing function. The low contact pressure (that varies with the fitted width) allows the seal to run dry in many applications.

Due to influence of the centrifugal force, the contact pressure of the lip decreases with increased speed. This means that frictional losses and heat are kept to a minimum, resulting in excellent wear characteristics and

extended seal life. Once breakaway friction is overcome, the friction reduces steadily until around the 10 - 15 m/s range, when it reduces quite quickly. In the 15 - 20 m/s range the friction reduces to zero. The V-Ring then serves as a clearance seal and deflector. The power loss due to seal friction develops as shown in Fig. 62.

The flexible lip and hinge allow the V-Ring to function even in the presence of a certain amount of run-out, eccentricity and shaft misalignment. Contact our local Trelleborg Sealing Solutions marketing company for advice on these and other application issues.

V-Rings are made entirely of rubber without fabric or sheet metal reinforcement. They are, therefore, particularly easy to install. V-Rings can be stretched and, depending on size, installed over flanges, pulleys and bearing housings without costly dismantling. For larger sizes they can even be supplied as cut rings and joined by vulcanization on site.

Design

V-Rings are available in seven standard cross-sections to meet various space and application requirements.

The cross-sections of profiles A and S increase with the shaft diameter, whilst the other types have the same cross-section for the whole diameter range.

Profile A is the most common and available for shaft diameters from 2.7 to 2020 mm, inclusive.

Profile S is wide and tapered, which provides a very firm hold on the shaft. The rings are available for shaft diameters from 4.5 to 210 mm.

Profiles L and LX have narrow axial cross sections making them suitable for compact arrangements and are often used in combination with labyrinth seals. Available for shaft diameters from 105 (135 for LX) to 2025 mm.

Profiles RME, RM and AX are heavy duty V-Rings that are designed primarily for large high speed bearing arrangements, i.e. rolling mill and papermaking machine applications. Additionally they can be used as secondary seals for heavy duty applications where the primary seal has to be protected against water and or particulate contamination. The RME, RM and AX types can be axially and radially located on the shaft with specially designed clamping bands (see page 166). Available for shaft diameters from 300 mm and up.

Larger V-Ring sizes are available as spliced seals. For more details please contact your local Trelleborg Sealing Solutions marketing company.



V-Ring

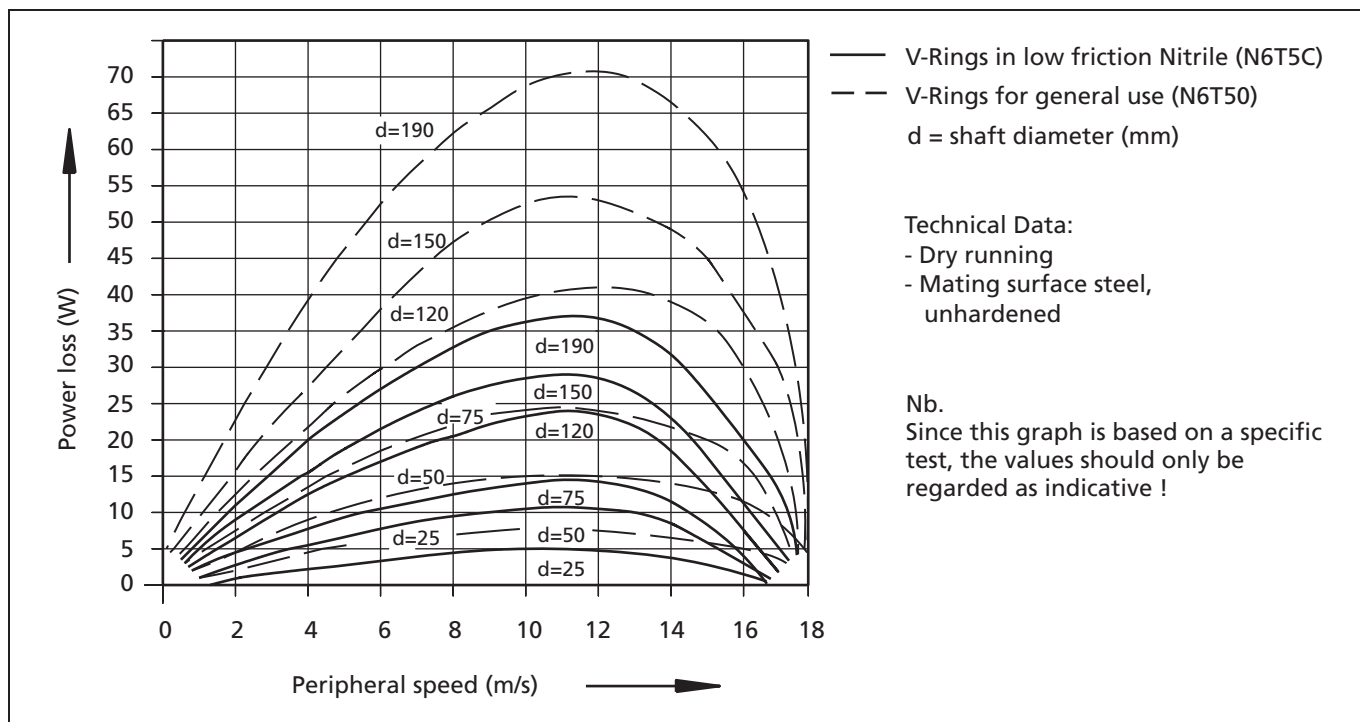

Figure 62 Power loss as a function of peripheral speed for various sizes

Materials

When selecting the correct rubber compound it is necessary to take the following requirements into account;

- good chemical resistance
- good resistance to high and low temperatures
- good resistance to ozone and weathering

It is also necessary to consider the need for the following attributes;

- high resistance to wear
- low friction
- low compression set
- good elasticity

Material types

The most frequently selected material is the purpose made Nitrile rubber N6T50 which has excellent all round properties.

For applications with temperatures above 100°C, or in chemically aggressive conditions, V-Rings made of fluorinated rubber (FKM) can be supplied. In fact a wide range of rubber compounds is available and some of these are listed below.

Table XLIV Guide to selection of rubber material

TSS code	Old (FORSHEDA) code	Type of rubber	Characteristics
N6T50	NBR 510	Nitrile	For general use
N7T50	NBR 555	Nitrile	Heavy duty conditions. Good tear and abrasion resistance
N6T5C	NBR 562	Nitrile	Low friction
H7T50	HNBR 576	Hydrogenated Nitrile	Hypoid oils at high temp.
CDT50	CR 415	Chloroprene	For applications in the presence of ozone
E7T50	EPDM 762	Ethylene-Propylene	Good weather and ozone resistance, used with special chemicals such as acetone, ammonium carbonate and benzaldehyde
VDT50	FKM 900	Fluorinated	Very high temperature and chemical resistance



Temperature resistance

Exposure to higher temperatures accelerate the aging of rubber, the elongation decreases, the compression set increases, and finally the material becomes hard and brittle. Cracks at the sealing edge are a typical indication that the seal has been exposed to excessively high temperature. The aging of the rubber has an appreciable negative influence on the useful life of the seal.

The temperature limits for the principal materials are illustrated in Figure 63. They should only be regarded as approximate, since the media and time of exposure also affect the materials.

The temperature ranges within the shaded areas indicate temperatures that can be allowed for only certain periods of time. The higher the temperature, the shorter the service life. If the maximum temperature is exceeded, the elastomer may suffer permanent set or damage. Special elastomers are available for use in cold temperatures. If the elastomer is subjected to temperatures lower than the recommended values it will become hard and brittle, however it will regain its properties as soon as the temperature rises again.

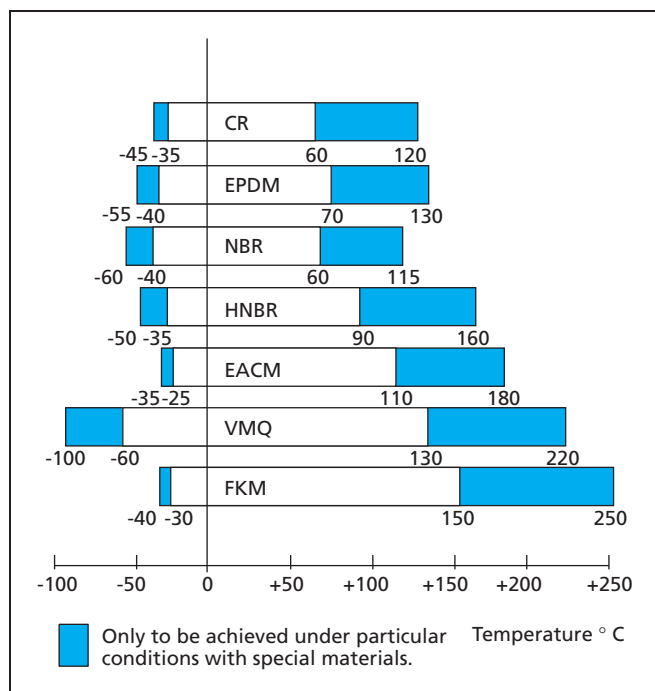

Figure 63 Temperature recommendations for V-Rings

Oil and solvent resistance

Since the V-Ring is used primarily for sealing grease lubricated bearings exposed to water splash, dirt, dust, scale etc. the normal choice of compound is Nitrile Rubber (N6T50) 510. However innumerable types of oil are available on the market and each of these has different effect on rubber. In addition, a given type of oil from different manufacturers may have different influence.

It is the additives in the oil that may affect the rubber. Especially so for hypoid oils, that contain sulfur. Since sulfur is used as the vulcanizing agent for Nitrile rubber it will initiate a secondary curing at temperatures above +80°C. As a result of that, Nitrile rubber will become hard and brittle. Hydrogenated Nitrile and Fluorinated rubbers, which are not vulcanized with sulfur, may therefore be considered for use with this type of oil. Oxidized oils represent another example illustrating the difficulty of tabulating the oil resistance of rubber materials. These oils are oxidized during operation and their properties will therefore change substantially. Such oils break down silicone rubber. Solvents could generally cause deterioration or swelling of the rubber however mixtures of different solvents may cause considerably more damage than a single solvent. An example of this is mixing methanol and hydrocarbons.

For further information on oil and solvent resistance we recommend you to be in contact with your local Trelleborg Sealing Solutions marketing company.

Application instructions

The V-RING is normally fully exposed to the medium to be sealed. The requirements on the shaft and the counterface are mainly dependent on the medium and the peripheral speed.

Shaft design

The V-Ring is in most cases fitted on a rotating shaft. The requirements regarding diameter tolerances and surface roughness of the shaft are fairly moderate. As the V-Ring is an all-rubber seal it can be stretched to a varying degree and be used for a wide range of shaft diameters.

In applications where low power loss and long lifetime are important it is recommended that the V-Ring size is selected, so that the shaft diameter falls between the minimum and nominal values within the recommended range. This is because the contact pressure of the sealing lip increases with the shaft diameter, due to the stretch of the V-Ring. At a higher stretch, a harder contact pressure is generated, causing an accelerated wear of the sealing lip. In order to prevent the V-Ring from sliding along the shaft, and to ensure the correct installation width, it is always recommended to arrange an axial support, especially for small cross-section profiles and larger shaft sizes, for example V-Ring type A, L and LX.



V-Ring

The surface roughness of the shaft should in general not exceed Ra 6.3 µm. For sealing fluids and fine particles, a maximum of Ra 3.2 µm is recommended. Sharp edges and burrs, which can damage the V-Ring must be avoided.

Counter-face design

The condition of the counter-face has a great influence on the sealing function. The medium to be sealed and the peripheral speed of the shaft determine the requirements regarding surface roughness and material of the counter-face. It is important that it is smooth and flat without any sharp edges. To achieve the full effect of the flinger action, the V-Ring should always be designed in a relatively open space. Equally important is to keep the gap between the shaft and the counter-face as small as possible, in order to prevent entry of the V-Ring lip during the installation. Recommended application dimensions are given in the dimension tables.

Material and material hardness

Cold rolled steel sheet, stainless steel or zinc plated sheet are excellent materials for the counter-face. However, the choice of material is highly dependent on the medium to be sealed.

For normal running conditions, conventional mild steel with a hardness of min. 125 HB is sufficient. For sealing against grease, oil and dry particles no further surface treatment is required. With an increase in speed and the presence of abrasive particles the hardness of the counter-face must also be increased.

The following materials are normally used :

Material	Hardness HB	Medium
Mild Steel	125-150	Water splash, sand, dust
Grey Cast Iron	190-270	Water splash, sand, dust
Sinter Bronze	100-160	Water, dust
Stainless Steel (Cr/Ni 18-8, C 0.1%)	150-200	Water
Stainless Steel (Cr/Ni 18-8, C 0.15%)	350	Water and abrasive particles
Work-hardened		
Acid Proof Steel	180-200	Chemicals
Tungsten Carbide	350-500	Water and scale
Forged Steel	200-255	Water and scale
Die-cast Aluminum	90-160	Water splash

Surface treatment

When the counter-face is exposed to water or other corrosive media, it must be protected accordingly.

Mild steel surfaces should either be zinc-plated and chromated, chromium plated, treated with an anticorrosion spray, or painted. The choice of treatment will depend on the overall running conditions.

Where the seal is immersed in water, stainless steel is recommended. However, due to the poor thermal conductivity of stainless steel it should not be used in dry running conditions unless the speed is slow (<1 m/s).

Surface finish

The rate of abrasion of the V-Ring is influenced by a number of factors, one of which is the surface finish of the counter-face. The choice of surface finish will depend on the medium to be sealed and the shaft speed as well. It is not only the surface finish value as such that is important, but also the surface character. For turned surfaces, it is recommended to buff the surface with fine emery cloth to remove any sharp peaks arising from the turning operation.

Surfaces with too fine finish, e.g. certain cold rolled steel surfaces, may cause a suction effect between the V-Ring lip and the counter-face resulting in noise problems and uneven running (so-called stick-slip effect).

The counterface surface must be free from scratch marks and other surface damages within the sealing area. This is important when sealing fluids and fine particles are present.

Guide to recommended surface finish

Surface finish µm Ra	Speed m/s	Medium
0.4-0.8	> 10	Oil, water, scale, fiber
0.8-1.6	5-10	Oil splash, grease, water splash
1.6-2.0	1-5	Grease, dust, water splash, scale
2.0-2.5	<1	Grease, dust

The surface finish should not be lower than Ra 0.05 µm.

Flatness

The flatness of the counter-face is of importance, especially at higher shaft speeds.

The maximum permissible flatness deviation is normally defined as 0.4 mm per 100 mm.



■ Installation

Axial support

When used to retain oil and grease, an axial support for the V-Ring is always required. For applications with a lower degree of stretch than recommended in the dimension tables (e.g. for ease of assembly) or with a shaft speed exceeding 6-8 m/s (depending on the rubber compound selected) an axial support is also necessary.

An axial support can ensure that the correct installation width relative to the counter-face is maintained for blind assemblies.

The V-Ring must always be supported over its entire base. The axial support should be designed in accordance with Figure 64. The dimensions A, c, d₁, d₃ and B₁ are shown in the dimension tables.

Calculation of the axial support diameter d₅ is as follows;

V-Ring type	Diameter d ₅
A, S	$d_1 + 0.5 \times c$
L, LX	$d_1 + 3 \text{ mm}$
RM, RME	$d_1 + 10 \text{ mm}$
AX	$d_1 + 9 \text{ mm}$

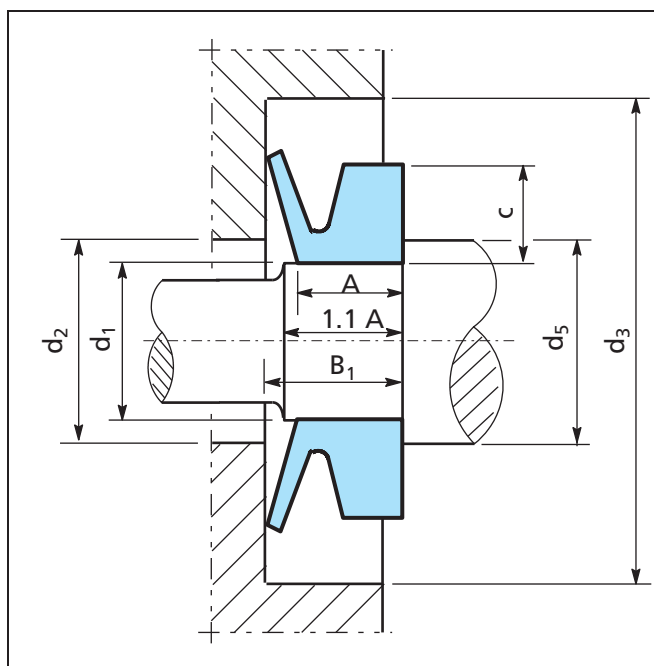

Figure 64 Axial support

Radial retention

When the V-Ring is fitted on the shaft, the body of the V-Ring is subject to a centrifugal force and tends to move or even lift off from the shaft at a certain speed.

At shaft speeds over 10-12 m/s, depending on the V-Ring material, the V-Ring in general requires radial retention.

The speed when radial retention is required is also dependent on the degree of stretch of the V-Ring. V-Rings larger than 2000 mm should always be fitted with radial retention, irrespective of the operating speed.

The radial retention can be designed as a recess, in which the V-Ring body fits, or consist of a number of separate clamping segments. Please contact your local Trelleborg Sealing Solutions marketing company for further guidance.

The clamping band type A or RM are other useful alternatives. See page 166.

Stationary assembly

In cases where the peripheral speed of the shaft exceeds 10-12 m/s an alternative method to radial clamping is to mount the V-Ring on a stationary component in the unit. The contact pressure of the lip will remain constant, as there will be no centrifugal force acting upon the lip.

In comparison to a rotating V-Ring, friction and power loss will be higher resulting in somewhat shorter service life. In order to compensate for this the following steps should be taken:

Counter-face surface finish:
machine to max. 0.8 μm Ra

V-Ring stretch:
maximum 4-6%

Axial interference:
keep to the minimum requirements for compensation of the axial movement within the assembly.

At higher peripheral speed adequate lubrication and heat transfer from the counter-face are required.

Torque

The torque, and consequently the power loss due to the friction of the seal, is often of such a magnitude that it should be taken into consideration when deciding seal type. This applies particularly in the case of small electrical motors, conveyor rollers or any unit where low friction is an important requirement.

The power losses are influenced by many factors such as the seal design and compound, surface finish of the counter-face, fitted width and stretch, speed, medium, lubricant, temperature etc.



For this reason it is difficult to give exact torque values for all running conditions.

Generally speaking, the power losses resulting from a V-Ring are always lower than a corresponding radial oil seal.

Grease lubrication gives higher power losses than oil lubrication or dry running.

By applying a suitable low friction dry film lubricant on the counter-face surface the friction and the heat generated can be reduced.

An increase of the fitted width of the V-Ring, giving a reduced lip pressure, will also lower the friction. However, the total axial movement in the assembly must be considered in order not to exceed the tolerances shown in the dimension tables.

Whenever detailed information about power losses is required, consult your local Trelleborg Sealing Solutions marketing company.

Installation guidelines

When the V-Ring is used as a grease seal/contaminant excluder, the V-Ring is normally mounted on the outside of a bearing housing, with or without, axial support.

General rules:

1. The V-Ring, the counter-face and the shaft should be clean.
2. The shaft should preferably be dry and free from grease or oil, particularly when the V-Ring is mounted without axial support.
3. The lip of the V-Ring should be lubricated with a thin film of grease or silicone oil.
4. In cases when friction must be reduced to a minimum, coat the counter-face with a low friction agent, and do not apply grease to the lip.
5. Ensure that the V-Ring is mounted with a uniform stretch around the shaft.

When the V-Ring is mounted on the shaft the outer diameter of the lip is reduced. Unless the stretch is uniform this reduction will vary around the periphery. This may lead to partial entry of the lip in the bore of the counter-face when the seal is pushed into position.

In the case of large diameter seals a uniform stretch can be achieved by inserting a blunt screwdriver or a piece of string under the V-Ring body and running it around the shaft twice. Take care not to damage seal or shaft.

The most convenient method of assembling large diameter V-Ring's, to ensure uniform stretch, is to mark off the body of the V-Ring and the shaft or seating with six equidistant marks. The marks should then be matched together when the V-Ring is fitted in position.

For more detailed installation instructions, contact your local Trelleborg Sealing Solutions marketing company.

Clamping band

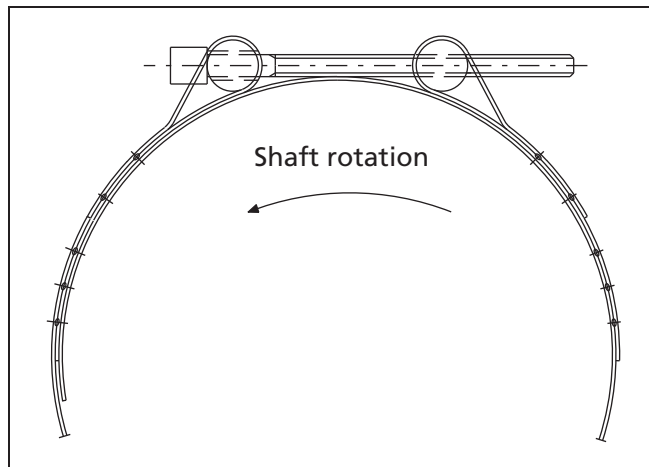

Figure 65 Clamping band RM

FORSHEDA Clamping Band RM

For clamping large diameter V-Rings of the RM and RME types, the FORSHEDA Clamping Band RM is recommended.

Together with Clamping Band RM a special series of "low stretch" V-Rings can be used for shaft diameters larger than 1500 mm. This will reduce torque and facilitate the fitting of the V-Ring.

When ordering the Clamping Band RM, simply state the shaft diameter for which the clamping band is intended. Each clamping band is comprised of a set of standard lengths measuring 1000 mm and 1500 mm depending on the size, standard attachments and, if necessary, an adjustable length and two set of rivets. When the parts are assembled, the clamping band will fit the specific V-Ring.

All parts are made of acid-proof steel with the exception of the pop rivets, which are made of conventional stainless steel. If operation conditions dictate the use of acid-proof steel, the conventional rivets must be used in conjunction with the adjustable length.



Fitting the clamping band RM

Trim the adjustable clamping band to the right length by using a pair of shears. Rivet the adjustable length and the end attachment together by using a standard pop riveter and the three pop rivets.

Locate the V-Ring in correct position relative to the counterface, i.e. the predetermined B₁-dimension.

Smear the V-Ring with a thin film of grease in the groove designed for the clamping band.

Using the attachments supplied with the band sections, join them together and position the complete band in the body groove with the screw heads facing the direction of shaft rotation. Turn the attachment screws a few turns one by one until the band is tight.

Check that the entire band fits snugly in the body groove.

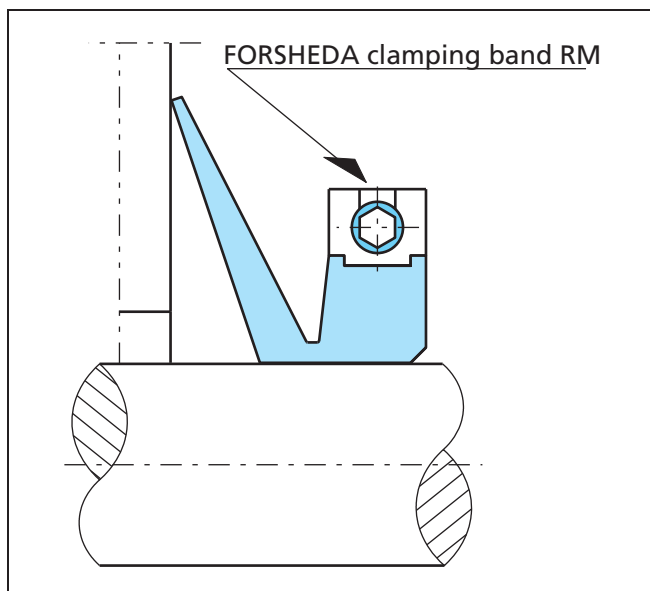

Figure 66 FORSHEDA clamping band RM

Clamping band for V-Ring type A and AX

The clamping band A/AX is meant to be used with V-rings type A and AX on shaft diameters from 200mm and larger. The clamping band keeps the V-ring in position both axially and radially and can be re-used several times. The clamping band is supplied in 5m lengths. Screw joints to connect the clamping band as well as the buckle are ordered on separate article number. The band is made of stainless steel AISI 301, the screw joint is made of AISI 304 with galvanized screw.

To order the right size and for the correct installation, please ask for the "TECH INFO".

TSS part numbers for clamping band A

Band	XZYDFAE002
Screw joint	XZYDF00022
Buckles	A(AX)XZYDFAR001

Splicing by vulcanization

To avoid unnecessary downtime and difficult dismantling when carrying out preventive maintenance of process machinery, it is possible to split the V-Ring, fold it around the shaft and splice it.

The V-Ring can be supplied either as a complete ring and cut on site, or supplied in the split condition from the factory. For V-Rings types RM and RME it is preferable to split the seals at the factory due to the size of the section.

The best method of splicing a V-Ring is by vulcanizing. Portable vulcanizing tools for the different V-Rings profiles, vulcanizing cement and detailed instructions are available from your local Trelleborg Sealing Solutions marketing company.



■ Dimension table - V-Ring type A

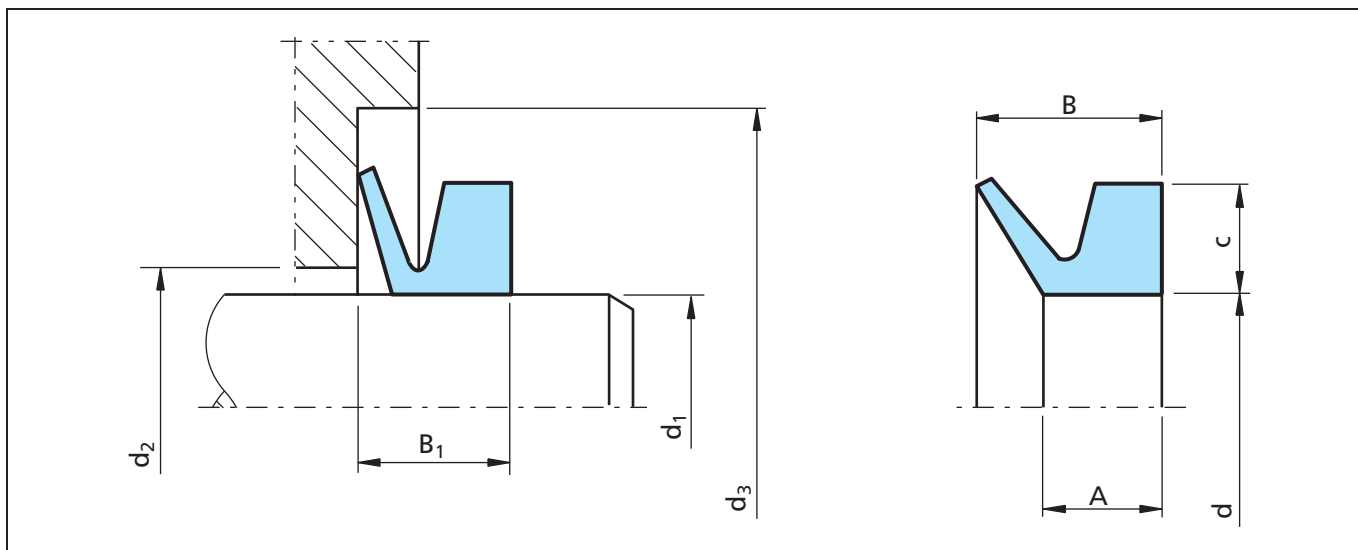

Figure 67 Installation drawing

When the shaft diameter d_1 is on the boundary between two sizes of V-Ring, select the larger V-Ring.
All dimensions in mm.

Ordering example

V-Ring, type A
for shaft diameter = 30.0 mm
Material: N6T50 (Nitrile Elastomer)

TSS Article No.	TWVA00300	-	N6T50
TSS Part No.			
Quality index (standard)			
Material no. (standard)			
Corresponding to FORSHEDA ref. V-30A NBR510			

Table XLV Profile dimensions - assembly dimensions

For shaft diameter d_1	Inside dia. d	Height of cross-section c	Dimension A	Free width B	Maximum d_2	Minimum d_3	Fitted width B_1	V-Ring FORSHEDA Ref.	TSS Part No.
2.7 - 3.5	2.5	1.5	2.1	3.0	$d_1 + 1$	$d_1 + 4$	2.5 ± 0.3	V-3A	TWVA00030
3.5 - 4.5	3.2	2	2.4	3.7	$d_1 + 1$	$d_1 + 6$	3.0 ± 0.4	V-4A	TWVA00040
4.5 - 5.5	4	2	2.4	3.7	$d_1 + 1$	$d_1 + 6$	3.0 ± 0.4	V-5A	TWVA00050
5.5 - 6.5	5	2	2.4	3.7	$d_1 + 1$	$d_1 + 6$	3.0 ± 0.4	V-6A	TWVA00060

V-Ring



For shaft diameter d_1	Inside dia. d	Height of cross-section c	Dimension A	Free width B	Maximum d_2	Minimum d_3	Fitted width B_1	V-Ring FORSHEDA Ref.	TSS Part No.
6.5 - 8.0	6	2	2.4	3.7	$d_1 + 1$	$d_1 + 6$	3.0 ± 0.4	V-7A	TWVA00070
8.0 - 9.5	7	2	2.4	3.7	$d_1 + 1$	$d_1 + 6$	3.0 ± 0.4	V-8A	TWVA00080
9.5 - 11.5	9	3	3.4	5.5	$d_1 + 1$	$d_1 + 9$	4.5 ± 0.6	V-10A	TWVA00100
11.5 - 12.5	10.5	3	3.4	5.5	$d_1 + 1$	$d_1 + 9$	4.5 ± 0.6	V-12A	TWVA00120
12.5 - 13.5	11.7	3	3.4	5.5	$d_1 + 1$	$d_1 + 9$	4.5 ± 0.6	V-13A	TWVA00130
13.5 - 15.5	12.5	3	3.4	5.5	$d_1 + 1$	$d_1 + 9$	4.5 ± 0.6	V-14A	TWVA00140
15.5 - 17	14	3	3.4	5.5	$d_1 + 1$	$d_1 + 9$	4.5 ± 0.6	V-16A	TWVA00160
17.5 - 19	16	3	3.4	5.5	$d_1 + 1$	$d_1 + 9$	4.5 ± 0.6	V-18A	TWVA00180
19 - 21	18	4	4.7	7.5	$d_1 + 2$	$d_1 + 12$	6.0 ± 0.8	V-20A	TWVA00200
21 - 24	20	4	4.7	7.5	$d_1 + 2$	$d_1 + 12$	6.0 ± 0.8	V-22A	TWVA00220
24 - 27	22	4	4.7	7.5	$d_1 + 2$	$d_1 + 12$	6.0 ± 0.8	V-25A	TWVA00250
27 - 29	25	4	4.7	7.5	$d_1 + 2$	$d_1 + 12$	6.0 ± 0.8	V-28A	TWVA00280
29 - 31	27	4	4.7	7.5	$d_1 + 2$	$d_1 + 12$	6.0 ± 0.8	V-30A	TWVA00300
31 - 33	29	4	4.7	7.5	$d_1 + 2$	$d_1 + 12$	6.0 ± 0.8	V-32A	TWVA00320
33 - 36	31	4	4.7	7.5	$d_1 + 2$	$d_1 + 12$	6.0 ± 0.8	V-35A	TWVA00350
36 - 38	34	4	4.7	7.5	$d_1 + 2$	$d_1 + 12$	6.0 ± 0.8	V-38A	TWVA00380
38 - 43	36	5	5.5	9.0	$d_1 + 2$	$d_1 + 15$	7.0 ± 1.0	V-40A	TWVA00400
43 - 48	40	5	5.5	9.0	$d_1 + 2$	$d_1 + 15$	7.0 ± 1.0	V-45A	TWVA00450
48 - 53	45	5	5.5	9.0	$d_1 + 2$	$d_1 + 15$	7.0 ± 1.0	V-50A	TWVA00500
53 - 58	49	5	5.5	9.0	$d_1 + 2$	$d_1 + 15$	7.0 ± 1.0	V-55A	TWVA00550
58 - 63	54	5	5.5	9.0	$d_1 + 2$	$d_1 + 15$	7.0 ± 1.0	V-60A	TWVA00600
63 - 68	58	5	5.5	9.0	$d_1 + 2$	$d_1 + 15$	7.0 ± 1.0	V-65A	TWVA00650
68 - 73	63	6	6.8	11.0	$d_1 + 3$	$d_1 + 18$	9.0 ± 1.2	V-70A	TWVA00700
73 - 78	67	6	6.8	11.0	$d_1 + 3$	$d_1 + 18$	9.0 ± 1.2	V-75A	TWVA00750
78 - 83	72	6	6.8	11.0	$d_1 + 3$	$d_1 + 18$	9.0 ± 1.2	V-80A	TWVA00800
83 - 88	76	6	6.8	11.0	$d_1 + 3$	$d_1 + 18$	9.0 ± 1.2	V-85A	TWVA00850
88 - 93	81	6	6.8	11.0	$d_1 + 3$	$d_1 + 18$	9.0 ± 1.2	V-90A	TWVA00900
93 - 98	85	6	6.8	11.0	$d_1 + 3$	$d_1 + 18$	9.0 ± 1.2	V-95A	TWVA00950
98 - 105	90	6	6.8	11.0	$d_1 + 3$	$d_1 + 18$	9.0 ± 1.2	V-100A	TWVA01000
105 - 115	99	7	7.9	12.8	$d_1 + 4$	$d_1 + 21$	10.5 ± 1.5	V-110A	TWVA01100
115 - 125	108	7	7.9	12.8	$d_1 + 4$	$d_1 + 21$	10.5 ± 1.5	V-120A	TWVA01200
125 - 135	117	7	7.9	12.8	$d_1 + 4$	$d_1 + 21$	10.5 ± 1.5	V-130A	TWVA01300
135 - 145	126	7	7.9	12.8	$d_1 + 4$	$d_1 + 21$	10.5 ± 1.5	V-140A	TWVA01400



V-Ring

For shaft diameter d_1	Inside dia. d	Height of cross-section c	Dimension A	Free width B	Maximum d_2	Minimum d_3	Fitted width B_1	V-Ring FORSHEDA Ref.	TSS Part No.
145 - 155	135	7	7.9	12.8	$d_1 + 4$	$d_1 + 21$	10.5 ± 1.5	V-150A	TWVA01500
155 - 165	144	8	9.0	14.5	$d_1 + 4$	$d_1 + 24$	12.0 ± 1.8	V-160A	TWVA01600
165 - 175	153	8	9.0	14.5	$d_1 + 4$	$d_1 + 24$	12.0 ± 1.8	V-170A	TWVA01700
175 - 185	162	8	9.0	14.5	$d_1 + 4$	$d_1 + 24$	12.0 ± 1.8	V-180A	TWVA01800
185 - 195	171	8	9.0	14.5	$d_1 + 4$	$d_1 + 24$	12.0 ± 1.8	V-190A	TWVA01900
195 - 210	180	8	9.0	14.5	$d_1 + 4$	$d_1 + 24$	12.0 ± 1.8	V-199A	TWVA01990
190 - 210	180	15	14.3	25.0	$d_1 + 10$	$d_1 + 45$	20.0 ± 4.0	V-200A	TWVA02000
210 - 235	198	15	14.3	25.0	$d_1 + 10$	$d_1 + 45$	20.0 ± 4.0	V-220A	TWVA02200
235 - 265	225	15	14.3	25.0	$d_1 + 10$	$d_1 + 45$	20.0 ± 4.0	V-250A	TWVA02500
265 - 290	247	15	14.3	25.0	$d_1 + 10$	$d_1 + 45$	20.0 ± 4.0	V-275A	TWVA02750
290 - 310	270	15	14.3	25.0	$d_1 + 10$	$d_1 + 45$	20.0 ± 4.0	V-300A	TWVA03000
310 - 335	292	15	14.3	25.0	$d_1 + 10$	$d_1 + 45$	20.0 ± 4.0	V-325A	TWVA03250
335 - 365	315	15	14.3	25.0	$d_1 + 10$	$d_1 + 45$	20.0 ± 4.0	V-350A	TWVA03500
365 - 390	337	15	14.3	25.0	$d_1 + 10$	$d_1 + 45$	20.0 ± 4.0	V-375A	TWVA03750
390 - 430	360	15	14.3	25.0	$d_1 + 10$	$d_1 + 45$	20.0 ± 4.0	V-400A	TWVA04000
430 - 480	405	15	14.3	25.0	$d_1 + 10$	$d_1 + 45$	20.0 ± 4.0	V-450A	TWVA04500
480 - 530	450	15	14.3	25.0	$d_1 + 10$	$d_1 + 45$	20.0 ± 4.0	V-500A	TWVA05000
530 - 580	495	15	14.3	25.0	$d_1 + 10$	$d_1 + 45$	20.0 ± 4.0	V-550A	TWVA05500
580 - 630	540	15	14.3	25.0	$d_1 + 10$	$d_1 + 45$	20.0 ± 4.0	V-600A	TWVA06000
630 - 665	600	15	14.3	25.0	$d_1 + 10$	$d_1 + 45$	20.0 ± 4.0	V-650A	TWVA06500
665 - 705	630	15	14.3	25.0	$d_1 + 10$	$d_1 + 45$	20.0 ± 4.0	V-700A	TWVA07000
705 - 745	670	15	14.3	25.0	$d_1 + 10$	$d_1 + 45$	20.0 ± 4.0	V-725A	TWVA07250
745 - 785	705	15	14.3	25.0	$d_1 + 10$	$d_1 + 45$	20.0 ± 4.0	V-750A	TWVA07500
785 - 830	745	15	14.3	25.0	$d_1 + 10$	$d_1 + 45$	20.0 ± 4.0	V-800A	TWVA08000
830 - 875	785	15	14.3	25.0	$d_1 + 10$	$d_1 + 45$	20.0 ± 4.0	V-850A	TWVA08500
875 - 920	825	15	14.3	25.0	$d_1 + 10$	$d_1 + 45$	20.0 ± 4.0	V-900A	TWVA09000
920 - 965	865	15	14.3	25.0	$d_1 + 10$	$d_1 + 45$	20.0 ± 4.0	V-950A	TWVA09500
965 - 1015	910	15	14.3	25.0	$d_1 + 10$	$d_1 + 45$	20.0 ± 4.0	V-1000A	TWVAX1000
1015 - 1065	955	15	14.3	25.0	$d_1 + 10$	$d_1 + 45$	20.0 ± 4.0	V-1050A	TWVAX1050
1065 - 1115	1000	15	14.3	25.0	$d_1 + 10$	$d_1 + 45$	20.0 ± 4.0	V-1100A	TWVAW1100
1115 - 1165	1045	15	14.3	25.0	$d_1 + 10$	$d_1 + 45$	20.0 ± 4.0	V-1150A	TWVAW1150
1165 - 1215	1090	15	14.3	25.0	$d_1 + 10$	$d_1 + 45$	20.0 ± 4.0	V-1200A	TWVAW1200
1215 - 1270	1135	15	14.3	25.0	$d_1 + 10$	$d_1 + 45$	20.0 ± 4.0	V-1250A	TWVAW1250
1270 - 1320	1180	15	14.3	25.0	$d_1 + 10$	$d_1 + 45$	20.0 ± 4.0	V-1300A	TWVAW1300
1320 - 1370	1225	15	14.3	25.0	$d_1 + 10$	$d_1 + 45$	20.0 ± 4.0	V-1350A	TWVAW1350
1370 - 1420	1270	15	14.3	25.0	$d_1 + 10$	$d_1 + 45$	20.0 ± 4.0	V-1400A	TWVAW1400

V-Ring



For shaft diameter d_1	Inside dia. d	Height of cross-section c	Dimension A	Free width B	Maximum d_2	Minimum d_3	Fitted width B_1	V-Ring FORSHEDA Ref.	TSS Part No.
1420 - 1470	1315	15	14.3	25.0	$d1 + 10$	$d1 + 45$	20.0 ± 4.0	V-1450A	TWVAW1450
1470 - 1520	1360	15	14.3	25.0	$d1 + 10$	$d1 + 45$	20.0 ± 4.0	V-1500A	TWVAW1500
1520 - 1570	1405	15	14.3	25.0	$d1 + 10$	$d1 + 45$	20.0 ± 4.0	V-1550A	TWVAW1550
1570 - 1620	1450	15	14.3	25.0	$d1 + 10$	$d1 + 45$	20.0 ± 4.0	V-1600A	TWVAW1600
1620 - 1670	1495	15	14.3	25.0	$d1 + 10$	$d1 + 45$	20.0 ± 4.0	V-1650A	TWVAW1650
1670 - 1720	1540	15	14.3	25.0	$d1 + 10$	$d1 + 45$	20.0 ± 4.0	V-1700A	TWVAW1700
1720 - 1770	1585	15	14.3	25.0	$d1 + 10$	$d1 + 45$	20.0 ± 4.0	V-1750A	TWVAW1750
1770 - 1820	1630	15	14.3	25.0	$d1 + 10$	$d1 + 45$	20.0 ± 4.0	V-1800A	TWVAW1800
1820 - 1870	1675	15	14.3	25.0	$d1 + 10$	$d1 + 45$	20.0 ± 4.0	V-1850A	TWVAW1850
1870 - 1920	1720	15	14.3	25.0	$d1 + 10$	$d1 + 45$	20.0 ± 4.0	V-1900A	TWVAW1900
1920 - 1970	1765	15	14.3	25.0	$d1 + 10$	$d1 + 45$	20.0 ± 4.0	V-1950A	TWVAW1950
1970 - 2020	1810	15	14.3	25.0	$d1 + 10$	$d1 + 45$	20.0 ± 4.0	V-2000A	TWVAW2000



V-Ring

Dimension table - V-Ring type S

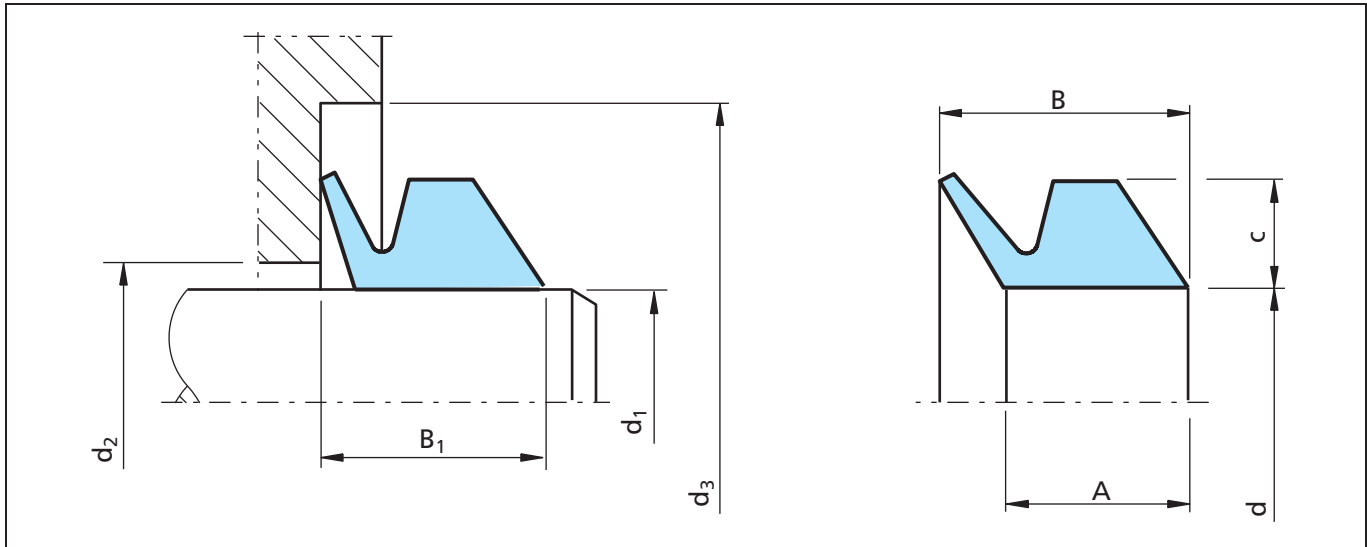

Figure 68 Installation drawing

When the dimension d_1 is on the boundary between two sizes of V-Ring, select the larger V-Ring. All dimensions in mm.

Ordering example

V-Ring, Type S
for shaft diameter = 30.0 mm
Material: N6T50 (Nitrile Elastomer)

TSS Article No.	TWVS00300	-	N6T50
TSS Part No.			
Quality index (standard)			
Material no. (standard)			
Corresponding to FORSHEDA ref. V-30S NBR510			

Table XLVI Profile dimensions - assembly dimensions

For shaft diameter d_1	Inside dia. d	Height of cross-section c	Dimension A	Free width B	Maximum d_2	Minimum d_3	Fitted width B_1	V-Ring FORSHEDA Ref.	TSS Part No.
4.5 - 5.5	4	2	3.9	5.2	$d_1 + 1$	$d_1 + 6$	4.5 ± 0.4	V-5S	TWVS00050
5.5 - 6.5	5	2	3.9	5.2	$d_1 + 1$	$d_1 + 6$	4.5 ± 0.4	V-6S	TWVS00060
6.5 - 8.0	6	2	3.9	5.2	$d_1 + 1$	$d_1 + 6$	4.5 ± 0.4	V-7S	TWVS00070
8.0 - 9.5	7	2	3.9	5.2	$d_1 + 1$	$d_1 + 6$	4.5 ± 0.4	V-8S	TWVS00080
9.5 - 11.5	9	3	5.6	7.7	$d_1 + 1$	$d_1 + 9$	6.7 ± 0.6	V-10S	TWVS00100
11.5 - 13.5	10.5	3	5.6	7.7	$d_1 + 1$	$d_1 + 9$	6.7 ± 0.6	V-12S	TWVS00120
13.5 - 15.5	12.5	3	5.6	7.7	$d_1 + 1$	$d_1 + 9$	6.7 ± 0.6	V-14S	TWVS00140

V-Ring



For shaft diameter d_1	Inside dia. d	Height of cross-section c	Dimension A	Free width B	Maximum d_2	Minimum d_3	Fitted width B_1	V-Ring FORSHEDA Ref.	TSS Part No.
15.5 - 17.5	14	3	5.6	7.7	$d_1 + 1$	$d_1 + 9$	6.7 ± 0.6	V-16S	TWVS00160
17.5 - 19	16	3	5.6	7.7	$d_1 + 1$	$d_1 + 9$	6.7 ± 0.6	V-18S	TWVS00180
19 - 21	18	4	7.9	10.5	$d_1 + 2$	$d_1 + 12$	9.0 ± 0.8	V-20S	TWVS00200
21 - 24	20	4	7.9	10.5	$d_1 + 2$	$d_1 + 12$	9.0 ± 0.8	V-22S	TWVS00220
24 - 27	22	4	7.9	10.5	$d_1 + 2$	$d_1 + 12$	9.0 ± 0.8	V-25S	TWVS00250
27 - 29	25	4	7.9	10.5	$d_1 + 2$	$d_1 + 12$	9.0 ± 0.8	V-28S	TWVS00280
29 - 31	27	4	7.9	10.5	$d_1 + 2$	$d_1 + 12$	9.0 ± 0.8	V-30S	TWVS00300
31 - 33	29	4	7.9	10.5	$d_1 + 2$	$d_1 + 12$	9.0 ± 0.8	V-32S	TWVS00320
33 - 36	31	4	7.9	10.5	$d_1 + 2$	$d_1 + 12$	9.0 ± 0.8	V-35S	TWVS00350
36 - 38	34	4	7.9	10.5	$d_1 + 2$	$d_1 + 12$	9.0 ± 0.8	V-38S	TWVS00380
38 - 43	36	5	9.5	13.0	$d_1 + 2$	$d_1 + 15$	11.0 ± 1.0	V-40S	TWVS00400
43 - 48	40	5	9.5	13.0	$d_1 + 2$	$d_1 + 15$	11.0 ± 1.0	V-45S	TWVS00450
48 - 53	45	5	9.5	13.0	$d_1 + 2$	$d_1 + 15$	11.0 ± 1.0	V-50S	TWVS00500
53 - 58	49	5	9.5	13.0	$d_1 + 2$	$d_1 + 15$	11.0 ± 1.0	V-55S	TWVS00550
58 - 63	54	5	9.5	13.0	$d_1 + 2$	$d_1 + 15$	11.0 ± 1.0	V-60S	TWVS00600
63 - 68	58	5	9.5	13.0	$d_1 + 2$	$d_1 + 15$	11.0 ± 1.0	V-65S	TWVS00650
68 - 73	63	6	11.3	15.5	$d_1 + 3$	$d_1 + 18$	13.5 ± 1.2	V-70S	TWVS00700
73 - 78	67	6	11.3	15.5	$d_1 + 3$	$d_1 + 18$	13.5 ± 1.2	V-75S	TWVS00750
78 - 83	72	6	11.3	15.5	$d_1 + 3$	$d_1 + 18$	13.5 ± 1.2	V-80S	TWVS00800
83 - 88	76	6	11.3	15.5	$d_1 + 3$	$d_1 + 18$	13.5 ± 1.2	V-85S	TWVS00850
88 - 93	81	6	11.3	15.5	$d_1 + 3$	$d_1 + 18$	13.5 ± 1.2	V-90S	TWVS00900
93 - 98	85	6	11.3	15.5	$d_1 + 3$	$d_1 + 18$	13.5 ± 1.2	V-95S	TWVS00950
98 - 105	90	6	11.3	15.5	$d_1 + 3$	$d_1 + 18$	13.5 ± 1.2	V-100S	TWVS01000
105 - 115	99	7	13.1	18.0	$d_1 + 4$	$d_1 + 21$	15.5 ± 1.5	V-110S	TWVS01100
115 - 125	108	7	13.1	18.0	$d_1 + 4$	$d_1 + 21$	15.5 ± 1.5	V-120S	TWVS01200
125 - 135	117	7	13.1	18.0	$d_1 + 4$	$d_1 + 21$	15.5 ± 1.5	V-130S	TWVS01300
135 - 145	126	7	13.1	18.0	$d_1 + 4$	$d_1 + 21$	15.5 ± 1.5	V-140S	TWVS01400
145 - 155	135	7	13.1	18.0	$d_1 + 4$	$d_1 + 21$	15.5 ± 1.5	V-150S	TWVS01500
155 - 165	144	8	15.0	20.5	$d_1 + 4$	$d_1 + 24$	18.0 ± 1.8	V-160S	TWVS01600
165 - 175	153	8	15.0	20.5	$d_1 + 4$	$d_1 + 24$	18.0 ± 1.8	V-170S	TWVS01700
175 - 185	162	8	15.0	20.5	$d_1 + 4$	$d_1 + 24$	18.0 ± 1.8	V-180S	TWVS01800
185 - 195	171	8	15.0	20.5	$d_1 + 4$	$d_1 + 24$	18.0 ± 1.8	V-190S	TWVS01900
195 - 210	180	8	15.0	20.5	$d_1 + 4$	$d_1 + 24$	18.0 ± 1.8	V-199S	TWVS01990



V-Ring

Dimension table - V-Ring type L / LX

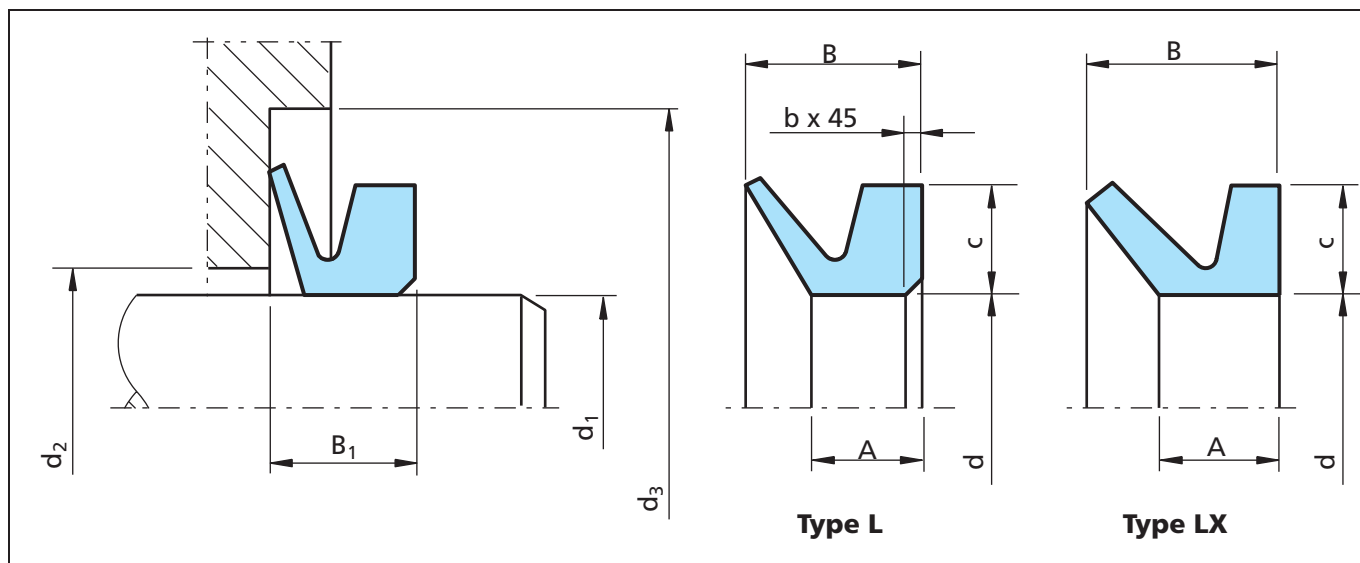

Figure 69 Installation drawing

When the dimension d_1 is on the boundary between two sizes of V-Ring, select the larger V-Ring. All dimensions in mm.

Table XLVII Installation dimensions

Type	c	A	B	b	B_1	$d_3 \text{ min}$	$d_2 \text{ max}$
L	6.5	6	10.5	1	8 ± 1.5	$d_1 + 20$	$d_1 + 5$
LX	5	5.4	8.5	0	6.8 ± 1.1	$d_1 + 15$	$d_1 + 4$

Ordering example

V-Ring, Type L
for shaft diameter = 205 mm
Material: N6T50 (Nitrile Elastomer)

TSS Article No.	TWVL02000	-	N6T50
TSS Part No.			
Quality index (standard)			
Material no. (standard)			
Corresponding to FORSHEDA ref. V-200L NBR510			

Ordering example

V-Ring, Type LX
for shaft diameter = 205 mm
Material: N6T50 (Nitrile Elastomer)

TSS Article No.	TWLXV2000	-	N6T50
TSS Part No.			
Quality index (standard)			
Material no. (standard)			
Corresponding to FORSHEDA ref. V-200LX NBR510			



Table XLIX Profile dimensions - assembly dimensions

For shaft diameter d_1	Inside diameter d	V-Ring FORSHEDA Ref.	TSS Part No. Type L	TSS Part No. Type LX
105 - 115	99	V-110L	TWVL01100	
115 - 125	108	V-120L	TWVL01200	
125 - 135	117	V-130L	TWVL01300	
135 - 145	126	V-140L/LX	TWVL01400	TWLX01400
145 - 155	135	V-150L/LX	TWVL01500	TWLX01500
155 - 165	144	V-160L/LX	TWVL01600	TWLXV1600
165 - 175	153	V-170L/LX	TWVL01700	TWLXV1700
175 - 185	162	V-180L/LX	TWVL01800	TWLXV1800
185 - 195	171	V-190L/LX	TWVL01900	TWLXV1900
195 - 210	182	V-200L/LX	TWVL02000	TWLXV2000
210 - 233	198	V-220L/LX	TWVL02200	TWLXV2200
233 - 260	225	V-250L/LX	TWVL02500	TWLXV2500
260 - 285	247	V-275L/LX	TWVL02750	TWLXV2750
285 - 310	270	V-300L/LX	TWVL03000	TWLXV3000
310 - 335	292	V-325L/LX	TWVL03250	TWLXV3250
335 - 365	315	V-350L/LX	TWVL03500	TWLXV3500
365 - 385	337	V-375L/LX	TWVL03750	TWLXV3750
385 - 410	360	V-400L/LX	TWVL04000	TWLXV4000
410 - 440	382	V-425L/LX	TWVLV4250	TWLXV4250
440 - 475	405	V-450L/LX	TWVL04500	TWLXV4500
475 - 510	450	V-500L/LX	TWVLV5000	TWLXV5000
510 - 540	472	V-525L/LX	TWVLV5250	TWLXV5250
540 - 575	495	V-550L/LX	TWVLV5500	TWLXV5500
575 - 625	540	V-600L/LX	TWVLV6000	TWLXV6000
625 - 675	600	V-650L/LX	TWVLV6500	TWLXV6500
675 - 710	630	V-700L/LX	TWVLV7000	TWLXV7000
710 - 740	670	V-725L/LX	TWVLV7250	TWLXV7250
740 - 775	705	V-750L/LX	TWVLV7500	TWLXV7500
775 - 825	745	V-800L/LX	TWVL08000	TWLXV8000
825 - 875	785	V-850L/LX	TWVLV8500	TWLXV8500
875 - 925	825	V-900L/LX	TWVLV9000	TWLXV9000
925 - 975	865	V-950L/LX	TWVLV9500	TWLXV9500
975 - 1025	910	V-1000L/LX	TWVLW1000	TWLXW1000
1025 - 1075	955	V-1050L/LX	TWVLW1050	TWLXW1050
1075 - 1125	1000	V-1100L/LX	TWVLW1100	TWLXW1100
1125 - 1175	1045	V-1150L/LX	TWVLW1150	TWLXW1150



V-Ring

For shaft diameter d_1	Inside diameter d	V-Ring FORSHEDA Ref.	TSS Part No. Type L	TSS Part No. Type LX
1175 - 1225	1090	V-1200L/LX	TWVLW1200	TWLXW1200
1225 - 1275	1135	V-1250L/LX	TWVLW1250	TWLXW1250
1275 - 1325	1180	V-1300L/LX	TWVLW1300	TWLXW1300
1325 - 1375	1225	V-1350L/LX	TWVLW1350	TWLXW1350
1375 - 1425	1270	V-1400L/LX	TWVLW1400	TWLXW1400
1425 - 1475	1315	V-1450L/LX	TWVLW1450	TWLXW1450
1475 - 1525	1360	V-1500L/LX	TWVLW1500	TWLXW1500
1525 - 1575	1405	V-1550L/LX	TWVLW1550	TWLXW1550
1575 - 1625	1450	V-1600L/LX	TWVLW1600	TWLXW1600
1625 - 1675	1495	V-1650L/LX	TWVLW1650	TWLXW1650
1675 - 1725	1540	V-1700L/LX	TWVLW1700	TWLXW1700
1725 - 1775	1585	V-1750L/LX	TWVLW1750	TWLXW1750
1775 - 1825	1630	V-1800L/LX	TWVLW1800	TWLXW1800
1825 - 1875	1675	V-1850L/LX	TWVLW1850	TWLXW1850
1875 - 1925	1720	V-1900L/LX	TWVLW1900	TWLXW1900
1925 - 1975	1765	V-1950L/LX	TWVLW1950	TWLXW1950
1975 - 2025	1810	V-2000L/LX	TWVLW2000	TWLXW2000

V-Ring L or LX larger than 2000 made to special order



■ Dimension table - V-Ring type RM / RME

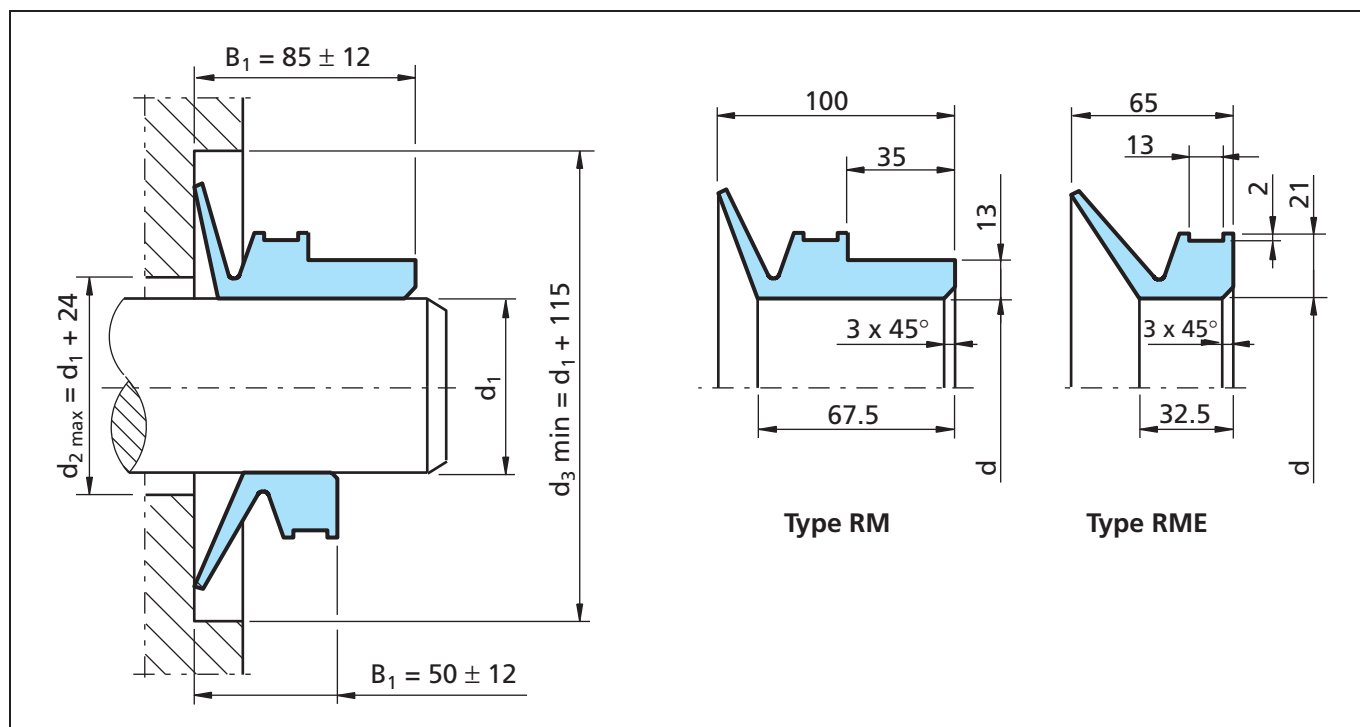

Figure 70 Installation drawing

When the dimension d_1 is on the boundary between two sizes of V-Ring, select the larger V-Ring. All dimensions in mm.

Ordering example

V-Ring, Type RME, for clamping band, butt-vulcanized for shaft diameter = 500.0 mm
Material: N6T50 (Nitrile Elastomer)

TSS Article No.	TWVBV5000	-	N6T50
TSS Part No.			
Quality index (standard)			
Material no. (standard)			
Corresponding to FORSHEDA ref. V-500RME NBR510			

Ordering example

V-Ring, Type RM, for clamping band, butt-vulcanized for shaft diameter = 500.0 mm
Material: N6T50 (Nitrile Elastomer)

TSS Article No.	TWRMV5000	-	N6T50
TSS Part No.			
Quality index (standard)			
Material no. (standard)			
Corresponding to FORSHEDA ref. V-500RM NBR510			



V-Ring

Table XLVIII Profile dimensions - assembly dimensions

For shaft diameter d_1	Inside diameter d	V-Ring FORSHEDA Ref.	TSS Part No. type RM	TSS Part No. type RME
300 - 305	294	V-300RM/RME	TWRMV3000	TWVBV3000
305 - 310	299	V-305RM/RME	TWRMV3050	TWVBV3050
310 - 315	304	V-310RM/RME	TWRMV3100	TWVBV3100
315 - 320	309	V-315RM/RME	TWRMV3150	TWVBV3150
320 - 325	314	V-320RM/RME	TWRMV3200	TWVBV3200
325 - 330	319	V-325RM/RME	TWRMV3250	TWVBV3250
330 - 335	323	V-330RM/RME	TWRMV3300	TWVBV3300
335 - 340	328	V-335RM/RME	TWRMV3350	TWVBV3350
345 - 350	338	V-345RM/RME	TWRMV3450	TWVBV3450
350 - 355	343	V-350RM/RME	TWRMV3500	TWVBV3500
355 - 360	347	V-355RM/RME	TWRMV3550	TWVBV3550
360 - 365	352	V-360RM/RME	TWRMV3600	TWVBV3600
365 - 370	357	V-365RM/RME	TWRMV3650	TWVBV3650
370 - 375	362	V-370RM/RME	TWRMV3700	TWVBV3700
375 - 380	367	V-375RM/RME	TWRMV3750	TWVBV3750
380 - 385	371	V-380RM/RME	TWRMV3800	TWVBV3800
385 - 390	376	V-385RM/RME	TWRMV3850	TWVBV3850
390 - 395	381	V-390RM/RME	TWRMV3900	TWVBV3900
395 - 400	386	V-395RM/RME	TWRMV3950	TWVBV3950
400 - 405	391	V-400RM/RME	TWRMV4000	TWVBV4000
405 - 410	396	V-405RM/RME	TWRMV4050	TWVBV4050
410 - 415	401	V-410RM/RME	TWRMV4100	TWVBV4100
415 - 420	405	V-415RM/RME	TWRMV4150	TWVBV4150
420 - 425	410	V-420RM/RME	TWRMV4200	TWVBV4200
425 - 430	415	V-425RM/RME	TWRMV4250	TWVBV4250
430 - 435	420	V-430RM/RME	TWRMV4300	TWVBV4300
435 - 440	425	V-435RM/RME	TWRMV4350	TWVBV4350
440 - 445	429	V-440RM/RME	TWRMV4400	TWVBV4400
445 - 450	434	V-445RM/RME	TWRMV4450	TWVBV4450
450 - 455	439	V-450RM/RME	TWRMV4500	TWVBV4500
455 - 460	444	V-455RM/RME	TWRMV4550	TWVBV4550
460 - 465	448	V-460RM/RME	TWRMV4600	TWVBV4600
465 - 470	453	V-465RM/RME	TWRMV4650	TWVBV4650
470 - 475	458	V-470RM/RME	TWRMV4700	TWVBV4700
475 - 480	463	V-475RM/RME	TWRMV4750	TWVBV4750





For shaft diameter d_1	Inside diameter d	V-Ring FORSHEDA Ref.	TSS Part No. type RM	TSS Part No. type RME
480 - 485	468	V-480RM/RME	TWRMV4800	TWVBV4800
485 - 490	473	V-485RM/RME	TWRMV4850	TWVBV4850
490 - 495	478	V-490RM/RME	TWRMV4900	TWVBV4900
495 - 500	483	V-495RM/RME	TWRMV4950	TWVBV4950
500 - 505	488	V-500RM/RME	TWRMV5000	TWVBV5000
505 - 510	493	V-505RM/RME	TWRMV5050	TWVBV5050
510 - 515	497	V-510RM/RME	TWRMV5100	TWVBV5100
515 - 520	502	V-515RM/RME	TWRMV5150	TWVBV5150
520 - 525	507	V-520RM/RME	TWRMV5200	TWVBV5200
525 - 530	512	V-525RM/RME	TWRMV5250	TWVBV5250
530 - 535	517	V-530RM/RME	TWRMV5300	TWVBV5300
535 - 540	521	V-535RM/RME	TWRMV5350	TWVBV5350
540 - 545	526	V-540RM/RME	TWRMV5400	TWVBV5400
545 - 550	531	V-545RM/RME	TWRMV5450	TWVBV5450
550 - 555	536	V-550RM/RME	TWRMV5500	TWVBV5500
555 - 560	541	V-555RM/RME	TWRMV5550	TWVBV5550
560 - 565	546	V-560RM/RME	TWRM05600	TWVB05600
565 - 570	550	V-565RM/RME	TWRMV5650	TWVBV5650
570 - 575	555	V-570RM/RME	TWRMV5700	TWVBV5700
575 - 580	560	V-575RM/RME	TWRMV5750	TWVBV5750
580 - 585	565	V-580RM/RME	TWRMV5800	TWVBV5800
585 - 590	570	V-585RM/RME	TWRMV5850	TWVBV5850
590 - 600	575	V-590RM/RME	TWRMV5900	TWVBV5900
600 - 610	582	V-600RM/RME	TWRMV6000	TWVBV6000
610 - 620	592	V-610RM/RME	TWRMV6100	TWVBV6100
620 - 630	602	V-620RM/RME	TWRMV6200	TWVBV6200
630 - 640	612	V-630RM/RME	TWRMV6300	TWVBV6300
640 - 650	621	V-640RM/RME	TWRMV6400	TWVBV6400
650 - 660	631	V-650RM/RME	TWRMV6500	TWVBV6500
660 - 670	640	V-660RM/RME	TWRMV6600	TWVBV6600
670 - 680	650	V-670RM/RME	TWRMV6700	TWVBV6700
680 - 690	660	V-680RM/RME	TWRMV6800	TWVBV6800
690 - 700	670	V-690RM/RME	TWRMV6900	TWVBV6900
700 - 710	680	V-700RM/RME	TWRMV7000	TWVBV7000
710 - 720	689	V-710RM/RME	TWRMV7100	TWVBV7100



V-Ring

For shaft diameter d_1	Inside diameter d	V-Ring FORSHEDA Ref.	TSS Part No. type RM	TSS Part No. type RME
720 - 730	699	V-720RM/RME	TWRMV7200	TWVBV7200
730 - 740	709	V-730RM/RME	TWRMV7300	TWVBV7300
740 - 750	718	V-740RM/RME	TWRMV7400	TWVBV7400
750 - 758	728	V-750RM/RME	TWRMV7500	TWVBV7500
758 - 766	735	V-760RM/RME	TWRMV7600	TWVBV7600
766 - 774	743	V-770RM/RME	TWRMV7700	TWVBV7700
774 - 783	751	V-780RM/RME	TWRMV7800	TWVBV7800
783 - 792	759	V-790RM/RME	TWRMV7900	TWVBV7900
792 - 801	768	V-800RM/RME	TWRMV8000	TWVBV8000
801 - 810	777	V-810RM/RME	TWRMV8100	TWVBV8100
810 - 821	786	V-820RM/RME	TWRMV8200	TWVBV8200
821 - 831	796	V-830RM/RME	TWRMV8300	TWVBV8300
831 - 841	805	V-840RM/RME	TWRMV8400	TWVBV8400
841 - 851	814	V-850RM/RME	TWRMV8500	TWVBV8500
851 - 861	824	V-860RM/RME	TWRMV8600	TWVBV8600
861 - 871	833	V-870RM/RME	TWRMV8700	TWVBV8700
871 - 882	843	V-880RM/RME	TWRMV8800	TWVBV8800
882 - 892	853	V-890RM/RME	TWRMV8900	TWVBV8900
892 - 912	871	V-900RM/RME	TWRMV9000	TWVBV9000
912 - 922	880	V-920RM/RME	TWRMV9200	TWVBV9200
922 - 933	890	V-930RM/RME	TWRMV9300	TWVBV9300
933 - 944	900	V-940RM/RME	TWRMV9400	TWVBV9400
944 - 955	911	V-950RM/RME	TWRMV9500	TWVBV9500
955 - 966	921	V-960RM/RME	TWRMV9600	TWVBV9600
966 - 977	932	V-970RM/RME	TWRMV9700	TWVBV9700
977 - 988	942	V-980RM/RME	TWRMV9800	TWVBV9800
988 - 999	953	V-990RM/RME	TWRMV9900	TWVBV9900
999 - 1010	963	V-1000RM/RME	TWRMW1000	TWVBW1000
1010 - 1025	973	V-1020RM/RME	TWRMW1020	TWVBW1020
1025 - 1045	990	V-1040RM/RME	TWRMW1040	TWVBW1040
1045 - 1065	1008	V-1060RM/RME	TWRMW1060	TWVBW1060
1065 - 1085	1027	V-1080RM/RME	TWRMW1080	TWVBW1080
1085 - 1105	1045	V-1100RM/RME	TWRM01100	TWVB01100
1105 - 1125	1065	V-1120RM/RME	TWRMW1120	TWVBW1120
1125 - 1145	1084	V-1140RM/RME	TWRMW1140	TWVBW1140



For shaft diameter d_1	Inside diameter d	V-Ring FORSHEDA Ref.	TSS Part No. type RM	TSS Part No. type RME
1145 - 1165	1103	V-1160RM/RME	TWRMW1160	TWVBW1160
1165 - 1185	1121	V-1180RM/RME	TWRMW1180	TWVBW1180
1185 - 1205	1139	V-1200RM/RME	TWRMW1200	TWVBW1200
1205 - 1225	1157	V-1220RM/RME	TWRMW1220	TWVBW1220
1225 - 1245	1176	V-1240RM/RME	TWRMW1240	TWVBW1240
1245 - 1270	1195	V-1260RM/RME	TWRMW1260	TWVBW1260
1270 - 1295	1218	V-1280RM/RME	TWRMW1280	TWVBW1280
1295 - 1315	1240	V-1300RM/RME	TWRMW1300	TWVBW1300
1315 - 1340	1259	V-1325RM/RME	TWRMW1325	TWVBW1325
1340 - 1365	1281	V-1350RM/RME	TWRMW1350	TWVBW1350
1365 - 1390	1305	V-1375RM/RME	TWRMW1375	TWVBW1375
1390 - 1415	1328	V-1400RM/RME	TWRMW1400	TWVBW1400
1415 - 1440	1350	V-1425RM/RME	TWRMW1425	TWVBW1425
1440 - 1465	1374	V-1450RM/RME	TWRMW1450	TWVBW1450
1465 - 1490	1397	V-1475RM/RME	TWRMW1475	TWVBW1475
1490 - 1515	1419	V-1500RM/RME	TWRMW1500	TWVBW1500
1515 - 1540	1443	V-1525RM/RME	TWRMW1525	TWVBW1525
1540 - 1570	1467	V-1550RM/RME	TWRMW1550	TWVBW1550
1570 - 1600	1495	V-1575RM/RME	TWRMW1575	TWVBW1575
1600 - 1640	1524	V-1600RM/RME	TWRMW1600	TWVBW1600
1640 - 1680	1559	V-1650RM/RME	TWRMW1650	TWVBW1650
1680 - 1720	1596	V-1700RM/RME	TWRMW1700	TWVBW1700
1720 - 1765	1632	V-1750RM/RME	TWRMW1750	TWVBW1750
1765 - 1810	1671	V-1800RM/RME	TWRMW1800	TWVBW1800
1810 - 1855	1714	V-1850RM/RME	TWRMW1850	TWVBW1850
1855 - 1905	1753	V-1900RM/RME	TWRMW1900	TWVBW1900
1905 - 1955	1794	V-1950RM/RME	TWRMW1950	TWVBW1950
1955 - 2010	1844	V-2000RM/RME	TWRMW2000	TWVBW2000

V-Ring RM or RME larger than 2000 made to special order.



V-Ring

Dimension table - V-Ring type AX

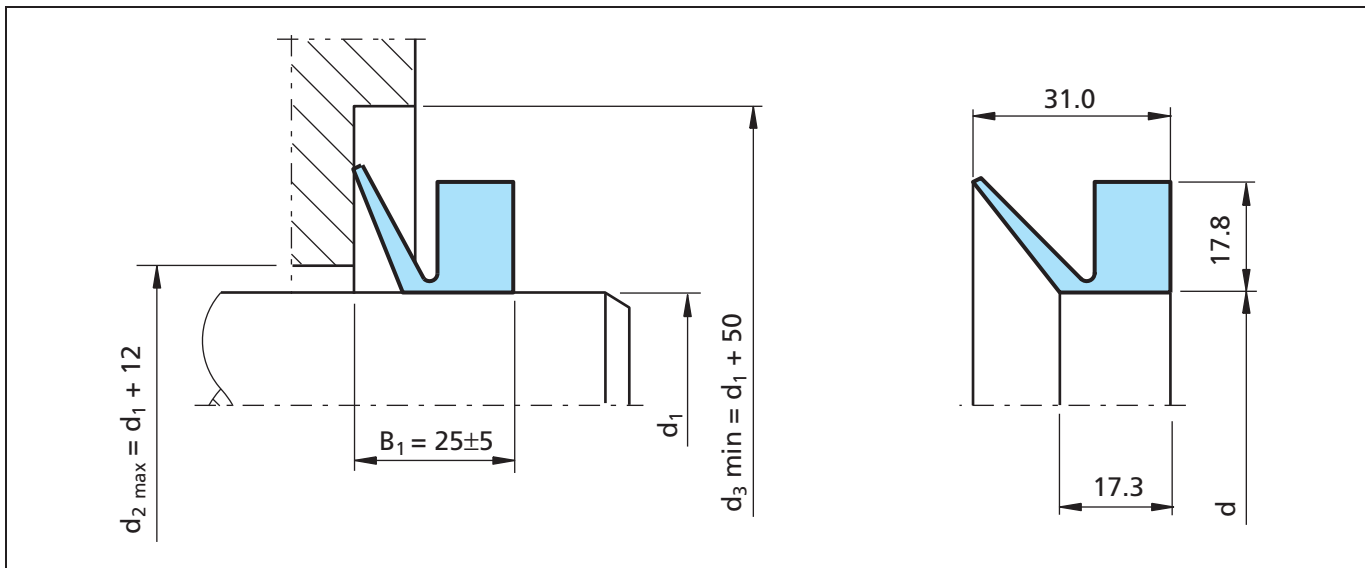

Figure 71 Installation drawing

When the dimension d_1 is on the boundary between two sizes of V-Ring, select the larger V-Ring. All dimensions in mm.

Ordering example

V-Ring, Type AX
for shaft diameter = 1190 mm
Material: N6T50 (Nitrile Elastomer)

TSS Article No.	TWAXW1200	-	N6T50
TSS Part No.			
Quality index (standard)			
Material no. (standard)			
Corresponding to FORSHEDA ref. V-1200AX NBR510			

Table L Profile dimensions - assembly dimensions

For shaft diameter d_1	Inside diameter d	V-Ring FORSHEDA Ref.	TSS Part No.
200 - 205	192	V-200AX	TWAXV2000
205 - 210	196	V-205AX	TWAXV2050
210 - 215	200	V-210AX	TWAXV2100
215 - 219	204	V-215AX	TWAXV2150
219 - 224	207	V-220AX	TWAXV2200
224 - 228	211	V-225AX	TWAXV2250



For shaft diameter d_1	Inside diameter d	V-Ring FORSHEDA Ref.	TSS Part No.
228 - 232	215	V-230AX	TWAXV2300
232 - 236	219	V-235AX	TWAXV2350
236 - 240	223	V-240AX	TWAXV2400
240 - 250	227	V-250AX	TWAXV2500
250 - 260	236	V-260AX	TWAXV2600
260 - 270	245	V-270AX	TWAXV2700
270 - 281	255	V-280AX	TWAXV2800
281 - 292	265	V-290AX	TWAXV2900
292 - 303	275	V-300AX	TWAXV3000
303 - 313	285	V-310AX	TWAXV3100
313 - 325	295	V-320AX	TWAXV3200
325 - 335	305	V-330AX	TWAXV3300
335 - 345	315	V-340AX	TWAXV3400
345 - 355	322	V-350AX	TWAXV3500
355 - 372	328	V-360AX	TWAXV3600
372 - 390	344	V-380AX	TWAXV3800
390 - 415	360	V-400AX	TWAXV4000
415 - 443	385	V-425AX	TWAX04250
443 - 480	410	V-450AX	TWAXV4500
480 - 530	450	V-500AX	TWAXV5000
530 - 580	495	V-550AX	TWAXV5500
580 - 630	540	V-600AX	TWAXV6000
630 - 665	600	V-650AX	TWAX06500
665 - 705	630	V-700AX	TWAXV7000
705 - 745	670	V-725AX	TWAXV7250
745 - 785	705	V-750AX	TWAXV7500
785 - 830	745	V-800AX	TWAXV8000
830 - 875	785	V-850AX	TWAXV8500
875 - 920	825	V-900AX	TWAXV9000
920 - 965	865	V-950AX	TWAXV9500
965 - 1015	910	V-1000AX	TWAXW1000
1015 - 1065	955	V-1050AX	TWAXX1050
1065 - 1115	1000	V-1100AX	TWAXW1100
1115 - 1165	1045	V-1150AX	TWAXW1150
1165 - 1215	1090	V-1200AX	TWAXW1200
1215 - 1270	1135	V-1250AX	TWAXW1250
1270 - 1320	1180	V-1300AX	TWAXW1300
1320 - 1370	1225	V-1350AX	TWAXW1350
1370 - 1420	1270	V-1400AX	TWAXW1400



V-Ring

For shaft diameter d_1	Inside diameter d	V-Ring FORSHEDA Ref.	TSS Part No.
1420 - 1470	1315	V-1450AX	TWAXW1450
1470 - 1520	1360	V-1500AX	TWAXW1500
1520 - 1570	1405	V-1550AX	TWAXW1550
1570 - 1620	1450	V-1600AX	TWAXW1600
1620 - 1670	1495	V-1650AX	TWAXW1650
1670 - 1720	1540	V-1700AX	TWAXW1700
1720 - 1770	1585	V-1750AX	TWAXW1750
1770 - 1820	1630	V-1800AX	TWAXW1800
1820 - 1870	1675	V-1850AX	TWAXW1850
1870 - 1920	1720	V-1900AX	TWAXW1900
1920 - 1970	1765	V-1950AX	TWAXW1950
1970 - 2020	1810	V-2000AX	TWAXW2000

V-Ring AX larger than 2000 made to special order.
Profile and axial fitted width the same as for the standard
V-Ring AX.

Gamma Seal

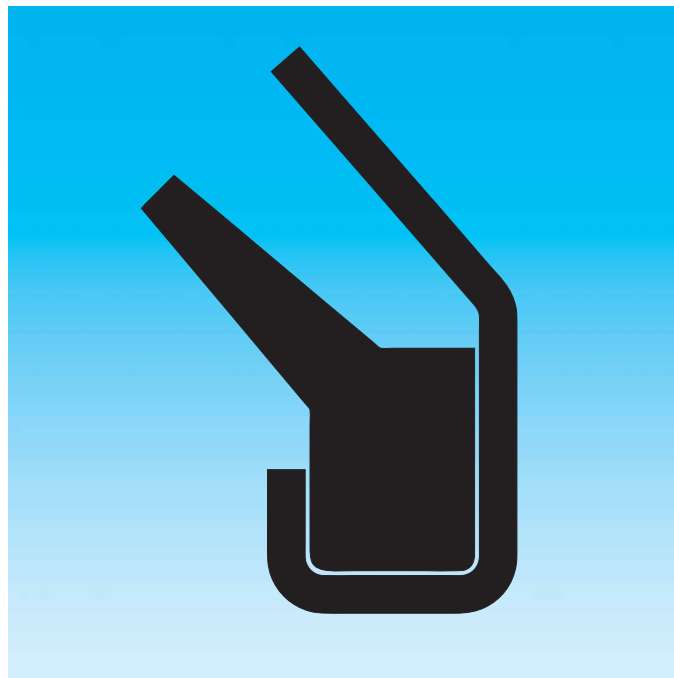





■ GAMMA SEAL

General description

The GAMMA seal is the result of a large-scale development project covering many years of attempts to combine the capability of conventional mechanical seals to operate at high speeds with the simplicity of the Rotary Shaft Lip Seal. Figure 78 shows the different types, which are characterized by simple design. The basic design consists of two parts, sealing element and metal case. The GAMMA seal is designed to be fixed to the shaft at a pre-determined distance from the sealing surface, which is positioned perpendicularly to the shaft, for example the end wall of a bearing housing. During rotation, the sealing lip rubs against the counter face under a contact pressure calculated to achieve a sealing function. The seal also operates as a deflector ring, and its centrifugal action contributes to good sealing function. Due to the effect of centrifugal force, the sealing lip tends to reduce its contact pressure with increasing speed. As a result, the curve for power loss is very favorable (see Figure 73). At a peripheral speed of around 12 m/s, friction losses begin to diminish and cease completely at about 20 m/s, when the sealing lip has completely lifted free of counter faces. The GAMMA seal then functions as a combined deflector ring and clearance seal.

The GAMMA seal is primarily intended for sealing against foreign matter, liquid splatter, grease.

The foremost features of the GAMMA seal are:

- very narrow installation width
- friction diminishes with increasing rotational speed
- centrifugal action contributes to good sealing
- lower demands on surface smoothness, surface hardness and tolerances
- mechanical protection
- easy to fit

General design parameters

The GAMMA seal permits simple installation design and the requirements on the surface against which the sealing lip works are low. A finish-turned, polished surface with a roughness of 3-5 $\mu\text{m Ra}$ is normally adequate. However, the character of the surface is of greater importance than the action surface roughness value. Surface profiles with sharp peaks must be avoided. Injection-molded light-metal alloys can be used in counter faces without further machining. It is necessary to ensure, however, that the part of the mould that produces the counter face is absolutely flawless.

Cold-rolled steel sheet, stainless or zinc plated sheet are excellent materials for counter faces for GAMMA-seal. In comparison to other types of seals, the GAMMA-seal can better absorb a certain amount of shaft misalignment. It is also relatively insensitive to shaft-to-bore eccentricity and shaft run-out.

Directions of shaft design and fitting are provided in the following sections on GAMMA seal types TBP/RB and TBR/9RB.

GAMMA seal type TBP/RB and TBR/9RB

GAMMA seal type TPB/RB and TBR/9RB consists of an elastic sealing element and a metal case (see Figure 72). The case serves as a holder, support and protection for the sealing element and constitutes a very effective deflector. The components are not bonded to each other, the rubber-sealing element is stretched and held in the case by its elasticity.

Type TBP/RB and TBR/9RB provide a very narrow installation width, which has proved to be very advantageous in certain applications and has permitted this seal to be used in assemblies where other seals could not previously be installed due to lack of space. The seal is press fitted on the shaft, and no other means of fixing is required.



GAMMA Seal

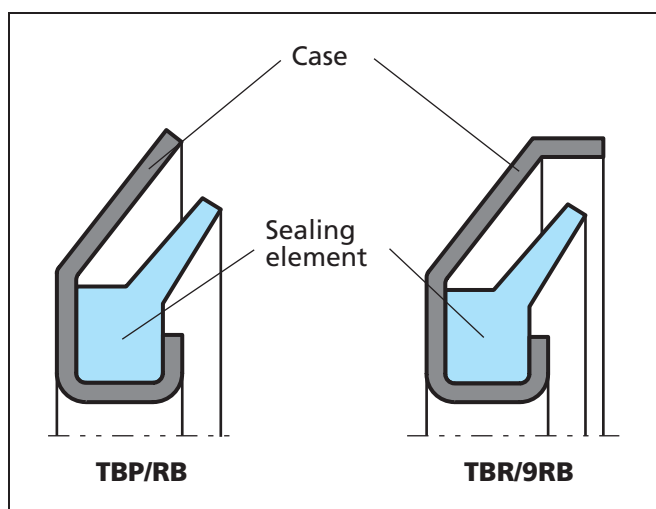

Figure 72 GAMMA seal types

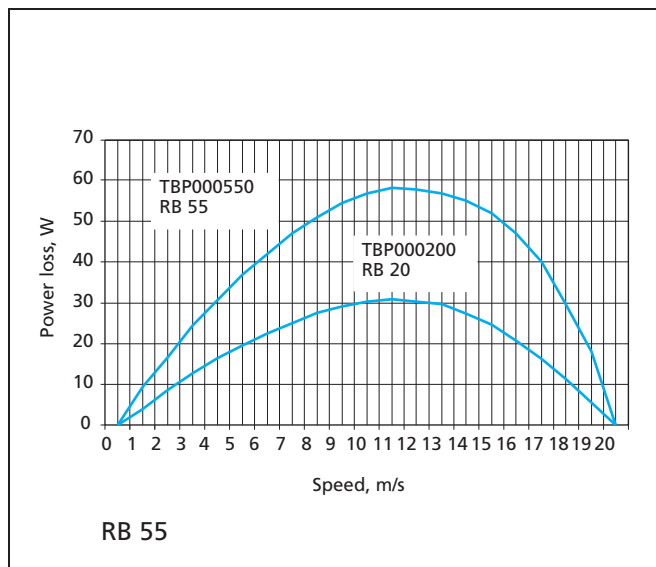

Figure 73 Power loss as a function of peripheral speed (Counterface 1.5-2 μm Ra not lubricated seal)

Manufacturing materials

The sealing element is molded and is normally made of Nitrile rubber with a hardness of 75 ± 5 IRHD. Other compounds can be supplied on request. The case is stamped of cold-rolled steel sheet. In order to ensure a good seal and a tight grip on the shaft, the inside diameter is machined to dimensions which ensure a suitable press fit. The tolerances for the inside diameter of the case are given in Table LI. The case is normally zinc plated. The case can also be made out of other materials, e.g. in stainless steel.

Installation design

GAMMA seal type TBP should normally be installed as shown in Figure 75, i.e. with the seal located in the medium which it is to seal against. As shown in Figure 79 the counter face for type TBR against which the sealing lip works should be designed with a groove for the case extension in order to create the clearance seal. For vertical shafts a design in accordance with Figure 74 is preferred, which effectively will reject impurities and liquid splatter. Shaft tolerance ISO h9 provides a suitable press fit. The shaft tolerances normally used for ball and roller bearings, ISO g6 to n6, can also be used. The seal does not require any other axial fixing other than that which is obtained by the press fit between the case and the shaft.

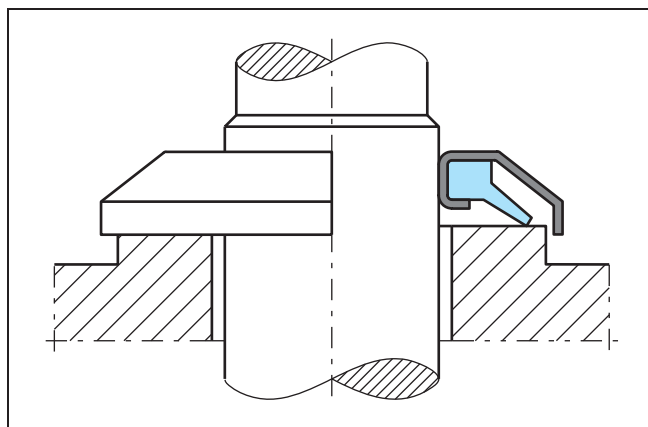

Figure 74 Vertical installation

However, providing a shoulder or a circlip to position the ring may facilitate fitting. The installation dimensions are given in the dimension table.

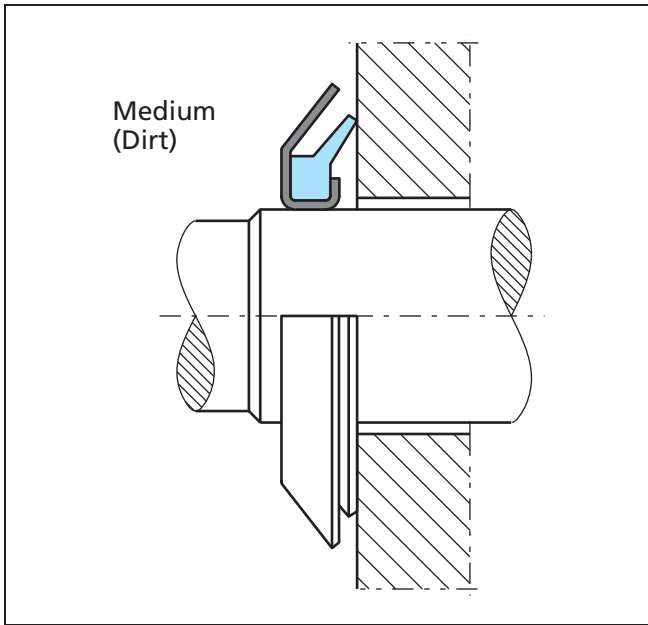

Figure 75 Installation drawing

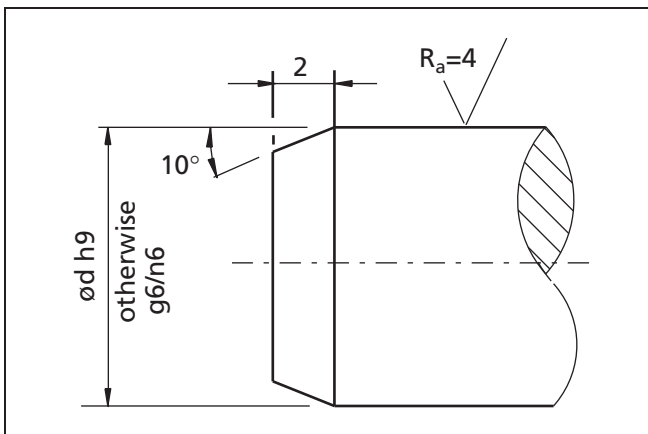

Figure 76 Tolerance of the shaft, surface roughness and chamfer of the shaft

The surface roughness of the shaft should not exceed $4 \mu\text{m}$ Ra. In addition, the shaft should be provided with a chamfer as per Figure 76. Sharp edges or burrs are not permitted. In the case of width b, a variation of $+0.5 \text{ mm}$ is permissible.

Table LI Lead-in chamfers

Inside diameter mm	Chamfer mm	Tolerance mm
0 - 35	2	-0.15 -0.25
36 - 50	2	-0.18 -0.28
51 - 135	2	-0.20 -0.30
136 - 200	2	-0.25 -0.35

Fitting

Prior to being fitted, the sealing member shall be greased, but not between the sealing member and the case. It is important that the seal is fitted with adequate precision. The seal shall be pressed onto the shaft with a uniform and even pressure.

The case must not be tapped directly with the hammer. The seal should therefore be pressed to the right position by means of a suitable assembly tool (see Figures 77, 78 and 79). Since facial fixing beyond the press fit between the seal and the shaft is not provided, the assembly tool should be of a design as shown in Figures 77 and 79 in order to obtain the installation width b as per the dimension tables.



GAMMA Seal

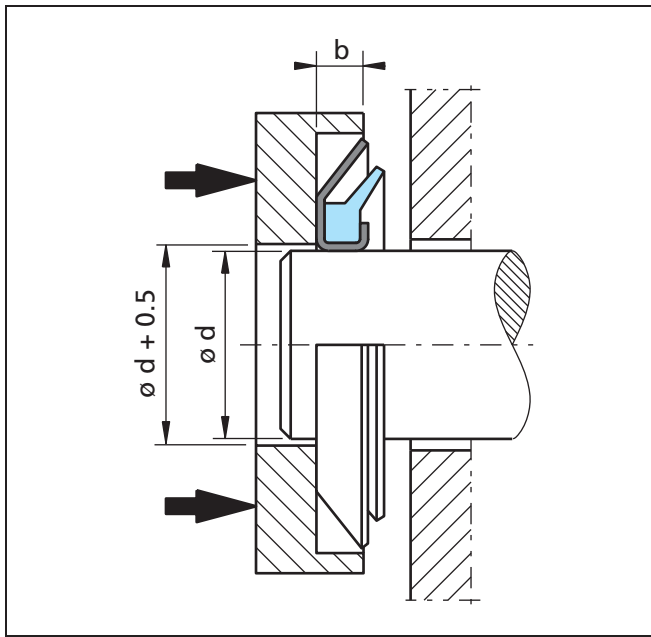

Figure 77 Assembly tool for TBP/RB

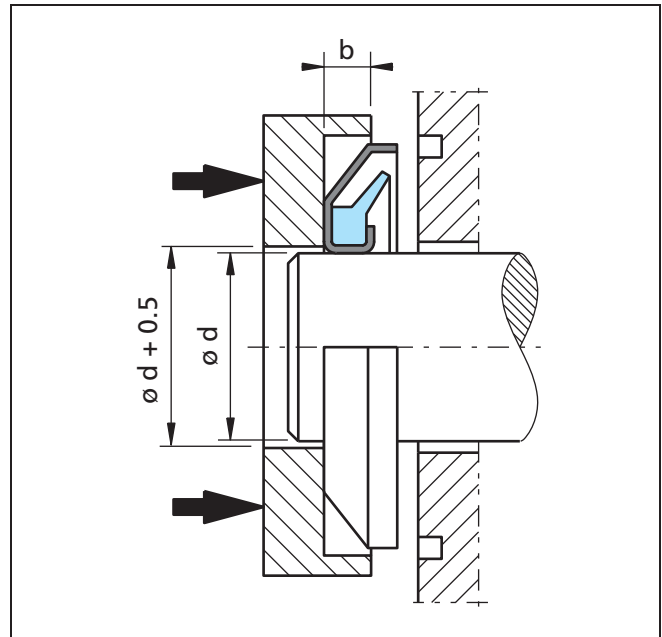

Figure 79 Assembly tool TBR/9RB

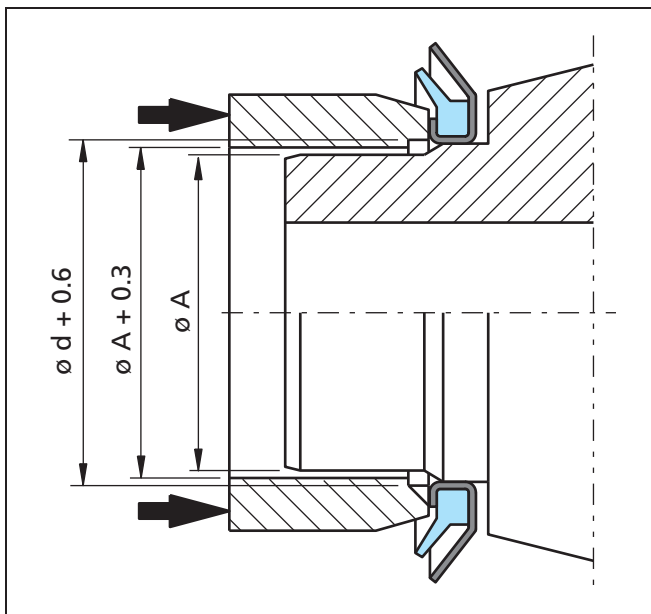

Figure 78 Assembly tool. When positioning the GAMMA seal against a shoulder it is important not to deform the case by pressing with too high load.



■ GAMMA-seal type TBP/RB

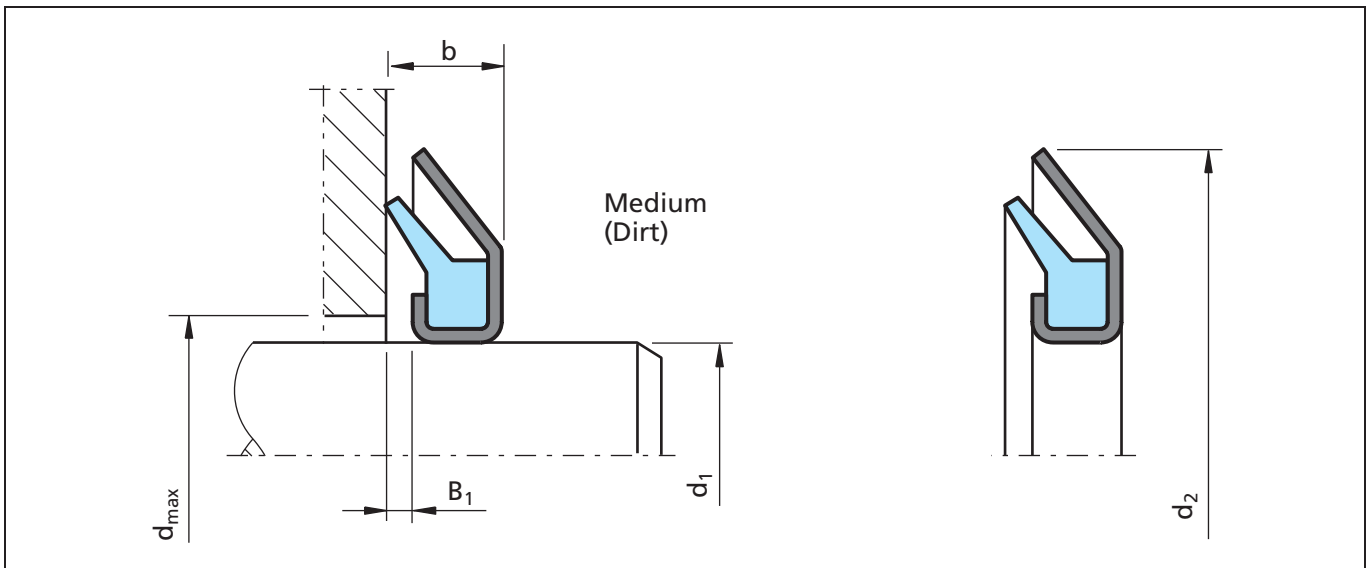

Figure 80 Installation drawing

General description

The design of most commonly used GAMMA seal TBP/RB is based on many years of experience in such applications. The total axial force of the sealing lip is given by elastomer pre-stretching together with lip deformation force which depends on the elasticity of the rubber material, geometry of the sealing lip and assembly positioning against the counter-face. The metal shell is protecting the seal from solids and contributes to exclude other pollution media by centrifusion, allowing a good drainage after immersion in liquids.

Advantages

- Good dynamic sealing
- Very good protection against solid pollution particles
- Modern lip design provides low axial forces (low power loss)
- Small fitting width
- No supplementary retention's needed

Application examples

- Transmission systems (e.g. gearboxes)
- Pumps
- Electrical motors
- Machine tools
- Wheels and heavy-duty axles

Technical data

Pressure:	No pressure
Temperature:	-40°C to +200°C (depending on material)
Speed:	up to 20 m/s
Media:	mineral and synthetic lubricants (CLP, HLP, APGL etc.)

Trelleborg Sealing Solutions has carried out several thousands compatibility tests. Please ask for details.

Housing:	Carbon steel - chromate treated (N7MM) or zinc plated (4N04, 4V04)
	Stainless and acid-proof steel on request

Important Note:

The above data are maximum values and cannot be used at the same time, e. g. the maximum operating speed depends on material type, pressure and temperature.



GAMMA Seal

Table LII Materials

Standard material*	TSS material code	STEFA material reference	Standard metal shell**
NBR (70 Shore A)	N7MM	-	Carbon steel (chromated)
NBR (75 Shore A)	4N04	1452	Carbon steel (zinc plated)
FKM (75 Shore A)	4V04	5466	Carbon steel (zinc plated)

* Special grades and other materials (HNBR, ACM, VMQ) on request.

** Metal shell can be supplied in different material or treatment on request.

Ordering example GAMMA seal TSS type

TSS type: BP
 Code: TBP
 Dimensions: Shaft diameter 25 mm
 Housing diameter 40 mm
 Width 4 mm
 Material: NBR
 Material Code: N7MM

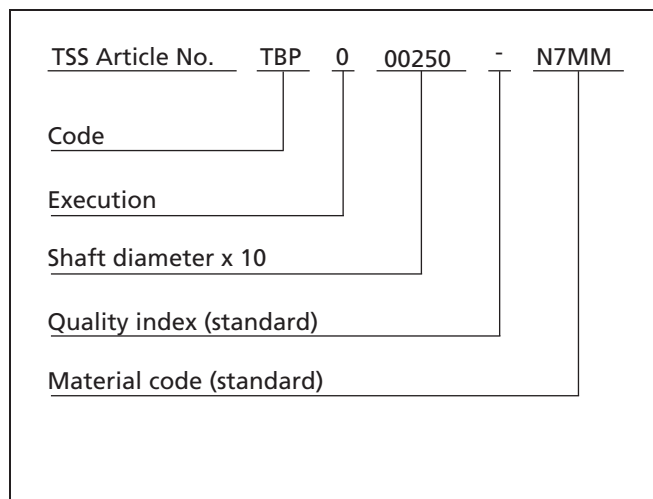

Ordering example GAMMA seal STEFA type

STEFA type: RB
 Code: TBP
 Dimensions: Shaft diameter 25 mm
 Housing diameter 40 mm
 Width 4 mm
 Material: NBR 1452
 Material Code: 4N04

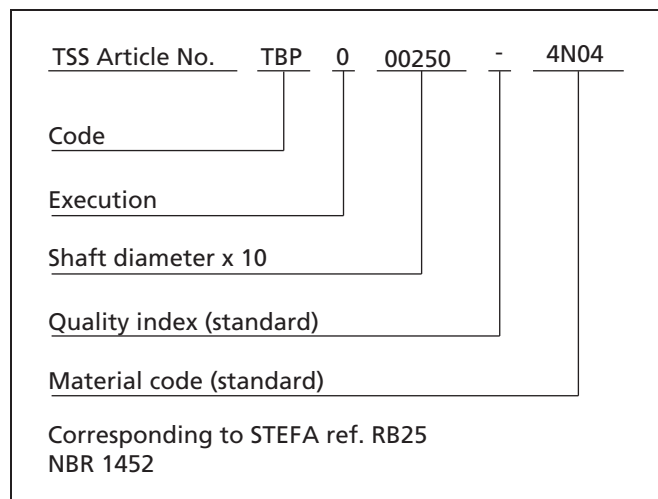

Table LIII Preferred series / Dimension, TSS part numbers

Dimension					TSS Part No.	STEFA			TSS
d ₁	d ₂	b	B ₁	d _{max}		Type	NBR 4N04	FKM 4V04	NBR N7MM
10	24	3.5	1.0	15	TBP000100	RB10	X	X	
12	26	3.5	1.0	17	TBP000120	RB12	X	X	
15	30	4	1.0	21	TBP000150	RB15	X	X	X
16	32	4	1.0	23	TBP000160	RB16	X	X	X
17	32	4	1.0	23	TBP000170	RB17	X	X	X
18	33	4	1.0	24	TBP000180	RB18	X	X	X
20	35	4	1.0	26	TBP000200	RB20	X	X	X
22	40	4	1.0	28	TBP000220	RB22	X	X	X
24	40	4	1.0	30	TBP000240	RB24	X	X	X



Dimension					TSS Part No.	STEFA			TSS
d ₁	d ₂	b	B ₁	d _{max}		Type	NBR 4N04	FKM 4V04	NBR N7MM
25	40	4	1.0	31	TBP000250	RB25	X	X	X
26	40	4	1.0	32	TBP000260	RB26	X	X	
28	43	4	1.0	34	TBP000280	RB28	X	X	X
30	47	4.5	1.0	37	TBP000300	RB30	X	X	X
32	49	4.5	1.0	39	TBP000320	RB32	X	X	
35	52	4.5	1.0	42	TBP000350	RB35	X	X	X
40	57	4.5	1.0	47	TBP000400	RB40	X	X	X
45	62	4.5	1.0	52	TBP000450	RB45	X	X	X
48	65	4.5	1.0	55	TBP000480	RB48	X	X	
50	70	5.5	1.0	58	TBP000500	RB50	X	X	X
52	72	5.5	1.0	60	TBP000520	RB52	X	X	
53	73	5.5	1.0	61	TBP000530	RB53	X	X	
55	75	5.5	1.0	63	TBP000550	RB55	X	X	X
58	78	5.5	1.0	66	TBP000580	RB58	X	X	
60	80	5.5	1.0	68	TBP000600	RB60	X	X	X
62	82	5.5	1.0	70	TBP000620	RB62	X	X	
65	85	5.5	1.0	73	TBP000650	RB65	X	X	X
68	88	5.5	1.0	76	TBP000680	RB68	X	X	
70	90	5.5	1.0	78	TBP000700	RB70	X	X	X
72	92	5.5	1.0	80	TBP000720	RB72	X	X	
75	95	5.5	1.0	83	TBP000750	RB75	X	X	X
78	98	5.5	1.0	86	TBP000780	RB78	X	X	
80	100	5.5	1.0	88	TBP000800	RB80	X	X	X
85	105	5.5	1.0	93	TBP000850	RB85	X	X	X
90	110	5.5	1.0	98	TBP000900	RB90	X	X	
95	115	5.5	1.0	103	TBP000950	RB95	X	X	
100	120	5.5	1.0	108	TBP001000	RB100	X	X	X
105	125	5.5	1.0	113	TBP001050	RB105	X	X	
125	148	6.5	1.0	133	TBP001250	RB125	X	X	
135	159	6.5	1.0	145	TBP001350	RB135	X	X	



■ GAMMA-seal type TBR/9RB

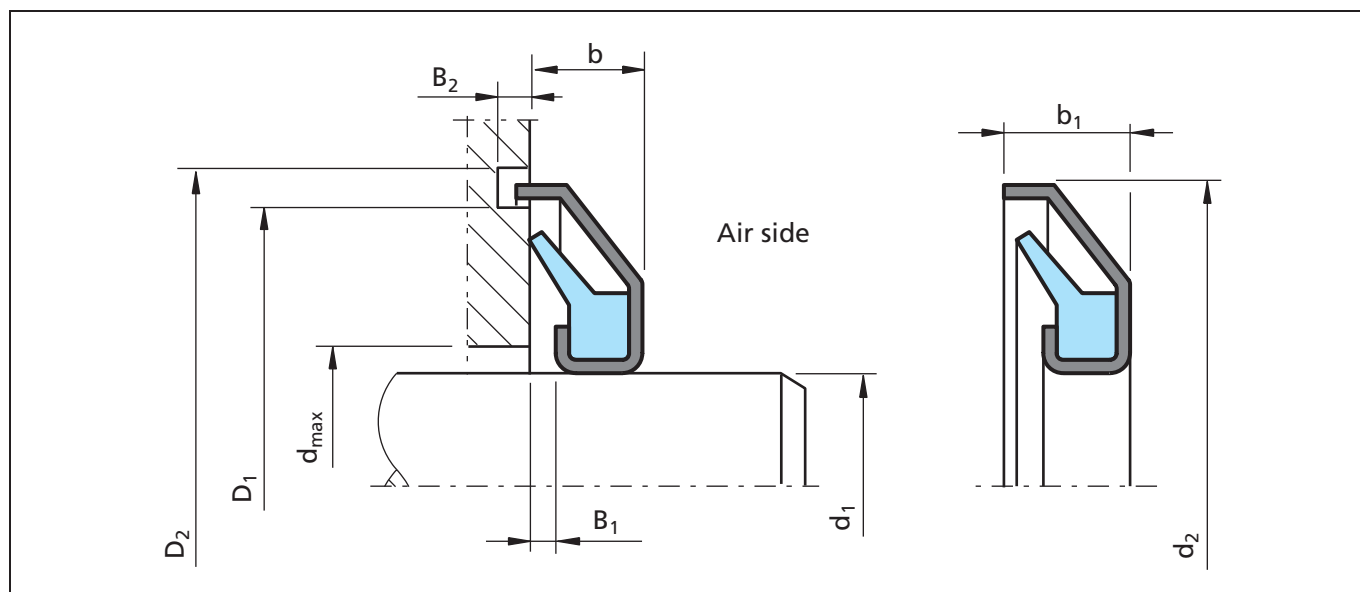

Figure 81 GAMMA-seal with labyrinth

General description

The design of the GAMMA seal TBR/9RB is based on many years of experience in such applications. The total axial force of the sealing lip is given by elastomer pre-stretching together with lip deformation force which depends on the elasticity of the rubber material, geometry of the sealing lip and assembly positioning against the counterface. The metal shell is protecting the seal from solids and contributes to exclude other pollution media by centrifusion, allowing a good drainage after immersion in liquids. The shape of the metal shell allows a supplementary barrier via the labyrinth in the housing groove which is very effective for heavy-duty applications.

Advantages

- Good dynamic sealing
- Very good protection against solid pollution particles
- Modern lip design provides low axial forces (low power loss)
- Small fitting width
- No supplementary retention's needed
- Very effective supplementary labyrinth protection

Application examples

- Transmission systems (e.g. gearboxes)
- Pumps

- Electrical motors - mixers
- Machine tools
- Wheels and heavy-duty axles

Technical data

Pressure:	No pressure
Temperature:	-40 °C to +200 °C (depending on material)
Speed:	up to 20 m/s
Media:	mineral and synthetic lubricants (CLP, HLP, APGL etc.)

Trelleborg Sealing Solutions has carried out several thousands compatibility tests. Please ask for details.

Housing :	Carbon steel - zinc plated
	Stainless and acid-proof steel on request

Important Note:

The above data are maximum values and cannot be used at the same time, e. g. the maximum operating speed depends on material type, pressure and temperature.



Table LIV Materials

Standard material*	TSS material code	STEFA material reference	Standard metal shell**
NBR (75 Shore A)	4N04	1452	Carbon Steel (zinc plated)
FKM (75 Shore A)	4V04	5466	Carbon Steel (zinc plated)

* Special grades and other compounds (HNBR, ACM, VMQ) on request.

** Metal shell can be supplied in different material or treatment on request.

Ordering example GAMMA seal STEFA type

STEFA type: 9RB
 Code: TBR
 Dimensions: Shaft diameter 25 mm
 Housing diameter 42 mm
 Width 4 mm
 Material: NBR 1452
 Material Code: 4N04

TSS Article No.	TBR	0	00250	-	4N04
Code					
Execution					
Shaft diameter x 10					
Quality index (standard)					
Material code (standard)					
Corresponding to STEFA ref. 9RB25 NBR 1452					

Table LV Preferred series / Dimension, TSS part numbers

Dimension									TSS Part No.	TSS		
d ₁	d ₂	b	B ₁	b ₁	B ₂	d _{max}	D ₁	D ₂		Type	NBR 4N04	FKM 4V04
15	32	4	1.0	6.0	3	21	29	34	TBR000150	9RB15	X	X
17	34	4	1.0	6.0	3	23	31	36	TBR000170	9RB17	X	X
20	37	4	1.0	6.0	3	26	34	39	TBR000200	9RB20	X	X
25	42	4	1.0	6.0	3	31	39	44	TBR000250	9RB25	X	X
30	48	4.5	1.0	6.5	3	37	45	50	TBR000300	9RB30	X	X
35	53	4.5	1.0	6.5	3	42	50	55	TBR000350	9RB35	X	X
40	58	4.5	1.0	6.5	3	47	55	60	TBR000400	9RB40	X	X
45	63	4.5	1.0	6.5	3	52	60	65	TBR000450	9RB45	X	X
50	72	5.5	1.0	7.5	3	58	68.5	74	TBR000500	9RB50	X	X
55	77	5.5	1.0	7.5	3	63	73.5	79	TBR000550	9RB55	X	X
60	82	5.5	1.0	7.5	3	68	78.5	84	TBR000600	9RB60	X	X
65	87	5.5	1.0	7.5	3	73	83.5	89	TBR000650	9RB65	X	X
70	92	5.5	1.0	7.5	3	78	88.5	94	TBR000700	9RB70	X	X
80	102	5.5	1.0	7.5	3	88	98.5	104	TBR000800	9RB80	X	X
85	107	5.5	1.0	7.5	3	93	103.5	109	TBR000850	9RB85	X	X



GAMMA Seal

Dimension									TSS Part No.	TSS		
d ₁	d ₂	b	B ₁	b ₁	B ₂	d _{max}	D ₁	D ₂		Type	NBR 4N04	FKM 4V04
90	112	5.5	1.0	7.5	3	98	108.5	114	TBR000900	9RB90	X	X
95	117	5.5	1.0	7.5	3	103	113.5	119	TBR000950	9RB95	X	X
100	122	5.5	1.0	7.5	3	108	118.5	124	TBR001000	9RB100	X	X

Axial Shaft Seal







■ AXIAL SHAFT SEAL

Axial shaft seals are used primarily as a protective seal for roller bearings. Their sizes are matched to those of roller bearings. If fluids are to be prevented from escaping, a design with an internal seal lip, is to be preferred.

The design with external sealing lip is suitable for sealing grease and for protection against dirt entering from the outside.

In both types of construction the elastomer seal lip is axially spring-loaded against the opposite mating face by a spider spring. The linear compressive force is lower than with an oil seal (about one third), but constant in operation. There is no reduction in contact force due to thermal expansion as with oil seals, and the larger diameter of the sliding seal edge has an unessential influence on the friction effect.

■ General

Axial shaft seals are ready-to-install seal elements for sealing shafts, axles and bearings.

The Axial shaft seal consists of an elastomer-elastic membrane with a vulcanized metallic reinforcement ring. The membrane has an axial sealing lip. The sealing lip is designed in a conical form to obtain a minimum contact area, thus considerably reducing friction, heat and wear. The sturdy form ensures a proper fit with the shaft or housing. A metallic spider spring is used to energize the seal lip (Figure 82).

Characteristics

Axial shaft seals have axial spring load against the mating surface. The seal requires very little mounting space and can be effectively used where space is limited.

Method of Operation

The sealing lip is pressed axially against the mating surface which must be perpendicular to the axis of the shaft. The seal membrane and the spider spring pressing against the back of the sealing lip ensure a uniform and vibration-free contact pressure.

The centrifugal force of fluid accelerated by the shaft reinforces the sealing effect.

Static sealing against the shaft (Type A) or in the housing bore (Type I) is ensured by interference fit with the shaft or housing.

Advantages

- Low friction, minimum heat generation
- No shaft wear
- Minimum installation space requirement
- Simple installation
- High heat resistance
- High sliding speed
- Suitable for a wide range of roller bearing series
- Long service life

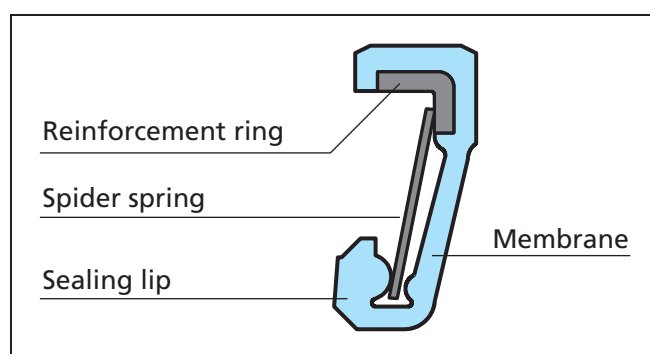

Figure 82 Axial shaft seal



Axial Shaft Seal

Standard versions

Type I

Axial shaft seal with internal sealing lip, primarily for sealing of fluids (Figure 83).

The seal is generally press fitted in the housing with the sealing lip against the rotating shaft. The seal should always be installed so that the sealing lip is flushed by the fluid. Dry running must be avoided.

The limits for speed, pressure and contact force of the sealing lip can be found in Table LIV, and Table LV.

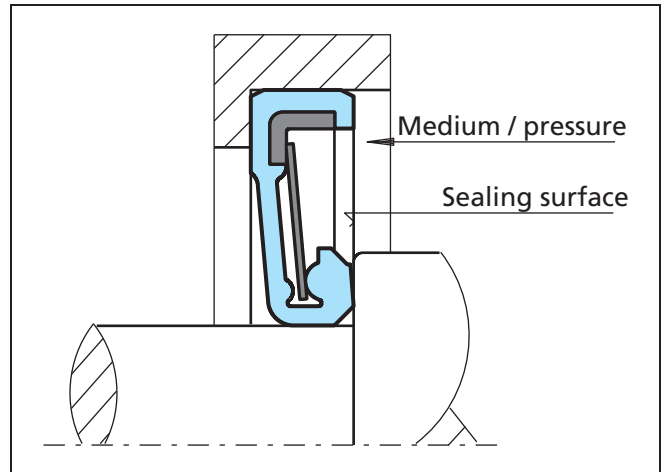

Figure 83 Type I, internal sealing

Type A

Axial shaft seal with external sealing lip for sealing against grease (Figure 84).

At low speeds and with a very good, preferably ground or lapped contact surface, it can also be used for sealing against fluids.

The limits for speed, pressure and contact force of the sealing lip can be found in Table LVI and Table LVII.

For fluid sealing, the maximum permissible speed is reduced to one-third of the value shown in the tables.

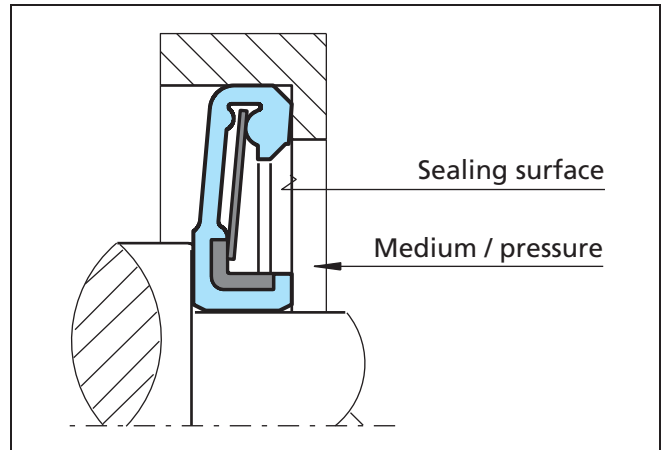

Figure 84 Type A, external sealing



■ Applications

Fields of application

Axial shaft seals are used for sealing shafts, axles and bearings. Their function is to prevent the ingress of dust, dirt, splash water, etc., and to prevent the escape of fluid or lubricant from the sealed chamber.

The fields of application of the individual types differ widely and are predominantly dependent on the type of lubricant and the operating conditions.

Technical data

Operating pressure:	No pressure
Speed:	Up to 30 m/s, depending on type and elastomer material
Temperature:	-30°C to +200°C, depending on elastomer material see Table LIII.

We offer special materials down to -40°C on request.

Media:

Mineral and synthetic oils and greases, water, hydrocarbons, acids, lye, etc. (depending on elastomer material).

Peripheral speed and rotational speed

To maintain acceptable heat generation and wear of the sealing lip, the peripheral speed must be limited according to the elastomer grade used. The peripheral speed at the sealing lip must not exceed the following values:

Type I:	with NBR	20 m/s
	with FKM	30 m/s
Type A:	with NBR	10 m/s
	with FKM	15 m/s

These values apply with adequate lubrication and heat dissipation at the seal surface. If these conditions are not satisfied, the above limits must be reduced according to the application.

Figure 85 shows the maximum speed n as a function of the average sealing lip diameter d_m for the elastomer material Acrylonitrile Butadiene Elastomer (NBR).

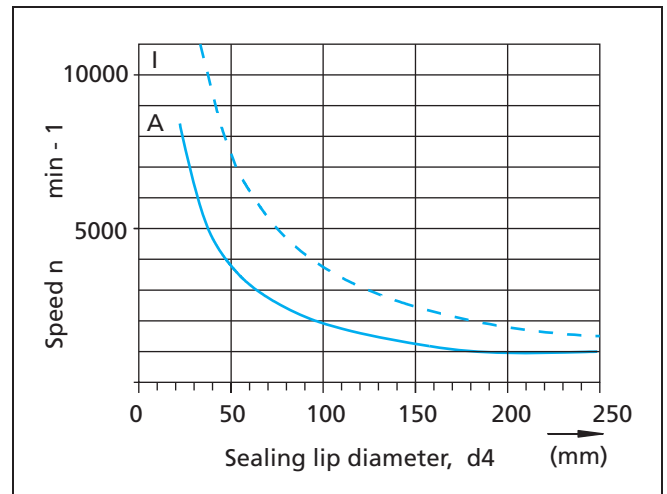

Figure 85 Maximum revolutions n as a function of sealing lip diameter d_4



Axial Shaft Seal

■ Materials

Table LVI shows the available standard materials. Materials for elastomer and metal parts are selected according to the requirements for temperature and fluid resistance.

Table LVI Materials

	Standard Materials	Material code
Elastomers Membrane and sealing lip	Acrylonitrile Butadiene Elastomer (NBR) 75 Shore A Color: black/anthracite Temperature range: - 30 °C to + 120 °C	NCM_
	Fluoroelastomer (FKM) 75 Shore A Color: anthracite (Identification mark: yellow dot) Temperature range: - 25° C to + 200° C	VCM_
Metal parts Reinforcement ring + spider spring	Reinforcement ring: Steel 1.0338/St 14.03 Star-type spring: Spring steel 1.0605/C75	_ _ _ M

Special materials are available on request.



Design instructions

The design of the sealing area should be made according to the information on the individual types given in Figure 83 and 84.

Suitable mating faces for the sealing lip can be achieved in various ways, for instance by using the hardened end face of a Roller bearing. The bearing must not have identification marks on the side used as a mating face. Other design possibilities are shaft collars, back-up washers, etc.

The mating face can be of steel, brass, bronze, aluminum alloys and ceramic materials. The mating surface must be clean and smooth without spiral grooves or scratches. Recommended surface hardness for steel is HRC > 40, for other materials lower hardness can be employed.

Surface roughness

Contact surface: with oil lubrication
 $R_{\max} < 2.5 \mu\text{m}$
($R_a \leq 1.0 \mu\text{m}$, $R_z < 1.6 \mu\text{m}$)

with grease lubrication
 $R_{\max} < 6.3 \mu\text{m}$
($R_a \leq 2.5 \mu\text{m}$, $R_z < 4.0 \mu\text{m}$)

Radial runout of the shaft has very little influence on seal efficiency.

The axial runout - at the maximum permissible rotational speed - must not exceed 0.03 mm when sealing against oil and 0.05 mm when sealing against grease.

Installation recommendation

Before installation of the seal, the sealing surface should be cleaned and greased lightly to minimize wear during the run-in phase.

Installation is, in most cases, performed "blind", i.e. uniform contact between the sealing lip and the mating face cannot be checked visually. During installation the sealing lip must not be damaged or deformed, and the seal must be installed parallel to the mating face. This is best ensured if the seal is installed against a seat in the housing with an assembly tool (Figure 86).

Optimal seal performance is obtained when the seal or mating face is positioned in line with the front end of the seal.

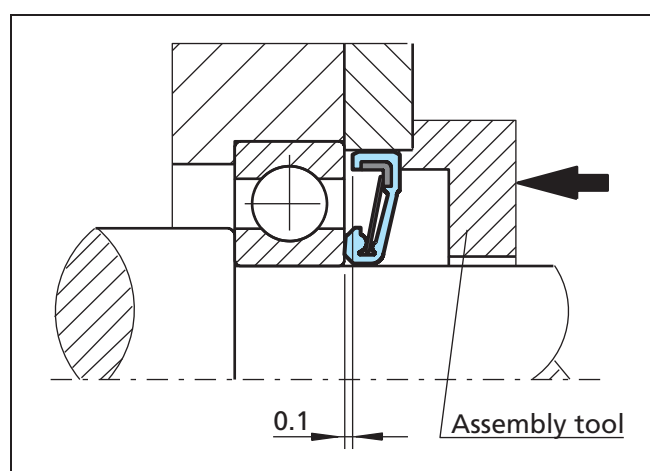

Figure 86 Installation of the axial shaft seal using an assembly tool



Axial Shaft Seal

■ Installation recommendation, type I, internal sealing, for oil and grease

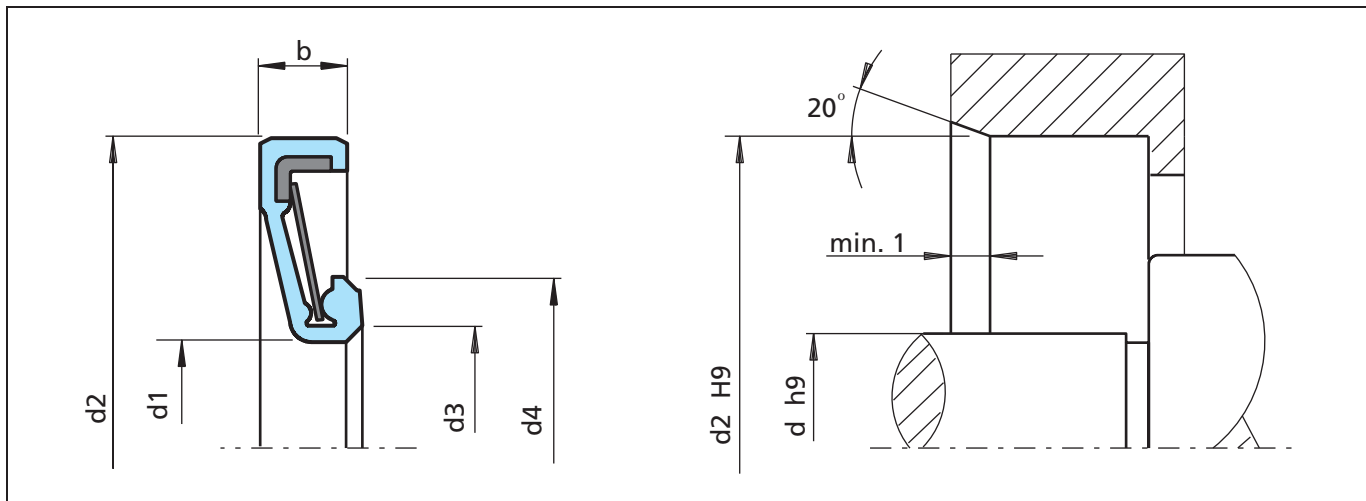

Figure 87 Installation drawing

Ordering example

Axial shaft seal, Type I
 Shaft diameter $d = 50.0$ mm
 Suitable for roller bearing No. 6010

Materials: From Table LVII, page 202:
 Membrane and sealing lip: NBR
 Material code: NCM
 Reinforcement ring: 1.0338
 + spider spring: 1.0605
 Material code: M

TSS Article No.	TAI000110	-	NCM	M
TSS Part No.				
Quality Index (Standard)				
Material No. (elastomer)				
Material No. (metal parts)				

Table LVII Preferred series

Shaft	Dimensions					Max. speed [min ⁻¹]		Fa* [N]	Max. press. [Pa]	Correspondance to the roller bearing series					TSS Part No.
	d	d ₁	d ₂	d ₃	d ₄	b	NBR			FKM	6000	6300	6400	4200	
10	11	24	12.0	13.0	4.0	25400	38000	1.8	9000	6000	6300	-	-	-	TAI000100
12	13	26	14.0	16.0	4.0	23800	35700	2.0	9400	6001	-	-	4200	-	TAI000101
15	16	30	17.0	20.0	4.5	19200	28800	2.5	9500	6002	-	-	-	4301	TAI000102
17	18	33	19.0	22.0	4.5	17500	26200	3.0	8800	6003	6302	-	-	-	TAI000103
20	22	39	23.0	26.0	4.5	14700	22000	3.5	6900	6004	6304	6403	-	-	TAI000104
25	27	44	27.5	31.0	4.5	13000	19500	3.8	6150	6005	-	6404	-	-	TAI000105
30	32	50	33.0	36.0	5.0	10600	15900	4.0	5800	6006	-	6405	-	-	TAI000106
35	37	56	38.0	41.0	5.0	9300	13900	4.5	6100	6007	6306	6406	4206	-	TAI000107
40	42	62	44.0	47.0	5.5	8100	12000	5.5	6550	6008	6307	6407	4207	-	TAI000108

* Fa = Contact force of the sealing lip

Axial Shaft Seal



Shaft	Dimensions					Max. speed [min ⁻¹]		Fa* [N]	Max. press. [Pa]	Correspondance to the roller bearing series					TSS Part No.
	d	d ₁	d ₂	d ₃	d ₄	b	NBR			FKM	6000	6300	6400	4200	
45	47	70	49.0	53.0	5.5	7200	10800	6.5	5200	6009	6308	6408	4208	-	TAI000109
50	52	75	55.5	59.0	6.0	6600	9900	7.0	4750	6010	6309	6409	4209	-	TAI000110
55	58	83	61.5	65.5	6.0	6000	9000	7.5	4450	6011	6310	-	4210	-	TAI000111
60	61	89	65.0	69.0	6.5	5500	8200	8.0	3800	6012	6311	6410	4211	-	TAI000112
65	67	94	70.0	74.0	7.0	5200	7800	9.0	4600	6013	6312	6411	4212	-	TAI000113
70	73	104	74.0	78.0	7.5	4800	7200	11.0	3800	6014	6313	6412	4213	-	TAI000114
75	78	109	80.0	84.0	7.5	4500	6700	12.0	4350	6015	6314	6413	4214	-	TAI000115
80	84	119	85.0	89.0	8.0	4300	6400	13.0	2900	6016	6315	6414	4215	-	TAI000116
85	87	124	90.0	94.0	8.0	4000	6000	14.5	3500	6017	6316	6414	4216	-	TAI000117
90	93	132	96.0	101.0	8.5	3800	5700	16.0	3050	6018	6317	6415/16	4217	-	TAI000118
95	98	137	100.0	104.5	8.5	3600	5400	17.0	3250	6019	6318	6415/16	-	-	TAI000119
100	101	142	105.0	110.0	8.5	3400	5100	18.0	3400	6020	6319	6416	4218/19	-	TAI000120
10	11	26	13.0	15.5	4.5	24600	36900	1.8	9700	6200	-	-	-	-	TAI000200
12	13	28	15.0	17.5	4.5	22200	33300	2.0	10700	6201	6300/01	-	4201	4300	TAI000201
15	16	31	18.0	21.0	4.5	18200	27300	3.0	12800	6202	6302	-	4202	-	TAI000202
17	18	36	21.0	23.0	5.0	16600	24900	3.8	8100	6203	6303	-	4203	4302.0	TAI000203
20	21	41	23.0	26.0	5.5	14700	22000	4.2	7400	6204	6304	6403	4204	4303	TAI000204
25	26	46	28.0	30.0	5.5	12700	19000	4.3	6400	6205	-	6403	-	4304	TAI000205
30	32	56	34.5	37.5	6.0	10300	15400	4.6	4900	6206	-	6405	-	4305	TAI000206
35	37	65	41.0	44.0	6.5	8900	13300	5.0	3300	6207	6306/07	6405/06	-	4306	TAI000207
40	42	73	46.5	50.0	6.5	7600	11400	6.0	3200	6208	6308	6407	-	4307	TAI000208
45	47	78	51.5	56.0	6.5	7000	10500	6.5	3000	6209	6308/09	6407/08	-	4308	TAI000209
50	53	83	56.5	59.5	6.5	6400	9600	7.0	3000	6210	6309	6408/9	-	4309	TAI000210
55	58	90	61.0	65.0	7.0	5900	8800	7.5	2750	6211	6310	6409/10	-	4310	TAI000211
60	63	100	65.5	69.0	8.0	5500	8200	8.0	2100	6212	6311	6410/11	-	4311	TAI000212
65	68	110	72.0	77.0	8.5	5000	7500	9.0	2000	6213	6312	6411/12	-	-	TAI000213
70	72	115	74.0	79.0	8.5	4800	7200	10.5	2000	6214	6313	6411/12	-	4312	TAI000214
75	78	120	83.0	88.0	8.5	4400	6600	11.0	2100	6215	6313/14	6413/14	-	4313	TAI000215
80	84	128	90.0	94.0	9.0	4100	6100	13.0	2400	6216	6314/15	6414	-	4314	TAI000216
85	87	138	91.0	96.0	9.5	3900	5800	14.5	2100	6217	6315/16	6414/15	-	4315	TAI000217
90	94	148	96.5	101.5	10.0	3700	5500	16.5	2000	6218	6316	6415/16	-	-	TAI000218
95	98	158	103.0	108.0	10.0	3500	5200	17.0	2000	6219	6317/18	6415/16	-	4316	TAI000219
100	104	168	109.0	114.0	10.5	3300	4900	19.0	2100	6220	6318	6416	-	4318	TAI000220

* Fa = Contact force of the sealing lip



Axial Shaft Seal

Table LVIII Special sizes for type I

Shaft	Dimensions					Max. speed [min ⁻¹]		Fa*	Max. pressure	TSS Part No.
	d	d ₁	d ₂	d ₃	d ₄	b	NBR	FKM	[N]	
6	6,5	17	7,5	9,0	3,5	45000	67000	5,0	43500	TAI000006
7	7,5	17	8,5	10,6	3,5	40000	60000	4,5	48000	TAI000007
8	8,5	20	9,5	11,2	4,0	35000	52000	4,0	35600	TAI000008
9	9,6	22	11,0	13,0	4,0	30000	45000	4,5	27700	TAI000009
23	24,5	44	24,5	31,0	4,5	13500	20000	5,0	9300	TAI100105
26	28,0	52	28,5	32,5	5,5	12000	18000	9,0	13000	TAI200205
30	32,0	63	35,5	38,5	5,5	9800	14700	16,0	13000	TAI100306
35	37,0	56	37,0	42,0	5,0	9500	14000	5,0	8000	TAI100107
45	46,5	83	50,0	54,0	6,0	7100	10600	11,0	4300	TAI100309
70	72,0	115	75,0	80,0	8,5	4700	7000	12,0	2800	TAI100214
72	75,5	128	78,5	83,5	9,0	4500	6700	17,0	2800	TAI100314
75	77,5	125	81,0	86,0	8,5	4400	6600	12,0	2500	TAI100215
80	83,0	130	84,0	90,0	9,0	4200	6300	13,0	2900	TAI100216
93	98,0	150	100,0	106,0	10,0	3600	5400	17,0	2350	TAI100218
105	108,0	150	114,0	119,0	9,0	3300	5000	12,0	2000	TAI100121
110	114,0	160	120,0	125,0	9,0	3100	4600	15,0	2000	TAI100122
110	113,0	190	121,0	126,0	9,5	3000	4500	38,0	5600	TAI100320
110	117,0	190	124,0	129,0	9,5	2900	4300	20,0	1300	TAI100221
120	125,0	170	129,0	134,0	9,0	2900	4300	20,0	3050	TAI100124
130	135,0	200	140,0	146,0	9,5	2600	3900	35,0	4800	TAI100324
130	134,0	190	140,0	146,0	9,5	2600	3900	19,0	1750	TAI100126
140	143,0	200	148,0	154,0	9,5	2500	3700	32,0	2850	TAI100128
150	155,0	270	160,0	167,0	11,0	2200	3300	30,0	2500	TAI100328
150	154,0	215	160,0	166,0	10,0	2300	3400	26,0	2000	TAI100130
160	164,0	230	175,0	181,0	10,0	2100	3100	40,0	2700	TAI100132
170	176,0	250	180,0	186,0	11,0	2050	3000	37,0	1900	TAI100134
220	226,0	328	230,0	240,0	13,0	1550	2300	35,0	2200	TAI100144
240	247,0	348	249,0	257,0	13,0	1500	2250	38,0	1000	TAI100148
285	290,0	360	294,0	298,0	13,0	1300	1950	33,0	1350	TAI100156
330	336,0	420	338,0	344,0	13,0	1100	1650	32,0	1000	TAI100166
380	385,0	460	390,0	398,0	13,0	950	1400	30,0	1100	TAI100176

* Fa = Contact force of the sealing lip



■ Installation recommendation, type A, external sealing, for grease only

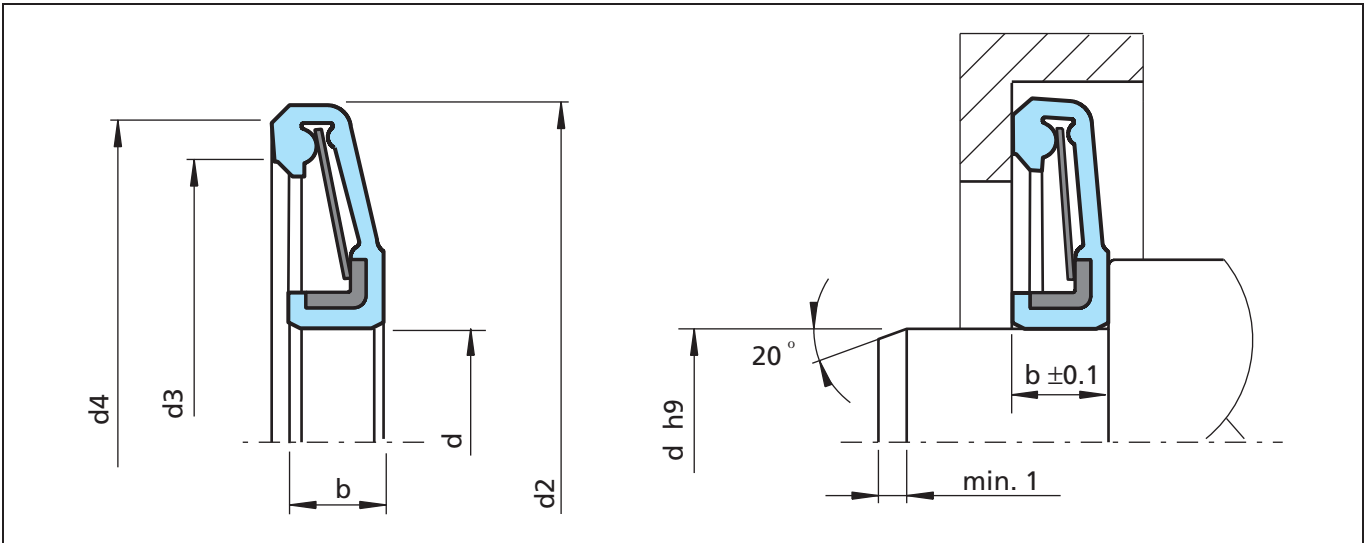

Figure 88 Installation drawing

Ordering example

Axial shaft seal, Type A
 Shaft diameter $d = 50.0$ mm
 Suitable for roller bearing No. 6009

Materials: From Table LIII, page 202:
 Membrane and sealing lip: NBR
 Material code: NCM
 Reinforcement ring: 1.0338
 + spider spring: 1.0605
 Material code: M

TSS Article No.	TAA000109	-	NCM	M
TSS Part No.				
Quality index (standard)				
Material no. (elastomer)				
Material no. (metal parts)				

Table LIX Preferred series

Shaft d	Dimensions				Max. speed [min ⁻¹]		Fa* [N]	Max. press. [Pa]	Correspondance to the roller bearing series					TSS Part No.
	d ₂	d ₃	d ₄	b	NBR	FKM			6000	6300	6400	4200	4300	
12	25.0	22.0	24.5	3.5	7900	11800	2.0	10000	6000	-	-	-	-	TAA000100
14	27.0	24.0	26.5	3.5	7300	11000	2.0	7500	6001	-	-	-	-	TAA000101
17	31.0	27.5	30.0	4.0	6300	9400	3.0	10000	6002	-	-	-	-	TAA000102
19	35.0	30.0	33.0	4.0	5900	8800	3.5	10000	6003	6300	-	-	-	TAA000103
23	40.5	30.5	38.5	4.5	4900	7300	4.0	6600	6004	6302	-	-	-	TAA000104
28	45.5	41.5	44.0	4.5	4300	6400	4.5	5750	6005	-	-	-	-	TAA000105
35	53.0	47.5	50.5	4.5	3800	5700	5.0	5400	6006	-	-	-	-	TAA000106
40	61.0	54.0	58.0	4.5	3300	4900	5.5	4400	6007	6305	-	-	-	TAA000107
45	68.5	59.5	63.5	5.0	3000	4500	6.0	4000	6008	-	6404	-	-	TAA000108

* Fa = Contact force of the sealing lip



Axial Shaft Seal

Shaft	Dimensions				Max. speed [min ⁻¹]		Fa* [N]	Max. press. [Pa]	Correspondance to the roller bearing series					TSS Part No.
	d	d ₂	d ₃	d ₄	b	NBR			FKM	6000	6300	6400	4200	
50	74.0	66.5	70.5	5.0	2700	4000	6.5	3400	6009	6307	6405	-	-	TAA000109
55	77.0	71.0	75.0	5.5	2500	3700	7.0	3650	6010	-	-	-	-	TAA000110
61	87.0	80.5	84.5	6.0	2250	3400	8.0	3100	6011	6309	6407	-	-	TAA000111
66	93.0	85.0	89.0	6.0	2150	3200	9.0	3300	6012	-	-	-	-	TAA000112
71	97.0	90.5	94.5	6.0	2000	3000	10.0	3200	6013	-	6408	-	-	TAA000113
76	106.0	99.0	103.0	6.5	1800	2700	11.0	3000	6014	6310	-	-	-	TAA000114
81	112.0	103.0	108.0	7.0	1700	2550	12.5	3700	6015	6311	6409	-	-	TAA000115
86	122.0	112.0	117.0	7.5	1600	2400	14.0	2950	6016	6312	6410	-	-	TAA000116
91	127.0	118.0	123.0	7.5	1550	2300	15.0	2900	6017	-	6411	-	-	TAA000117
98	137.0	128.0	133.0	8.0	1450	2150	16.0	2750	6018	6314	6412	-	-	TAA000118
103	142.0	132.0	137.0	7.5	1400	2100	18.0	2850	6019	6314	6412	-	-	TAA000119
108	147.0	137.0	142.0	8.5	1350	2000	19.0	2900	6020	6315	6413	-	-	TAA000120
14	29.5	25.0	28.5	4.0	7000	10500	2.0	6000	6200	-	-	4200	-	TAA000200
16	31.5	26.0	29.0	4.0	6500	9700	2.0	4700	6201	-	-	4201	4300	TAA000201
19	33.0	29.5	32.0	4.0	6400	9600	3.0	8150	6202	6300	-	4202	4301	TAA000202
21	38.5	34.5	37.0	4.0	4900	7300	3.5	5950	6203	-	-	4203	4302	TAA000203
25	46.5	40.0	43.0	4.5	4400	6600	4.0	4450	6204	6303	-	4204	4303	TAA000204
31	50.5	45.5	48.5	5.0	3900	5800	4.5	4500	6205	6304	-	4205	-	TAA000205
36	60.0	54.0	58.0	5.5	3300	4900	5.0	3400	6206	6305	6404	4206	4305	TAA000206
42	68.0	61.5	65.5	6.0	2900	4300	5.5	2700	6207	6306	-	4207	4306	TAA000207
47	77.0	69.5	73.5	6.0	2600	3900	6.0	2200	6208	6307	6405	4208	4307	TAA000208
52	82.0	74.5	78.5	6.5	2400	3600	6.5	2450	6209	6308	6406	4209	4308	TAA000209
57	86.0	79.0	83.0	7.0	2300	3400	7.0	2450	6210	-	6407	4210	-	TAA000210
64	97.0	88.0	92.0	7.5	2100	3100	8.0	2300	6211	6309	6408	4211	4309	TAA000211
69	106.0	98.0	102.0	8.0	1800	2700	9.0	1900	6212	6310	6409	4212	4310	TAA000212
74	116.0	105.0	110.0	8.5	1700	2550	10.0	1700	6213	6311	6410	4213	4311	TAA000213
80	120.5	109.0	114.0	8.5	1650	2450	11.0	2000	6214	6312	-	4214	4312	TAA000214
85	126.0	115.0	120.0	9.0	1600	2400	12.5	2100	6215	6312	-	4215	4313	TAA000215
92	136.0	125.0	130.0	9.0	1450	2150	14.0	2050	6216	6313	6411	4216	4314	TAA000216
97	145.0	134.0	139.0	9.0	1350	2000	15.0	2100	6217	6314	6412	4217	4315	TAA000217
102	156.0	144.0	149.0	9.5	1250	1850	16.0	1600	6218	6315	6413	4218	4316	TAA000218
108	166.0	154.5	159.0	9.5	1200	1800	18.0	1600	6219	6316	6415	4219	4317	TAA000219
114	175.0	164.0	169.0	10.0	1100	1650	18.5	1500	6220	6317	6416	4220	4318	TAA000220

* Fa = Contact force of the sealing lip



Table LX Special sizes for type A

Shaft d	Dimensions				Max. speed [min ⁻¹]		Fa*	Max. pressure	TSS Part No.
	d₂	d₃	d₄	b	NBR	FKM	[N]	[Pa]	
50	90	83,5	87,5	6,5	2200	3300	6.0	1500	TAA100209
66	93	85,0	93,0	6,0	2000	3000	15.0	7000	TAA100112
85	142	134,0	140,0	8,0	1300	1950	10.0	1000	TAA100215
85	111	103,0	108,0	7,0	1700	2550	16.0	7000	TAA100115
110	155	144,0	149,0	9,0	1200	1800	17.0	2800	TAA100220
120	165	153,0	158,0	9,0	1200	1800	16.0	2000	TAA100122
130	175	165,0	170,0	9,0	1100	1650	16.0	2000	TAA200124
130	172	162,0	168,0	9,0	1100	1650	40.0	5300	TAA300124
130	160	151,0	157,0	7,0	1200	1800	12.0	3100	TAA100124
150	208	195,0	200,0	10,0	950	1400	63.0	4400	TAA100128
160	253	245,0	250,0	8,0	750	1100	36.0	1500	TAA300130
160	252	236,0	243,0	10,0	750	1100	32.0	1000	TAA100130
162	184	177,0	181,0	6,0	1500	1500	52.0	8300	TAA100162
180	214	209,0	213,0	6,0	900	1350	30.0	4000	TAA100134
252	348	332,0	340,0	13,0	550	800	32.0	1000	TAA100148

* Fa = Contact force of the sealing lip



Axial Shaft Seal

Turcon[®] Varilip[®] PDR







■ Turcon® Varilip® PDR

■ Introduction

Turcon® Varilip® PDR rotary shaft seals extend the boundaries imposed by elastomer radial shaft seals, utilizing advanced materials and design techniques to provide optimum sealing performance for each application. The outcome is a superior sealing solution, which retains a compact seal envelope.

Standard elastomeric rotary shaft seals have a limited application range with respect to temperature, surface speed, media compatibility, pressure or a combination of these due to the inherent limitations of the various elastomer grades. Furthermore they only have a limited suitability for applications with inadequate lubrication.

Turcon® Varilip® PDR rotary shaft seals are characterized in particular by the low friction and their stick-slip-free running, reducing the temperature generation and permitting higher peripheral speeds.

Turcon® has the characteristic of inherent memory, whereby a distorted Turcon® component will attempt to recover to the profile it had during the sintering cycle of its manufacturing process. This feature is used to provide the necessary radial loading of the sealing lip onto the shaft, negating the requirement for the energizing spring present in elastomeric seal designs.

■ Description

Turcon® Varilip® PDR seals are constructed from only two parts - a precision manufactured metal body and a mechanically retained Turcon® sealing element. Unlike seals with pressed metal cases, a gasket is not required to provide sealing between the lip and casing. This is provided by the mechanical retention of the lip, improving both the chemical resistance and temperature range of the sealing system.

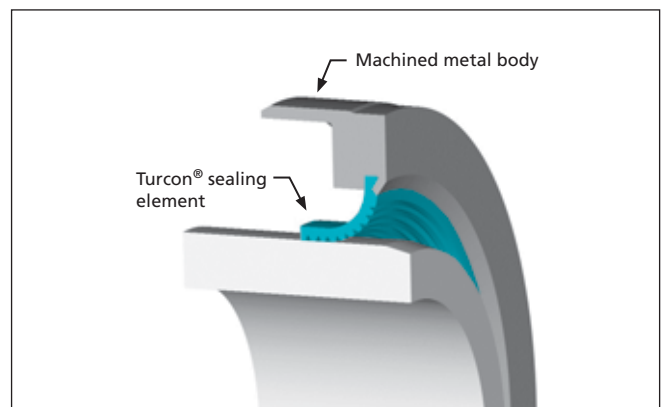

Figure 89 Turcon® Varilip® PDR seal

Where required, the Turcon® Varilip® PDR seal is available with a hydrodynamic feature on the Turcon® sealing lip. This provides a positive displacement of the fluid as a result of the shaft rotation to give improved sealing in applications where the shaft only rotates in a single direction. The feature also increases the flexibility of the lip, which allows a wider contact band between the Turcon® lip and the shaft and helps to reduce shaft load and associated wear temperature.

The mechanical retention of the Turcon® provides a robust product which also eliminates the sometimes environmentally hazardous process of bonding the Turcon® to a metal or elastomer substrate.



■ Turcon® Varilip® PDR Product Range

Table LXI Seal configurations

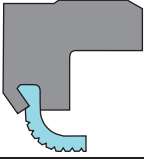
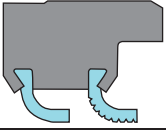
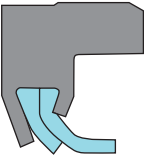
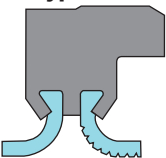
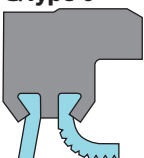
Seal	Description
Type A/Type 1 	Type A - is a single lip seal suitable for use in standard industrial applications up to a pressure of 0.5 MPa (73 psi) where an elastomer radial shaft seal would be unable to withstand the temperature, friction, medium or poor lubrication. Allows sealing at surface speeds up to 90 m/s (17,721 ft/min) with sufficient cooling and lubrication of the sealing lip.
Type B/Type 3 	Type B - is the preferred choice for applications in which a high seal integrity is demanded or where contaminated media are to be sealed. This type offers a back-up sealing lip to provide secondary sealing. Pressure limit is 0.5 MPa (73 psi).
Type C/Type 4 	Type C - can be used for applications involving higher pressures for which a simple elastomer radial shaft seal can no longer be considered. Due to reinforcement of the sealing lip, pressures up to 1 MPa (145 psi) are possible, e.g. as pump, shaft or rotor seals.
Type D/Type 5 	Type D - can be subjected to pressure from both sides. Pressure differential of up to 0.5 MPa (73 psi) is permissible. The separation of two different media using a single seal is possible. The second lip can also take on the function of a wiper or dust lip.
Type G/Type 6 	Type G - is similar to Type D but has a non-contacting environmental sealing element rather than a full lay-down lip. This provides effective sealing against the ingress of dust and dirt into the system while also ensuring torque and resulting power consumption are kept to a minimum.



Turcon® Varilip® PDR - Special designs

Apart from the standard range, Turcon® Varilip® PDR seals are available as special designs to satisfy the demands of specific applications and can accommodate non-standard housing and shaft sizes. Figures 90 to 93 show some of the special designs available.

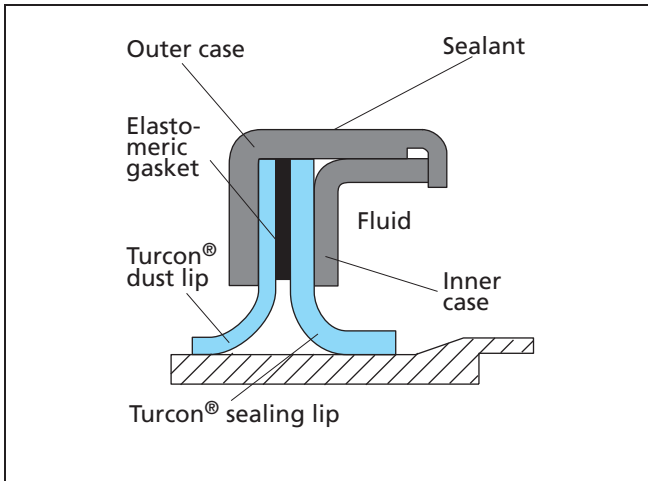

Figure 90 Clamped design

Suited to high volume applications with excessive housing tolerance

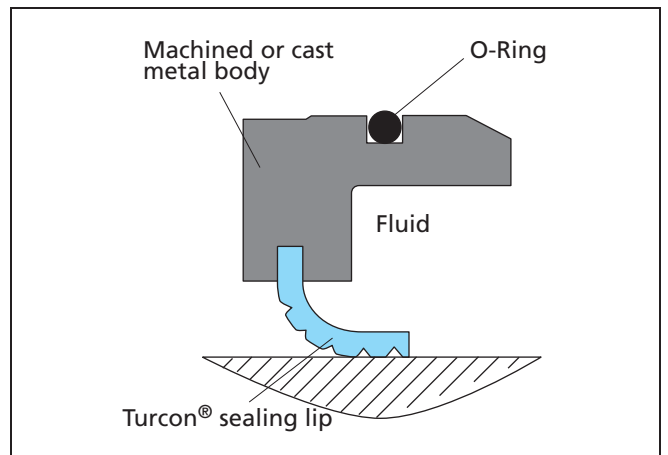

Figure 91 O-Ring design

For low interference fits in the housing

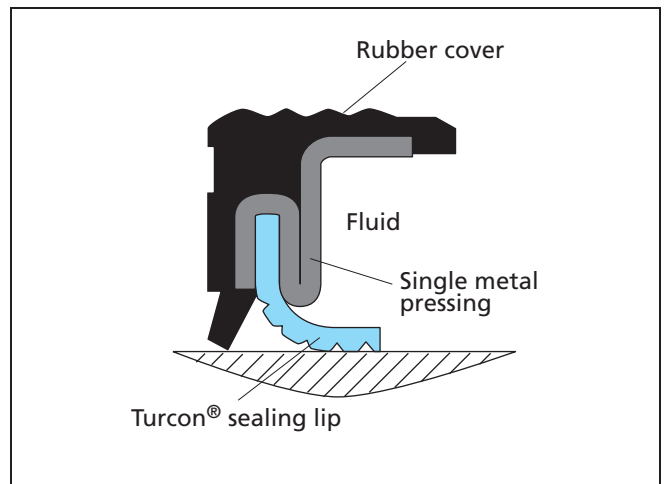

Figure 92 Single shell design

Rubber cover for poor housing surface finish at low press-in loads

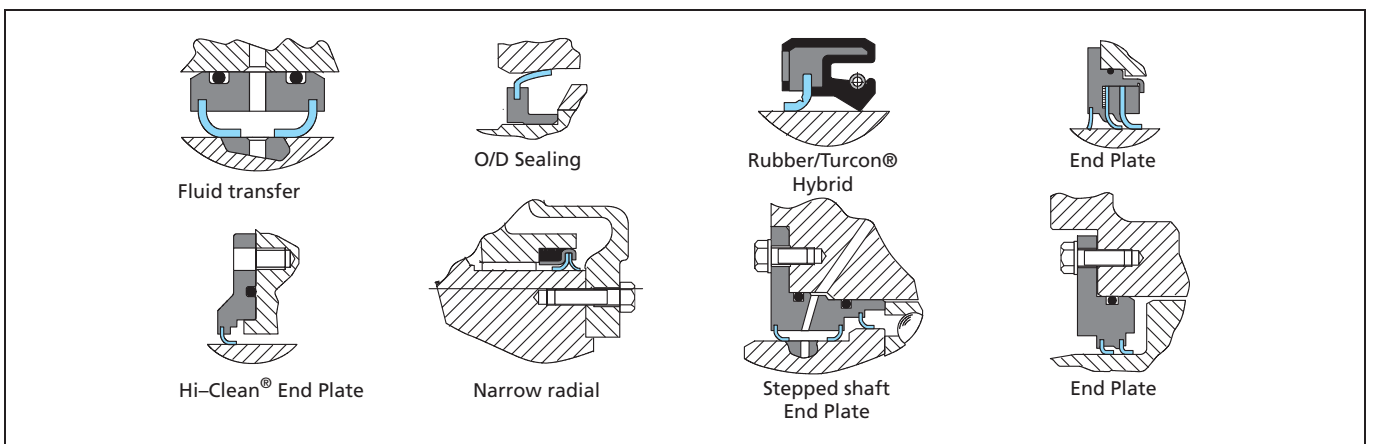

Figure 93 Variants



■ **Materials**

Sealing lip

An important factor for the proper function of rotary shaft seals is the material used for the sealing lip. For this reason, Trelleborg Sealing Solutions has developed a range of specially modified materials on the basis of the proven Turcon® materials. Particular importance is attached to the optimization of friction and wear properties, while providing excellent sealing performance, even at high peripheral speeds.

Table LXII gives the materials available for use in Turcon® Varilip® PDR seals. Additional compounds have been developed for specific applications and these are available on request.

Table LXII Sealing Element Materials

Material, Applications, Properties	Code	Operating temp.		Mating surface hardness	MPa/psi max.
		°C	°F		
Turcon® T25 Standard material with exceptional wear and friction characteristics. For lubricated running, e.g. oil, grease, glass fiber, lubricant Color: Grey	T25	-60 to +200	-76 to +392	Min. 55 HRc At low pressure and up to 4 m/s (788 fpm), min.45 HRc	2 MPa 290 psi
Turcon® T40 For all lubricating and non-lubricating fluids, especially water. Used for medium hard shafts in applications where there is risk of shaft wear. Carbon fiber Color: Grey	T40	-60 to +200	-76 to +392	Min. 30 HRc	2 MPa 290 psi
Turcon® T78 Particularly good running behavior permits use with dry running or poor lubrication and in conjunction with soft shaft surfaces e.g. stainless steel shafts in food, pharmaceutical and chemical industries. Aromatic polymer. Color: Tan to dark brown	T78	-60 to +200	-76 to +392	Min. 55 HB	0.2 MPa 29 psi
Turcon® M83 Specially designed for dry-running applications. Particularly good results in applications for the semicon industry. Can also be used lubricated. Glass fiber, pigment Color: Yellow	M83	-60 to +200	-76 to +392	Min. 55 HRc	2 MPa 290 psi

Other Turcon® materials are available by using the relevant material code when ordering. FDA compliant materials available on request.



Metal body

Turcon® Varilip® PDR seals are available with a preferred material choice of Stainless Steel 304L. Other materials such as Stainless Steel 316L and Zinc-Plated Mild Steel are available within the standard range. Table LXIII shows the codes for these materials. Other specialized materials are available on request. It should be noted that any material other than Stainless Steel 304L will result in extended lead-time due to stocking and / or additional process issues.

Table LXIII Metal Body Materials

Code	Material
1	Stainless Steel 304
2	Stainless Steel 316
3	Unavailable
4	Mild Steel (Zinc Plated)
5	Aluminum



Highlighted materials are preferred.



■ Technical Data

Speed

The graph in Figure 94 shows the superior surface speed capability of Turcon® Varilip® PDR compared to elastomeric shaft seals.

The operating speed directly impacts the temperature generated by the seal and is an important factor when considering the requirements for the sealing system.

The actual limiting speed will depend on the temperature, pressure, media, lubrication properties, heat dissipation and the shaft condition.

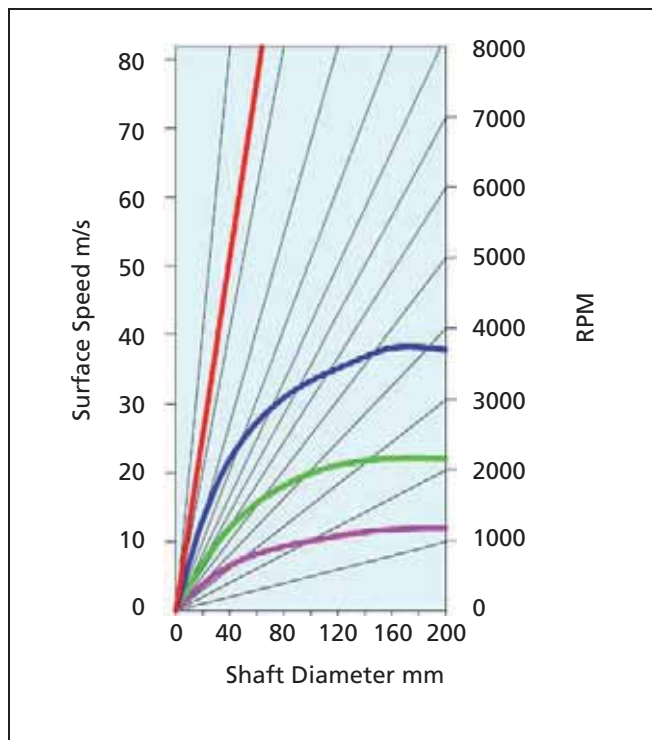

Figure 94 Surface speed as a function of shaft diameter and RPM

Table LXIV Surface Speed

General Recommended maximum Surface Speed			
Turcon® Varilip® PDR		100 m/s	19,680 ft/min
Fluoroelastomer		38 m/s	7,500 ft/min
Silicone		38 m/s	7,500 ft/min
Polyacrylic		22 m/s	4,320 ft/min
Nitrile		12 m/s	2,340 ft/min

Speed capability depends on application conditions

Temperature

All Turcon® Varilip® PDR seals are capable of outstanding high and low temperature performance compared to elastomeric materials.

Unlike other PTFE lip seals the Turcon® Varilip® PDR seal is not limited in its temperature performance by the presence of an elastomer gasket. This gives it excellent temperature range capability.

The temperatures in Figure 95 are general working limits of the seal material, and in all cases the effective limit for a rotary shaft seal application would be much lower.

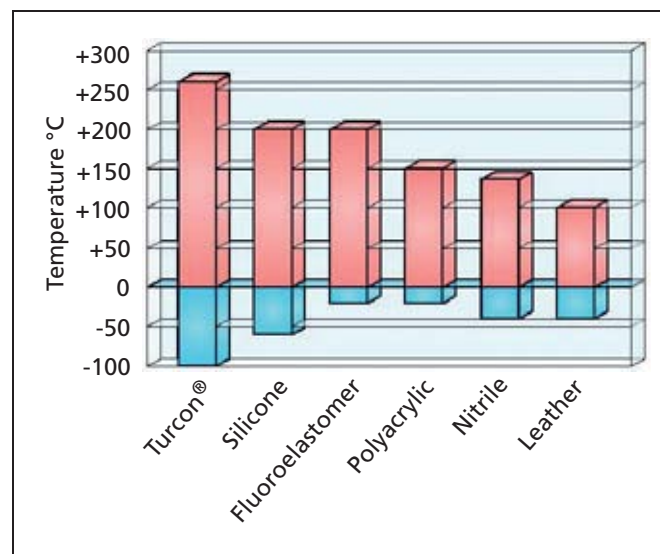

Figure 95 Maximum and minimum temperatures for different materials

Table LXV Temperature

General Recommended minimum / maximum temperature		
Filled PTFE	-100 to +260°C	-148 to +500°F
Fluoroelastomer	-20 to +200°C	-4 to +392°F
Silicone	-60 to +200°C	-76 to +392°F
Polyacrylic	-20 to +150°C	-4 to +300°F
Nitrile	-40 to +135°C	-40 to +275°F
Leather	-40 to +100°C	-40 to +212°F



Pressure

Turcon® Varilip® PDR Types A, B, D and G are suitable for pressures up to 0.5 Mpa (73 psi). Type C provides a double sealing lip design for pressures up to 1 Mpa (145 psi).

Pressure heavily influences the contact force between the Turcon® lip and the shaft and consequently the heat generation. This must be taken into consideration when selecting the appropriate seal type.

Turcon® Varilip® PDR seals can remain leak tight when exposed to pressurization during static shaft conditions.

Fluid resistance

Turcon® consists of fully substituted carbon-carbon chains and the resulting carbon-fluorine bonds are among the strongest known in organic chemistry. The outstanding physical and chemical properties of Turcon® can be attributed to these strong bonds.

Turcon® Varilip® PDR seals are resistant to mineral acids, bases, common organic fluids and solvents. They are also unaffected by oxidation, ultraviolet radiation or ozone, making them ideally suited for use in the chemical industry and applications requiring exposure to the atmosphere.

A particular benefit of Turcon® Varilip® PDR seals is a resistance to oil additives and biofuels, which have an adverse effect on many elastomers. Using Turcon® shaft seals allows the increased use of additives and a longer oil service life.

Many Turcon® materials have been successfully tested in 20 percent Fluorine gas at temperatures in excess of 250°C (482°F).

Lubrication starvation

Turcon® Varilip® PDR shaft seals have the capability to run without lubrication for longer periods of time compared with elastomer shaft seals without adversely affecting their ultimate life. This not only allows them to be used in applications where the lubrication may be intermittent as a result of start up or other operating factors, but also allows their use as effective dirt, dust and powder seals.

Note: Higher speeds and pressure capabilities can be achieved through the use of custom designs. Please consult your local Trelleborg Sealing Solutions marketing company.



Power consumption

One of the key features of Turcon® Varilip® PDR is its low friction, resulting in very low power consumption.

Figure 96 shows the running torque for a 40 mm (1.73 in) shaft diameter Turcon® Varilip® PDR seal.

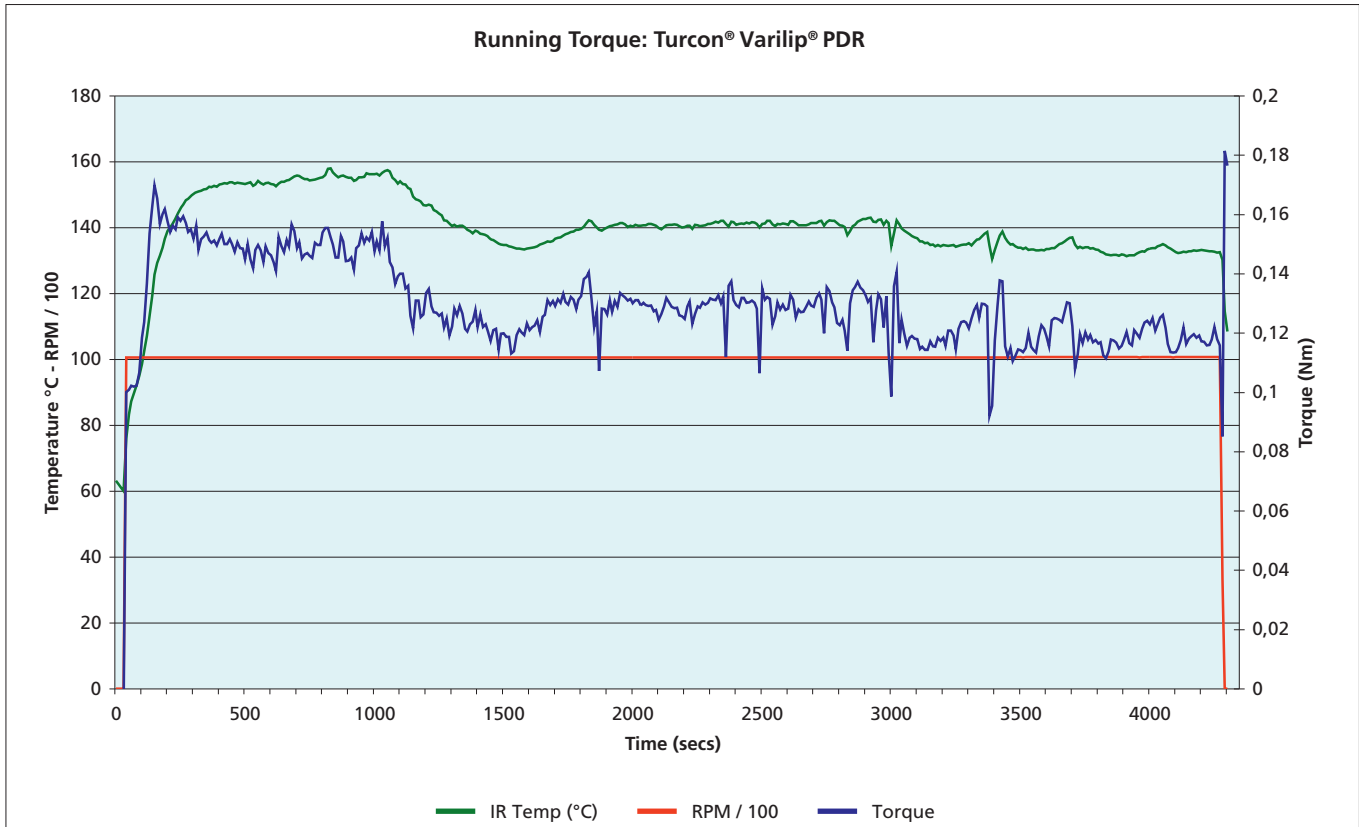

Figure 96 Running torque for Turcon® Varilip® PDR seal

Reduced torque can be achieved through custom designs but may reduce leak tightness.

Note: Results may vary according to application and conditions.



Endurance



Turcon® Varilip® PDR rotary shaft seals can provide extended service life compared with elastomer shaft seals. As with any seal, however, the life of a Turcon® Varilip® PDR seal depends on the specific operating parameters.

PTFE is an inherently stable material and does not suffer from aging or degradation as with elastomers.

Eccentricity

The graph in Figure 97 shows the maximum recommended operating envelope for silicone, nitrile, polyacrylic and fluoroelastomer seals. Turcon® Varilip® PDR seals have a specific lip design to minimize the risk of leakage and increased wear rates. Therefore the levels of eccentricity should be kept within the limits shown. In order to achieve a uniform radial load of the sealing lip on the shaft, the best possible coaxiality, or static offset should be maintained between the housing bore and the shaft, as shown in Figure 98.

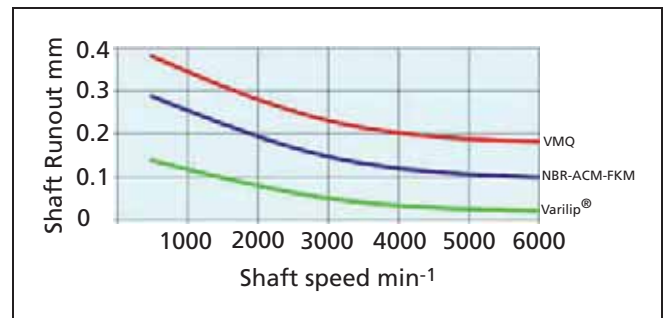

Figure 97 Dynamic eccentricity capability

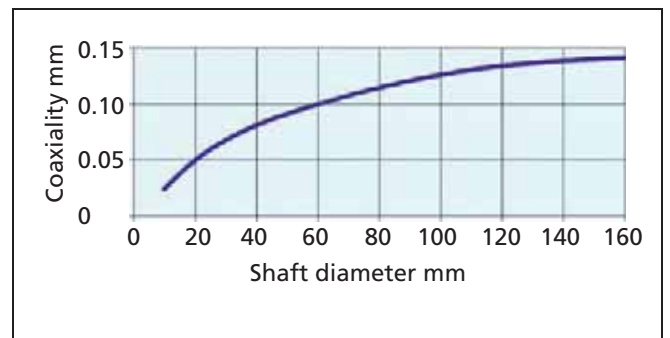

Figure 98 Coaxial tolerance capability



Leakage expectation

The hydrodynamic feature available on Turcon® Varilip® PDR helps to ensure improved leak tightness compared to other PTFE lip seals. Note that seals with hydrodynamic features must be used only in one direction.

The following graphs show the results obtained from 200 hour tests. These tests compared the leakage performance of the Turcon® Varilip® PDR seal against two competitors' PTFE lip seals. The results obtained are shown below.

Figure 99 details the leakage rate measured at regular intervals throughout the test. Figure 100 plots a cumulative graph to indicate total leakage. It can be noted that the Turcon® Varilip® PDR outperforms the two competitor seals with regard to leakage performance.

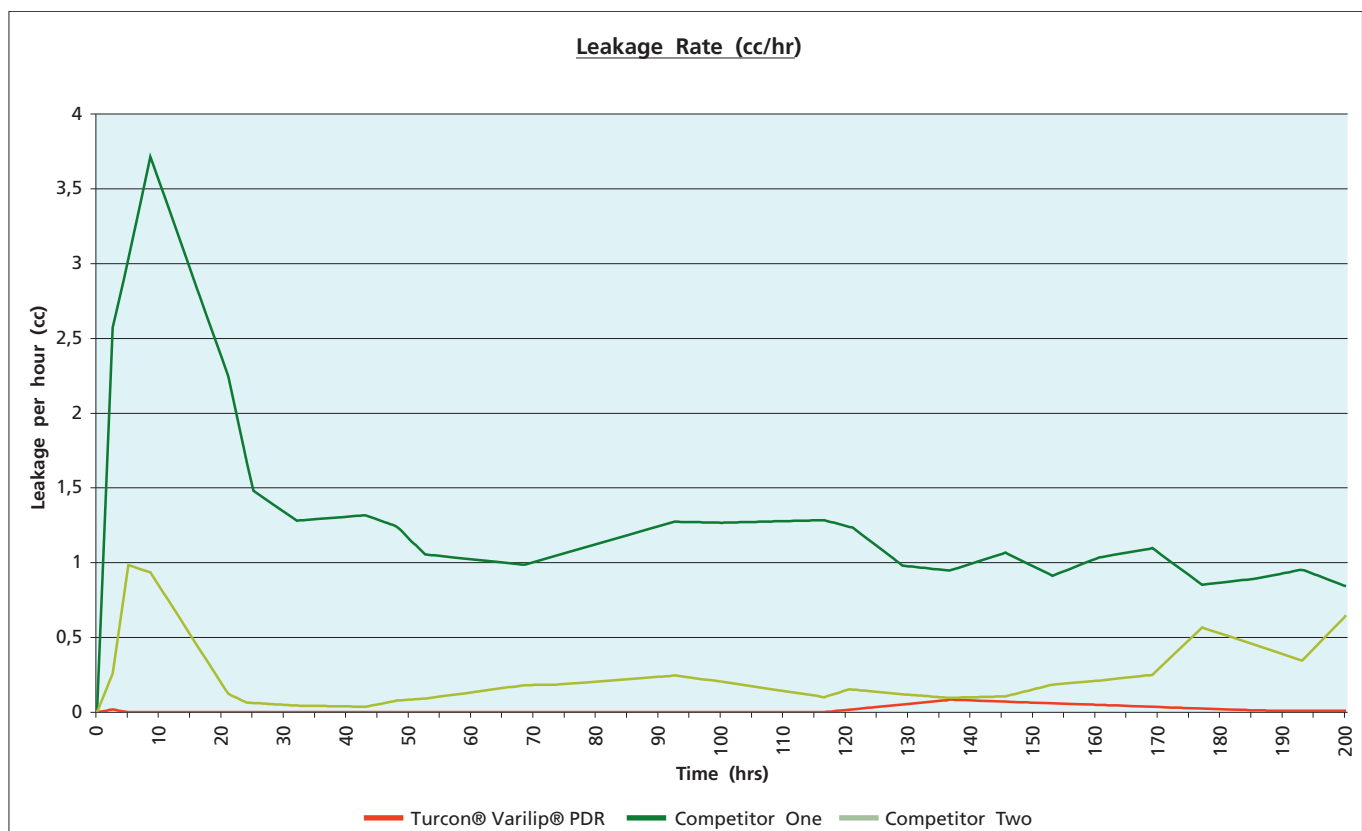

Figure 99 Leakage rate per hour monitored over 200 hour tests (average results)

Turcon® Varilip® PDR seals sometimes need a short bedding-in period before optimal sealing is provided depending on shaft topography. Once the run band is established, wear rates slow to provide good seal life.

Note: Results may vary according to application and conditions.

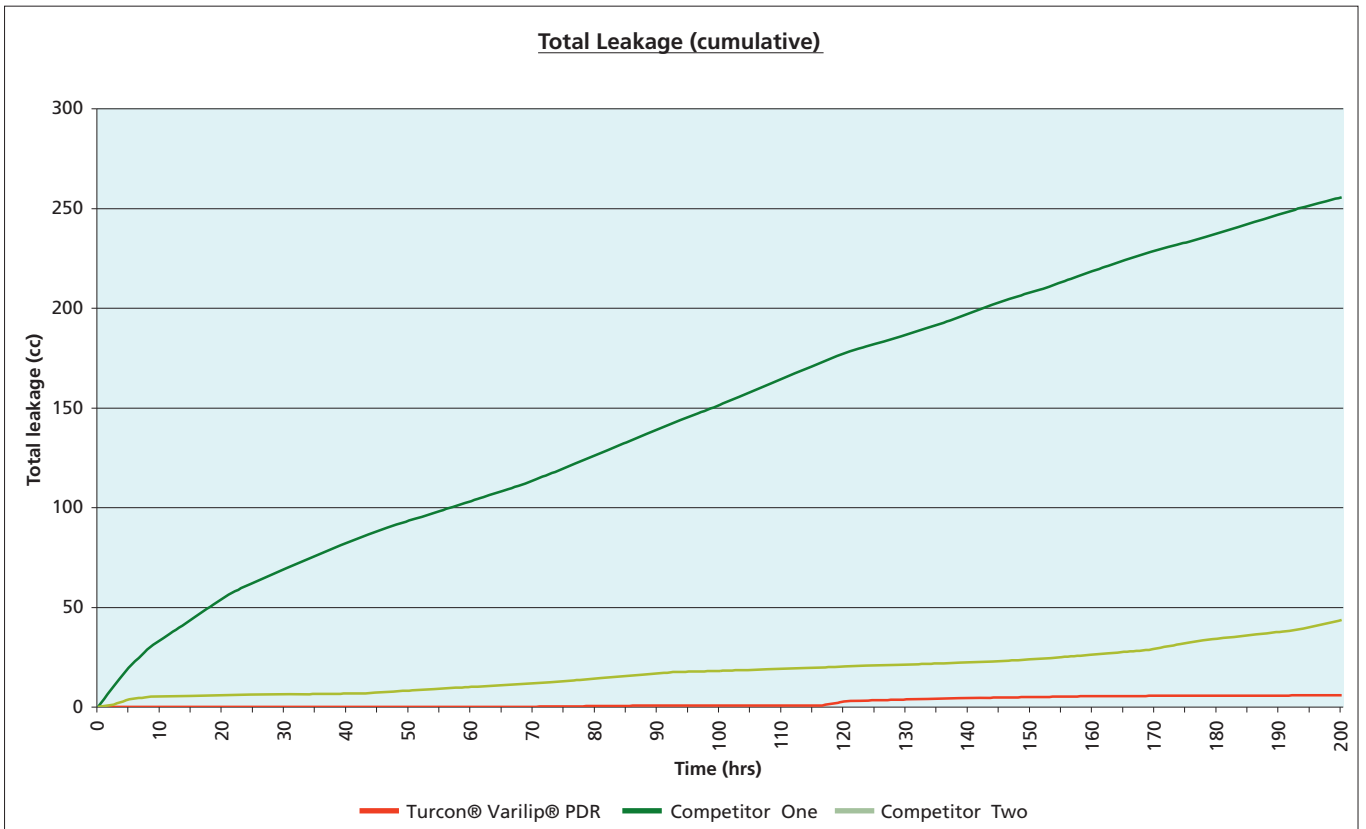

Figure 100 Total leakage (cumulative) monitored over 200 hour tests (average results)

Note: Results may vary according to application and conditions.



Heat generation considerations

All Turcon® Varilip® PDR seals are designed to contact the shaft surface during operation. The contact force between the sealing lip and the shaft will depend on the seal design used and the application details, but in all cases a temperature increase due to the presence of the seal can be expected. Where this increase is likely to be significant, consideration should be given to methods of reducing the level of generated heat. This can be achieved through increases in localized cooling, improved lubrication and efficient heat transfer and dissipation mechanisms.

Shaft wear

Turcon® Varilip® PDR seals are designed to contact the shaft surface during operation and a seal contact band will be evident in the majority of applications. With correct seal specification and operating conditions, shaft wear should be limited to a light polishing, but factors such as over pressure, contamination, eccentricity or insufficient shaft hardness can result in more significant wear.

As part of the system design, consideration should be given to the level of shaft wear permissible within a set operating period, and therefore the benefits of measures intended to reduce the rate of wear, such as shaft coatings, can be analyzed in relation to their additional cost.

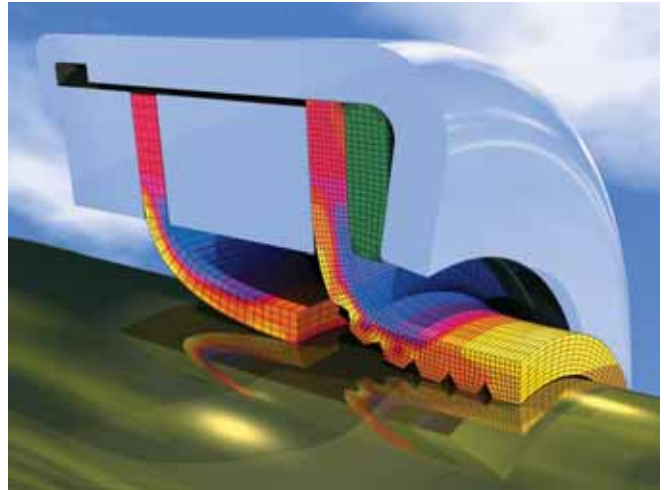



■ Design Guidelines

Housing

Turcon® Varilip® PDR seals are designed to meet global standards, including ISO 6194/1 and ISO 16589. (See tables LXX and LXXI).

Turcon® Varilip® PDR seals require an interference fit with the housing bore to provide both adequate sealing of this interface and to ensure that the seal remains in place when subjected to pressure, axial movement and induced torsion produced by the relative rotary motion of shaft to housing bore. The bore should be machined with an H8 diametric tolerance as reproduced in table LXVI below. System design should also ensure that Turcon® Varilip® PDR seals are not pushed into bores that may have been previously scored by the assembly of another component, (such as a bearing), selecting a larger seal outer diameter if necessary.

For Turcon® Varilip® PDR seals the bore should have a surface finish of 0.8µm (32 µin) Ra maximum. In cases where the housing bore is split resulting in an axial joint crossing the seal outer diameter, and in cases where meeting these surface finish requirements is not possible, it is recommended that a proprietary sealant or adhesive is used.

Alternatively a custom solution can be prepared employing a rubber covering or O-Ring for OD sealing.

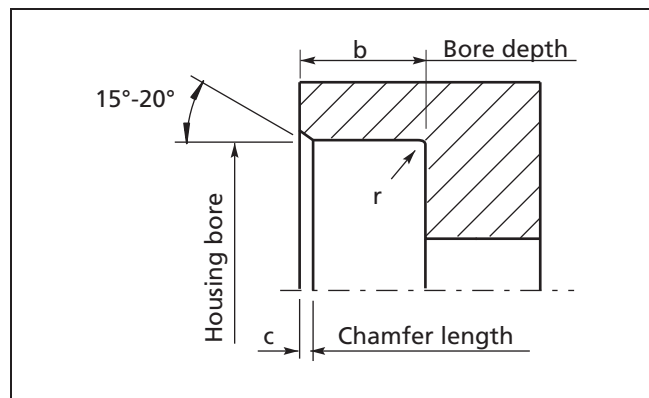

Figure 101 Housing design schematic

Table LXVII Housing Design Data

Seal width	Up to 10 [mm] / 0.394 in	Over 10 [mm] / 0.394 in
Min. bore depth (b)	b + 0.5 (0.0197 in)	b + 1.0 (0.0394 in)
Chamfer length (c)	0.70 to 1.00 (0.028 in to 0.04 in)	1.20 to 1.50 (0.047 in to 0.06 in)
Max. corner rad. (r)	0.40 (0.0157 in)	0.40 (0.0157 in)

Table LXVI Housing Installation Data Table

Bore diameter				Tolerance	
Over		To		H8 [mm]	x10 ⁻³ [in]
mm	in	mm	in		
10	0.394	18	0.787	+0.027 -0	0.0011
18	0.787	30	1.181	+0.033 -0	0.0013
30	1.181	50	1.969	+0.039 -0	0.0015
50	1.969	80	3.150	+0.046 -0	0.0018
80	3.150	120	4.724	+0.054 -0	0.0021
120	4.724	180	7.087	+0.063 -0	0.0025
180	7.087	250	9.843	+0.072 -0	0.0028
250	9.843	315	12.402	+0.081 -0	0.0032
315	12.402	400	15.748	+0.089 -0	0.0035

Shaft

This should be machined to an h11 tolerance or better, reproduced in Table LXVIII. The surface finish should be prepared by plunge grinding to avoid any machining leads that may act with the shaft rotation to facilitate leakage.

The recommended surface finish for Turcon® Varilip® PDR seals is 0.2 to 0.4 µm (8-16 µin) Ra.



Table LXVIII Shaft Installation Data

Shaft diameter				Tolerance	
Over		To		h11 [mm]	h11 [in]
mm	in	mm	in		
6	0.236	10	0.394	+0 -.900	+0 -0.0035
10	0.394	18	0.787	+0 -.110	+0 -0.0043
18	0.787	30	1.181	+0 -.130	+0 -0.0051
30	1.181	50	1.969	+0 -.160	+0 -0.0063
50	1.969	80	3.150	+0 -.190	+0 -0.0075
80	3.150	120	4.724	+0 -.220	+0 -0.0087
120	4.724	180	7.087	+0 -.250	+0 -0.0098
180	7.087	250	9.843	+0 -.290	+0 -0.0114
250	9.843	315	12.402	+0 -.320	+0 -0.0126
315	12.402	400	15.748	+0 -.360	+0 -0.0142

A shaft hardness in excess of 55 HRC is generally recommended for Turcon® Varilip® PDR, although lower values are permissible depending on the pressure, speed and sealing lip material used (refer to materials section).

Titanium shafts should be avoided unless nitrided. Shafts with good chrome, nickel or zinc plating, properly finished, are acceptable. Certain ceramic coatings can also be used, although some grades have been proven to result in an aggressive wear of the sealing lip due to their open structure. In certain applications it may not be possible to provide a shaft with the necessary hardness, surface finish and corrosion resistance. Fitting a wear sleeve onto the shaft can solve this problem by providing the local hardness and surface requirement without affecting the main shaft. If wear should occur, only the sleeve need then be replaced. The surface finish of the sleeve should be as outlined above and consideration should be given to adequate heat dissipation and effective sealing of the interface between the wear sleeve and the shaft.





■ Installation Requirements

When installing Turcon® Varilip® PDR seals, careful handling is important in order to avoid damaging the sealing lip. If the seal is installed from the back, radii or lead-in chamfers must be machined on the end of the shaft. This must also be free from burrs, sharp corners or rough machining marks, as shown in Figure 102.

When installing the seal with the lip against the shaft end, a lead-in chamfer is required whose smallest diameter is smaller than the unstressed diameter of the sealing lip as shown Figure 103. Table LXVIV shows guide values for this.

It is recommended that as shallow an angle as practical be adopted within the range given.

Table LXIX Shaft lead-in chamfer

d1 [mm]	d1 [in]	d1-d2 [mm]	d1-d2 [in]
< 10	0.4	1.5	0.06
10 - 20	0.4 - 0.8	2.0	0.08
20 - 30	0.8 - 1.2	2.5	0.10
30 - 40	1.2 - 1.6	3.0	0.12
40 - 50	1.6 - 2.0	3.5	0.14
50 - 70	2.0 - 2.8	4.0	0.16
70 - 95	2.8 - 3.7	4.5	0.18
95 - 130	3.7 - 5.1	5.5	0.22
130 - 240	5.1 - 9.4	7.0	0.28
240 - 300	9.4 - 11.8	11.0	0.43

Preferable is the use of an installation cone, as shown in Figure 16, where the seal can be fitted onto the cone before being located on the shaft to ensure correct orientation of the sealing lip.

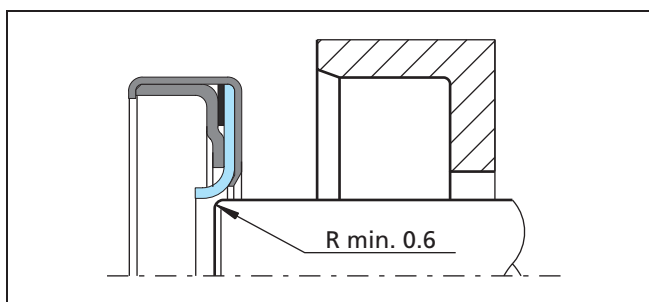

Figure 102 Installation of the sealing lip with the back to the shaft for pressurized application

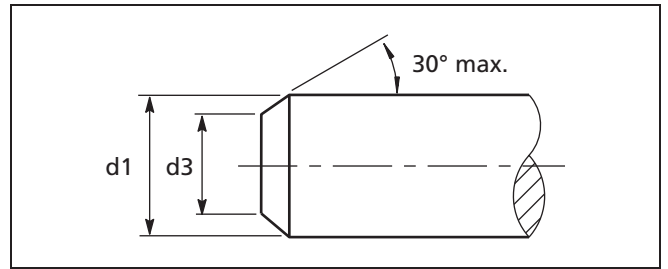

Figure 103 Shaft lead-in chamfer

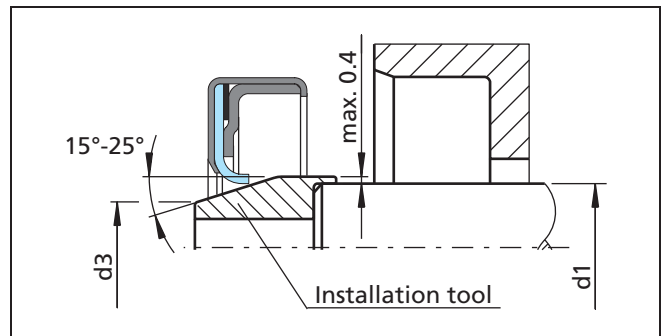

Figure 104 Fitting the sealing lip using an installation tool

Fitting should be performed in a swift movement to limit the time that the lip is formed above shaft size, therefore reducing lip recovery needed.

■ Packaging

Single and low quantities of Turcon® Varilip® PDR seals will be supplied in a blister pack with an individual transport mandrel. This mandrel will pre-form the element to above its free diameter, but below the intended shaft diameter. This assists in ease of installation, while also ensuring the element is not over-formed or damaged in transit.

Larger quantities of Turcon® Varilip® PDR seals will be supplied in a tube-and-end cap configuration.

■ Storage

Turcon® Varilip® PDR seals do not require any special storage conditions, unlike elastomer seals which must be kept away from sunlight and elevated temperatures to avoid rubber degradations.

Turcon® Varilip® PDR seals are not subject to shelf life.



■ Fitting Instructions

Investigation of premature failures has shown that a significant proportion are a result of inappropriate installation techniques. However, by observing the following guidelines, such failures can be avoided:

- Assembly sleeves and fitting tools should be regularly checked for signs of damage.
- When supplied on mandrels the seals should not be removed from the mandrel until immediately prior to fitting. Seals supplied on cardboard mandrels should be removed in the direction such that the spiral paper overlay of the mandrel is not lifted.
- Turcon® Varilip® PDR seals should be assembled on the shaft in a non-lubricated (dry) condition to avoid contamination of the hydrodynamic feature (if present).
- Care should be taken not to damage the outer diameter surface of the seal.
- Seals should be pressed squarely into the housing with the pressing-in force applied as close as possible to the outside diameter of the seal.
- If the seal contains a hydrodynamic feature on the sealing lip, ensure that it is correctly oriented in relation to the shaft's direction of rotation.
- Normal practice is to install the seal with the lip facing the medium to be sealed (the seal is reversed only when it becomes more important to exclude a medium than to retain it).
- Proprietary sealants or adhesives may be used for improved sealing of the outer diameter in critical applications or for seal retention purposes.

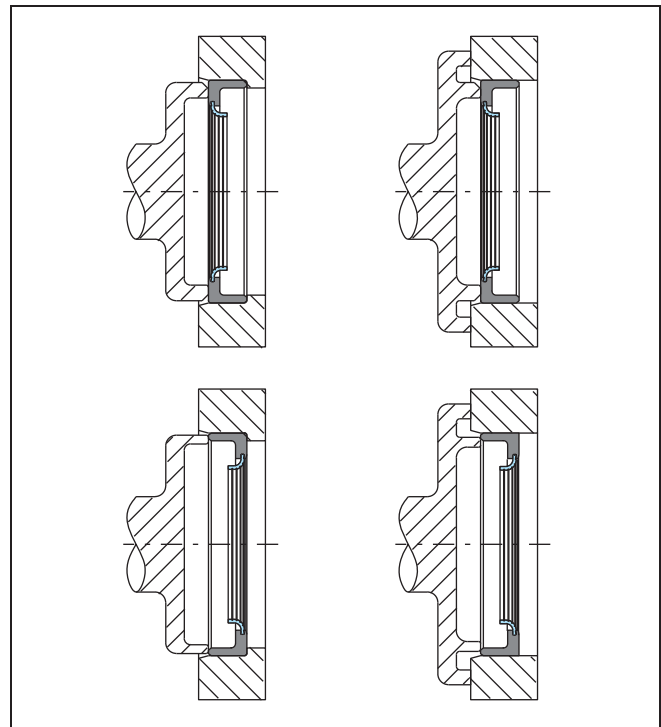

Figure 106 Assembly techniques

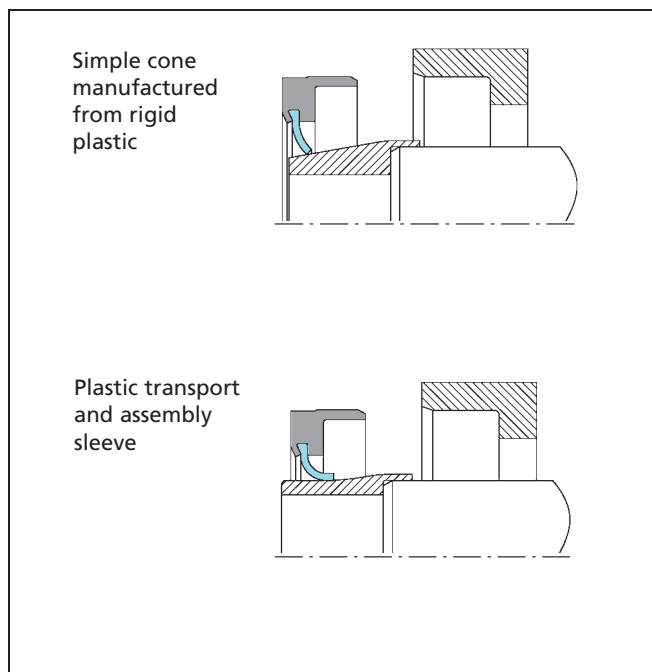

Figure 105 Assembly techniques



■ Installation Recommendations

The following diagrams show installation recommendations in respect to seal retention under pressure conditions.

Post installation recommendations:

If painting, be sure to mask the seal. Avoid getting paint on the lip or the shaft where the lip rides. Also, mask any vents or drain holes so they will not become clogged. Be sure to remove masks before operating unit.

If paint is to be baked, or the mechanism is otherwise subjected to heat, seals should not be heated to temperatures higher than their materials can tolerate.

In cleaning or testing, do not subject seals to any fluids or pressures other than those for which the seals have been specified.

Extraction features such as tapped holes, internal threads or simple grooves can be included in custom PDR designs.

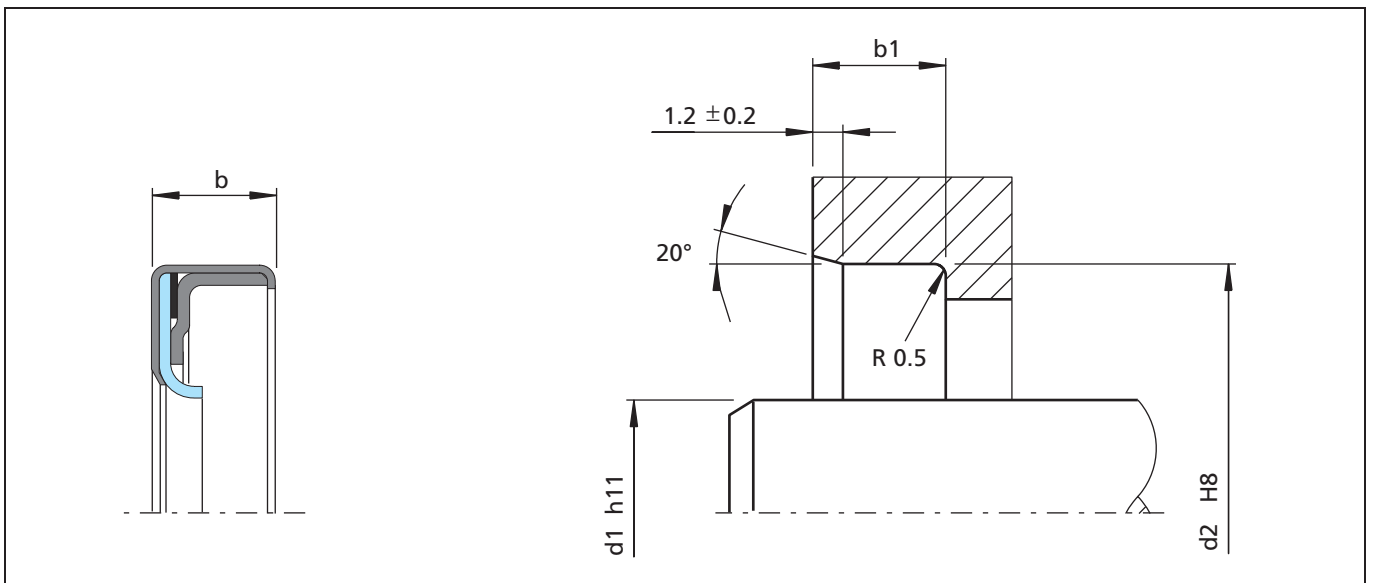

Figure 107 Installation drawing for pressure up to 0.5 MPa (73 psi)

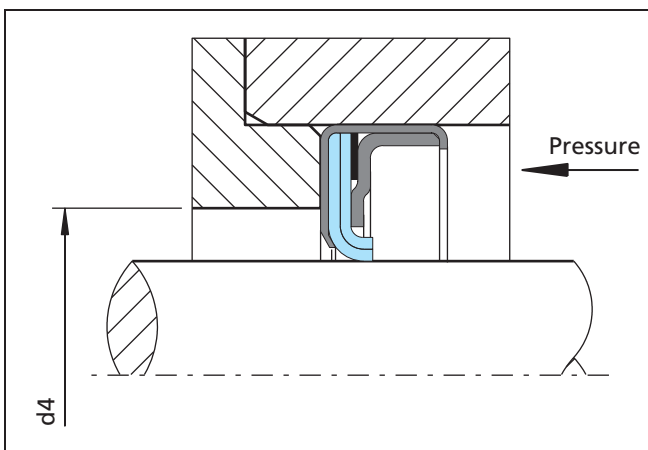

Figure 108 Installation for pressure from 0.5 MPa (73 psi) up to 1 MPa (145 psi)

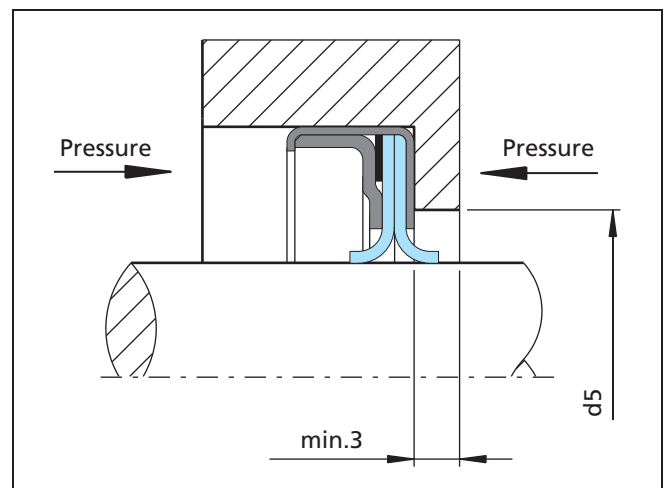

Figure 109 Installation type for fluid separation at pressures up to 1.0 MPa (145 psi)



■ Turcon® Varilip® PDR Size Ranges

Table LXX Turcon® Varilip® PDR Metric Size Range

Sizes				TSS Part No.	Sizes		
d1 [mm]	d2 [mm]	b [mm] exc. TJB	b [mm] TJB		b1 min. [mm]	d4 max. [mm]	d5 min. [mm]
6	16	7	10	TJ_1_0060	7.3 / 10.3	10	9.6
6	22	7	10	TJ_2_0060	7.3 / 10.3	10	9.6
7	22	7	10	TJ_1_0070	7.3 / 10.3	11	10.6
8	22	7	10	TJ_1_0080	7.3 / 10.3	12	11.6
8	24	7	10	TJ_2_0080	7.3 / 10.3	12	11.6
9	22	7	10	TJ_1_0090	7.3 / 10.3	13	12.6
9	24	7	10	TJ_2_0090	7.3 / 10.3	13	12.6
9	26	7	10	TJ_3_0090	7.3 / 10.3	13	12.6
10	22	7	10	TJ_1_0100	7.3 / 10.3	14	13.6
10	24	7	10	TJ_2_0100	7.3 / 10.3	14	13.6
10	25	7	10	TJ_3_0100	7.3 / 10.3	14	13.6
10	26	7	10	TJ_4_0100	7.3 / 10.3	14	13.6
11	22	7	10	TJ_1_0110	7.3 / 10.3	15	14.6
11	26	7	10	TJ_2_0110	7.3 / 10.3	15	14.6
12	22	7	10	TJ_1_0120	7.3 / 10.3	16	15.6
12	24	7	10	TJ_2_0120	7.3 / 10.3	16	15.6
12	25	7	10	TJ_3_0120	7.3 / 10.3	16	15.6
12	28	7	10	TJ_4_0120	7.3 / 10.3	16	15.6
12	30	7	10	TJ_5_0120	7.3 / 10.3	16	15.6
14	24	7	10	TJ_1_0140	7.3 / 10.3	18	17.6
14	28	7	10	TJ_2_0140	7.3 / 10.3	18	17.6
14	30	7	10	TJ_3_0140	7.3 / 10.3	18	17.6
14	35	7	10	TJ_4_0140	7.3 / 10.3	18	17.6
15	26	7	10	TJ_1_0150	7.3 / 10.3	19	18.6
15	30	7	10	TJ_2_0150	7.3 / 10.3	19	18.6
15	32	7	10	TJ_3_0150	7.3 / 10.3	19	18.6
15	35	7	10	TJ_4_0150	7.3 / 10.3	19	18.6
16	28	7	10	TJ_1_0160	7.3 / 10.3	20	19.6
16	30	7	10	TJ_2_0160	7.3 / 10.3	20	19.6
16	32	7	10	TJ_3_0160	7.3 / 10.3	20	19.6
16	35	7	10	TJ_4_0160	7.3 / 10.3	20	19.6
17	28	7	10	TJ_1_0170	7.3 / 10.3	21	20.6
17	30	7	10	TJ_2_0170	7.3 / 10.3	21	20.6
17	32	7	10	TJ_3_0170	7.3 / 10.3	21	20.6
17	35	7	10	TJ_4_0170	7.3 / 10.3	21	20.6
17	40	7	10	TJ_5_0170	7.3 / 10.3	21	20.6
18	30	7	10	TJ_1_0180	7.3 / 10.3	22	21.6
18	32	7	10	TJ_2_0180	7.3 / 10.3	22	21.6
18	35	7	10	TJ_3_0180	7.3 / 10.3	22	21.6
18	40	7	10	TJ_4_0180	7.3 / 10.3	22	21.6
20	30	7	10	TJ_1_0200	7.3 / 10.3	24	23.6
20	32	7	10	TJ_2_0200	7.3 / 10.3	24	23.6
20	35	7	10	TJ_3_0200	7.3 / 10.3	24	23.6
20	40	7	10	TJ_4_0200	7.3 / 10.3	24	23.6
20	47	7	10	TJ_5_0200	7.3 / 10.3	24	23.6

Sealing lips may, in some cases, protrude beyond the edge of the seal body.

Sizes printed in **bold** are preferred. Sizes not stated on these tables are available on request (note this will include a tooling charge).



Sizes				TSS Part No.	Sizes		
d1 [mm]	d2 [mm]	b [mm] exc. TJB	b [mm] TJB		b1 min. [mm]	d4 max. [mm]	d5 min. [mm]
22	32	7	10	TJ_1_0220	7.3 / 10.3	26	25.6
22	35	7	10	TJ_2_0220	7.3 / 10.3	26	25.6
22	40	7	10	TJ_3_0220	7.3 / 10.3	26	25.6
22	47	7	10	TJ_4_0220	7.3 / 10.3	26	25.6
24	35	7	10	TJ_1_0240	7.3 / 10.3	28	27.6
24	37	7	10	TJ_2_0240	7.3 / 10.3	28	27.6
24	40	7	10	TJ_3_0240	7.3 / 10.3	28	27.6
24	47	7	10	TJ_4_0240	7.3 / 10.3	28	27.6
25	35	7	10	TJ_1_0250	7.3 / 10.3	29	28.6
25	40	7	10	TJ_2_0250	7.3 / 10.3	29	28.6
25	42	7	10	TJ_3_0250	7.3 / 10.3	29	28.6
25	47	7	10	TJ_4_0250	7.3 / 10.3	29	28.6
25	52	7	10	TJ_5_0250	7.3 / 10.3	29	28.6
26	37	7	10	TJ_1_0260	7.3 / 10.3	30	29.6
26	42	7	10	TJ_2_0260	7.3 / 10.3	30	29.6
26	47	7	10	TJ_3_0260	7.3 / 10.3	30	29.6
28	40	7	10	TJ_1_0280	7.3 / 10.3	32	31.6
28	47	7	10	TJ_2_0280	7.3 / 10.3	32	31.6
28	52	7	10	TJ_3_0280	7.3 / 10.3	32	31.6
30	40	7	10	TJ_1_0300	7.3 / 10.3	34	33.6
30	42	7	10	TJ_2_0300	7.3 / 10.3	34	33.6
30	47	7	10	TJ_3_0300	7.3 / 10.3	34	33.6
30	52	7	10	TJ_4_0300	7.3 / 10.3	34	33.6
30	62	7	10	TJ_5_0300	7.3 / 10.3	34	33.6
32	45	7	10	TJ_1_0320	7.3 / 10.3	36	35.6
32	45	8	10	TJ_2_0320	8.3 / 10.3	36	35.6
32	47	7	10	TJ_3_0320	7.3 / 10.3	36	35.6
32	47	8	10	TJ_4_0320	8.3 / 10.3	36	35.6
32	52	7	10	TJ_5_0320	7.3 / 10.3	36	35.6
32	52	8	10	TJ_6_0320	8.3 / 10.3	36	35.6
35	47	7	10	TJ_1_0350	7.3 / 10.3	39	38.6
35	50	7	10	TJ_2_0350	7.3 / 10.3	39	38.6
35	50	8	10	TJ_3_0350	8.3 / 10.3	39	38.6
35	52	7	10	TJ_4_0350	7.3 / 10.3	39	38.6
35	52	8	10	TJ_5_0350	8.3 / 10.3	39	38.6
35	55	8	10	TJ_6_0350	8.3 / 10.3	39	38.6
35	62	7	10	TJ_7_0350	7.3 / 10.3	39	38.6
36	47	7	10	TJ_1_0360	7.3 / 10.3	40	39.6
36	50	7	10	TJ_2_0360	7.3 / 10.3	40	39.6
36	52	7	10	TJ_3_0360	7.3 / 10.3	40	39.6
36	62	7	10	TJ_4_0360	7.3 / 10.3	40	39.6
38	52	7	10	TJ_1_0380	7.3 / 10.3	42	41.6
38	55	7	10	TJ_2_0380	7.3 / 10.3	42	41.6
38	55	8	10	TJ_3_0380	8.3 / 10.3	42	41.6
38	58	8	10	TJ_4_0380	8.3 / 10.3	42	41.6
38	62	7	10	TJ_5_0380	7.3 / 10.3	42	41.6
38	62	8	10	TJ_6_0380	8.3 / 10.3	42	41.6
40	52	7	10	TJ_1_0400	7.3 / 10.3	44	43.6
40	55	7	10	TJ_2_0400	7.3 / 10.3	44	43.6
40	55	8	10	TJ_3_0400	8.3 / 10.3	44	43.6
40	62	7	10	TJ_4_0400	7.3 / 10.3	44	43.6

Sealing lips may, in some cases, protrude beyond the edge of the seal body.

Sizes printed in **bold** are preferred. Sizes not stated on these tables are available on request (note this will include a tooling charge).



Turcon® Varilip® PDR

Sizes				TSS Part No.	Sizes		
d1 [mm]	d2 [mm]	b [mm] exc. TJB	b [mm] TJB		b1 min. [mm]	d4 max. [mm]	d5 min. [mm]
40	62	8	10	TJ_5_0400	8.3 / 10.3	44	43.6
40	72	7	10	TJ_6_0400	7.3 / 10.3	44	43.6
42	55	8	10	TJ_1_0420	8.3 / 10.3	46	45.6
42	62	8	10	TJ_2_0420	8.3 / 10.3	46	45.6
42	72	8	10	TJ_3_0420	8.3 / 10.3	46	45.6
45	60	8	10	TJ_1_0450	8.3 / 10.3	49	48.6
45	62	8	10	TJ_2_0450	8.3 / 10.3	49	48.6
45	65	8	10	TJ_3_0450	8.3 / 10.3	49	48.6
45	72	8	10	TJ_4_0450	8.3 / 10.3	49	48.6
48	62	8	10	TJ_1_0480	8.3 / 10.3	52	51.6
48	72	8	10	TJ_2_0480	8.3 / 10.3	52	51.6
50	65	8	10	TJ_1_0500	8.3 / 10.3	54	53.6
50	68	8	10	TJ_2_0500	8.3 / 10.3	54	53.6
50	72	8	10	TJ_3_0500	8.3 / 10.3	54	53.6
50	80	8	10	TJ_4_0500	8.3 / 10.3	54	53.6
52	68	8	10	TJ_1_0520	8.3 / 10.3	56	55.6
52	72	8	10	TJ_2_0520	8.3 / 10.3	56	55.6
55	70	8	10	TJ_1_0550	8.3 / 10.3	59	58.6
55	72	8	10	TJ_2_0550	8.3 / 10.3	59	58.6
55	80	8	10	TJ_3_0550	8.3 / 10.3	59	58.6
55	85	8	10	TJ_4_0550	8.3 / 10.3	59	58.6
56	70	8	10	TJ_1_0560	8.3 / 10.3	60	59.6
56	72	8	10	TJ_2_0560	8.3 / 10.3	60	59.6
56	80	8	10	TJ_3_0560	8.3 / 10.3	60	59.6
56	85	8	10	TJ_4_0560	8.3 / 10.3	60	59.6
58	72	8	10	TJ_1_0580	8.3 / 10.3	62	61.6
58	80	8	10	TJ_2_0580	8.3 / 10.3	62	61.6
60	75	8	10	TJ_1_0600	8.3 / 10.3	64	63.6
60	80	8	10	TJ_2_0600	8.3 / 10.3	64	63.6
60	85	8	10	TJ_3_0600	8.3 / 10.3	64	63.6
60	90	8	10	TJ_4_0600	8.3 / 10.3	64	63.6
62	85	10	10	TJ_1_0620	10.3	68	66.4
62	90	10	10	TJ_2_0620	10.3	68	66.4
63	85	10	10	TJ_1_0630	10.3	69	67.4
63	90	10	10	TJ_2_0630	10.3	69	67.4
65	85	10	10	TJ_1_0650	10.3	71	69.4
65	90	10	10	TJ_2_0650	10.3	71	69.4
65	100	10	10	TJ_3_0650	10.3	71	69.4
68	90	10	10	TJ_1_0680	10.3	74	72.4
68	100	10	10	TJ_2_0680	10.3	74	72.4
70	90	10	10	TJ_1_0700	10.3	76	74.4
70	95	10	10	TJ_2_0700	10.3	76	74.4
70	100	10	10	TJ_3_0700	10.3	76	74.4
72	95	10	10	TJ_1_0720	10.3	78	76.4
72	100	10	10	TJ_2_0720	10.3	78	76.4
75	95	10	10	TJ_1_0750	10.3	81	79.4
75	100	10	10	TJ_2_0750	10.3	81	79.4
78	100	10	10	TJ_1_0780	10.3	84	82.4
80	100	10	10	TJ_1_0800	10.3	86	84.4
80	110	10	10	TJ_2_0800	10.3	86	84.4
85	110	12	12	TJ_1_0850	12.4	91	89.4

Sealing lips may, in some cases, protrude beyond the edge of the seal body.

Sizes printed in **bold** are preferred. Sizes not stated on these tables are available on request (note this will include a tooling charge).



Sizes				TSS Part No.	Sizes		
d1 [mm]	d2 [mm]	b [mm] exc. TJB	b [mm] TJB		b1 min. [mm]	d4 max. [mm]	d5 min. [mm]
85	120	12	12	TJ_2_0850	12.4	91	89.4
90	110	12	12	TJ_1_0900	12.4	96	94.4
90	120	12	12	TJ_2_0900	12.4	96	94.4
95	120	12	12	TJ_1_0950	12.4	101	99.4
95	125	12	12	TJ_2_0950	12.4	101	99.4
100	120	12	12	TJ_1_1000	12.4	106	104.4
100	125	12	12	TJ_2_1000	12.4	106	104.4
100	130	12	12	TJ_3_1000	12.4	106	104.4
105	130	12	12	TJ_1_1050	12.4	111	109.4
105	140	12	12	TJ_2_1050	12.4	111	109.4
110	130	12	12	TJ_1_1100	12.4	116	114.4
110	140	12	12	TJ_2_1100	12.4	116	114.4
115	140	12	12	TJ_1_1150	12.4	121	119.4
115	150	12	12	TJ_2_1150	12.4	121	119.4
120	150	12	12	TJ_1_1200	12.4	126	124.4
120	160	12	12	TJ_2_1200	12.4	126	124.4
125	150	12	12	TJ_1_1250	12.4	131	129.4
125	160	12	12	TJ_2_1250	12.4	131	129.4
130	160	12	12	TJ_1_1300	12.4	136	134.4
130	170	12	12	TJ_2_1300	12.4	136	134.4
135	170	12	12	TJ_1_1350	12.4	141	139.4
140	170	15	15	TJ_1_1400	15.4	148	147.0
145	175	15	15	TJ_1_1450	15.4	153	152.0
150	180	15	15	TJ_1_1500	15.4	158	157.0
160	190	15	15	TJ_1_1600	15.4	168	167.0
170	200	15	15	TJ_1_1700	15.4	178	177.0

Sealing lips may, in some cases, protrude beyond the edge of the seal body.
 Sizes printed in **bold** are preferred. Sizes not stated on these tables are available on request (note this will include a tooling charge).



Table LXXI Turcon® Varilip® PDR Inch Size Range

Sizes				TSS Part No.	Sizes		
d1 [inch]	d2 [inch]	b [inch]	b [inch] TJB		b1 min. [inch]	d4 max. [inch]	d5 min. [inch]
0.438 0.438 0.438	0.938 1.063 1.188	0.276 0.276 0.276	0.393 0.393 0.393	TJ_E_D407 TJ_F_D507 TJ_G_D607	0.288 / 0.405 0.288 / 0.405 0.288 / 0.405	0.595 0.595 0.595	0.580 0.580 0.580
0.438 0.438 0.500	1.313 1.438 1.000	0.276 0.276 0.276	0.393 0.393 0.393	TJ_H_D707 TJ_J_D807 TJ_E_D408	0.288 / 0.405 0.288 / 0.405 0.288 / 0.405	0.595 0.595 0.657	0.580 0.580 0.642
0.500 0.500 0.500	1.125 1.250 1.375	0.276 0.276 0.276	0.393 0.393 0.393	TJ_F_D508 TJ_G_D608 TJ_H_D708	0.288 / 0.405 0.288 / 0.405 0.288 / 0.405	0.657 0.657 0.657	0.642 0.642 0.642
0.500 0.563 0.563	1.500 1.063 1.188	0.276 0.276 0.276	0.393 0.393 0.393	TJ_J_D808 TJ_E_D409 TJ_F_D509	0.288 / 0.405 0.288 / 0.405 0.288 / 0.405	0.657 0.720 0.720	0.642 0.705 0.705
0.563 0.563 0.563	1.313 1.438 1.563	0.276 0.276 0.276	0.393 0.393 0.393	TJ_G_D609 TJ_H_D709 TJ_J_D809	0.288 / 0.405 0.288 / 0.405 0.288 / 0.405	0.720 0.720 0.720	0.705 0.705 0.705
0.625 0.625 0.625	1.125 1.250 1.375	0.276 0.276 0.276	0.393 0.393 0.393	TJ_E_D410 TJ_F_D510 TJ_G_D610	0.288 / 0.405 0.288 / 0.405 0.288 / 0.405	0.782 0.782 0.782	0.767 0.767 0.767
0.625 0.625 0.688	1.500 1.625 1.188	0.276 0.276 0.276	0.393 0.393 0.393	TJ_H_D710 TJ_J_D810 TJ_E_D411	0.288 / 0.405 0.288 / 0.405 0.288 / 0.405	0.782 0.782 0.845	0.767 0.767 0.830
0.688 0.688 0.688	1.313 1.438 1.563	0.276 0.276 0.276	0.393 0.393 0.393	TJ_F_D511 TJ_G_D611 TJ_H_D711	0.288 / 0.405 0.288 / 0.405 0.288 / 0.405	0.845 0.845 0.845	0.830 0.830 0.830
0.688 0.750 0.750	1.688 1.250 1.375	0.276 0.276 0.276	0.393 0.393 0.393	TJ_J_D811 TJ_E_D412 TJ_F_D512	0.288 / 0.405 0.288 / 0.405 0.288 / 0.405	0.845 0.907 0.907	0.830 0.892 0.892
0.750 0.750 0.750	1.500 1.625 1.750	0.276 0.276 0.276	0.393 0.393 0.393	TJ_G_D612 TJ_H_D712 TJ_J_D812	0.288 / 0.405 0.288 / 0.405 0.288 / 0.405	0.907 0.907 0.907	0.892 0.892 0.892
0.813 0.813 0.813	1.313 1.438 1.563	0.276 0.276 0.276	0.393 0.393 0.393	TJ_E_D413 TJ_F_D513 TJ_G_D613	0.288 / 0.405 0.288 / 0.405 0.288 / 0.405	0.970 0.970 0.970	0.955 0.955 0.955
0.813 0.813 0.875	1.688 1.813 1.375	0.276 0.276 0.276	0.393 0.393 0.393	TJ_H_D713 TJ_J_D813 TJ_E_D414	0.288 / 0.405 0.288 / 0.405 0.288 / 0.405	0.970 0.970 1.032	0.955 0.955 1.017
0.875 0.875 0.875	1.500 1.625 1.750	0.276 0.276 0.276	0.393 0.393 0.393	TJ_F_D514 TJ_G_D614 TJ_H_D714	0.288 / 0.405 0.288 / 0.405 0.288 / 0.405	1.032 1.032 1.032	1.017 1.017 1.017
0.875 0.938 0.938	1.875 1.438 1.563	0.276 0.276 0.276	0.393 0.393 0.393	TJ_J_D814 TJ_E_D415 TJ_F_D515	0.288 / 0.405 0.288 / 0.405 0.288 / 0.405	1.032 1.095 1.095	1.017 1.080 1.080
0.938 0.938 0.938	1.688 1.813 1.938	0.276 0.276 0.276	0.393 0.393 0.393	TJ_G_D615 TJ_H_D715 TJ_J_D815	0.288 / 0.405 0.288 / 0.405 0.288 / 0.405	1.095 1.095 1.095	1.080 1.080 1.080
1.000 1.000 1.000	1.500 1.625 1.750	0.276 0.276 0.276	0.393 0.393 0.393	TJ_E_D416 TJ_F_D516 TJ_G_D616	0.288 / 0.405 0.288 / 0.405 0.288 / 0.405	1.157 1.157 1.157	1.142 1.142 1.142

Sealing lips may, in some cases, protrude beyond the edge of the seal body.

Sizes printed in **bold** are preferred. Sizes not stated on these tables are available on request (note this will include a tooling charge).



Sizes				TSS Part No.	Sizes		
d1 [inch]	d2 [inch]	b [inch]	b [inch] TJB		b1 min. [inch]	d4 max. [inch]	d5 min. [inch]
1.000	1.875	0.276	0.393	TJ_H_D716	0.288 / 0.405	1.157	1.142
1.000	2.000	0.276	0.393	TJ_J_D816	0.288 / 0.405	1.157	1.142
1.125	1.625	0.276	0.393	TJ_E_D418	0.288 / 0.405	1.282	1.267
1.125	1.750	0.276	0.393	TJ_F_D518	0.288 / 0.405	1.282	1.267
1.125	1.875	0.276	0.393	TJ_G_D618	0.288 / 0.405	1.282	1.267
1.125	2.000	0.276	0.393	TJ_H_D718	0.288 / 0.405	1.282	1.267
1.125	2.125	0.276	0.393	TJ_J_D818	0.288 / 0.405	1.282	1.267
1.250	1.750	0.276	0.393	TJ_E_D420	0.288 / 0.405	1.407	1.392
1.250	1.875	0.276	0.393	TJ_F_D520	0.288 / 0.405	1.407	1.392
1.250	2.000	0.276	0.393	TJ_G_D620	0.288 / 0.405	1.407	1.392
1.250	2.125	0.276	0.393	TJ_H_D720	0.288 / 0.405	1.407	1.392
1.250	2.250	0.276	0.393	TJ_J_D820	0.288 / 0.405	1.407	1.392
1.375	1.875	0.276	0.393	TJ_E_D422	0.288 / 0.405	1.532	1.517
1.375	2.000	0.276	0.393	TJ_F_D522	0.288 / 0.405	1.532	1.517
1.375	2.125	0.276	0.393	TJ_G_D622	0.288 / 0.405	1.532	1.517
1.375	2.250	0.276	0.393	TJ_H_D722	0.288 / 0.405	1.532	1.517
1.375	2.375	0.276	0.393	TJ_J_D822	0.288 / 0.405	1.532	1.517
1.500	2.000	0.276	0.393	TJ_E_D424	0.288 / 0.405	1.657	1.642
1.500	2.125	0.276	0.393	TJ_F_D524	0.288 / 0.405	1.657	1.642
1.500	2.250	0.276	0.393	TJ_G_D624	0.288 / 0.405	1.657	1.642
1.500	2.375	0.276	0.393	TJ_H_D724	0.288 / 0.405	1.657	1.642
1.500	2.500	0.276	0.393	TJ_J_D824	0.288 / 0.405	1.657	1.642
1.625	2.125	0.276	0.393	TJ_E_D426	0.288 / 0.405	1.782	1.767
1.625	2.250	0.276	0.393	TJ_F_D526	0.288 / 0.405	1.782	1.767
1.625	2.375	0.276	0.393	TJ_G_D626	0.288 / 0.405	1.782	1.767
1.625	2.500	0.276	0.393	TJ_H_D726	0.288 / 0.405	1.782	1.767
1.625	2.625	0.276	0.393	TJ_J_D826	0.288 / 0.405	1.782	1.767
1.750	2.250	0.276	0.393	TJ_E_D428	0.288 / 0.405	1.907	1.892
1.750	2.375	0.276	0.393	TJ_F_D528	0.288 / 0.405	1.907	1.892
1.750	2.500	0.276	0.393	TJ_G_D628	0.288 / 0.405	1.907	1.892
1.750	2.625	0.276	0.393	TJ_H_D728	0.288 / 0.405	1.907	1.892
1.750	2.750	0.276	0.393	TJ_J_D828	0.288 / 0.405	1.907	1.892
1.875	2.375	0.276	0.393	TJ_E_D430	0.288 / 0.405	2.032	2.017
1.875	2.500	0.276	0.393	TJ_F_D530	0.288 / 0.405	2.032	2.017
1.875	2.625	0.276	0.393	TJ_G_D630	0.288 / 0.405	2.032	2.017
1.875	2.750	0.276	0.393	TJ_H_D730	0.288 / 0.405	2.032	2.017
1.875	2.875	0.276	0.393	TJ_J_D830	0.288 / 0.405	2.032	2.017
2.000	2.500	0.276	0.393	TJ_E_D432	0.288 / 0.405	2.157	2.142
2.000	2.625	0.276	0.393	TJ_F_D532	0.288 / 0.405	2.157	2.142
2.000	2.750	0.276	0.393	TJ_G_D632	0.288 / 0.405	2.157	2.142
2.000	2.875	0.276	0.393	TJ_H_D732	0.288 / 0.405	2.157	2.142
2.000	3.000	0.276	0.393	TJ_J_D832	0.288 / 0.405	2.157	2.142
2.125	2.625	0.276	0.393	TJ_E_D434	0.288 / 0.405	2.282	2.267
2.125	2.750	0.276	0.393	TJ_F_D534	0.288 / 0.405	2.282	2.267
2.125	2.875	0.276	0.393	TJ_G_D634	0.288 / 0.405	2.282	2.267
2.125	3.000	0.276	0.393	TJ_H_D734	0.288 / 0.405	2.282	2.267
2.125	3.125	0.276	0.393	TJ_J_D834	0.288 / 0.405	2.282	2.267
2.250	2.750	0.276	0.393	TJ_E_D436	0.288 / 0.405	2.407	2.392
2.250	2.875	0.276	0.393	TJ_F_D536	0.288 / 0.405	2.407	2.392
2.250	3.000	0.276	0.393	TJ_G_D636	0.288 / 0.405	2.407	2.392
2.250	3.125	0.276	0.393	TJ_H_D736	0.288 / 0.405	2.407	2.392

Sealing lips may, in some cases, protrude beyond the edge of the seal body.

Sizes printed in **bold** are preferred. Sizes not stated on these tables are available on request (note this will include a tooling charge).



Sizes				TSS Part No.	Sizes		
d1 [inch]	d2 [inch]	b [inch]	b [inch] TJB		b1 min. [inch]	d4 max. [inch]	d5 min. [inch]
2.250 2.375 2.375	3.250 2.875 3.000	0.276 0.276 0.276	0.393 0.393 0.393	TJ_J_D836 TJ_E_D438 TJ_F_D538	0.288 / 0.405 0.288 / 0.405 0.288 / 0.405	2.407 2.532 2.532	2.392 2.517 2.517
2.375 2.375 2.375	3.125 3.250 3.375	0.276 0.276 0.276	0.393 0.393 0.393	TJ_G_D638 TJ_H_D738 TJ_J_D838	0.288 / 0.405 0.288 / 0.405 0.288 / 0.405	2.532 2.532 2.532	2.517 2.517 2.517
2.500 2.500 2.500	3.000 3.125 3.250	0.315 0.315 0.315	0.393 0.393 0.393	TJ_E_D440 TJ_F_D540 TJ_G_D640	0.327 / 0.405 0.327 / 0.405 0.327 / 0.405	2.657 2.657 2.657	2.642 2.642 2.642
2.500 2.500 2.625	3.375 3.500 3.125	0.315 0.315 0.315	0.393 0.393 0.393	TJ_H_D740 TJ_J_D840 TJ_E_D442	0.327 / 0.405 0.327 / 0.405 0.327 / 0.405	2.657 2.657 2.861	2.642 2.642 2.798
2.625 2.625 2.625	3.250 3.375 3.500	0.315 0.315 0.315	0.393 0.393 0.393	TJ_F_D542 TJ_G_D642 TJ_H_D742	0.327 / 0.405 0.327 / 0.405 0.327 / 0.405	2.861 2.861 2.861	2.798 2.798 2.798
2.625 2.750 2.750	3.625 3.250 3.375	0.315 0.315 0.315	0.393 0.393 0.393	TJ_J_D842 TJ_E_D444 TJ_F_D544	0.327 / 0.405 0.327 / 0.405 0.327 / 0.405	2.861 2.986 2.986	2.798 2.923 2.923
2.750 2.750 2.750	3.500 3.625 3.750	0.315 0.315 0.315	0.393 0.393 0.393	TJ_G_D644 TJ_H_D744 TJ_J_D844	0.327 / 0.405 0.327 / 0.405 0.327 / 0.405	2.986 2.986 2.986	2.923 2.923 2.923
2.875 2.875 2.875	3.375 3.500 3.625	0.315 0.315 0.315	0.393 0.393 0.393	TJ_E_D446 TJ_F_D546 TJ_G_D646	0.327 / 0.405 0.327 / 0.405 0.327 / 0.405	3.111 3.111 3.111	3.048 3.048 3.048
2.875 2.875 3.000	3.750 3.875 3.500	0.315 0.315 0.315	0.393 0.393 0.393	TJ_H_D746 TJ_J_D846 TJ_E_D448	0.327 / 0.405 0.327 / 0.405 0.327 / 0.405	3.111 3.111 3.236	3.048 3.048 3.173
3.000 3.000 3.000	3.625 3.750 3.875	0.315 0.315 0.315	0.393 0.393 0.393	TJ_F_D548 TJ_G_D648 TJ_H_D748	0.327 / 0.405 0.327 / 0.405 0.327 / 0.405	3.236 3.236 3.236	3.173 3.173 3.173
3.000 3.125 3.125	4.000 3.625 3.750	0.315 0.315 0.315	0.393 0.393 0.393	TJ_J_D848 TJ_E_D450 TJ_F_D550	0.327 / 0.405 0.327 / 0.405 0.327 / 0.405	3.236 3.361 3.361	3.173 3.298 3.298
3.125 3.125 3.125	3.875 4.000 4.125	0.315 0.315 0.315	0.393 0.393 0.393	TJ_G_D650 TJ_H_D750 TJ_J_D850	0.327 / 0.405 0.327 / 0.405 0.327 / 0.405	3.361 3.361 3.361	3.298 3.298 3.298
3.250 3.250 3.250	3.875 4.000 4.125	0.315 0.315 0.315	0.393 0.393 0.393	TJ_F_D552 TJ_G_D652 TJ_H_D752	0.327 / 0.405 0.327 / 0.405 0.327 / 0.405	3.486 3.486 3.486	3.423 3.423 3.423
3.250 3.375 3.375	4.250 4.000 4.125	0.315 0.472 0.472	0.393 0.472 0.472	TJ_J_D852 TJ_F_D554 TJ_G_D654	0.327 / 0.405 0.484 0.484	3.486 3.611 3.611	3.423 3.548 3.548
3.375 3.375 3.500	4.250 4.375 4.125	0.472 0.472 0.472	0.472 0.472 0.472	TJ_H_D754 TJ_J_D854 TJ_F_D556	0.484 0.484 0.484	3.611 3.611 3.736	3.548 3.548 3.673
3.500 3.500 3.500	4.250 4.375 4.500	0.472 0.472 0.472	0.472 0.472 0.472	TJ_G_D656 TJ_H_D756 TJ_J_D856	0.484 0.484 0.484	3.736 3.736 3.736	3.673 3.673 3.673
3.625 3.625 3.625	4.250 4.375 4.500	0.472 0.472 0.472	0.472 0.472 0.472	TJ_F_D558 TJ_G_D658 TJ_H_D758	0.484 0.484 0.484	3.861 3.861 3.861	3.798 3.798 3.798

Sealing lips may, in some cases, protrude beyond the edge of the seal body.

Sizes printed in **bold** are preferred. Sizes not stated on these tables are available on request (note this will include a tooling charge).



Sizes				TSS Part No.	Sizes		
d1 [inch]	d2 [inch]	b [inch]	b [inch] TJB		b1 min. [inch]	d4 max. [inch]	d5 min. [inch]
3.625 3.750 3.750	4.625 4.375 4.500	0.472 0.472 0.472	0.472 0.472 0.472	TJ_J_D858 TJ_F_D560 TJ_G_D660	0.484 0.484 0.484	3.861 3.986 3.986	3.798 3.923 3.923
3.750 3.750 3.875	4.625 4.750 4.500	0.472 0.472 0.472	0.472 0.472 0.472	TJ_H_D760 TJ_J_D860 TJ_F_D562	0.484 0.484 0.484	3.986 3.986 4.111	3.923 3.923 4.048
3.875 3.875 3.875	4.625 4.750 4.875	0.472 0.472 0.472	0.472 0.472 0.472	TJ_G_D662 TJ_H_D762 TJ_J_D862	0.484 0.484 0.484	4.111 4.111 4.111	4.048 4.048 4.048
4.000 4.000 4.000	4.625 4.750 4.875	0.472 0.472 0.472	0.472 0.472 0.472	TJ_F_D564 TJ_G_D664 TJ_H_D764	0.484 0.484 0.484	4.236 4.236 4.236	4.173 4.173 4.173
4.000 4.125 4.125	5.000 4.750 4.875	0.472 0.472 0.472	0.472 0.472 0.472	TJ_J_D864 TJ_F_D566 TJ_G_D666	0.484 0.484 0.484	4.236 4.361 4.361	4.173 4.298 4.298
4.125 4.125	5.000 5.125	0.472 0.472	0.472 0.472	TJ_H_D766 TJ_J_D866	0.484 0.484	4.361 4.361	4.298 4.298

Sealing lips may, in some cases, protrude beyond the edge of the seal body.

Sizes printed in **bold** are preferred. Sizes not stated on these tables are available on request (note this will include a tooling charge).



Ordering Information

An ordering example is shown below.

Ordering example

Standard, Type A/Type 1

Shaft diameter d1 = 30 mm (1.181 in)

Outside diameter d2 = 47 mm (1.85 in)

Width b = 7 mm (0.276 in)

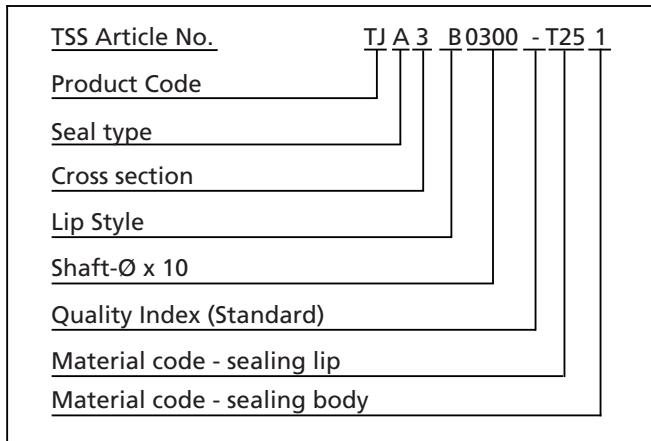

Order as: TJA380300-T251V

Type: A, B, C, D or G
1, 3, 4, 5 or 6

Cross Section: 1, 2, 3, 4, 5, 6 or 7
Refer to Table of Sizes

Lip Style: A, B, or C
(Shaft rotation viewed from airside)
A anti-clockwise shaft
B bi-directional shaft
C clockwise shaft

Shaft x 10: Refer to Table of Sizes

Quality Index: - for standard parts
A for aerospace parts

Lip Material: Refer to Materials section

Case Material: 1*

* Other materials available on request

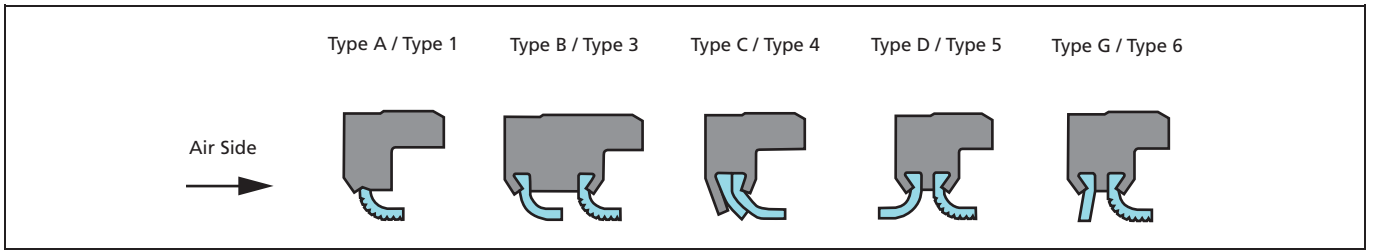
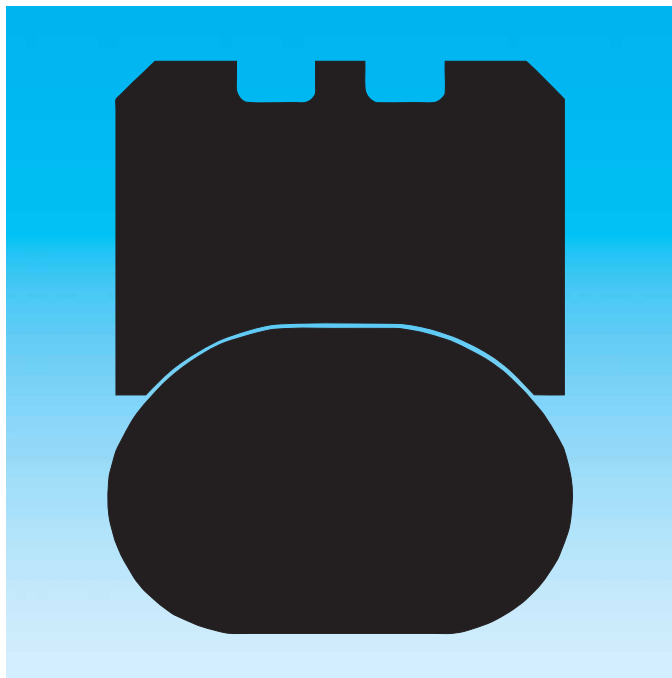

Figure 110 Product Range



Turcon[®] Roto Glyd Ring[®]







■ TURCON® ROTARY SEALS - ELASTOMER ENERGIZED

■ Turcon® Roto Glyd Ring®

Description

The Turcon® Roto Glyd Ring® is used to seal rods, shafts, axles, bores, rotary transmission leadthroughs, journals, swivels etc. with rotary or oscillating movement.

The seal is double-acting and can be exposed to pressure from one, or from both sides.

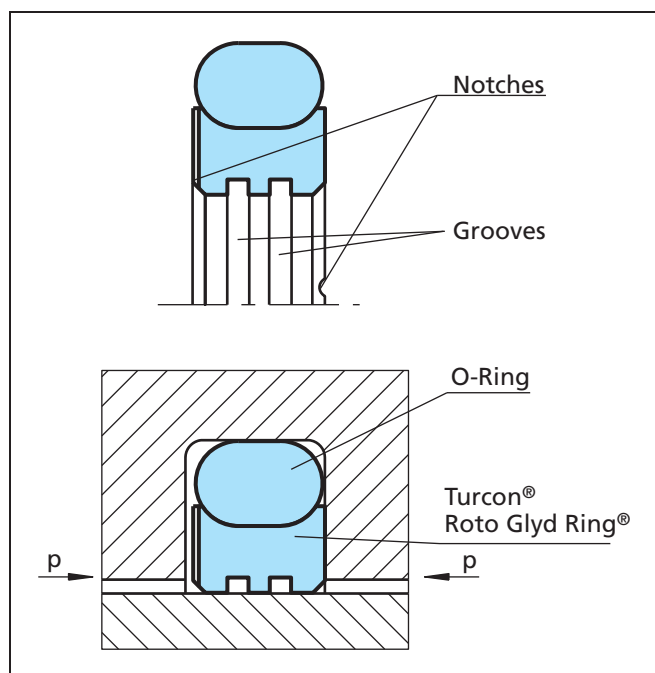

Figure 111 Turcon® Roto Glyd Ring®

It consists of a seal ring of Turcon® material and is activated by an O-Ring as an elastic energizing element.

The contact surface profile of the seal ring is specially designed for use under high pressures and at low sliding speeds.

Depending on the profile cross-section of the seal, the contact surface has one or two continuous machined grooves. These have the following functions:

- Improved seal efficiency by increasing the specific surface load pressure against the sealed surface
- Formation of lubricant reservoir and reduction in friction.

In order to improve the pressure activation of the O-Ring, the Roto Glyd Ring® has notched end faces as standard.

The rear face which holds the O-Ring has a concave form. This increases the contact surface and shall prevent the seal from turning with the rotating surface.

A standard diameter range for each profile size is assigned to the series numbers in Table LXXVI and LXXVIII. This recommendation applies to all new constructions. Different dimensions are available on request.

Advantages

- Available for internal and external sealing applications
- Low friction
- Stick-slip-free starting, no sticking
- High abrasion resistance and dimensional stability
- Simple groove design, small groove dimensions
- Lubricant reservoir
- Available in all sizes up to 2700 mm diameter (to 2600 mm for rod seals)

Technical data

Operating pressure:	Up to 30 MPa
Speed:	Up to 2 m/s
Temperature:	- 45°C to + 200 °C *) (depending on O-Ring material)
Media:	Mineral oil-based hydraulic fluids, flame retardant hydraulic fluids, environmentally safe hydraulic fluids (bio-oils), water, air and others, depending on O-Ring material.

Note: For continuous operation at temperatures over +60 °C, pressure and speed must be limited.

Important Note:

The above data are maximum values and cannot be used at the same time, e. g. the maximum operating speed depends on material type, pressure and temperature.

*) Important Note:

In the case of unpressurized applications in temperatures below 0°C please contact our application engineers for assistance!



Frictional power

Guide values for the frictional power can be determined from the graph in Figure 112. They are shown as a function of the sliding speed and operating pressure for a shaft diameter of 50 mm with an oil temperature of 60° C. At higher temperatures, these application limits must be reduced.

Guide values for other shaft diameters can be calculated using the formula:

$$P \approx P_{50} \times \left(\frac{d}{50 \text{ mm}} \right) [W]$$

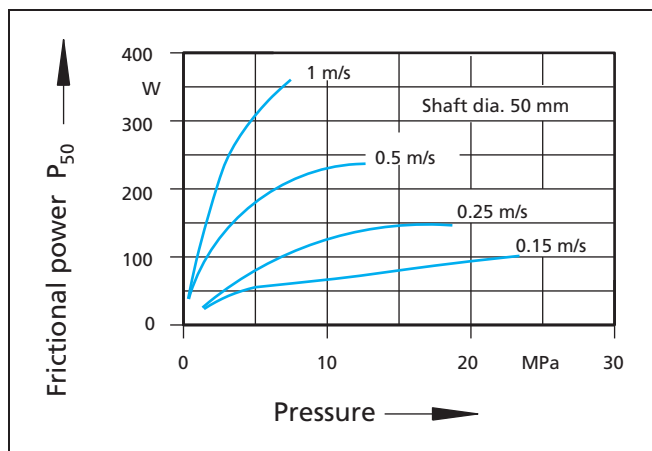

Figure 112 Frictional power for Turcon[®] Roto Glyd Ring[®]

The guide values apply for constant operating conditions. Changes in operating conditions such as pressure fluctuations or alternating directions of shaft rotation can result in considerably higher friction values.

Application examples

The Turcon[®] Roto Glyd Ring[®] is preferably used as a double acting rotary seal for hydraulic and pneumatic equipment in sectors such as:

- Rotary distributors
- High pressure valve stems
- Manipulators
- Pivoting motors in mobile hydraulic and machine tools
- Hydraulic motors

Application limits

The maximum application data for temperature, pressure and speed given in this catalogue have a mutual effect on one another and can thus not be exploited simultaneously.

Seal performance is further influenced by such factors as lubrication capability of the sealed medium and heat dissipation in the hardware, it follows that testing should always be made.

With good lubrication, the following pv value can be assumed as guide:

Turcon[®] Roto Glyd Ring[®]: up to $p_v = 2.5 \text{ MPa} \cdot \text{m/s}$

The value must be reduced for diameters < 50 mm.

Lead-in chamfers

In order to avoid damage during installation, lead-in chamfers and rounded edges must be provided on the housing and on the rod (Figures 124 and 125). If this is not possible for design reasons, a separate installation tool is recommended.

The minimum length of the lead-in chamfer depends on the profile size of the seal and can be seen from the following tables. If concentricity between the parts is not ensured during installation the lead-in chamfers must be increased correspondingly.

For the surface quality of the lead-in chamfer, the same recommendations apply as given for the sealing surfaces in Table LXXV.

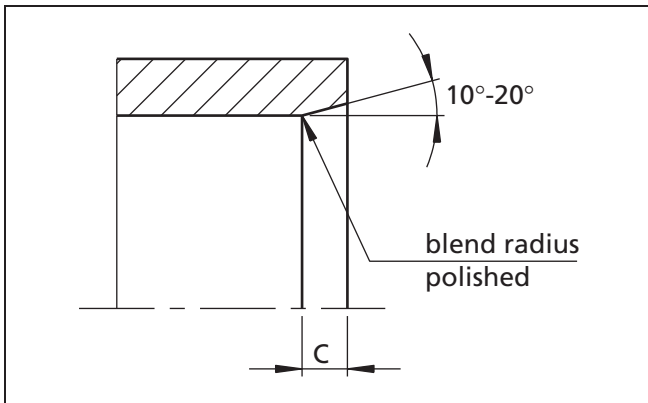

Figure 113 Lead-in chamfer on bore

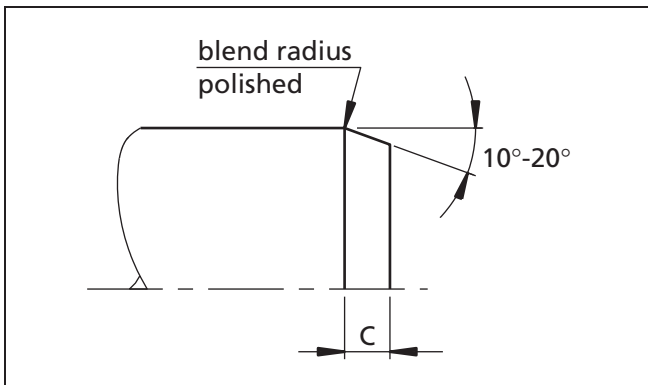

Figure 114 Lead-in chamfer on rod

Table LXXII Lead-in chamfers for Turcon® Roto Glyd Ring®

Series No.		Lead-in chamfers length C min.
Bore	Rod	
TG40	TG30	2.0
TG41	TG31	2.5
TG42	TG32	3.5
TG43	TG33	5.0
TG44	TG34	6.5
TG45	TG35	7.5

Table LXXIII Surface roughness

Parameter	Surface roughness μm	
	Mating surface	
	Turcon® materials	Groove surface
R_{max}	0.63 - 2.50	< 16.0
R_z DIN	0.40 - 1.60	< 10.0
R_a	0.05 - 0.20	< 1.6

The material contact area R_{mr} should be approx. 50 to 70%, determined at a cut depth $c = 0.25 \times R_z$, relative to a reference line of C_{ref} . 5%.

For ceramic coated surfaces, like plasma sprayed, additional focus on surface texture is necessary. Peaks and sharp edges from pores have to be polished away (e.g. with diamond paste on soft "pad") to avoid premature seal wear.

Closed grooves

Turcon® Roto Glyd Ring® for external and internal sealing can be installed in closed grooves at diameters from $\varnothing 15$ and $\varnothing 12$ respectively. Seal cross sections used outside of their recommended diameter range require split grooves according to table below.

Table LXXIV Groove type - closed or split

Series	Series	Split grooves required below	
Bore	Rod	Turcite® T40	Turcite® T10
TG40	-	$\varnothing 15$	$\varnothing 25$
TG41	-	$\varnothing 25$	$\varnothing 38$
TG42	-	$\varnothing 32$	$\varnothing 50$
TG43	-	$\varnothing 50$	$\varnothing 75$
-	TG30	$\varnothing 20$	
-	TG31	$\varnothing 30$	
-	TG32	$\varnothing 40$	
-	TG33	$\varnothing 60$	



■ Installation of Turcon® Roto Glyd Ring®

Installation instructions

The following points should be observed before installation of the seals:

- Check whether housing or rod has a lead-in chamfer; if not, use an installation sleeve
- Deburr and chamfer or round sharp edges, cover the tips of any screw threads
- Remove machining residues such as chips, dirt and other foreign particles and carefully clean all parts
- The seals can be installed more easily if they are greased or oiled. Attention must be paid to the compatibility of the seal materials with these lubricants. Use only grease without solid additives (e.g. molybdenum disulfide or zinc sulfide)
- Do not use installation tools with sharp edges

Installation of Turcon® Roto Glyd Ring® in split grooves

“Internal and external sealing”

Installation in split grooves is simple. During final assembly - insertion of the rod - the Turcon® Roto Glyd Ring® must be sized. The rod itself can be used for this purpose, provided it has a long lead-in chamfer. Alternatively a corresponding mandrel can be used.

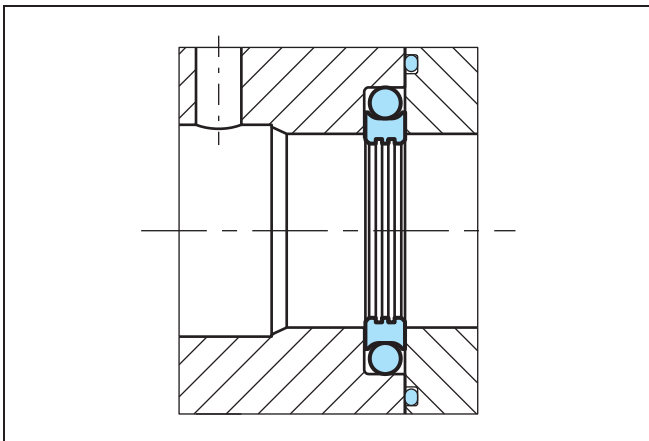

Figure 115 Installation in a split groove

The following installation sequence is recommended:

- Pull the O-Ring onto the Roto Glyd Ring®
- Press the seal element into the groove. The O-Ring must not be allowed to twist

Installation of Turcon® Roto Glyd Ring® in closed grooves

“Internal sealing”

The installation of our seal elements is unproblematic.

- Place the O-Ring into the groove (avoid twisting the ring!)
- Compress the Turcon® Roto Glyd Ring® into a kidney shape. The seal must have no sharp bends

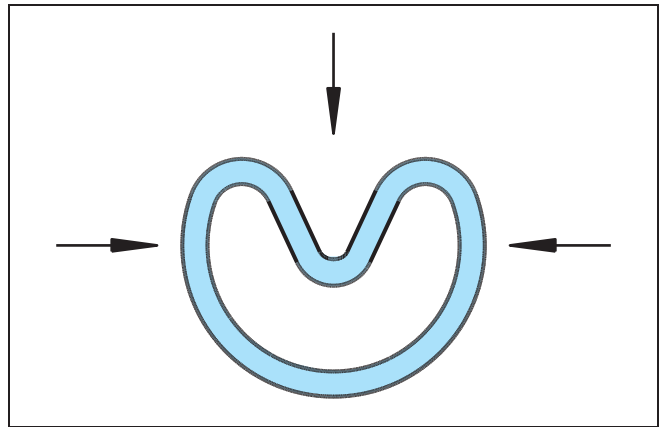

Figure 116 Kidney-shaped deformation of the seal ring

- Place the seal ring in compressed form into the groove and push against the O-Ring in the direction of the arrow.

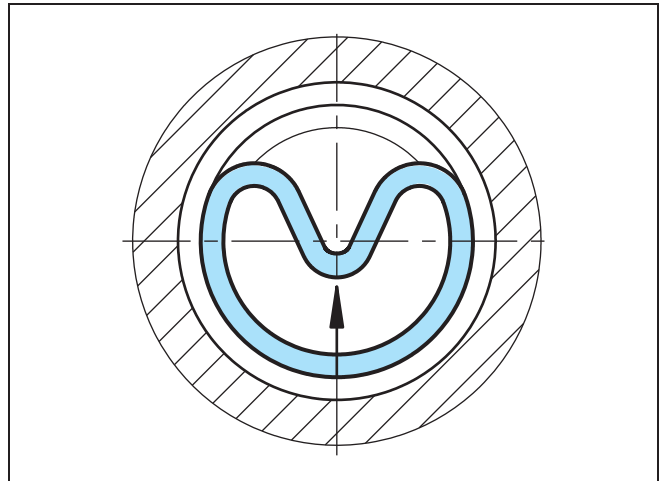

Figure 117 Inserting the seal ring into the closed groove

- Finally size the seal ring using a mandrel which should have a chamfer of 10° to 15° over a length of approx. 30 mm

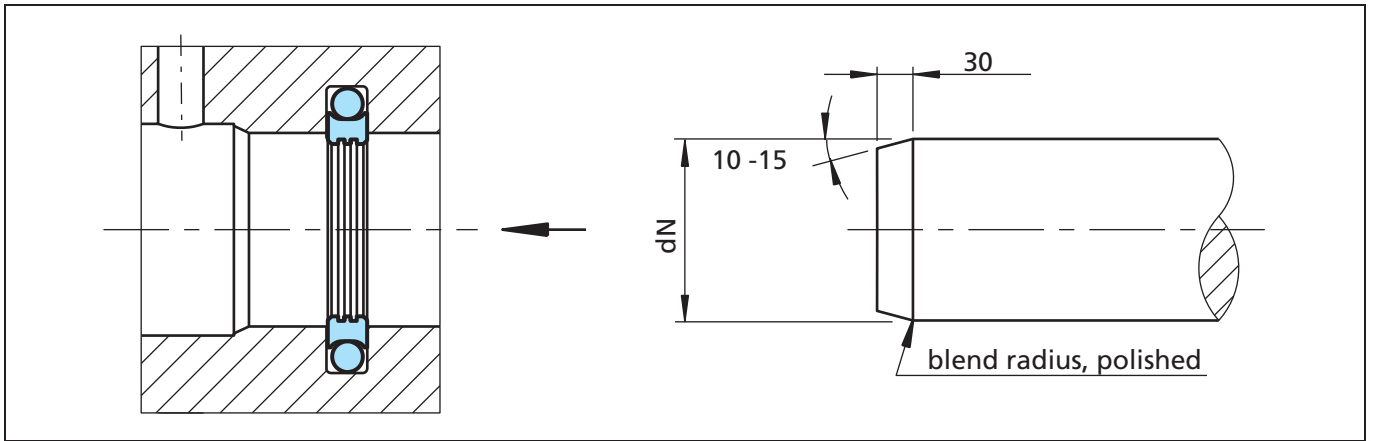

Figure 118 Sizing of the installed seal

The rod itself can also be used for sizing, provided that it has a sufficiently long lead-in chamfer as per our recommendations in Table LXXII.

Sizing mandrels should be made from a polymer material (e.g. polyamide). In order to avoid damage to the seals, a smooth surface with rounded and polished lead-in chamfer is necessary.

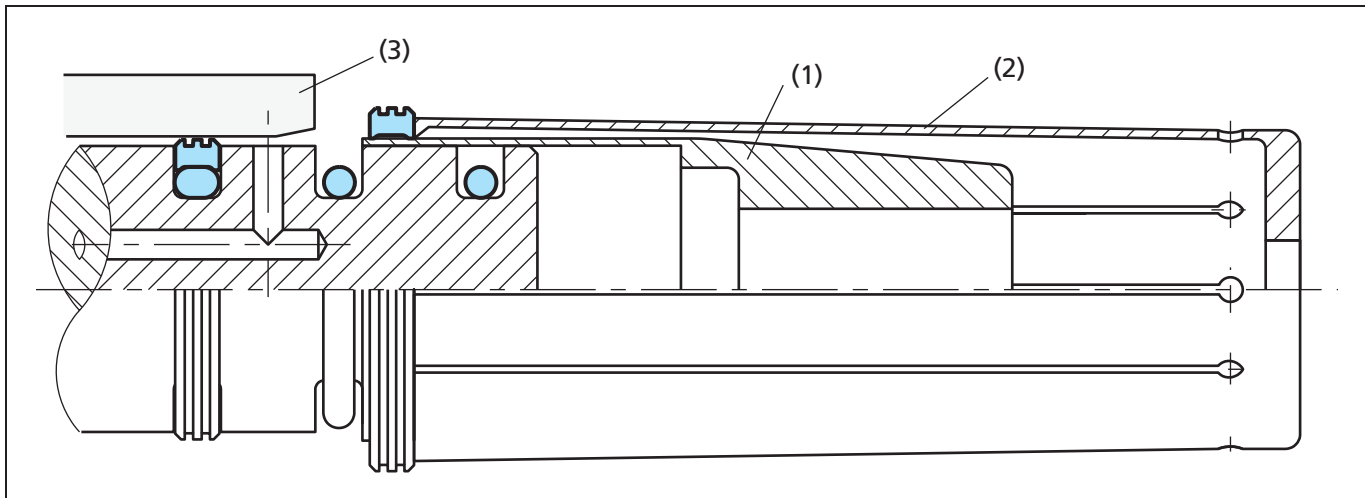

Figure 119 Expanding the Turcon[®] Roto Glyd Ring[®] over the installation sleeve using an expanding sleeve

Installation with installation tools (external sealing)

Use of a three-piece installation tool is recommended for series production installation of the Turcon[®] Roto Glyd Ring[®].

The tool consists of:

- Installation sleeve (1)
- Expanding sleeve (2)
- Sizing sleeve (3).

All parts should be made of a polymer material (e.g. polyamide) with a good surface finish to avoid damage to the seals.

The O-Ring should be pulled over the piston into the groove (take care not to burst the O-Ring).

The Roto Glyd Ring[®] element should be expanded over the Installation sleeve using the Expanding sleeve using a fast but smooth movement.

After installation the Roto Glyd Ring[®] element should be sized using the Sizing sleeve.

In view of the large number of sizes and the application-specific installation conditions, this installation tool cannot be supplied as standard by Trelleborg Sealing Solutions.

Drawings for installation tools are available on request.

Installation without installation tools (external sealing)

If installation has to be performed without installation tools, however, the following points should be observed:

- The Roto Glyd Ring[®] can be installed more easily by heating in oil, water or using a hot air fan to approx. 80° C to 100° C (expanding and then sizing)
- Use no sharp edged tools to expand the seal rings
- Installation should be performed as quickly as possible so that an optimum snap-back of the seal element is assured
- Sizing of the seal ring can be carried out in the corresponding housing, provided that it has a long lead-in chamfer as per Table LXXII. Otherwise use a sizing sleeve.



Materials

Standard materials:

Turcon® seal ring: Turcon® T10 and Turcon® T40
 O-Ring: NBR, 70 Shore A

For specific applications, other material combinations as listed in Table LXXV.

Table LXXV Standard Turcon® materials for Turcon® Roto Glyd Ring®

Material, applications, properties	Code	O-Ring material	Code	O-Ring operating temp.* °C	Mating surface material	MPa max.
Turcon® T10 Hydraulics and pneumatics for all lubricating and non-lubricating fluids, high extrusion resistance, good chemical resistance, BAM. Carbon, graphite filled Color: Black	T10	NBR - 70 Shore A	N	-30 to +100	Steel Steel, Chrome plated Stainless steel	30
		NBR - Low temp. 70 Shore A	T	-45 to +80		
		FKM - 70 Shore A	V	-10 to +200		
		EPDM-70 Shore A	E**	-45 to +145		
Turcon® T40 For all lubricating and non-lubricating hydraulic fluids, water hydraulics, soft mating surfaces. Carbon fiber filled Color: Grey	T40	NBR - 70 Shore A	N	-30 to +100	Steel Steel, Chrome plated Cast iron Stainless steel, Aluminum Bronze Alloys	20
		NBR - Low temp. 70 Shore A	T	-45 to +80		
		FKM - 70 Shore A	V	-10 to +200		
		EPDM-70 Shore A	E**	-45 to +145		

* The O-Ring Operation Temperature is only valid in mineral hydraulic oil.

** Material not suitable for mineral oils.

BAM: Approved by "Bundes Anstalt Materialprüfung, Germany".

Highlighted materials are standard.



■ Installation recommendation - external sealing

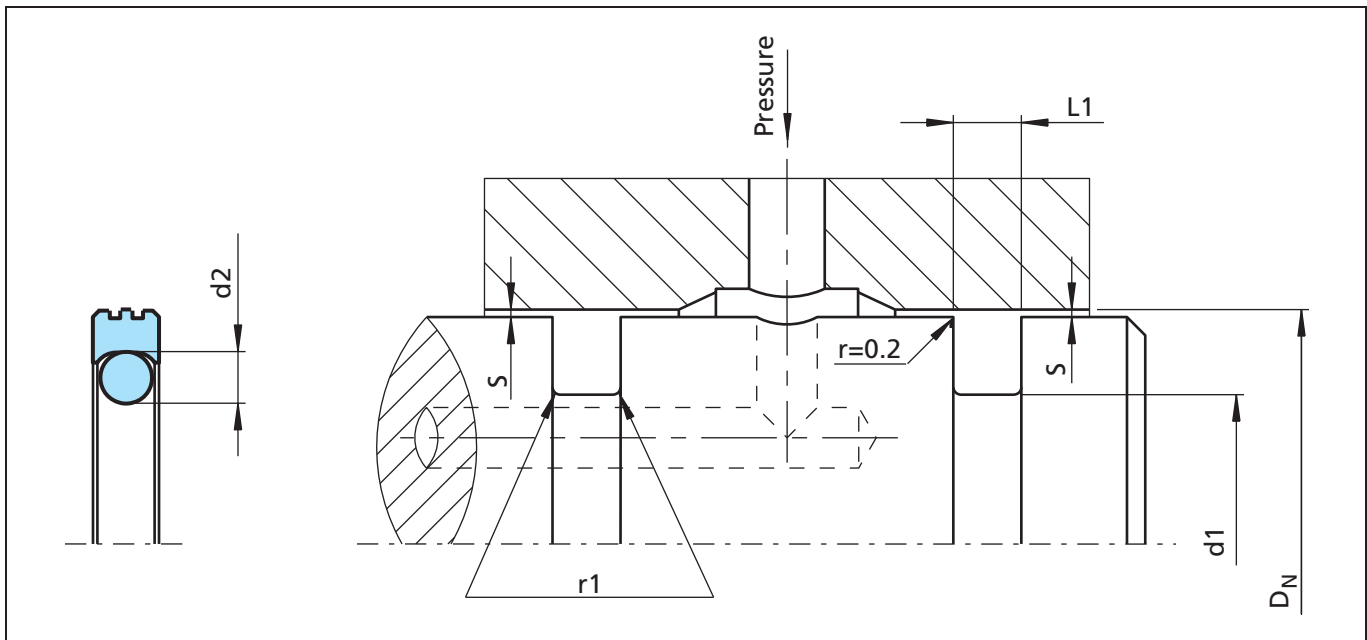

Figure 120 Installation drawing

Table LXXVI Installation dimensions

Series no.	Bore diameter D _N H9		Groove diameter d ₁ h9	Groove width L ₁ +0.2	Radial clearance S max. *		Radius r ₁	O-Ring cross sec. d ₂	Number of grooves in the sealing surface
	Standard range	Available range			10 MPa	20 MPa			
TG40	8 - 39.9	8 - 135.0	D _N - 4.9	2.20	0.15	0.10	0.40	1.78	0
TG41	40 - 79.9	14 - 250.0	D _N - 7.5	3.20	0.20	0.15	0.60	2.62	1
TG42	80 - 132.9	22 - 460.0	D _N - 11.0	4.20	0.25	0.20	1.00	3.53	1
TG43	133 - 329.9	40 - 675.0	D _N - 15.5	6.30	0.30	0.25	1.30	5.33	2
TG44	330 - 669.9	133 - 690.0	D _N - 21.0	8.10	0.30	0.25	1.80	7.00	2
TG45	670 - 999.9	670 - 999.9	D _N - 28.0	9.50	0.45	0.30	2.50	8.40	2

Provide split housing grooves according to diameter, see Table LXXIV.

At pressures > **10 MPa** it is recommended that for the cross section you choose the next larger profile according to the column "Available Range" i.e. for bore Ø80 mm: TG 43 00 800-.

* At pressures > **30 MPa**: Use diameter tolerance H8/f8 (bore / rod) in area of seal.



Ordering Example

Turcon® Roto Glyd Ring®, complete with O-Ring, external sealing, series TG42 (from Table LXXVI).

Bore diameter: $D_N = 80.0$ mm
TSS Part No.: TG4200800 (from Table LXXVII)

Select the material from Table LXXV. The corresponding code numbers are appended to the TSS Part No. (from Table LXXVII). Together they form the TSS Article No.

For all intermediate sizes not shown in Table LXXVIII, the Order No. can be determined from the example opposite.

** For diameters ≥ 1000.0 mm multiply only by factor 1.
Example: TG45 for diameter 1200.0 mm.
TSS Article No.: TG45**X1200** - T40N.

TSS Article No.	TG42	0	0800	-	T40	N
TSS Series No.						
Type (Standard)						
Cylinder diameter x 10**						
Quality Index (Standard)						
Material code (Seal ring)						
Material code (O-Ring)						

Table LXXVII Preferred Dimension / TSS Part No.

Bore diameter	Groove diameter	Groove width	TSS Part No.	O-Ring size
D_N H9	d_1 h9	$L_1 +0.2$		
8.0	3.1	2.2	TG4000080	2.90 x 1.78
10.0	5.1	2.2	TG4000100	4.80 x 1.8
12.0	7.1	2.2	TG4000120	6.70 x 1.8
14.0	9.1	2.2	TG4000140	8.75 x 1.8
15.0	10.1	2.2	TG4000150	9.25 x 1.78
16.0	11.1	2.2	TG4000160	10.82 x 1.78
18.0	13.1	2.2	TG4000180	12.42 x 1.78
20.0	15.1	2.2	TG4000200	14.00 x 1.78
22.0	17.1	2.2	TG4000220	17.17 x 1.78
25.0	20.1	2.2	TG4000250	18.77 x 1.78
28.0	23.1	2.2	TG4000280	21.95 x 1.78
30.0	25.1	2.2	TG4000300	25.12 x 1.78
32.0	27.1	2.2	TG4000320	26.70 x 1.78
35.0	30.1	2.2	TG4000350	29.87 x 1.78
40.0	32.5	3.2	TG4100400	31.42 x 2.62
42.0	34.5	3.2	TG4100420	32.99 x 2.62
45.0	37.5	3.2	TG4100450	36.17 x 2.62
48.0	40.5	3.2	TG4100480	39.34 x 2.62
50.0	42.5	3.2	TG4100500	40.94 x 2.62
52.0	44.5	3.2	TG4100520	44.12 x 2.62
55.0	47.5	3.2	TG4100550	45.69 x 2.62

The bore diameters printed in **bold** type conform to the recommendations of ISO 3320.
Other dimensions and all intermediate sizes up to 2.700 mm diameter including inch sizes can be supplied.



Turcon® Roto Glyd Ring®

Bore diameter	Groove diameter	Groove width	TSS Part No.	O-Ring size
D_N H9	d_1 h9	$L_1 +0.2$		
60.0	52.5	3.2	TG4100600	52.07 x 2.62
63.0	55.5	3.2	TG4100630	53.64 x 2.62
65.0	57.5	3.2	TG4100650	56.82 x 2.62
70.0	62.5	3.2	TG4100700	61.60 x 2.62
75.0	67.5	3.2	TG4100750	66.34 x 2.62
80.0	69.0	4.2	TG4200800	66.27 x 3.53
85.0	74.0	4.2	TG4200850	72.62 x 3.53
90.0	79.0	4.2	TG4200900	78.97 x 3.53
95.0	84.0	4.2	TG4200950	82.14 x 3.53
100.0	89.0	4.2	TG4201000	88.49 x 3.53
105.0	94.0	4.2	TG4201050	91.67 x 3.53
110.0	99.0	4.2	TG4201100	98.02 x 3.53
115.0	104.0	4.2	TG4201150	101.19 x 3.53
120.0	109.0	4.2	TG4201200	107.54 x 3.53
125.0	114.0	4.2	TG4201250	113.89 x 3.53
130.0	119.0	4.2	TG4201300	117.07 x 3.53
135.0	119.5	6.3	TG4301350	116.84 x 5.33
140.0	124.5	6.3	TG4301400	123.19 x 5.33
150.0	134.5	6.3	TG4301500	132.72 x 5.33
160.0	144.5	6.3	TG4301600	142.24 x 5.33
170.0	154.5	6.3	TG4301700	151.77 x 5.33
180.0	164.5	6.3	TG4301800	164.47 x 5.33
190.0	174.5	6.3	TG4301900	170.82 x 5.33
200.0	184.5	6.3	TG4302000	183.52 x 5.33
210.0	194.5	6.3	TG4302100	189.87 x 5.33
220.0	204.5	6.3	TG4302200	202.57 x 5.33
230.0	214.5	6.3	TG4302300	208.92 x 5.33
240.0	224.5	6.3	TG4302400	221.62 x 5.33
250.0	234.5	6.3	TG4302500	234.32 x 5.33
280.0	264.5	6.3	TG4302800	266.07 x 5.33
300.0	284.5	6.3	TG4303000	278.77 x 5.33
320.0	304.5	6.3	TG4303200	304.17 x 5.33
350.0	329.0	8.1	TG4403500	329.57 x 7.00
400.0	379.0	8.1	TG4404000	267.67 x 7.00
420.0	399.0	8.1	TG4404200	393.07 x 7.00
450.0	429.0	8.1	TG4404500	417.96 x 7.00

The bore diameters printed in **bold** type conform to the recommendations of ISO 3320.
Other dimensions and all intermediate sizes up to 2.700 mm diameter including inch sizes can be supplied.



Bore diameter	Groove diameter	Groove width	TSS Part No.	O-Ring size
D_N H9	d_1 h9	L_1 +0.2		
480.0	459.0	8.1	TG4404800	456.06 x 7.00
500.0	479.0	8.1	TG4405000	468.76 x 7.00
600.0	579.0	8.1	TG4406000	582.68 x 7.00
700.0	672.0	9.5	TG4507000	670.00 x 8.40

The bore diameters printed in **bold** type conform to the recommendations of ISO 3320.
Other dimensions and all intermediate sizes up to 2.700 mm diameter including inch sizes can be supplied.



■ Installation recommendation - internal sealing

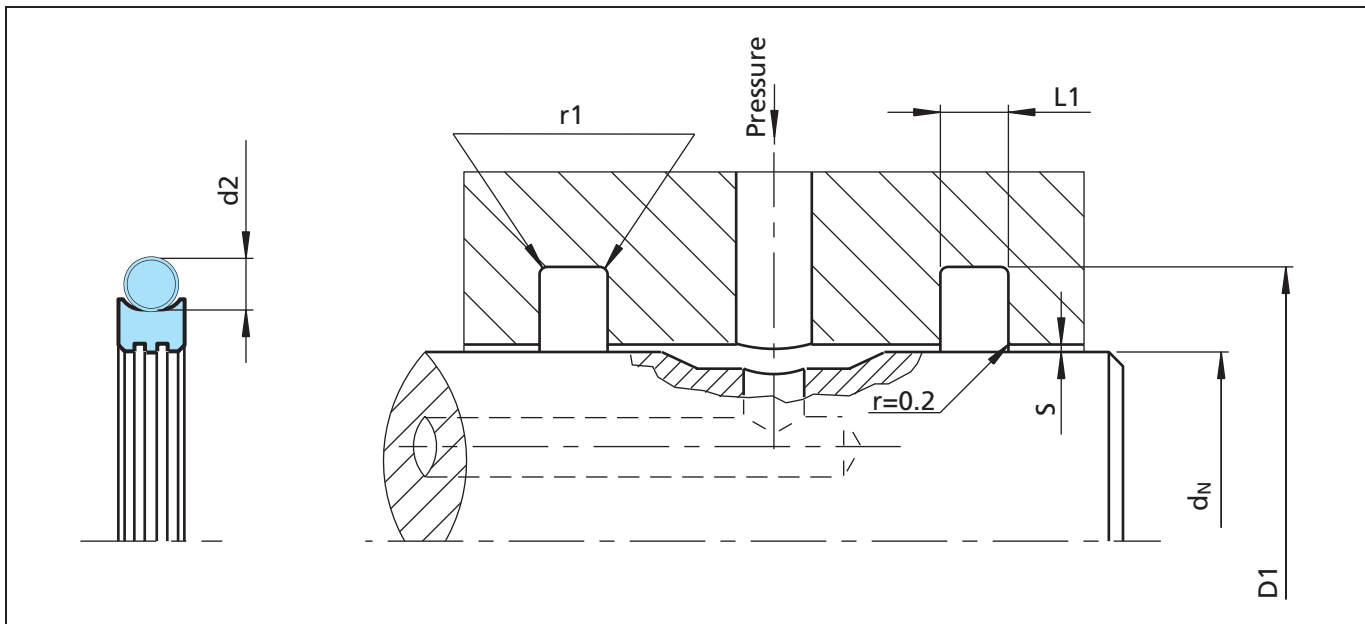

Figure 121 Installation drawing

Table LXXVIII Installation dimensions

Series no.	Rod diameter		Groove diameter	Groove width	Radial clearance S max. *		Radius	O-Ring cross sec.	Number of grooves in the sealing surface
	d_N f8/h9				10 MPa	20 MPa			
	Standard range	Available ¹⁾ range	D_1 H9	$L_1 +0.2$			r_1	d_2	
TG30	6 - 18.9	6 - 130.0	$d_N + 4.9$	2.20	0.15	0.10	0.40	1.78	0
TG31	19 - 37.9	10 - 245.0	$d_N + 7.5$	3.20	0.20	0.15	0.60	2.62	1
TG32	38 - 199.9	19 - 455.0	$d_N + 11.0$	4.20	0.25	0.20	1.00	3.53	1
TG33	200 - 255.9	38 - 655.0	$d_N + 15.5$	6.30	0.30	0.25	1.30	5.33	2
TG34	256 - 649.9	120 - 655.0	$d_N + 21.0$	8.10	0.30	0.25	1.80	7.00	2
TG35	650 - 999.9	650 - 999.9	$d_N + 28.0$	9.50	0.45	0.30	2.50	8.40	2

Provide split housing grooves according to diameter, see Table LXXIV.

At pressures > **10 MPa** it is recommendable that for the cross section you choose the next larger profile according to the column "Available range" i.e. for shaft $\varnothing 80$ mm: TG 33 00 800-.

* At pressures > **30 MPa**: Use diameter tolerance H8/f8 (bore / rod) in area of seal.



Ordering example

Turcon® Roto Glyd Ring®, complete with O-Ring, internal sealing, series TG32 (from Table LXXVIII).

Rod diameter: $d_N = 80.0$ mm
 TSS Part No.: TG3200800 (from Table LXXIX)

Select the material from Table LXXV. The corresponding code numbers are appended to the TSS Part No. Together they form the TSS Article No.

For all intermediate sizes not shown in Table LXXVIII, the TSS Article No. can be determined from the example below.

** For diameters ≥ 1000.0 mm multiply only by factor 1.
 Example: TG35 for diameter 1200.0 mm.
 TSS Article No.: TG35X1200 - T40N.

TSS Article No.	TG32	0	0800	-	T40	N
TSS Series No.						
Type (Standard)						
Rod diameter x 10**						
Quality Index (Standard)						
Material code (Seal ring)						
Material code (O-Ring)						

Table LXXIX Preferred Dimension / TSS Part No.

Rod diameter	Groove diameter	Groove width	TSS Part No.	O-Ring size
d_N f8/h9	D_1 H9	L_1 +0.2		
6.0	10.9	2.2	TG3000060	7.65 x 1.78
8.0	12.9	2.2	TG3000080	9.5 x 1.8
10.0	14.9	2.2	TG3000100	11.8 x 1.8
12.0	16.9	2.2	TG3000120	14.00 x 1.78
14.0	18.9	2.2	TG3000140	15.60 x 1.78
15.0	19.9	2.2	TG3000150	17.17 x 1.78
16.0	20.9	2.2	TG3000160	17.17 x 1.78
18.0	22.9	2.2	TG3000180	18.77 x 1.78
20.0	27.5	3.2	TG3100200	21.89 x 2.62
22.0	29.5	3.2	TG3100220	25.07 x 2.62
25.0	32.5	3.2	TG3100250	28.24 x 2.62
28.0	35.5	3.2	TG3100280	31.42 x 2.62
30.0	37.5	3.2	TG3100300	32.99 x 2.62
32.0	39.5	3.2	TG3100320	34.59 x 2.62
35.0	42.5	3.2	TG3100350	37.77 x 2.62
36.0	43.5	3.2	TG3100360	39.34 x 2.62
40.0	51.0	4.2	TG3200400	44.04 x 3.53
42.0	53.0	4.2	TG3200420	47.22 x 3.53
45.0	56.0	4.2	TG3200450	50.39 x 3.53
48.0	59.0	4.2	TG3200480	53.57 x 3.53
50.0	61.0	4.2	TG3200500	53.57 x 3.53

The rod diameters printed in **bold** type conform to the recommendations of ISO 3320.
 Other dimensions and all intermediate sizes up to 2.600 mm diameter including inch sizes can be supplied.



Turcon® Roto Glyd Ring®

Rod diameter	Groove diameter	Groove width	TSS Part No.	O-Ring size
d_N f8/h9	D_1 H9	L_1 +0.2		
52.0	63.0	4.2	TG3200520	56.74 x 3.53
55.0	66.0	4.2	TG3200550	59.92 x 3.53
56.0	67.0	4.2	TG3200560	59.92 x 3.53
60.0	71.0	4.2	TG3200600	63.09 x 3.53
63.0	74.0	4.2	TG3200630	66.27 x 3.53
65.0	76.0	4.2	TG3200650	69.44 x 3.53
70.0	81.0	4.2	TG3200700	75.79 x 3.53
75.0	86.0	4.2	TG3200750	78.97 x 3.53
80.0	91.0	4.2	TG3200800	85.32 x 3.53
85.0	96.0	4.2	TG3200850	88.49 x 3.53
90.0	101.0	4.2	TG3200900	94.84 x 3.53
95.0	106.0	4.2	TG3200950	101.19 x 3.53
100.0	111.0	4.2	TG3201000	104.37 x 3.53
105.0	116.0	4.2	TG3201050	110.72 x 3.53
110.0	121.0	4.2	TG3201100	113.89 x 3.53
115.0	126.0	4.2	TG3201150	120.24 x 3.53
120.0	131.0	4.2	TG3201200	123.42 x 3.53
125.0	136.0	4.2	TG3201250	129.77 x 3.53
130.0	141.0	4.2	TG3201300	136.12 x 3.53
135.0	146.0	4.2	TG3201350	139.29 x 3.53
140.0	151.0	4.2	TG3201400	145.64 x 3.53
150.0	161.0	4.2	TG3201500	151.99 x 3.53
160.0	171.0	4.2	TG3201600	164.69 x 3.53
170.0	181.0	4.2	TG3201700	177.39 x 3.53
180.0	191.0	4.2	TG3201800	183.74 x 3.53
190.0	201.0	4.2	TG3201900	196.44 x 3.53
200.0	215.5	6.3	TG3302000	208.92 x 5.33
210.0	225.5	6.3	TG3302100	215.27 x 5.33
220.0	235.5	6.3	TG3302200	227.97 x 5.33
240.0	255.5	6.3	TG3302400	247.02 x 5.33
250.0	265.5	6.3	TG3302500	253.37 x 5.33
280.0	301.0	8.1	TG3402800	291.47 x 7.00
300.0	321.0	8.1	TG3403000	304.17 x 7.00
320.0	341.0	8.1	TG3403200	329.57 x 7.00
350.0	371.0	8.1	TG3403500	354.97 x 7.00
360.0	381.0	8.1	TG3403600	367.67 x 7.00

The rod diameters printed in **bold** type conform to the recommendations of ISO 3320.
Other dimensions and all intermediate sizes up to 2.600 mm diameter including inch sizes can be supplied.



Rod diameter	Groove diameter	Groove width	TSS Part No.	O-Ring size
d_N f8/h9	D₁ H9	L₁ +0.2		
400.0	421.0	8.1	TG3404000	405.26 x 7.00
420.0	441.0	8.1	TG3404200	430.66 x 7.00
450.0	471.0	8.1	TG3404500	456.06 x 7.00
480.0	501.0	8.1	TG3404800	494.16 x 7.00
500.0	521.0	8.1	TG3405000	506.86 x 7.00
600.0	621.0	8.1	TG3406000	608.08 x 7.00
700.0	728.0	9.5	TG3507000	713.00 x 8.40

The rod diameters printed in **bold** type conform to the recommendations of ISO 3320.
Other dimensions and all intermediate sizes up to 2.600 mm diameter including inch sizes can be supplied.



■ Special solutions for rotary applications

The sealing of rotary movements in machine engineering and hydraulics often demands solutions which cannot be achieved using standard seal elements.

On request, we will be pleased to draw up specific seal proposals for your application.

Axial seals

Our extensive Turcon[®] seal range also permits solutions with modified standard seals.

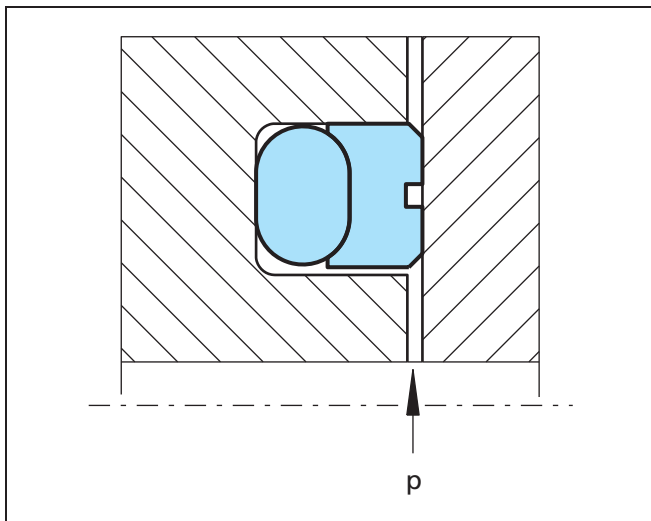

Figure 122 Axial acting Turcon[®] Roto Glyd Ring[®]

Figure 122 shows an axial acting Turcon[®] Roto Glyd Ring[®]. It is pressed axially against the mating surface by the O-Ring. In the same way, a Turcon[®] Stepseal[®] K can also be used here. The max. production diameter is 2700 mm.

The surface roughness of the mating surface must be as specified in Table LXXIII.

Special model with pressure relief

The Roto Glyd Ring[®] can also be supplied with pressure relief grooves. As can be seen in Figure 123 the continuous radial groove is linked on one side to the pressure chamber. The seal is thus relieved of pressure and can be used for higher pv values. The double-acting sealing function is maintained, but the relieved side should be installed on the side with the higher pressure.

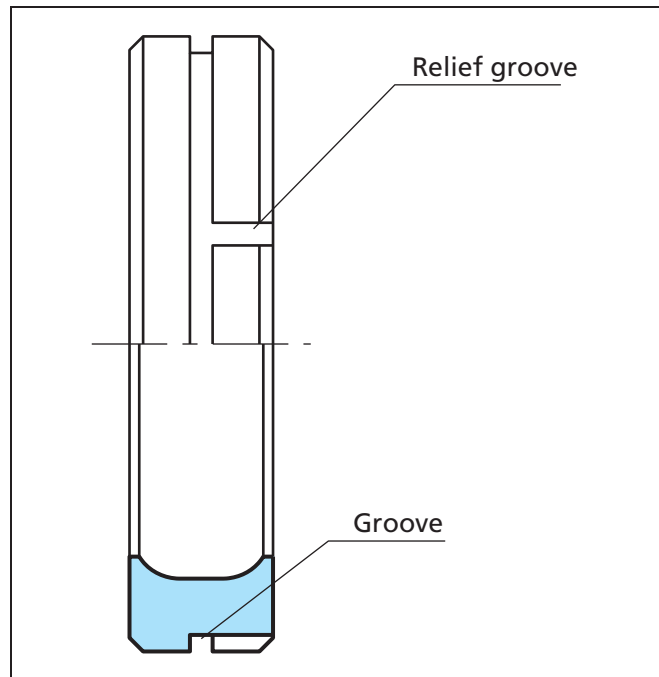
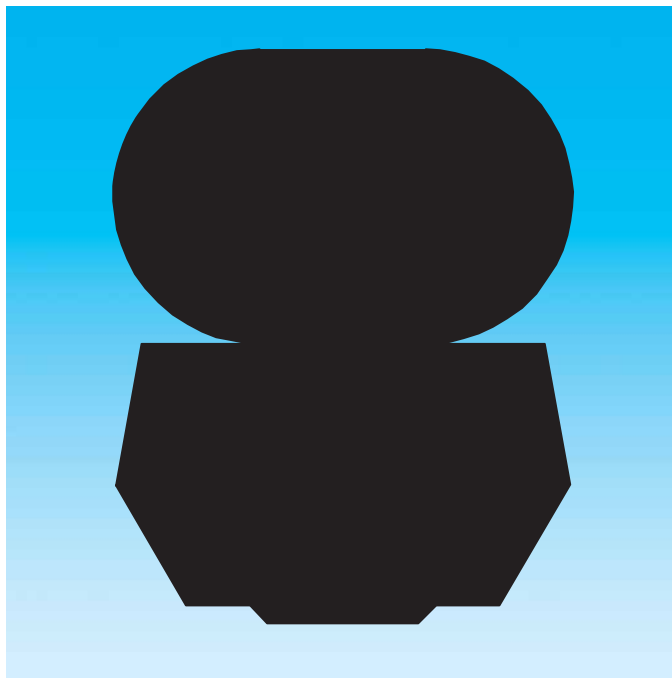

Figure 123 Turcon[®] Roto Glyd Ring[®] with pressure relief

The installation direction must be observed in this case. This version is identified in the article number by a "K" as the 5th digit.

Zurcon[®] Roto Glyd Ring[®] S







■ Zurcon® Roto Glyd Ring® S

Description

The Zurcon® Roto Glyd Ring® S is used to seal shafts, axles, bores, rotary transmission leadthroughs, journals, swivels etc. with rotary or oscillating movement.

The seal is double-acting and can be exposed to pressure from one, or from both sides.

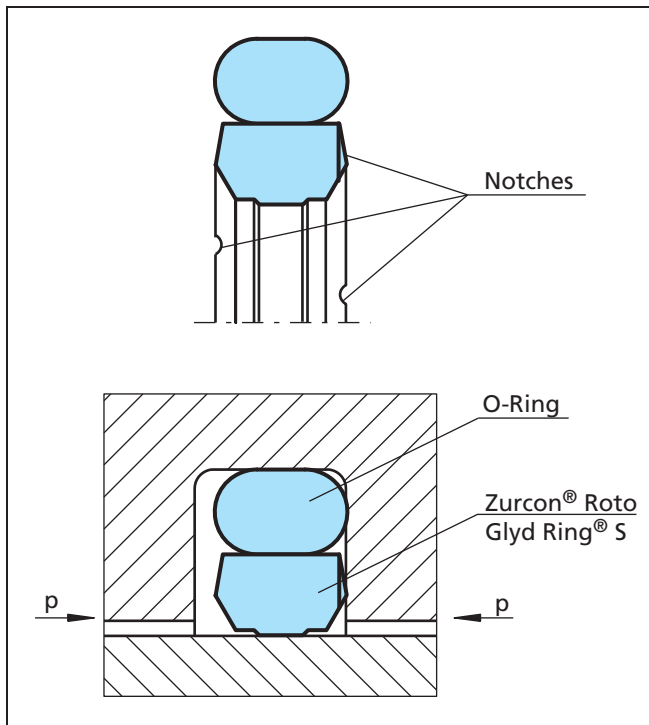

Figure 124 Zurcon® Roto Glyd Ring® S

It consists of a seal ring of Zurcon® material and is activated by an O-Ring as an elastic energizing element.

The contact surface profile of the seal ring is specially designed for use under high pressures and at low sliding speeds.

Pat. pending: DE 101 45914 A1
WO 03/027545 A1

Application examples

- For sealing shafts, axels and rotary transmission leadthroughs with slow rotary or oscillating movement
- Can also be used to seal rotary joints at increased rotating speeds even when exposed to pressure, e.g. rotary indexing tables
- Rotary connections with swivel movement, even when exposed to high pressure, e.g. damping units

Advantages

- Available for shaft and bore sealing applications
- Low friction
- Stick-slip-free starting, no sticking
- High abrasion resistance and dimensional stability
- Simple groove design, small groove dimensions
- Available in material Z51 and Z52 for all shaft sizes up to 2200 mm diameter and for all bore sizes up to 2300 mm
- Available in material Z80 for all shaft sizes up to 2600 mm diameter and for all bore sizes up to 2700 mm



Zurcon[®] Roto Glyd Ring[®] S

Technical data

- Operating pressure: Up to 40 MPa
- Speed: Up to $p \times v$ 6.5 MPa x m/s
- Acceleration: Up to 0.9 m/s², in other cases contact our Technical Office
- Temperature: - 30°C to + 100°C

Material	Pressure p [MPa]	p x v [MPa x m/s]	Temperature t° [°C]
Zurcon [®] Z51*	40	6.5	-30/+100
Zurcon [®] Z52	30	6.5	-30/+100
Zurcon [®] Z80	30	6.5	-30/+80

* Zurcon[®] Z51 only for p >30MPa

- Media:
- Mineral oil base
 - Synthetic and natural ester HEES, HETG up to +60°C
 - Flame-retardant hydraulic fluids HFA, HFC up to +60°C
- Z80 is recommended for sealing e.g. coolants or air

Note: For continuous operation at temperatures over +60°C, pressure and speed must be limited.

Important Note:

The above data are maximum values and cannot be used at the same time. e.g. the maximum operating speed depends on material type, pressure, temperature and gap value. Temperature range also dependent on medium.

Method of operation

Reduced contact surfaces under all operating conditions significantly improve friction and wear characteristics. When exposed to low pressure, only the central section of the seal comes into contact with the mating surface.

As the system pressure increases, the sealing ring is tilted slightly generating the hydrostatic pressure balance in the sealing gap. Tilting the ring under pressure optimizes the lubrication between the seal and the mating surface.

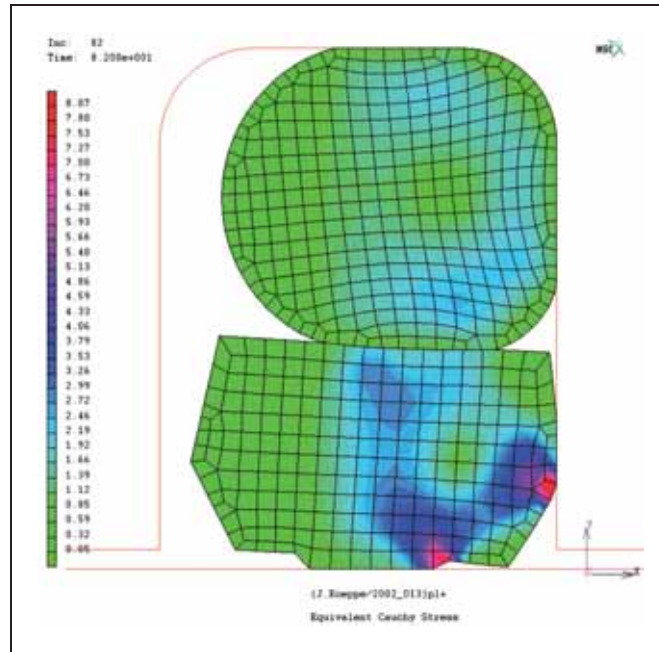

Figure 125 Zurcon[®] Roto Glyd Ring[®] S - Finite Element Analysis (FEA)

The fact that the profile is supported by a second edge restricts contact with the shaft, thereby significantly reducing friction and wear. The material used for the energizing ring can be adapted to suit operating conditions. The angle on both sides of the polyurethane ring prevents extrusion into the extrusion gap.

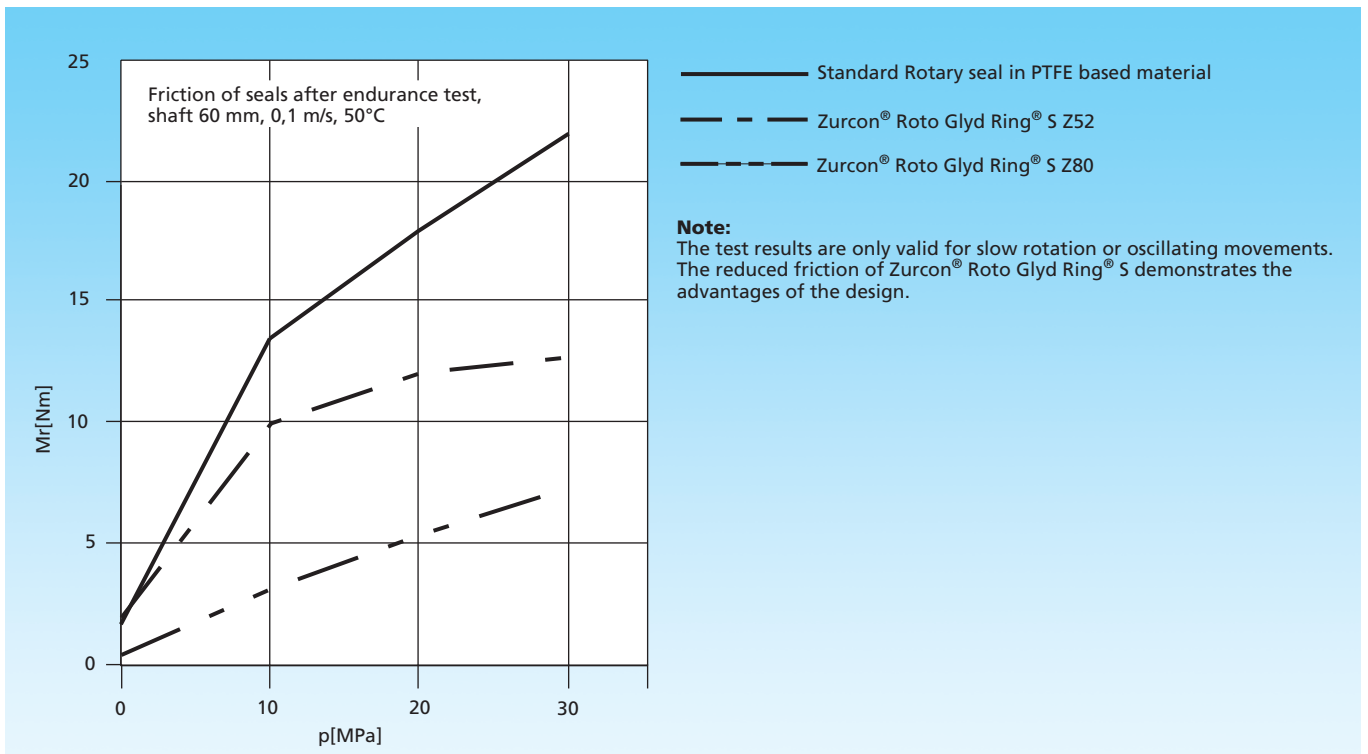

Figure 126 Friction of seals after endurance test

Table LXXX Zurcon[®] Materials for Roto Glyd Ring[®] S

Material, Applications, Properties	Code	O-Ring Material	Code	O-Ring Operating Temp.* °C	Mating Surface Material	MPa max.
Zurcon[®] Z51** For lubricating hydraulic fluids, high abrasion resistance, high extrusion resistance , limited chemical resistance. Cast polyurethane Color: Yellow to light-brown	Z51	NBR - 70 Shore A	N	-30 to +100	Steel	40
		NBR - Low temp. 70 Shore A	T	-45 to +80	Steel, chrome plated Cast iron Ceramic coating Stainless steel	
Zurcon[®] Z52 For lubricating hydraulic fluids, good abrasion resistance, good extrusion resistance , limited chemical resistance. Cast polyurethane Color: Turquoise	Z52	NBR - 70 Shore A	N	-30 to +100	Steel	30
		NBR - Low temp. 70 Shore A	T	-45 to +80	Steel, chrome plated Cast iron Ceramic coating Stainless steel	
Zurcon[®] Z80 For lubricating and non-lubricating hydraulic fluids***, high abrasion resistance, very good chemical resistance, limited temperature resistance. Ultra high molecular weight polyethylene Color: White to off-white	Z80	NBR - 70 Shore A	N	-30 to +80	Steel	30
		NBR - Low temp. 70 Shore A	T	-45 to +80	Steel, chrome plated Stainless steel Aluminum	
		FKM - 70 Shore A	V	-10 to +80	Bronze Ceramic coating	

* The O-Ring Operation Temperature is only valid in mineral hydraulic oil.

** max. Ø 2200 mm

*** e.g. coolant fluids

Highlighted material is standard.



Lead-in chamfers

In order to avoid damage during installation, lead-in chamfers and rounded edges must be provided on the housing and on the shaft (Figures 127 and 128). If this is not possible for design reasons, a separate installation tool is recommended.

The minimum length of the lead-in chamfer depends on the profile size of the seal and can be seen from the following tables. If concentricity between the parts is not ensured during installation the lead-in chamfers must be increased correspondingly.

For the surface quality of the lead-in chamfer, the same recommendations apply as given for the sealing surfaces in Table I.

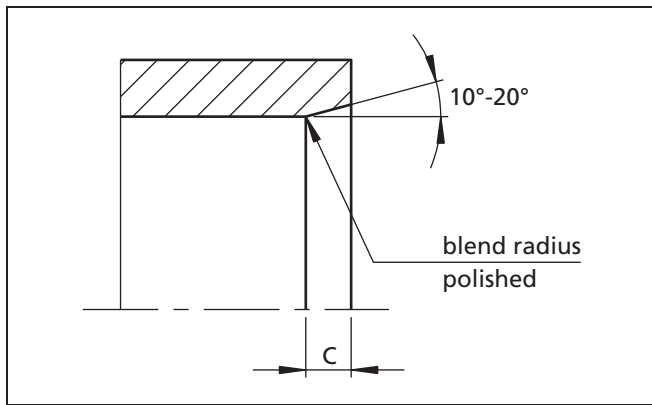

Figure 127 Lead-in chamfer on bore

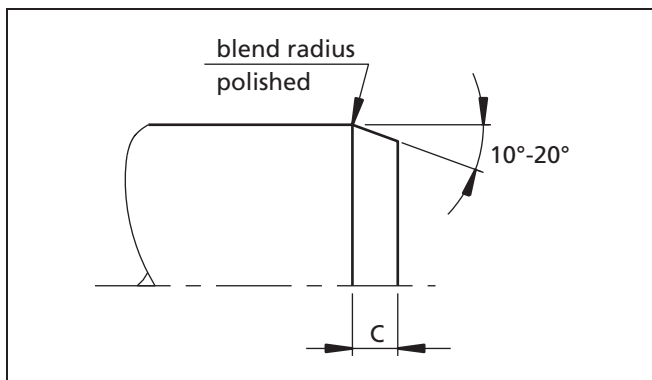

Figure 128 Lead-in chamfer on shaft

Table LXXXI Lead-in chamfers for Zurcon® Roto Glyd Ring® S

Series no.		Lead-in chamfers length C min.
Shaft	Bore	
TG50	TG60	2.0
TG51	TG61	2.5
TG52	TG62	3.5
TG53	TG63	5.0
TG54	TG64	6.5
TG55	TG65	7.5

Table LXXXII Surface roughness

Parameter	Surface roughness μm	
	Mating surface	
	Zurcon® materials	Groove surface
R_{max}	0.63 - 2.50	< 16.0
R_z DIN	0.40 - 1.60	< 10.0
R_a	0.05 - 0.20	< 1.6

The material contact area R_{mr} should be approx. 50 to 70%, determined at a cut depth $c = 0.25 \times R_z$, relative to a reference line of C_{ref} . 5%.

For ceramic coated surfaces, like plasma sprayed, additional focus on surface texture is necessary. Peaks and sharp edges from pores have to be polished away (e.g. with diamond paste on soft "pad") to avoid premature seal wear.

Closed grooves

Zurcon® Roto Glyd Ring® S for shaft and bore sealing can be installed in closed grooves at diameters from $\varnothing 12$. Seal cross sections used outside of their recommended diameter range require split grooves according to the table below.

Table LXXXIII Groove type - closed or split

Series no.		Split grooves required below		
Shaft	Bore	Zurcon® Z51	Zurcon® Z52	Zurcon® Z80
TG50	-	$\varnothing 18$	$\varnothing 12$	$\varnothing 18$
TG51	-	$\varnothing 25$	$\varnothing 19$	$\varnothing 25$
TG52	-	$\varnothing 33$	$\varnothing 33$	$\varnothing 33$
TG53	-	$\varnothing 60$	$\varnothing 60$	$\varnothing 60$
-	TG60	$\varnothing 25$	$\varnothing 12$	$\varnothing 25$
-	TG61	$\varnothing 38$	$\varnothing 25$	$\varnothing 38$
-	TG62	$\varnothing 50$	$\varnothing 32$	$\varnothing 50$
-	TG63	$\varnothing 75$	$\varnothing 50$	$\varnothing 75$



■ Installation of Zurcon[®] Roto Glyd Ring[®] S

Installation instructions

The following points should be observed before installation of the seals:

- Check whether housing or shaft has a lead-in chamfer; if not, use an installation sleeve
- Deburr and chamfer or round sharp edges, cover the tips of any screw threads
- Remove machining residues such as chips, dirt and other foreign particles and carefully clean all parts
- The seals can be installed more easily if they are greased or oiled. Attention must be paid to the compatibility of the seal materials with these lubricants. Use only grease without solid additives (e.g. molybdenum disulfide or zinc sulfide)
- Do not use installation tools with sharp edges

Installation of Zurcon[®] Roto Glyd Ring[®] S in split grooves

“shaft and bore sealing”

Installation in split grooves is simple. During final assembly - insertion of the shaft - the Zurcon[®] Roto Glyd Ring[®] S must be sized. The shaft itself can be used for this purpose, provided it has a long lead-in chamfer. Alternatively a corresponding mandrel can be used.

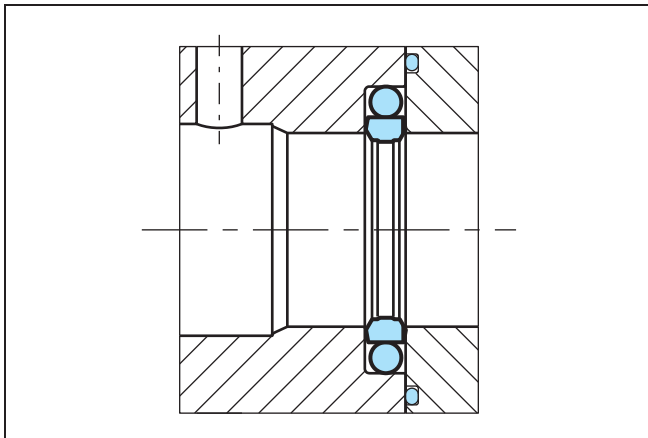

Figure 129 Installation in a split groove

The following installation sequence is recommended:

- Pull the O-Ring onto the Roto Glyd Ring[®] S
- Press the seal element into the groove. The O-Ring must not be allowed to twist

Installation of Zurcon[®] Roto Glyd Ring[®] S in closed grooves

“shaft sealing”

The installation of our seal elements is unproblematic.

- Place the O-Ring into the groove (avoid twisting the ring!)
- Compress the Zurcon[®] Roto Glyd Ring[®] S into a kidney shape. The seal must have no sharp bends

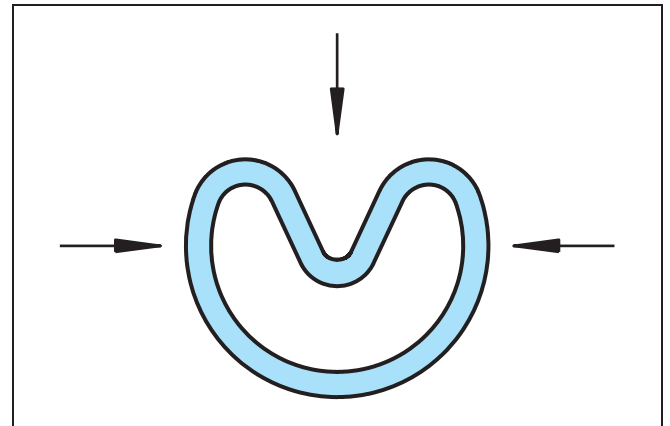

Figure 130 Kidney-shaped deformation of the seal ring

- Place the seal ring in compressed form into the groove and push against the O-Ring in the direction of the arrow.

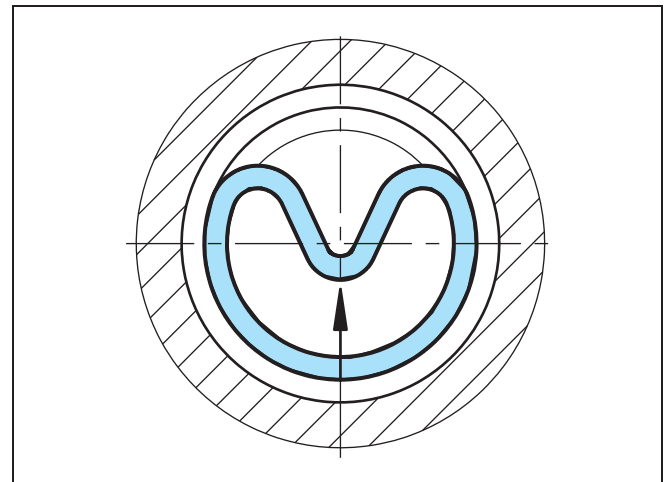

Figure 131 Inserting the seal ring into the closed groove

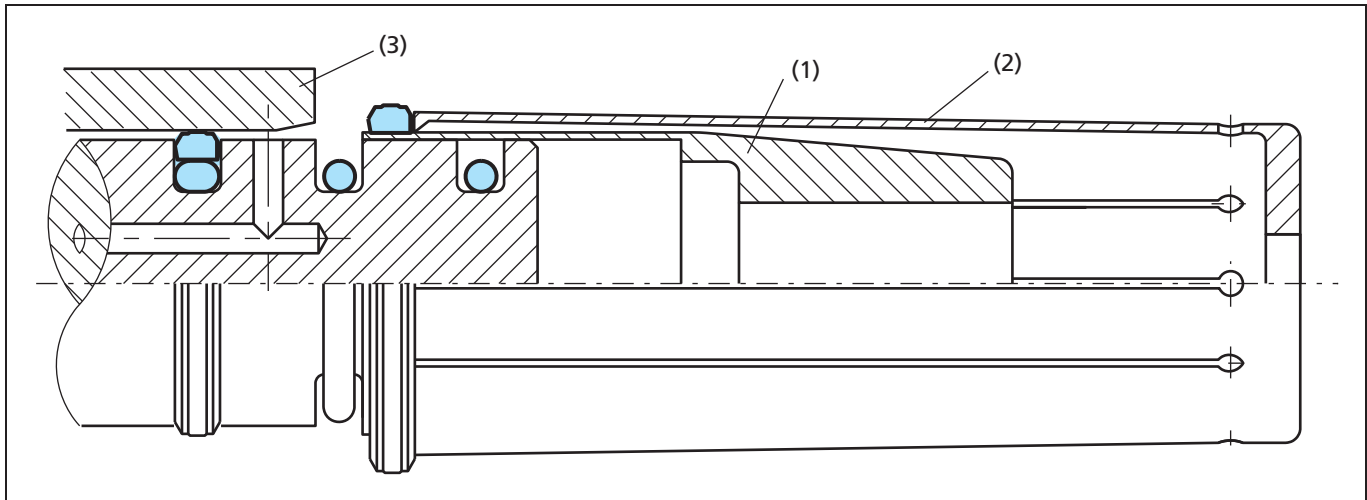

Figure 132 Expanding the Zurcon[®] Roto Glyd Ring[®] S over the installation sleeve using an expanding sleeve

Installation with installation tools (bore sealing)

Use of a three-piece installation tool is recommended for series production installation of the Zurcon[®] Roto Glyd Ring[®] S.

The tool consists of:

- Installation sleeve (1)
- Expanding sleeve (2)
- Sizing sleeve (3).

All parts should be made of a polymer material (e.g. polyamide) with a good surface finish to avoid damage to the seals.

The O-Ring should be pulled over the piston into the groove (take care not to burst the O-Ring).

The Roto Glyd Ring[®] S element should be expanded over the Installation sleeve using the Expanding sleeve with a fast but smooth movement.

If the cylinder bore has a sufficient lead-in chamfer, see Figure 127, it is in general possible to install Zurcon[®] Roto Glyd Ring[®] S in material Z51, Z52 and Z80 without using the Sizing sleeve shown in the figure above.

In view of the large number of sizes and the application-specific installation conditions, this installation tool cannot be supplied as standard by Trelleborg Sealing Solutions.

Drawings for installation tools are available on request.

Installation without installation tools (bore sealing)

If installation has to be performed without installation tools, however, the following points should be observed:

- The Roto Glyd Ring[®] S can be installed more easily by heating in oil or using a hot air fan to approx. 80°C
- Use no sharp edged tools to expand the seal rings
- Installation should be performed as quickly as possible so that an optimum snap-back of the seal element is assured



■ Installation recommendation - shaft sealing

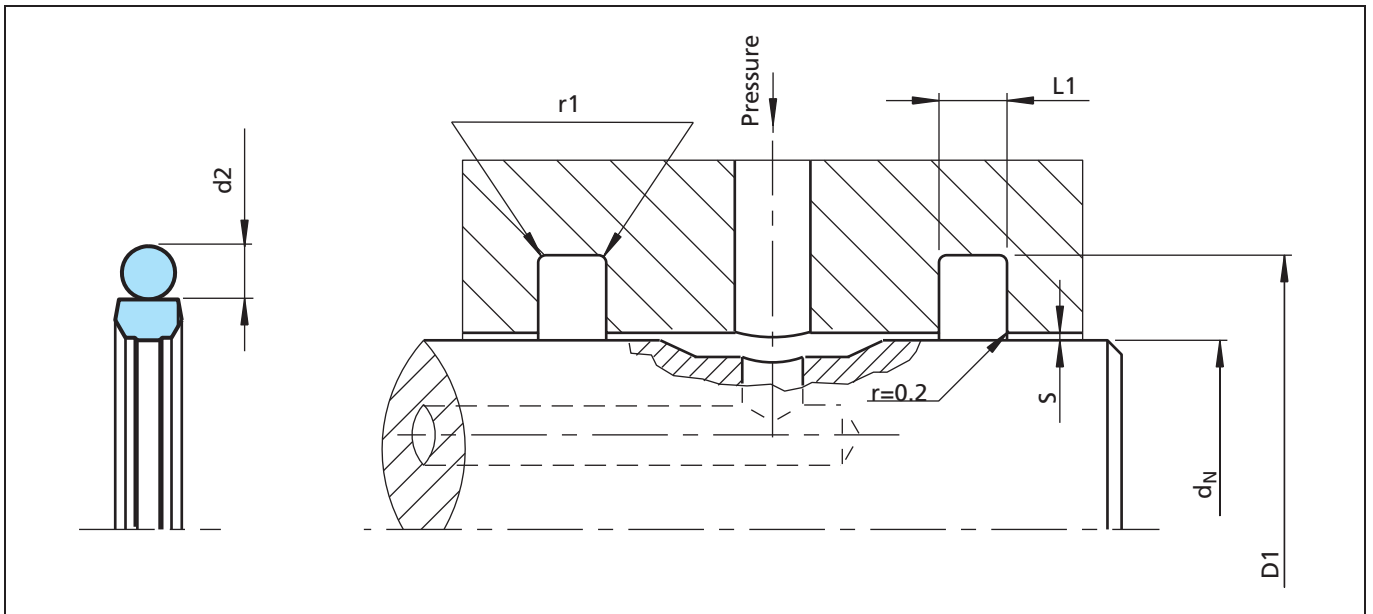

Figure 133 Installation drawing

Table LXXXIV Installation dimensions

Series No.	Shaft diameter d_N f8/h9		Groove diameter D_1 H9	Groove width $L_1 + 0.2$	Radial clearance S max*		Radius r_1	O-Ring cross sec. d_2
	Standard range	Available range			10 MPa	30 MPa		
TG50	12 - 18.9	10 - 18.9	$d_N + 4.9$	2.20	0.20	0.10	0.40	1.78
TG51	19 - 37.9	12 - 59.9	$d_N + 7.5$	3.20	0.25	0.15	0.60	2.62
TG52	38 - 132.9	19 - 199.9	$d_N + 11.0$	4.20	0.30	0.20	1.00	3.53
TG53	133 - 255.9	38 - 329.9	$d_N + 15.5$	6.30	0.35	0.25	1.30	5.33
TG54	256 - 649.9	120 - 655.0	$d_N + 21.0$	8.10	0.40	0.25	1.80	7.00
TG55	650 - 999.9	650 - 999.9	$d_N + 28.0$	9.50	0.50	0.30	2.50	8.40

* For max. temperature = 60° C at the seal.



Zurcon® Roto Glyd Ring® S

Zurcon® Roto Glyd Ring® S, complete with O-Ring, shaft sealing, series TG52.

Shaft diameter: $d_N = 80.0$ mm
 TSS Part No.: TG5200800

Select the material from Table LXXX. The corresponding code numbers are appended to the TSS Part No. Together they form the TSS Article No.

For all intermediate sizes not shown in Table LXXXV, the TSS Article No. can be determined from the example below.

** For diameters ≥ 1000.0 mm multiply only by factor 1.

Example: TG55 for diameter 1200.0 mm.

TSS Article No.: TG55**X1200** - Z52N.

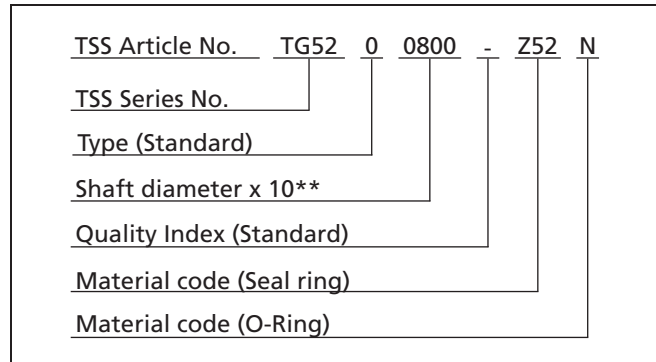

Table LXXXV Preferred dimensions / TSS Part No.

Shaft diameter	Groove diameter	Groove width	TSS Part No.	O-Ring size
d_N f8/h9	D_1 H9	L_1 +0.2		
10.0	14.9	2.2	TG5000100	11.80 x 1.80
12.0	16.9	2.2	TG5000120	14.00 x 1.78
14.0	18.9	2.2	TG5000140	15.60 x 1.78
15.0	19.9	2.2	TG5000150	17.17 x 1.78
16.0	20.9	2.2	TG5000160	18.77 x 1.78
16.0	23.5	3.2	TG5100160	18.72 x 2.62
18.0	22.9	2.2	TG5000180	20.35 x 1.78
18.0	25.5	3.2	TG5100180	21.89 x 2.62
20.0	27.5	3.2	TG5100200	23.47 x 2.62
22.0	29.5	3.2	TG5100220	25.07 x 2.62
25.0	32.5	3.2	TG5100250	28.24 x 2.62
28.0	35.5	3.2	TG5100280	31.42 x 2.62
30.0	37.5	3.2	TG5100300	32.99 x 2.62
32.0	39.5	3.2	TG5100320	34.59 x 2.62
32.0	43.0	4.2	TG5200320	36.09 x 3.53
35.0	42.5	3.2	TG5100350	37.77 x 2.62
36.0	43.5	3.2	TG5100360	37.77 x 2.62
36.0	47.0	4.2	TG5200360	40.87 x 3.53
38.0	49.0	4.2	TG5200380	44.04 x 3.53
40.0	51.0	4.2	TG5200400	47.22 x 3.53
42.0	53.0	4.2	TG5200420	47.22 x 3.53

The shaft diameters printed in **bold** type conform to the recommendations of ISO 3320.

Other dimensions and all intermediate sizes up to 2.200 mm diameter for Z51 and Z52 (2.600 mm for Z80) including inch sizes can be supplied.



Shaft diameter	Groove diameter	Groove width	TSS Part No.	O-Ring size
d_N f8/h9	D_1 H9	L_1 +0.2		
45.0	56.0	4.2	TG5200450	50.39 x 3.53
48.0	59.0	4.2	TG5200480	53.57 x 3.53
48.0	63.5	6.3	TG5300480	56.52 x 5.33
50.0	61.0	4.2	TG5200500	56.74 x 3.53
50.0	65.5	6.3	TG5300500	56.52 x 5.33
52.0	63.0	4.2	TG5200520	56.74 x 3.53
55.0	66.0	4.2	TG5200550	59.92 x 3.53
55.0	70.5	6.3	TG5300550	62.87 x 5.33
56.0	67.0	4.2	TG5200560	59.92 x 3.53
60.0	71.0	4.2	TG5200600	66.27 x 3.53
60.0	75.5	6.3	TG5300600	66.04 x 5.33
63.0	74.0	4.2	TG5200630	69.44 x 3.53
63.0	78.5	6.3	TG5300630	69.22 x 5.33
65.0	76.0	4.2	TG5200650	69.44 x 3.53
65.0	80.5	6.3	TG5300650	72.39 x 5.33
70.0	81.0	4.2	TG5200700	75.79 x 3.53
70.0	85.5	6.3	TG5300700	75.57 x 3.53
75.0	86.0	4.2	TG5200750	82.15 x 3.53
75.0	90.5	6.3	TG5300750	81.92 x 5.33
80.0	91.0	4.2	TG5200800	85.32 x 3.53
80.0	95.5	6.3	TG5300800	88.27 x 5.33
85.0	96.0	4.2	TG5200850	91.67 x 3.53
85.0	100.5	6.3	TG5300850	91.44 x 5.33
90.0	101.0	4.2	TG5200900	94.84 x 3.53
90.0	105.5	6.3	TG5300900	97.79 x 5.33
92.0	103.0	4.2	TG5200920	98.02 x 3.53
95.0	106.0	4.2	TG5200950	101.19 x 3.53
95.0	110.5	6.3	TG5300950	100.97 x 5.33
100.0	111.0	4.2	TG5201000	107.54 x 3.53
100.0	115.5	6.3	TG5301000	107.32 x 5.33
105.0	116.0	4.2	TG5201050	110.72 x 3.53
110.0	121.0	4.2	TG5201100	117.07 x 3.53
115.0	126.0	4.2	TG5201150	120.24 x 3.53

The shaft diameters printed in **bold** type conform to the recommendations of ISO 3320.

Other dimensions and all intermediate sizes up to 2.200 mm diameter for Z51 and Z52 (2.600 mm for Z80) including inch sizes can be supplied.



Zurcon[®] Roto Glyd Ring[®] S

Shaft diameter	Groove diameter	Groove width	TSS Part No.	O-Ring size
d_N f8/h9	D_1 H9	L_1 +0.2		
120.0	131.0	4.2	TG5201200	126.59 x 3.53
125.0	136.0	4.2	TG5201250	129.77 x 3.53
130.0	141.0	4.2	TG5201300	136.12 x 3.53
130.0	145.5	6.3	TG5301300	139.07 x 5.33
135.0	150.5	6.3	TG5301350	142.24 x 5.33
138.0	153.5	6.3	TG5301380	145.42 x 5.33
140.0	155.5	6.3	TG5301400	148.59 x 5.33
145.0	160.5	6.3	TG5301450	151.77 x 5.33
150.0	165.5	6.3	TG5301500	158.12 x 5.33
160.0	175.5	6.3	TG5301600	170.82 x 5.33
170.0	185.5	6.3	TG5301700	177.17 x 5.33
180.0	195.5	6.3	TG5301800	189.87 x 5.33
190.0	205.5	6.3	TG5301900	202.57 x 5.33
200.0	215.5	6.3	TG5302000	208.92 x 5.33
210.0	225.5	6.3	TG5302100	221.62 x 5.33
220.0	235.5	6.3	TG5302200	227.97 x 5.33
240.0	255.5	6.3	TG5302400	247.02 x 5.33
250.0	265.5	6.3	TG5302500	258.00 x 5.30
280.0	301.0	8.1	TG5402800	291.47 x 7.00
300.0	321.0	8.1	TG5403000	310.00 x 7.00
320.0	341.0	8.1	TG5403200	329.57 x 7.00
350.0	371.0	8.1	TG5403500	365.00 x 7.00
360.0	381.0	8.1	TG5403600	375.00 x 7.00
400.0	421.0	8.1	TG5404000	412.00 x 7.00
420.0	441.0	8.1	TG5404200	430.66 x 7.00
450.0	471.0	8.1	TG5404500	462.00 x 7.00
480.0	501.0	8.1	TG5404800	494.16 x 7.00
500.0	521.0	8.1	TG5405000	515.00 x 7.00
600.0	621.0	8.1	TG5406000	615.00 x 7.00
700.0	728.0	9.5	TG5507000	713.00 x 8.40

The shaft diameters printed in **bold** type conform to the recommendations of ISO 3320.

Other dimensions and all intermediate sizes up to 2.200 mm diameter for Z51 and Z52 (2.600 mm for Z80) including inch sizes can be supplied.



■ Installation recommendation - bore sealing

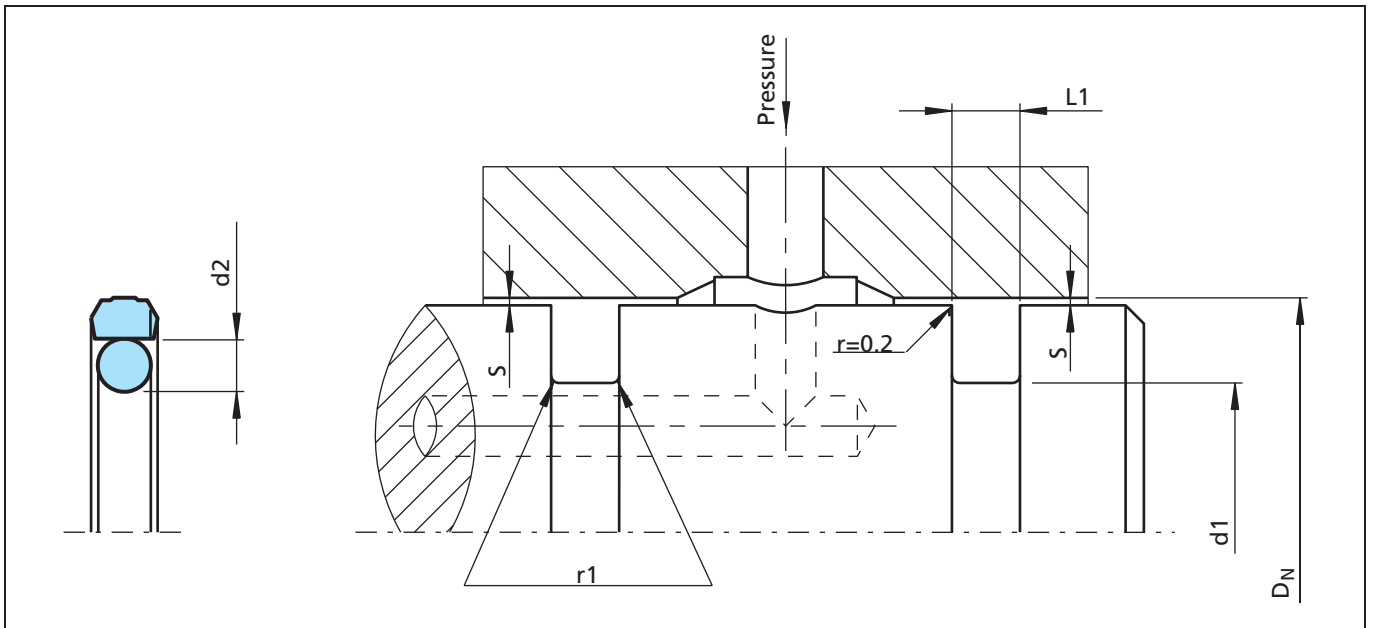

Figure 134 Installation drawing

Table LXXXVI Installation dimensions

Series No.	Bore diameter		Groove diameter	Groove width	Radial clearance S max*		Radius	O-Ring cross sec.
	D _N H9				10 MPa	30 MPa		
	Standard range	Available range						
TG60	12 - 19.9	10 - 24.9	D _N - 4.9	2.20	0.20	0.10	0.40	1.78
TG61	20 - 39.9	14 - 69.9	D _N - 7.5	3.20	0.25	0.15	0.60	2.62
TG62	40 - 132.9	22 - 199.9	D _N - 11.0	4.20	0.30	0.20	1.00	3.53
TG63	133 - 255.9	40 - 329.9	D _N - 15.5	6.30	0.35	0.25	1.30	5.33
TG64	256 - 669.9	133 - 690.0	D _N - 21.0	8.10	0.40	0.25	1.80	7.00
TG65	670 - 999.9	670 - 999.9	D _N - 28.0	9.50	0.50	0.30	2.50	8.40

* For max. temperature = 60° C at the seal.



Zurcon® Roto Glyd Ring® S

Zurcon® Roto Glyd Ring® S, complete with O-Ring, bore sealing, series TG62.

Bore diameter: $D_N = 80.0$ mm
 TSS Part No.: TG6200800

Select the material from Table LXXX. The corresponding code numbers are appended to the TSS Part No. (from Table LXXXVII. Together they form the TSS Article No. For all intermediate sizes not shown in Table LXXXVII, the TSS Article No. can be determined from the example opposite.

** For diameters ≥ 1000.0 mm multiply only by factor 1.

Example: TG65 for diameter 1200.0 mm.

TSS Article No.: TG65**X1200** - Z52N.

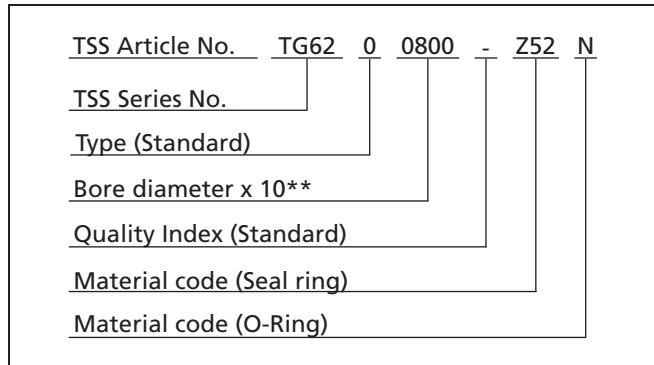

Table LXXXVII Installation Dimensions / TSS Part No.

Bore diameter	Groove diameter	Groove width	TSS Part No.	O-Ring size
D_N H9	d_1 h9	L_1 +0.2		
12.0	7.1	2.2	TG6000120	7.65 x 1.78
14.0	9.1	2.2	TG6000140	9.25 x 1.78
15.0	10.1	2.2	TG6000150	10.82 x 1.78
16.0	11.1	2.2	TG6000160	10.82 x 1.78
18.0	13.1	2.2	TG6000180	13.20 x 1.80
20.0	12.5	3.2	TG6100200	12.37 x 2.62
22.0	14.5	3.2	TG6100220	13.94 x 2.62
25.0	17.5	3.2	TG6100250	17.12 x 2.62
28.0	20.5	3.2	TG6100280	20.29 x 2.62
30.0	22.5	3.2	TG6100300	23.47 x 2.62
32.0	24.5	3.2	TG6100320	25.07 x 2.62
35.0	27.5	3.2	TG6100350	28.24 x 2.62
40.0	29.0	4.2	TG6200400	29.74 x 3.53
42.0	31.0	4.2	TG6200420	31.32 x 3.53
45.0	34.0	4.2	TG6200450	34.52 x 3.53
48.0	37.0	4.2	TG6200480	37.69 x 3.53
50.0	39.0	4.2	TG6200500	40.87 x 3.53
52.0	41.0	4.2	TG6200520	42.00 x 3.50
55.0	44.0	4.2	TG6200550	44.04 x 3.53
60.0	49.0	4.2	TG6200600	50.39 x 3.53
63.0	52.0	4.2	TG6200630	53.34 x 3.53
65.0	49.5	6.3	TG6300650	50.17 x 5.33
70.0	59.0	4.2	TG6200700	59.92 x 3.53
75.0	64.0	4.2	TG6200750	65.00 x 3.50

The bore diameters printed in **bold** type conform to the recommendations of ISO 3320.

Other dimensions and all intermediate sizes up to 2.300 mm diameter for Z51 and Z52 (2.700 mm for Z80) including inch sizes can be supplied.



Bore diameter	Groove diameter	Groove width	TSS Part No.	O-Ring size
D_N H9	d_1 h9	L_1 +0.2		
80.0	64.5	6.3	TG6300800	66.04 x 5.33
80.0	69.0	4.2	TG6200800	69.44 x 3.53
84.0	73.0	4.2	TG6200840	72.62 x 3.53
85.0	74.0	4.2	TG6200850	75.79 x 3.53
90.0	79.0	4.2	TG6200900	78.97 x 3.53
95.0	84.0	4.2	TG6200950	85.32 x 3.53
100.0	89.0	4.2	TG6201000	91.67 x 3.53
105.0	94.0	4.2	TG6201050	94.84 x 3.53
110.0	99.0	4.2	TG6201100	101.19 x 3.53
115.0	104.0	4.2	TG6201150	104.37 x 3.53
120.0	109.0	4.2	TG6201200	110.72 x 3.53
125.0	114.0	4.2	TG6201250	113.89 x 3.53
130.0	119.0	4.2	TG6201300	120.24 x 3.53
135.0	119.5	6.3	TG6301350	120.02 x 5.33
140.0	124.5	6.3	TG6301400	126.37 x 5.33
150.0	134.5	6.3	TG6301500	135.89 x 5.33
150.0	139.0	4.2	TG6201500	139.29 x 3.53
160.0	144.5	6.3	TG6301600	145.42 x 5.33
170.0	154.5	6.3	TG6301700	158.12 x 5.33
180.0	164.5	6.3	TG6301800	164.47 x 5.33
190.0	174.5	6.3	TG6301900	177.17 x 5.33
200.0	184.5	6.3	TG6302000	189.87 x 5.33
210.0	194.5	6.3	TG6302100	196.22 x 5.33
220.0	204.5	6.3	TG6302200	208.92 x 5.33
230.0	214.5	6.3	TG6302300	215.27 x 5.33
240.0	224.5	6.3	TG6302400	227.92 x 5.33
250.0	234.5	6.3	TG6302500	240.67 x 5.33
280.0	259.0	8.1	TG6402800	260.00 x 7.00
300.0	279.0	8.1	TG6403000	280.00 x 7.00
320.0	299.0	8.1	TG6403200	300.00 x 7.00
350.0	329.0	8.1	TG643500	329.57 x 7.00
400.0	379.0	8.1	TG6404000	380.37 x 7.00
420.0	399.0	8.1	TG6404200	400.00 x 7.00

The bore diameters printed in **bold** type conform to the recommendations of ISO 3320.

Other dimensions and all intermediate sizes up to 2.300 mm diameter for Z51 and Z52 (2.700 mm for Z80) including inch sizes can be supplied.



Zurcon[®] Roto Glyd Ring[®] S

Bore diameter	Groove diameter	Groove width	TSS Part No.	O-Ring size
D_N H9	d₁ h9	L₁ +0.2		
450.0	429.0	8.1	TG6404500	430.66 x 7.00
480.0	459.0	8.1	TG6404800	462.00 x 7.00
500.0	479.0	8.1	TG6405000	481.38 x 7.00
600.0	579.0	8.1	TG6406000	582.68 x 7.00
700.0	672.0	9.5	TG6507000	670.00 x 8.40

The bore diameters printed in **bold** type conform to the recommendations of ISO 3320.
Other dimensions and all intermediate sizes up to 2.300 mm diameter for Z51 and Z52 (2.700 mm for Z80) including inch sizes can be supplied.

Turcon[®] Roto Variseal[®]







■ TURCON® ROTARY SEALS - SPRING ENERGIZED

■ Turcon® Roto Variseal®

Description

The Turcon® Roto Variseal® is a single-acting seal consisting of a U-shaped seal jacket and a V-shaped corrosion resistant metal spring.

The characteristic of the Roto Variseal® is the flanged heel, which prevents the seal from rotating by clamping in the groove and the short and heavy dynamic lip offering reduced friction, long service life and a good scraping effect even in highly viscous media.

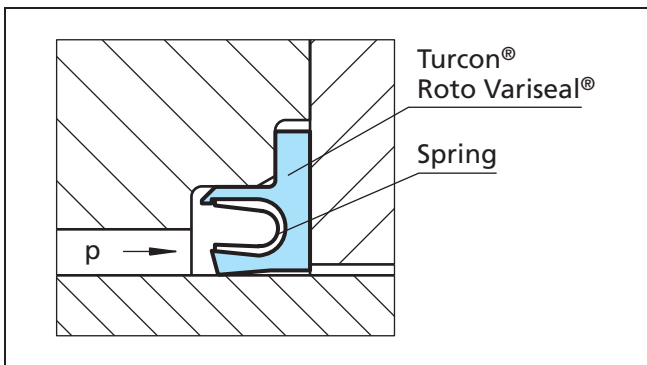

Figure 135 Turcon® Roto Variseal®

At low and zero pressure, the metal spring provides the primary sealing force. As the system pressure increases, the main sealing force is achieved by the system pressure and ensures a tight seal from zero to high pressure.

The possibility of matching suitable materials for the seal and the spring allows use in a wide range of applications going beyond the field of hydraulics, e.g. in the chemical, pharmaceutical and foodstuffs industry.

The Roto Variseal® can be sterilized and is available in a special Hi-Clean version where the spring cavity is filled with a Silicone elastomer preventing contaminants from being entrapped in the seal. This design also works well in applications involving mud, slurries or adhesives to keep grit from packing into the seal cavity and inhibiting the spring action.

Advantages

- Suitable for rotary, reciprocating and static applications
- Protects against mechanical torsion
- Low coefficient of friction
- Remains tight in groove even when subject to oscillating or helical movements
- Withstands rapid changes in temperature
- High abrasion resistance
- Excellent resistance to aging
- Good scraping ability
- Can be sterilized
- Available in Hi-Clean version

Technical data

Operating pressure:	For dynamic loads: 15 MPa For static loads: 25 MPa
Speed:	Rotating: Up to 2 m/s
Temperature:	-100 °C to +260 °C For specific applications at lower temperatures, please enquire
Media compatibility:	Virtually all fluids, chemicals and gases

Important Note:

The above data are maximum values and cannot be used at the same time, e. g. the maximum operating speed depends on material type, pressure and temperature.



Frictional force

Indicative values for frictional force are included in Figure 136. Frictional force is given as a function of sliding speed and operating pressure for a shaft diameter of 50 mm (2 inches) at an oil temperature of 60 °C. The operating limits are lower at higher temperatures.

Indicative values for other shaft diameters can be calculated from the formula:

$$P \approx P_{50} \times \left(\frac{d}{50 \text{ mm}}\right) \text{ [W]}$$

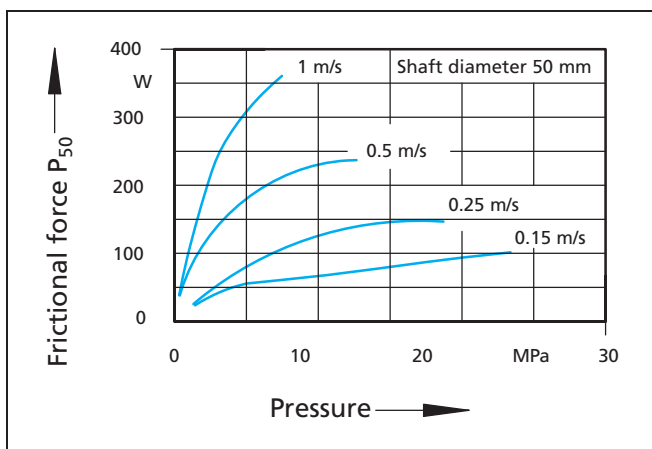

Figure 136 Frictional power for Turcon® Roto Variseal®

The indicative values apply for constant operating conditions. Changes in these, such as pressure fluctuations or direction of rotation can result in significantly higher frictional values.

Application examples

The Turcon® Roto Variseal® is used as a single acting rotary seal in sectors such as:

- Rotary injection units (injection molding machines)
- Rotary distributors
- Pivoting motors in pharmacy, industry, machine tools, foodstuff and chemical

Application limits

The maximum operating limits for temperature, pressure and speed are dependent upon one another and therefore cannot all apply at the same time.

The lubrication properties of the media to be sealed and heat dissipation must also be taken into consideration.

The following pv values can be used as general guidelines:

- Poor lubrication up to pv = 2 MPa x m/s
- Good lubrication up to pv = 5 MPa x m/s
- Very good cooling up to pv = 8 MPa x m/s

These values are lower for diameters < 50 mm (2 inches). Tests of these characteristics are recommended to establish application limits.

Materials

All materials used are physiologically safe. They contain no odour or taste-affecting substances. The following standard material combination has proved effective for most applications:

- Seal ring: Turcon® T40
- Spring: Stainless Steel Material No. AISI 301

For use in accordance with the demands of the "Food and Drug Administration", suitable materials are available on request.

Lead-in chamfers

In order to avoid damage during installation, lead-in chamfers and rounded edges must be provided on the housing and on the rod (Figure 137). If this is not possible for design reasons, a separate installation tool is recommended.

The minimum length of the lead-in chamfer depends on the profile size of the seal and can be seen from the following tables. If concentricity between the parts is not ensured during installation the lead-in chamfers must be increased correspondingly.

For the surface quality of the lead-in chamfer, the same recommendations apply as given for the sealing surfaces in Table XC.

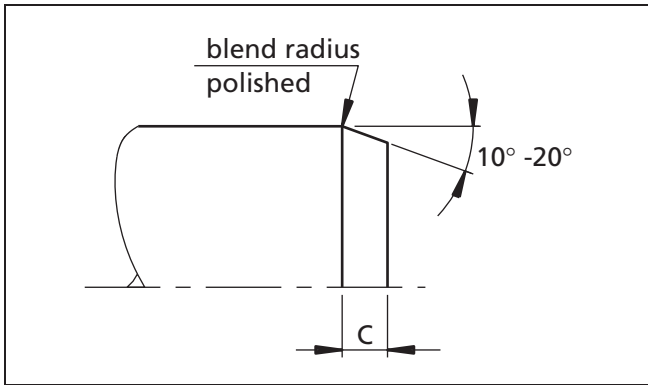

Figure 137 Lead-in chamfer on shaft

Table LXXXVIII Lead-in chamfers for Turcon® Roto Variseal®

Series	Lead-in Chamfers Length C min.
TVM1	4.5
TVM2	5.0
TVM3	8.0
TVM4	12.0

Mating surface materials

Sealing of applications with rotating movements require very good mating surfaces. A minimum hardness 55 HRC is recommended to a harding depth of at least 0.3 mm.

Particular attention must be paid to coated surfaces and good heat dissipation through the coating is required.

Shaft bearing/Radial clearance for bearing

In general the sealing elements should not take on any bearing tasks as this will reduce the functioning of the seals. Consequently we recommend to guide the components by means of a roller or slide bearing.

■ Installation of Turcon® Roto Variseal®

Installation instructions

The following points should be observed before installation of the seals:

- Check whether housing or rod has a lead-in chamfer; if not, use an installation sleeve
- Deburr and chamfer or round sharp edges, cover the tips of any screw threads
- Remove machining residues such as chips, dirt and other foreign particles and carefully clean all parts
- If the seals are installed with grease or oil, attention must be paid to the compatibility of the seal materials with these lubricants. Use only grease without solid additives (e.g. molybdenum disulfide or zinc sulfide)
- Do not use installation tools with sharp edges

Installation of Turcon® Roto Variseal®

Turcon® Roto Variseal® is installed in split grooves.

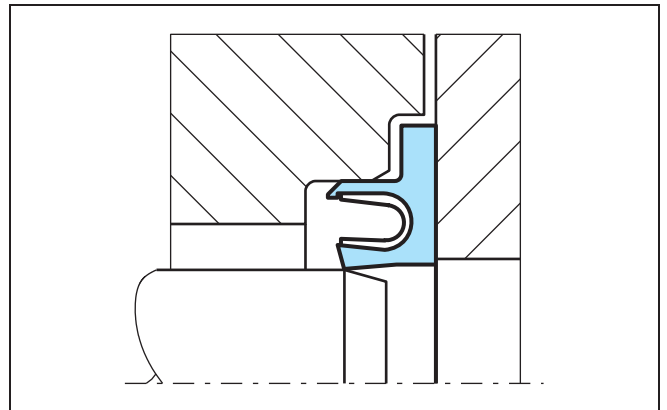

Figure 138 Turcon® Roto Variseal®

Installation should be performed in the following steps in order to ensure a concentric and strain-free fit:

- Place the seal ring in into the open groove
- Fit the cover loosely onto the housing
- Insert the shaft
- Tighten the cover



Table LXXXIX Standard Turcon® materials for Roto Variseal®

Material, Applications, Properties	Code	Spring material	Code	Operating temp. °C	Mating surface material	MPa max.
Turcon® T40 For all lubricating and non-lubricating hydraulic fluids, water hydraulics, soft mating surfaces Carbon fiber filled Color: Grey	T40	Spring material AISI 301	S	-100 to +260	Steel Steel, chrome plated Cast iron Stainless steel, Aluminum Bronze Alloys	15
Turcon® T78 For all lubricated and non-lubricated applications, soft mating surfaces. Aromatic polymer Color: Tan to dark brown	T78	Spring material AISI 301	S	-100 to +260	Steel Steel, chrome plated Cast iron Stainless steel	5

Highlighted materials are standard.

Trelleborg Sealing Solutions recommends that the following surface finishes be observed :

Table XC Surface roughness

Recommended maximum surface roughness μm		
Media	Shaft surface ¹⁾	Static groove surface
Cryogenic and low molecular gases Hydrogen, Helium, Freon, Oxygen Nitrogen	$R_{\text{max}} = 1.0 \mu\text{m}$ $R_z = 0.63 \mu\text{m}$ $R_a = 0.1 \mu\text{m}$	$R_{\text{max}} = 3.5 \mu\text{m}$ $R_z = 2.2 \mu\text{m}$ $R_a = 0.3 \mu\text{m}$
Low viscosity fluids Water, Alcohols, Hydrazine, Gaseous nitrogen, Natural gas, Skydrol, air	$R_{\text{max}} = 2.5 \mu\text{m}$ $R_z = 1.6 \mu\text{m}$ $R_a = 0.2 \mu\text{m}$	$R_{\text{max}} = 5.0 \mu\text{m}$ $R_z = 3.5 \mu\text{m}$ $R_a = 0.6 \mu\text{m}$
High viscosity fluids Hydraulic oils, Crude oil, Gear oil, Sealants, Glue, Milk products	$R_{\text{max}} = 2.5 \mu\text{m}$ $R_z = 1.6 \mu\text{m}$ $R_a = 0.2 \mu\text{m}$	$R_{\text{max}} = 6.5 \mu\text{m}$ $R_z = 5.0 \mu\text{m}$ $R_a = 0.8 \mu\text{m}$

¹⁾ The sealing surface must be free from spiral grooves.
The material contact area R_{mr} should be approx. 50 to 70%, determined at a cut depth $c = 0.25 \times R_z$, relative to a reference line of C_{ref} . 5%.



■ Installation recommendation

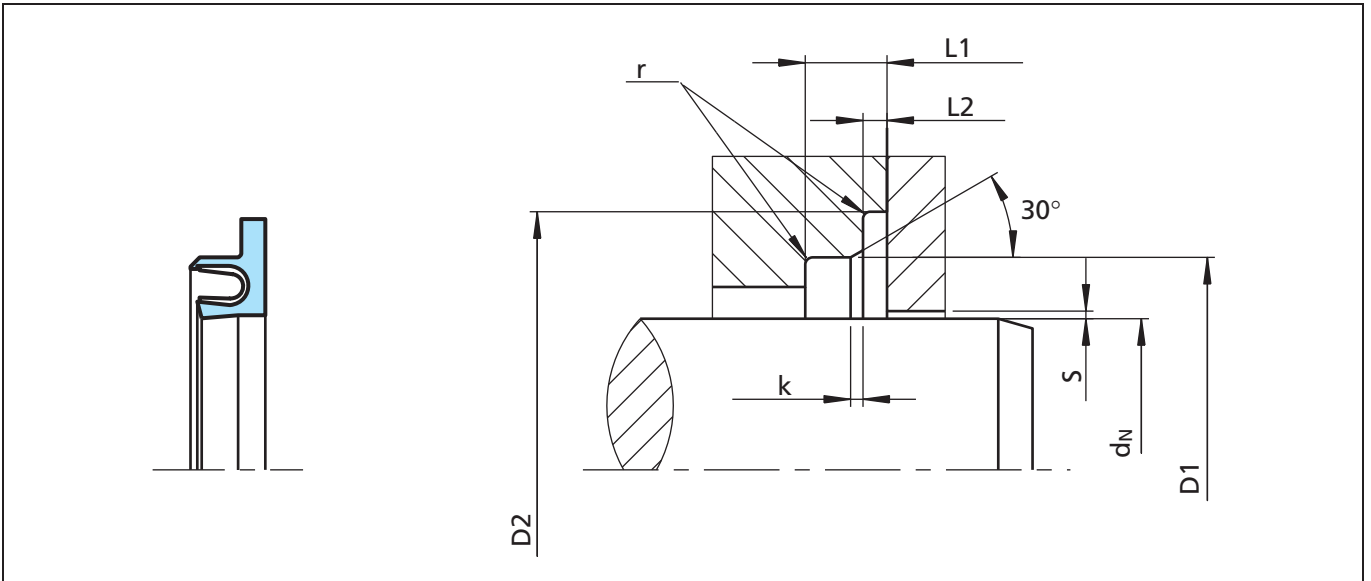

Figure 139 Installation drawing

Table XCI Installation dimensions

Series no.	Rod diameter		Groove diameter		Groove width		Lead-in chamfer	Ra- dius	Radial clearance S max.		
	Standard range d_N f8/h9	Available ¹⁾ range d_N f8/h9	D_1 H9	D_2 H10	L_1 min	L_2			k	r	< 2 MPa
TVM1	5.0 - 19.9	20.0 - 200.0	$d + 5.0$	$d + 9.0$	3.6	$0.85_{+0} / ^{-0.1}$	0.8	0.3	0.25	0.15	0.10
TVM2	20.0 - 39.9	10.0 - 400.0	$d + 7.0$	$d + 12.5$	4.8	$1.35_{+0} / ^{-0.15}$	1.1	0.4	0.35	0.20	0.15
TVM3	40.0 - 399.9	20.0 - 700.0	$d + 10.5$	$d + 17.5$	7.1	$1.80_{+0} / ^{-0.20}$	1.4	0.5	0.50	0.25	0.20
TCM4	400.0 - 999.9	35.0 - 999.9	$d + 14.0$	$d + 22.0$	9.5	$2.80_{+0} / ^{-0.20}$	1.6	0.5	0.60	0.30	0.25

¹⁾ Available on request. Application of a seal series outside of the standard range can impair seal performance and stability and should only be made after careful testing and evaluation.



Ordering example

Turcon® Roto Variseal®, series TVM3 (from Table XCI).

Rod diameter: $d_N = 80.0$ mm

TSS Part No.: TVM300800 (from Table XCII)

Select the material from Table LXXXIX. The corresponding code numbers are appended to the TSS Part No. (from Table XCII). Together they form the TSS Article No. For all intermediate sizes not shown in Table XCI, the TSS Article No. can be determined from the example opposite.

* For diameters ≥ 1000.0 mm multiply only by factor 1.
Example: TVM4 for diameter 1200.0 mm.

TSS Article No.: TVM4X1200 - T40S.

** Roto Variseal® are available with the spring groove filled with high temperature silicone. The silicone prevents entrapment of biological contaminants in the seal making the seal easier to clean.

TSS Article No.	TVM3	0	0800	-	T40	S	(D)
TSS Series No.							
Type (Standard)							
Rod Diameter x 10*							
Quality Index (Standard)							
Material code - Seal ring							
Material code - Spring							
Hi-Clean** - (option)							

Table XCII Preferred dimension / TSS Part No.

Rod diameter d_N f8/h9	Groove diameter		Groove width L_1	TSS Part No.
	D_1 H9	D_2 H10		
5.0	10.0	14.0	3.6	TVM100050
6.0	11.0	15.0	3.6	TVM100060
8.0	13.0	17.0	3.6	TVM100080
10.0	15.0	19.0	3.6	TVM100100
12.0	17.0	21.0	3.6	TVM100120
14.0	19.0	23.0	3.6	TVM100140
15.0	20.0	24.0	3.6	TVM100150
16.0	21.0	25.0	3.6	TVM100160
18.0	23.0	27.0	3.6	TVM100180
20.0	27.0	32.5	4.8	TVM200200
22.0	29.0	34.5	4.8	TVM200220
25.0	32.0	37.5	4.8	TVM200250
28.0	35.0	40.5	4.8	TVM200280
30.0	37.0	42.5	4.8	TVM200300
32.0	39.0	44.5	4.8	TVM200320
35.0	42.0	47.5	4.8	TVM200350
36.0	43.0	48.5	4.8	TVM200360
40.0	50.5	57.5	7.1	TVM300400
42.0	52.5	59.5	7.1	TVM300420
45.0	55.5	62.5	7.1	TVM300450
48.0	58.5	65.5	7.1	TVM300480
50.0	60.5	67.5	7.1	TVM300500
52.0	62.5	69.5	7.1	TVM300520
55.0	65.5	72.5	7.1	TVM300550

Rod diameter d_N f8/h9	Groove diameter		Groove width L_1	TSS Part No.
	D_1 H9	D_2 H10		
56.0	66.5	73.5	7.1	TVM300560
60.0	70.5	77.5	7.1	TVM300600
63.0	73.5	80.5	7.1	TVM300630
65.0	75.5	82.5	7.1	TVM300650
70.0	80.5	87.5	7.1	TVM300700
75.0	85.5	92.5	7.1	TVM300750
80.0	90.5	97.5	7.1	TVM300800
85.0	95.5	102.5	7.1	TVM300850
90.0	100.5	107.5	7.1	TVM300900
95.0	105.5	112.5	7.1	TVM300950
100.0	110.5	117.5	7.1	TVM301000
105.0	115.5	122.5	7.1	TVM301050
110.0	120.5	127.5	7.1	TVM301100
115.0	125.5	132.5	7.1	TVM301150
120.0	130.5	137.5	7.1	TVM301200
125.0	135.5	142.5	7.1	TVM301250
130.0	140.5	147.5	7.1	TVM301300
135.0	145.5	152.5	7.1	TVM301350
140.0	150.5	157.5	7.1	TVM301400
150.0	160.5	167.5	7.1	TVM301500
160.0	170.5	177.5	7.1	TVM301600
170.0	180.5	187.5	7.1	TVM301700
180.0	190.5	197.5	7.1	TVM301800
190.0	200.5	207.5	7.1	TVM301900



Rod diameter	Groove diameter		Groove width	TSS Part No.
	d_N f8/h9	D_1 H9		
200.0	210.5	217.5	7.1	TVM302000
210.0	220.5	227.5	7.1	TVM302100
220.0	230.5	237.5	7.1	TVM302200
230.0	240.5	247.5	7.1	TVM302300
240.0	250.5	257.5	7.1	TVM302400
250.0	260.5	267.5	7.1	TVM302500
280.0	290.5	297.5	7.1	TVM302800
300.0	310.5	317.5	7.1	TVM303000
320.0	330.5	337.5	7.1	TVM303200
350.0	360.5	367.5	7.1	TVM303500
360.0	370.5	377.5	7.1	TVM303600
420.0	434.0	442.0	9.5	TVM404200
450.0	464.0	472.0	9.5	TVM404500
480.0	494.0	502.0	9.5	TVM404800
500.0	514.0	522.0	9.5	TVM405000
600.0	614.0	622.0	9.5	TVM406000
700.0	714.0	722.0	9.5	TVM407000

The rod diameters printed in **bold** type conform to the recommendations of ISO 3320.

Other dimensions and all intermediate sizes up to 2500 mm diameter including inch sizes can be supplied.



Mechanical Face Seals







■ Mechanical Face Seals

■ Description

Mechanical Face Seals are a special form of mechanical seals. They are also known under other designations, such as lifetime seals, floating seals, duo cone seals, toric seals and heavy duty seals.

Types

There are two different types of Mechanical Face Seals: the most common form is Type DO, which is characterized by the use of an O-Ring as the secondary sealing element (Figure 140).

Type DF, on the other hand, has an elastomer with a diamond-shaped cross section as a secondary sealing element instead of the O-Ring (Figure 141).

Both types consist of two identical metal seal rings which seal against each other on a lapped seal face.

Special designs, like that in Figure 142, are available on request. Seal types can also be divided by the use of different seal materials (see page 289).

Design Features

The seals consist of two metallic seal rings. They are mounted in separate housing face to face. The elastomeric elements center the seal in the housing.

There are two tapered cones in the housing and at the O.D. of the seal. The taper increases with the depth of the bore due to the different grade of the cones. The housing shape can normally be machined on a NC machine tool.

Method of Operation

The O-Ring and the elastomeric washer provide three different functions:

- They generate a uniform axial face load because of their elasticity.
- They act as a static seal at the inner diameter and outer diameter.
- They prevent the seal ring from turning with the shaft and transmit the torque from the rotating half of the housing through the faces to the static half.

It is important to know that only one half of the seal rotates; the interface between the two precision lapped mating surfaces rotating against the other at right angles to the shaft. They form a leak-proof seal.

The seal has a wedge shaped gap from the ID to the seal face allowing for easy access to lubricate the seal face. Lubrication is necessary at all times. The lubricant builds a thin film between the sliding faces by a capillary effect and centrifugal force.

The seal face is processed by grinding and lapping.

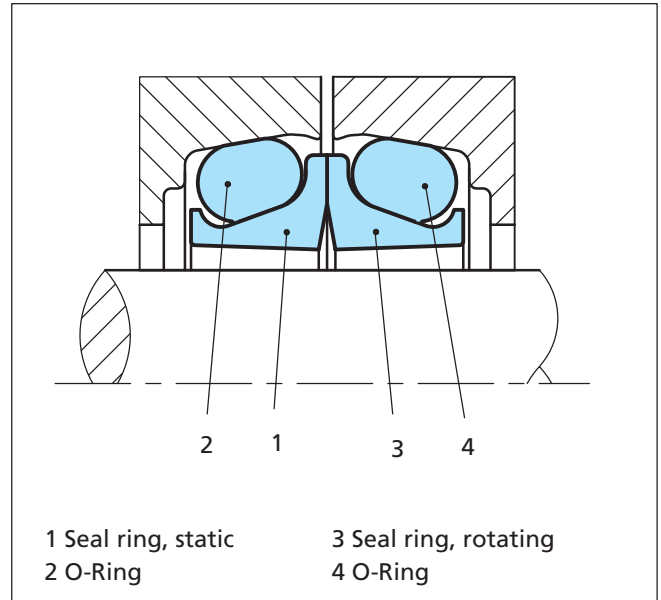

Figure 140 Mechanical Face Seals, Type DO

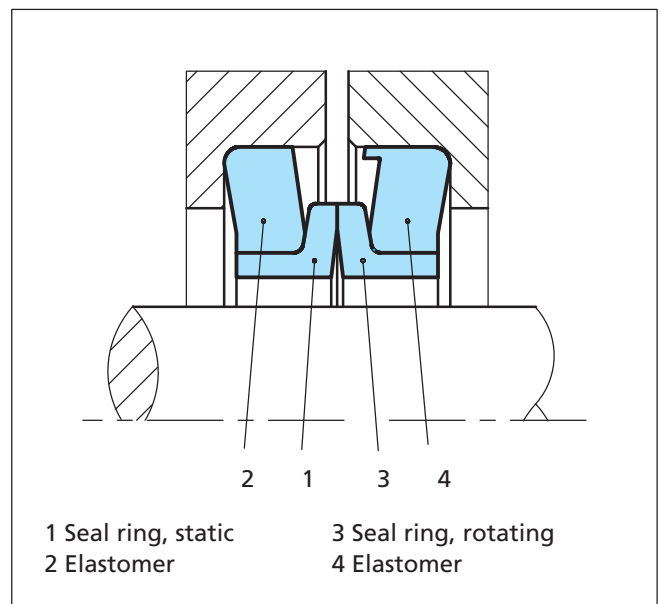

Figure 141 Mechanical Face Seals, Type DF



Mechanical Face Seals

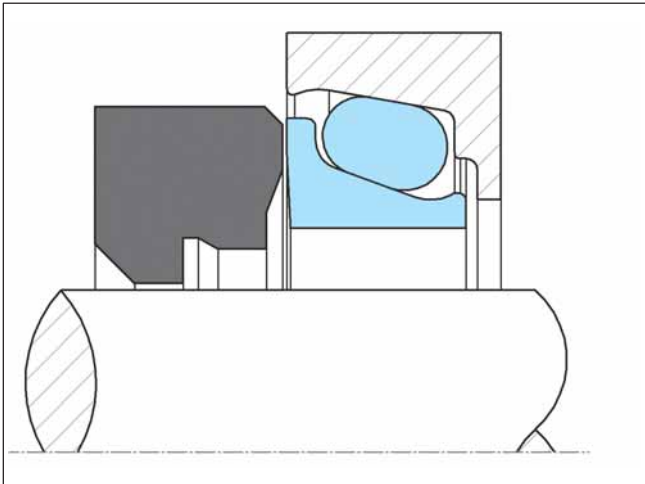

Figure 142 Special Design

Advantages:

- Simple, reliable design
- High sealing effect against dirt, dust, water and abrasive media from the outside and against oil and grease from the inside
- Cost-effective
- Long service life
- Self-centering to compensate for shaft eccentricity or misalignment
- Maintenance-free
- Easy to assemble

Applications

Mechanical Face Seals are predominantly used for sealing the bearings in construction machinery or production plants operating under extreme arduous conditions and subject to severe wear.

These include:

- Tracked vehicles, such as excavators and bulldozers
- Conveyor systems
- Heavy trucks
- Axles
- Tunnel boring machines
- Agriculture machines
- Mining machines

Mechanical Face Seals are proven in general machine engineering for gearboxes, mixers, stirrers, wind-driven power stations and other applications with similar conditions or where maintenance-free lifetime time sealing is expected.

Technical Data

The seals should not be subjected simultaneously to maximum pressure and maximum speed.

Operating Pressure:

The shaft seal is pressure-free under normal operating conditions.

Pressure loading up to max. 0.3 MPa (3 bar) for shell mold Cast Iron and 0.15 MPa (1.5 bar) for material 100Cr6 accepted. A higher static load up to 0.5 MPa (5 bar) is possible.

Internal pressure can lead to misalignment either of the seal or of the O-Ring.

Speed:

Cast Iron: 3 m/s with oil lubrication
100Cr6 2.2 m/s with oil lubrication

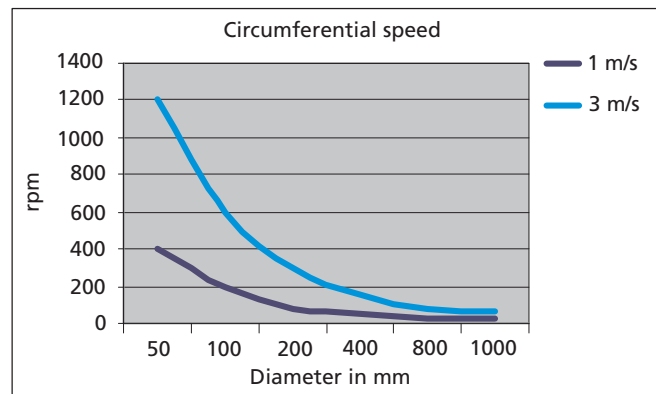

Figure 143 Speed as function of diameter and rpm

Temperature:

-40 °C to +200 °C (-40 °F to +392 °F), depending on the elastomer material.

Lubrication, Media:

The lubrication serves two important functions, therefore it is needed in all cases. It reduces the friction between the seal face and the mating faces, and it acts as a cooling agent for the complete shaft and housing.

The best results with regard to wear and service life are achieved with oil lubrication. Grease lubrication is possible but needs special attention. It can only be used for slower motion. It is sufficient if the oil level is 1/2 to 1/3 of the seal inside diameter. Specially recommended is transmission oil e.g. SAE 80 or SAE 90. In other cases a thinner lubricant can be useful like SAE oils 20W20 or 10W40. The oil level should be between the center line of the shaft and two thirds of seal diameter.

If environmentally compatible bio-oils are to be used, please contact us. In this case, the compatibility of the oil with the elastomer materials used must be tested.



Materials

Metal Parts

Mechanical Face Seals are available in two different steel grades.

The standard material used for the Mechanical Face Seals is a special shell mold Cast Iron. This material was developed specifically for the extreme operating conditions of the seals. The material is a high-alloy, corrosion-resistant Cast Iron. A natural hardness of 58 HRC is achieved directly after casting, which is increased to a minimum of 65 HRC by heat treatment.

The castings are then further processed by grinding, lapping and polishing. For material specifications, see Table XCIII.

Alternatively a cost-effective forged roller Bearing Steel (100CR6), material number 1.3505, can also be used. Seals made from this material are manufactured by copy turning followed by induction or salt bath hardening. The hardness is 58 to 63 HRC. The seal faces of these parts are also lapped and polished. For material specifications, see Table XCIII.

Table XCIII Preferred Materials

Material Chemical Composition %	Material No. 1.3505	Shell Mold Cast Iron
C	0.90 - 1.05	2.80 - 3.60
Si	0.15 - 0.35	1.00 - 1.60
Mn	0.25 - 0.45	0.40 - 1.00
P	< 0.03	< 0.04
S	< 0.025	< 0.04
Cr	1.40 - 1.65	16.00 - 19.00
Mo	—	2.00 - 4.00
Ni	< 0.30	—
Fe	balance	balance

Elastomers

Depending on seal type the following standard elastomers are used:

- Type DO - alloy Cast Iron
Acrylonitrile Butadiene Rubber (NBR)
- Type DO - Bearing Steel (1.3505)
Acrylonitrile Butadiene Rubber (NBR)

For higher thermal loads or other parameters, different compounds can be supplied.

Table XCIV Alternative Compounds

Compound	Hardness	Temperature range
HNBR	60-65 Shore A	-30 °C to 150 °C
FKM	60-65 Shore A	-20 °C to 200 °C
VQM	60-65 Shore A	-50 °C to 200 °C

Please contact your local Trelleborg Sealing Solutions marketing company.

Table XCV NBR Compounds

Seal Type	Standard NBR Compounds	
	Alloy Cast Iron seal	Bearing Steel Seals
Description	NBR	NBR
Hardness	60-65 Shore A	60-65 Shore A
Tensile strength	>12.0	>12.0
Elongation at break	>250	>280
Temperature range*	-30 °C to +100 °C (-22 °F to +212 °F)	-20 °C to +100 °C (-4 °F to +212 °F)

Corrosion Test

During operation, Mechanical Face Seals can be exposed not only to physical and thermal stresses, but also to extreme environmental stresses.

The behavior and resistance of the material to corrosion is a very important factor; e.g., in contact with seawater or in a maritime climate, when operating in salt plains or on exposure to salt spread on the roads in the winter. Mechanical Face Seals must also be able to withstand such conditions. The high-alloy shell mold cast material is particularly suitable to these environments. Trelleborg Sealing Solutions has demonstrated this under tough test conditions in salt water.

The surface of seals Bearing Steel 100Cr6 is not as resistant as the alloy materials even if with additional surface treatment a moderate corrosion resistance improvement is achieved.



■ Design Instructions

Seal Housing

The installation dimensions of the seal housing are shown in Table XCVI and XCVII.

A template can be used to check the housing geometry for Type DO.

The axial gap S in the housing is such that it meets the demands of the construction machinery industry.

For high sliding speeds it may be necessary to reduce the axial compression, thus reducing the load of the seal faces and the heat generation in the seal face. This is achieved by increasing the axial gap S .

The following gaps are possible (Table LXXXV), depending on the O-Ring cross section.

Table XCVI Gaps

O-Ring Cross-Section d_1	Gap S_{max}
$d_1 < 8.0$	4
$8 \leq d_1 \leq 12.7$	5
$d_1 > 12.7$	6

We recommend that tests be carried out to find the most appropriate setting.

Since the O-Ring is always oversized to the housing, the edges of the housing must be rounded.

Surfaces

Under pressure, elastomers adapt themselves to irregular surfaces. However, for liquid-tight conditions, certain minimum requirements have to be made on the surface finish of the faces to be sealed.

Scores, scratches, pores and concentric or spiral machining scores are not permissible. For the surface of the seal installation chamber we recommend a machining quality of:

R_a	< 3.2 μm
R_z	< 10.0 μm
R_{max}	< 16.0 μm .

Shaft

The Mechanical Face Seal does not contact the shaft. For this reason, no particular demands have to be met on the hardness or surface finish.

To ensure correct operation a minimum gap must be maintained between the shaft and the inside diameter. This gap serves to supply the seal with lubricant. In order to dissipate the heat of friction, a good exchange of medium must be assured. Furthermore, tolerances, shaft deflections, etc. must be bridged by the gap.

Attention should be paid to the slight geometric deviation between the forged and the cast design. Figure 144 shows a bevel on the cast seal ring typical of the casting process. The forged version, on the other hand, has a cylindrical inner diameter (Figure 145).

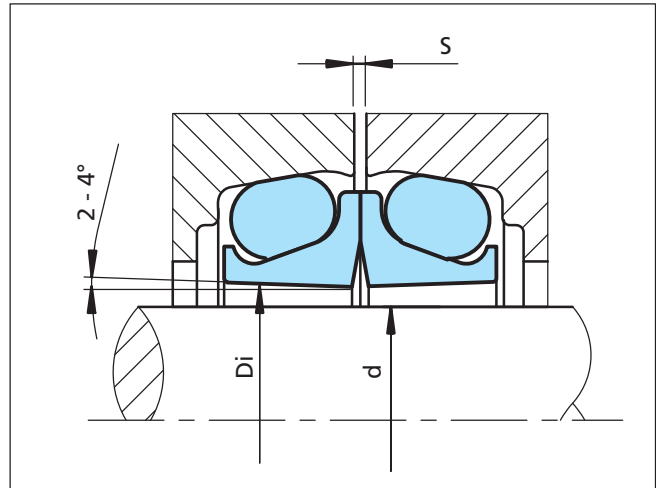

Figure 144 Cast design with inclination at the inside diameter

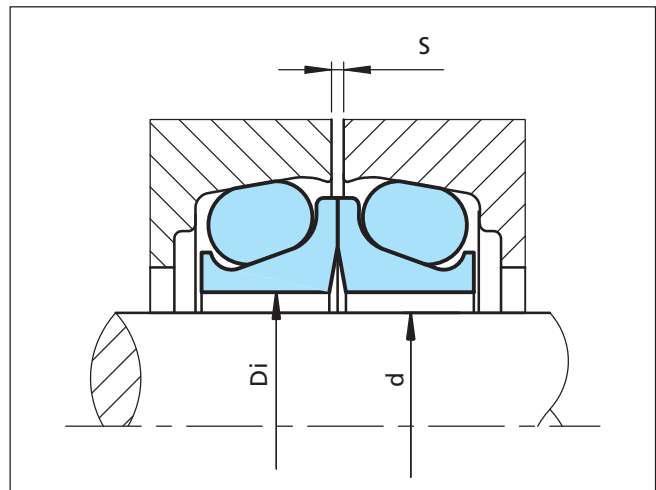

Figure 145 Roller Bearing Steel design with smooth and cylindrical treatment at the inside diameter



■ Installation Instructions

Preparation for Installation

Mechanical Face Seal must be installed with great care. Damage to the precision lapped seal faces must be avoided at all costs. The installation location must be kept free from dust and dirt.

The installation should be carried out in the following steps.

Preparation before Installation

- Remove the seal from its packing only immediately before installation.
- Do not stand the seal on the lapped surface.
- Coat the seal face with a thin film of oil using clean oil and a lint-free cloth, e.g. chamois leather.
- Check that the housing is free of nick or burr on installation radii.
- Check if O-Ring or washer is properly placed back on the seal. The O-Ring must be seated in the outer radius (Type DO) inside the retaining lip.

Installation Instructions for the Type DO

- Make sure that the O-Ring is not twisted. A twisted O-Ring may cause a looped effect.
- Installation, particularly of large O-Rings, requires a great deal of force. We recommend that the O-Ring be coated with lubricant (soapy water, water/spirits mixture or an oil film) before installation.
- Assemble the two halves of the seal in the housing by using an installation tool. Center the O-Ring in the housing. Use two hands on the tool to press the seal into the housing with a firm push.
- Check if the tool is touching the housing all around the circumference.
- Remove the tool and make a visual check for position of O-Ring and seal. Make sure that everything is seated symmetrically.
- Clean both seal faces with denatured alcohol and apply a thin film of clean oil to the faces.
- Tilt the two parts together bringing the slide faces carefully into contact.
- Adjust the gap S.
- Fill the housing with oil and bleed, if necessary.

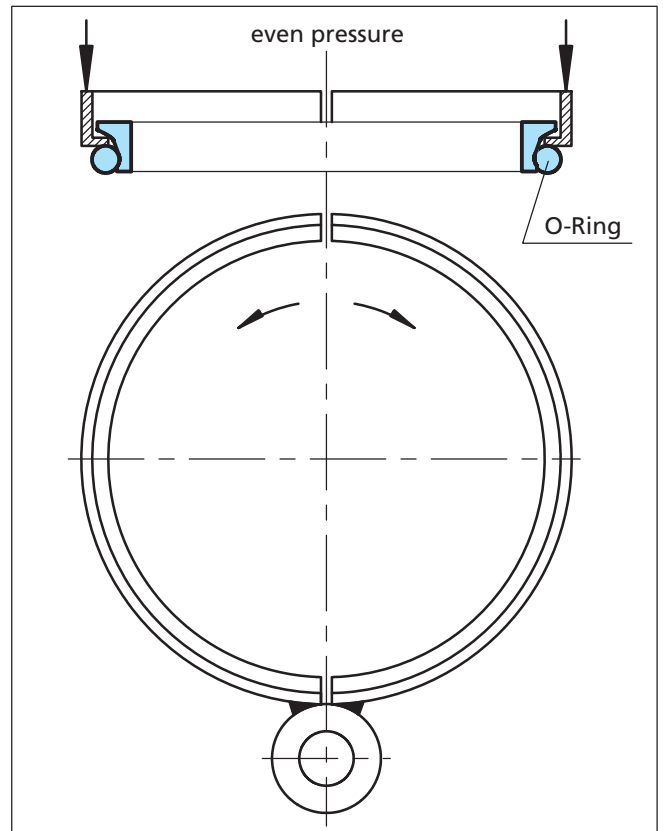

Figure 146 Fitting Tool

In the event that the installation tool cannot be withdrawn or where the seal is of a special design, an installation O-Ring can be used. The installation O-Ring is placed between the O-Ring of the seal and rear of the ramp on the Seal Ring. As force is applied to the Seal Ring during installation, the installation O-Ring backs up the O-Ring and will not allow it to roll up the ramp. After installation the O-Ring is easily removed (see figure below).

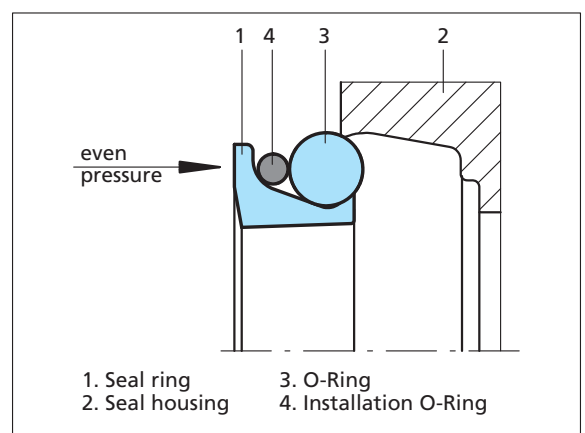

Figure 147 O-Ring as installation aid



Mechanical Face Seals

Installation Recommendations for Type DO in Bearing Steel

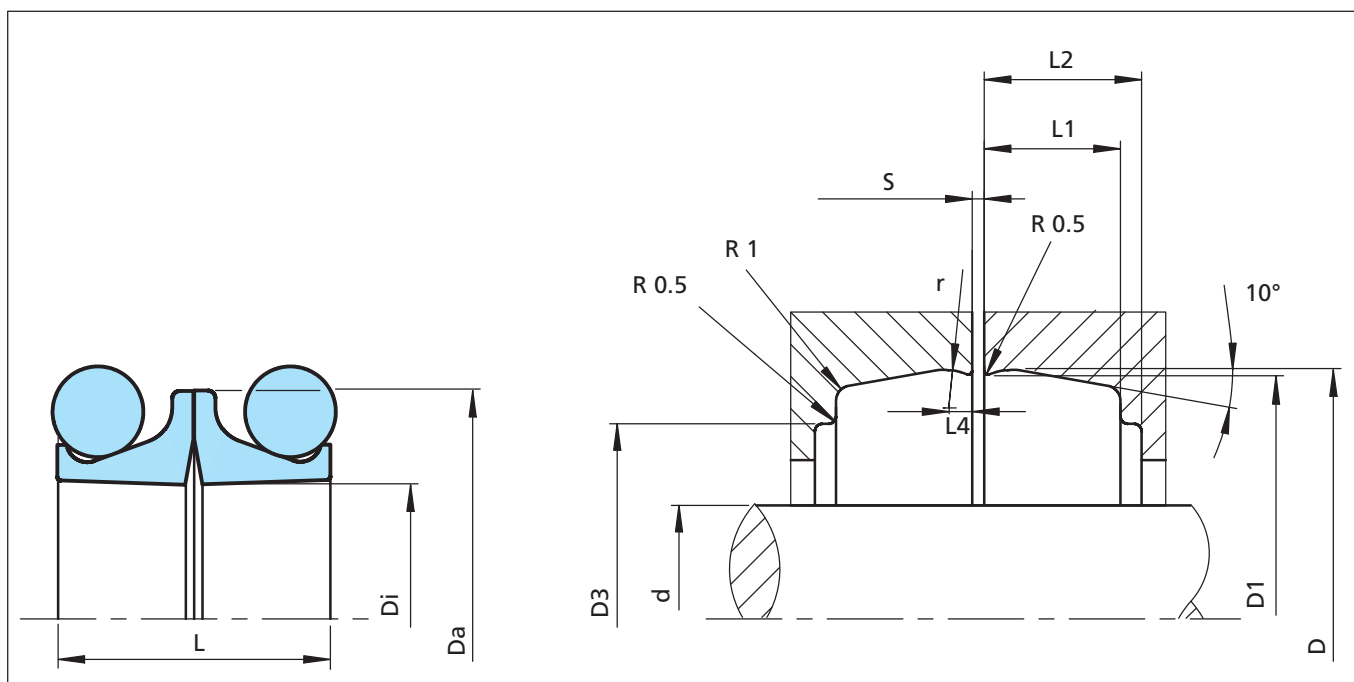

Figure 148 Installation Drawing

Table XCVII Installation Dimensions

TSS Part No.	GNL	D _i	D _a	L	d _{max.}	D _{±0.1}	D _{1±0.1}	D ₃	L ₁	L ₂ min.	L ₄	r	S
TLDOD1300	5731	130,00	152,00	32.0	127.0	155.5	154.5	145.0	15.0	19.0	7.5	5.0	3.0
TLDOA0340	5201	34.0	45.0	14.0	30.0	47.0	46.5	42.0	6.5	8.0	1.0	1.0	1.5
TLDOC0380	4301	38.0	51.0	20.4	35.0	53.7	53.0	46.0	9.0	11.0	1.8	2.0	3.0
TLDOA0390	5211	39.0	50.0	14.0	35.0	52.0	51.5	46.0	6.5	8.0	1.0	1.0	1.5
TLDOA0400	4701	40.0	52.0	20.0	36.0	55.0	54.2	46.0	9.0	11.0	1.0	1.0	3.0
TLDOA0430	4961	43.0	58.0	24.0	39.0	61.6	60.8	53.4	10.0	12.0	1.8	2.5	3.0
TLDOB0450	4821	45.0	58.0	21.6	41.0	61.6	61.0	54.0	10.5	12.5	1.8	2.5	3.0
TLDOA0460	4201	46.0	59.0	20.0	42.0	61.6	61.2	53.0	9.0	11.0	2.0	2.5	3.0
TLDOB0480	5241	48.0	58.0	14.4	44.0	59.9	59.4	55.0	6.3	8.0	1.5	1.7	1.5
TLDOC0480	5751	48.0	62.0	26.0	45.0	68.0	67.2	58.0	12.0	14.0	2.0	3.0	3.0
TLDOA0555	0496	55.5	70.0	22.0	52.0	73.8	73.1	65.5	10.0	11.5	2.4	5.0	3.0
TLDOB0560	5741	56.0	70.0	26.0	53.0	76.0	75.2	66.0	12.0	14.0	2.0	2.5	3.0
TLDOA0570	3786	57.0	77.5	35.6	54.0	81.4	80.7	68.5	15.2	20.9	3.5	4.8	
TLDOB0580	4851	58.0	75.0	27.0	53.0	79.2	78.6	66.0	12.0	14.0	2.0	2.5	3.0
TLDOA0600	4321	60.0	74.0	20.6	57.0	78.4	77.4	70.0	9.0	11.0	1.9	2.5	3.0
TLDOB0610	0441	61.0	73.0	17.6	58.0	75.8	75.5	66.8	6.5	7.5	1.0	1.4	3.0
TLDOB0635	3108	63.5	82.5	31.8	60.5	86.5	85.7	73.5	15.2	16.8	3.5	4.8	3.0

Missing values on request ¹⁾ α=12° ²⁾ α=15°

Mechanical Face Seals



TSS Part No.	GNL	D _i	D _a	L	d _{max.}	D±0.1	D ₁ ±0.1	D ₃	L ₁	L ₂ min.	L ₄	r	S
TLDOA0640	5681	64.0	78.0	25.0	61.0	84.6	83.8	74.0	12.5	14.5	2.0	3.0	3.0
TLDOA0675	5591	67.5	86.5	31.8	64.0	91.0	90.0	78.0	14.5	17.0	2.8	5.0	3.0
TLDOA0690	5631	69.0	84.0	24.0	66.0	89.6	88.6	78.5	11.0	13.0	1.9	3.0	3.0
TLDOB0690	5851	69.0	89.0	24.0	66.0	92.5	91.5	83.0	11.0	13.5	2.8	5.0	3.0
TLDOB0700	4871	70.0	90.0	29.0	65.0	95.5	94.7	84.0	13.5	15.5	2.0	3.0	3.0
TLDOB0710	5841	71.0	84.0	20.0	68.0	87.4	86.7	80.8	8.5	10.0	1.8	2.0	3.0
TLDOA0725	3751	72.5	92.0	35.6	70.1	96.0	95.2	83.0	15.2	20.9	3.5	4.8	
TLDOB0730	5611	73.0	92.0	31.8	70.0	96.2	95.4	84.0	15.0	17.0	2.8	4.0	3.0
TLDOA0731	3308	73.1	91.9	31.8	70.1	96.0	95.2	83.0	15.2	16.8	3.5	4.8	3.0
TLDOA0735	5481	73.5	88.5	20.4	70.0	90.2	89.4	82.0	12.7	14.3	2.2	2.8	3.0
TLDOB0740	4896	74.0	86.5	22.5	70.0	91.4	90.7	80.0	9.5	11.5	2.0	3.0	3.0
TLDOA0750	4901	75.0	94.0	29.0	73.0	101.4	100.6	89.0	14.5	16.5	2.0	3.0	3.0
TLDOA0775	3768	77.5	87.6	13.6	75.9	90.7	90.2	89.5	7.5	8.0	1.4	1.5	
TLDOA0795	5891	79.5	92.5	20.0	76.0	96.0	95.3	88.0	8.5	10.5	1.8	2.0	3.0
TLDOB0800	4931	80.0	100.0	30.0	76.0	104.1	103.3	93.0	15.0	18.0	2.3	2.5	3.0
TLDOA0810	5826	81.0	98.0	28.0	78.0	102.3	101.3	91.0	12.5	14.5	2.8	5.0	3.0
TLDOA0825	3771	82.5	102.0	35.6	80.5	107.3	106.5	94.3	15.2	20.9	3.5	4.8	
TLDOB0900	3711	90.0	105.0	26.0	87.4	107.3	106.7	100.4	11.5	14.0	2.9	2.8	3.0
TLDOA0904	3504	90.4	109.4	31.8	87.4	113.4	112.7	100.4	15.2	16.8	3.5	4.8	3.0
TLDOB0904	3743	90.4	109.5	35.6	88.5	113.4	112.7	100.4	15.2	20.9	3.5	4.8	
TLDOB0920	4886	92.0	109.5	22.0	88.0	113.8	113.0	105.0	9.5	11.5	2.0	3.0	3.0
TLDOB0940	4946	94.0	106.5	23.0	90.0	111.6	110.8	102.0	9.5	11.5	2.0	3.0	3.0
TLDOA0950	0181	95.0	111.0	24.0	92.0	115.6	114.8	108.0	11.0	12.5	1.8	2.0	3.0
TLDOC0950	5701	95.0	114.0	32.0	91.0	120.0	119.2	107.0	15.0	17.0	2.5	3.0	3.0
TLDOA0965	3761	96.5	106.8	13.6	94.9	109.7	109.2	108.5	7.5	8.0	1.4	1.5	3.0
TLDOA1000	3607	100.0	119.0	31.8	97.0	123.0	122.2	110.0	15.2	16.8	3.5	4.8	3.0
TLDOA1030	1801	103.0	122.0	32.0	99.0	127.2	126.2	115.0	15.5	17.5	2.5	3.0	3.0
TLDOD1040	4866	104.0	117.0	22.0	100.0	121.0	120.2	107.0	9.5	11.5	2.0	3.0	3.0
TLDOE1040	4856	104.0	122.5	22.5	100.0	125.5	125.1	117.5	9.5	11.5	2.0	3.0	3.0
TLDOF1040	8001	104.0	125.0	28.0	100.0	128.5	127.5	117.0	12.5	14.0	2.8	5.0	3.0
TLDOA1070	0486	107.0	125.0	24.0	103.0	130.4	129.4	119.5	11.0	13.5	2.8	5.0	3.0
TLDOA1090	4841	109.0	132.0	32.0	104.0	136.5	135.5	124.0	15.5	17.5	2.5	3.0	3.0
TLDOB1100	5501	110.0	128.0	32.0	106.0	133.0	132.0	121.0	14.5	17.0	2.5	3.0	3.0
TLDOB1110	5443	111.0	128.0	22.0	107.0	132.5	132.0	123.0	10.6	12.3	2.8	3.0	3.0
TLDOA1110	0290	111.0	133.0	32.0	108.0	137.0	136.5	124.5	14.5	18.0	2.8	5.0	5.0
TLDOA1145	0179	114.5	129.0	23.5	107.5	134.1	133.1	126.0	10.4	11.9	2.8	5.0	3.0
TLDOA1150	4881	115.0	137.0	31.0	110.0	141.8	140.8	130.0	14.5	16.5	2.5	3.0	3.0
TLDOA1170	5816	117.0	138.0	31.8	114.0	142.5	141.5	132.0	14.5	17.0	2.8	5.0	3.0
TLDOB1170	5801	117.0	140.0	28.0	113.0	142.5	141.5	132.0	12.5	14.0	2.8	5.0	3.0
TLDOA1190	5361	119.0	140.0	28.0	115.0	142.5	141.5	132.0	12.5	14.0	2.8	5.0	3.0
TLDOA1200	4711	120.0	139.0	31.8	115.0	143.0	142.0	129.3	14.3	17.4	3.0	5.4	3.0

Missing values on request ¹⁾ α=12° ²⁾ α=15°



Mechanical Face Seals

TSS Part No.	GNL	D _i	D _a	L	d _{max.}	D±0.1	D ₁ ±0.1	D ₃	L ₁	L ₂ min.	L ₄	r	S
TLDOC1200	5461	120.0	141.0	31.8	117.0	144.0	143.0	138.0	14.5	17.5	2.8	5.0	3.0
TLDOD1200	5641	120.0	142.0	38.0	116.0	149.0	148.0	133.0	17.0	19.0	2.5	3.0	4.0
TLDOA1240	4926	124.0	141.0	22.0	120.0	146.4	145.3	136.0	10.6	12.3	2.8	3.0	3.0
TLDOB1250	4221	125.0	144.1	31.8	120.0	148.5	147.5	136.0	14.3	17.4	3.0	5.0	3.0
TLDOA1260	3516	126.0	146.0	31.8	123.0	150.0	149.2	137.0	15.2	16.8	3.5	4.8	3.0
TLDOA1265	5539	126.5	139.0	26.8	123.5	143.8	143.1	136.9	11.8	14.2	2.9	2.8	3.0
TLDOC1270	0451	127.0	141.0	29.0	124.0	144.0	143.0	136.0	12.0	14.5	2.8	5.0	3.0
TLDOD1270	3851	127.0	141.2	25.4	124.0	143.8	143.1	136.9	11.8	14.2	2.9	2.8	3.0
TLDOA1270	3701	127.0	146.0	31.8	124.0	150.5	149.5	138.0	14.5	17.5	2.8	5.0	4.0
TLDOB1300	4911	130.0	150.5	32.0	125.0	155.6	154.6	144.0	14.5	16.5	2.5	5.0	3.0
TLDOA1427	3841	142.7	156.9	25.4	139.7	159.7	158.9	152.1	11.8	14.2	2.9	2.8	3.0
TLDOB1430	5451	143.0	160.0	27.0	138.0	164.0	163.0	154.0	12.0	14.5	2.8	5.0	4.0
TLDOA1440	0276	144.0	157.0	26.0	140.0	160.0	159.0	154.5	12.0	14.5	2.8	5.0	3.0
TLDOB1460	5596	146.0	168.0	38.0	143.0	176.8	175.9	159.0	18.0	20.5	3.0	6.5	4.0
TLDOC1460	5101	146.0	175.0	38.0	142.0	180.5	179.5	162.0	17.7	20.5	3.0	6.3	6.0
TLDOA1463	3121	146.3	171.7	38.0	143.3	176.8	175.9	158.9	18.4	20.3	3.7	6.3	
TLDOA1470	5541	147.0	167.0	28.0	142.0	171.0	170.0	160.0	13.0	15.5	2.8	5.0	3.0
TLDOA1480	4811	148.0	170.0	31.0	142.0	175.6	174.6	164.0	15.0	17.0	2.5	3.0	4.0
TLDOC1500	5621	150.0	172.0	40.0	147.0	179.0	178.0	165.0	18.0	20.0	2.5	2.0	4.0
TLDOA1520	4351	152.0	171.5	32.0	149.0	175.4	174.7	162.5	15.2	16.8	3.5	4.8	
TLDOA1530	0436	153.0	171.5	28.0	149.0	176.3	175.3	164.5	12.5	14.5	2.8	5.0	3.0
TLDOA1539	3831	153.9	168.1	25.4	150.9	171.0	170.2	164.0	11.8	14.2	2.9	2.8	3.0
TLDOA1540	0446	154.0	168.0	27.0	150.0	171.0	170.0	162.5	12.0	14.5	2.3	3.0	3.0
TLDOD1540	0491	154.0	169.0	22.0	150.0	174.5	173.5	166.0	9.2	11.0	2.3	3.0	3.0
TLDOE1540	0426	154.0	170.0	21.0	150.0	175.1	174.1	167.0	9.2	10.0	2.3	3.0	3.0
TLDOC1540	0476	154.0	173.5	32.0	151.0	178.0	177.0	166.0	14.5	17.0	2.8	6.5	3.0
TLDOA1633	3243	163.3	191.2	38.0	160.3	196.8	195.8	178.9	18.4	20.3	3.7	6.3	6.0
TLDOB1633	3221	163.3	191.3	46.0	160.0	196.8	195.9	178.9	18.4	24.1	3.7	6.3	6.0
TLDOA1640	0471	164.0	189.0	30.0	160.0	193.5	192.5	179.0	14.5	17.0	2.8	5.0	3.0
TLDOA1650	5871	165.0	181.0	27.0	161.0	185.0	184.0	176.5	12.0	14.5	2.7	4.0	3.0
TLDOA1725	5531	172.5	190.0	25.4	168.0	192.7	191.8	188.0	12.7	14.3	2.3	2.8	3.0
TLDOA1740	5546	174.0	190.0	25.4	170.0	192.7	191.8	188.0	12.7	14.3	2.3	2.8	3.0
TLDOA1770	0401	177.0	200.0	31.0	173.0	204.5	203.4	191.0	14.5	17.0	3.1	5.0	3.0
TLDOA1780	5866	178.0	199.0	32.0	175.0	203.6	202.4	190.0	23.0	16.0	3.0	5.0	3.0
TLDOB1780	5711	178.0	200.0	38.0	175.0	210.6	209.6	192.0	19.0	21.0	3.0	4.0	4.0
TLDOA1800	5526	180.0	197.4	21.4	173.0	202.2	201.9	196.0	9.4	10.6	1.2	3.0	3.0
TLDOA1823	3261	182.3	210.3	38.0	179.3	215.4	214.4	197.5	18.4	20.3	3.7	6.3	6.0
TLDOA1824	3209	182.4	210.3	46.0	179.0	215.4	214.4	197.5	18.4	24.1	3.7	6.3	6.0
TLDOB1830	0201	183.0	202.0	28.0	179.0	206.0	205.0	195.0	12.5	14.5	2.8	5.0	3.0
TLDOA1860	5131	186.0	203.0	25.4	182.0	205.7	204.9	190.5	14.5	16.0	2.3	2.8	3.0
TLDOA1910	5856	191.0	210.0	28.0	187.0	214.0	213.0	203.0	12.5	14.5	2.8	5.0	3.0

Missing values on request ¹⁾ α=12° ²⁾ α=15°

Mechanical Face Seals



TSS Part No.	GNL	D _i	D _a	L	d _{max.}	D±0.1	D ₁ ±0.1	D ₃	L ₁	L ₂ min.	L ₄	r	S
TLDOA1920	5421	192.0	215.0	33.0	189.0	220.8	219.8	207.0	16.5	18.5	3.0	4.0	4.0
TLDOA1950	0188	195.0	216.5	32.0	191.0	221.0	220.0	207.0	14.5	17.0	2.8	5.0	3.0
TLDOA2000	5111	200.0	228.5	38.0	196.0	233.5	232.5	215.5	18.0	20.5	3.1	6.3	6.0
TLDOA2020	3871	202.0	222.3	26.5	197.0	224.9	224.1	217.9	11.8	14.2	2.9	2.8	3.0
TLDOA2050	5821	205.0	227.0	30.0	198.0	231.5	230.5	219.0	14.5	17.0	2.8	5.0	3.0
TLDOA2090	5651	209.0	234.0	42.0	206.0	242.6	241.6	224.0	19.5	22.5	3.0	4.0	4.0
TLDOA2200	5881	220.0	239.5	32.0	215.0	244.0	243.0	232.0	14.5	16.5	2.8	5.0	3.0
TLDOA2240	3345	223.5	251.4	38.0	220.5	256.5	255.7	238.7	18.4	20.3	3.7	6.3	6.0
TLDOC2235	3320	223.5	251.5	46.0	220.0	256.6	255.7	238.7	18.4	24.1	3.7	6.3	3.0
TLDOA2250	4831	225.0	252.0	38.0	220.0	258.0	257.0	241.0	19.0	21.0	3.0	4.0	4.0
TLDOA2316	3861	231.6	259.6	38.0	228.0	264.7	263.8	247.0	18.4	20.5	3.7	6.3	6.0
TLDOA2380	0176	238.0	261.0	32.0	231.0	265.5	264.5	254.0	14.5	17.0	2.8	5.0	3.0
TLDOA2390	4861	239.0	268.0	40.0	234.0	274.2	273.2	257.0	20.5	22.5	3.0	4.0	4.0
TLDOC2400	0411	240.0	262.8	38.0	236.0	273.5	272.5	255.5	18.0	20.5	3.1	6.5	3.0
TLDOA2450	0161	245.0	264.5	32.0	238.0	268.9	267.9	255.0	14.5	17.0	2.8	5.0	3.0
TLDOB2500	5721	250.0	276.0	44.0	247.0	284.6	283.6	266.0	20.5	24.0	3.0	4.0	4.0
TLDOA2520	5811	252.0	280.0	38.0	248.0	285.5	284.5	265.0	18.0	20.0	3.1	6.5	3.0
TLDOB2650	3526	265.0	292.8	46.0	261.0	297.8	297.0	280.0	18.4	24.1	3.7	6.3	6.0
TLDOA2650	3519	265.0	293.0	38.0	261.0	298.0	297.0	280.0	18.0	20.5	3.1	6.3	4.0
TLDOA2750	5846	275.0	303.0	38.0	271.0	308.0	307.0	290.0	18.0	20.5	3.1	6.5	3.0
TLDOA2829	3777	282.9	310.8	38.0	280.0	316.3	315.4	298.4	18.4	20.3	3.7	6.3	6.0
TLDOB3000	4891	300.0	328.0	40.0	295.0	333.0	332.0	315.0	18.5	21.0	3.0	4.0	4.0
TLDOA3010	3780	301.0	328.0	38.0	297.0	333.0	332.1	315.1	18.4	20.3	3.7	6.3	6.0
TLDOA3180	0166	318.0	341.0	38.0	315.0	351.5	350.5	334.0	18.0	20.5	3.1	6.5	3.0
TLDOA3185	3622	318.5	346.4	38.0	315.5	351.6	350.7	333.7	18.4	20.3	3.7	6.3	6.0
TLDOA3190	3619	319.0	346.5	46.0	315.0	351.6	350.7	333.7	18.4	24.1	3.7	6.3	6.0
TLDOA3395	4921	339.5	369.0	40.0	335.0	374.8	373.8	358.0	19.0	21.5	3.0	4.0	4.0
TLDOA3400	0171	340.0	368.0	40.0	337.0	374.8	373.8	358.0	19.0	21.5	3.0	4.0	3.0
TLDOA3500	5861	350.0	375.0	38.0	345.0	385.0	384.5	368.0	17.5	20.5	3.1	6.5	3.0
TLDOC3665	3801	366.5	394.4	38.0	363.5	399.5	398.6	381.7	18.4	20.3	3.7	6.3	6.0
TLDOD3665	3981	366.5	394.5	48.0	363.5	399.5	398.6	381.7	18.4	24.1	3.7	6.3	6.0
TLDOA3672	3844	367.2	394.5	38.0	364.2	399.5	398.6	381.7	18.4	20.3	3.7	6.3	6.0
TLDOA3700	5141	370.0	398.0	38.0	365.0	403.5	402.6	385.0	17.5	20.5	3.0	6.5	3.0
TLDOA3805	4966	380.5	405.0	40.0	375.0	412.2	410.5	395.0	17.0	22.0	3.0	4.0	4.0
TLDOA3870	5896	387.0	415.0	38.0	382.0	420.3	419.3	402.0	17.5	20.5	3.1	6.5	3.0
TLDOA4285	5761	428.5	454.0	37.0	425.0	462.3	461.3	444.6	18.5	21.0	3.0	4.0	4.0
TLDOA4292	3811	429.2	457.2	38.0	426.2	462.3	461.4	444.4	18.4	20.3	3.7	6.3	6.0
TLDOA4700	0461	470.0	500.0	50.0	465.0	512.2	510.2	490.0	23.5	25.5	13.0	6.0	3.0
TLDOA5054	3821	505.4	533.4	44.0	502.4	538.5	537.6	520.6	21.3	26.2	3.7	6.3	6.0
TLDOA5300	5878	530.0	560.0	50.0	524.0	572.2	570.2	545.0	23.5	25.5	4.0	6.0	3.0
TLDOA5800	0421	580.0	608.0	43.6	575.5	613.0	611.0	596.0	19.7	21.7	4.0	6.5	6.0

Missing values on request ¹⁾ α=12° ²⁾ α=15°



Mechanical Face Seals

TSS Part No.	GNL	D _i	D _a	L	d _{max.}	D±0.1	D ₁ ±0.1	D ₃	L ₁	L ₂ min.	L ₄	r	S
TLDOA5910	0456	591.0	623.0	50.0	585.0	635.2	632.1	613.0	23.5	25.5	4.0	6.0	5.0
TLDOA6670	3876	667.0	700.0	44.0	660.0	705.6	704.6	687.6	18.4	23.4	3.7	6.3	6.0
TLDOA7100	0431	710.0	750.0	50.0	700.0	762.2	760.2	740.0	23.5	25.5	4.0	6.0	3.0
TLDOA8300	5836	830.0	886.0	80.0	815.0	891.6	890.6	860.0	34.5	39.5	4.4	10.0	17.0

Missing values on request ¹⁾ α=12° ²⁾ α=15°

Ordering Example

Mechanical Face Seal Type DO in Bearing Steel

Inside diameter D_i = 125.0 mm

Materials: Seal rings of Bearing Steel (1.3505)
O-Rings of NBR

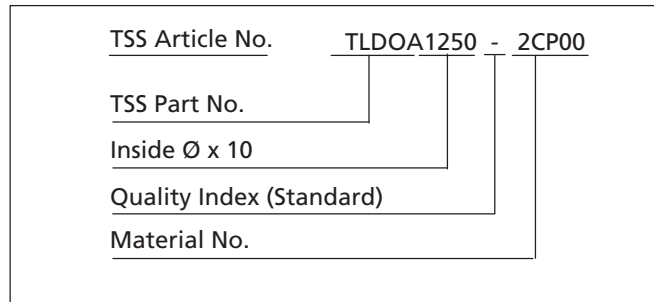

Dimensions and Part-Number see Table XCVII, page 292.
Materials see page 289.



■ Installation Recommendations for Type DO in Cast Iron

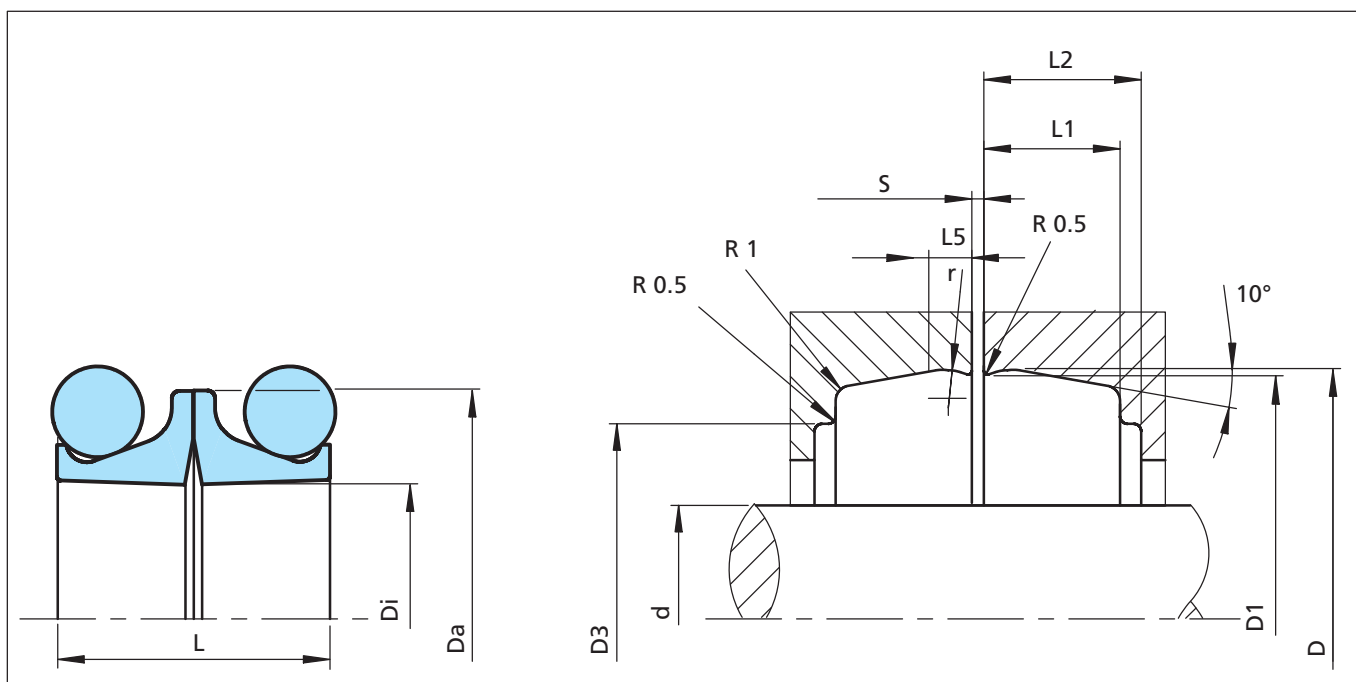

Figure 149 Installation Drawing

Table XCVIII Installation Dimensions

TSS Part No.	D _i	D _a	L	d _{max.}	D±0.1	D ₁ ±0.1	D ₃	L ₁	L ₂ min.	L ₅	r	S
TLDOA0380	38.0	51.0	20.0	35.0	53.7	53.0	46.0	9.0	11.0	1.6	2.0	3.0
TLDOA0430	43.0	58.0	24.0	40.0	62.0	61.3	51.0	10.5	12.5	2.0	2.0	3.0
TLDOA0450	45.0	58.0	21.0	42.0	61.6	60.8	53.4	10.0	12.0	1.8	2.5	3.0
TLDOA0480	48.0	62.0	25.0	45.0	68.0	67.2	58.0	12.0	14.0	2.0	3.0	3.0
TLDOA0555	55.5	70.0	22.0	52.5	73.8	73.1	55.5	10.0	11.5	2.4	5.0	3.0
TLDOA0560	56.0	70.0	25.0	53.0	76.0	75.2	66.0	12.0	14.0	2.0	3.0	3.0
TLDOA0580	58.0	74.0	27.0	55.0	79.4	78.6	67.0	13.5	15.5	2.0	3.0	3.0
TLDOA0600	60.0	74.0	20.6	57.0	78.4	77.4	70.0	9.0	11.0	1.9	2.5	3.0
TLDOA0610	61.0	73.0	17.6	58.0	75.8	75.5	68.5	8.0	9.5	1.4	1.5	2.0
TLDOA0635	63.5	82.5	31.8	60.5	86.8	85.9	74.0	15.0	17.0	3.0	2.5	3.0
TLDOA0640	64.0	78.0	25.0	61.0	84.6	83.6	74.0	12.5	14.5	2.0	3.0	3.0
TLDOA0660	66.0	85.0	28.0	63.0	90.0	89.2	78.0	14.0	16.0	2.0	3.0	3.0
TLDOA0690	69.0	84.0	24.0	66.0	89.6	88.6	78.5	11.0	13.0	1.9	3.0	3.0
TLDOA0710	71.0	90.0	29.0	68.0	95.5	94.7	84.0	13.5	15.5	2.0	3.0	3.0
TLDOA0730	73.0	92.0	31.8	70.0	96.2	95.4	84.0	15.0	17.0	3.0	2.5	3.0
TLDOA0740	74.0	86.6	22.0	71.0	91.4	90.7	80.0	9.5	11.5	2.0	3.0	3.0
TLDOA0800	80.5	99.5	29.0	77.0	105.0	104.2	92.0	14.5	16.5	2.0	3.0	3.0

Missing values on request ¹⁾ α=12° ²⁾ α=15°



Mechanical Face Seals

TSS Part No.	D _i	D _a	L	d _{max.}	D±0.1	D ₁ ±0.1	D ₃	L ₁	L ₂ min.	L ₅	r	S
TLDOA0810	81.0	98.0	28.0	78.0	102.3	101.1	91.0	12.5	14.5	2.8	5.0	
TLDOA0820	82.0	98.0	22.0	79.0	102.3	101.3	91.0	9.0	11.0	2.8	5.0	3.0
TLDOA0900	90.5	109.0	32.0	87.0	113.6	112.9	101.0	15.0	17.0	3.0	2.5	3.0
TLDOA0920	92.0	109.0	22.0	89.0	113.8	113.0	105.0	9.5	11.5	1.8	2.5	3.0
TLDOA0940	94.0	106.5	22.0	91.0	111.6	110.8	102.0	9.5	11.5	2.0	3.0	3.0
TLDOB0950	95.0	114.0	31.0	92.0	120.0	119.2	107.0	15.0	17.0	2.5	3.0	3.0
TLDOA0990	99.0	120.0	28.0	96.0	123.5	122.5	112.0	12.5	14.5	2.8	5.0	3.0
TLDOA1000	100.0	119.0	31.8	97.0	123.2	122.4	111.0	14.5	16.5	2.5	2.5	3.0
TLDOB1000	100.0	120.0	29.4	97.0	125.0	124.2	111.0	14.0	16.0	2.9	3.0	3.0
TLDOA1020	102.0	122.0	32.0	99.0	127.2	126.2	115.0	15.5	17.5	2.5	3.0	3.0
TLDOB1040	104.0	116.7	21.2	101.0	121.0	120.2	107.0	9.5	11.5	2.0	3.0	3.0
TLDOC1040	104.0	121.0	22.0	101.0	125.5	125.1	117.5	9.5	11.5	2.0	3.0	3.0
TLDOB1100	109.0	127.0	32.0	106.0	133.0	132.0	121.0	15.0	17.0	2.5	3.0	3.0
TLDOA1090	109.0	132.0	32.0	106.0	136.6	135.6	124.0	15.5	17.5	2.5	3.0	3.0
TLDOA1150	115.0	137.0	31.0	112.0	141.8	140.8	130.0	14.5	16.5	2.5	3.0	3.0
TLDOA1240	124.0	141.0	22.0	121.0	145.8	145.0	136.0	9.5	11.5	2.0	3.0	3.0
TLDOA1270	127.0	146.0	31.8	123.0	150.2	149.4	138.0	14.0	16.0	2.5	2.5	4.0
TLDOD1300	130.0	152.0	38.0	127.0	159.0	158.0	144.0	18.5	20.5	2.5	3.0	3.0
TLDOB1430	143.0	157.0	25.0	140.0	159.7	158.9	152.0	11.5	13.5	2.5	2.8	4.0
TLDOA1460	146.0	168.0	38.0	143.0	177.0	176.0	159.0	18.0	20.0	2.5	3.0	4.0
TLDOC1500	150.0	172.0	40.0	147.0	179.0	178.0	165.0	18.0	20.0	2.5	3.0	4.0
TLDOB1530	154.0	168.0	25.0	151.0	171.0	170.2	164.0	11.5	13.5	2.5	2.8	4.0
TLDOB1630	163.0	191.0	38.0	160.0	196.4	195.5	179.0	18.0	20.0	3.1	6.4	4.0
TLDOA1910	191.0	210.0	28.0	187.0	214.0	213.0	203.0	12.5	14.5	2.8	5.0	3.0
TLDOA1920	192.0	215.0	33.0	189.0	220.8	219.8	207.0	16.5	18.5	3.0	4.0	4.0
TLDOA2090	209.0	234.0	42.0	206.0	242.6	241.6	224.0	19.5	21.5	3.0	4.0	4.0
TLDOA2200	220.0	239.5	31.8	217.0	244.0	243.0	232.0	14.5	16.5	2.8	5.0	3.0
TLDOA2240	223.5	252.0	38.0	220.0	256.6	255.7	238.0	18.0	20.0	3.1	6.4	2.0
TLDOA2400	240.0	262.8	38.0	237.0	273.5	272.5	257.0	19.0	21.0	3.0	4.0	4.0
TLDOA2500	250.0	276.0	41.0	247.0	284.6	283.6	266.0	20.5	22.5	3.0	4.0	4.0
TLDOA2650	265.0	293.0	38.0	262.0	298.0	297.0	280.0	19.0	21.0	3.0	6.4	4.0
TLDOA2750	275.0	303.0	38.0	271.0	308.0	307.0	290.0	18.0	20.5	3.1	4.0	
TLDOB3000	300.0	328.0	39.0	297.0	333.0	332.0	315.0	19.5	22.0	3.0	4.0	4.0
TLDOA3180	318.0	341.0	38.0	315.0	351.6	350.7	335.0	19.0	20.5	3.0	6.4	
TLDOA3185	318.5	346.5	38.0	315.0	351.6	350.6	335.0	19.0	21.5	3.0	6.4	
TLDOA3400	340.0	368.0	38.0	333.0	375.7	374.8	368.0	19.6	22.1	3.1	4.0	3.0
TLDOB3665	366.5	391.0	38.0	363.0	399.5	398.5	382.0	18.5	21.0	3.0	4.0	4.0
TLDOA3665	366.5	394.5	38.0	363.0	399.5	398.6	382.0	18.5	21.0	3.0	6.4	4.0
TLDOA3870	387.0	415.0	38.0	384.0	419.5	418.5	400.0	18.0	20.5	3.0	4.0	3.0
TLDOA4290	429.0	457.0	38.0	426.0	463.5	462.5	444.0	18.0	20.5	3.0	4.0	3.0

Missing values on request ¹⁾ α=12° ²⁾ α=15°



Ordering Example

Mechanical Face Seal Type DO in Cast Iron

Inside diameter Di = 115.0 mm

Materials: Seal rings of Cast Iron
O-Rings of NBR

<u>TSS Article No.</u>	<u>TLDOA1150</u>	-	<u>2FP00</u>
<u>TSS Part No.</u>			
<u>Inside Ø x 10</u>			
<u>Quality Index (Standard)</u>			
<u>Material No.</u>			

Dimensions and Part Number see Table XCVIII, page 297.
Materials see page 289.



■ Installation Recommendations for Type DF Bearing Steel

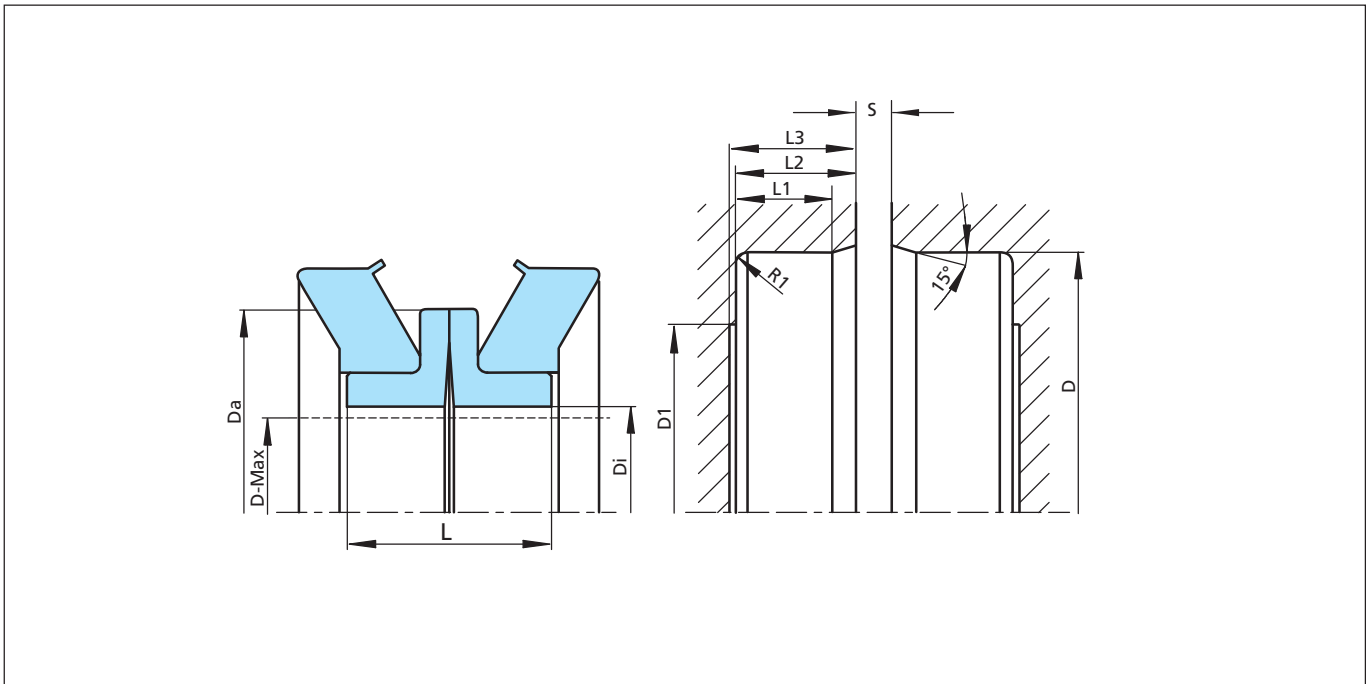

Figure 150 Installation Drawing

Table XCIX Installation Dimension

TSS Part No.	GNL	D_i	D_a	L	$d_{max.}$	D	D_1	L_1	L_2	L_3	S
TL DFA0420	0627	42.0	59.0	20.0	38.0	65.0	53.0	8.0	10.0	10.5	3.0
TL DFA0470	5301	47.0	62.0	20.0	44.0	70.0	58.0	8.0	10.0	11.0	3.0
TL DFA0505	6161	50.5	65.0	19.0	46.0	76.2	63.0	8.0	10.0	11.0	2.5
TL DFA0540	0870	54.0	73.0	22.0	50.0	80.0	67.0	10.0	11.5	12.0	3.0
TL DFA0585	2011	58.5	73.0	19.0	54.0	82.5	65.0	8.0	10.0	11.0	3.0
TL DFA0586	0351	58.6	80.0	19.6	57.0	84.0	71.0	7.5	9.0	9.5	3.0
TL DFA0635	5471	63.5	81.0	19.0	59.5	87.8	71.0	8.0	9.0	9.5	3.0
TL DFA0670	6361	67.0	86.2	20.0	64.0	95.4	82.0	8.0	10.0	11.0	3.0
TL DFB0670	0926	67.0	87.0	25.0	64.0	95.0	81.0	11.0	12.5	13.0	4.0
TL DFC0670	6391	67.0	91.7	20.0	64.0	95.4	82.0	8.0	10.0	11.0	3.0
TL DFA0680	0691	68.0	86.2	20.0	64.0	95.6	82.0	8.0	10.0	11.0	3.5
TL DFA0738	6461	73.8	92.8	20.0	70.0	102.2	88.0	8.0	10.0	11.0	3.0
TL DFA0740	6571	74.0	99.0	20.0	70.0	102.2	88.0	8.0	10.0	11.0	3.0
TL DFA0770	1002	77.0	97.0	25.0	74.0	105.0	87.0	11.0	12.5	13.5	4.0
TL DFA0817	5311	81.7	101.5	20.0	70.0	110.2	96.0	8.0	10.0	11.0	3.0
TL DFA0825	2001	82.5	100.0	22.0	78.0	114.3	97.0	9.0	11.0	12.0	3.5
TL DFA0875	0331	87.5	109.0	17.5	83.0	113.0	100.0	7.0	8.5	9.5	3.0
TL DFB0875	0398	87.5	111.5	19.0	85.0	115.8	102.0	8.5	10.0	11.0	3.0

Mechanical Face Seals



TSS Part No.	GNL	D _i	D _a	L	d _{max.}	D	D ₁	L ₁	L ₂	L ₃	S
TL DFA0920	0751	92.0	113.0	24.0	88.0	125.8	109.0	10.0	12.5	13.0	3.0
TL DFA0940	6661	94.0	112.5	24.0	90.0	125.8	109.0	10.0	12.5	13.0	3.0
TL DFA0990	0341	99.0	120.0	17.5	95.0	124.0	110.0	7.0	8.5	9.5	3.0
TL DFB0990	0399	99.0	123.0	19.0	95.0	127.3	113.0	7.0	10.0	11.0	3.0
TL DFA1040	0911	104.0	126.0	24.0	100.0	135.0	114.0	10.0	12.0	13.0	4.0
TL DFB1050	2081	105.0	124.0	24.4	101.0	134.9	125.0	12.0	13.3	14.5	3.0
TL DFA1140	2071	114.0	133.2	26.0	110.0	147.9	130.0	10.5	12.0	13.0	4.0
TL DFB1140	0666	114.0	138.0	26.0	110.0	148.0	126.0	10.0	12.0	13.0	4.0
TL DFA1240	5371	124.0	144.0	32.0	119.0	162.5	141.5	17.0	18.5	20.5	3.0
TL DFA1330	1311	133.0	156.0	28.0	128.0	171.5	151.0	11.0	13.0	14.0	6.5
TL DFA1485	5001	148.5	168.0	32.4	143.0	184.1	164.0	15.0	16.5	17.5	5.0
TL DFA1500	0885	150.0	175.0	30.0	145.0	190.0	170.0	13.0	15.0	15.5	5.0
TL DFA1540	2021	154.0	180.0	36.0	149.0	194.0	174.0	17.0	18.4	20.0	4.5
TL DFA1580	0791	158.0	180.0	18.0	153.0	190.0	174.0	7.0	8.0	10.0	6.0
TL DFA1690	2041	169.0	195.0	33.0	164.0	206.2	191.5	14.0	15.1	18.4	5.0
TL DFA1777	5931	177.7	207.0	29.0	173.0	218.9	197.0	15.0	16.6	17.5	
TL DFA1930	6671	193.0	214.3	31.0	187.0	238.9	215.0	18.0	19.4	20.4	3.0
TL DFA1940	5941	194.0	214.5	31.0	188.0	238.8	214.0	19.0	20.1	21.0	
TL DFA1980	0937	198.0	224.0	35.0	195.0	245.0	223.0	15.0	17.0	17.5	6.0
TL DFA2280	2051	228.0	260.5	41.0	221.0	277.1	247.5	22.0	23.5	24.5	4.0
TL DFA2330	1023	233.0	259.0	35.0	225.0	280.0	250.0	15.0	17.0	18.0	6.0
TL DFA2415	6481	241.5	273.5	36.0	235.0	279.4	260.6	16.5	17.5	20.0	2.0
TL DFA2750	5951	275.0	303.0	36.0	270.0	309.4	290.0	16.5	17.5	20.0	2.0
TL DFA2830	5901	283.0	305.0	42.0	278.0	329.4	307.0	17.0	18.5	22.1	3.0
TL DFA3200	5921	320.0	352.5	40.0	312.0	365.1	343.0	18.5	20.0	21.5	2.0
TL DFA3550	2031	355.0	392.0	39.6	345.0	401.7	380.0	21.5	23.0	24.0	1.8
TL DFA4420	6561	442.0	470.0	41.0	435.0	488.7	467.0	17.0	18.4	22.0	2.5
TL DFA4920	5911	492.0	530.0	43.0	480.0	546.1	532.0	18.4	19.9	24.4	2.0

Ordering Example

Mechanical Face Seal Type DF in Bearing Steel

Inside diameter: Di = 150 mm

Material: Sealing ring of Bearing Steel
Square ring of NBR

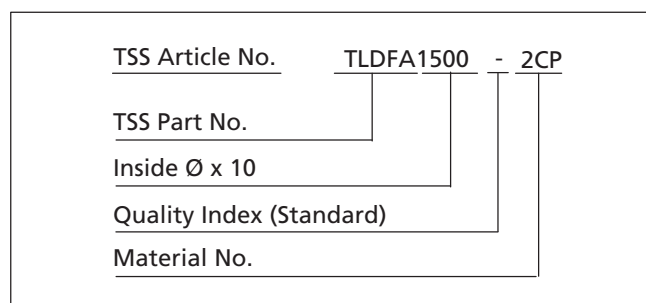

■ General quality criteria and storage guidelines

■ Quality criteria

The cost-effective use of seals and bearings is highly influenced by the quality criteria applied in production. Seals and bearings from Trelleborg Sealing Solutions are continuously monitored according to strict quality standards from material acquisition through to delivery.

Certification of our production plants in accordance with international standards QS 9000/ISO 9000 meets the specific requirements for quality control and management of purchasing, production and marketing functions.

Our quality policy is consistently controlled by strict procedures and guidelines which are implemented within all strategic areas of the company.

All testing of materials and products is performed in accordance with accepted test standards and specifications, e.g. random sample testing in accordance with ISO 2859-1:2004-01 AQL 1,0 general inspection level II.

Inspection specifications correspond to standards applicable to individual product groups (e.g. for O-Rings: ISO 3601).

Our sealing materials are produced free of chlorofluorinated hydrocarbons and carcinogenic elements.

■ Storage and shelf life of polymer sealing material

Seals and bearings are often stored for long time periods. Due to wrong storage conditions the physical properties of elastomers may change during storage. Because of hardening, softening, crack initiation, breakage or other degradation they can become unusable. These types of material deterioration are the result of particular factors or a combination of factors such as deformation, high temperatures, contact with oxygen, ozone, light, humidity or other media.

A few simple precautions can help to extend shelf life of seals considerably. Basic instructions for the storage, cleaning and maintenance of elastomer sealing elements are described in international standards, such as: DIN 7716/BS 3F68, ISO 2230 or DIN 9088

These standards provide several recommendations for the storage and the shelf life of elastomers, depending on the type of material.

The following requirements for storage of elastomers and other polymers, based on the recommendations of these standards, need to be followed to preserve the physical and chemical properties of such seals.

Heat

The storage temperature should preferably be between +5 °C/+41 °F and +25 °C/+77 °F. Direct contact with heat sources such as boilers, radiators or direct sunlight are to be avoided. During storage at low temperatures, elastomers can stiffen. Therefore the handling of seals at low temperatures must be done very carefully in order to avoid deformation or damage.

Humidity

The relative humidity in the storage area should be below 70 %. Extreme humid or extreme dry conditions are to be avoided. Condensation must not develop.

Light

Elastomer seals must be protected from light sources during storage. In particular direct sunlight and strong artificial light with an ultraviolet content shall be avoided. The original storage bags, especially plastic bags, are to be favored if they provide UV protection.

In case of strong external light exposure it is recommended to mask the windows of the storage rooms with red or orange covers or screens.

Radiation

Elastomer seals are to be stored protected from all sources of ionizing radiation likely to cause damage to the stored parts.

Oxygen and ozone

If possible elastomers should be stored in the original packaging or in airtight containers in order to protect them from circulating air.

Ozone is harmful to many sealing materials. Therefore no equipment producing ozone (i.e. mercury vapor lamps, high voltage electrical equipment, electric motors or other producers of electric sparks or electric discharges) shall be kept in the storage areas. Also combustion emissions and organic vapors should be avoided as they may produce ozone via photochemical processes.

Quality and storage

Deformation

If possible elastomer materials should be stored free from tension, compression or other deformation. Parts delivered in a tension-free condition should remain in their original packaging.

Contact with liquids and lubricants

Elastomer seals shall not come in contact with solvents, oils, greases or any other media at any time during storage, unless so packed by the manufacturer.

Contact with metal and non-metals

Direct contact with certain metals such as manganese, iron and particularly copper and its alloys, e.g. brass, are known to have damaging effects on some rubbers. Elastomer seals shall not be stored in contact with such metals.

Because of possible transfer of plasticizers or other ingredients, rubbers shall not be stored in contact with PVC. To avoid a mix-up different rubbers should preferably be stored separately from each other.

Cleaning

If necessary, cleaning should be carried out using soap and water (demineralized water to avoid lime stains) or denatured alcohol. However water shall not come into contact with fabric reinforced components, polyurethane rubbers or metal components without anti-corrosive protection. Disinfectants or other organic solvents as well as sharp-edged objects shall not be used. The cleaned parts should be dried at room temperature and shall not be placed near heat sources.

Shelf life and shelf life control

The shelf life of seals depends to a large extent on the polymer type. When stored under the above recommended conditions the below listed shelf life for the different materials can be considered.

NR, SBR	2 years
AU, TFE/P, Thermoplastics	4 years
CR, CSM, ECO, HNBR, IIR, NBR	6 years
ACM, AEM, EPDM	8 years
FKM, FMQ, FVMQ, VMQ	10 years
FFKM, Isolast®	18 years
PTFE	unlimited

Elastomer seals need to be checked after the above periods. If the seals are OK an extension of the shelf life is possible.

Elastomer parts and components with less than 1.5 mm thickness are more strongly affected by oxidation degradation even if stored under ideal conditions according to the above described. Therefore they need to be checked and tested more frequently than mentioned above.

Pre-assembled elastomer parts and seals

Generally it is not recommended to store elastomer seals in assembled condition. If it is necessary to do so it is recommended that the units should be checked at least every six months. The maximum shelf life period a rubber component is allowed to remain assembled within a stored unit is a total of the initial period stated above and the extension period. The inspection interval will depend on the design and geometry of the unit.

Contact your local marketing company for further information:

Europe	Telephone	Americas	Telephone
AUSTRIA - Vienna (ALBANIA, BOSNIA AND HERZEGOVINA, MACEDONIA, SERBIA AND MONTENEGRO, SLOVENIA)	+43 (0) 1 406 47 33	AMERICAS - REGIONAL	+1 260 749 9631
BELGIUM - Dion-Valmont (LUXEMBOURG)	+32 (0) 10 22 57 50	BRAZIL - São Paulo	+55 11 3372 4500
BULGARIA - Sofia (ROMANIA)	+359 (0)2 969 95 99	CANADA - Etobicoke, ON	+1 416 213 9444
CROATIA - Zagreb	+385 (0) 1 24 56 387	MEXICO - Mexico City	+52 55 57 19 50 05
CZECH REPUBLIC - Rakovnik (SLOVAKIA)	+420 313 529 111	USA, East - Conshohocken, PA	+1 610 828 3209
DENMARK - Hillerød	+45 48 22 80 80	USA, Great Lakes - Fort Wayne, IN	+1 260 482 4050
FINLAND - Vantaa (ESTONIA, LATVIA)	+358 (0) 207 12 13 50	USA, Midwest - Lombard, IL	+1 630 268 9915
FRANCE - Maisons-Laffitte	+33 (0) 1 30 86 56 00	USA, Mountain - Broomfield, CO	+1 303 469 1357
GERMANY - Stuttgart	+49 (0) 711 7864 0	USA, Northern California - Fresno, CA	+1 559 449 6070
GREECE	+41 (0) 21 631 41 11	USA, Northwest - Portland, OR	+1 503 595 6565
HUNGARY - Budaörs	+36 (0) 23 50 21 21	USA, South - N. Charleston, SC	+1 843 747 7656
ITALY - Livorno	+39 0586 22 6111	USA, Southwest - Houston, TX	+1 713 461 3495
THE NETHERLANDS - Barendrecht	+31 (0) 10 29 22 111	USA, West - Torrance, CA	+1 310 371 1025
NORWAY - Oslo	+47 22 64 60 80		
POLAND - Warsaw (LITHUANIA, UKRAINE, BELARUS)	+48 (0) 22 863 30 11	Asia Pacific	Telephone
RUSSIA - Moscow	+7 495 982 39 21	ASIA PACIFIC REGIONAL	+65 6 577 1778
SPAIN - Madrid (PORTUGAL)	+34 (0) 91 71057 30	CHINA - Hong Kong	+852 2366 9165
SWEDEN - Jönköping	+46 (0) 36 34 15 00	CHINA - Shanghai	+86 (0) 21 6145 1830
SWITZERLAND - Crissier	+41 (0) 21 631 41 11	INDIA - Bangalore	+91 (0) 80 2245 5157
TURKEY	+41 (0) 21 631 41 11	JAPAN - Tokyo	+81 (0) 3 5633 8008
UNITED KINGDOM - Solihull (EIRE)	+44 (0) 121 744 1221	KOREA - Anyang	+82 (0) 31 386 3283
AFRICA REGIONAL	+41 (0) 21 631 41 11	MALAYSIA - Kuala Lumpur	+60 (0) 3 9059 6388
MIDDLE EAST REGIONAL	+41 (0) 21 631 41 11	TAIWAN - Taichung	+886 4 2382 8886
		THAILAND - Bangkok	+66 (0) 2732-2861
		SINGAPORE	
		and all other countries in Asia	+65 6 577 1778

www.tss.trelleborg.com

