

TAKE-UP UNITS

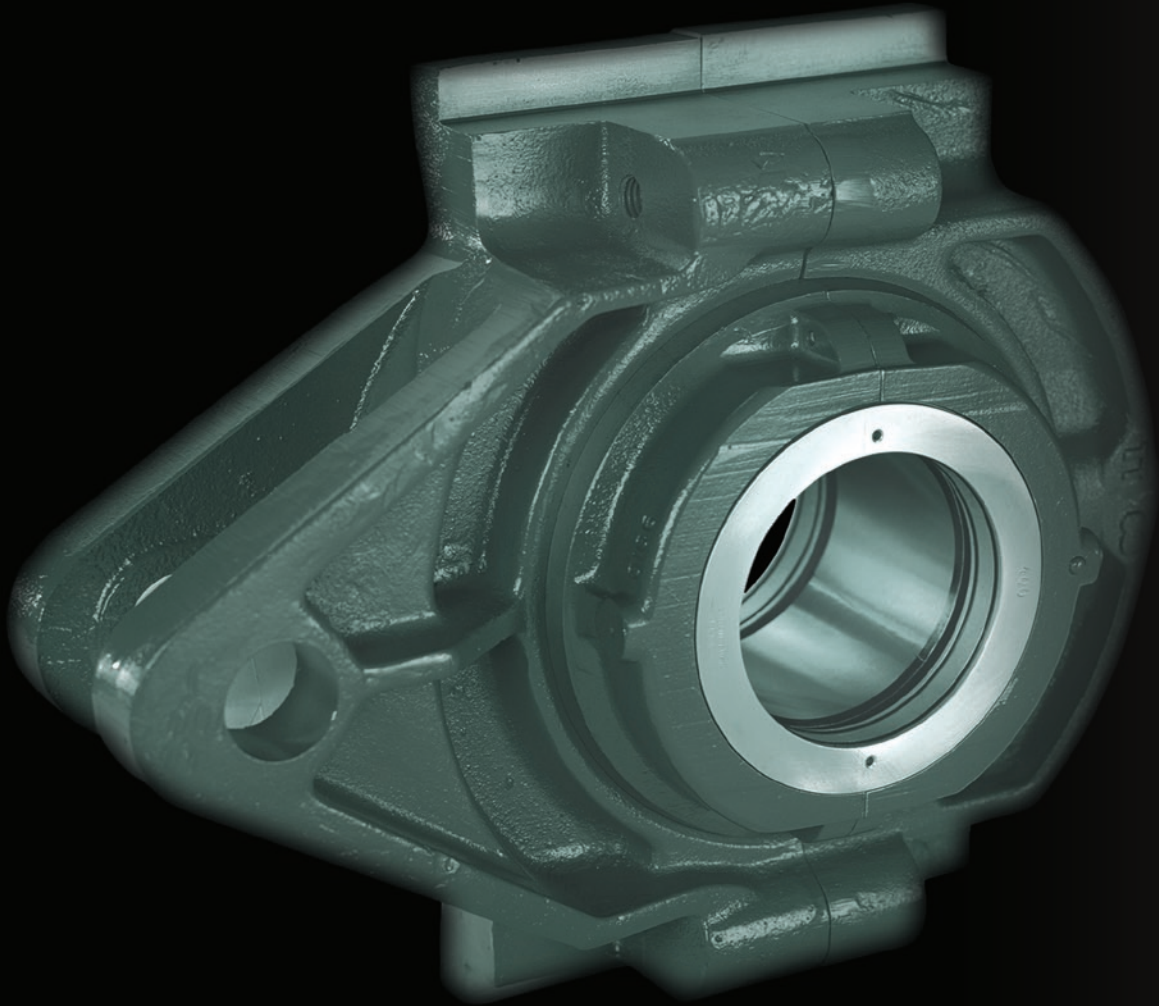

COOPER
SPLIT ROLLER BEARINGS

INTRODUCTION

Cooper take-up units are an efficient means of tensioning conveyor and elevator pulleys. Screw type, gravity type or spring-loaded tensioning systems all benefit from the unique features of Cooper bearings. The swivel cartridge takes up misalignment of the shaft, providing superior sealing and promoting longer bearing life.

The split-to-the-shaft technology allows in situ inspection and maintenance to be carried out easily and with minimum downtime. Cost efficiency, smooth operation of the machinery and customer satisfaction are therefore greatly enhanced.

Construction features

Each unit consists of a Cooper split roller bearing in a swivel cartridge, mounted in a cast iron sliding housing which enables the take-up to be mounted in a simple sub-frame. The single inner guide flange of the housing prevents it from moving outwards and can be used on unmachined, rolled steel sections of any size.

The design allows radial forces from belt tension to be transmitted through the housing and mounting frame centreline. This simplified frame also helps ensure that the pulley stays perpendicular to the belt during operation.

In conventional plummer block-type mountings, the load is offset from the bearing mounting point, making the framework more complex. The moment this creates tends to cause misalignment of pulley and framework, leading to problems in service.

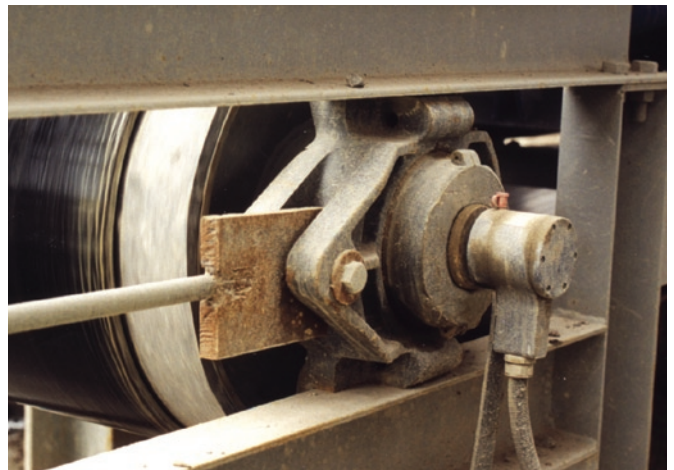

Typical take-up unit on a belt conveyor

Housing options

There are two configurations available. The push type (BCTP) is suitable for a typical screw take-up. The tension type (BCTT) has an 'eye extension' integral with the casting and is ideally suited to gravity, tension screw or spring-loaded take up configurations.

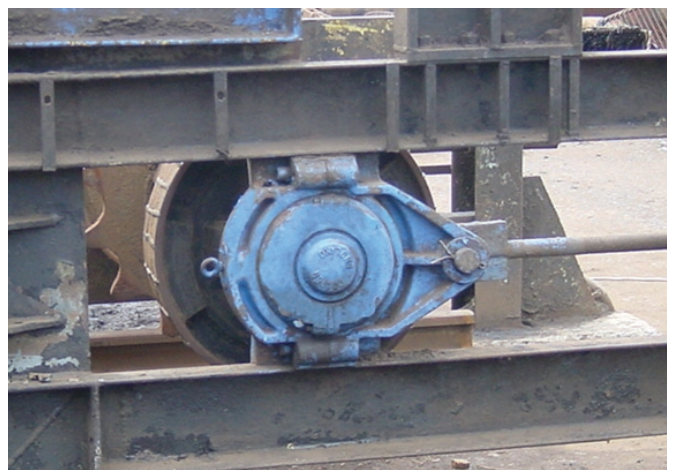

A tension take-up unit with blanking plate on a sugar mill conveyor

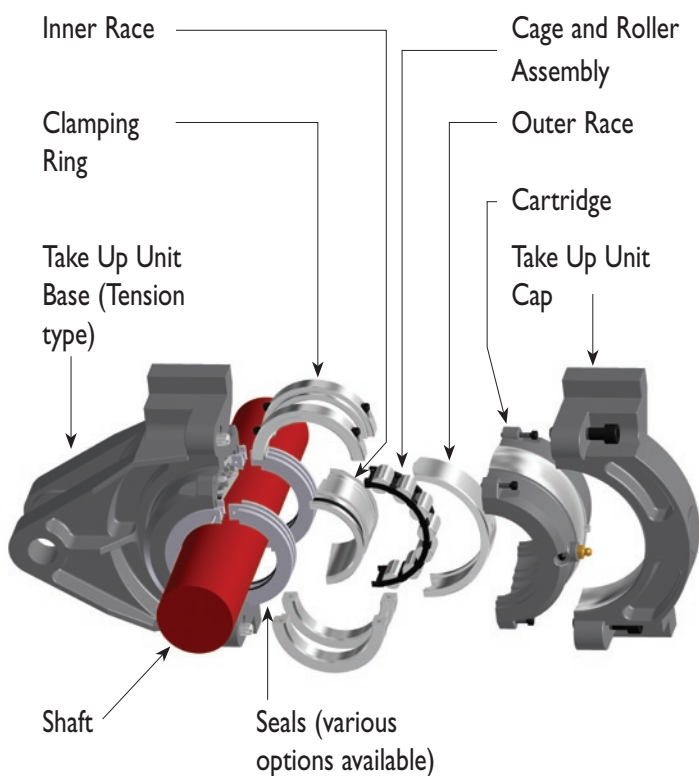

Handling misalignment

Misalignment, whether owing to manufacturing tolerances inherent in fabricated frameworks or due to deflections created by belt tension in operation, is a common phenomenon, even on new, conveyors. Self-aligning capability is therefore a necessity. Non-Cooper bearings may also have a self-aligning feature (e.g. double-row spherical) but they are compromised by the inefficiency of seals mounted in rigid housings.

Later in service, errors during installation and adjustment of take-up pulleys often leads to them being out of square with the belt. This is often accepted as inevitable, as manufacturers cannot prevent it without making major additions to their designs. For conventional designs, ingress of contaminants and loss of lubricant are in fact inevitable, and lead to premature bearing damage.

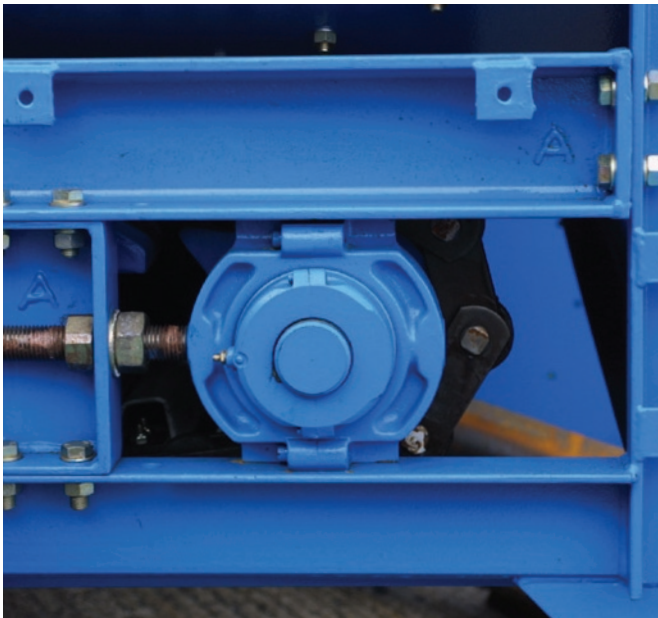

Cooper push type take-up unit on a newly built chain conveyor

Inspection and maintenance capability

The split feature of the Cooper bearing makes it easy to inspect in situ by simply removing the housing and cartridge halves. This permits preventative maintenance and corrective action at any time, avoiding any risk of the bearing failing prematurely, and thereby extending total bearing life.

If replacement is necessary, Cooper's split-to-the-shaft technology allows for a quick and easy changeover. There is no need to move adjacent machinery. Thanks to its simple construction and factory pre-set clearances, no highly skilled personnel or auxiliary heavy lifting equipment are needed. Downtime and work scope are thereby greatly reduced.

In push-type take-up units, depending on design, inspection and change-out can be conducted without releasing belt tension.



Typical Cooper tension type take-up unit in an aggressive quarry environment

Again, the Cooper self-aligning feature and superior bearing sealing provide an ideal solution. The swivel cartridge guarantees superior sealing, with the bearing, cartridge and seals remaining on the same axis as the shaft, regardless of the design or operational conditions. Bearing life is therefore unaffected.

Thrust loads

Misalignment of a pulley can induce large axial loads on the locating bearing. These loads are unpredictable in extent and direction under service conditions. In other products, including double-row sphericals, bearing life is adversely affected by the loads and may be much less than the calculated life (which assumes favourable conditions). With Cooper bearings, the axial and radial loads are carried independently and the calculated life is not influenced by the magnitude of the axial load..



Cooper tension take-up unit in a trapped location on a sugar mill conveyor

Shaft protection

Installation or replacement of a Cooper bearing, does not involve any axial movement, which is not the case with shrink-fit or adapter sleeve bearings. Cooper bearings are clamped in position radially. There is no shaft damage, no matter how often the unit is inspected, removed or replaced.

This is a long-term advantage, as shaft replacement is usually impossible. Shaft rework, by building up weld, is tedious, inefficient and often causes stresses that break the shaft. It also involves increased workload and huge amounts of downtime.

Effortless changeover for stand-by pulleys

Conventional designs require substantial effort, skills and downtime during installation, as well as complete pulley assemblies and a workshop environment. By contrast, a Cooper unit can easily be installed in situ by the users' own staff, thus saving greatly on associated costs.

Cooper can provide complete pulley assemblies pre-assembled and ready to use, with the bearings, grease and seals protected within the cartridge. Pulley exchange does not require realignment to the machine frame, as the outer housing does not need to be disturbed. Cartridge positioning and the realignment process, so time-consuming with non-Cooper products, take place automatically and quickly. The same is true when pulleys are removed for rework unrelated to the bearing. In addition, unlike in conventional systems, the bearings are never exposed and therefore last longer.



Take-up units (tension type)
35mm/1³/₁₆" to 155mm/6"



Take-up units (push type)
35mm/1³/₁₆" to 155mm/6"

Cost effectiveness

The design features of Cooper bearings, and the consequent advantages and benefits enjoyed by customers, make them a superior system and a first-choice solution.

Substantially lower running costs over very long lifetimes, easy and user-friendly maintenance, undisturbed, predictable operation of machinery and increased productivity are just some of the benefits. They reward everyone, from OE manufacturers, who can offer better and more flexible design, to end-users, who directly experience the improved performance of their equipment.

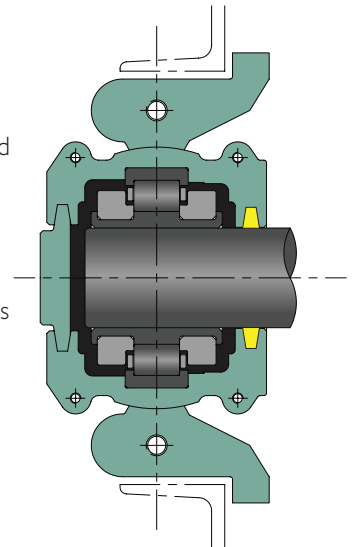

Section through take-up unit

COOPER BEARINGS GROUP

UK, Europe, South America, Asia, Australia and the Middle East

Cooper Roller Bearings Company Ltd.

Wisbech Road

Kings Lynn, Norfolk, PE30 5JX

United Kingdom

Tel: +44 (0) 1553 763447

Fax: +44 (0) 1553 761113

Email: CoopersalesUK@kaydon.com

USA, Canada, Mexico and Central America

The Cooper Split Roller Bearing Corp.

5365 Robin Hood Road, Suite B

Norfolk, VA 23513

USA.

Tel: +1 (1) 757 460 0925

Fax: +1 (1) 757 464 3067

Email: CoopersalesUS@kaydon.com

Germany

Cooper Geteilte Rollenlager GmbH.

Postfach 100 423

Oberbenrader Str. 407

47704 Krefeld GERMANY

Tel: +49 (0) 2151 713 016

Fax: +49 (0) 2151 713 010

Email: CoopersalesDE@kaydon.com

People's Republic of China

Cooper Bearings Group Beijing.

Room 909, Canway Building Tower I

No 66, Nanlishi Road, Xicheng District,

Beijing

PRC 100045

Tel: +86 (0) 10 68080803

+86 (0) 10 68080805

+86 (0) 10 68080806

Fax: +86 (0) 10 68080801

Email: CoopersalesCN@kaydon.com

Hong Kong

Cooper Roller Bearings (Hong Kong) Co. Ltd.

21st Floor Chinachem Tower

34-37 Connaught Road Central, Hong Kong

Tel: +852 6050 6633

Tel: +86 (0) 135 7010 7075

Email: CoopersalesHK@kaydon.com

Brazil

Cooper do Brasil Ltda.

Caixa Postal 66.105

CEP 05.314-970, Brasil

Tel: +55 (0) 11 3022 3706

Tel: +55 (0) 11 9156 2500

Email: CoopersalesBR@kaydon.com

India

Cooper Roller Bearings Company Ltd.

Wisbech Road

Kings Lynn, Norfolk, PE30 5JX

United Kingdom

Tel: +91 (0) 9820180089

Email: CoopersalesIN@kaydon.com